



RESEARCH ARTICLE

Design of an efficiency-enhanced Greinacher rectifier operating in the GSM 1800 band by using rat-race coupler for RF energy harvesting applications

Mahmut Ahmet Gozel¹  | Mesud Kahrیمان¹ | Omer Kasar² 

¹Department of Electronics and Communication Engineering, Suleyman Demirel University, Isparta, Turkey

²Department of Electrical and Electronics Engineering, Artvin Coruh University, Artvin, Turkey

Correspondence

Mahmut Ahmet Gozel, Department of Electronics and Communication Engineering, Suleyman Demirel University, 32260 Isparta, Turkey.
Email: mahmutgozel@sdu.edu.tr

Abstract

Radio frequency energy harvesting (RFEH) circuits can convert the power of communication signals from radio frequencies (RF) in the environment into direct current and voltage (DC power). In this study, the Greinacher full-wave rectifier circuit topology was combined with a 180° hybrid ring (rat-race) coupler which was a passive RF/microwave circuit. Thus, higher RF-DC conversion efficiency was obtained. First, using the Greinacher rectifier topology, RFEH circuit operating at the center frequency of 1850 MHz was designed. Then, at this frequency, designing of the rat-race coupler having 1000 MHz bandwidth was made. The S-parameter measurements and simulation data of the designed coupler circuit were compared. Finally, the high efficiency rectifier circuit where these two circuits were used together was designed. The proposed rectifier circuit was constructed on 70 × 70 × 1.6 mm³ FR4 substrate material with a permittivity of 4.3 ($\epsilon_r = 4.3$). The power conversion efficiency (PCE) of the rectifier circuit, which had 125 MHz bandwidth at the center frequency of 1850 MHz and was developed with rat-race coupler, was calculated as 71% at 4.7 dBm input power. In addition, with this study, at -15 dBm input power, which was a relatively low power level, 40% PCE value was obtained.

KEYWORDS

180° hybrid ring (rat-race) coupler, Greinacher full-wave rectifier, high efficiency rectifier topology

1 | INTRODUCTION

Today, the use of wireless devices has increased. Broadcasting from the stations with which these devices can connect is made at different frequencies and powers.¹ Therefore, there are radio frequency (RF) signals at different frequencies and power densities in the environment.^{2–4} These signals can be utilized by being collected with the help of a circuit. The process of obtaining the direct voltage and current (DC) by converting the power of the RF signals in the environment is called as radio frequency energy harvesting (RFEH). Thanks to the RFEH circuits, it is possible for the devices that require low power in the applications such as

sensor, RFID, and IoT to operate.^{5,6} This process is also a kind of wireless power transfer (WPT).⁷ Many RFID applications in the literature have been used in different areas such as electronic, communications, and biomedical.^{8,9} The general purpose in the RFEH application is to recover the low power consuming devices from the sources that require maintenance, such as batteries, and thus, to be able to provide continuous, cheap, and practical energy.^{10–13} In this way, it is possible to operate the devices by taking the energy from the environment or from a fixed WPT source.

RF Energy Harvesting circuits generally consist of antenna, impedance matching, rectifier and energy storage units. RF signals having low power density in the environment

are collected through an appropriate antenna. The received RF power is converted to DC power by a rectifier circuit so that a device or micro-system can be operated. This DC power is transferred to the load (device).⁹

In RFEH circuits, depending on the frequency of the RF signal to be harvested, many impedance matching techniques with narrow and broadband and at single or multiple frequencies are used.^{3,14–17} In this study, “single stub” and “radial stub” impedance matching techniques were used.

The most critical part of RFEH circuits is RF rectifier circuits. In RFEH and WPT circuits, many rectifier circuits have been used in the literature.^{18–20} In this study, for the RFEH application, Greinacher full-wave rectifier circuit was selected. This circuit, which was developed based on the conventional Greinacher full-wave rectifier circuit topology, has two different inputs. Using the 180° hybrid ring coupler circuit, a 180° phase difference can be created between these two RF power inputs. Considering this, it was aimed to enhance the Greinacher full-wave rectifier topology with 180° hybrid ring coupler, and thus to achieve high efficiency RF-DC conversion process.

2 | DESIGN OF GREINACHER FULL WAVE RECTIFIER

Rectification processes can be done using diodes, transistors or CMOS technology.²¹ In this study, HSMS-285C series Schottky diode was selected. The Spice parameters of the HSMS-285C diode are $R_s = 25 \Omega$ as serial resistance, $C_j = 0.18 \text{ pF}$ as junction capacitance, $I_s = 3 \times 10^{-6} \text{ A}$ as saturation current, $I_{BV} = 3 \times 10^{-4} \text{ A}$ as bias current. A good rectifier circuit needs to have low power consumption, increased power sensitivity and good power processing capacity. In the Greinacher circuit, fluctuation is zero under the open circuit conditions.²¹ However, it may also vary depending on the load resistance and the value of the capacitor that prevents the waviness. The circuit generally operates according to the operating principle of the Villard cell, which is an envelope detector stage. Peak detector cell provides prevention of the fluctuations that may occur in output and generates the output peak voltage.²² Figure 1A shows the conventional Greinacher full-wave rectifier circuit. On the other hand, Figure 1B shows the rectification part of the RFEH circuit proposed to be able to make rectification at high efficiency.

In this study, first of all the Greinacher full-wave rectifier circuit, which is available in the literature, was designed.^{5,23–25} The circuit shown in Figure 2A was designed with the ADS 2009 simulation program. An HSMS-285C integrated circuit contains two diodes. In the design, two HSMS-285C integrated circuits were used. Figure 2B shows the manufactured state of the Greinacher full-wave rectifier circuit, which was produced by FR4 substrate whose permittivity was 4.3 ($\epsilon_r = 4.3$) and loss tangent

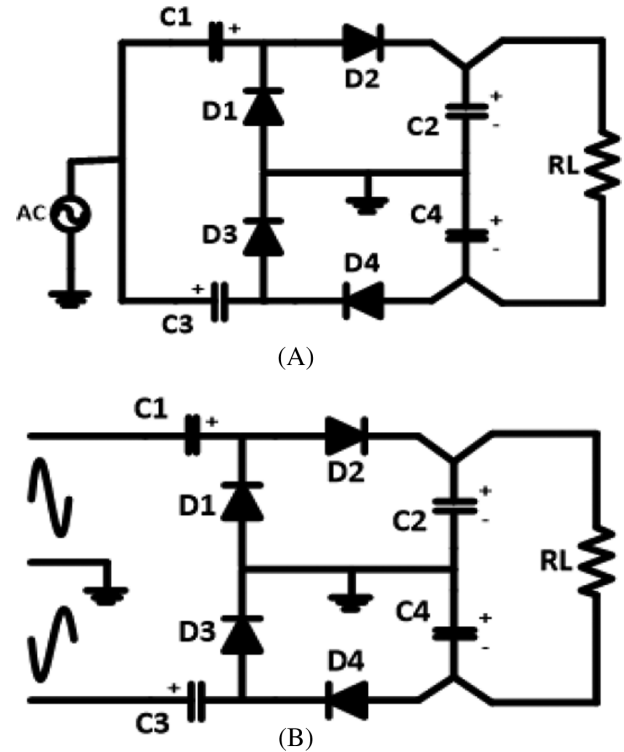

FIGURE 1 (A) Conventional Greinacher full wave rectifier, (B) proposed efficiency-enhanced Greinacher rectifier

was 0.025 ($\tan\delta = 0.025$). The thickness of the dielectric material is 1.6 mm and the underside of it is covered with copper. The value of the capacitors used in the circuit was selected as $C = 100 \text{ pF}$ and the load resistance value was selected as $R_L = 4.7 \text{ k}\Omega$.

In the circuit, shown in Figure 2, the length variables were set as follows; feed line width was 1.94 ($W_{P1} = 1.94 \text{ mm}$), single stub length was 7.65 mm ($L_1 = 7.65 \text{ mm}$), single stub width was 2.45 mm ($W_1 = 2.45 \text{ mm}$), width of the line where power was divided was 1.52 mm ($q = 1.52 \text{ mm}$), line length was 6.8 mm ($L_2 = 6.8 \text{ mm}$), width of the line to which the capacities were connected was 1.85 mm ($W_2 = 1.85 \text{ mm}$), width of the line to which the load was connected was 1.9 mm ($W_3 = 1.9 \text{ mm}$), width of the line to which the diode was connected as 0.8 mm ($W_4 = 0.8 \text{ mm}$), width of the rectifier circuit was 32 mm ($W_R = 32 \text{ mm}$), and its length was 36 mm ($L_R = 36 \text{ mm}$). In order to perform impedance matching between rectifier section on which diodes are located and port 1, the “single stub” lines and “radial stub” lines with 60° and 70° angles were used.

In RFEH circuits, the rectification efficiency is calculated as the ratio of DC power transmitted to the load to the RF power read at the input of the rectifier circuit. Because the RF signal is converted to the DC signal, it is called the power conversion efficiency (PCE). PCE is calculated as shown in Equation (1).²⁵

$$\eta_{\text{RF-DC}} = \frac{P_{\text{DC}}}{P_{\text{RF}}} = \frac{V_{\text{out}} \times I_{\text{out}}}{P_{\text{RF}}} = \frac{V_{\text{out}}^2}{P_{\text{RF}} \times R_{\text{Load}}} \quad (1)$$

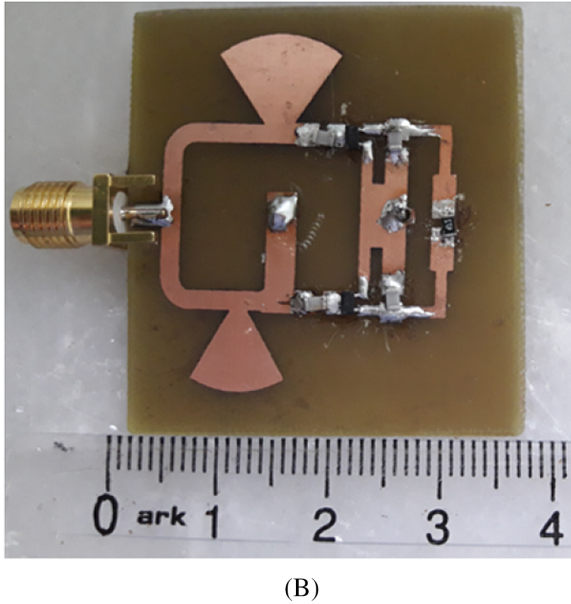
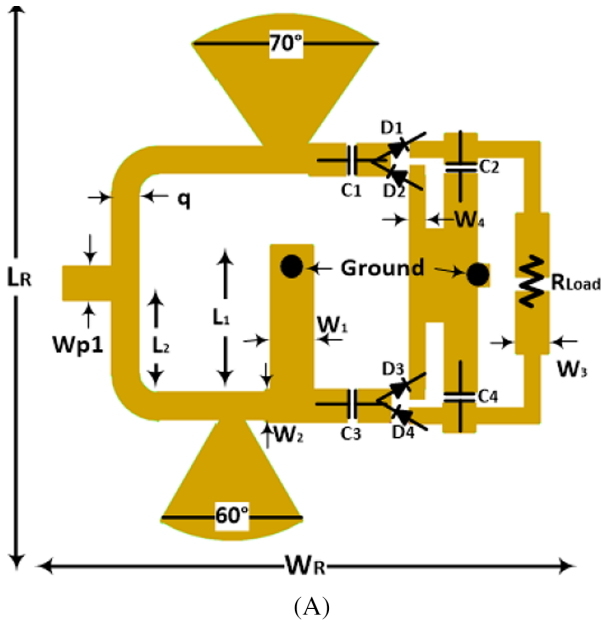

FIGURE 2 Schematic (A) and manufactured (B) view of conventional Greinacher full wave rectifier circuit

where, η_{RF-DC} is the efficiency of the rectifier circuit, P_{DC} is DC power transferred to the load, P_{RF} is the power coming to the input of the rectifier circuit, R_{Load} is load value at the output of the rectifier circuit, V_{out} is the voltage difference on the R_{Load} , and I_{out} is the current flowing through the load.

At 6 dBm input power and at the center frequency of 1850 MHz, the maximum PCE value of the circuit shown in Figure 2 was approximately 51%. The PCE value was calculated as 35% for -10 dBm input power and 14% for -20 dBm input power. The circuit carries out the rectification of the RF signal given from the input without 180° phase difference. In order to increase the rectifier efficiency,

it was suggested that the Greinacher rectifier circuit should be used with 180° hybrid coupler.

3 | DESIGN OF 180° HYBRID RING (RAT-RACE) COUPLER

The 180° hybrid ring, also known as rat-race, is a coupler type used in RF and microwave systems for the purpose of combining, dividing and isolation of power.²⁶ 180° hybrid ring coupler is a passive microwave circuit consisting of four ports. This coupler can divide the power by creating an equal and 180° phase difference depending on the port number where the input power is given. In addition, it can collect and take out RF signals from two different ports.

The 180° hybrid ring coupler basically divides the power of the RF signal given from the input port in two different ways. If 180° Hybrid ring coupler shown in Figure 3A is taken as reference, it can be said that the power of the signal applied to port 1 is divided into two halves in equal phase in Port 2 and Port 3. Logarithmic equivalent of this is calculated as -3 dB.²⁶ Port 4 is the insulated port and theoretically the power does not reach here. If the input signal is applied to port 4, the RF signal power is divided into two in Port 2 and port 3 with 180° phase difference. Port 1 is insulated and the power does not reach here. On the other hand, when input signals are applied to Port 2 and Port 3, the difference of inputs is in Port 4, and the total of them is in Port 1.²⁷ From this, it can be understood that an ideal -3 dB 180° hybrid ring coupler is symmetrical.

Figure 3A shows the dimension variables of the designed 180° hybrid ring coupler. In Figure 3B, the manufactured state of this coupler is presented. 180° Hybrid Ring Coupler was designed to be used in the rectifier circuit operating at the center frequency of 1850 MHz. Depending on the impedance, transmission line widths of the coupler were calculated by using the methods in the literature.^{28,29} In the design, some parameters are calculated mathematically; some of them have been selected as a parametrical over the simulation program. The calculated widths were as follows: width of the coupler was 62 mm ($W_H = 62$ mm), depending on the transmission line impedance, the line width of the ports was 3.2 mm ($W_p = 3.2$ mm), width of the ring strip was 1.6 mm ($W_L = 1.6$ mm), and the circle radius was 20 mm ($r = 20$ mm). The distance between Port 1, Port 2, and Port 3 was determined as quarter wavelength ($\lambda/4$) according to the center frequency (f_0) in which this circuit operates, and the distance between Port 2 and Port 4 was determined as the length of $3\lambda/4$.²⁷

The design of the proposed coupler circuit was modeled by CST and ADS 2009 simulation programs. The measurements of the S-parameters were carried out with the Rohde Schwarz FSH6 spectrum analyzer. The measurement and simulation results of the rat-race coupler are shown in Figure 4.

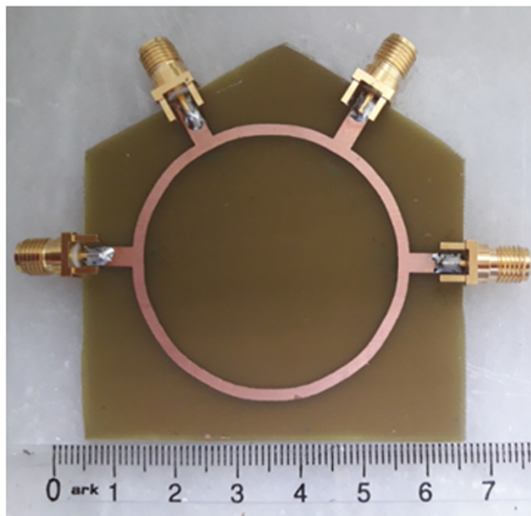
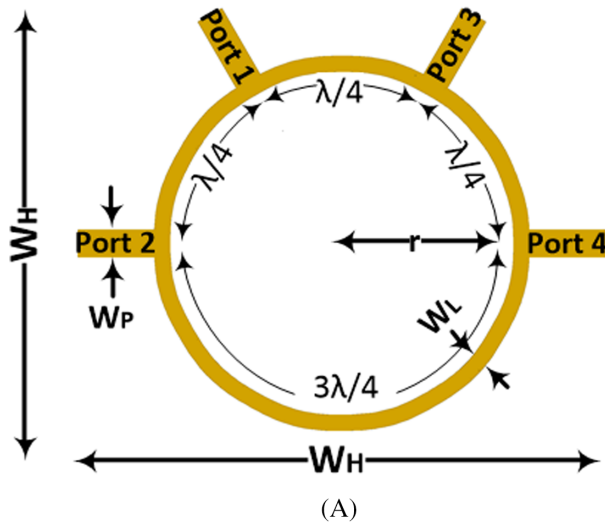

FIGURE 3 Schematic (A) and manufactured (B) view of 180° hybrid ring (rat-race) coupler circuit

In Figure 4, the measurement and simulation results of the S_{11} are shown at around -30 dB at the center frequency of 1850 MHz. It is understood that the transmission coefficients S_{12} (Figure 4A) and S_{13} (Figure 4B), which are around -3 dB at the same frequency, are very close to the half power level. Similarly, in Figure 4B, the insulation coefficient S_{14} gives result below -45 dB at the center frequency. From this, it is understood that the power is not transmitted to the 4th Port. The bandwidth of this coupler operating at the center frequency of 1850 MHz is around 1000 MHz.

4 | PROPOSED EFFICIENCY-ENHANCED RECTIFIER CIRCUIT

In recent years, 180° hybrid couplers and some other microwave passive circuits used for purposes such as dividing or combining power have been being used in RFEH circuits to increase bandwidth and efficiency.^{5,26,30–32} In this study,

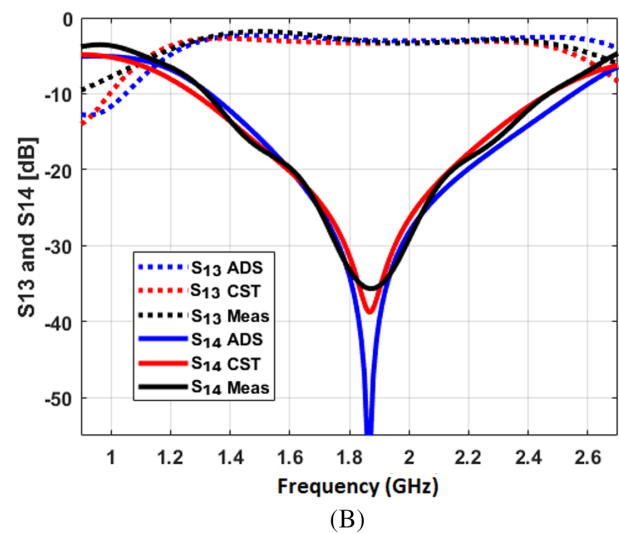
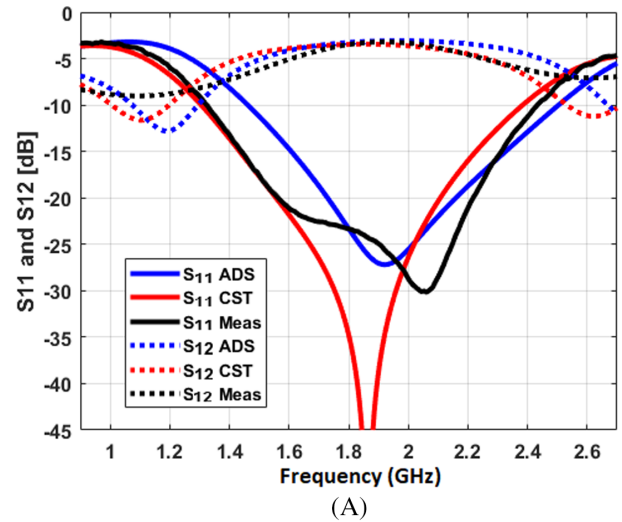

FIGURE 4 Reflection (A), isolation (B), and transmission (A,B) parameters of 180° hybrid ring (rat-race) coupler

180° hybrid ring (rat-race) coupler and Greinacher rectifier circuit were used together in order to increase the power conversion efficiency. The rat-race coupler was used to divide the RF signal given from the input into two equal powers having 180° phase difference. Thus, the Greinacher rectifier circuit was developed with rat-race coupler. The conventional Greinacher circuit was made compact by being placed inside the rat-race coupler structure.

Figure 5 shows the schematic view of the proposed rectifier circuit and the manufactured state of it. Here, unlike in Figures 2 and 3, $L_{W1} = 2.21$ mm was selected. Because, it is aimed to prevent the disturbing effects that occur due to the loading of rectifier to the coupler. Simulation studies of the proposed efficiency-enhanced rectifier circuit were performed with ADS 2009 software. The printed circuit was again made on FR4 substrate material. Table 1 shows the lengths of the variables of the circuits designed in this study.

Two different rectifier efficiencies can be calculated for the circuit given in Figure 5. Theoretically, if the RF signal is given from Port 1, the power of the RF signals halves in

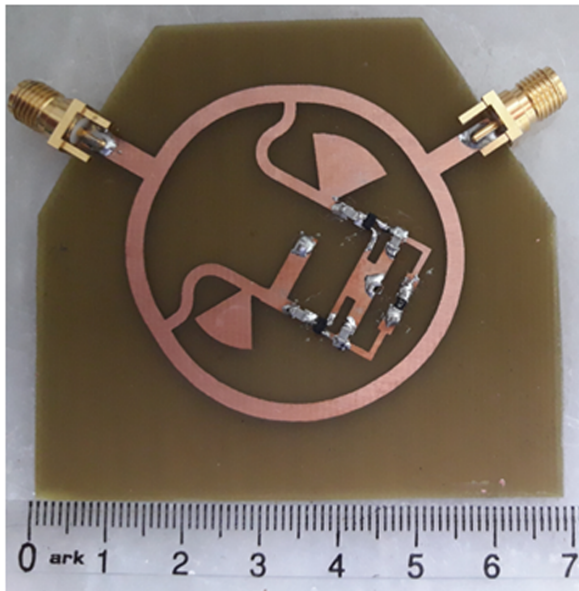
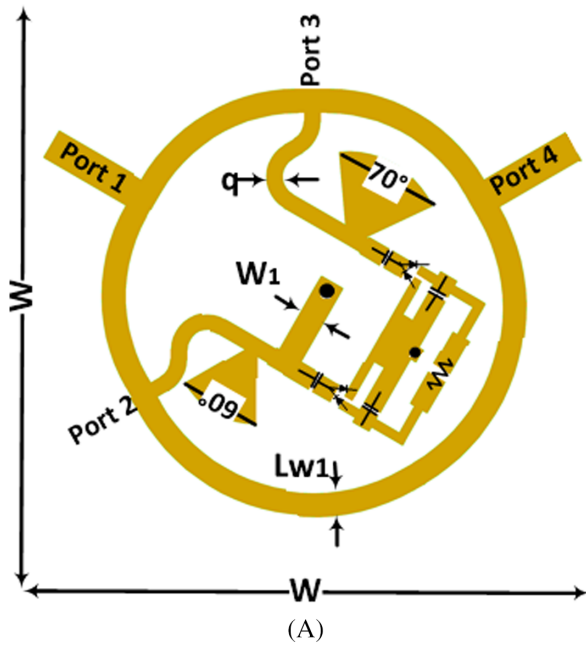

FIGURE 5 Schematic (A) and manufactured (B) view of proposed efficiency-enhanced rectifier circuit

Port 3 and Port 2 without phase difference. If the input signal is given from Port 4, the power of the RF signal halved in Port 2 and Port 3, but the 180° phase difference occurs. The simulation and measurement results of the S-parameters of the proposed hybrid structure are shown in Figure 6. In this figure, depending on the RF input signal being given from Port 1 and 4, return losses are seen. In both graphs, it is understood that the return loss at the center frequency of 1850 MHz is below the limit of -10 dB. When the RF input signal was given to the proposed rectifier circuit from Port 1, the bandwidth was calculated as 125 MHz at the center frequency of 1850 MHz. According to the measurement results, when the RF input signal is given from Port 4, the

TABLE 1 List of variables for the proposed design and their lengths

Variables	Rat-race (mm)	Conventional Greinacher (mm)	Proposed rectifier (mm)
W	-	-	70
W_H	62	-	-
W_L	1.6	-	-
W_{P1}	-	1.94	-
W_P	3.2	-	-
W_R	-	32	-
W_1	-	2.45	2.45
W_2	-	1.85	1.85
W_3	-	1.9	1.9
W_4	-	0.8	0.8
L_1	-	7.65	7.65
L_2	-	6.8	6.8
L_R	-	36	-
L_{W1}	-	-	2.21
q	-	1.52	1.52
r	19	-	20

bandwidth at 1800 MHz central frequency was calculated as 75 MHz.

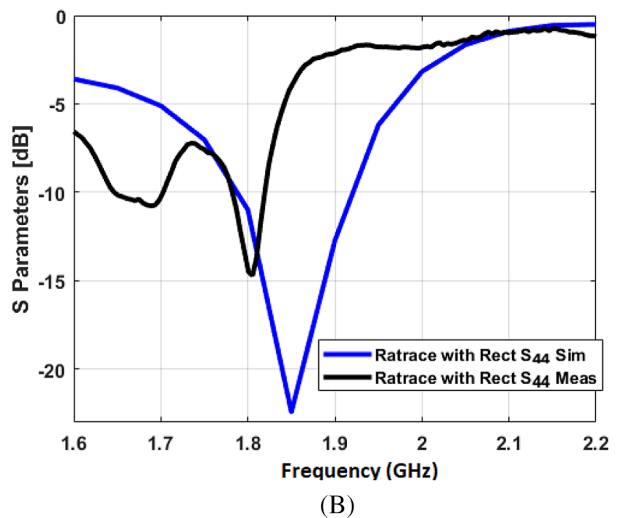
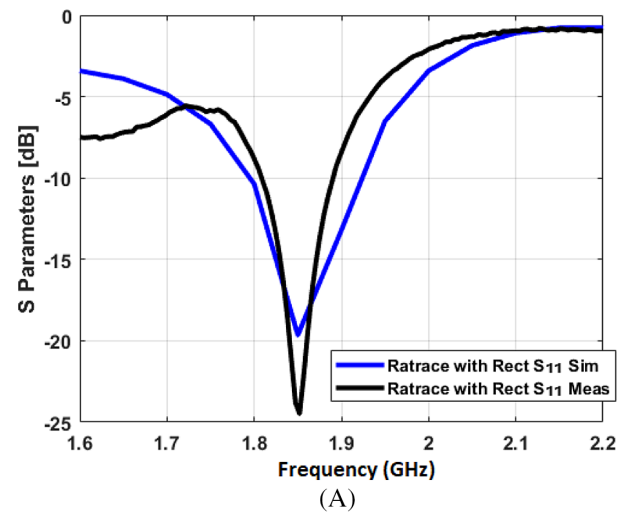

FIGURE 6 Reflection parameters for port 1 (A) and port 4 (B) of proposed efficiency-enhanced rectifier circuit

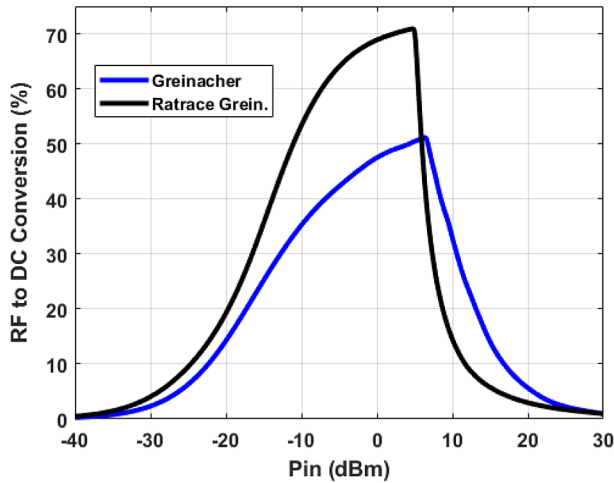

FIGURE 7 Comparison of the proposed rectification circuit with the classical Greinacher full wave rectification circuit in terms of power conversion efficiency

In Figure 7, the conversion efficiency from RF to DC of the rectifier circuit developed by rat-race coupler (hybrid ring coupler) is compared with the conventional Greinacher full-wave rectifier circuit. According to Figure 7, the proposed rectifier circuit has a higher PCE than the conventional design. It is understood that compared with the conventional rectifier circuit, the PCE value has increased between the input powers of -30 and 6 dBm by 20% in the proposed design.

Figure 8 shows the comparison of the output voltage of the hybrid-ring rectifier circuit proposed in the study with the conventional Greinacher rectifier circuit. According to the figure, it is understood that at the input power of 5 dBm, the output voltage of the proposed rectifier circuit has increased by about 1 Volt. It is seen that for all values of the input power, the proposed rectification circuit has high output voltage values relative to the conventional Greinacher rectifier circuit.

Considering that the power density of the RF signals in the environment is low in RFEH circuit, the effect of the

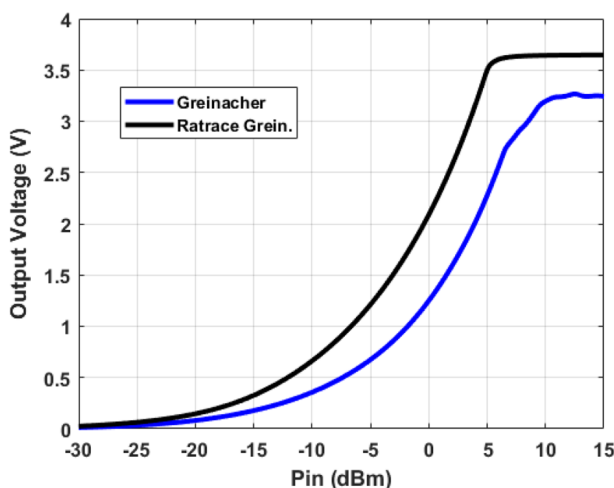

FIGURE 8 Comparison of the proposed rectification circuit with the classical Greinacher full wave rectification circuit in terms of output voltage

TABLE 2 Comparison of the proposed rectifier circuit design with previous studies

Ref.	Rectifier topology	Freq. [GHz]	Peak efficiency	Size [mm ²]
26	Villard voltage doubler	1.74-1.97 2.0-2.22 2.41-2.59	61.7% @ 9 dBm	70 × 65
5	Grein. full wave	2.45	~59% @ 0 dBm	40 × 40
33	Half-wave rectifier	1.8-1.87	52% @ -9 dBm	145 × 55
34	Half-wave rectifier	0.9, 1.8, 2.2	40% @ -10 dBm	84 × 35
This work	Grein. full wave	1.7-1.925	71% @ 4.7 dBm	70 × 70

proposed study on the low power energy harvesting is seen. In Table 2, the previous studies conducted to increase the efficiency in RFEH circuits are compared with the current study. In addition, the efficiency values for the different input powers of the proposed circuit can be listed as follows to compare peak efficiency of the other references: 20% @ -20 dBm, 40% @ -15 dBm, 54% @ -10 dBm, 65% @ -5 dBm, and 69% @ 0 dBm.

5 | CONCLUSION

In this study, a RF energy harvesting circuit was proposed by using the Greinacher circuit and the 180° hybrid ring coupler (Rat-race) circuit. The Greinacher full-wave rectifier circuit was redesigned with a 180° hybrid-ring coupler and it was used to increase the power conversion efficiency from RF to DC. In order to achieve this, it was benefited from the power division feature of the 180° hybrid ring coupler and the phase difference it created between the two ports. In terms of the analysis of the coupler scattering parameters, isolation (S_{14}), transmission (S_{12} , S_{13}), and reflection (S_{11}) values were obtained at approximately -35 , -3 , and -30 dB, respectively. The measurement values of the S_{11} and S_{44} (reflection) of the proposed high-efficiency rectifier circuit operate at a bandwidth of 125 and 75 MHz at around the center frequency of 1850 MHz.

It was observed that under this load ($R_{load} = 4.7$ k Ω) value, the proposed rectifier circuit increased its power conversion efficiency (PCE) by about 20%, especially in the range of -30 to 6 dBm input power. At all input power values, the output voltage of the proposed rectifier circuit was obtained higher. Whereas the maximum efficiency in the conventional Greinacher rectification circuit was calculated as 51% at 6.5 dBm, the maximum efficiency in the proposed study was calculated as 71% at 4.7 dBm input power.

ORCID

Mahmut Ahmet Gozel <https://orcid.org/0000-0002-0360-7188>

Omer Kasar <https://orcid.org/0000-0003-1859-5236>

REFERENCES

1. Song C, Huang Y, Zhou J, Zhang J, Yuan S, Carter P. A high-efficiency broadband rectenna for ambient wireless energy harvesting. *IEEE Trans Antennas Propag.* 2015;63:3486-3495.
2. C. Song, Y. Huang, J. Zhou, S. Yuan, Q. Xu, and P. Carter. A broadband efficient rectenna array for wireless energy harvesting. In: 2015 9th European Conference on Antennas and Propagation (EuCAP); 2015, pp. 1–5.
3. Piñuela M, Mitcheson PD, Lucyszyn S. Ambient RF energy harvesting in urban and semi-urban environments. *IEEE Trans Microw Theory Tech.* 2013;61:2715-2726.
4. Vyas RJ, Cook BB, Kawahara Y, Tentzeris MM. E-WEHP: a batteryless embedded sensor-platform wirelessly powered from ambient digital-TV signals. *IEEE Trans Microw Theory Tech.* 2013;61:2491-2505.
5. H. Zhang, Z. Zhong, Y.-X. Guo, and W. Wu. Differentially-fed charge pumping rectifier design with an enhanced efficiency for ambient RF energy harvesting. In: 2017 I.E. MTT-S International Microwave Symposium (IMS); 2017, pp. 613–616.
6. Guler U, Ghovanloo M. Power management in wireless power-sipping devices: a survey. *IEEE Circuits Syst Mag.* 2017;17:64-82.
7. Valenta CR, Durgin GD. Harvesting wireless power: survey of energy-harvester conversion efficiency in far-field, wireless power transfer systems. *IEEE Microw Mag.* 2014;15:108-120.
8. Kuhn V, Lahuec C, Seguin F, Person C. A multi-band stacked RF energy harvester with RF-to-DC efficiency up to 84%. *IEEE Trans Microw Theory Tech.* 2015;63:1768-1778.
9. Akyildiz IF, Su W, Sankarasubramaniam Y, Cayirci E. Wireless sensor networks: a survey. *Comput Netw.* 2002;38:393-422.
10. Mekid S, Qureshi A, Baroudi U. Energy harvesting from ambient radio frequency: is it worth it? *Arab J Sci Eng.* 2017;42:2673-2683.
11. Agbinya JI. *Wireless Power Transfer.* Vol 45. Aalborg, Denmark: River Publishers; 2015.
12. Tran L-G, Cha H-K, Park W-T. RF power harvesting: a review on designing methodologies and applications. *Micro Nano Syst Lett.* 2017;5:14.
13. R. B. Ofstein, V. Efe, A. B. Kurs, A. P. McCauley, A. M. Roy, E. Rollano, A. S. Rhoufiry, B. K. Sampson, M. P. Kesler, and M. J. MacDonald. Wireless power transfer. Google Patents WO2017084599A1. 2014.
14. H. Zhang and X. Zhu. A broadband high efficiency rectifier for ambient RF energy harvesting. In: 2014 I.E. MTT-S International Microwave Symposium (IMS); 2014, pp. 1–3.
15. Kuhn V, Seguin F, Lahuec C, Person C. Enhancing RF-to-DC conversion efficiency of wideband RF energy harvesters using multi-tone optimization technique. *Int J Microw Wirel Technol.* 2016;8:143-153.
16. Visser HJ, Vullers RJ. RF energy harvesting and transport for wireless sensor network applications: principles and requirements. *Proc IEEE.* 2013; 101:1410-1423.
17. H. P. Partal, M. A. Belen, S. Zorlu-Partal, and A. T. Ince. A Schottky rectifier design using EM simulation tools for RF energy harvesting applications. In: 2015 31st International Review of Progress in Applied Computational Electromagnetics (ACES); 2015, pp. 1–2.
18. Cha H-K, Park W-T, Je M. A CMOS rectifier with a cross-coupled latched comparator for wireless power transfer in biomedical applications. *IEEE Trans Circuits Syst II: Express Briefs.* 2012;59:409-413.
19. Lu Y, Ki W-H. A 13.56 MHz CMOS active rectifier with switched-offset and compensated biasing for biomedical wireless power transfer systems. *IEEE Trans Biomed Circuits Syst.* 2014;8:334-344.
20. Olgun U, Chen C-C, Volakis JL. Investigation of rectenna array configurations for enhanced RF power harvesting. *IEEE Antennas Wirel Propag Lett.* 2011;10:262-265.
21. Hemour S, Zhao Y, Lorenz CHP, et al. Towards low-power high-efficiency RF and microwave energy harvesting. *IEEE Trans Microw Theory Tech.* 2014;62:965-976.
22. Greinacher H. Das Ionometer und seine verwendung zur messung von radium-und rontgenstrahlen. *Phys Z.* 1914;15:410-415.
23. Belen MA. RF enerji hasatlama sistemleri için çift bandli greinacher doğrultucu devre tasarımı. *Mühendis Bilim Tasar Derg.* 2018;6:348-353.
24. Park J, Kim Y, Yoon YJ, So J, Shin J. Rectifier design using distributed Greinacher voltage multiplier for high frequency wireless power transmission. *J Electromagn Eng Sci.* 2014;14:25-30.
25. Zeng M, Li Z, Andrenko AS, Liu X, Tan HZ. Differential voltage octuple rectifiers for wireless energy harvesting. *Microw Opt Technol Lett.* 2017;59: 1574-1578.
26. Li Z, Zeng M, Tan HZ. A multi-band rectifier with modified hybrid junction for RF energy harvesting. *Microw Opt Technol Lett.* 2018;60:817-821.
27. Pozar DM. *Microwave Engineering.* New York, NY: John Wiley & Sons; 2009.
28. Constantine AB. *Antenna Theory: Analysis and Design.* New York, NY: John Wiley & Sons; 2005.
29. Pozar DM. Microstrip antennas. *Proc IEEE.* 1992;80:79-91.
30. Wei M-D, Chang Y-T, Wang D, Tseng C-H, Negra R. Balanced RF rectifier for energy recovery with minimized input impedance variation. *IEEE Trans Microw Theory Tech.* 2017;65:1598-1604.
31. Xiao YY, Du Z-X, Zhang XY. High-efficiency rectifier with wide input power range based on power recycling. *IEEE Trans Circuits Syst II: Express Briefs.* 2018;65:744-748.
32. Li J-L, Wang B-Z. Novel design of Wilkinson power dividers with arbitrary power division ratios. *IEEE Trans Ind Electron.* 2011;58:2541-2546.
33. Sun H, Guo Y-X, He M, Zhong Z. A dual-band rectenna using broadband Yagi antenna array for ambient RF power harvesting. *IEEE Antennas Wirel Propag Lett.* 2013;12:918-921.
34. Khemar A, Kacha A, Takhedmit H, Abib G. Design and experiments of a 3G-band Rectenna for radio frequency energy harvesting. *Rev Roum Sci Tech-Ser Electrotech Energet.* 2017;62:82-86.

AUTHOR BIOGRAPHIES



MAHMUT AHMET GOZEL was born in Istanbul in 1987. He obtained his B.E. degree in Electronics and Communication Engineering from Suleyman Demirel University, Turkey, in 2011, and M.Sc. degree from the same university, in 2015. He is currently a Research Assistant in Department of Electronics and Communication Engineering and pursuing his Ph.D. degree at the same department. His research area is about designing RF rectifier topologies and harvesting RF Energy for low power devices. Also, He interest in RF and microwave passive circuits design.



MESUD KAHRIMAN was born in Stuttgart, Germany, on April 14, 1976. He received the B.Sc. and M.Sc. degrees from Sakarya University in 1997 and 2001, respectively, and the Ph.D. degree in Electrical and Electronic Engineering from Sakarya University, Turkey in 2004. He is currently a lecturer in the Department of Electronics and Communication Engineering in the Faculty of Engineering, Suleyman Demirel University, Turkey. His research interest at present includes RF Energy Harvesting, RFID antennas, Microcontrollers, Measurement and Instrumentation.



OMER KASAR received his B.E. degree in Electronics and Communication Engineering in Suleyman Demirel University, Isparta, Turkey in 2011; and then received M.Sc. degree in 2015 and he is pursuing his Ph.D. degree in the same university. He is currently a

Research Assistant in Department of Electrical and Electronics Engineering in Artvin Coruh University, Turkey. His research interests include RF Energy Harvesting for wireless applications, Broadband impedance matching, Microwave passive circuit design and Frequency selective surfaces.

How to cite this article: Gozel MA, Kahrman M, Kasar O. Design of an efficiency-enhanced Greinacher rectifier operating in the GSM 1800 band by using rat-race coupler for RF energy harvesting applications. *Int J RF Microw Comput Aided Eng.* 2019; 29:e21621. <https://doi.org/10.1002/mmce.21621>