

# We are IntechOpen, the world's leading publisher of Open Access books Built by scientists, for scientists

5,500

Open access books available

136,000

International authors and editors

170M

Downloads

Our authors are among the

154

Countries delivered to

TOP 1%

most cited scientists

12.2%

Contributors from top 500 universities



WEB OF SCIENCE™

Selection of our books indexed in the Book Citation Index  
in Web of Science™ Core Collection (BKCI)

Interested in publishing with us?  
Contact [book.department@intechopen.com](mailto:book.department@intechopen.com)

Numbers displayed above are based on latest data collected.  
For more information visit [www.intechopen.com](http://www.intechopen.com)



# Economic Applications for LED Lights in Industrial Sectors

*Muhammad M.A.S. Mahmoud*

## Abstract

After the Introduction, which discuss the main advantages and disadvantage of LED from Economics angle, the entire Chapter is presented in three sections. The first section discusses the economic benefits of replacing different types and rating of outdoor HID lights, typically installed in an industrial plant, with LED lighting. The section determines important economic indicators to evaluate direct and indirect benefits that can be achieved from using LED lights. In second section an efficient, safe and cost effective design to automate LED lighting system used for long roads with low-traffic is provided. The section provides smart control using image recognition for cost saving of road lighting operation and gives economic analysis for this lighting system. In third section, design of intelligent daylight utilization to achieve efficient indoor lighting intensity control for LED lights that are used in industrial building is provided. Comprehensive evaluation of the lighting system economics is discussed.

**Keywords:** LED economics, LED verses HID, lighting economic norm, control technology with LED, LED in industrial application smart road lighting

## 1. Introduction

Light emitting diodes are rapidly developing in light output, color rendering, efficiency, and reliability. Achieving good level of maintenance-free in harsh environment, while keeping product competitive, is the largest challenge which only few manufacturers manage to achieve. The latest high quality LED technologies are already exceeding all other available technologies by all technical parameters. According to its numerous advantages, even higher initial cost quickly pays for itself due to vastly reduced cost of electricity and maintenance. But to fully benefit from the outstanding advantages it is important to educate and recognize the difference between low quality and latest state of the art LED technologies, since low quality LED alternatives have quickly spread all over the world [1, 2].

### 1.1 General advantages of high quality LED lights

#### 1.1.1 Less energy consumption

LED lights use 40–80% less electricity and have at least 5 times the life expectancy than regular High Pressure Sodium (HPS) fixtures. LED lamps are 7 times more energy efficient than incandescent and twice as efficient as fluorescent lamps.

### 1.1.2 Higher efficiency and low light pollution due to directional light

LED lights with a lower lumen output can replace conventional lamps with a higher output. For example, a 30 W LED street light can often replace an 80 W High Pressure Sodium lamp. The reason for this is directionality. LED street lamps are very directional and the light output is much more than other street lamps. Also there is little or no hot spot under the LED lamp. The light emitted from the LED lamp is directed downwards, spread throughout the entire area it covers. This means that a lower amount of light is needed to properly illuminate the area. This also dramatically reduces glare and light pollution which affects the mood of human beings, navigation in birds and insects, mating behavior in animals and flowering in plants.

### 1.1.3 Long life: up to 100.000 hours

LED lights last much longer than conventional lamps (4 to 8 times longer). This result in less expense in replacing the lights themselves but also the labor to replace the lamp is needed less often. This provides a great cost savings by itself.

Also the loss of brightness or lumen depreciation is slower over the life of an LED lamp than that of sodium or other lamp. So not only does the LED have a longer life span than the conventional lamp, but it stays brighter longer than other lamps. The long life span reduces maintenance expenses and makes these bulbs particularly suitable for difficult to reach locations and for streetlights where maintenance costs can be significant.

Lifetime and Lumen maintenance compression between LED and HID lights is illustrated in **Figure 1**. The comparison shows that relamping of HID fixture is required to be done 5 times to achieved one base life time of LED, considering the relamping is required when the Lumen reduces to 70% of initial lamp Lumen [1].

### 1.1.4 Great operating characteristics

LED operates at efficiently at low and high temperatures, and unaffected by on/off cycling. This makes them safer and efficient in special indoor applications such

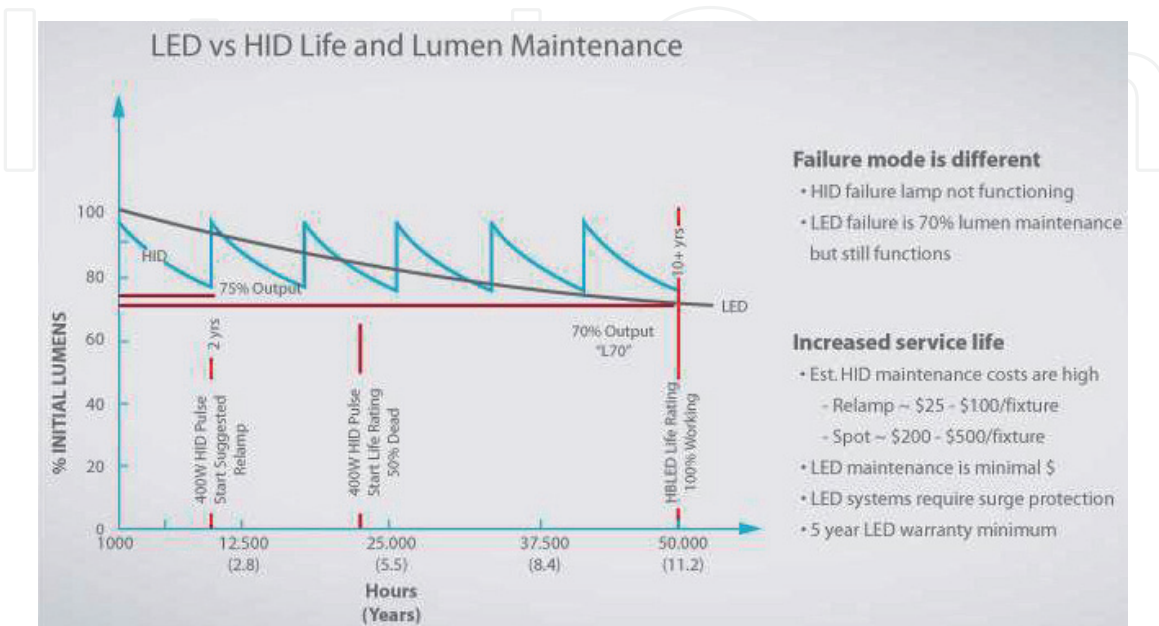

**Figure 1.** Lifetime and lumen maintenance compression between LED and HID.

as refrigerator lights, cold room lights, offices, industrial plants and better for applications requiring frequent switching on and off lights. These bulbs are shocks and vibrations resistant making them the best choice for places like offshore platforms, oil refineries, steel factors, skids and similar applications.

#### *1.1.5 Easily controllable*

The light is easily controllable with intelligent systems. The light can be turned on and off instantly and can be dimmed for added energy savings at dawn, dusk, and also during hours of low traffic. Switching on–off and dimming does not affect the life-time of the luminaire as in the case of fluorescent lights.

#### *1.1.6 Reducing carbon footprint*

The carbon footprint of LED street lights is smaller than other lights due to lower energy usage. Moreover, LEDs last 4 to 8 times longer than any other bulbs, further reducing the carbon footprint of manufacture over the life time. From another angle, wide range application of LED in a country may give better chance to sale there international quota in CO<sub>2</sub> emission to other countries.

#### *1.1.7 Dark-sky friendly*

Because of the directional light, light is carefully distributed exactly where it is meant to go and therefore there is no or little light which is wasted by illuminating the night sky or very low background light contribution. This is a considerable plus especially if the local community has a Dark-sky Initiative.

#### *1.1.8 Natural light specter: Color rendering index*

It is worth to mention here that for example LED street lamps with color temperature 3.500–4.200 K are rendering more natural light than the yellow of sodium lamps or green of fluorescent streetlights. Also no UV or IR radiation is emitted from the LED street lamps. Color rendering index (CRI) is high (80–90) and displays natural colors of illuminated objects. This reflect actual color of the objects.

#### *1.1.9 Free of harmful substances and lower environmental impact*

LED luminaires contain no harmful substances, like mercury, lead or other hazardous chemical and gasses. Spent LED lamps can be thrown away without any special handling or disposal requirement, since they are recyclable and environmentally friendly. Other lighting bulbs often have hazardous materials such as lead and mercury which require special handling and waste management procedures which have both economic and environmental costs.

### **1.2 International and National Directives**

European Commission issued the Regulations EC No. 245/2009 for tertiary lighting products on 18 March 2009. On the basis of these Regulations, about 1 billion lighting products have to be replaced by LED type by the year 2015 only in the area of the EU, which translates to 100 million street lamps for street lighting and industry. The remaining 900 million refer to neon lamps.

Similarly, the Energy Information and Security Act of 2007 began the process of restricting the sale of inefficient lamps in the US. By 2012, with a few exceptions, the result of the legislation will be that inefficient incandescent lamps cannot be sold [1].

## **2. Economic benefits of replacing different types and rating of outdoor HID lights by LED**

### **2.1 Survey and problem definition**

High-intensity discharge lamps (HID lamps) are a type of electrical gas-discharge lamp which produces light by means of an electric arc between tungsten electrodes housed inside a translucent or transparent fused quartz or fused alumina arc tube. This tube is filled with noble gas and often also contains suitable metal or metal salts. The noble gas enables the arc's initial strike. Once the arc is started, it heats and evaporates the metallic admixture. Its presence in the arc plasma greatly increases the intensity of visible light produced by the arc for a given power input, as the metals have many emission spectral lines in the visible part of the spectrum.

Many lighting application use HID bulbs for the main lighting systems, although some applications are now moving from HID bulbs to LED because of the LED advantages [2].

By about 2010 LED technology came to dominate the outdoor lighting industry; earlier LEDs were not bright enough for outdoor lighting. A study completed in 2014 concluded that color temperature and accuracy of LED lights was easily recognized by consumers, with preference towards LEDs at natural color temperatures [3]. LEDs are now able to match the brightness and warmer color temperature that consumers desire from their outdoor lighting system.

By comparing the power characteristics and lighting characteristics for LED versus traditional lighting, it can be concluded that using LED lighting to replace the traditional lighting devices are possible and recommended. However, still protection circuits such as current, voltage and temperature are still needed to be revised to increase the reliability. In order to make such mission become truth, the first important thing should be done is to lower the unit cost and secondary to have a proper and reliable power circuit with less loading and less electrical faults probabilities. Also suitable optics is needed to control the light pattern from the LEDs including focus, diffusion, reflection, and light amplification [4, 5].

For indoor Lighting, seven criteria are proposed to assess the technical and economic characteristics of LED luminaires and ensure their compliance with European Norms regarding office lighting. The proposed decision support system can be applied to any type of luminaire and can be used by professionals who want to evaluate different luminaire suppliers and determine the optimal luminaire tender for the lighting of any indoor space [6].

Other researches concentrated in Road lighting to compares mainly the life cycle costs (LCCs) of two typical alternatives in current road lighting: the HPS and LED luminaires. These studies have considered only the road lighting design criteria, but the esthetics and visual attractiveness are excluded from the comparison. The comparison and the results have considered only the direct energy operating cost [7]. Also an Economic cost analysis comparison between LED and HPS flood lights for an outdoor design, but using solar PV as a power supply, has been carried as a part of renewable energy design [8].

Feasibility study of LED lamp in replacing the conventional fluorescent lamp was conducted. Analysis and comparison have been carried out on the two lighting



systems in terms of electrical and photometrical performance. The study did not cover any HID outdoor lighting [9].

Comprehensive techno-economic analyses that considered the Company and National economic benefits that can be achieved from the high service life of the LED light fittings (up to 100,000 Hours) and its low power consumption compared with HPS was carried out. However, this analysis is limited only for 400 W HPS lighting case.

For the above survey, it can be found that several efforts carried out economic analysis of replacement different light fittings with LED. But, none of these works has considered the economics for replacement the HID lamps by LED lamps in industrial plants. Moreover, none of these researches have presented any type of economic index to support such type of lighting projects, except [10], which limited the research the replacement of only HPS type used in access road of a gas production company.

Based on the above survey, the first goal of this chapter is to discuss the economic benefits of replacing outdoor different type of HID lights with different rating installed in an oil and gas plant, as typical “Case-Study” for industrial plant, with suitable equivalent number of LED lighting fittings, to provide even better lighting effect level, without changing the lighting poles. The second goal is to determine the global saving norm based on two main aspects. “Company Benefits”, in which the Company can gain it directly, and “National Benefits” that can be achieved by creating better gas sales opportunity for the county and by the reduction of the CO<sub>2</sub> emission and hence the pollution.

## **2.2 Case-study: techno-economic model analysis for replacement of HID lamps with LED lamp in oil and gas plant**

In this section, firstly, comprehensive economic study is introduced to replace 241 pieces of 150 W Metal Halide, 103 pieces of 400 W HPS lighting, 20 pieces of 1000 W MH lighting and 162 pieces of 70 W Bollard lighting by equivalent number of LED lighting fittings. Next, economic discussion is to carried out to provide four important economic indicators. Finally, summary, conclusion and recommendation are given.

### *2.2.1 Economic study methodology*

The methodology in this economic study is carried out to estimate the financial benefits of replacement of outdoor HID (High intensity discharge) lights in an oil and gas plant by the equivalent LED (Light Emitting Diodes) lighting fixture. The Study has considered the following factors:

#### A. Company (Direct) Benefits:

- a. The initial cost of the replacement the lighting fixtures.
- b. The energy saving.
- c. The maintenance cost.

#### B. National (Indirect) Benefits:

- d. Natural Gas Sales opportunity
- e. Pollution Cost

In Company Benefits, calculation for “Luminaire Cost”, “Power Consumption” and “Maintenance Cost” are given based on offers and prices collected on 2015–2016 from different bidders, contractors and suppliers to find the lowest prices.

In National Benefits, two benefits are considered. First benefit is the gas sales opportunity that will be gained from the reduction of the power consumption in case LED light is used. Natural gas valued using the wholesale price of \$4.618/MMBtu based on US Energy Information Administration Henry Hub/NYMEX futures prices; Equivalent energy rate of 5.6 ¢/kWhr is used to value the energy produced over 10 years, assuming 1% annual escalation factor and Euro to USD exchange rate of 1.2 [10, 11] Accordingly,

$$\text{Annual Natural Gas Sale Opportunity} = 1.2 \times 0.056 \times \Delta \text{kWhr} \quad (1)$$

Where  $\Delta$  kWhr is the reduction in the power consumption.

However, the second benefit is the cost saving due to the reduction of the CO<sub>2</sub> emission, and hence less pollution. Carbon credits based on current market is typically 6 euro/ton. Where, CO<sub>2</sub> emission is considered to be 0.83 kg/kWh. Assuming Euro to USD exchange rate of 1.2, the annual saving in pollution reduction can be calculated as following [10, 11]:

$$\text{Annual Saving in Pollution} = \frac{0.83 \times \Delta \text{kWhr} \times 6 \times 1.2}{1000} \$ \quad (2)$$

The economic study is categorized based on HID lamp type that is needed to be replaced in the plant under the study. Typical study is summarized in the following **Table 1** for 150 W Metal Halide luminaire replaced by 65 W GREE LED luminaire. Where.

$$\text{Company Saving N} = \frac{\text{Annual Company Net Saving}}{\text{Total kW for the Replaced HID Lighting}} \quad (3)$$

$$\text{Total Saving N} = \frac{\text{Total Net Average Annual Saving}}{\text{Total kW for the Replaced HID Lighting}} \quad (4)$$

Similar to the typical economic study that is carried out for 150 W Metal Halide lighting, economic study is done for the remaining types of lighting; 103 pieces of 400 W HPS lighting, 20 pieces of 1000 W MH lighting and 162 pieces of 70 W Bollard lighting. Summary Tables (**Tables 2–5**) are provided hereinafter to show the Total Benefit and the Economic Analysis for these luminaire types.

Base on the above techno-economic, following **Table 5** is developed to summarize the main project economics indicators that can be used as good guide line for future similar projects that consider the replacement of HID lighting by LED Lighting.

### 2.2.2 Economic discussion

Based on the Saving Norm calculated for individual luminaire type in the above from **Tables 1–4** the Global Saving Norm can be calculated based on the following Eq.:

$$\text{Global Saving Norm} = \frac{1}{n} \left( \sum_1^n \text{Norm}_n \right) \quad (5)$$

Where “n” is the number of replaced lighting types in the study.

Using Eq. (7), the calculated Global Company Saving Norm is (355.19\$/kW).

<b>Company Benefits</b>				
<b>I. LUMINAIRE PRICE ANALYSIS</b>				
S/N	Description	150 W MH Metal Halide [12]	65 W CREE LED [13]	Remarks
1	Initial Fixture cost	\$227.52	\$449.59	
2	Total quantity	241	241	
3	Total quantity Cost	0	108351.4986	
4	Cost/lamp manpower, crane, dumping etc. ...	108.9918256	108.9918256	This estimate taking into consideration replacement cost, man power, vehicle, manpower to divert/block traffic, cost of loading/unloading & installation
a	Therefore initial investment for LED	0	\$134,618.53	Additional investment for using LED luminaire.
<b>II. POWER CONSUMPTION ANALYSIS</b>				
S/N	Description	150 W MH Metal Halide [12]	65 W CREE LED [13]	Remarks
1	Wattage per fixture	150	72	System Wattage includes losses
2	No of fixtures in the lighting circuit	241	241	
3	Total power consumed (kW)	36.15	17.352	
4	Hence total Power consumed per year (kWhr)	145142.25	69668.28	Average daily operating time is considered 11 Hours
5	Cost per kWhr	0.026948229	0.026948229	As agreed with Utility
6	Annual cost	3911.326574	1877.436755	
7	Service Life Range	16,000–20,000	60,000–100,000	
8	Average Service life (Hrs)	18,000	80,000	
b	Therefore the saving in 10 Years	\$20,338.90		
S/N	Description	150 W MH Metal Halide [12]	65 W CREE LED [13]	Remarks
	Service Life Range	16,000–20,000	60,000–100,000	
1	Average Service life (Hrs)	18,000	80,000	
2	Number of Lamps change cycle in 10 Year	2.230555556	0	LEDs have no downtime against MH lamps which fail arbitrarily
3	Total No. of Lamps	538	0	
4	Cost/lamp manpower, crane, dumping etc	108.992	0	The estimate take into consideration new lamp cost, man power, vehicle, manpower to divert/block traffic, cost of loading/unloading & installation.



S/N	Description	150 W MH Metal Halide [12]	65 W CREE LED [13]	Remarks
c	Therefore savings in lamp maintenance in 10 Years	\$181043.6		

**IV. MAINTENANCE COST SAVING ANALYSIS- IGNITORS / BALLASTS / CAPACITORS**

S/N	Description	150 W MH Metal Halide [12]	65 W CREE LED [13]	Remarks
1	Rated life (Hrs)	15,000	N/A	
2	Life in 10 years	2.676666667	N/A	
3	Total No. of Ballasts	241	N/A	
4	Thus component to be replaced in 10 Years	645	N/A	
5	Cost/lamp manpower, crane, dumping etc. ...	81.74386921	N/A	This estimate takes into consideration new ballast cost, man power, vehicle, manpower to divert/block traffic, cost of loading/unloading & installation.
c	Therefore savings in component maintenance in 10 Years	\$52,731.06	N/A	

**SUMMARY OF 10 YEAR COST SAVINGS USING LED LIGHT FITTINGS**

a	<b>INITIAL INVESTMENT ON LED</b>	\$134,618.53
b	<b>ENERGY</b>	\$20,338.90
c	<b>MAINTENANCE - LAMPS</b>	\$181043.6
	<b>MAINTENANCE - COMPONENTS</b>	\$52,731.06
	<b>TOTAL COST SAVING IN 10 YEARS</b>	\$254,113.36
	<b>Total Average Annual Saving</b>	\$25,411.336
	<b>Company Net Saving in 10 Years</b>	\$119,495
	<b>Annual Company Net Saving</b>	\$11,949.5

**National Benefits**

**V. Natural Gas Opportunity Cost:**

d	Natural gas valued using the wholesale price of \$4.618/MMBtu based on US Energy Information Administration Henry Hub/NYMEX futures prices; Equivalent energy rate of 5.6¢/kWh used to value the energy produced over 10 years, assuming 1% annual escalation factor.	\$5071.85
---	---	-----------

**VI. Pollution cost**

e	Carbon credits –based on current forward market @ 6 euro/ton, CO2 emission in kg/kwh: 0.83, Euro to USD exchange rate of 1.2.	\$451
	<b>National Benefit Saving in 10 Years</b>	\$5522.887
	<b>Total Benefits</b>	
	<b>Total Saving in 10 Years Operation</b>	\$125017.88
	<b>Total Net Average Annual Saving</b>	\$12501.788
	<b>Company Saving Norm = Annual Saving / kW (5) [10]</b>	\$330.55

S/N	Description	150 W MH Metal Halide [12]	65 W CREE LED [13]	Remarks
	Total Saving Norm = Total Net Average Annual Saving/ kW (6) [10]			\$345.83
<i>Economic Analysis</i>				
	Company Payback Period in Years (Initial investment for LED/Annual Company Net Saving)			11.27 Years
	Company Annual Return on Investment "ROI" in Percentage			8.88%
	Total Payback Period in Years (Initial investment for LED/Annual Company Net Saving)			10.77 Years
	Total Annual Return on Investment "ROI" in Percentage			9.29%

**Table 1.**  
 Summary of economic study for replacement of 150 W metal halide luminaire by 65 W LED luminaire.

<b>Total Benefits:</b>	
<b>Total Net Average Annual Saving</b>	<b>\$14,899.66</b>
Company Saving Norm = Annual Saving / kW (3) [10]	\$184.02
Total Saving Norm = Annual Saving / kW (4) [10]	\$360.29
<i>Economic Analysis</i>	
Payback Period in Years	4.632 Year
Annual "ROI" in Percentage	21.59%

**Table 2.**  
 Replacement of 400 W HPS lighting with (100–130) W CREE LED.

<b>Total Benefits:</b>	
<b>Total Net Average Annual Saving</b>	<b>\$2543.09</b>
Company Saving Norm = Annual Saving / kW (3) [10]	\$ 107.15
Total Saving Norm = Annual Saving / kW (4) [10]	\$127.15
<b>Economic Analysis</b>	
Payback Period in Years	10.93 Years
Annual "ROI" in Percentage	19.15%

**Table 3.**  
 Replacement of 1000 W MH lighting with (426) W CREE XAX LED.

From **Table 2**, it can be concluded that replacement of HPS lighting by LED lighting have the highest Total Net Average Annual Saving. Therefore, it is highly recommended to use LED lights instead of HID lights in industrial lighting applications.

It is also observed from **Table 4** that replacement Bollard Light Lamps by LED Lamp has highest economic value because of the very short lifetime Bollard Light Lamps compared with LED lifetime.

<b>Total Benefits:</b>	
<b>Total Net Average Annual Saving</b>	<b>\$9291.03</b>
Company Saving Norm = Annual Saving / kW (3) [10]	\$799.05
Total Saving Norm = Annual Saving / kW (4) [10]	\$819.31
<b>Economic Analysis</b>	
Payback Period in Years	8.657 Year
Annual "ROI" in Percentage	11.55%

**Table 4.**  
Replacement of 70 W bollard lighting with (34) W CREE EDGE LED.

<b>Project Total Investment</b>	<b>\$339,550.41</b>
<b>Project Total Average Annual Saving</b>	<b>\$39,235.9</b>
<b>Project Total Payback Period (Average)</b>	<b>8.654 Year</b>
<b>Project Annual Return on Investment "ROI" %</b>	<b>11.55%</b>

**Table 5.**  
Project economics.

In **Table 4**, project main economic indicators are illustrated with very attractive total payback period of 8.654 years and Project Annual Return on Investment of 11.55% which is higher approximately 10 times than the international bank rate for dollar deposit. This indicator supports the decision of investment in such scope of work.

In this Section, comprehensive economic study is carried out to calculate the Global Saving Norm for the replacement of High-intensity discharge lamps with different types by LED lamp in an Oil and Gas plant, which includes also the operational cost per year. The study considered Company direct benefits and National indirect benefits in evaluating project economic indicators and in calculating the Global Saving Norm as well. The result is compared and validated with previous research effort. Four important economic indicator were provided in this Section; Global Total Saving Norm (\$433.37/kW), Global Company Saving Norm (\$355.19/kW), typical total payback period of (8.654 year) and typical Project Annual Return on Investment of (11.55%). These four figures are important for both project decision makers and for cash-flow controllers.

### 2.2.3 Summary and conclusion

In Section 2 of this chapter, comprehensive economic study is carried out to calculate the Global Saving Norm for the replacement of High-intensity discharge lamps with different types by LED lamp in an Oil and Gas plant as "Case Study" representing industrial plant. The analysis considered Company direct benefits and National indirect benefits in evaluating project economic indicators and in calculating the Global Saving Norm as well. Four important economic indicator were provided in this Section; Global Total Saving Norm (\$433.37/kW), Global Company Saving Norm (\$355.19/kW), typical total payback period of (8.654 year) and typical Project Annual Return on Investment of (11.55%). These four figures are important for both project decision makers and for cash-flow controllers.

### **3. Smart LED lighting system used for long -roads with low-traffic for remote industrial plant**

#### **3.1 Survey and problem definition**

Various road classifications are existed in terms of traffic flow. Principal arterials, minor arterials, rural collectors, local roads and very low-volume roads. The last is what our concern in this section. Statistically, for low-traffic roads the flow rate of the vehicles is assumed to be 400 vehicles per day [14]. In these roads, even simple lighting system is not installed mostly, and authorities rely on vehicle lights to illuminate the roads, which putting people life and valuable product passing in these roads under the risk. The main reason of non-lighting system is the desired of saving electrical energy. The main reason of non-lighting system is the desired of saving electrical energy. However, continuously lightened fully roads cause wastage of electricity, as only one vehicles may appear every three or four hours and even more during the night time. Each of these two scenarios are contradicting and are extremely significant issues.

Several researchers did some projects and published their work related to this topic, however, none of them has considered the lighting automation system on low traffic road. Articles are mainly related to smart or automated main street lighting systems or parking areas. In the following paragraphs, several researches' results is discussed, and main points are drawn into attention.

Some studies proposed a suggestion to use two sensors in order to consume less power with maximized efficiency of a system [15]. Light Dependent Resistor (LDR) sensor is utilized to measure the sun light intensity to control the switching action of LED streetlights, and Passive Infrared Resistor (PIR) motion sensor is used for changing the intensity of LED light when there is no motion of object in the street at mid-night, then all the streetlights are dimmed. However, [16] indicates that LDR and PIR sensor are used for same purpose, but without dimming the light, just switched on or off. In [17], the author worked on this topic using Infrared Resistor (IR) sensors which measure the heat of an object as well as detects the motion, in contrast to previous researchers did. They developed the system using Arduino Uno R3 while [18] achieved the same by Raspberry Pi 3 micro controller.

Another research effort offered Zigbee Based Smart Street Light Control System Using LabVIEW. Here, movement is detected by motion sensors, communication between lights is enabled by Zigbee technology. So, when a passer-by is detected by a motion sensor, it will communicate this to neighboring streetlights, which will brighten so that people are always surrounded by a safe circle of light [19].

Another author developed Intelligent Street Lighting System Using GSM technology. The aim is to achieve the energy saving and autonomous operation on economical affordable for the streets by installing chips on the lights. These chips consist of a micro-controller along with various sensors like CO2 sensor, fog sensor, light intensity sensor, noise sensor and GSM modules for wireless data transmission and reception between concentrator and PC. The emissions in the atmospheres would be detected along with the consumption of energy and any theft of electricity [20].

Automatic street-light control system using wireless sensor networks is also proposed in some design. The system contains lamp station and base station [21]. Each lamp station consists of Arduino Uno board as microcontroller, PIR sensor, emergency switch, LDR sensor, nRF24L01 transceiver, ultrasonic sensor, relay, LED light and a solar panel as energy source. The base station consists of Raspberry Pi as processor, nRF24L01 transceiver, and a GSM module. The automatic

streetlight turns on under three conditions. Firstly, when PIR sensor detects a human or a moving object vehicle LED light is turned on. Secondly, an ultrasonic sensor is used to detect distance objects and turn on the light accordingly. Lastly, a switch is included for manual operation in case of maintenance work. The LDR sensor is included to measure the light intensity for identification of the day and night. There nRF24L01 wireless transceiver transmits the sensor information and the light status to the Raspberry web server to upload on the web page. Also, it receives commands sent from the web page to turn on or off the light at a particular node. The entire system is powered using solar cells making it more energy efficient.

The problem of high operational cost of low traffic light that use HPS lighting is partially solve by using LED light fitting instead of HPS luminaries [10].

Many real projects and researches have been done on this area [22–24], but few of them are focused in this topic exactly. Most of them consider street, campus, parking, park or any small area lighting system. The rest of them is devoted to road light and control systems. Brief analysis, discussion and comparison will be introduced hereinafter.

From the above literature review, firstly, all systems mentioned above used LDR sensor to sense night-time to operate the control system itself. In the system prosed in this Section, the same day/night sensor idea is also use to know exact hours of night-time or any dark time during the day time due to heavy cloud or any other reasons.

Secondly, all systems above have used motion sensors to detect the object movement whatever this object is, even if it is not vehicle, and hence control the lights in terms of switching ON/OFF or dimming. IR sensors and PIR sensor were the preferred sensors used to detect the object. These type of sensors detect mainly warm object and their movement. But, for the suggested system in this Section that need to be used for low traffic road, movement of only vehicle is needed to be recognized and hence switch on the light or dim them. The proposed system need to be designed to avoid any other motion such as animals, birds, or other objects which may be detected by IR or PIR sensors as this unnecessary detection of motion can cause unjustified energy consumption. Therefore, it is needed to give new approach to tackle with such problems. New approach could be to add the night vision smart camera to the system in order to recognize only the vehicles among all other objects that the camera detects.

Thirdly, some systems control the illumination by measuring the intensity of the objects movement and change the dimming of the lights accordingly. But for illumination system of low traffic roads, the intensity of the vehicles is continuously very low, and hence dimming technique is not effective solution.

Fourth, using LED light continuously operate during the night for low traffic roads can reduce the cost of illuminating the road compared with any other HID lighting, but still this is not best solution because the utilization of this system by this operational philosophy is not an efficient utilization because most of the time the light is ON unnecessary.

Fifth, in general, previous researches have been done on lighting automation system for the roads which serve both pedestrians and vehicles. But, this Section tries to design automation lighting system for long road with low traffic, where no need to switch on the lights for movement of any object except the vehicles.

In this section, efficient, safe and cost effective solution to design automated lighting system suitable for long roads with low-traffic is provided. First, description of the entire system design is discussed. Then, methodology and the programming of vehicles recognition using camera images are illustrated. Economic analysis for the proposed system is carried out. Finally, conclusion is given.



### 3.2 System design description

Lighting automation system in low traffic roads is intended to implement in the illuminated roads. It is supposed to have source power supply, feeder pillar with controller, light poles with day/night sensor. Such conventional system can be upgraded by new automated system. The methodology of lighting automation system in low traffic roads is achieved by applying the moving object recognition technique using cameras. Firstly, the road is sectionalized into several zones. Each zone depends on how much distance is existed between two feeder pillars, typically 400 meters. So, light poles in each zone will be switch on/off together. It means that each zone will have its feeder pillar (control panel) with controller, day/night sensor, motion sensor, and camera. Night vision cameras are installed on the road in such way to detect the vehicle arrival-to and departure-from each zone. The controller is designed to illuminate only the zones in which the vehicle is detected. The type and span of the zone are calculated based on the road design considering straight spans and roundabout.

#### 3.2.1 Lighting control conceptual design

The control scheme of the automatic lighting system is illustrated in **Figure 2**. Day/night switch detects darkness status to start the controller and hence motion sensor and night vision cameras. Now, let us consider that there are two adjacent zones (Zone N) and (Zone N + 1), and vehicle enters to Zone (N + 1). Mainly, day/night sensor and motion sensors of (Zone N + 1) need to be installed before the camera of (Zone N + 1), while camera of (Zone N + 1) need to be installed in (Zone N) near to the end. This is because camera need to start capture the moving objects images only after motion sensor detects any object in advance and sends the signal to the camera to start operation, and hence the controller takes the proper decision for switch the light of (Zone N + 1) before the object enter the zone.

For that, camera is installed on a light pole about 80 m before each zone. This distance provides approximately 2 seconds for data processing and control assuming maximum speed is approximately 60 km/hour. **Figure 3** illustrates the installation location of (Zone N + 1) camera, day/night sensor and motion sensors in (Zone N).

The software in the controller extracts the image from the camera and analyze it to determine whether the object is vehicle or not. If the object is not a vehicle, no action is taken by controller. In case the object is vehicle, signal shall be sent to Zone N + 1 lighting feeder pillar to switch on light of Zone N + 1 Simultaneously signal shall be sent to Zone N controller to switch off lightning system of Zone.

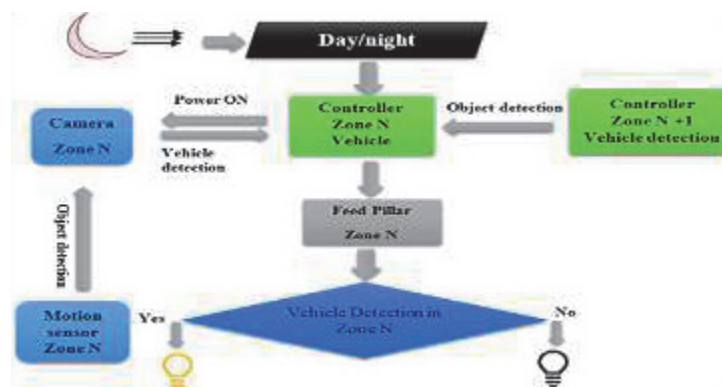

**Figure 2.**  
 Automatic lighting system schematic.

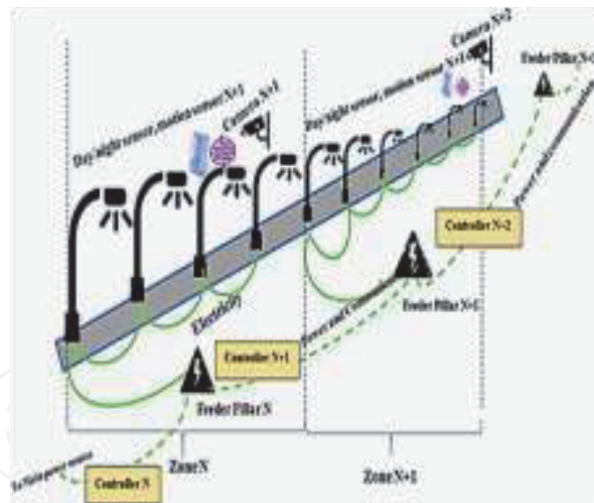

**Figure 3.**  
Zone definition.

### 3.2.2 Switching on/off lighting system for a zone

As we explained above, each Zone has its own lighting control system consists of Day/night switch, motion sensor, night vision camera, controller and feeder pillar.

When the controller of any zone detect “vehicles” the digital counter inside this controller counts the number of these detected vehicle ( $N_{in}$ ). In the same time, the same controller receives from the digital counter inside the controller of next Zone updated number of the vehicle interring the next zone ( $N_{out}$ ). The communication between the controllers can be achieved by Power Line Telecommunications method. or RS-485 cable. If the difference between the these to numbers ( $N_{in} - N_{out}$ ) is zero, this means that no vehicles exist in this zone, and the controller switches “Off” the light. As long as ( $N_{in} - N_{out}$ ) is not zero, the light of the zone will be kept “On”. This methodology insures that the lighting system for any zone is kept “On” if any vehicle(s) still in that zone for any reason such as accident, maintenance or temporary parking. Also, this methodology insures that the lighting system of the zone free of any vehicle is “OFF”.

In **Figure 4**, flow chart for two consequent lighting system control logic is illustrated.

## 3.3 Vehicle image recognizing

Several researches are done to recognize the vehicle at night based on vehicle lamp detection [25, 26]. This method will not work in case the vehicle lights are switches off for any reason. Another researches are carried out to detect the information in vehicle number-plate using artificial intelligent methods [27, 28]. However, using artificial intelligent method is time consuming and not useful for the application of the proposed system. In this application, recognition of the number-plate rectangular frame is simple method and more than enough to confirm that the moving object is “Vehicle”.

### 3.3.1 Methodology

The process of detection of vehicle number-plate consists of the following steps: capture of image, pre-processing, plate region extraction (**Figure 5**).

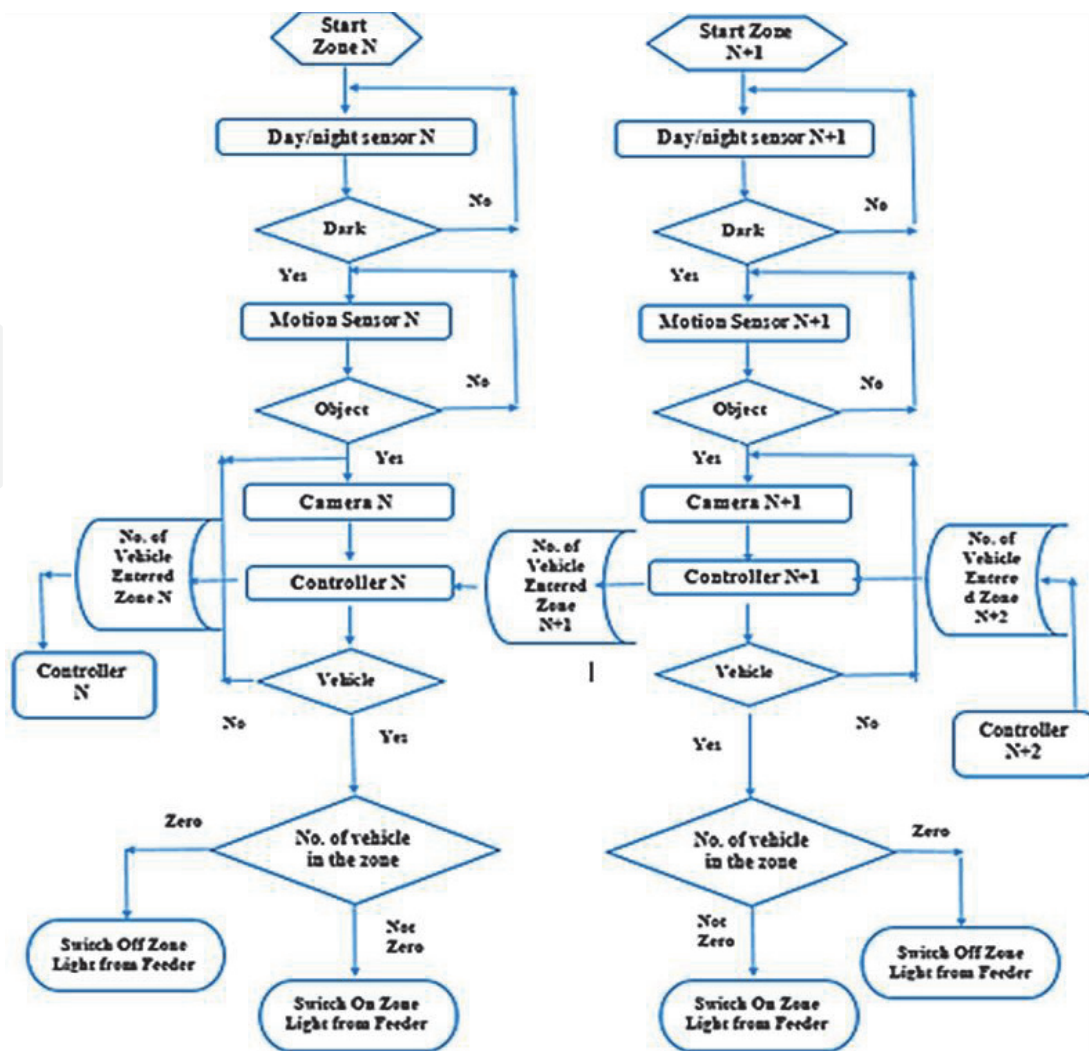

Figure 4.  
 Control flow chart for zone N and zone N + 1 lighting system.



Figure 5.  
 Vehicle recognition flowchart.

### 3.3.2 Capture of image

In this step, the image is captured by electronic devices such as infrared digital camera or any other camera suitable for night time. The image captured is stored in JPEG format. After that the captured image is converted into gray scale image.

### 3.3.3 Pre-processing

The next step after capturing the image is the pre-processing of the image. When the image is captured a lot of noises present in the image. Reducing the noises from the image are required to obtain an accurate result.

The RGB image is then converted into a gray scale image for easy analysis as it consists of only two color channels.

The aim of this pre-processing is to improve the quality of the image. Image enhancement techniques are used in this step. Image enhancement techniques consists process of sharpening the edges of image, contrast manipulation, reducing noise, color image processing and image segmentation.

### 3.3.4 Plate region extraction

The most important stage is the extraction of number-plate from eroded image significantly. The extraction of number-plate can be done by using image segmentation method. Mathematical morphology is used to detect the region of interest and Sobel operator are used to calculate the threshold value.

In general, any vehicle has its own number-plate which is always in rectangular shape consists characters. Accordingly, the basic approach in the detection of a vehicle is to recognize its number-plate which is mainly frame with characters (Numbers and letters). So, it is necessary to detect two criteria: the edges of the rectangular plate and there are characters within the rectangular.

A morphology based approach for detection number-plates is used. Our proposed method applies basic mathematical morphology operations like dilation and erosion.

The software model using the image processing technology is designed. The programs are implemented in MATLAB. The algorithm is divided into following parts: capture image, pre-processing, plate region extraction, characters recognition.

### 3.3.5 MATLAB code for number-plate recognition

The following MATLAB code is written to implement the above mentioned parts:

- Image capturing from camera  
% Read Image  
Input\_image = imread('Car.jpg');
- RGB to gray scale  
% Convert the truecolor RGB image to the grayscale image
- I = rgb2gray (Input\_image);  
The following steps are used:  
Image capturing from camera  
% Read Image  
Input\_image = imread('Car.jpg');  
RGB to gray scale  
% Convert the truecolor RGB image to the grayscale image  
I = rgb2gray (Input\_image);
- Edge detection  
% Sobel Operator Mask  
Mx = [-1 0 1; -2 0 2; -1 0 1];  
My = [-1-2 -1; 0 0 0; 1 2 1];



```
% Sobel Masking for filtering image  
S = imfilter (I, Mx, 'replicate');
```

- Vertical and Horizontal Dilation

```
% Vertical Dilation  
Dy = strel('rectangle', [80,4]);  
Iy = imdilate (M,Dy);  
Iy = imfill(Iy,'holes');  
% Horizontal Dilation  
Dx = strel('rectangle', [4,80]);  
Ix = imdilate(M,Dx);  
Ix = imfill(Ix,'holes');  
% Joint Places  
JP = Ix.*Iy;  
Dy = strel('rectangle', [4, 29]);  
ID = imdilate(JP,Dy);  
ID = imfill(ID,'holes');
```

- Erosion

The process of erosion reduces removing unwanted details from a binary image.

```
% Erosion  
E = strel('line',50,0);  
IE = imerode(ID,E);
```

- Filtering of digits

By filtering, the unwanted substances or noise can be removed or filtered out that is not a character or digits. Small objects or connected components should be removed and then the frame line that is connected to the digits should be identified and separated.

Bwareaopen (Image Processing Toolbox) is applied for removing all the connected components from the binary image that have value less than P pixels.

```
image2 = bwareaopen(image, min(numberofpixel, 100));
```

Stats = regionprops (L, properties) is applied for measuring a set of properties for each labeled region in the label matrix L.

```
stats = regionprops (image2,'all');
```

- Detect plate from image

### 3.3.6 Program validation process

The validation of the of the number-plate recognition program, and hence the detection of vehicle, is done by two tests.

#### 3.3.6.1 Number-plate recognized

In this first test it needs to insure that the program recognizes any object, that is captured by the camera, has number plat. Therefore, the test is carried out to detect the number plat for different vehicle models and types with different orientations. The test result is illustrated in **Figure 6**. The program succeeded to detect the number-plate as rectangular frame include characters. It is worth to highlight here that it is not part of the program function to “read” the number-plate.

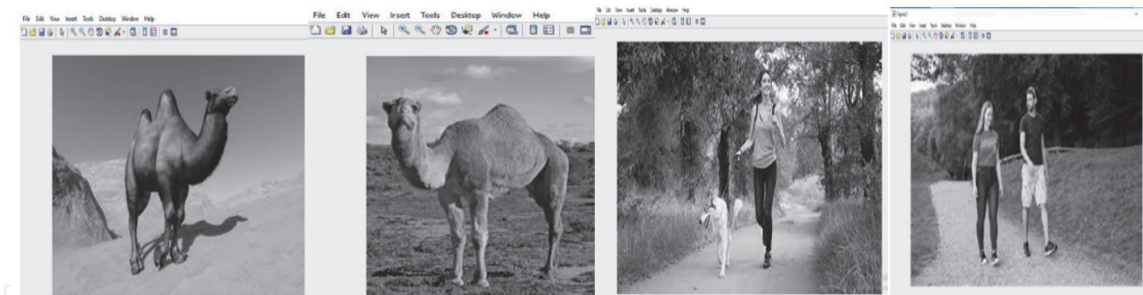



**Figure 6.**  
The results for objects with number-plate.

### 3.3.6.2 No number-plate recognized

The objective of the second test is to ensure that for any object that does not have number plate, the program shall detect no number-plate. The test is done using four images for different objects consist of peoples and animals - Camels and Dog- (Figure 7). The program also succeeded to detect no number-plate.



**Figure 7.**  
The results with non-car images.

### 3.3.7 Object recognition in the road

Any moving object enters any zone of the road shall be subject to two steps of recognition process: the first recognition process is by the motion sensor which detects that there is a moving object leaving the zone (serves-zone) and enters the next zone. The second recognition process is carried out by the image processing software that detects the moving objects which has rectangular plate with characters (Vehicle). If the two condition is satisfied simultaneously, the intelligent lighting system puts ON the road lighting of the next zoon (vehicle entering zoon) and switch off the lighting of the service-zoon after short time delay (vehicle leaving zoon).

## 3.4 Economic analysis

Comprehensive economic study is carried out with the same methodology discussed is Section 2, but to estimate the financial benefits of using the proposed

lighting automation system for the low traffic roads. The Study considers also Direct Benefit and Indirect Benefits [10] in order to evaluate the entire economic value of the system.

Assuming for low traffic; the vehicle flow is 400 vehicles per day [14], vehicle speed is 60 km/hour, zone distance is 400 meter, lighting pole span is 40 meter, LED fixture consumption per pole is 75 Watts [30] and electricity tariffs is typically (0.053\$) per kWh [29].

From the above assumptions, flow rate of the vehicle can be calculated to be 17 vehicles per hour. Considering worst road operation scenario, at which the 17 vehicles are driven with constant speed of 60 km/hour and equal distances from each other, it is obvious to conclude that one vehicle shall enter the first zone each 212 seconds and leaving the zone (400 meter) after approximately 24 seconds. Accordingly, the zone lighting fixtures shall be switched on for 29 seconds and switched off for 183 second approximately. From that, the percentage saving in power consumption using the proposed controller compared with the power consumption when road is illuminated continuously during the night is approximately  $183 \times 100/212 = 86\%$  saving.

Considering 4 km low traffic road operating for typically 50 years, Direct benefits and Indirect benefits can be calculated as following:

### 3.4.1 Direct benefit

#### 3.4.1.1 Initial cost of the new control system

Considering the cost of; camera (approximate number), day/night sensor, motion sensor, controller (simplest version) [31], signal transmission between zones by RS-485 network [32], and installation [10] (lamp, manpower, crane, dumping etc. ...), **Table 6** can be obtained. The table illustrates that approximately \$26,662.88 is needed to provide the proposed automation lighting system for 4 km.

#### 3.4.1.2 Energy saving

**Table 7** illustrates the comparison of energy consumption between using the proposed automation lighting system versus conventional system which operates all night, considering that both systems utilize LED fixtures with 75-Watt as minimum consumption for the conventional system. The table shows reduction in the power consumption of 86.31%. This reduces drastically the electrical fault probability in the lighting electrical circuits [33, 34].

S. No	Definition (in 4 km)	With controller	Without Controller
1	Total Quantity of LED	100	100
2	Quantity of Day/Night sensor, Motion sensor, Camera & Controller	10	0
3	Unit price for Day/Night sensor, Motion sensor, Camera & Controller including maintenance	\$107.40	\$0
4	Total cost for item 3	\$1074.00	\$0
5	Signal transmission between zones	\$14,698.88	\$0
6	Total Cost of Installation	\$ 10,890.00	\$0
<b>a</b>	<b>Initial Investment</b>	<b>\$26,662.88</b>	<b>\$0</b>

**Table 6.**  
Initial investment.

S. No	Description	With Controller	Without controller
1	Wattage per fixture (Watt)	75	75
2	№ fixtures in 4 km	100	100
3	Total power Consumed (Watt)	7500	7500
4	Operating hours (hour) per day	1.643	12
5	Daily operating cycle %	6.8458%	50%
6	Operating hours (hour) in 50 Years	29990.83	219,000
7	Power consumed per day (kWh)	12.325	90
8	Power consumed for 50 years (kWh)	224931.25	1,642,500
9	Total Cost for per day (\$)	0.65	4.77
10	Total Cost in 50 years (\$)	11,921.36	87,052.50
<b>b</b>	<b>Saving in 50 years</b>	<b>\$75,131.14</b>	

**Table 7.**  
*Energy saving.*

### 3.4.1.3 Saving in maintenance cost

**Table 8** indicates the maintenance cost saving [10] (in terms of light fixture) such as lamp, manpower, crane, etc. for 50 years' operation of the proposed automation lighting system and the conventional system.

### 3.4.2 Indirect benefits

In indirect saving, two benefits of implementing the lighting system will be drawn into attention [10].

#### 3.4.2.1 Natural gas sales opportunity

First benefit is natural gas sales opportunity (**Table 9**) gained from reduction of the power consumption calculated based on Eq. (1).

#### 3.4.2.2 Saving in pollution

Second benefit is the cost saving due to reduction of the CO2 emission, hence less pollution. (**Table 10**) calculate the related saving based on Eq. (2).

S. No	Description	With Controller	Without controller
1	Rated Life (Hours)	100,000	100,000
2	Operating hours in 50 years	29990.83	219243.33
3	Rate of maintenance in 50 years	0	2
4	Maintenance Cost per lightening pole	108.9	108.9
5	Total Maintenance \$	\$0.00	21,780.00
<b>c</b>	<b>Saving in Maintenance in 50 years</b>	<b>\$21,780.00</b>	

**Table 8.**  
*Saving in maintenance cost.*

S. No	Description	With Controller	Without controller
1	Annual Power consumption (kWh)	4498.63	32,850
2	Reduction in Power Consumption (kWh)		28351.38
3	Annual Natural Gas Sale Opportunity		\$1587.68
d	<b>Natural Gas Sale Opportunity in 50 years</b>		<b>\$79,383.85</b>

**Table 9.**  
*Natural gas sales opportunity.*

S. No	Description	With Controller	Without Controller
1	Annual Power Consumption (kWh)	4498.625	32,850
2	Power Consumption in 50 years (kWh)	224931.25	1,642,500
3	Annual Saving in Pollution		\$1694.2752
e	<b>Saving in Pollution in 50 years</b>		<b>\$84,713.76</b>

**Table 10.**  
*Saving in pollution.*

### 3.4.2.3 Total saving analysis

**Table 11** summaries the calculations in direct and indirect savings. It is obvious that total saving for only 4 km road in 50 years is \$ 234,238.47.

### 3.4.3 Discussion

To sum up, huge amount of money can be saved if such technique is implemented. In case that this system is applied to only 100 km road, total annual saving becomes about \$117,119.24; total saving in 50 years becomes \$5,855,961.75. It means that such system saves huge amount of energy and hence expenditure saving that can be utilized in other projects' investment. From is discussion, it is also possible to calculates the "Saving Norm" for the proposed system to be \$1171.19/km/Year (Eq. (3)).

## 3.5 Summary and conclusion

This Section provided automation design for the illumination system for low traffic roads in order to solve the problem of operating the road not only economically but also safely. Image recognition techniques was used based on identification

a	<b>Initial Investment</b>	\$ 26,770.28
b	<b>Saving in Energy</b>	\$ 75,131.14
c	<b>Saving in Maintenance</b>	\$ 21,780.00
d	<b>Saving in Natural Gas</b>	\$ 79,383.85
e	<b>Saving in Pollution</b>	\$ 84,713.76
F	<b>Total Saving Cost</b>	\$234,238.47
f	<b>Total Saving in 50 years</b>	\$ 234,238.47

**Table 11.**  
*Net saving analysis in 50 years.*



of vehicle number-plate to recognize the objects, is it vehicles or not? Image recognition algorithm was tested on different objects. The result from test has proved the validity of the algorithm that is used to detect different types of vehicle. Comprehensive techno-economic analysis was carried out and the result showed a great saving can be achieved, and hence, "Saving Norm" of \$1171.19/km/Year was calculated for the proposed system too. This "Saving Norm" is a good index to supports project management for both project decision makers and for cash-flow controllers. The calculated value of this "Saving Norm" index encourages the implementation of this technique in any Low-Traffic Long-Roads. This index is expected to be much higher, and hence more cost saving, in case road lighting uses HID bulbs instead of LED bulbs.

#### **4. Smart utilization of background lights for efficient indoor lighting intensity control**

The ways which are used today in order to light houses, offices, and most of indoor areas are inefficient as a lot of energy is consumed unnecessarily during the day time. This problem is also one of the design concern in Green Building. In this section, a solution to this problem and a method for people's comfort is presented. Lights switch on automatically when there is somebody in the room and switch off when there is no occupancy. In addition to this known technique, adjustment of the brightness level of the lights will be possible via the personal computer or any other smart device. In this method, for the illumination of the lights in the area, where is needed to be controlled, light automatically is measured by sensor and considering the amount of background light coming from outside, the brightness of lights automatically controlled to reach the preset level. By the means of this method, it is possible to provide both user comfort and energy saving [35].

##### **4.1 Survey and problem definition**

The energy wasting created by lighting is very significant in places where is multi-occupant, especially in offices. In Today's world, a lot of companies provide methods in order to minimize energy consumption, because energy consumption becomes a significant problem in developing world. Many researches show that lighting system accounts for approximately 30% of energy consumption [36]. Especially, departmental stores and big offices located in city territories causes a lot of energy consumption. In offices, lighting system consume approximately twice more than printers and computers [37]. One of the main causes of this problem is that people leaves lights "on" in unoccupied places. In almost 23% of the daytime this event occurs [38]. Another problem that causes to waste of energy is called over-illumination. Over-illumination occurs when lights are brighter than needed to illuminate room. In addition to this, researches demonstrate that excessive lighting can give rise to negative health effects [38]. This problem, however, still occurs in many structures everywhere, particularly in offices. Researches indicates that lights are off for just 1 percent of daytime while the room is unoccupied [39]. And this fact shows that over-illumination occurs during daytime because of external daylight coming into the room. And, in order to overcome these problems, implementation of intelligent lighting system can be a great solution.

The direct advantage of automated lighting system is to reduce energy consumption and maintenance cost. Energy consumption is reduced, because intelligent lighting system considers external daylight coming into the room and occupancy status, hence reduce the amount of power consumed. And, maintenance cost is minimized, since lifetime of the light bulbs is better utilized and this factor



extends the life span of light bulbs. In addition to this, indirect advantages of proposed solution are that it allows the country to export more oil and gas, since the consumption of fuel that is needed to generate electricity will be reduced due to the energy savings caused by intelligent lighting system. Also, a reduction in pollution can be considered as positive advantage as well, because when less energy is consumed, the amount of carbon dioxide emission released by power generation plants is reduced.

It is important to highlight that during the engineering phases of indoor lighting system, because of uncertainty of the amount of daylight and any other background light which penetrates the room, engineers ignore this factor in the design which consequently introduce several drawbacks in the operation and maintenance cost of lighting system. Typical level of illuminance for indoor lighting is given in **Table 12** [35].

It is clear from the minimum level of illuminance indicted in **Table 12** for each application that the design engineer has to consider the given value as Minimum. This make the designer not only ignore any background lighting contribution, but also it considers “Minimum” illumination level that allows the designer to go to higher values to satisfy other design criteria such as symmetrical distribution of lighting inside the room. Also, this “Minimum” value of the illuminance level considered the worst calculation safety-factors that may not be applicable in all cases. Therefore, in general, most of the time in day extra unnecessarily lux level can be obtained inside the room, and hence additional money for operation and maintenance need to be spent.

For better control of the indoor lighting and reduce the operation and maintenance cost of the lighting system, there are many methods to implement intelligent lighting system in order to provide more efficient lighting [40]. First method is to use occupancy sensor in offices, homes etc. In this method, sensor is used to detect occupancy in order to control lights. If there is somebody in the room, lights switch on, otherwise lights switch off automatically. This is a good straight forward and easy method reduce energy consumption but it is not the optimum solution as the method still ignoring the contribution of background lighting, therefore it cannot be considered as high efficient way to control the indoor lighting intensity.

Second method is to utilize daylight to adjust brightness to a preset level. Energy savings are controlled by using dimming technique in which percentage of illumination of light bulbs change according to daylight coming into the room. Researches show that dimming technique reduces energy consumption up to 30% compared to non-dimmable light bulbs [41]. Daylight utilization can be accomplished by using light sensors which is used in order to detect level of illuminance inside the room and adjust brightness of the light bulbs on the basis of amount of daylight measured in the room and desired set-point. The energy saving can increase depending on the performance of light sensors used. It is reported by Electric Power Research

Facility type	Area or task type	$E_{\min}$ (lux)
general	Entrance halls or corridors	100
offices	Typing, Writing, Reading	500
offices	Technical drawing/Working on computer	500–750
offices	Conference rooms/Archives	200–500
restaurant	Kitchen/Dining room	300–500
schools	Classrooms/Library and Laboratories	300–500
hospital	Waiting rooms/Operating theater	200–1000

**Table 12.**  
*Design average level of illuminance for various places.*

Institute that daylight utilization can increase energy savings up to approximately 40% [42]. In addition, researches indicate that energy savings can enhance up to 76% by taking into account daylight and occupancy status [43].

In this section, both above mentioned approaches are considered to develop intelligent lighting system in order to minimize power consumption and provide sustainable lighting system. Economic analysis is required to be carried out to evaluate this new approach.

This integrated approach enables us to adjust brightness of lamps to a preset level, considering daylight coming into the room and also prevent unnecessary lighting in unoccupied places. In the economic analysis, LED lighting type is selected as its power consumption is the lowest among other types of light bulbs, and hence it is expected minimum energy cost saving to be achieved. In case, other type of bulb is used, such as fluorescent or incandescent bulb, the energy saving due to using this intelligent lighting system shall be much higher.

## 4.2 Lighting control procedure

Energy consumption can be reduced significantly when light bulb's output is controlled automatically. Two methods are commonly used for lighting control. First method uses individual lighting control system in which each light bulb's output is adjusted independently according to light output level of its neighbor bulbs, the second method is networked lighting control system, which is more effective than the first method because all bulbs communicate intelligently with each other in order to achieve the required level for the room light intensity.

Networked lighting control system can be classified as DLCS (distributed lighting control system) for first method, or CLCS (centralized lighting control system) for second method. in DLC systems, each light bulb's sensing data is received by the controller, and they can communicate with neighbors in order to adjust their output level according to each other's state. However, in central unit CLCS which receives the status of each node based on information obtained from the sensors, and then performs control actions via actuators. In this system, central unit determines the output level of each light bulb on the basis of data obtained from sensors. In CLCS, many tasks are performed by central unit, such as, acquiring sensors' data from each node, estimating the optimal state where each light bulb will meet light requirements of the room (Figure 8).

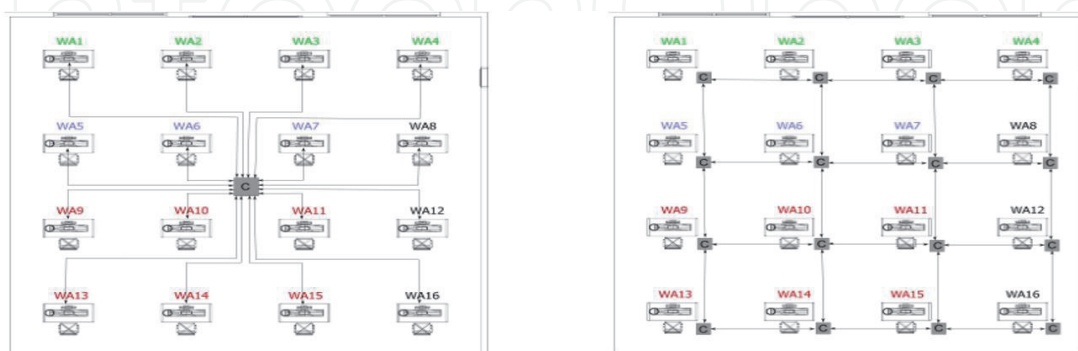

Figure 8.  
CLCS system and DLC system.

## 4.3 System description

PIR (Passive infrared) sensor is used to sense occupancy in places. PIR sensor detects occupancy at places and send commands to the controller to switch on or off

lights. Light intensity sensor(s) is used to give the controller the required data. The control unit sends signal to light dimmer(s) to control the LED light imitation to achieve the preset Lux level required for the room considering daylight.

#### 4.3.1 Intelligent lighting systems methodology

The term called intelligent luminaire is connected to a smarter level of illumination where devices are capable of creating lighting comfort, energy efficiency, and easy controllability. The concept which is named intelligent lighting system corresponds to a system that communicates and cooperates with many luminaires, creating a node that satisfies user requirements. The key goal of this kind of system is to save energy and, at the same time user comfort by the means of network communication. In **Figure 9** the block-diagram of intelligent lighting system is illustrated. It is assumed that lighting system is dimmable (controllable) in order to provide intelligent method to tune the Lux level to the present value determined by the controller.

Firstly, this system checks for occupancy. If there is no occupancy, Arduino controller sends commands to AC light dimmer (which is controlling the intensity of light bulbs) to switch off lights. If there is somebody in the room, PIR sensor detects occupancy inside the room and activate Arduino controller. Consequently, the controller sends signal to the dimmer(s) to switch on the light and tune the lux of the room to achieve the preset value based on the input provided by the light intensity sensor(s).

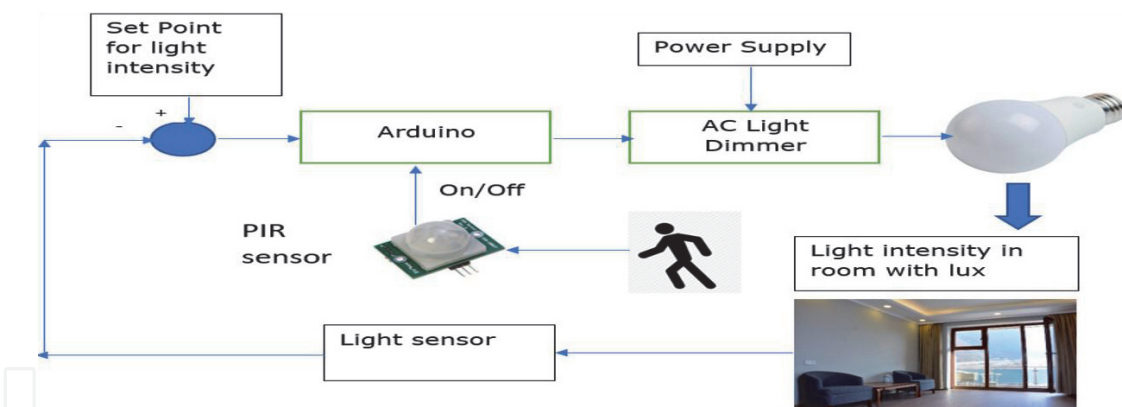

**Figure 9.**  
*Block diagram of intelligent lighting system.*

#### 4.3.2 Intelligent lighting system components

The intelligent lighting system contains PIR sensor, BH 1750 light sensor, Arduino Mega, AC light dimmer, LED and light bulb.

PIR sensor is used to detect occupancy in the room. Light sensor is used to measure the amount of light in lux. Arduino Mega is used as a controller. Ac light dimmer is used in order to adjust the brightness of LED bulb. To monitor the amount of light (PV) and set point (SP), LCD is used. LED bulb is used to provide illumination in the room.

PIR sensor is one of the simplest and inexpensive type of occupancy sensors and this type of sensor is widely used around the world. It is capable of measuring various air temperatures in the room. When there is somebody in the room, sensor sends a signal to turn on or off lights. When object is moved in the sensor's field of view, infrared lights which is radiating from the objects are measured by PIR

sensor. People have a temperature that is higher than perfect zero and thermal energy is emitted from people in the form of radiation. During the day, the wavelength of radiation is approximately 9–10 micrometers. PIR sensor has capability to detect the wavelength of radiation which only arise when a person comes to sensor's field of view. The radiation emitted by all objects which has temperature above absolute zero cannot be seen by human eye, since it is emitted at infrared wavelengths, however, electronic devices, such as PIR sensor, can detect it. This kind of sensors works totally by sensing the energy emitted by objects. When the amount of heat varies in intensity or position, sensor activates the controller.

PIR sensor which is used in this Intelligent Lighting System possesses pyro-electric sensor module that is designed for the detection of human body. This sensor has sensing range from 3 m to 4 m, and lens angle is about 140 degrees [44]. One of the advantages of PIR sensor compared with other types of occupancy sensor is that it is not complex, effortless to install, and it has compact size which is 28\*28 mm. In addition to this, it is highly sensitive, power consumption is very low, and can perform under temperature from -15 to 70 degree. Most significantly, as contrasted with other sensors, it can penetrate walls in which motion can be anticipated and it is cheaper compared with other sensors. However, a constant and slight motion cannot be detected by PIR sensor and this sensor is sensitive to temperature. Another negative side of this sensor is that its field of view is smaller than other type of occupancy sensors. Moreover, this sensor cannot be mounted near the places where temperature changes commonly. But for application of indoor industrial building, this sensor is adequate to be used.

BH1750 sensor is used in order to measure light intensity inside the room. This is a digital light sensor and it is used in the majority of mobile phones in order to adjust screen brightness, depending on lights coming from outside. This sensor has capability to measure directly lux value and there is no need to convert measured value to lux. This sensor uses I2C protocol to communicate with the controller. This protocol makes it easy to use with microcontroller. SCL and SDA pins which sensor have are required for I2C protocol. One of the advantages is that there is no need for calculation because we can get directly lux value by the means of this sensor. This sensor measures light intensity based on the amount of light which is hitting on it. The voltage between 2.4 V and 3.6 V and 0.12 mA current is needed to operate this sensor. The main component of BH1750 sensor is illustrated in **Figure 10**.

Arduino Mega is used as a master to control all slaves. It is the brain of this Intelligent Lighting System. It is a type of microcontroller board and uses ATmega 2560 microcontroller. Arduino Mega has 70 I/O pins. Fiftyfour (54) pins of Arduino Mega are digital I/O pin and 14 of them can be used as PWM pin. Other 16 pins are

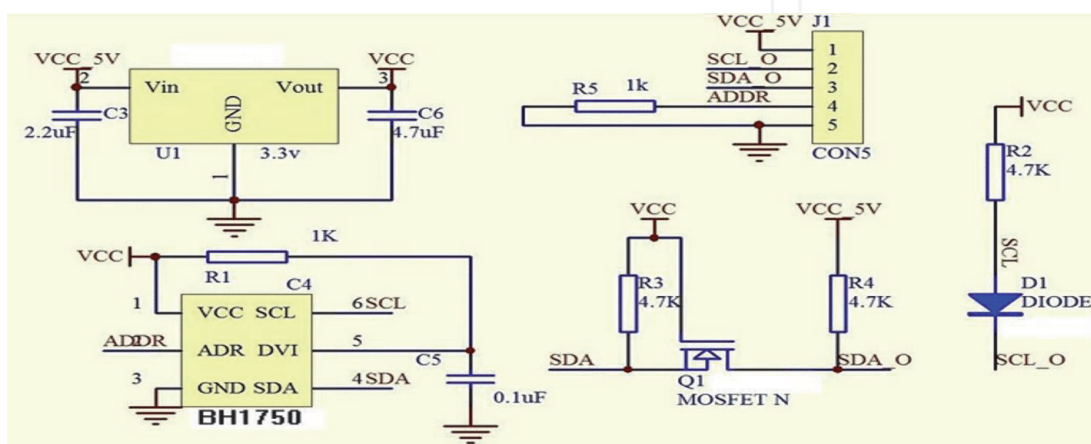

**Figure 10.**  
BH 1750 sensor circuit.



analog I/O. In addition to this, it consists of 4 UARTs, 16Mhz crystal oscillator, USB connection, power jack, ICSP header, and reset button. Arduino Mega can simply be connected to the computer and programmed. There are many types of shields used for several purposes can be added to the Arduino mega [13].

LED light bulbs are the best choice to use in energy saving lighting systems and they have great advantages over the fluorescent lamps and incandescent light bulbs. In these days, LED bulb technology has developed and this technology offer light bulbs which can be used for many applications. In addition to this, this type of light bulbs offer dimmable and non-dimmable options and it creates opportunity to be used in intelligent lighting systems. LED bulbs are very durable and no mercury is used in this type of bulbs. Although the initial cost of LED bulbs is higher than other types of bulbs, they are cheaper to use for overall life of the light bulb compared with fluorescent or incandescent light bulbs. For all of these reasons, it can be beneficial to use led bulbs instead of other types of bulbs in the Intelligent Lighting Systems [44].

AC Light Dimmer is used to adjust the light intensity by dimming the light bulb [45]. There are various methods for dimming, the usual way is to use variable resistor which change the voltage coming into the lamp. Nevertheless, when variable resistance is used in order to change the brightness of lamp, resistance converts some part of energy into the heat that is not used. An effective method for dimming is to turn off AC power regularly and provide only some portion of full wave to the light. It could sound strange at first, because it will produce flicker, however it is not visible by human eye, if the periodic light switches and phase of AC power are locked. In order to accomplish the dimming, two circuits are required, zero-crossing detector and pulse-controlled switch, respectively. This is used in order to maintain switching with the power source in phase. And, to deal with 220 V AC, safety precautions should be implemented. That is why, circuit should be mechanically and electrically isolated from outside by the means of metal box and optoisolators, accordingly. The zero-crossing detector is a full wave rectifier with high power resistors that is used to reduce voltage (**Figure 11**). And, the pulse-controlled switch contains a Diac or Triac.

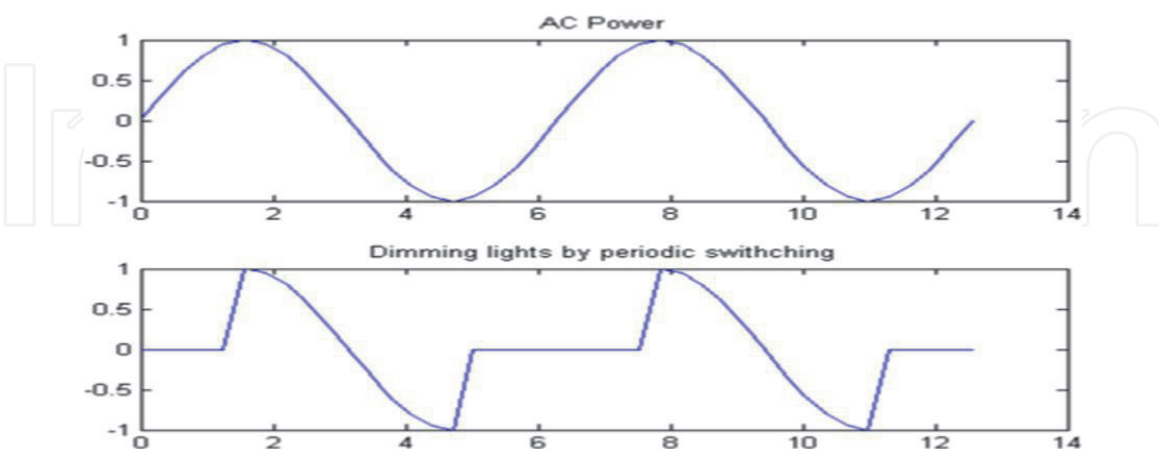

**Figure 11.**  
*Pulse control using AC light dimmer.*

#### **4.4 Intelligent lighting system response**

The response of system will be illustrated for three different preset values and three background in the room. The response of the system will be represented for occupied conditions. In unoccupied conditions, the intensity of light bulb will be set



automatically to zero lux. In **Figure 12**, the response of the system is illustrated for preset value of 75 lux and external daylight with the amount of 25, 50, and 75 lux, ascending and descending. Another case is considered in **Figure 13** represents the response of the system for setpoint of 150 lux and additional daylight with the amount of 50,100, and 150 lux, ascending and descending. And last test case is considered in **Figure 14** shows the response of the system for setpoint 300 lux and external daylight with the amount of 100, 200, and 300 lux, ascending and descending. It is obvious from the results, the dimmer adjusts the light intensity of light bulb to achieve successfully to the present value, considering the external light coming into the room.

The transient state of the system response is not described in these graphs, only steady state is taken into account, since human’s eye does not recognize to the fast changes happen in the amount of light. Moreover, in general, the rate of the change in the daylight occurs slowly and gradually, consequently, the response of the controller will change the intensity of the light emitted from the controlled lighting system in small steps which are comfortable for the eye. Hence, the transient state is not concern for the proposed intelligent lighting system.

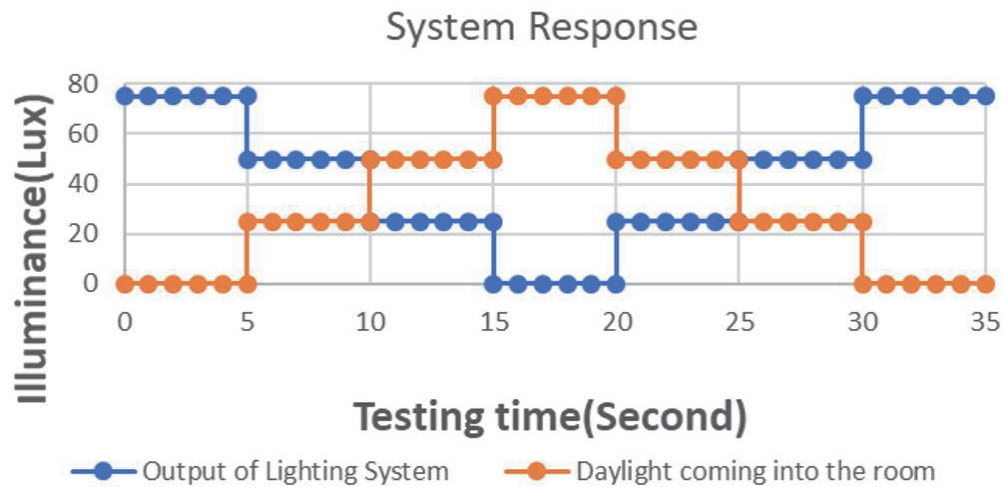

**Figure 12.**  
The response of system for 75 lux SP.

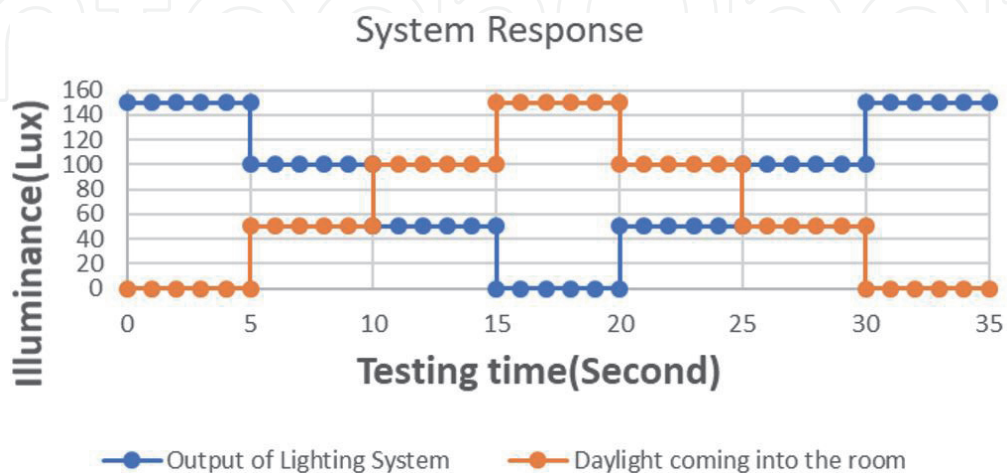

**Figure 13.**  
The response of system for 150 lux SP.

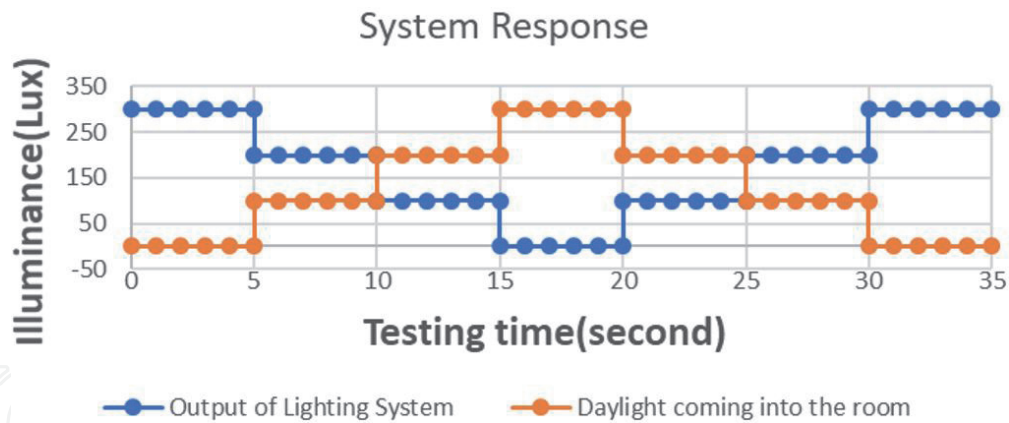

**Figure 14.**  
 The response of system for 300 lux SP.

## 4.5 Economical evaluation

In this section, Techno-Economical evaluation is discussed that includes direct and indirect benefits obtained from using the proposed intelligent lighting system. As mentioned earlier in this Chapter, Direct benefits are categorized in two parts; operational and maintenance cost. However indirect benefit is categorized also into two parts, introducing more oil/gas sale opportunity and reduction of pollution. And, the cost of this intelligent lighting system is negligible compared with other lighting systems [46, 47].

### 4.5.1 Direct benefits

Direct benefits of the proposed Intelligent Lighting System are explained as following:

#### 4.5.1.1 Reduction of operational cost

This section determines the energy gains that intelligent lighting system can provide during the day. In order to achieve this, the response of controller is assumed to be maintained during the day. By considering occupancy status and level of illuminance during the day, energy savings which intelligent lighting system can provide may be calculated. Survey [37] illustrates that workers' illuminance preference is approximately 300 lux, and energy waste is generated by over-illumination and turning on lights in unoccupied places.

In **Figure 15**, Data of illuminance and occupancy status during the day and workers' illuminance preference in typical open-office are illustrated. In this survey, it is assumed that approximately 60% of daylight is coming into the room. From **Figure 15**, it can be observed that workers arrive at office at approximately 9:00 AM, occupies the working area and turn on the lighting system, because the level of illuminance is less than 300 lux (However, lighting system plus daylight coming into the room provides more than 300 lux). Thus, at the end of working hour, the lighting system was switched off about at 19:00. Also, from It can also be observed that workers leave working area at different times of the day, but lighting system turned on by causing the energy waste. In addition, between 15:00 and 17:00 the illumination which is generated by daylight is sufficient to satisfy the

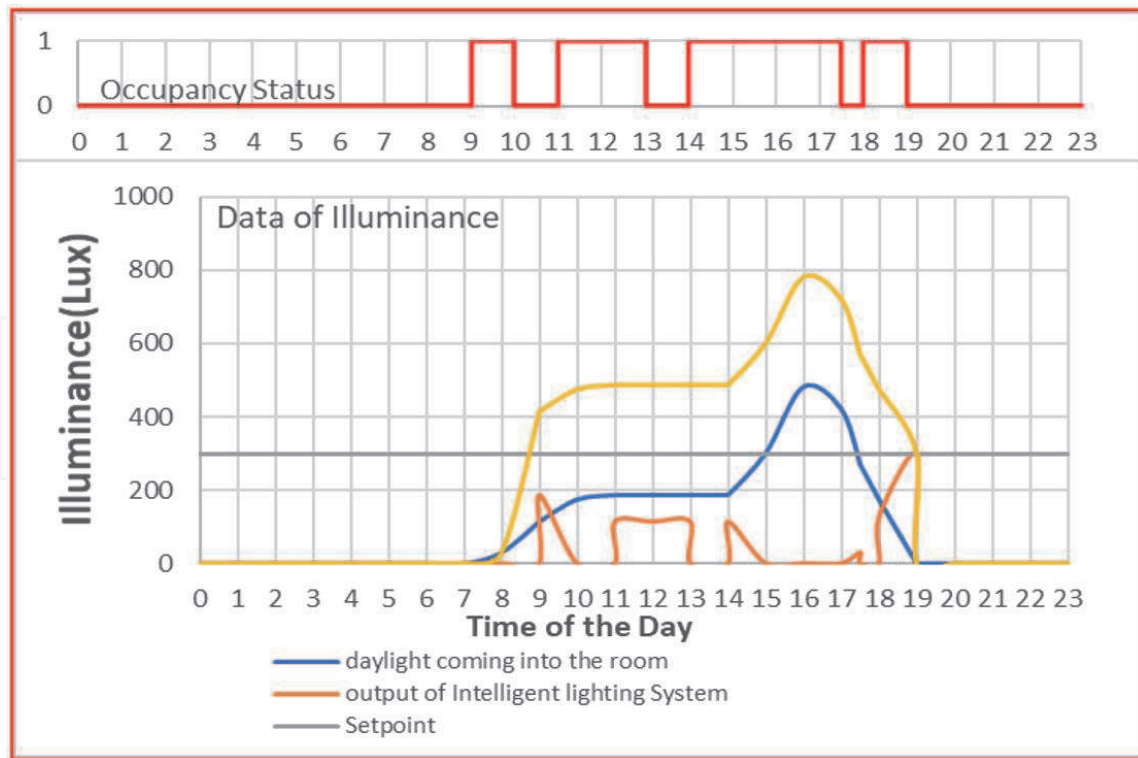

**Figure 15.**  
Data of illuminance and occupancy status in typical open-office.

illuminance requirement at the office and lighting system is however switched on by causing over-illumination.

This data represents that thanks to daylight utilization technique, energy can be saved significantly between 9:00 and 19:00 by controlling the amount of light provided by the lighting system. In addition to this, occupancy sensor will contribute us to save energy by switching off lighting system when there is no occupancy in the working area. Finally, the energy savings can be calculated from the **Figure 15** by comparing the Areas under the curves. In order to find the energy savings, the area of curves, which are generated by the outputs of intelligent lighting system and Setpoint, should be calculated between 9:00 and 19:00. And, using the following equation, the percentage of energy savings accomplished from intelligent lighting system can be estimated.

$$A_1 (\text{Energy for Traditional Lighting System}) = 10 * 300 = 3000 \quad (6)$$

$$A_2 (\text{Energy for Intelgent Lighttting System}) = 95 + 240 + 55 + 8 + 150 = 548 \quad (7)$$

$$E.S(\text{Energy saving}) = (3000 - 548)/3000 * 100\% = 81.7\% \quad (8)$$

From the equation above, it is calculated that in typical open-office energy savings can be approximately 81.7% by implementing proposed intelligent lighting system.

#### 4.5.1.2 Reduction of maintenance cost

In **Figure 15**, it is clearly seen that operation hours of light bulbs reduce from 10 hours to approximately to 5.5 hours. So, implementation of proposed intelligent lighting system contributes also to reduce maintenance cost. The life span of light bulbs increases significantly, since lights are switched on at certain times of the day.

From **Figure 15**, percentage of reduction of maintenance cost can be calculated by the means of following equation.

$$M.C(\text{maintenance cost}) = (10 - 5.5)/10 * 100 = 45\% \quad (9)$$

From the equation above, it is calculated that in typical open-office, maintenance cost can be reduced about 45% by implementing proposed intelligent lighting system.

#### 4.5.2 Indirect benefits

Explanation of indirect benefits will be given in detail in the following paragraphs.

##### 4.5.2.1 Annual gas sale opportunity

First benefit is that country can export larger amount of gas, since the consumption of gas will be reduced due to the energy savings caused by proposed intelligent lighting system. By using the selling price of \$4.618/MMBtu on the basis of US Energy Information Administration Henry Hub/NYMEX, natural gas valued futures prices. Considering 1% annual escalation factor, equivalent energy rate of 5.6¢/kWhr used to measure the energy generated for one year. And, sales opportunity for the natural gas can be estimated annually by the means of equation Eq. (1) that can be used to calculate the annual gas sale opportunity for any project using this Intelligent Lighting System.

##### 4.5.2.2 Annual saving in pollution

Second indirect benefit is that pollution caused by power plants can be reduced significantly. When the amount of power consumed is reduced, the amount of toxic fumes released by power plants will be reduced. The majority of power plants burn crude oil, coal, fossil fuel etc. Hence, this causes the emission of carbon dioxide that accounts for the majority of pollution. Carbon dioxide is released into the air and causes the absorption of sun's warmth and heat in our atmosphere. When power plants burn more fuel in order to generate more energy, extra carbon waste traps cause too much heat. When carbon dioxide emission is reduced, it will cause less pollution. Eq. (2) can be used to calculate the Annual Saving in Pollution that can be gained in any project using this Intelligent Lighting System.

#### 4.5.3 LED bulbs

Nowadays, energy saving is one of the big problems, that is why energy-efficient lighting systems proceed rapidly over the past ten years [43]. Led light bulbs are the best choice to use in energy saving lighting systems and they have great advantages over the fluorescent lamps and incandescent light bulbs. In these days, led bulb technology has developed and this technology offer light bulbs which can be used for many applications. In addition to this, this type of light bulbs offers dimmable and non-dimmable options and it creates opportunity to be used in intelligent lighting systems. Led bulbs are very durable and no mercury is used in this type of bulbs. Although the initial cost of Led bulbs is higher than other types of bulbs, they are cheaper to use for overall life of the light bulb compared with fluorescent or incandescent light bulbs. For all of these reasons, it can be beneficial to use led bulbs instead of other types of bulbs in lighting systems.



#### *4.5.3.1 Diffused led bulbs*

One of the bunch of LED bulbs is diffused LED bulbs. It is covered by lens which have dimple shape, and this shape support to spread light around a big area. Nowadays, because of their tremendous efficiency, people increasingly use this type of bulbs. This type of bulbs is available in standard Edison bases, and they can be used for a lot of purposes, such as, reading lamp, lighting for rooms and offices, and some other applications in which light can remain on for a long time.

#### *4.5.3.2 Flame tip, Candelabra Base LEDs*

Flame Tip, Candelabra Base LED bulbs is another type of LED bulbs and it is used in many applications. The purpose of designing such type of light bulbs is to take the place of incandescent candelabra bulbs. This type of light bulbs is significantly effective because they can deliver corresponding light of 25 to 35 W and light does not spread top to bottom as far as typical lights, because of heat sink.

#### *4.5.3.3 Led tube lights*

LED Tube Light bulbs is another type of LED light bulbs and it is used in a lot of applications. The purpose of designing this type of light bulbs is to replace typical fluorescent tube lights. They exist in 8 and 16 W. In commercial sites, fluorescent lights are frequently installed in high ceilings and using Led Tube Lights instead of fluorescent tube lights is extra saving, because the frequency of replacing bulbs is significantly decreased.

#### *4.5.3.4 Advantage of led bulbs*

The life of LED bulbs is approximately 10 times more than incandescent and fluorescent light bulbs. The main reason why they are more effective is that they do not have filament and they are not destroyed under conditions in which typical incandescent and fluorescent light bulb can be damaged. This type of bulbs does not cause any heat, but common incandescent lamps heat and help to increase the room temperature. LEDs avoid this problem and contribute to reduce the air conditioning cost. In the manufacturing process of LED bulbs, no mercury is utilized and this kind of bulbs use approximately 2–17 W electricity. LED bulbs reduce electricity cost, remain cool and avoid the replacement cost, because they have long life.

#### *4.5.3.5 Cost comparison among light bulbs*

Although, initial cost of LED bulbs is higher, this cost compensates over time in electricity saving. The use of LED bulbs commercially adopted, because maintenance and replacement cost was significantly higher. Maintenance and replacement cost in LED bulbs are considerably less compared with others and the initial cost of LED bulbs is continuing to decrease.

#### *4.5.4 Saving norm calculation*

Consider standard office with dimension 3mx4m. As per **Table 12**, the design lux level is 500 lux. Using matrix distribution 2x2 with 60cmx60cm light fitting, each consists of 4 lighting tube Fluorescent (25 W) or LED (9 W), the office Traditional lighting load shall be 400 W or 144 W respectively. For 9 hours working duty, the annual consumption shall be 4730kWh and 1314kWh.



Conditions	Led Bulbs	CFL	Incandescent
Light bulb projected Lifespan	50,000 h	10,000 h	1200 h
Watts for per bulb	10	14	60
Cost for per bulb	\$35.95	\$3.95	\$1.25
KWh of electricity used over 50,000 hours	300–500	700	3000
Cost of electricity (0.10per KWh)	\$50	\$70	\$300
Bulbs needed for 50 k hours of use	1	5	42
Equivalent 50 k hours bulb expense	\$35.95	\$19.75	\$52.50
Total cost for 50 k hours	\$85.75	\$89.75	\$352.50

**Table 13.**  
*Economic comparison between LED, CFL and incandescent bulbs.*

Applying Equation-9, the office annual energy consumption can be reduced to 865.59kWh and 240.462kWh for Fluorescent lighting and LED lighting respectively.

From **Table 13**, cost of electricity (0.10per KWh). Accordingly, from two the values, 865.59kWh and 240.462kWh, Annual Energy Saving Norm/Office for offices using Fluorescent lighting and LED lighting can be calculated to be 86.6 \$/office and 24\$/office respectively. For example, if this technique applied on 100 Administration Building with 50 room each, so the total Annual Saving can be 433,000 \$ and 120,000\$ for Fluorescent lighting and LED lighting consequently. This example gives good impression how much reasonable saving can be obtained by applying such technique in industrial buildings.

#### 4.6 Summary and conclusion

To conclude this section, it can be highlighted that most places are over illuminated because background light is not considered in the design sage. In addition, light is switched on in unoccupied places which causes waste of energy. Therefore, Intellect Lighting System is very essential to overcome this problem to control indoor lighting intensity taking into account occupancy status and background light coming into the room in order to adjust level of illuminance in efficient way. As a result, it is worth to highlighted that Intelligent Lighting System uses properly selected LED bulbs not only reduces power consumption, but also reduces maintenance cost, pollution caused by power plants and increases opportunity for gas sales. Finally, typical Annual Energy Saving Norm (Energy Saving\$/Office) is calculated for both cases, offices using Fluorescent lighting and LED lighting.

IntechOpen

IntechOpen

### **Author details**

Muhammad M.A.S. Mahmoud  
Baku Higher Oil School, Baku, Azerbaijan

\*Address all correspondence to: [mmanar@yahoo.com](mailto:mmanar@yahoo.com)

### **IntechOpen**

---

© 2021 The Author(s). Licensee IntechOpen. This chapter is distributed under the terms of the Creative Commons Attribution License (<http://creativecommons.org/licenses/by/3.0>), which permits unrestricted use, distribution, and reproduction in any medium, provided the original work is properly cited. 

## References

- [1] Lighting Research Center-Ekobase, Advantage of Using Energy Efficient Lighting for Society and Environment; 2020. <https://www.ekobaseglobal.com/index.php/en/learning-center/street-lighting-technology-comparison>
- [2] Illuminating Engineering Society, Illuminating Engineering Society of North America Had Book (IESNA); 2000.
- [3] LED advancements drive quality of light gains (MAGAZINE). LEDs Magazine. 22 April 2014.
- [4] Y.K. Cheng, K.W.E. Cheng, "General Study for using LED to replace traditional lighting devices", IEEE 2nd International Conference on Power Electronics Systems and Applications, 2006.
- [5] Muhammad M.A.S. Mahmoud, Detection of Single-Line-to-Ground Faults Through Impedance in Mesh Distributed Network, IEEE conference Modern Electrical Power System MEPS-15, Wroclaw, July 2015.
- [6] Evangelos-Nikolaos D Madias, Lambros Doulos &, others, A decision support system for techno-economic evaluation of indoor lighting systems with LED luminaires, Journal of Operational Research 2019, DOI: 10.1007/s12351-019-00485-1, SpringerLink,
- [7] Leena Tähkämö, Rami-Samuli Räsänen & Liisa Halonen, Life cycle cost comparison of high-pressure sodium and light-emitting diode luminaires in street lighting, The International Journal of Life Cycle Assessment, volume 21, 137–145(2016).
- [8] Nibedita Das\* , Nitai Pal, Sadhu K. Pradip, Economic cost analysis of LED over HPS flood lights for an efficient exterior lighting design using solar PV, Building and Environment, Vol. 89, pp 380–392, Elsevier July 2015.
- [9] Chin KimGanAhmad Farid SaparYik Chee MunKuan Eng Chong, Techno-economic Analysis of LED Lighting: A CaseStudy inUTeM's Faculty Building, Malaysian Technical Universities Conference on Engineering & Technology 2012, MUCET 2012, Procidia Engineering, Vol 53. Pp 208–216, 2013, Elsevier.
- [10] Muhammad M.A.S. Mahmoud, Typical Economic Model for Calculating the Saving Norm of Replacement HPS Street Lighting by LED Fixtures in Access Road of Gas Production Company at GCC, IEEE - International Conferences on electrical and electronics engineering, 4–7 may 2018 (ICEEE 2018) Istanbul.
- [11] The Emirates Center for Strategic Studies and Research, Technology and The Future of Energy, 2013.
- [12] Lighting Handbook 10th Edition - IES - Illuminating Engineering Society. ISBN # 978-0-87995-241-9.
- [13] Cree Edge™ LED Luminaire. Cree Catalogue. Retrieved 9 October 2017.
- [14] Cornell University. "What is the traffic volume cut off between high-volume and low volume?" Cornell Local Roads Program. <https://www.clrp.cornell.edu/q-a/151-low-volume.html#:~:text=1%2C000%20vehicles%20per%20day%20is,upon%20context%20including%20functional%20classification>.
- [15] P. V. K. Bhangdiya, "Low Power Consumption of LED Street Light," International Conference on Global Trends in Signal Processing, Information Computing and Communication, 2016.
- [16] Noor Lina Ramli, N. Mohd Yamin, "Implementation of passive infrared sensor in street lighting automation

system,” *ARPN Journal of Engineering and Applied Sciences*, 2015.

[17] Sindhu.A.M, Jerin George, Sumit Roy, Chandra J, “Smart Streetlight Using IR Sensors,” *IOSR Journal of Mobile Computing & Application (IOSR-JMCA)*, 2016.

[18] Ms. M. Kokilavani, Dr. A. Malathi “Smart Street Lighting System using IoT,” *International Journal of Advanced Research in Applied Science and Technology* ISSN, 2017.

[19] Faiz Ansari, Saima Khan , Aakash Jaiswar , Pooja Khiste , Milind Nemade, “Zigbee Based Smart Street Light Control System,” *International Journal of Innovative Research in Science, Engineering and Technology*, 2016.

[20] Aman Kumar Akash Oraon Siddharth Agarwal, “Intelligent Street Lighting System Using Gsm,” *International Journal of Engineering Science Invention*, 2013.

[21] D.S.A.S. Rajasri, “Automatic street light control system using wireless sensor networks,” in *IEEE international Conference on Power, Control, Signal and Instrumentation Engineering*, 2017.

[22] Tvilight, “Energy savings through dynamic dimming on the S100 in Nijmegen”, *Intelligent Roadway Lighting*. <https://www.tvilight.com/2016/10/18/case-study-public-roadways/>.

[23] Intelilight, “Intelligent Street Lighting,” <https://intelilight.eu/>.

[24] Muhammad M.A.S. Mahmoud “Economic Model for Calculating the Global Saving Norm of Replacement High-Intensity Discharge Lamps with LED Lamp in Oil and Gas Plant”, *IEEE 61st International Scientific Conference on Power and Electrical Engineering of Riga Technical University (RTUCON)* 2020.

[25] Reham Faour, Bassel Shanwar, Nizar Zarka, “Recognition of Vehicle Numberplate using MATLAB”, DOI: 10.13140/RG.2.1.1459.8640, 2016.

[26] M. K. B. Ashan and N.G.J.Dias, “Recognition of Vehicle License Plates using MATLAB”, *European International Journal of Science and Technology* Vol. 5 No. 6 , August, 2016.

[27] Jing-Ming Guo ; Chih-Hsien Hsia ; KokSheik Wong and others, “Nighttime Vehicle Lamp Detection and Tracking With Adaptive Mask Training”, *IEEE Transactions on Vehicular Technology*, Vol. 65 , Issue: 6 , June 2016.

[28] Hazim Hamza Supervisor, Paul Whelan Night, “Time Car Recognition Using MATLAB”, *M-Eng in Electronic Systems* 2013

[29] Republic, “tariffcouncil.gov.a z,” 2016. <http://www.tariffcouncil.gov.a z/?/az/content/70/>.

[30] Pacificlamp.com, <https://pacificlamp.com/street-light.asp>.

[31] A. A. Circuits, “Low-Cost Programmable Logic Controllers for the Frugal Engineer,” <https://www.allaboutcircuits.com/news/low-cost-programmable-logic-controllers-for-the-frugal-engineer/>.

[32] Alibaba, “Signal 2cores twisted pair armoured rs485 cable price,” [https://www.alibaba.com/product-detail/Signal-2cores-twisted-pair-armoured-rs485\\_62193928910.html?spm=a2700.7724857.normalList.9.38b06425h3AeQA&cs=p](https://www.alibaba.com/product-detail/Signal-2cores-twisted-pair-armoured-rs485_62193928910.html?spm=a2700.7724857.normalList.9.38b06425h3AeQA&cs=p).

[33] Muhammad M.A.S. Mahmoud, “Electrical Short Circuit Finding in MV Network using Fuzzy Clustering Techniques,” *Journal of Energy and Power Engineering, JEPE*, January 2013.

[34] Muhammad M.A.S. Mahmoud, Zafar Qurbanov, “Review of Fuzzy and ANN Fault Location Methods for

Distribution Power System in Oil and Gas Sectors, IFAC, Elsevier 2018.

[35] Ilham Marufov; Muhammad M.A.S. Mahmoud (Advisor), "Intelligent Daylight Utilization for Efficient Indoor Lighting Intensity Control", Graduation Thesis, Baku Higher Oil School, 2020.

[36] James Thompson. "Are Automated daylight control systems working as they should?", "international journal of Electrical Power & Energy Systems". Page 15–20

[37] Bruno Miguel Rodrigues Rocha. "Enhanced Networked Luminaire Controller for Sustainable Ambient Illumination", "international journal of Electrical Power & Energy Systems". Page 3–5

[38] L. Perez Lombard, J. Ortiz, and C. Pout, "A review on buildings energy consumption information," "Energy and Buildings, vol. 40, no. 3". Page 394–396

[39] B. VonNeida, D. Maniccia, A. Tweed, and M. Street, "An analysis of the energy and cost savings potential of occupancy sensors for commercial lighting systems," "Proceedings of the 2000 Annual Conference of the Illuminating Engineering Society of North America". Page 24–27

[40] C. Ehrlich, K. Papamichael, J. Lai, and K. Revzan, "A method for simulating the performance of photosensor-based lighting controls," "Energy and Buildings, vol. 34". Page 14–17

[41] J. S. Edle, A. P. Thakare, and A. M. Agarkar, "Intelligent illumination system to prevail over possible diseases due to over- and under-illumination," "International Journal of Enterprise Computing and Business Systems". Pp 40–44

[42] M. Figueiro, M. Rea, R. Stevens, and A. rea, "Daylight and Productivity - A

Possible Link to Circadian Regulation," "in Light and Human Health: EPRI/LRO 5th International Lighting Research Symposium, 2002". Page 67–73

[43] P. R. Mills, S. C. Tomkins, and L. J. M. Schlangen, "The effect of high correlated colour temperature office lighting on employee wellbeing and work performance," "Journal of Circadian Rhythms. BioMed Central, vol. 5, Jan. 2007". Page 45–48

[44] "Nabirul Islam, Kazi Tanjib Rizwan, Shamima Islam Nifa", "Smart Departmental Stores", "Dept. of Electrical & Electronic Engineering, BRAC University in partial fulfillment of the requirements for the Bachelor of Science degree in Electrical & Electronic Engineering

[45] "Talha Khan , Hassan Abbas , Shehryar Ali , Waseem Arshad ", "Design & Modeling of Self Configuring Automatic Light Control System", "University of Engineering and Technology".

[46] Muhammad M. A. S. Mahmoud, Leyla Muradkhanli, "Economical and Safe Design for Low-Traffic Long-Roads Illumination Control System by Using Image Recognition Technique", Journal of Electrical and Electronic Engineering, Vol. 8, No. 5, pp. 117–126, 2020. doi: 10.11648/j.jeee.20200805.11 <http://www.sciencepublishinggroup.com/journal/paperinfo?journalid=239&doi=10.11648/j.jeee.20200805.11>

[47] Muhammad M.A.S. Mahmoud, Leyla Muradkhanl, "Safer Design and Less Cost Operation for Low-Traffic Long-Road Illumination Using Control System Based on Pattern Recognition Technique". Intelligent Control and Automation, 11, 47–62. <https://doi.org/10.4236/ica.2020.113005>