

SIMULATION OF THE RADIANT HEAT TRANSFER PROCESS IN THE ELEMENTS OF ROASTING EQUIPMENT

Stanislav Kostenko¹, Natalia Fedak², Olga Mayak³

¹Department of Food Technologies in Restaurant Industry, Kharkiv State University of Food Technology and Trade, Kharkiv, Ukraine
dlyastasa@gmail.com

ORCID: <http://orcid.org/0000-0003-0268-8008>

²Department of Food Technologies in Restaurant Industry, Kharkiv State University of Food Technology and Trade, Kharkiv, Ukraine
fedaknv@ukr.net

ORCID: <http://orcid.org/0000-0002-7460-3213>

³Department of Processes and Equipment of Food, Hotel and Restaurant Industry named after M. I. Belyaev, Kharkiv State University of Food Technology and Trade, Kharkiv, Ukraine
omayak777@gmail.com

ORCID: <http://orcid.org/0000-0002-3059-4589>

ARTICLE INFO

Article history:

Received date 15.09.2020

Accepted date 23.10.2020

Published date 30.10.2020

Section:

Equipment and technology of food production

DOI

10.21303/2313-8416.2020.001474

KEY WORDS

infrared roasting
profiling
reflector
semi-finished meat product
steak

ABSTRACT

The object of the research is the process of radiation heat transfer, taking into account a single reflection of rays in the IR device of food production.

Investigated problem – the work is devoted to solving the problem of irregularity of radiation heat transfer during infrared roasting of food products.

Main scientific results. The inverse problem of heat transfer by radiation has been solved and a technique has been developed for determining the profiles of the ray flux reflectors for uniform irradiation of receivers of a convex section. Analytical modeling of all-round uniform irradiation of an elliptical receiver has been carried out. An experimental device with low-inertia temperature sensors for infrared roasting of semi-finished meat products has been developed, which makes it possible to use a reflector shaped according to the developed analytical technique. The verification of the created technique for determining the profiles of reflectors by means of a computer experiment using the TracePro and Mathcad software systems has been carried out.

The area of practical use of the research results: the use of an experimental device with a radiant flux reflector for roasting semi-finished meat products proves that the obtained technique for profiling reflectors of heat engineering systems is acceptable for the design of infrared equipment for food production and restaurant facilities. This technique allows simulating the profile of the radiant flux reflector depending on the shape of the receiver. Studies have shown that the use of a profiled reflector in the experimental device reduces the duration of roasting of natural portioned semi-finished beef products by 33 %.

Innovative technological product: a technique for determining the profiles of ray flux reflectors for uniform irradiation of receivers with a convex section. Device for infrared roasting of semi-finished meat products.

Scope of application of an innovative technological product. The study of an experimental device with a designed radiant flux reflector for roasting semi-finished meat products proves that the obtained technique for profiling reflectors of heat engineering systems is acceptable for the design of infrared equipment for food production and restaurant facilities. Using this approach allows to approach the solution of the problem of irregularity of irradiation of products during infrared roasting.

© The Author(s) 2020. This is an open access article under the CC BY license <http://creativecommons.org/licenses/by/4.0>.

1. Introduction

1. 1. The object of research

The object of research is the process of radiation heat transfer, taking into account a single reflection of rays in the IR device of food production.

1. 2. Problem description

One of the progressive methods of thermal processing of food products is thermal processing with infrared (hereinafter IR) radiation. The use of infrared radiation intensifies the technological processes of food production due to a significant increase in the density of the heat flux on the

surface of the product and the penetration of thermal energy into the material. The main advantage of infrared roasting is the shortening of the cooking time, which leads to a reduction in energy consumption and improves the quality of the product.

It should be noted that further intensification of IR roasting as an independent processing method has certain limitations. They are based on the fact that irregularities of IR irradiation can cause local overheating of the surface and the appearance of “burns”, which significantly impair the quality of finished products. Therefore, the main scientific and practical task in this direction is the creation of a local thermal zone at the heating object or in the working space of the technological process, minimizing heat losses for heating the environment and the surface outside the selected zone.

1. 3. Proposed solution of the problem

Scientists pay considerable attention to the use of reflective devices, with the help of which the necessary irradiation of the object is achieved [1, 2]. To obtain a directed radiation flux, reflectors of various shapes are used: spherical, parabolic, hyperbolic, elliptical, etc. [3]. However, the difficulty of using such reflectors is caused by optical aberrations and the finiteness of the radiation bodies of real sources, each surface element of which is a source of a diffuse radiation flux. In work [4], a deep analysis of the research of domestic and foreign researchers in the field of IR heating and geometric modeling of heat transfer by radiation in infrared installations during heat treatment of food products was carried out, the regularities of modeling of IR radiation in absorbing gaseous media were investigated. However, the author has not solved the problem of determining the profile of the reflector for uniform irradiation of the convex receiver. In work [5], researchers describe a combined method of processing food products with IR radiation and microwave influence, but also did not consider the problem of dissipation of thermal energy during exposure. In work [6], the authors described the computer simulation of the temperature field using induction and radiation heating, however, the resulting dependences on the determination of the temperature of the inner layers of the processed material is not correct. The authors of [7] propose an innovative solution for the development of a device for low-temperature processing of meat products by infrared radiation. A feature of the device is the possibility of using secondary heat, and coming from the working space of the device, by absorbing it by an absorbing screen. But the problem of uneven irradiation of products of various shapes has not been resolved either.

Therefore, solving the problem of irregularity of radiation heat transfer during infrared roasting of food products and determining the profile of the reflector with the subsequent design of the device is an urgent scientific problem.

2. Material and methods

The heat engineering system (**Fig. 1**) consists of a tubular radiator 1, a cylindrical reflector 2, and a heat receiver with a convex cross-sectional shape 3. A Cartesian coordinate system is connected to the system so that the Oz axis passes along the radiator, and the Ox, Oy axes are located as follows, as this is shown in the **Fig. 1**.

The following designations are used: h – distance from the axis of the emitter to the center of the receiver, m; α – half of the angle in which the rays propagate, do not hit the reflector; θ_0 – half of the angle in which the rays propagate, falling on the receiver AB directly from the emitter.

As a heat receiver, a semi-ellipse was chosen with the lengths of the major and minor semi-axes a and b , respectively, which shape is closest to the section of a portioned meat semi-finished product (beefsteak and steak). The semi-ellipse equations are compiled in relative polar coordinates using the ratios of the absolute coordinates and dimensions of the heat engineering system to the semi-ellipse semi-major axis.

The beam has only one reflection from the reflector surface. When the point of reflection M moves along the surface of the reflector from N to P towards an increase in the polar angle φ , point K of the working medium, where the reflected beam hits, monotonously move its surface from A to B towards an increase in coordinate β (**Fig. 2**).

The direct flow from the emitter falls only on the CD section, limited by those attached to the ellipse (**Fig. 1**), and the AC and BD sections remain unheated by it – only the rays reflected from the reflector fall on them. Let's introduce into the calculations the direct irradiation function, which is proportional to the irradiation density.

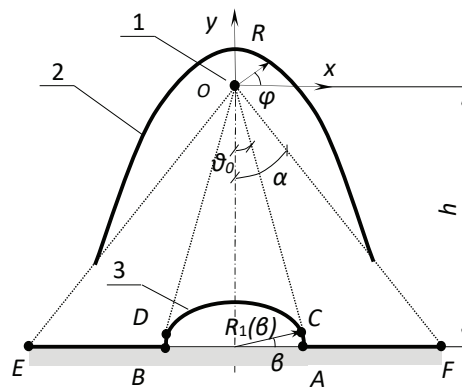

Fig. 1. Diagram of the heating system

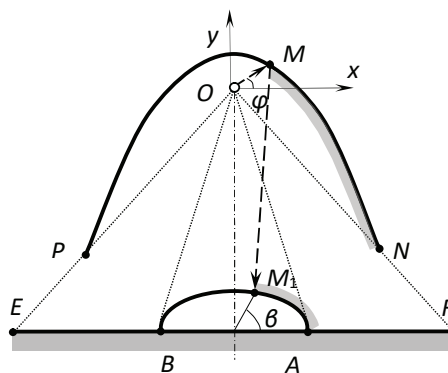

Fig. 2. Diagram of beam movement

The value of the relative density of direct irradiation is maximum on the plumb axis of the heating system, decreasing from it to points *C* and *D*, and is zero in the so-called “shadow” in sections *AC* and *BD*.

The value of the relative density of the reflected radiation is maximum in the so-called “shadow” of the heat receiver, where the direct radiation flux does not fall.

The total energy that the semi-ellipse will receive consists of the energy of the direct radiation and the energy reflected from the reflector. Taking into account the length of the semi-ellipse, this determines the equation of the relative density of the direct and reflected radiation.

Let’s compose the energy balance by equating the amount of heat per second from a radiator of a given power with the required parameters of the reflector $R(\varphi)$ and φ to the relative density of the reflected radiation, integrated along the length of the semi-ellipse with the required parameters $R_1(\beta)$ and β . From the energy balance equation, let’s obtain an equation for determining the angular coordinate of the reflector section φ .

Let’s introduce into the calculation the relative radial coordinates of the reflector and the receiver, respectively, as the ratio of $R(\varphi)$ and $R_1(\beta)$ to a , and obtain a differential equation for determining the profile of the reflector, which describes the relationship between the relative radial coordinate of the reflector and the relative angular coordinate of the receiver. The differential equation obtained in the research is solved using the Mathcad computer algebra system by the universal hybrid Adams-BDF method, which also calculates and constructs a family of reflector profiles, one of which is subject to structural implementation in accordance with the selected process of IR-roasting of meat portioned semi-finished products.

2. 2. Experimental infrared roasting device

The aim of the experimental study was to evaluate the efficiency of using a profiled reflector by physical modeling and comparing the results with computer verification of the created technique.

The experimental device implements a heat engineering system, the diagram of which is shown in **Fig. 3**. It consists of a linear radiator 1, a cylindrical reflector 2 and a heat receiver 3.

The experimental device uses one quartz emitter with a supply voltage of 220 V, a power of 720 W, and the emitter length is 250 mm. The heat wavelength is 1.2 μm , so the angles of incidence of heat rays on the reflector are equal to the angles of reflection.

The reflector is made of letter-polished aluminum, providing a reflectivity of about 90 %. Note that the size of the sheet is 275 \times 214 mm and the profile of the reflector is determined by the section of semi-finished meat products and calculation in Mathcad in accordance with the created method.

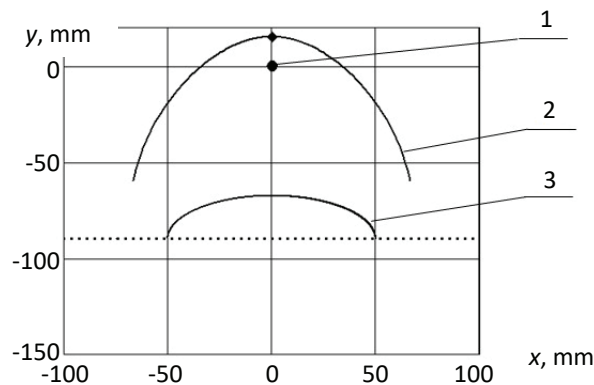

Fig. 3. Heat engineering system: 1 – emitter; 2 – reflector; 3 – receiver

A semi-ellipse with a width of 100 mm and a height of 20 ... 25 mm (for computer modeling – 22.5 mm) and a length of 200 mm is chosen as a receiver, which corresponded to the usual size and mass of steaks and splint. The distance between the centers of the emitter and the receiver is 90 mm. There should be a distance of 100 mm from the center of the product to the edge of the wire rack where it is located (**Fig. 3**).

The temperature in the working chamber is determined using nine sensors with chromel-alumel TCA thermocouples (measurement at 1100 $^{\circ}\text{C}$), which are installed on a flat frame.

2. 3. Methods of computer simulation of exposure

Existing computer programs (COSMOSWorks, TracePro, SolidWorks, etc.) fundamentally solve exclusively direct problems of irradiation, that is, determine the heat density on the surface of the receiver with a known reflector profile. In addition, the required number of beams is determined experimentally, by approximating the results to theoretical conclusions, and an incorrect number of beams can lead to significant errors.

To obtain a numerical Solution in TracePro, set the amount of heat rays emanating from the source. The computer program randomly selects points on the emitters and the direction of movement of the rays emanating from them, and automatically calculates their trajectories, but first it is necessary to set the profile of the cylindrical reflector.

The spatial distribution of the radiation flux density is modeled by calculating the trajectories of individual random rays, and the decoupling accuracy corresponds to their number. To obtain a realistic picture of the distribution of the radiant flux, it is necessary to take the number of rays at least a million.

3. Results

Let's determine the shape of the fragmented reflector of the heat engineering system for all-round uniform irradiation of the semi-elliptical receiver (with different values of the radiant flux density on the upper and lower surfaces).

Let's consider a heat engineering system (**Fig. 4**), which consists of a tubular radiator 1, a cylindrical reflector 2, and a heat receiver with a semi-elliptical shape of the upper surface and a flat lower surface 3. Let's associate the Cartesian coordinate system with the system so that the Oz axis passes along the radiator and the Ox axis, Oy positioned as shown in the **Fig. 4**.

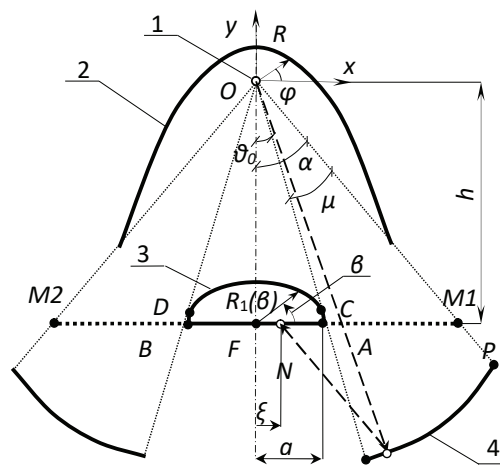

Fig. 4. Diagram of the heating system

Let's use the following notation: h – distance from the axis of the emitter to the bottom surface of the receiver, m ; α – half of the angle in which the rays propagate, do not hit the reflector; θ_0 – half of the angle in which the rays propagate, falling on the receiver AB directly from the emitter.

To designate the polar coordinates of the reflector section surface, let's use the symbols $R(m)$ and φ , for the coordinates of the upper surface of the receiver – $R_1(\beta)$ (m) and β , and at the bottom – Cartesian coordinates x and y .

The technique for determining the profile of reflector 2 was presented. Therefore, let's focus on determining the profiles of reflectors 4 (Fig. 4), that is, exactly those that will ensure uniform heating of the working fluid 3 from below. To do this, let's use a heat flux that did not fall on the receiver either directly or from the reflector. This approach to the design of heating plants will allow the processing of food from all sides with a simultaneous reduction in energy consumption.

Obviously, the heat flux density on the upper surface will be several times higher than the density on the lower one, but this ratio can be adjusted by changing the geometric parameters of the working chamber (angles α , θ_0).

Let's assume that when the point of reflection of the heat ray along the surface of the reflector moves from N to P in the direction of increasing the polar angle φ , the point where the reflected ray hits will move by its lower surface from F to A in the direction of increasing coordinate ξ (Fig. 4).

Let's design the device in such a way that the heat flux propagating in any of the corners $\mu = \alpha - \theta_0$ (Fig. 4) is reflected only from one of the fragments of the reflector and uniformly illuminates the nearest half of the lower plane of the receiver.

Let's denote by the Q the energy from one meter of the source (W/m). All the heat that falls on one linear meter of the lower half of the surface in one second is equal to

$$Q_z = \frac{Q}{2\pi} \mu. \tag{1}$$

This heat is evenly distributed with a density (W/m²)

$$q_z(\xi) = \frac{Q_z}{a} = \frac{Q}{2\pi a} \mu. \tag{2}$$

Thus, the relative density of irradiation in the absence of direct irradiation is provided by the rays reflected from below:

$$p_z(\xi) = \frac{q_z(\xi) a}{Q} = \frac{1}{2\pi} \mu. \tag{3}$$

The product section of length ξ receives the following reflected energy (W/m):

$$\int_0^\xi q_z(\xi) a \, d\xi = \int_0^\xi Q p_z(\xi) \, d\xi = Q \int_0^\xi p_z(\xi) \, d\xi. \tag{4}$$

This energy comes after reflection in the corner $\phi + \frac{\pi}{2} - \theta_0$ and is equal $\frac{Q}{2\pi} \left(\phi + \frac{\pi}{2} - \theta_0 \right)$. Equating it to dependence (4), let's obtain

$$\frac{Q}{2\pi} \left(\phi + \frac{\pi}{2} - \theta_0 \right) = Q \int_0^\xi p_z(\xi) \, d\xi. \tag{5}$$

Taking into account (3), let's obtain

$$\phi = \theta_0 - \frac{\pi}{2} + 2\pi \int_0^\xi p_z(\xi) \, d\xi = \theta_0 - \frac{\pi}{2} + \int_0^\xi \mu \, d\xi. \tag{6}$$

To determine the shape of the reflector, there is the following differential equation:

$$\frac{d\rho}{d\xi} = -\rho \frac{(\rho_1 - \rho) \cos \phi + \xi \, d\phi}{(\rho_1 + \rho) \sin \phi - \eta \, d\xi}, \tag{7}$$

where $\eta = -\chi$, $\phi = \phi(\xi)$, $\rho_1 = \sqrt{(\rho \cos \phi - \xi_z)^2 + (\rho \sin \phi - \eta)^2}$, $\rho = R/a$.

To determine the shape of the lower part of the reflector, eq. (7) was solved using Mathcad by the universal hybrid Adams-BDF method for pivelips with the ratio of the minor axis to the major axis 0.5 and such initial values ρ_0 of the relative radial coordinate ρ beyond $\phi = \theta_0 - \frac{\pi}{2}$:

$\rho_{01} = 1.25\rho_{MAX}$, $\rho_{02} = 1.5\rho_{MAX}$, where ρ_{MAX} –the relative distance from point O to point M_1 . For other variables, the following values were taken: $\chi=4$, $M_1M_2/a=6$ (Fig. 4).

Based on these results, a number of fragmented reflectors were developed, shown in Fig. 5 (the coordinate grid corresponds to the relative dimensions of the heating system). They provide a uniform heat flow on the lower plane of the heat sink.

Fig. 6 (the coordinate grid corresponds to the relative dimensions of the heat engineering system) shows a fragmented reflector for all-round uniform irradiation of a heat receiver with semi-elliptical upper and flat lower surfaces. For the upper part of the reflector, the previously described technique was used for semi-ellipse with the ratio of the minor axis to the large axis of 0.5 and such initial values ρ_0 of the relative radial coordinate ρ at $\phi = \alpha - \frac{\pi}{2}$: $\rho_{01} = 0.5\rho_{MAX}$, $\rho_{02} = 0.75\rho_{MAX}$, $\rho_{03} = \rho_{MAX}$. For the lower part, a fragmentary reflector with Fig. 5 is taken closer.

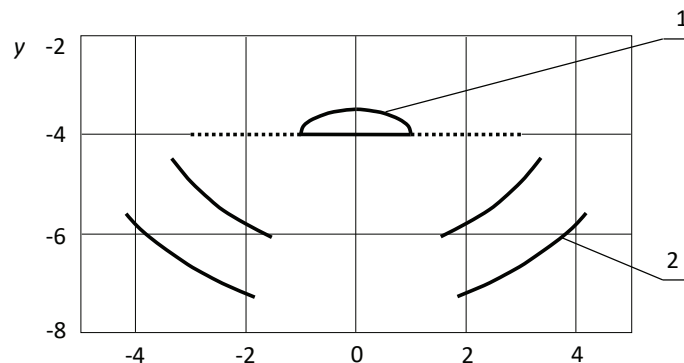

Fig. 5. Uniform irradiation of the lower plane of the semi-axis: 1 – receiver; 2 – reflector

To use the Trace Pro software package, let's take the following parameters: the emitter has a power of 720 W and a length of 1000 mm, the product has a cross-section in the form of a half ellipse 100 mm wide and 22.5 mm high, the product length is 1000 mm, which corresponds to the cross-section of a semi-finished product and the condition of considering a plane problem.

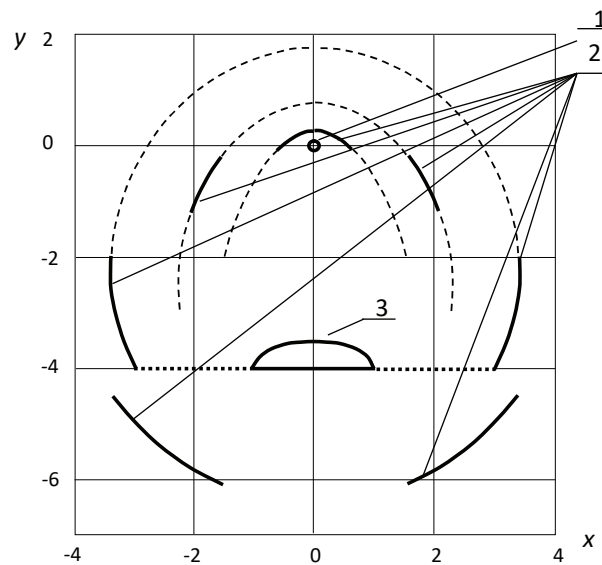

Fig. 6. All-round uniform irradiation of semi-ellipse: 1 – emitter; 2 – fragmented reflector; 3 – receiver

Let's take the shape of the reflector from previous studies. At first, 500 beams were received. The distribution of rays in the working chamber, obtained under such conditions, is shown in **Fig. 7**.

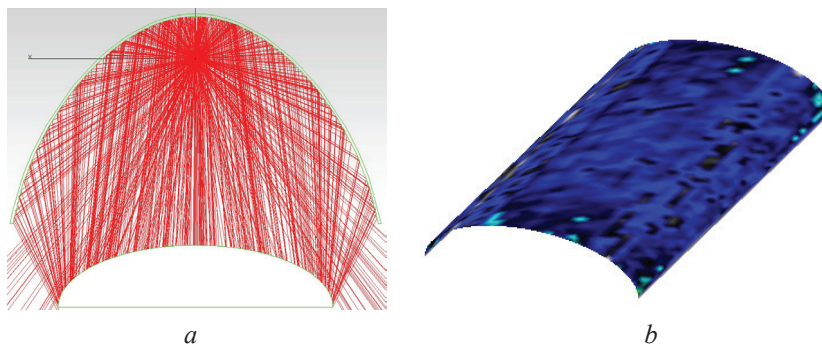

Fig. 7. Distribution of rays in the working chamber: *a* – axial projection; *b* – isometric projection

To obtain a realistic picture of the distribution of the radiant flux, it is necessary to take the number of rays at least a million. How the receiver irradiation looks like is shown in **Fig. 7, b**. A change in the irradiation intensity is presented as a change in the surface color, but even a monochrome image makes it possible to state that the heat flux density on the surface of the working fluid is a constant value (the presence of places with a slight color change in the figures is explained by the errors of the computer calculation method).

The general view of the developed device is shown in **Fig. 8**.

The uniform total irradiation of the product is provided by the polished reflector 3, the profile of which is determined by the developed method [8] and calculated for the use of the created software product in the Mathcad complex.

During roasting of semi-finished beef products in device without a reflector, the product was ready in 10 minutes, with a reflector – in 7 minutes. Roasting stopped after reaching a temperature of 75 °C inside the product was determined using a chromel-copel thermocouple.

The uniform total irradiation of the product is provided by a reflector, the profile of which, determined according to the developed method and calculated using the created software product in the Mathcad complex, is shown in **Fig. 9** (the grid is in mm).

In accordance with the dimensions of the working chamber and the selected cross-section of the product $\alpha = 0.838$; $\theta = 0.521$; $L = 118.017$ mm. For a radiator with a power of 1 kW and a length of 0.25 m, the radiant flux density is

$$q = \frac{1,000}{3.14 \cdot 118.017 \cdot 10^{-3} \cdot 1} (3.14 + 0.521 - 0.838) \times \frac{1}{0.25} \approx 30.48 \text{ kW/m}^2. \quad (8)$$

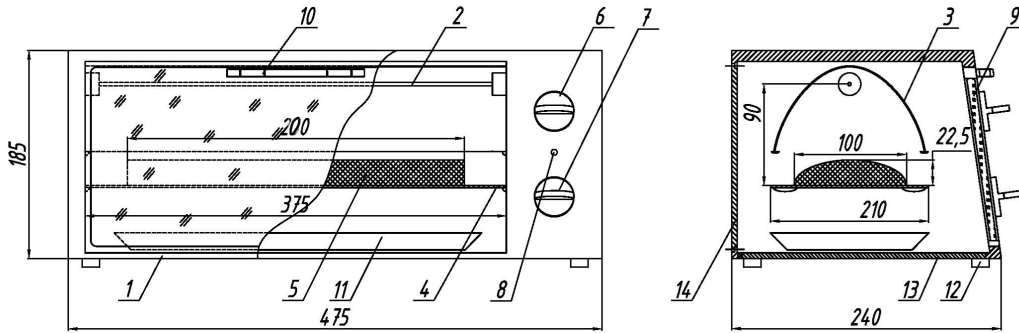

Fig. 8. General view of the ARZhM-0.07-1 device: 1 – body; 2 – emitter; 3 – reflector; 4 – lattice; 5 – product; 6 – power regulator; 7 – timer; 8 – indicator; 9 – glass doors; 10 – door handle; 11 – baking sheet; 12 – legs 13 – folding pallet; 14 – cover

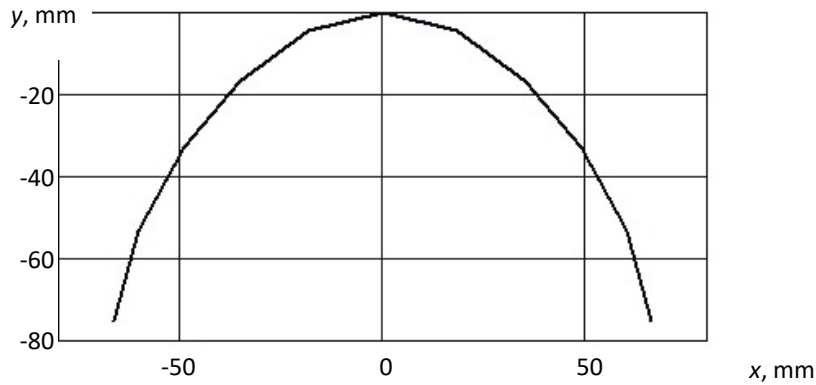

Fig. 9. Reflector profile

The analytical solution was obtained for a semi-elliptical product with a semi-major axis of 50 mm, and less – 22.5 mm, which was determined by the recommended values of a semi-finished meat product thickness of 20 ... 25 mm. That is, the ratio of the pivot axes of the receiver is $22.5/50=0.45$.

The experimental distribution of the irradiation density for a flat arrangement of thermocouples has a concave semi-elliptical character with a value in the middle of 29.83 kW/m^2 , and at the edges of 49.75 kW/m^2 . Thus, the ratio of the axes of the semi-elliptical distribution of the irradiation density is $(49.75-29.83)/50=19.92/50=0.4$. Taking into account the errors in the manufacture and installation of the reflector, this result can be considered acceptable.

Thus, comparison of the obtained results of physical and analytical modeling of infrared radiation of a convex product proves the effectiveness of the developed technique for determining the profile of the reflector of the ray flux. The device with a reflector for roasting semi-finished meat products AR-ZhM-0.07-1 provides on the surface of the product a uniform radiant flux density of about 30 kW/m^2 .

4. Discussion of research results

A heat engineering installation is considered, in which it is permissible to investigate the distribution of heat rays in accordance with the plane problem [9]. A technique has been created for determining the profiles of reflectors for uniform irradiation of a receiver with a convex section by solving the inverse problem of irradiation, that is, from the receiver to the shape of the reflector. The solution of the inverse problem allows to arrive at a rational form of the reflector. As a heat sink, a semi-ellipse was chosen with given lengths of semi-axes, which shape is closest to the section of a portioned meat semi-finished product (Fig. 3). As a result of analytical modeling, a differential equation was obtained to determine the shape of the reflector (formula 7). The

verification of the created technique for determining the profiles of reflectors was carried out by means of a computer experiment using the TracePro and Mathcad software systems, which proves its correctness [8, 10]. The developed technique for determining the profiles of reflectors was validated by a physical experiment on the use of an experimental IR roasting device (**Fig. 8**), which made it possible to evaluate the efficiency of using an analytically profiled reflector and compare the results with computer verification of the created technique, proves its acceptability for designing IR equipment for food production and restaurant facilities. When using the Mathcad software package, a software product was created to determine the shapes of reflectors, which will provide exactly the specified distribution of the radiant flux on the surface of the convex heat sink (**Fig. 7**). An industrial prototype of device with a reflector for roasting semi-finished meat products has been developed, which provides a uniform density of radiant flux on the surface of the product.

The limitation of this research is the geometry of the receiver, namely semi-ellipse, which is the closest to the shape of a semi-finished meat steak. The heat engineering system for modeling the reflector profile takes into account precisely the semi-ellipse geometry. That is, this technique is not general.

In this study, the shape of the receiver, namely the semi-ellipse, determined the profile of the simulated reflector. That is, further research involves the choice of a receiver of a different shape and, as a consequence, the calculation of a different geometry of the reflector profile.

5. Conclusions

A technique has been developed for determining the profile of a ray flux reflector during heat exchange by infrared radiation. Computer simulation of the propagation of heat rays in the working chambers of heat engineering systems using the TracePro software package proves that the obtained technique for profiling reflectors of heat engineering systems is correct.

The use of an experimental device with a radiant flux reflector for roasting semi-finished meat products proves that the obtained technique for profiling reflectors of heat engineering systems is acceptable for the design of infrared equipment for food production and restaurant facilities. The use of a profiled reflector in the device reduces the roasting period of natural portioned semi-finished beef products by 33 %. An industrial prototype of device with a reflector for infrared roasting of semi-finished meat products has been developed, which provides a uniform radiant flux density of about 30 kW/m² on the surface of the product.

References

- [1] Ramazanov, S. K., Skripnik, V. O., Molchanova, N. Iu. (2015). Modeling of dynamics of heat conductivity in the process of double-sided frying of meat on the basis of nonlinear optimization. *Technology audit and production reserves*, 3 (3), 41–47. doi: <http://doi.org/10.15587/2312-8372.2015.44167>
- [2] Tormosov, Yu. M. (2004). *Heometrychne modeliuвання ta optymizatsiia protsesu teplovoi promenevoi obrobky kharchovykh produktiv*. Kyiv, 270.
- [3] Sereda, N. I. (1999). *Heometrychne modeliuвання perebihu promeniv v eliptychnykh ta parabolichnykh vidbyvalnykh systemakh*. Kyiv: KNUBA, 174.
- [4] Tormosov, Yu. M., Saienko, S. Yu. (2018). *Heometrychne modeliuвання reflektoriv infrachervonykh aparativ kharchovoi promyslovosti*. Kharkiv, 123.
- [5] Aboud, S. A., Altemimi, A. B., R. S. Al-Hilphy, A., Yi-Chen, L., & Cacciola, F. (2019). A Comprehensive Review on Infrared Heating Applications in Food Processing. *Molecules*, 24 (22), 4125. doi: <http://doi.org/10.3390/molecules24224125>
- [6] Dutka, V. A. (2013). *Kompiuterne modeliuвання temperaturnoho polia v protsesi spikannia karbidnykh kompozytiv pry vykorystanni induktsiinoho ta promenevoho nahrivannia*. *Sverkhтверdie materyali*, 1, 40–55.
- [7] Zahorulko, A., Zagorulko, A., Yancheva, M., Serik, M., Sabadash, S., Savchenko-Pererva, M. (2019). Development of the plant for low-temperature treatment of meat products using ir-radiation. *Eastern-European Journal of Enterprise Technologies*, 1 (11 (97)), 17–22. doi: <http://doi.org/10.15587/1729-4061.2019.154950>
- [8] Plevako, V. P., Kostenko, S. M., Pedorych, I. P. (2013). Check of the methodology for determination of profile of reflector of beam stream. *Eastern-European Journal of Enterprise Technologies*, 6 (5 (66)), 42–45. Available at: <http://journals.uran.ua/eejet/article/view/18735>
- [9] Plevako, V. P., Saienko, S. Yu. (2008). Dovedennia dotsilnosti rozrakhunku teplotekhnichnykh system u plaskii postanovtsi. *Heometrychne ta kompiuterne modeliuвання*, 21, 20–29.
- [10] Saienko, S. Yu., Plevako, V. P. (2009). Modeliuвання rozpovsiudzhennia teplovykh promeniv u ICh-aparatakh kharchovoi promyslovosti zasobamy TracePro. *Heometrychne ta kompiuterne modeliuвання*, 25, 57–62.