

# Importance of Tool Configuration in Incremental Sheet Metal Forming of Difficult to Form Materials using Electro-Plasticity

Javed Asghar, Reddy, N. V.

**Abstract**— Titanium alloys possess low formability and high flows stresses and are difficult to form without using thermal aid to reduce the flow stress. It has been observed that high density electric pulse aide plastic deformation through electron-dislocation interaction and this phenomenon is termed as electro-plasticity where the reduction in flow stress is not due to resistive heating. Present work makes use of high density DC pulses to deform a Ti alloy using incremental sheet metal forming (ISMF) to emphasize the importance of tool configuration to minimize the resistive heating. Results indicate that the tool configuration plays a significant role to reduce the effect of resistive heating and to enhance effectiveness of electro-plastic effect.

**Index Terms**—Electro-plasticity, Incremental Sheet Forming, Titanium Alloys, Tool Configuration.

## I INTRODUCTION

Titanium and its alloys are used in aerospace, chemical engineering, biomedical etc. applications due to their high specific strength and excellent corrosion resistance. The use of titanium and its alloys in sheet metal applications is however constrained due to their limited formability at room temperature. In addition, due to high flow stresses, the forming forces are quite high which results in excessive forming loads. To overcome low formability, titanium sheets are formed at high temperatures as in the process of hot forming or Super Plastic Forming (SPF) which is characterized by very low strain rates ( $10^{-1}$  to  $10^{-4}$  s $^{-1}$ ) and very high temperatures (around 900-930°C) [1]. Low strain rates results in very long cycle times and high working temperatures demands for special heat resistant materials for dies, auxiliary equipment and additional space and additional cleaning processes to remove oxide layers which form at temperature of around 550 °C [1]. In the recent past, apart from thermal working, researchers have envisaged a

new method of forming by stimulating the plastic deformation of metal through pulses of high peak current density [2-6]. It has been demonstrated that there is a flow stress reduction with increase in formability by allowing very high density DC pulses to pass through test specimen during loading. The current pulses are said to stimulate the electron and phonon sub-systems resulting in a phenomenon called "electro-plastic effect" [7]. A part of the energy given through current pulses results in joule heating and rest gives rise to electron-dislocation interaction. Dislocation dynamics induced by electron wind and de-pinning of dislocations from obstacles due to magnetic field induced by electric current results in flow stress drop and increase in formability. Recently, Jones *et al.* [8] studied the effect Constant as well as Non constant current density on deformation behaviour of Ti-6Al-4V and 304 Stainless steel. They concluded that a constant current density can significantly reduce the flow stresses of material as compared to non constant current density. Significant reduction in material flow stresses have been reported when current densities of 10-50A/mm $^2$  are used. Regions of strain weakening were significantly notable in current density of 40-50 A/mm $^2$ . They also reported that for low values of current densities (10-30A/mm $^2$ ) test specimen fractured at strain value of approximately 0.3 whereas, maximum strain value of 0.74 have been achieved when deformation is carried out at high current density of around 40-50A/mm $^2$ . Fan *et al.* [9] used electric resistive heating to heat Ti-6Al-4V sheets to raise the temperature to the level of 500°C to 600°C and formed using Single Point Incremental Forming (SPIF). At those temperatures, the formability increases but affects the material quality.

Present work is an attempt to study the influence of high current density DC pulses during incremental forming of difficult to form sheet metals such as Ti alloys. Emphasis of this work is on enhancing the deformation due to electro-plasticity effect rather than the thermal effect. In this regard, effect of tool configuration on effectiveness of electro-plastic effect has also been studied.

## II EXPERIMENTAL SET-UP

Fig 1 shows the schematic of the experimental set-up used in the present study. Metallic sheet was clamped in a fixture. To preclude the current flow to the machine tool, metal blank is sandwiched between two insulating sheets and are clamped peripherally in the fixture. Clamping holes are

Manuscript received March 18, 2013; revised April 09, 2013. This work was supported in part by DRDO, Delhi.

Javed Asghar was with Indian Institute of Technology Kanpur, Kanpur, India, 208016 on study leave from Hindustan Aeronautics Limited, Transport Aircraft Division, Kanpur, India, 208007. He is now with Hindustan Aeronautics Limited, Transport Aircraft Division, Kanpur, India, 208007 (e-mail: javedraj@gmail.com).

N.V.Reddy is with Indian Institute of Technology Hyderabad, Hyderabad, India (phone: +914023017084; e-mail: nvr@iith.ac.in).

also insulated.

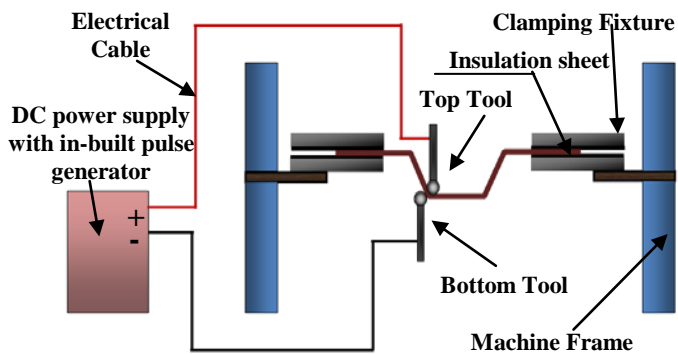

Fig 1: Schematic of experimental set-up used for Incremental Electro-plastic deformation

Photograph of actual set-up used for carrying out the present work is shown in Fig 5. Portion labelled ‘A’ shows a dc power supply with an in-built pulse generator and an oscilloscope to read pulse details. Top and bottom tools are shown as ‘B’ and ‘C’ respectively. The top tool has a provision for mounting a button load cell and it is given an excitation voltage of 10V through excitation setup shown as ‘D’. The output of load cell is recorded through a data acquisition system (shown as ‘E’) and LabView is used for the same. Temperature at tool-sheet interface during SPIF is measured by a handheld Infrared thermometer (550 °C, resolution 0.1°C and accuracy ±2°C).

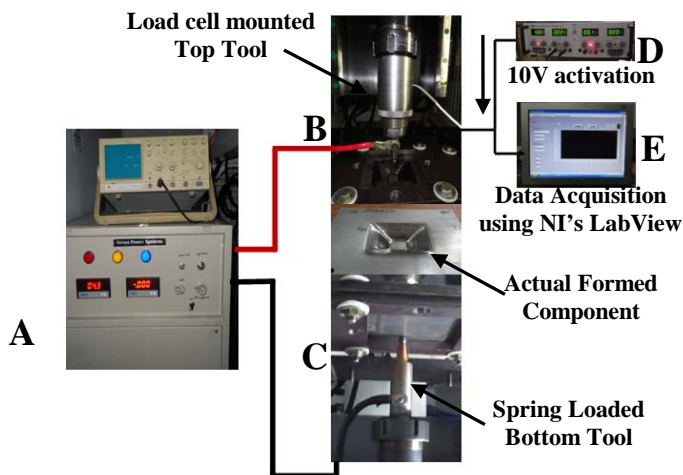

Fig 2: Actual experimental set-up used in the present study

### III METHODOLOGY

The preliminary experiments are carried out by forming truncated pyramidal component having 30 degree wall angle (shown in Fig 3) using SPIF to see the evidence of reduction in flow stress and enhancement in formability of Ti alloy sheet with the application of high density DC current pulses (at three current levels of 0, 80 and 140 amperes). The pulse ON time is chosen as 3 milliseconds for each experiment and axial force experienced by the top tool during SPIF is recorded. To maintain high peak current density and low Joule heating (resistive), tool configuration (normal) shown in Fig 4 is used throughout the deformation. In normal tool

configuration, top tool and bottom tool lie along the normal to the component at a given location. It can also be clearly seen from Fig 4, the length of current carrying element equals to the instantaneous sheet thickness given by sine law [10] i.e.

$$t = t_0 * \sin(90-\alpha)$$

where,  $t$  is instantaneous sheet thickness,  $t_0$  is initial sheet thickness and  $\alpha$  is component wall angle.



Fig 3: Truncated pyramid shaped component

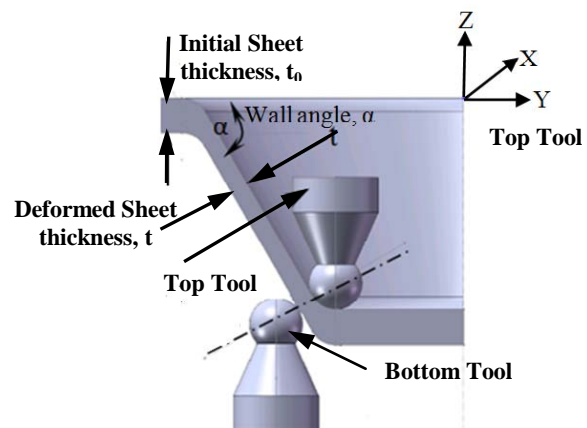

Fig 4: Normal tool configuration

### IV TOOL PATH GENERATION

Tool path necessary for both the tools under normal configuration to form the components is generated using the methodologies developed at IIT Kanpur [11]. In this method of tool path generation, the target part (Fig 5(a)) is virtually sliced by a number of parallel infinite planes at a predefined spacing called incremental depth. Each intersection of plane with the CAD model gives a closed loop and in this process a number of closed loops each separated by a distance of chosen incremental depth is obtained. Once the closed loops are obtained, spiral tool path is generated using interpolation [12]. First, top tool path is generated and then the bottom tool-path is generated by considering the instantaneous sheet thickness (using sine law), and local geometry. Tool paths generated ensure synchronized motion of both the tools.

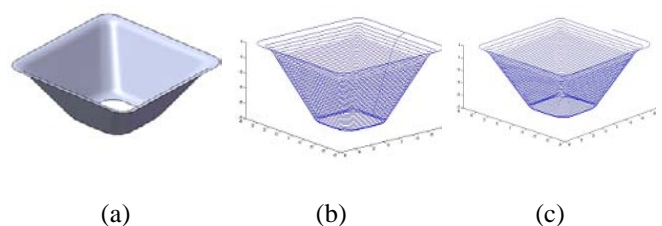

Fig 5: (a) CAD Model (b) Contour Tool path (c) Helical Tool path

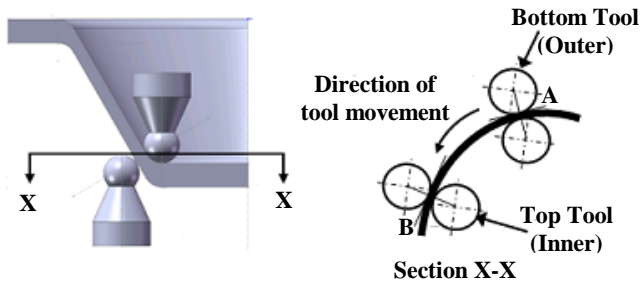

Fig 6: Schematic depiction of synchronization of top and bottom tool during forming

### V RESULTS AND DISCUSSION

The photograph given in Fig 7 shows unclamped test specimens made of a Titanium alloy. It is clearly evident from Fig 7(a) that specimen formed at room temperature without any assistance of electro-pulsing is highly distorted. This distortion in shape may be attributed to the residual stresses associated with forming of titanium at room temperature. The same part is then formed with the aid of high density current pulses. Fig 7(b) & (c) shows the formed components at current values of 80A and 140A respectively at pulse ON time of 3ms.



Fig 7: Pictures of formed components at no current, 80 amperes current and 140amperes current

Fig 8(a) shows the averaged force data during SPIF at three different current conditions. It is evident from Fig 8 that for a 30 degree wall angle component, axial force is continuously increasing when no electro-pulsing is used and has peaked to approximately 1200N. Whereas, force values are slightly less at 80 amps current and 3ms ON time is allowed to pass through material. However, a significant drop in force can be observed when 140 amps current with 3ms ON time is allowed to pass through material undergoing incremental deformation. To appreciate the result, a force plot obtained during deformation of Al5052 T0 sheet of 0.9 mm thickness without an electrical aid is also placed at Fig 8(b). It can be envisaged from both the figures that load experienced by forming tool while deforming a Titanium alloy at current value of 140 amps and that experienced while deforming Al 5052 T0 material are comparable. It is to be noted that the yield strength of Titanium alloy is almost one order higher than that of Al5052 T0.

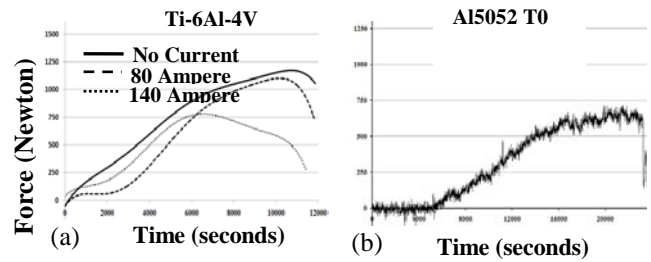

Fig 8: (a) Load measurement for 30 degree truncated pyramid of Titanium alloy (frequency: 55 Hz, On-time: 3ms, Max. temp: around 47° C with 140amps current) (b) Load curve for 30 degree truncated pyramid of Al5052T0 without electro-pulsing

Table I: Comparison of properties of Titanium alloy and Al5052 T0

Material	Yield Strength MPa	Tensile Strength MPa	% Elongation
Al5052 T0	90MPa	170-215	14-20
Ti alloy	800-1100	900-1200	13-16

Reduction in axial force at 140 amps current as compared to no current deformation is almost 35%. It is worth mentioning that the maximum temperature recorded at tool-sheet interface is only around 47 °C at 140 amps current indicating insignificant Joule heating and the corresponding flow stress reduction due to resistive heating.

To further study the effect of electro-plasticity on the force reduction during electro-pulse assisted incremental forming pyramidal component with higher wall angle ( $\alpha=45^\circ$ ) is formed. Under plane strain condition, equivalent strain for a 45 degree component is around 0.40. Successful forming of higher wall angled component will further substantiate the claim that electro-plasticity enhances formability using the same conditions used at lower wall angle.

When the experiment was performed with 80 amps current, component cracked after reaching a depth of 12 mm (Fig 9) and it got repeated in all the three trials. The same component is formed using higher current value (140 amps) but the result remains the same and failed almost at the same depth. Here, the maximum temperature raise is recorded as 180°C.

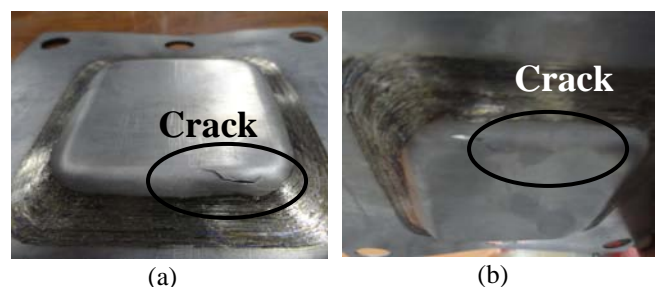

Fig 9: Picture of failed 45° pyramidal component and resulted crack

When the process is studied critically to find out the cause

of such crack development, it was realized that due to the high spring-back of Ti alloy the normal tool configuration of the tool path that ensures the minimum distance between the two tools gets disturbed. Fig 10 shows that when the normal tool configuration get disturbed due to spring-back, bottom tool (which is spring loaded) moves up in order to maintain the contact. Due to the upward movement of bottom tool, the length of current carrying element increases and it results in higher electrical resistance and decrease in current density. Due to the increase in electrical resistance and decrease in current density the component of thermal energy would have increased and component of electro-plasticity decreased resulting in crack. Increase in thermal energy was evident from the measured tool-sheet interface temperature which in this case reached upto 180°C.

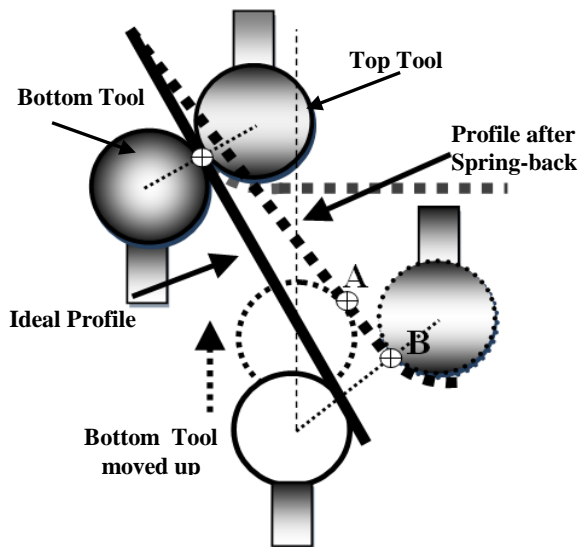

Fig 10: Effect of spring back on normal tool configuration

Even though the thermal effect has increased due to this tool configuration disturbance, the same has not been translated into enhanced formability as the successful thermal deformation of Ti alloy temperature shall be around 480°C-650°C [1].

Fig 11 shows the force data for 45° pyramidal component failed during forming after a depth or around 12 mm. It can be seen from the Fig that for 80amps as well as for 140 amps current there is no significant change in force value.

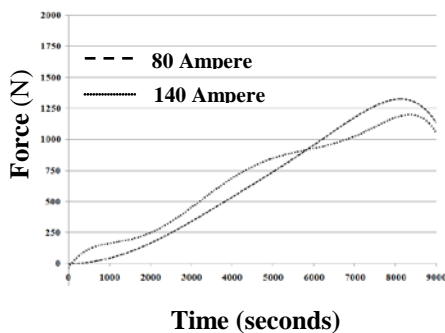

Fig 11: Force data plot for 45° pyramidal component failed after approx. 12 mm depth

To enhance the electro-plasticity effect during the forming of 45 degree component, an alternative tool path/configuration strategy that reduces the current carrying element length is proposed and tested. But one can, predict the spring back and accordingly generate the tool path to maintain the normal condition as well but spring-back prediction requires electro-plastic incremental deformation analysis using FEA that takes lot computational resources and the work in this direction is in progress. In the present strategy, initial part of component upto a certain predefined depth is formed using normal tool configuration (Fig 4) and the later part is formed using aligned tool configuration shown in Fig 12. In this way even after spring back current density as well as electrical resistance will remain constant because at any instance the length of current carrying element remains close to initial sheet thickness 't<sub>0</sub>'. Fig 13 shows the combination of normal and aligned tool configurations used for forming the higher angle component (45 degree).

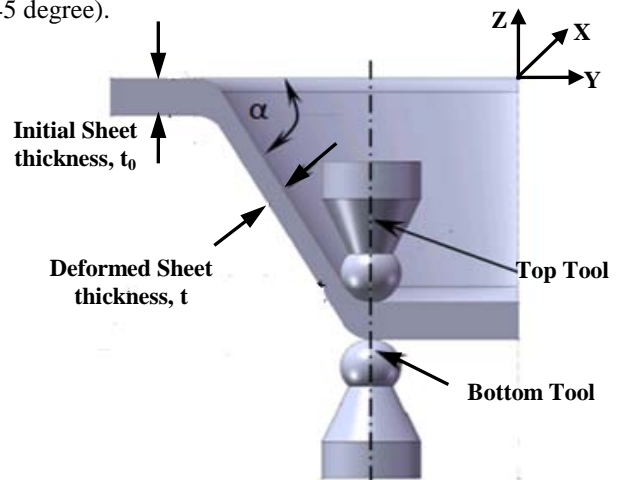

Fig 12: Align Tool Configuration

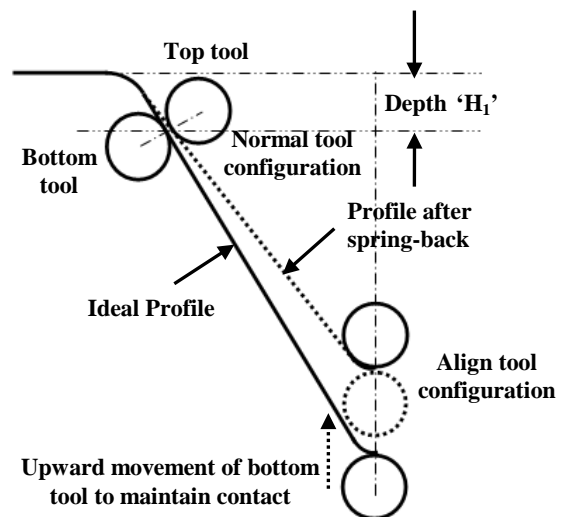

Fig 13: Mixed tool configuration

Combination of normal (upto 6.35 mm depth, equal to that of top fillet radius) and aligned tool configurations is used to form pyramidal component with wall angle  $\alpha=45$  degree and it resulted in successful component with a depth of 25mm at 80 and 140 amps. Fig 14(a) shows the formed component and Fig 14(b) shows the force variation at three current values. Maximum temperature recorded is only 88°C

for 140 amps current. Note that when component fractured at a depth of 12mm without using DC pulse aid force has reached around 1300N. This ascertains the importance of tool path by reducing the resistive heating and in enhancing the electro-plasticity effect that increases the formability. Further work is in progress.

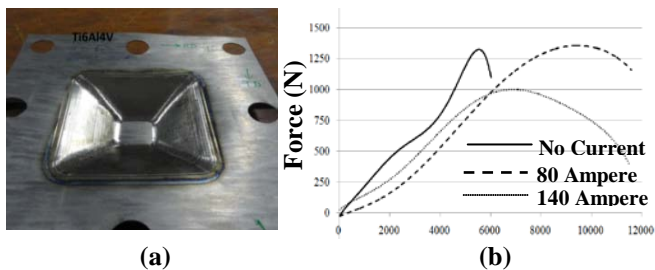

Fig 14: (a) Actual picture of 45° pyramidal component formed at 140 ampere current (b) Force data for 45° pyramidal component at 0, 80 and 140 ampere current

## VI CONCLUSIONS

Titanium alloy, which have high yield strength and low formability at low temperatures and which can only be formed at high temperatures has been successfully formed by employing a high density current pulses to flow through deformation zone in incremental sheet forming. Tool configuration during incremental forming of difficult to form alloys with DC pulse aid has to ensure that the zone of current carrying is as minimal as possible to enhance the formability due to electro-plasticity.

## REFERENCES

- [1] C. Leyens and M. Peters "Titanium and Titanium Alloys: Fundamentals and Applications," WILEY-VCH Verlag GmbH & Co. KGaA, Weinheim, 2003, ch. 1 and ch. 10.
- [2] O.A. Troitskii, "Electroplastic deformation of Metal," ProblemyProchnosti, No. 12, pp. 88-93, Dec 1976.
- [3] A.A. Kopanev, "The nature of the electroplastic effect in metals," ProblemyProchnosti, No. 1, pp 47-51, January 1991.
- [4] C.D. Ross, T.J. Kronenberger, J.T. Roth, "Effect of dc on the formability of Ti-6Al-4V," Journal of Engineering Materials and Technology, Vol. 131, July 2009.
- [5] M.I. Molotskii, "Theoretical basis for electro and magneto-plasticity," Material Science and Engg., A287, 248-258, 2000.
- [6] N. E. Kir'yanchev, O. A. Troitskii, S. A. Klevtsov, "Electroplastic deformation of metals (review)," ProblemyProchnosti, No. 5, pp. 101-105, 121, May, 1983.
- [7] A.F. Sprecher, S.L. Mannan, H. Conrad, "On the mechanisms for the electroplastic effect in metals," Acta Metall., vol. 34, no. 7, pp 1145-1162, 1986.
- [8] J. J. Jones, L. Mears, "Constant current density compression behaviour of 304 Stainless Steel and Ti-6Al-4V during Electrically-Assisted Forming," Proceedings of the ASME 2011 International Manufacturing Science and Engineering Conference MSEC 2011, June 13-17, 2011, Corvallis, Oregon, USA.
- [9] G. Fan, L. Gao, G. Hussain, Z. Wu, "Electric Hot Incremental Forming: A novel technique," International Journal of Machine Tools & Manufacture, 48, 1688-1692, 2008.
- [10] J. Jeswiet, F. Micari, G. Hirt, A. Bramley, J. Dufloy, J. Allwood, "Asymmetric single point incremental forming of sheet metal," Annals of the CIRP, 54(2), pp. 623-649, 2005.
- [11] M. Koganti, "Geometrical accuracy and complexity using double sided incremental forming," M. Tech. thesis, Dept. Of Mech. Eng., Indian Institute of Technology Kanpur, Kanpur, India, 2011.
- [12] R. Malhotra, N. V. Reddy, J. Cao, "Automatic 3D spiral toolpath generation for single point incremental forming," ASME Journal of Manufacturing Science and Engineering, 132(6), pp. 061003-1-