



EXAMINING MEDIATING EFFECT OF MOTIVATION ON EMPLOYEES' PRODUCTIVITY IN BANGLADESHI SATELLITE TELEVISION CHANNELS

Md. Al Amin Khan¹ⁱ,
Arun Kumar Tarofder²,
S. M. Ferdous Azam²

¹Postgraduate Centre (PGC),
Faculty of Business Management
and Professional Studies (FBMP),
Management and Science University,
Malaysia

²Faculty of Business Management,
and Professional Studies (FBMP),
Management and Science University,
Malaysia

Abstract:

Purpose: The motivation behind this investigation is to assess the effect of motivation on employee's productivity with regards to satellite TV station in Bangladesh. Two motivation factors were recognized based on exploratory factor analysis specifically economic factors and organizational factors also. Two dimensions in economic factors, such as, reward, remuneration and another three dimensions, such as, job stability, work condition and occupation training were found in organizational factors accordingly. Employees productivity is also analyzed here the outcome of employees.

Design/methodology/approach: Factor investigation was utilized to sum up an enormous number of motivations attributes to recognize the vital elements that sway on employee productivity. Reliability tests based on Cronbach's alpha and rectified thing complete relationship coefficients was utilized to test the internal consistency of survey responses. ANOVA tests were in this way used to test for differences in respondent's impression of this components as per chose demographics. Conclusively, a multiple regression model investigation was led to look at the connection's motivation and employee productivity as well.

Findings: Result directed that economic factors and organizational factors positively affected employee motivation and afterward it is moved to productivity in like manner. It is likewise discovered that motivation really function as a mediator.

Originality/Value: This examination has caused to notice the significance of the connections between employee motivation and employee's productivity with

ⁱ Correspondence: email alamin.mkt@gmail.com

regards to satellite TV station in Bangladesh. The discoveries have noteworthy consequences for researcher specially satellite TV station setting. In spite of the presence of exploration on the between connections among motivation and employee productivity in different orders, there are not many talked about in satellite TV context research.

Keywords: motivation, organizational factors, economic factors, employee productivity, satellite television channel

1. Introduction

Satellite television channel is extremely ground-breaking medium in Bangladesh and everywhere throughout the world too. It is a piece of day by day life for each individual for getting the information and diversion too. It has changed the whole media industry of Bangladesh within a decade (Anis, 2009). In Bangladesh, there are 30 satellite TV stations are working, and very nearly 9000 individuals are working in this industry. ATN Bangla is the first satellite TV station in the nation. Also, Dr. Mahfuzur Rahman was the maker of this dynamic industry. There are not many explores are made in this industry. That is the reason this article will assist with presenting the particular persuasive components for this company's employees that will mirror their efficiency also (Islam, 2019).

In a satellite TV station, it is an intense issue that employees are not getting their pay perfect time, for their skill advancement there are not many training courses of action offered as it were. From human resource division, it isn't appropriately assessed and giving rewards in like manner. Another enormous issue is job security also. It isn't just for their passionate and even physical part too. An empowering workplace continually moving employees work satisfaction, particularly in human services industry in light of, that industry work 24 hours. Essentially, a TV channel is likewise working 24 hours, with the goal that individuals in this industry by turn working 24 hours. Both of physical and passionate abutting they image of work situation, employee's impartiality, great collaborator relationship lastly the boss inviting demeanor with others (Akinwale, 2019).

In the current world, the leader alongside a management body ought to uncover inventiveness. They need to know that how to stimulus their workers. They need to consider that human power is the significant resource of any organization. It is an establishment of any company. In this article, there are numerous persuasive elements are talked about alongside a motivational concept. Employees of any organization who are motivated. Their profitable conduct will be improved naturally. It has another positive reflection. Because of it, employees will attempt to give their best consistently. Employees work tenure will be additionally longstanding than others one who are demotivated. Moreover, the idea of inspiration for satellite stations employees has portrayed as a dynamic supposition that each individual worker gains from their work (Ezaja et al., 2010).

In a satellite TV station working condition assumes an extremely crucial job. It isn't just for their passionate and even physical part too. In the literature earlier, Employee motivation demonstrates to the degree of confirmation and dynamism, just as the innovativeness of an individual bring to their works. Without a doubt, each organization give a lot of attention to identify the strategies that can be used human resource unit to build the performance level of their representatives (Forson, 2012).

The private channels are mainly owned by the capitalist whose fundamental premium is to pick up and expand income from advertising. In a private channel, no other source is here for money creating. The principle conqueror of these satellite stations, sales and marketing representatives who need to build up their abilities by giving training and even compensation in the wake of assessing their activity execution. Their inspiration is critical to improve their productivity as it is played a vital role for the organization. No uncertainty just stimulated representatives can accomplish their work with development (Amabile, 1983; Deci and Ryan, 2000).

Generally, Satellite TV channels are known for an overwhelming outstanding burden, long working hours and least motivated employees. It is demonstrated that motivated workers can sign to expanded efficiency. It supports to accomplish more elevated level of organizational yield also. Envision having a worker who isn't inspired grinding away, they will most likely utilize the time at their work area utilizing web for individual delight or in any event, searching for another activity (Gayen, 2020). It is an exercise in futility and company assets. Accordingly, the objectives of this research are to examination motivational factors such as economic factors and organizational factors and finally its impact on their productivity of a satellite television channel in Bangladesh.

2. Review of Literature

There is a couple of exploration has been done to quantify the employee's productivity in a satellite TV channel in Bangladesh. Besides, it's a rising industry, thinking about the current setting in the nation regarding its development and business. However, an employee motivation in a private television channel can assumes a crucial job to keep motivate them and productive also. In this area, gives a theoretical contextual and empirical contextual likewise on motivating variables Economical and Organizational and employee productivity. It has proposed five hypotheses also.

2.1 Theoretical Contextual

2.1.1 Employee Motivation

The view of motivation originated from the word motive which clarifies the energies, necessities, needs or goal inside an individual (Chaudhary and Sharma, 2012) several meanings of motivation were seen in the previous literature.

There are numerous motivation theories describes why and how human conduct is initiated and coordinated (Seiler et al., 2012). It is significant for organization to discover the components to incitement employees to perform to their most extreme

capacity. Employees are accepted to esteem intrinsic and extrinsic rewards. Both type of remunerations contributes altogether to the degrees of representatives' inspiration to work (Herzberg et al., 1959). According to Vroom (1964), expectancy can be characterized as a transient conviction followed by a specific result. The scope of expectancy can be from zero to one. Vroom's expectancy theories likewise put emphasis on the significance of inspiration in the clarification of why individuals pick a specific activity or conduct.

Most of examination on motivation contemplates watches out for Herzbergs model of intrinsic and extrinsic factors. Islam and Ismail (2008) recognized high wages, employer stability, advancement and great working conditions as the top motivations among employees. Parsons and Broadbridge (2006) explored the job of employment attributes and correspondence comparable to work motivation and fulfillment among UK good cause shop directors. Their investigation found that chiefs show low degrees of fulfillment according to pay, work status and working conditions. Kubo and Saka (2002) reasoned that money related impetuses, human asset advancement and employment self-sufficiency go about as sparks to information laborers in the Japanese monetary industry. Al-Alawi (2005) investigated the propelling components of data innovation representatives in the Bahrain lodging industry. They found that manager's thankfulness, rewards, pay increment and reward as significant variables.

2.2 Empirical Contextual

Nazuve (1999) motivation is an ability of a person to invest incredible degree of amounts of energy to accomplish business destinations, molded by the capacity to satisfy some close to personal needs. Motivation is a significant certainty for any sort of association. It is demonstrated that motivation is a significant issue for workers preeminent performing and profitability too. Therefore, a difficult issue for organization control and propensity (Tremblay et al., 2009; van nook Broeck et al., 2013)

Regardless of how computerized an organization can accomplish high level of benefit, yet it relies upon their employee's motivation. In the event that employee is a propelled, most assuredly that employee's efficiency will be high and after that that business will be profited in like manner. Motivation consistently provides the best possible guidance to all of the organization (Adeyinka et al., 2007). Employees contribution is enormously imperative to the solid and vibrant work environment (Matthew J., 2009).

In a satellite TV station, each day is changing the innovation and the style of introduction for conveying to viewers. For this, it is required to build up their aptitude as needs be to perform better. Earlier writing demonstrated that training is an extreme complex for improving worker efficiency in light of fortifies the representative's skills most assuredly. Not just for that, training additionally improves their insight lastly persuade them to work with most elevated limit (Bhat, 2013).

Another important issue is a job stability of satellite television channel. A review was analyzed that professional stability is significant in organization by choosing of 104

representatives from the central personal office of a large state agency. Job stability was found as a crucial factor for an organization (Kuhnert and Palmer, 1991).

From business purpose of view, performance investigation is significant reality no uncertainty it is. In a satellite TV station, it is crucial issue to investigation the individual representatives' performance. Furthermore, in light of that human resource people can propose what kinds of remuneration can actualized to a person that can affect on the worker motivation and their productivity as needs be. Armstrong (2008) traces that a performance assessment additionally recognize as execution examination as an assessment of how a worker has acted so as to accomplish organizational objectives.

Lawler (2003) there are numerous organizations who have increased immense advancement by completely executed their business methodology. Around then they adjusted reward and acknowledgment programs for their representatives. For this system, human asset additionally plays the indispensable game to accomplish organization's objective. Most likely, without worker's commitment it is difficult to accomplish the business focus on whatever the organization little or enormous or even private or government too. In the event that each employee gets a similar amount, nevertheless of their own contribution to the comprehension of the undertaking, the reward really doesn't meet its motivating purpose. It ought to be for the chosen and that specific representative should feel unique from others associates. In view of the writing inspected before, the first and second hypothesis for this examination are introduced as follows:

H1: Economic Factors is emphatically identified with Employee Motivation.

H2: Organizational Factors is decidedly identified with Employee Motivation.

2.3 Employee Productivity

In a satellite television channel, employee's productivity is very vital for creating a creative and functional looks of a television channels for achieve more viewership. A motivated employee is very necessary for the channel, since any organizations success completely dependent upon the employee's creativity, efficiency and commitment to the organization as well. Without any doubt it is obvious true that employees are a human capital of any organization (Kreisman, 2002). Islam (2016) Employee productivity is a mix of capability and efficiency. In an organization, each worker will make the best decision in perfect time that likewise measures the efficiency of them.

It is a fundamental that when a worker is characteristically included their activity, presumably to state that they have a profound attitude of learning new trademark about their activity. That will improve employee's commitment alongside their productivity too (Kyndt et al., 2013)

In the spacious perspective, it is seen that workplace is imperative organizational components for best exertion of employees that straightforwardly has affected on worker's productivity. Workplace involves coworker relationship, acknowledgment for extraordinary effort, professional stability and wellbeing also (Edem et al., 2017).

Regarding the prior discussion, the third and fourth hypothesis for this examination are proposed as follows:

H3: Economical Factors is decidedly identified with Employee Productivity.

H4: Organizational Factors is emphatically identified with Employee Productivity.

2.4 Relationship between Motivation and Productivity

Amabile (1993) saw that workers efficiency relies upon their degree of motivation, the people level of motivation can be extraneously or characteristically based. It is also discovered that before motivation it can't meet the standard efficiency. Worker inspiration and representative efficiency, it is depicting an immediate relationship math. In any sorts of organization, it is seen that inspired employees consistently attempt to give superior to other people. Improved worker profitability unquestionably includes the hierarchical worth in like manner (Bogdanova and Naunivska, 2008). As to earlier conversation, the fifth hypothesis for this assessment are proposed as follows:

H5: Employee Motivation is emphatically identified with Employee Productivity.

2.5 Proposed Research Model

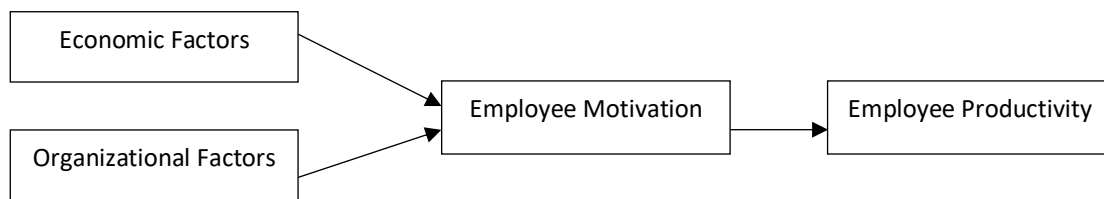

Figure 1: Proposed Research Model

The independent variables of this study we define Employee productivity and dependent variables are Economic Factors (remuneration, timely salary, rewards) and Organizational factors (training, job security, recognition, leadership). Employee Motivation is working here as a mediator.

3. Methodology

3.1 Sample

The sample for this investigation were gathered from representatives of satellite TV channels in Bangladesh. The overall number of channels are 30. These channels are utilizing around 9000 number of individuals. A sample of 140 was picked by the example intend to be oppressed for the examination. The essential information was gathered from a Likert scale poll utilizing 140 workers from satellite TV channel industry. The papers used simply primary data that was accumulated through a google form. Simple random strategy was adapted to gather information from respondents covering every satellite station. Gathered information was analyzed utilizing multi group methods to recognize

the connection between employee motivation and their productivity also. The investigation was performed utilizing the AMOS 21 programming.

Table 1: Profile of respondents

Characteristics	No of respondents	Percentage of respondents
Gender		
Male	76	54.3
Female	64	45.7
Age		
25-30 years	29	20.7
30-35 years	26	18.6
35-40 years	34	24.3
Above 40 years	51	36.4
Education		
Under graduate	9	6.4
Bachelors	87	62.1
Masters	44	31.4
Work experience		
Less than 5 years	36	25.7
5-10 years	33	23.6
More than 10 years	71	50.7

Table 1 shows that the sample size was 140 out of which 76 were male and 64 were females whose rate is 54.3% for male and 45.7 % for female. The vast majority of the representatives working in this sector are lies in the age of 35 or more which 36.4 % employees are having age of 30-35 are 18.6 % and employees old enough 25-30 are 20.7%.Most of the workers in satellite TV station are graduates having four year certification that is of 62.1 % after this present Master's qualification holders are 31.4 % and under graduates holders are 6.4 %.Employees who are working over 10 years are 50.7% of the sample employees having experience of 5-10 years are 23.6 % and the representatives who are new in this division are 25.7% methods they have under 5 years of experience.

3.2 Data Analysis Method

Factor analysis procedure was created to quantify the connection between the independent construct and dependent construct both were composite factors of second order. Firstly, the four models were tried for their suitability. The independent factors of first request class to be specific economic factors and organizational factors. Two measurements in economical components, for example, reward, compensation and another three measurements, for example, job stability, work condition and occupation training were found in organizational factors in like manner were oppressed for this analysis. As the second step every one of the four factors were joined together to build up the basic model also. In both the individual model and the structural model things were investigated and adjustment files were utilized in reaching at the model fit. During the examination applicable estimations of CMIN/df, CFI and RMSEA were considered

for model fit. In this way the last model was created and tried for the research hypothesis. In this article, utilizes a survey as a quantitative strategy. The fundamental target of this paper is to development the significant variables that motivate the employees of satellite TV station and their productivity too.

4. Results and Analysis

The individual models of measurements are economical components, such as, reward, remuneration and another three estimations, such as, work stability, work condition and occupation training were found in organizational factors in like way were set up and tried for their model fit. In the wake of rewarding the alteration files all measurements arrived at the applicable values.

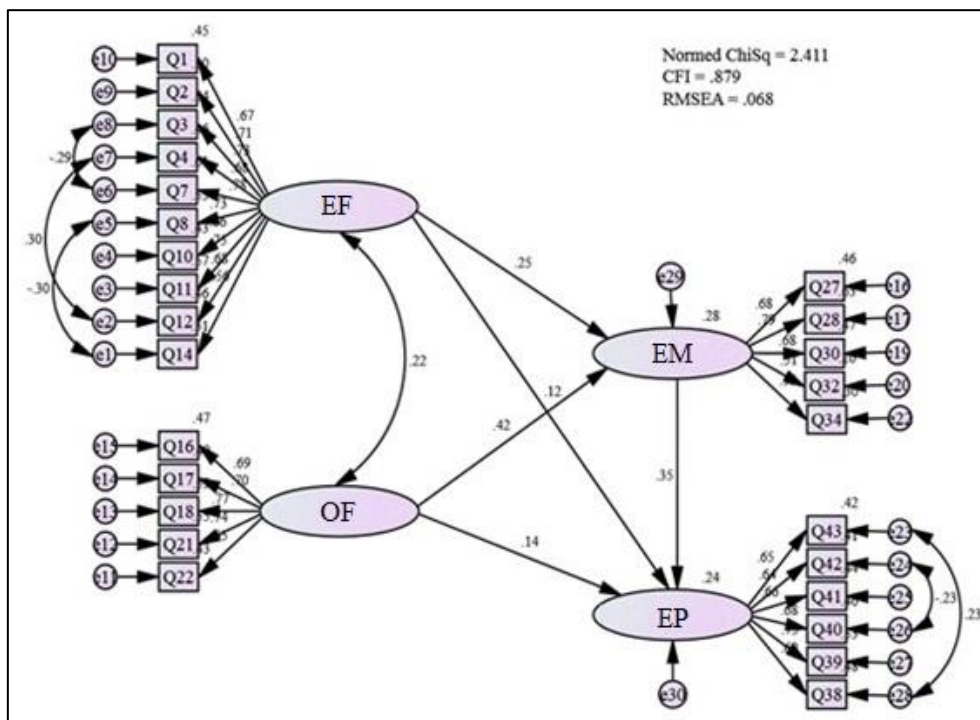

Figure 2: Modified Structural Equation Model

The model appeared in Figure 2, there were statistical inconsistencies between the observed covariance matrix of the sample and the implied covariance matrix of population. After rearranged, now the Normed chi-square (CMIN/DF) indicated a solid match for this model, with an index less than 3 (for example 2.411), supporting the consistency of the information to this model. The statistical importance of the χ^2 of the model might be because of the large sample size ($n = 140$).

In addition, the proportion of RMSEA was .068, which is below the suggested trimmed off of $RMSEA \leq .08$ for the complexity of this reconsidered model (Hair et al., 2010). In this manner, RMSEA of .068 shows absence of any noteworthy distinction between the covariance matrix of the sample and the covariance framework of population. The CFI (.879) of this model additionally show suitability of the model fit,

adding more proof to help the decency of fit of this model. The AMOS (Version 21.0) text yield didn't give any further recommendation to change this model.

Table 2: Reliability Statistics

Variable	Cronbach's Alpha	No of Items
Economic Factors	.882	5
Organisational Factors	.819	6
Employee Motivation	.827	9
Employee Productivity	.819	6
Overall	.897	26

The inside consistency of the considerable number of components were acquired by figuring the Cronbach's Alpha coefficient on the four separated elements was held by PCA. Considering the rules by specialists (Cronbach, 1951; Sekaran and Bougie, 2010), Cronbach's Alpha was utilized to assess the reliability of the extracted factors as introduced in Table 2 Every one of the four variables [Economic Factors, Organizational Factors, Employee Motivation and Employee Productivity] had great dependability lists of .882, .819, .827 and .819, individually.

The significant level of item reliability showed the things are strongly influenced by each measure construct and suggested set of things are unidimensional (Hair et al., 2009).

4.1 Hypothesis Testing

As indicated by the structural model signified to (see Figure 2), the aftereffects of testing connections between employee motivation factors such organizational and economical lastly their effect on productivity.

In this segment of the examination at last tests the model in the wake of fulfilling the necessities of reliability and validity too. The easygoing connections of the independent factor are estimated on dependent factors.

Table 3: Standardized Regression Weights: (Default model)

Variable	Relationship	Variable	Estimate
Employee Motivation	<---	Economic Factors	.250
Employee Motivation	<---	Organisational Factors	.419
Employee Productivity	<---	Employee Motivation	.350
Employee Productivity	<---	Economic Factors	.122
Employee Productivity	<---	Organisational Factors	.141
Economic Factors	<-->	Organisational Factors	.220

H1: Economic Factors is emphatically identified with Employee Motivation. As appeared in Table 3, the way coefficient between Economic Factors and Employee Motivation was .250 and measurably noteworthy. This demonstrates Economic Factors impacts Employee Productivity from satellite TV station in Bangladesh viewpoints. Therefore, H1 is accepted.

H2: Organizational Factors is decidedly identified with Employee Motivation.

As appeared in Table 3, the way coefficient between Organizational Factors and Employee Motivation was very high (.419) and factually noteworthy. This shows Organizational Factors has additionally a critical positive effect on Employee Motivation from satellite TV station in Bangladesh points of view.

In this manner, H2 is additionally accepted.

H3: Economical Factors is decidedly identified with Employee Productivity.

As appeared in Table 3, the way coefficient between Economic Factors and Employee Productivity was just .122 and factually not huge. Also, the relationship isn't measurably noteworthy from satellite TV station in Bangladesh points of view.

In this manner, H3 is rejected.

H4: Organizational Factors is emphatically identified with Employee Productivity.

As appeared in Table 3, the way coefficient between Organizational Factors and Employee Productivity was very low (.141) and measurably inconsequential. This demonstrates Organizational Factors don't have noteworthy effect on Employee Productivity in the satellite TV station in Bangladesh points of view.

Along these lines, H4 is rejected.

H5: Employee Motivation is emphatically identified with Employee Productivity.

As appeared in Table 3, the way coefficient between Employee Motivation and Employee Productivity was very high (.350) and factually noteworthy. This shows Employee Motivation has likewise a critical positive impact on Employee Productivity from satellite TV slot in Bangladesh points of view.

Therefore, H5 is accepted.

5. Conclusion

Today, employee is the most significant mainstay of any organization. What's more, no doubt it is demonstrated that their motivation lastly their output is the primary concern is the organization. It is comprehended that Motivation impacts on employee's productivity altogether. In Satellite TV channel in Bangladesh 140 samples were gathered and after investigation this information indicated unmistakably that Motivation functioned as a mediator between employee motivation and productivity. As needs be, this exploration found that economic variables, organizational components, employees' motivation that each individual affected on worker efficiency. From this examination, it shows that motivation is essential to the employees as it can energize their degree of efficiency. What's more, it is likewise significant that the management of a satellite TV channel to comprehend and know about the requirements of their employees. Moreover, the better efficiency of any workers not just rely upon them it relies upon the administration also.

6. Limitations

There are various constraints present in the current examination. Employees are progressively significant for an organization where satellite TV station is one of them extraordinarily in Bangladesh. In this research just, not many primary components are talked about as an intervening element of motivation and that chip away at productivity. And it is described only satellite television channel but so many other components that have also related to the satellite tv channel, but it is not pronounced here. however further research may test the effect of segment factors, for example, age, education, and mental impressive of employees to decide their motivation and productivity as well.

References

- Akinwale, O. E. (2019). Employee voice: speaking up in the organisation as a correlate of employee productivity in the oil and gas industry – an empirical investigation from Nigeria, *Serbian Journal of Management*, Vol. 14 No. 1, pp. 97-121.
- Amabile, T. M. (1983). *The Social Psychology of Creativity*, Springer-Verlag, New York.
- Armstrong M. (2008). *Armstrong's Handbook of Strategic Human Resource Management*. London, Kogan Page.
- Bhat, Z. H. (2013). Impact of training on employee performance: A study of retail banking sector in India. *Indian Journal of Applied Research*, 3(6), 292–293.
- Bogdanova, A., Enfors, H., & Naumovska, S. (2008). Work environment stressors - The link between employees' well-being and job performance? (Bachelor dissertation, Jönköping University, 2008).
- Chang, I. C., Li, Y. C., Hung, W. F. and Hwang, H. G. (2005). An empirical study on the impact of quality antecedents on taxpayer's acceptance of internet tax-filing systems, *Government Information Quarterly*, Vol. 32 No. 4, pp. 389-410.
- Chaudhary, N., & Sharma, B. (2012). Impact of employee motivation on performance (productivity) in private organization. *International Journal of Business Trends and Technology*, 2(4), 29–35.
- Deci, E. L. and Ryan, R. M. (2000). The 'what' and 'why' of goal pursuits: human needs and the self- determination of behavior", *Psychological Inquiry*, Vol. 11, pp. 227-268.
- Edem, M. J., Akpan, E. U. and Pepple, N. M. (2017). Impact of workplace environment on health workers, *Occupational Medicine and Health Affairs*, Vol. 5 No. 2, pp. 1-5.
- Ezeja, E. B., Azodo, C. C., Ehizele, A. O., Ehigiator, O. and Oboro, H. O. (2010). Assessment of job satisfaction and working conditions of Nigerian oral health workers, *International Journal of Biomedical and Health Sciences*, Vol. 6 No. 3, pp. 143-150.
- Forson, J. E. M. (2012). *Impact of motivation on the productivity of employees at GT Bank Ghana* (Doctoral dissertation). Meghalaya: University of Science and Technology.

- Fu, J. R., Chao, W. P. and Farn, C. K. (2004). Determinants of taxpayer's adoption of electronic filing methods in Taiwan: an exploratory study, *Government Information Quarterly*, Vol. 14 No. 3, pp. 313-324.
- Gayen, K. (2020, January 22). (Uncertain) Future of Journalism in Bangladesh. Retrieved July 08, 2020, from <https://www.thedailystar.net/star-weekend/news/uncertain-future-journalism-bangladesh-1833094>
- Hair, J. F., Black, W. C., Baban, B. J. and Anderson, R.E. (2009). *Multivariate Data Analysis*, 7th ed., Prentice Hall, Upper Saddle River, NJ.
- Herzberg, F., Mausner, B. and Syndermann, B. B. (1959). *The Motivation to Work*, John Wiley & Sons, New York, NY.
- Islam, M. (2019, September 19). All TV channels on board Bangabandhu Satellite. Retrieved July 08, 2020, from <https://www.thedailystar.net/business/news/all-tv-channels-board-bangabandhu-satellite-1802131>
- Islam, M. and Adnan, A.T.M. (2016). Improving Ready-Made Garment Productivity by Changing Worker Attitude, *European Scientific Journal*, Vol. 12 No. 4, pp. 436-444.
- Kreisman, B. J. (2002). Identification of the drivers of employee dissatisfaction and turnover. (Doctoral dissertation, University of Texas, 2002).
- Kyndt, E., Raes, E., Dochy, F. and Janssens, E. (2013). Approaches to learning at work: investigating work motivation, workload and choice independence, *Journal of Career Development*, Vol. 40, pp. 271-291.
- Lawler, E. E. (2003). *Treat people right*. San Francisco: Jossey-Bass Inc. McGraw-Hill Irwin.
- Matthew, J., Grawhich, & Barber, L. K. (2009). Are you Focusing both Employees and Organizational Outcomes. *Organizational Health Initiative at Saint Louis University*, 1-5.
- Nzuve, S. N. (1999). *Elements of organizational behavior*. Nairobi: University of Nairobi Press.
- Parsons, E. and Broadbridge, A. (2006). Job motivation and satisfaction: unpacking the key factors for charity shop managers, *Journal of Retailing and Consumer Services*, Vol. 13 No. 2, pp. 121-131.
- Rahman, Anis (2009). *A political Economy of the Emerging Television News Industry in Bangladesh*. Sage Publications. on behalf of: Association for Education in Journalism & Mass Communication. 11(2). May/2009 (Retrieved on 2/6/2014: www.eptic.com.br)
- Seiler, S., Lent, B., Pinkowska, M. and Pinazza, M. (2012). An integrated model of factors influencing project managers' motivation – findings from a swiss survey, *International Journal of Project Management*, Vol. 30 No. 1, pp. 60-72.
- Tremblay, M. A., Blanchard, C. M., Taylor, S., Pelletier, L. G. and Villeneuve, M. (2009). Work extrinsic and intrinsic motivation scale: its value for organizational psychology research, *Canadian Journal of Behavioral Sciences*, Vol. 41, pp. 213-226.

- Van den Broeck, A., Lens, W., De Witte, H. and Van Coillie, H. (2013). Unraveling the importance of the quantity and the quality of workers' motivation for well-being: a person-centered perspective, *Journal of Vocational Behavior*, Vol. 82, pp. 69-78.
- Venkatesh, V., Morris, M. G., Davis, G. B. and Davis, F. D. (2003). User acceptance of information technology: toward a unified view, *MIS Quarterly*, Vol. 27 No. 3, pp. 425-478.
- Vroom, V. H. (1964). *Work and Motivation*, John Wiley and Sons, New York, NY.
- Wang, Y. S. (2003). The adoption of electronic tax filing systems: an empirical study, *Government Information Quarterly*, Vol. 20 No. 4, pp. 333-352.

Creative Commons licensing terms

Authors will retain copyright to their published articles agreeing that a Creative Commons Attribution 4.0 International License (CC BY 4.0) terms will be applied to their work. Under the terms of this license, no permission is required from the author(s) or publisher for members of the community to copy, distribute, transmit or adapt the article content, providing a proper, prominent and unambiguous attribution to the authors in a manner that makes clear that the materials are being reused under permission of a Creative Commons License. Views, opinions and conclusions expressed in this research article are views, opinions and conclusions of the author(s). Open Access Publishing Group and European Journal of Management and Marketing Studies shall not be responsible or answerable for any loss, damage or liability caused in relation to/arising out of conflict of interests, copyright violations and inappropriate or inaccurate use of any kind content related or integrated on the research work. All the published works are meeting the Open Access Publishing requirements and can be freely accessed, shared, modified, distributed and used in educational, commercial and non-commercial purposes under a [Creative Commons Attribution 4.0 International License \(CC BY 4.0\)](https://creativecommons.org/licenses/by/4.0/).