



JRC SCIENTIFIC AND POLICY REPORTS

EUROCODE 2: BACKGROUND & APPLICATIONS **DESIGN OF CONCRETE BUILDINGS**

Worked examples

Authors:

F.Biasioli, G.Mancini, M.Just, M.Curbach, J.Walraven,
S.Gmainer, J.Arrieta, R.Frank, C.Morin, F.Robert

Editors:

F.Biasioli, M.Poljanšek, B.Nikolova, S.Dimova, A.Pinto

2014



Report EUR 26566 EN

European Commission
Joint Research Centre
Institute for the Protection and Security of the Citizen

Contact information

Address: Joint Research Centre, Via Enrico Fermi 2749, TP 480, 21027 Ispra (VA), Italy
E-mail: eurocodes@jrc.ec.europa.eu
Tel.: +39 0332 78 9989
Fax: +39 0332 78 9049

<http://ipsc.jrc.ec.europa.eu/>
<http://www.jrc.ec.europa.eu/>

Legal Notice

Neither the European Commission nor any person acting on behalf of the Commission is responsible for the use which might be made of this publication.

Europe Direct is a service to help you find answers to your questions about the European Union
Freephone number (*): 00 800 6 7 8 9 10 11

(*) Certain mobile telephone operators do not allow access to 00 800 numbers or these calls may be billed.

A great deal of additional information on the European Union is available on the Internet.
It can be accessed through the Europa server <http://europa.eu/>.

JRC89037

EUR 26566 EN

ISBN 978-92-79-36548-5

ISSN 1831-9424

doi:10.2788/35386

Luxembourg: Publications Office of the European Union, 2014

© European Union, 2014

Reproduction is authorised provided the source is acknowledged.

Printed in Italy

Contents

List of authors and editors.....	vii
Foreword.....	ix
CHAPTER 1.....	1
CONCEPTUAL AND PRELIMINARY DESIGN	
1.1 Introduction.....	3
1.2 Basic data.....	4
1.2.1. General data and preliminary overview.....	4
1.2.2. Slab geometry	6
1.3 Actions.....	9
1.3.1. Densities, self-weight, imposed loads, partial and combination factors	9
1.3.2. Wind.....	10
1.3.3. Snow load	12
1.4 Materials	12
1.4.1. Concrete.....	12
1.4.1.1 Exposure classes and concrete strength class.....	12
1.4.1.2 Exposure classes, structural classes and concrete cover	13
1.4.2. Reinforcing steel	17
1.4.2.1 Steel characteristics.....	17
1.4.2.2 Maximum bar diameters	17
1.5 Conceptual design of slabs	18
1.5.1. Slab height	18
1.5.1.1 Slenderness.....	18
1.5.1.2 Slab height determination	20
CHAPTER 2.....	23
STRUCTURAL ANALYSES	
2.1 Finite element modelling of the building.....	25
2.2 Loads, load cases and their combinations	26
2.2.1. Loads	26

2.2.2.	Load cases for dead loads	26
2.2.2.1	Load case 1 – dead load of the bearing structure.....	26
2.2.2.2	Load case 2 – dead load of the interior.....	27
2.2.2.3	Load case 3 – dead load of the facade.....	27
2.2.3.	Load cases for wind, snow and service loads 1 and 2.....	28
2.2.3.1	Load case 51	28
2.2.3.2	Load case 101	28
2.2.3.3	Load case 201	29
2.2.3.4	Load cases 202 to 206.....	29
2.2.3.5	Load cases 1326, 1336, 1356 and 1366.....	30
2.2.3.6	Load cases 10001, 10011, 10021 and 10031.....	31
2.2.3.7	Load cases 10101, 10111, 10121 and 10131.....	32
2.2.4.	Rules for the combination of load cases	32
2.3	Internal forces and moments.....	32
2.3.1.	Position of calculated internal forces and moments.....	32
2.3.1.1	Column B2	32
2.3.1.2	Shear wall B1.....	32
2.3.1.3	Frame axis 2 – beam	32
2.3.1.4	Frame axis B – beam.....	33
2.3.1.5	Punching for flat slab	33
2.3.2.	Results of structural analysis	33
2.3.2.1	Column B2 - results for ULS and SLS	33
2.3.2.2	Shear wall B1, results for ULS and SLS	36
2.3.2.3	Frame axis 2 – beam, results for ULS	38
2.3.2.4	Frame axis B – Beam, results for ULS.....	42
2.3.2.5	Punching for flat slab, results for ULS.....	47
CHAPTER 3.....	49	
LIMIT STATE DESIGN (ULS - SLS)		
3.1 Introduction.....	51	
3.1.1. Motivation.....	51	
3.1.2. Materials.....	53	
3.2 Ultimate limit state design	53	
3.2.1. Slab on beams	53	

3.2.1.1	Static model and cross section of the slab on beams.....	53
3.2.1.2	Determination of the bending reinforcement in general.....	55
3.2.1.3	Determination of the bending reinforcement for the T-beams	57
3.2.1.4	Design of beams for shear.....	59
3.2.1.5	Design of slabs supported by beams.....	64
3.2.2.	Flat slab.....	68
3.2.2.1	Loads and internal forces for the calculation of the flat slab.....	68
3.2.2.2	Determination of the bending reinforcement.....	68
3.2.2.3	Punching shear - column B2.....	70
3.2.2.4	Column B2	75
3.2.2.5	Design of shear walls.....	84
3.2.3.	Slab with embedded elements	86
3.2.3.1	Bending reinforcement - beam axis B.....	87
3.2.3.2	Bending reinforcement of the slab with embedded elements	89
3.2.3.3	Shear capacity	91
3.3	Serviceability limit states.....	92
3.3.1.	SLS deflection - general.....	92
3.3.1.1	Deflection control by calculation	92
3.3.1.2	Tabulated K values and basic ratios (l/d).....	94
3.3.1.3	Slab on beams	94
3.3.1.4	Flat slab	95
3.3.1.5	Slab with embedded elements.....	95
3.3.2.	SLS crack width - general	96
3.3.2.1	Crack width control – slab with embedded elements.....	98
CHAPTER 4.....	101	
DETAILING OF THE REINFORCEMENT		
4.1	Detailing - general.....	103
4.1.1.	Anchorage length	103
4.1.2.	Lap length	105
4.2	Detailing of structural members.....	107
4.2.1.	Detailing of footing B-2.....	107
4.2.1.1	Design of the footing.....	107
4.2.1.2	Arrangement of the reinforcement	110

4.2.2. Detailing of beams	114
4.2.2.1 Beam A2 – B2 – C2 for the case 1	115
4.2.2.2 Beam B1 – B2 – B3 for the case 3.....	118
4.2.3. Detailing of slabs.....	121
4.2.3.1 Slab AB12 for case 1	121
4.2.4. Detailing of columns.....	123
4.2.4.1 Column B2 for the case 2	124
4.2.4.2 Column B2 - case 2	125
 CHAPTER 5.....	 129
SOME GEOTECHNICAL ASPECTS OF BUILDING DESIGN (EN 1997)	
 5.1 Introduction.....	 131
5.2 Geotechnical data.....	131
5.3 Actions on the foundations	133
5.3.1. Structural and geotechnical actions	133
5.3.2. General: the three design approaches of Eurocode 7	134
5.3.2.1 Design approach 1 (DA1)	134
5.3.2.2 Design approach 2 (DA2 and DA2*).....	136
5.3.2.3 Design approach 3 (DA3)	137
5.3.2.4 Summary for DA1, DA2 and DA3 (for “fundamental” combinations) ...	137
 5.4 Column B2 - design of foundation	 138
5.4.1. Bearing capacity (ULS)	138
5.4.2. Sliding (ULS).....	139
 5.5 Comments on settlements (SLS)	 140
5.5.1. Compensated foundation.....	140
5.5.2. Calculation based on the results of Mènard pressuremeter method.....	141
5.5.3. Adjusted elastic method	141
 CHAPTER 6.....	 145
FIRE RESISTANCE ACCORDING TO EN 1992-1-2	
 6.1 Introduction.....	 147
6.2 Data concerning building.....	147

6.2.1.	Description of the building.....	147
6.2.2.	Mechanical material properties	150
6.2.2.1	General	150
6.2.2.2	Concrete	150
6.2.2.3	Reinforcing bars.....	151
6.2.3.	Materials' physical and thermal properties.....	153
6.2.3.1	Thermal strain of concrete and steel.....	153
6.2.3.2	Concrete specific heat	154
6.2.3.3	Concrete thermal conductivity.....	154
6.2.3.4	Density of concrete and reinforcing bars	154
6.2.4.	Reinforced members' sections (column, beam and slab)	155
6.2.4.1	Column B2	155
6.2.4.2	Beam in axis 2	155
6.2.4.3	Slab on beams.....	156
6.2.5.	Actions	156
6.3	Tabulated data	157
6.3.1.	Scope.....	157
6.3.2.	Column 500/52.....	158
6.3.3.	Beam 250/44	159
6.3.4.	Slab 180/36/49.....	160
6.3.5.	Summary.....	162
6.4	Simplified calculation methods.....	162
6.4.1.	Methodology.....	162
6.4.2.	Column.....	163
6.4.3.	Continuous beam	166
6.4.3.1	Mid-span	166
6.4.3.2	Internal support.....	166
6.4.3.3	End support.....	168
6.4.3.4	Summary.....	168
6.4.4.	Two-way slab	168
6.5	Advanced calculation methods.....	170
6.6	Conclusions	170

List of authors and editors

Authors

FOREWARD

Martin POLJANŠEK	<i>European Laboratory for Structural Assessment (ELSA) Institute for Protection and Security of the Citizen (IPSC) Joint Research Center (JRC), European Commission</i>
Silvia DIMOVA	<i>European Laboratory for Structural Assessment (ELSA) Institute for Protection and Security of the Citizen (IPSC) Joint Research Center (JRC), European Commission</i>
Borislava NIKOLOVA	<i>European Laboratory for Structural Assessment (ELSA) Institute for Protection and Security of the Citizen (IPSC) Joint Research Center (JRC), European Commission</i>
Artur PINTO	<i>European Laboratory for Structural Assessment (ELSA) Institute for Protection and Security of the Citizen (IPSC) Joint Research Center (JRC), European Commission</i>

CHAPTER 1 - Preliminary design of buildings

Francesco BIASIOLI	<i>Dipartimento di Ingegneria Strutturale, Edile e Geotecnica (DISEG), Politecnico di Torino, Italy</i>
Giuseppe MANCINI	<i>Dipartimento di Ingegneria Strutturale, Edile e Geotecnica (DISEG), Politecnico di Torino, Italy</i>

CHAPTER 2 - Structural analyses

Martin JUST	<i>TU Dresden, Institute for concrete structures, Germany</i>
Manfred CURBACH	<i>TU Dresden, Institute for concrete structures, Germany</i>

CHAPTER 3 - Limit state design (ULS-SLS)

Just WALRAVEN	<i>Delft University of Technology, The Netherlands</i>
Susanne GMÄINER	<i>Vienna University of Technology, Austria</i>

CHAPTER 4 - Detailing of the reinforcement

Jose ARRIETA	<i>PROES S.A., Spain</i>
--------------	--------------------------

CHAPTER 5 - Some geotechnical aspects of building design

Roger FRANK	<i>Université Paris-Est, Ecole des Ponts ParisTech, Laboratoire Navier Geotechnical team (CERMES), France</i>
-------------	---

CHAPTER 6 - Fire resistance according to EN 1992-1-2

Caroline MORIN	<i>CERIB, France</i>
Fabienne ROBERT	<i>CERIB, France</i>

Editors

Francesco BIASIOLI	<i>Dipartimento di Ingegneria Strutturale, Edile e Geotecnica (DISEG), Politecnico di Torino, Italy</i>
Martin POLJANŠEK	<i>European Laboratory for Structural Assessment (ELSA) Institute for Protection and Security of the Citizen (IPSC) Joint Research Center (JRC), European Commission</i>
Borislava NIKOLOVA	<i>European Laboratory for Structural Assessment (ELSA) Institute for Protection and Security of the Citizen (IPSC) Joint Research Center (JRC), European Commission</i>
Silvia DIMOVA	<i>European Laboratory for Structural Assessment (ELSA) Institute for Protection and Security of the Citizen (IPSC) Joint Research Center (JRC), European Commission</i>
Artur PINTO	<i>European Laboratory for Structural Assessment (ELSA) Institute for Protection and Security of the Citizen (IPSC) Joint Research Center (JRC), European Commission</i>

Foreword

The construction sector is of strategic importance to the EU as it delivers the buildings and infrastructure needed by the rest of the economy and society. It represents more than 10% of EU GDP and more than 50% of fixed capital formation. It is the largest single economic activity and it is the biggest industrial employer in Europe. The sector employs directly almost 20 million people. Construction is a key element not only for the implementation of the Single Market, but also for other construction relevant EU Policies, e.g. Sustainability, Environment and Energy, since 40-45% of Europe's energy consumption stems from buildings with a further 5-10% being used in processing and transport of construction products and components.

The EN Eurocodes are a set of European standards which provide common rules for the design of construction works, to check their strength and stability against live extreme loads such as fire and earthquakes. In line with the EU's strategy for smart, sustainable and inclusive growth (EU2020), standardization plays an important part in supporting the industrial policy for the globalization era. The improvement of the competition in EU markets through the adoption of the Eurocodes is recognized in the "Strategy for the sustainable competitiveness of the construction sector and its enterprises" – COM (2012)433, and they are distinguished as a tool for accelerating the process of convergence of different national and regional regulatory approaches.

With the publication of all the 58 Eurocodes Parts in 2007, the implementation of the *Eurocodes* is extending to all European countries and there are firm steps toward their adoption internationally. The Commission Recommendation of 11 December 2003 stresses the importance of training in the use of the Eurocodes, especially in engineering schools and as part of continuous professional development courses for engineers and technicians, which should be promoted both at national and international level. It is recommended to undertake research to facilitate the integration into the Eurocodes of the latest developments in scientific and technological knowledge.

In light of the Recommendation, DG JRC is collaborating with DG ENTR and CEN/TC250 "Structural Eurocodes" and is publishing the Report Series 'Support to the implementation, harmonization and further development of the Eurocodes' as JRC Scientific and Policy Reports. This Report Series includes, at present, the following types of reports:

1. Policy support documents – Resulting from the work of the JRC in cooperation with partners and stakeholders on 'Support to the implementation, promotion and further development of the Eurocodes and other standards for the building sector';
2. Technical documents – Facilitating the implementation and use of the Eurocodes and containing information and practical examples (Worked Examples) on the use of the Eurocodes and covering the design of structures or its parts (e.g. the technical reports containing the practical examples presented in the workshop on the Eurocodes with worked examples organized by the JRC);
3. Pre-normative documents – Resulting from the works of the CEN/TC250 and containing background information and/or first draft of proposed normative parts. These documents can be then converted to CEN technical specifications
4. Background documents – Providing approved background information on current Eurocode part. The publication of the document is at the request of the relevant CEN/TC250 Sub-Committee;
5. Scientific/Technical information documents – Containing additional, non-contradictory information on current Eurocode part, which may facilitate its implementation and use, or preliminary results from pre-normative work and other studies, which may be used in future revisions and further developments of the standards. The authors are various stakeholders involved in Eurocodes process and the publication of these documents is authorized by relevant CEN/TC250 Sub-Committee or Working Group.

Editorial work for this Report Series is assured by the JRC together with partners and stakeholders, when appropriate. The publication of the reports type 3, 4 and 5 is made after approval for publication from the CEN/TC250 Co-ordination Group.

The publication of these reports by the JRC serves the purpose of implementation, further harmonization and development of the Eurocodes. However, it is noted that neither the Commission

nor CEN are obliged to follow or endorse any recommendation or result included in these reports in the European legislation or standardization processes.

This report is part of the so-called Technical documents (Type 2 above) and contains a comprehensive description of the practical examples presented at the workshop “Design of concrete buildings with the Eurocodes” with emphasis on worked examples. The workshop was held on 20-21 October 2011 in Brussels, Belgium and was organized by the Joint Research Centre of the European Commission together with CEN/TC250/Sub-Committee 2 and Politecnico di Torino, with the support of CEN and the Member States. The workshop addressed representatives of public authorities, national standardisation bodies, research institutions, academia, industry and technical associations involved in training on the Eurocodes. The main objective was to facilitate training on Eurocode 2 through the transfer of knowledge and training information from the Eurocode 2 writers (CEN/TC250 Sub-Committee 2) to key trainers at national level and Eurocodes users.

The workshop was a unique occasion to compile a state-of-the-art training kit comprising the slide presentations and technical papers with the worked example of a concrete structure designed following *Eurocode 2*. The present JRC Report compiles all the technical papers and the worked example prepared by the workshop lecturers. The editors and authors have sought to present useful and consistent information in this report. However, it must be noted that the report does not present complete design example and that the reader may still identify some discrepancies between chapters. The chapters presented in the report have been prepared by different authors therefore are partly reflecting the different practices in the EU Member States. Users of information contained in this report must satisfy themselves of its suitability for the purpose for which they intend to use it.

We would like to gratefully acknowledge the workshop lecturers and the members of CEN/TC250 Sub-Committee 2 for their contribution in the organization of the workshop and development of the training material comprising the slide presentations and technical papers with the worked example. We would also like to thank especially Prof. Francesco Biasioli for the contribution, coordination of lecturers and support to the workshop.

All the material prepared for the workshop (slides presentations and JRC Report) is available to download from the “Eurocodes: Building the future” website (<http://eurocodes.jrc.ec.europa.eu>).

M. Poljanšek, S. Dimova, B. Nikolova, A. Pinto

European Laboratory for Structural Assessment (ELSA)

Institute for the Protection and Security of the Citizen (IPSC)

Joint Research Centre (JRC)

CHAPTER 1

CONCEPTUAL AND PRELIMINARY DESIGN

Francesco BIASIOLI and Giuseppe MANCINI

*Dipartimento di Ingegneria Strutturale, Edile e Geotecnica (DISEG),
Politecnico di Torino, Italy*

1.1 Introduction

The series of European standards commonly known as “Eurocodes”, *EN 1992 (Eurocode 2*, in the following also listed as *EC2*) deals with the design of reinforced concrete structures – buildings, bridges and other civil engineering works. *EC2* allows the calculation of action effects and of resistances of concrete structures submitted to specific actions and contains all the prescriptions and good practices for properly detailing the reinforcement.

EC2 consists of three parts:

- *EN 1992-1* *Design of concrete structures - Part 1-1 General rules and rules for buildings, Part 1-2 Structural fire design (CEN, 2002)*
- *EN 1992-2* *Design of concrete structures - Part 2: Concrete Bridges – Design and detailing rules (CEN, 2007).*
- *EN 1992-3* *Design of concrete structures - Part 3: Liquid retaining and containment structures (CEN, 2006).*

In the following, the principles of *Eurocode 2, part 1-1* are applied to the design of a simple design case study - a six-storey building with two underground parking storeys. This is similar to the one used for the Workshop on “*Eurocode 8: Seismic Design of Buildings*”¹. The aim of the exercise is to have two case studies referring to the same building, carrying the same vertical loads but two different sets of horizontal actions (*EC2*: vertical loads + wind; *EC8*: vertical loads + earthquake).

Design team

The design process has been divided between different authors, some of whom were involved in the preparation and/or assessment of *Eurocode 2*.

The parts and the authors are:

- F. Biasioli/G. Mancini: Basis of Design /Materials /Durability/ Conceptual design
- M. Curbach: Structural Analysis
- J. Walraven: Limit states design 1 (ULS - SLS)
- J. Arrieta: Detailing of reinforcement and members
- R. Frank Foundation Design
- F. Robert Fire design

This document deals with the definition of actions, the assessment of durability, the selection of materials and the “conceptual design” of the geometry of the structure.

Conceptual design has been defined as “...choosing an appropriate solution among many possible ones, in order to solve a particular problem taking into account functional, structural, aesthetical and sustainability requirements...”². Using a sort of “reverse engineering” of a number of *EC2* equations, suitable hints and rules to be used during this design stage are proposed.

¹ Details on Eurocode 8 workshop: see http://eurocodes.jrc.ec.europa.eu/showpage.php?id=335_2

² H. Corres Peiretti - Structural Concrete Textbook - *fib* bulletin 51, Lausanne 2012

1.2 Basic data

1.2.1. General data and preliminary overview

The building (6 floors + 2 underground parking levels) is ideally located in an urban area (terrain category IV for wind actions) not close to the sea, at 300 m AMSL (Above Mean Sea Level). The ground floor is occupied by offices open to public, 1st to 5th floor are for dwellings and the roof is not open to public. The dimensions in plan are (30,25 x 14,25) m, the plan surface is 431 m² and the height is $h = 25$ m (Figures 1.2.3 – 1.2.4). A conventional working life of 50 years is assumed for design.

The structure consists mainly of reinforced concrete frames. Compared to the *EC8* example previously cited, the size of the building and the layout of columns remain unchanged, but the geometry of some vertical elements (columns and walls) has been changed: shear walls from the staircase area are substituted by columns as well as two new walls have been added along outer alignments no.1 and 6 (see Figure 1.2.3 and Figure 2.1.1. in Chapter 2.1).

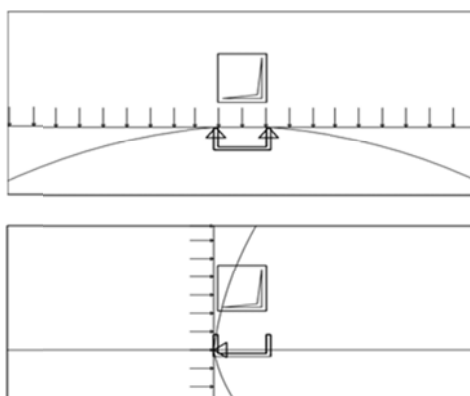

Fig.1.2.1 Slab deformation

The reason for this is that in the *EC8* example, the internal stairs wall and lift core were used as bracing elements. Assuming that horizontal loads (due to wind or earthquakes) are uniformly applied to the slab (if due to the limited stiffness of columns this is idealized as a beam supported by the core only), Figure 1.2.1 gives evidence of the slab deformations in both X- and Y-directions. To reduce these and to increase the building's torsional rigidity, peripheral walls should be added (see Figure 1.2.2). As the stiffness of the slab in the X-direction is relevant, as well as the stiffness of the core in the same direction, walls in the X-direction may not be present.

The inner columns are founded on square spread foundations of dimensions $(B \cdot L) = (2 \cdot 2)$ m; the outer columns and the shear walls are supported by a peripheral diaphragm retaining wall of width 0,6 m, height 9 m, embedded 3 m below the 2 levels of the parking (see Chapter 5).

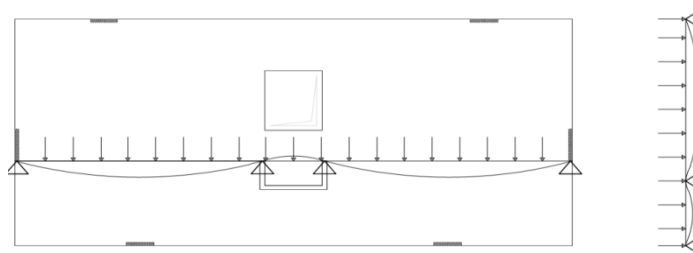

Fig.1.2.2 Peripheral walls

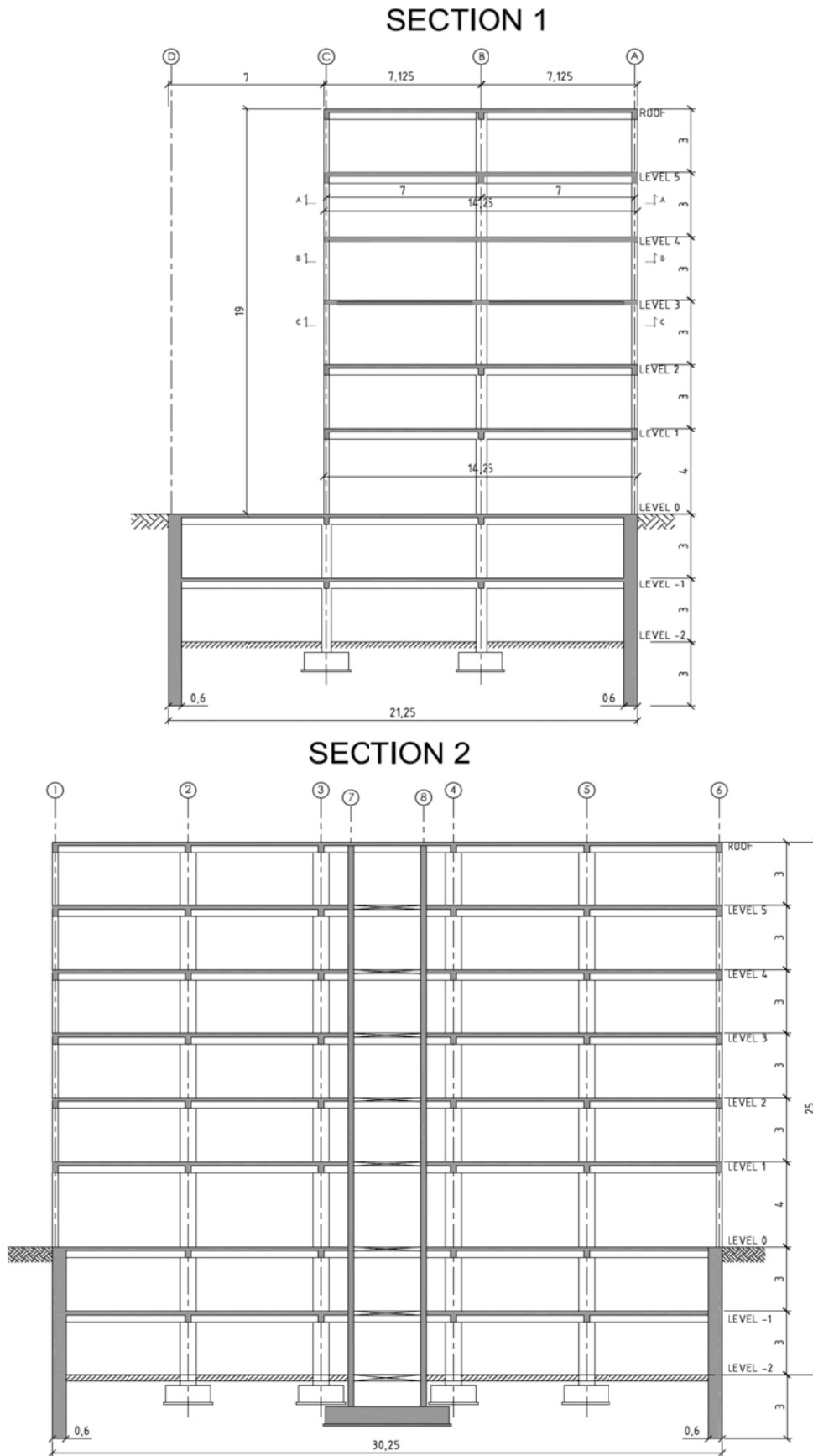

Fig.1.2.3 EC2 Reinforced concrete building – sections

1.2.2. Slab geometry

Slab bays have equal spans in X- and Y-directions: in X-direction such equality never gives the most efficient structural solution, as long-term deflection of the outer bays governs the depth h of the slab. With some lack of optimization - the X-direction spans of the outer bays, wherever possible, should be not greater than 90% of those of the adjacent inner bays.

To cover different building solutions commonly used in Europe, three slab alternatives have been considered. The first (A-A) solution is a two-way concrete solid slab with depth³ $h = 18$ cm supported by (0,25 x 0,32) m protruding beams in the X- and Y-directions (Figure 1.2.4). Justification of the geometry of structural elements is given later. This solution reduces both depth and reinforcement of the slab, but has the inconvenience of protruding beams, which may hinder matching the internal walls sequence, especially for dwellings.

For a safe preliminary evaluation of the quantity of materials the slab “voids” due to stairs and lifts may be assumed as not present. The resulting extra volume of concrete takes into accounts deformations of formworks and any loss of concrete during casting (pump filling, etc.). The overall quantity of concrete is $(30,25 \times 14,25) \cdot 0,18 + (6 \cdot 14,25 + 3 \cdot 30,25) \cdot 0,32 \cdot 0,25 = 77,6 + 14,1 = 91,7 \text{ m}^3$.

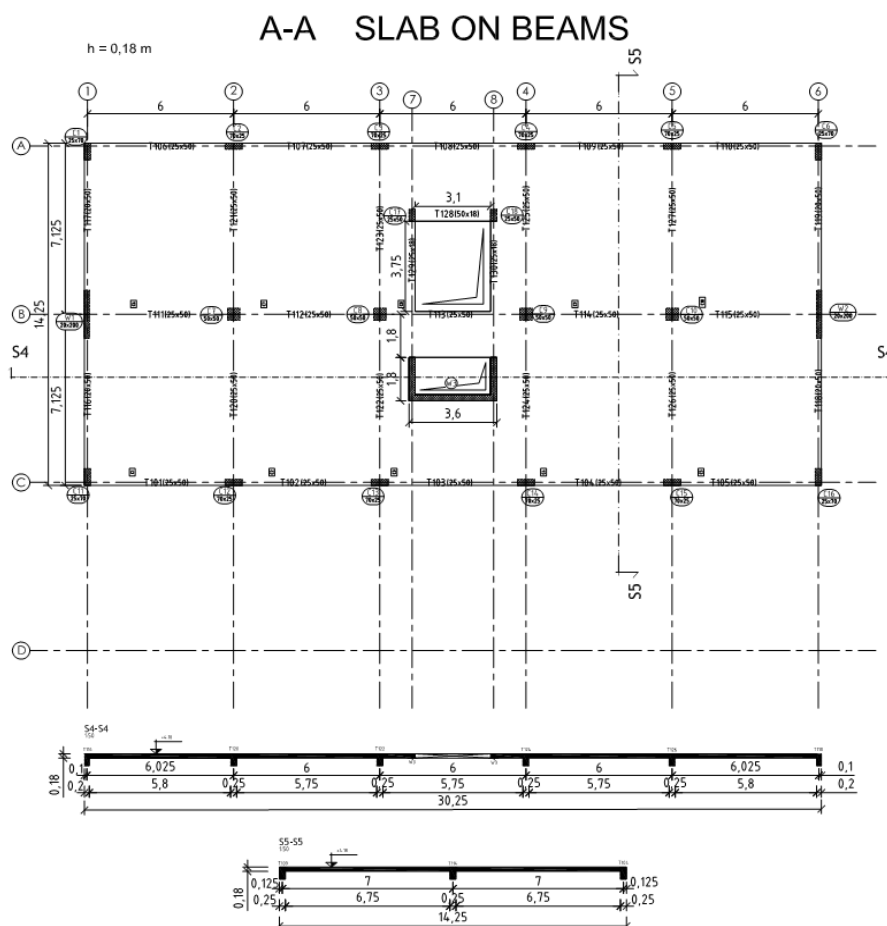

Fig.1.2.4 Slab $h = 0,18$ m on (0,25 x 0,32) m beams

³ Justification of the height for the three solutions are given later in the chapter.

The second (B-B) solution is a flat concrete solid slab with depth $h = 24$ cm spanning in both X- and Y-directions (Figure 1.2.5). This solution, very common in a number of countries, has the advantage of the absence of protruding beams. In recent years it has been improved by the availability of advanced scaffolding and formwork systems (lightweight elements with dropheads allowing easy scaffolding and early striking) as well as reinforcing systems (ordinary steel “carpets” tailor designed, or post-tensioned unbonded tendons in the case of longer spans and/or heavier weights).

The design focuses in the case of flat slabs are:

- 1) deflection (in this case also governed by the outer bays)
- 2) punching resistance (columns C7 and C10).

Ignoring as before the “voids” of stairs and lifts, the overall quantity of concrete (dimensions in m) is $(30,25 \cdot 14,25) \cdot 0,24 = 103,4 \text{ m}^3$.

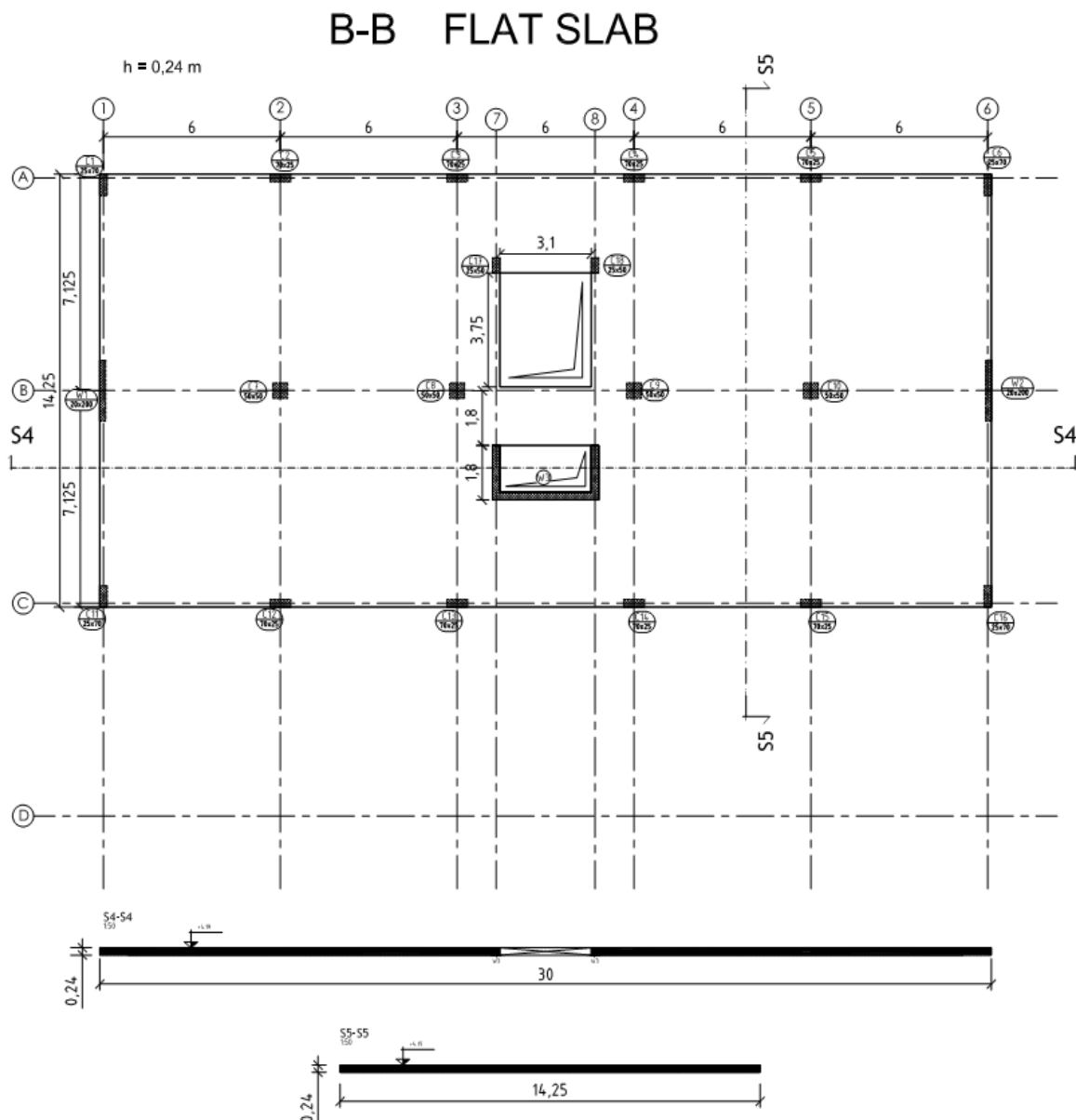

Fig.1.2.5 Flat Slab $h = 0,24 \text{ m}$

The third (C-C) solution is a slab of total height $h = 0,23$ m with embedded lighting clay elements⁴. Ribs spanning in Y-direction are supported by protruding T-beams in X-direction (lateral: $(0,25 \times 0,30)$ m; central: $(0,25 \times 0,17)$ m). Two beams in Y-direction $(0,25 \times 0,30)$ m are provided at both slab ends (Figure 1.2.6).

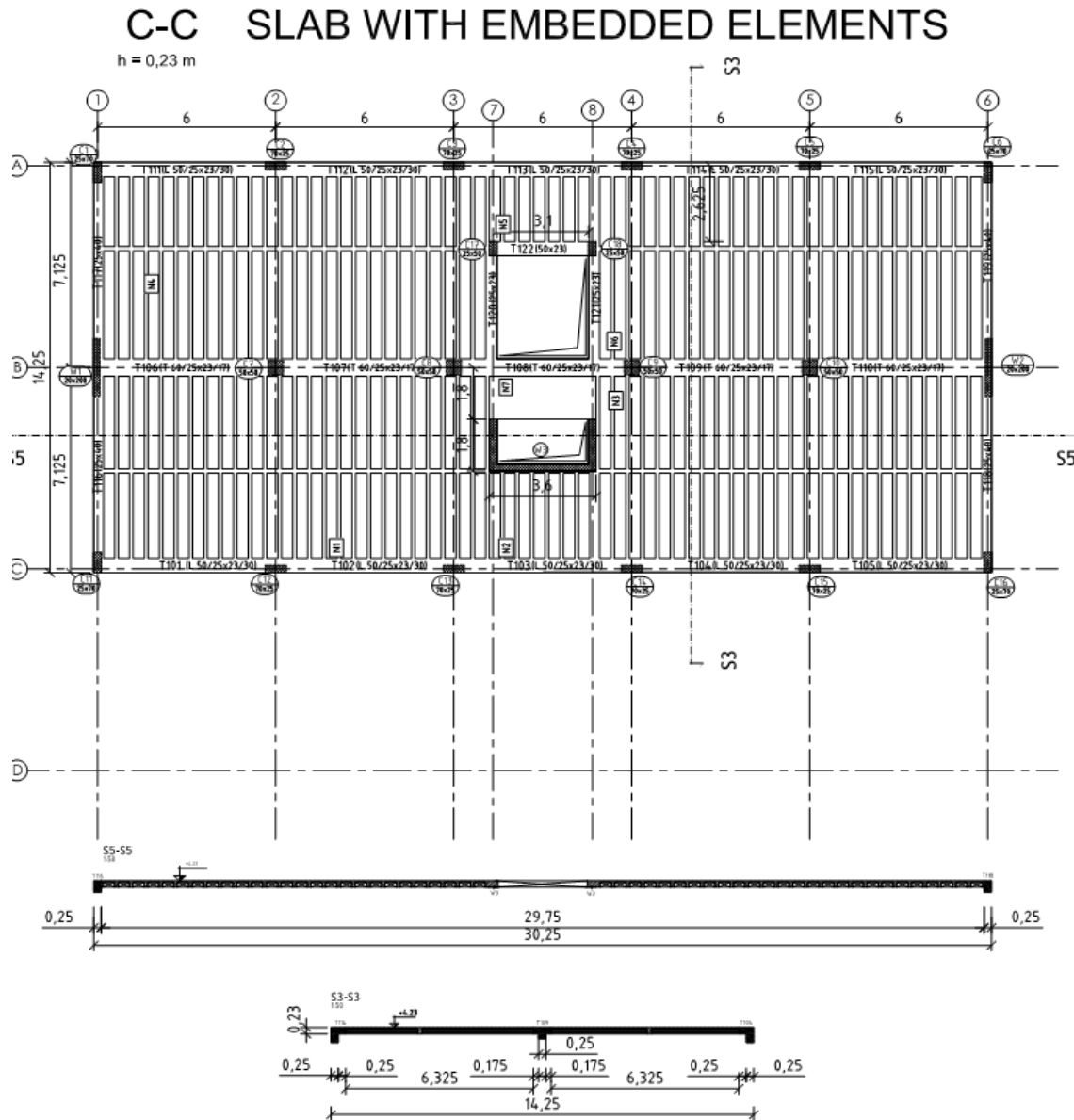

Fig.1.2.6 Slab with embedded elements $h = 0,23$ m

In Figure 1.2.7 an example of a clay lighting element is given: it forms every $0,50$ m a T-section with web height $h = 0,18$ m and width $b_w = 0,12$ m. The flange depth is $h_f = 0,05$ m. These elements require a supporting scaffolding plan, an alternative being filigree concrete slabs with embedded EPS which have embedded temporary reinforcement therefore can be laid down on discrete supports.

⁴ Besides clay, embedded lighting elements could also be made of EPS (expanded polystyrene), concrete, plastics or wood.

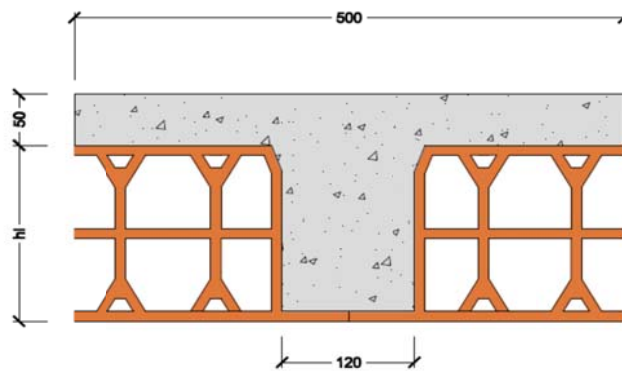

Fig.1.2.7 Clay lighting element $h = 0,23$ m

The unit concrete quantity for 1 m element (2 ribs) is $(2 \cdot 0,12 \cdot 0,18) + 0,05 = 0,093 \text{ m}^3/\text{m}^2$.

The overall quantity of concrete, evaluated as before, and disregarding stairs and lifts voids is $(30,25 - 2 \cdot 0,40) \cdot [14,25 - (2 \cdot 0,50 + 0,60)] \cdot 0,093 + [2 \cdot (0,40 \cdot 0,23 + 0,25 \cdot 0,30)] \cdot (14,25 - 2 \cdot 0,50) + [2 \cdot (0,50 \cdot 0,23 + 0,25 \cdot 0,30) + (0,60 \cdot 0,23 + 0,25 \cdot 0,17)] \cdot 30,25 = 34,6 + 4,4 + 17,0 = 56,0 \text{ m}^3$.

Compared to the two other, this is the solution requiring the least amount of concrete.

1.3 Actions

Actions have been obtained from the following parts of *EN1991*:

- *EN1991-1.1* Densities, self-weight and imposed loads
- *EN1991-1.2* Fire actions
- *EN1991-1.3* Snow loads
- *EN1991-1.4* Wind loads

Due to the limited dimensions of the building, thermal actions were not considered, nor were impact and explosion actions.

Where available, gamma partial safety factors are taken as the suggested values in *EC2*.

1.3.1. Densities, self-weight, imposed loads, partial and combination factors

Self-weight G_1	$\gamma_G = 1,35$ (unfavourable)
Reinforced concrete:	25 kN/m^3
Embedded clay elements $h = 0,18$ m:	$0,75 \text{ kN/m}^2$
Permanent loads G_2	$\gamma_G = 1,35 \div 1,0$
Finishing, pavement, embedded services, partitions:	$3,0 \text{ kN/m}^2$
Walls on external perimeter (windows included):	$8,0 \text{ kN/m}$
Variable loads Q_i	$\gamma_Q = 1,50 \div 0$

Table 1.3.1 Variable loads

Type	q_k (kN/m ²)	ψ_0	ψ_2
Dwelling	2,00	0,70	0,30
Stairs, office open to public	4,00		
Snow	1,70	0,50	0,00
Parking	2,50	0,70	0,60

1.3.2. Wind

The combination factors considered are:

$$\psi_0 = 0,60, \quad \psi_2 = 0,0$$

As already outlined, the building is ideally located in an urban area (terrain category IV) not close to the sea, at 300 m AMSL (Above Mean Sea Level). The assumed values (EN 1991-1.4) are:

- o Basic wind velocity

$$V_b = C_{dir} C_{season} V_{b,0} \quad C_{dir} = C_{season} = 1,0 \quad v_{b,0} = 30 \text{ m/s} \quad v_b = v_{b,0} = 30 \text{ m/s}$$

- o Terrain category IV

$$z_0 = 1 \quad z_{min} = 10 \text{ m}$$

- o Terrain factor

$$k_r = 0,19 \left(\frac{z_0}{0,05} \right)^{0,07} = 0,19 \left(\frac{10}{0,05} \right)^{0,07} = 0,234 \text{ m/s}$$

- o Orography factor

$$c_o = 1,0$$

- o Turbulence intensity

$$k_t = 1,0 \quad I_v(z) = \frac{k_t}{c_o(z) \ln z/z_0} = \frac{1}{\ln z/z_0}$$

- o Exposure factor $c_e(z)$ taking into account turbulence

$$z \leq 10 \text{ m}$$

$$c_e(z) = c_e(z_{min}) = k_r^2 c_o \ln \frac{z}{z_0} \left(7 + c_o \ln \frac{z}{z_0} \right) = 0,23^2 \cdot 1 \cdot \ln \frac{10}{1} \left(7 + 1 \cdot \ln \frac{10}{1} \right) = 1,13 \text{ const.}$$

$$z > 10 \text{ m}$$

$$c_e(z) = k_r^2 c_o \ln \frac{z}{z_0} \left(7 + c_o \ln \frac{z}{z_0} \right) = 0,053 \cdot \ln z (7 + \ln z).$$

- o Basic velocity pressure

$$q_b = \frac{1}{2} \rho v_b^2 = \frac{1}{2} \cdot 1,25 \cdot 30^2 \cdot 10^{-3} = 0,563 \text{ kN/m}^2$$

- o Peak velocity pressure

$$z \leq 10 \text{ m} \quad q_p(z_e) = c_e(z) q_b = c_e(z) 0,563 \text{ kN/m}^2$$

$$z > 10 \text{ m} \quad q_p(z_e) = c_e(z_{min}) q_b = c_e(10) 0,563 \text{ kN/m}^2$$

- o Wind pressure on external surfaces

$$c_{pe} = +0,8 \quad c_{pe} = -0,4$$

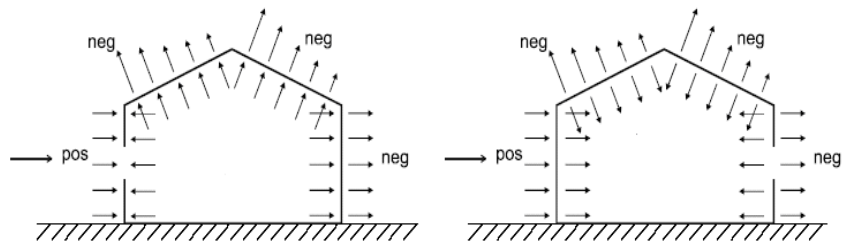

Fig.1.3.1 Wind pressure on external surfaces

- o Structural factor

$$c_s c_d = 1,0 \text{ (framed buildings with structural walls less than 100 m high)}$$

Wind pressure on external surfaces

$$w_e = q_p(z_e) c_{pe} c_s c_d = q_p(z_e) (0,8 - (-0,4)) \cdot 1 = 1,2 q_p(z_e) \text{ kN/m}^2$$

- o $z > 10 \text{ m}$

$$w_e(z_e) = 1,2 \cdot c_e(z_e) 0,56 = 0,035 \cdot \ln(z_e) [7 + \ln(z_e)] \text{ kN/m}^2$$

$$w_e(19) = 1,04 \text{ kN/m}^2$$

- o $z \leq 10 \text{ m}$

$$w_e(10) = 0,0357 \cdot \ln(10) [7 + \ln(10)] = 0,77 \text{ kN/m}^2$$

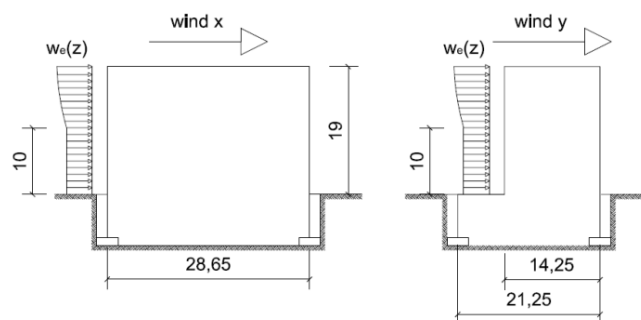

Fig.1.3.2 Wind pressure on external surfaces – example

1.3.3. Snow load

The snow load is described in Chapter 2.

1.4 Materials

1.4.1. Concrete

1.4.1.1 Exposure classes and concrete strength class

EC2 requires (2.4) that “...the structure to be design such that deterioration over its design working life does not impair the performance of the structure below that intended, having due regard to its environment and the anticipated level of maintenance...”. Environmental influences are therefore considered for assessing the durability of concrete structures.

EC2 basically refers to a

- a 50-years design working life,
- “normal” supervision during execution,
- “normal” inspection and maintenance during use. Quality management procedures to be adopted during execution are described in EN13670.

For what concerns deterioration of concrete and corrosion of reinforcing steel due to potentially aggressive environment, the designer has to identify the (anticipated) conditions of the environment where the structure will be located “...in order to take adequate provision for protection of the materials used in the structure...”. Environmental exposure conditions are classified by “exposure classes”. An example is given in Figure 1.4.1.

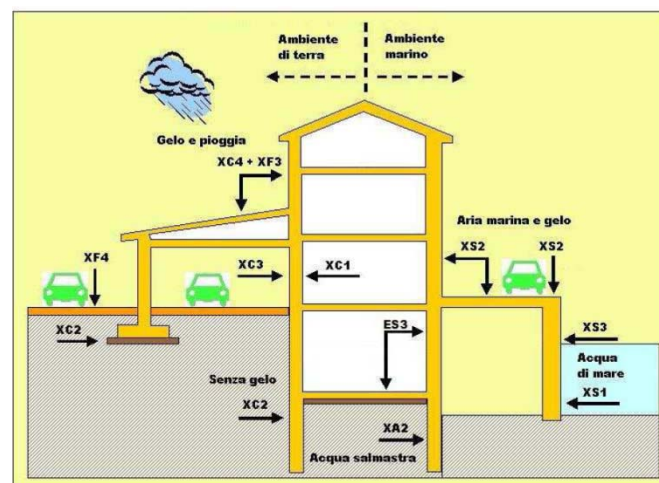

Fig.1.4.1 Environmental exposure classes⁵

⁵ **Legend** : Ambiente di terra = ground environment; ambiente marino = seaside environment; gelo e pioggia = frost and water; aria marina e gelo = sea airborne and frost; senza gelo = no frost; acqua salmastra = salty water; acqua di mare = sea water

"Deemed to satisfy" rules related to the different exposure classes of the structural members are given in: *EN206-1 Annex F* (concrete standard) for a) minimum concrete strength class and b) concrete composition; and in *EN 1992-1* for c) minimum concrete cover to reinforcement and, for more critical exposure classes, d) maximum allowed crack width.

In both *EC2* and *EN206* concrete strength is used as indirect measure of concrete durability, on the basis of the assumption: higher strength → less porous concrete → higher durability. Complementary information is given in *EN206* National Annexes about the maximum water/cement ratio and minimum cement content per m³ of concrete. The result is a large variation of requirements in different EU countries⁶.

1.4.1.2 Exposure classes, structural classes and concrete cover

Exposures classes are identified by the letter X followed by the initial letter (in English) of the deterioration mechanism to which they refer:

- Corrosion of reinforcement due to **C**arbonation (**XC**) or to chlorides from **D**e-icing agents, industrial wastes, pools (**XD**), or from **S**ea water (**XS**)
- Deterioration of concrete due to **F**reeze/thaw action (**XF**) or chemical **A**ttack (**XA**).

According to *EC2*, chapter 4, to design the minimum concrete cover required for all reinforcement (stirrups included) the sequence is:

1. Identify the exposure class(es) for the different structural elements
2. Identify the MINIMUM strength class for each exposure class(es) (*EC2 Informative annex E* and *EN206, Annex F* - use multiple classes only if separate casting sequences are provided (e.g. foundations vs. walls, columns vs. slabs etc.);
3. Identify the MINIMUM cover for both durability ("dur") and bond ("b")

$$c_{min} = \max [c_{min,b}; (c_{min,dur} - \Delta c_{dur,add}); 10 \text{ mm}] \quad (1.1)$$

Concrete surface protections, if any, are taken into account by the cover reduction term $\Delta c_{dur,add}$.

4. Identify the nominal reinforcement concrete cover c_{nom} (Figure 1.4.2) to be used in drawings and for reinforcement detailing

$$c_{nom} = \max [(c_{min} + \Delta c); 20 \text{ mm}] \quad (1.2)$$

Besides bond and steel corrosion protection, c_{nom} has also to take into account resistance to fire. $\Delta c = 0 - 10 \text{ mm}$ is the «execution tolerance».

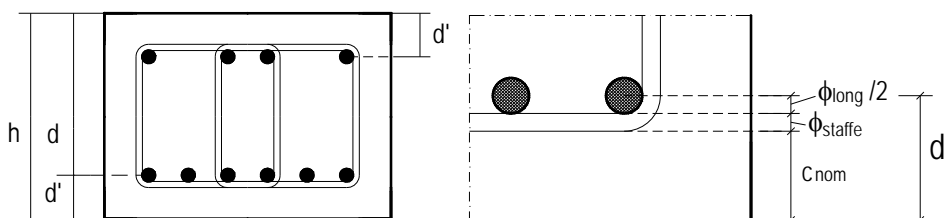

Fig.1.4.2 Nominal concrete cover c_{nom}

⁶ CEN/TR 15868:2009 - Survey of national requirements used in conjunction with *EN206-1:2000*

As it is not possible to generalise or take into account the provisions valid in all countries, in the design example the following exposure classes and related concrete strength classes have been used:

XC1	for internal slabs, beams and foundations	C25/30
XC2	for columns	C30/37 > C25/30

Even when the environment is the same for slabs and columns, the concrete class used for columns should preferably be higher than the one used for slabs and beams, as suggested by the *Eurocode 8* “capacity design” rule: in the case of seismic structures, to guarantee building stability and avoid the “soft storey” mechanism, plastic hinges required for energy dissipation have to occur in horizontal elements only and never in vertical ones (Figure 1.4.3).

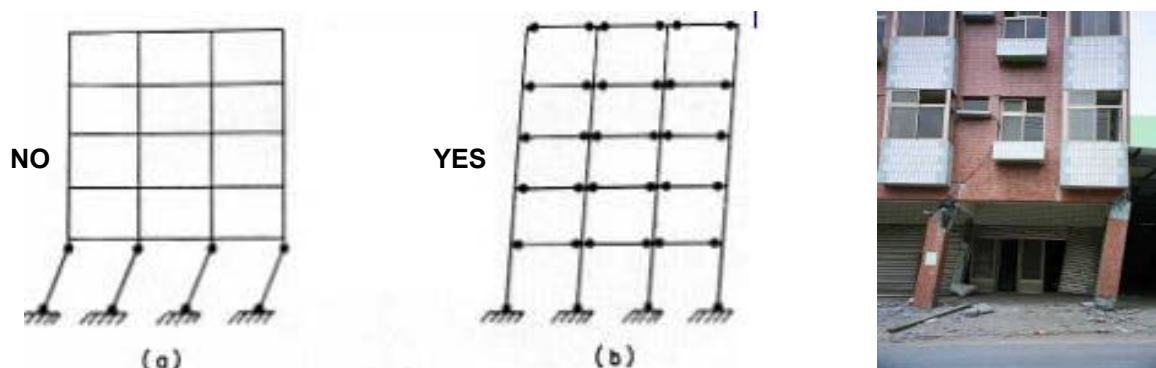

Fig.1.4.3 Soft-storey mechanism

To identify the minimum concrete cover for durability $c_{min,dur}$ once the environmental class and the related concrete strength class have been identified, the “structural class” may be chosen using *Eurocode 2, Table 4.3N*. *Eurocode 2* considers structural class S4 as the “default” one, to be modified on the basis of criteria listed in Table 1.4.1.

Table 1.4.1 Recommended structural classification (*EC2 Table 4.3N*)

Criterion	Structural Class						
	Exposure Class according to Table 4.1 (<i>Eurocode 2</i>)						
	X0	X1	XC2/XC3	XC4	XD1	XD2 / XS1	XD3 / XS2 / XS3
Design Working Life of 100 years	increase class by 2	increase class by 2	increase class by 2	increase class by 2	increase class by 2	increase class by 2	increase class by 2
Strength Class ¹⁾²⁾	$\geq C30/37$	$\geq C30/37$	$\geq C35/45$	$\geq C40/50$	$\geq C40/50$	$\geq C40/50$	$\geq C45/55$
Member with slab geometry (position of reinforcement not affected by construction process)	reduce class by 1	reduce class by 1	reduce class by 1	reduce class by 1	reduce class by 1	reduce class by 1	reduce class by 1
Special Quality Control of the concrete production ensured	reduce class by 1	reduce class by 1	reduce class by 1	reduce class by 1	reduce class by 1	reduce class by 1	reduce class by 1

Assuming a 50 years working life and no special concrete production Quality Control, for this example the structural classes are

- Slabs: concrete C25/30 S(4 – 1) = S3 reduction for slab geometry
- Beams: concrete C25/30 S4 no reduction
- Columns: concrete C30/37 S4 no reduction

On the basis of the environmental and structural classes the minimum concrete cover for durability may be identified (Table 1.4.2 below is the one used in *Eurocode 2*, national tables may be different):

Table 1.4.2 Values of minimum cover (*Eurocode 2 Table 4.4N*)

Environmental Requirement for $c_{min,dur}$ (mm)							
Structural Class	Exposure Class according to Table 4.1 (<i>Eurocode 2</i>)						
	X0	XC1	XC2 / XC3	XC4	XD1 / XS1	XD2 / XS2	XD3 / XS3
S1	10	10	10	15	20	25	30
S2	10	10	15	20	25	30	35
S3	10	10	20	25	30	35	40
S4	10	15	25	30	35	40	45
S5	15	20	30	35	40	45	50
S6	20	25	35	40	45	50	55

- $c_{min,dur}$ - slabs (XC1/S3) = 10 mm
- $c_{min,dur}$ - beams (XC1/S4) = 15 mm
- $c_{min,dur}$ - columns (XC2/S4) = 25 mm

Assuming $\Delta_{c,dev} = 5$ mm for controlled execution, the calculated nominal cover to reinforcement c_{nom} is:

- slabs $c_{nom} = c_{min,dur} + \Delta_{c,dev} = \max(15+5; 20) = 20$ mm
- beams $c_{nom} = \max(20+5; 20) = 25$ mm
- columns $c_{nom} = \max(25+5; 20) = 30$ mm

Resulting cover values have always to be rounded upwards to the nearest 5 mm.

For earth retaining walls and foundations $c_{nom} = 40$ mm is common, due to the difficulty of any visual inspection to detect deterioration

On the basis of the *EC2* nationally determined parameters and *EN206* national provisions, the whole procedure can be easily implemented in an Excel™ spreadsheet (Figure 1.4.4).

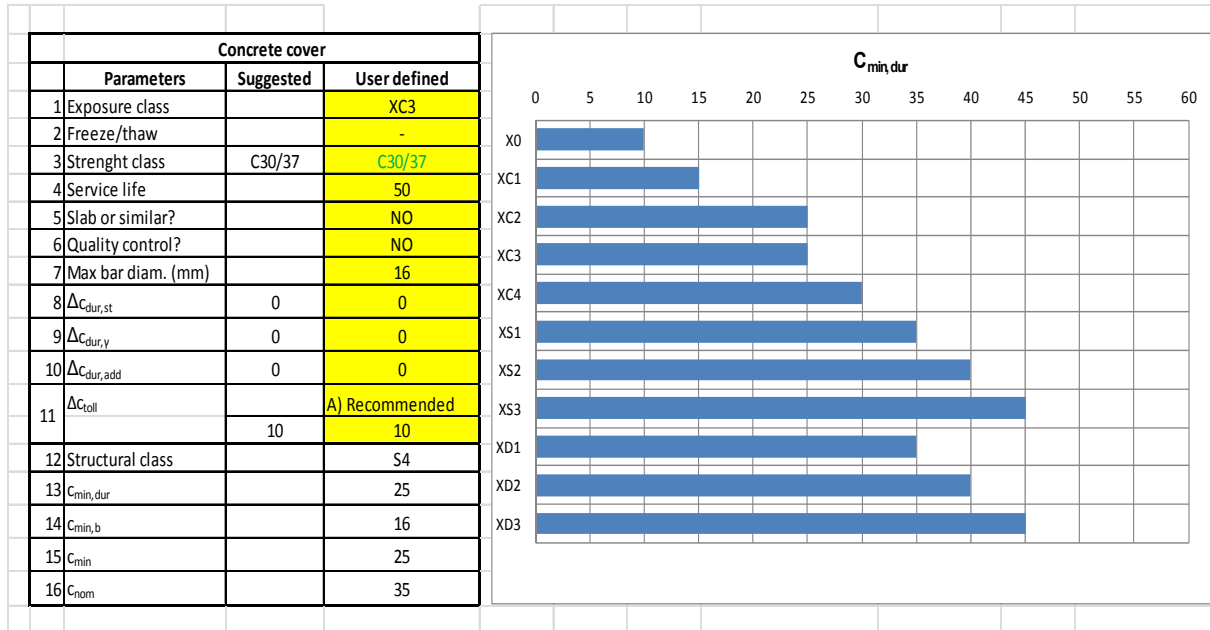

Fig.1.4.4 Excel procedure for calculating the minimum concrete cover

Alternatively, national tables with all information related to the required concrete composition may be prepared. An example valid for Italy is given in Figure 1.4.5.

Classe di esposizione ambientale	Copriferro $c_{min,dur}$ [mm]								
	15	25	30	35	40	45	50	55	
XC1									C25/30; 0,60; 300
XC2									C25/30; 0,60; 300
XC3									C28/35; 0,55; 320
XC4									C32/40; 0,50; 340
XD1									C28/35; 0,55; 320
XD2									C35/45; 0,45; 360
XD3									C35/45; 0,45; 360
XS1									C28/35; 0,55; 320
XS2									C35/45; 0,45; 360
XS3									C35/45; 0,45; 360
XF1									C28/35; 0,50; 320
XF2 – XF3									C25/30; 0,50; 340
XF4									C28/35; 0,45; 360
XA1									C28/35; 0,55; 320
XA2									C32/40; 0,50; 340
XA3									C35/45; 0,45; 360

Tab. 26.02 - Copriferro c_{min} e composizione del calcestruzzo (EN206-1 ed EC2)

Fig.1.4.5 Minimum concrete cover (Copriferro) for durability, concrete strength class and concrete composition (composizione del calcestruzzo) (Italy data)

1.4.2. Reinforcing steel

1.4.2.1 Steel characteristics

Medium ductility S500 B (grade 500 class B) reinforcing steel has been adopted. In the idealised and design stress-strain diagrams the lower elasto-plastic design curve B without stress-hardening has been used (Figure 1.4.6).

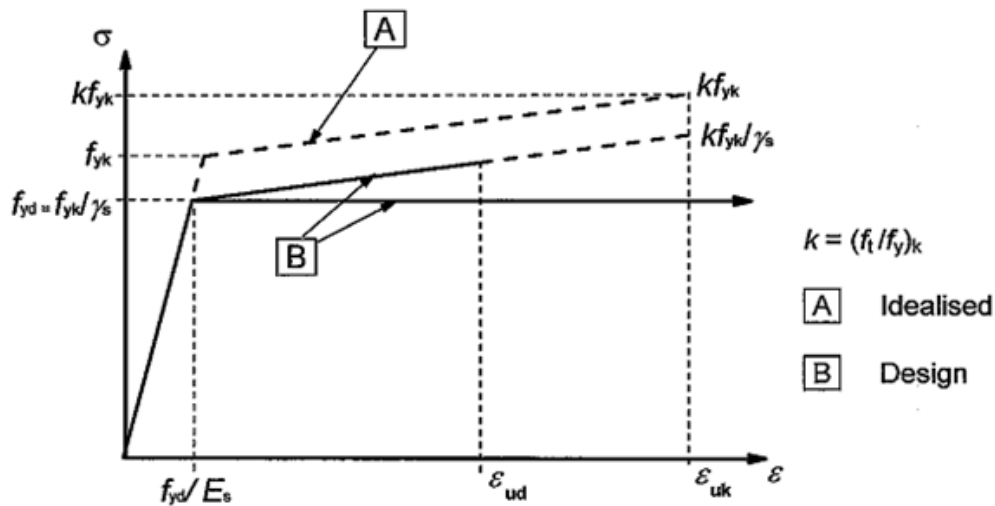

Fig.1.4.6 Reinforcing steel – design stress-strain diagrams

Assuming partial safety coefficients $\gamma_s = 1,15$ for Ultimate Limit State (ULS - persistent and transient design situation) and $\gamma_s = 1,0$ for Serviceability Limit States (SLS), the characterizing values of the diagram are:

- o Strength

$$f_{yk} \geq 500 \text{ N/mm}^2; \quad E_s = 200 \text{ kN/mm}^2; \quad (f_{y,max} \leq 1,30 f_{yk}, f_{yk} \leq 650 \text{ N/mm}^2)$$

$$f_{yd} = 500 / 1,15 = 435 \text{ N/mm}^2; \quad \varepsilon_{s,yd} = f_{yd} / E_s = 435/200 = 2,17\%$$

- o Ductility

$$k = (f_t / f_y)_k \geq 1,08 \quad \varepsilon_{uk} \geq 5\% \quad \varepsilon_{ud} = 0,90\varepsilon_{uk} \geq 4,5\%$$

1.4.2.2 Maximum bar diameters

The design of the geometry of concrete structures, especially of concrete buildings, is increasingly governed by considerations of Serviceability Limit States (SLS - deformation, cracking, stress limitation) rather than those of Ultimate Limit States (ULS). It is therefore important to identify in EC2 the limiting values for the different SLSS, if any, to be considered in design.

For crack widths up to a maximum of 0,30 mm – the upper limit for all environmental classes according to EC2, Table 7.1N - the SLS of cracking may be verified without calculation by limiting either the diameter of reinforcing bars as a function of steel stress, or their maximum spacing. For a S500 B steel and various concrete classes stress Table 1.4.3 gives maximum bar diameters as a function of steel stress ratio σ_s / f_{yk} evaluated in a cracked section under the quasi permanent (Q_P) load condition – bold values are EC2 ones.

Table 1.4.3 Maximum bar diameters for crack control

Steel 500B		Concrete class				
		C20/25	C25/30	C30/37	C35/45	C40/50
$f_{ct,eff}$		2,3	2,6	2,9	3,4	3,6
σ_s	σ_s / f_{yk}	$\Phi_{l,max}$ for crack width $w_k=0,30$ mm				
160	0,32	24	28	32	36	38
170	0,34	22	26	30	34	36
180	0,36	22	24	28	32	34
190	0,38	20	22	26	30	32
200	0,40	18	20	24	26	28
210	0,42	16	18	22	24	26
220	0,44	14	16	20	22	24
230	0,46	14	16	18	20	22
240	0,48	12	14	16	18	20
260	0,52	10	12	14	16	16
280	0,56	10	10	12	14	14

Note: EC2 values up to f_{yk} : 25 mm for $\sigma_s = 200$ MPa

In conceptual design commonly used bar diameters are first selected, then the related maximum limiting values of $\sigma_{s,QP} / f_{yk}$ are identified. In this case they are:

- Slabs: $\phi 14$ mm C25/30 $\sigma_{s,QP} / f_{yk} \leq 0,48$
- Beams: $\phi 16$ mm C25/30 $\sigma_{s,QP} / f_{yk} \leq 0,42$
- Columns: $\phi 20$ mm C30/37 $\sigma_{s,QP} / f_{yk} \leq 0,44$

These limiting ratios will be considered in design (see forward).

1.5 Conceptual design of slabs

1.5.1 Slab height

1.5.1.1 Slenderness

The design of slabs has to fulfil both Serviceability Limit States (SLS) and Ultimate Limit States (ULS) requirements (in this exact order!). In general the height “ h ” of slabs is controlled by the deflection limits (EC2 7.4). In the case of flat slabs, punching frequently also governs.

In EC2 the deemed-to-satisfy rule for verifying SLS deflection is based on the limitation of elements’ “slenderness” by setting maximum “slenderness ratios” (l_{ef}/d) of the “effective span” l_{ef} (axis-to-axis distance in the case of supporting beams, or centre-to-centre distance of columns in the case of flat

slabs) to the “effective depth”, d , (distance of the centroid of the tensile forces from the most compressed concrete fibre).

For flat slabs with spans $\leq 8,5$ m and slab and beams with spans ≤ 7 m, as in this example, *EC2*, paragraph 7.4.2 gives the formula

$$\frac{l_{ef}}{d} = Ks \frac{310}{\sigma_s} \left(\frac{l}{d}\right)_0 = Ks \frac{500}{f_{yk}} \frac{A_{s,prov}}{A_{s,req}} \left(\frac{l}{d}\right)_0 \quad (1.3)$$

K takes into account the type, restraints and relative position of each element in the structural system. It transforms the “effective span” into the so-called “normalized span”

$$l_n = l_{ef} / K \quad (1.4)$$

of an ideal simply supported (SS) element which has the same deflection as the actual element. For a slab of constant height h subjected to the same permanent G_2 and variable Q loads, the bay governing the whole slab height, the one with the maximum “normalized span”, can be easily identified as the one having the greatest normalized span l_n .

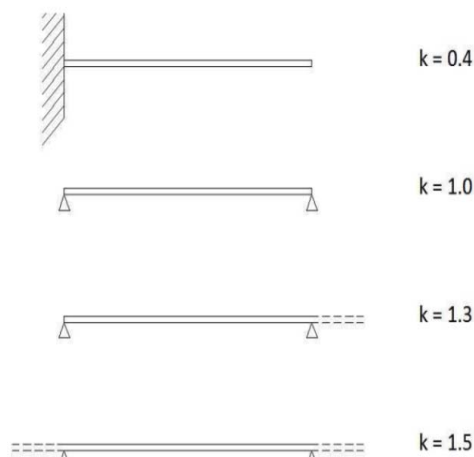

Fig.1.5.1 K values vs. structural systems

As already mentioned K values demonstrate that continuous slabs or beams with spans all equal, as in this example, never represent a good structural solution: the span of the external slab (or beam) should never be longer than $(1,3/1,5) \cdot 100 = 87\%$ of the adjacent internal slab span.

The “shape” factor s , takes into account the geometry of the slab transverse section, in particular the variation of its section moment of inertia. *EC2* assumes $s = 1,0$ for R(rectangular) sections, as solid slabs, or compact T-sections with $b/b_w \leq 3$; $s = 0,80$ for T-sections with $b/b_w > 3$, as is the case of slabs with embedded elements (Figure 1.2.7) where $b/b_w = 500/120 = 4,8 > 3$.

$(l/d)_0$ is the “reference span to depth ratio”. In the case of slabs with $\rho \leq \rho_0$ *EC2* gives:

$$\left(\frac{l}{d}\right)_0 = 11 + 1,5\sqrt{f_{ck}} \frac{\rho}{\rho_0} + 3,2\sqrt{f_{ck}} \sqrt{\left(\frac{\rho}{\rho_0} - 1\right)^3} \quad \rho_0 = 10^{-3} \sqrt{f_{ck}} \quad (1.5)$$

$\rho = A_s / (bd)$ is the geometrical reinforcement ratio of the steel area A_s in tension. For a number of selected concrete classes $(l/d)_0$ and ρ_0 values calculated with the formulae above are given in Table 1.5.1.

Table 1.5.1 $(l/d)_o$ and ρ_o values for selected concrete classes

	C20/25	C25/30	C30/37	C32/40	C35/45
ρ_o (%)	0,45	0,50	0,55	0,57	0,59
$(l/d)_o$	19	20	20	21	18

In Figure 1.5.2 the $(l/d)_o$ hyperbolic formula above is represented on the left side: bullet points calculated for $\rho = \rho_o$ divide (lightly-reinforced) slabs from (medium- to heavily-reinforced) beams.

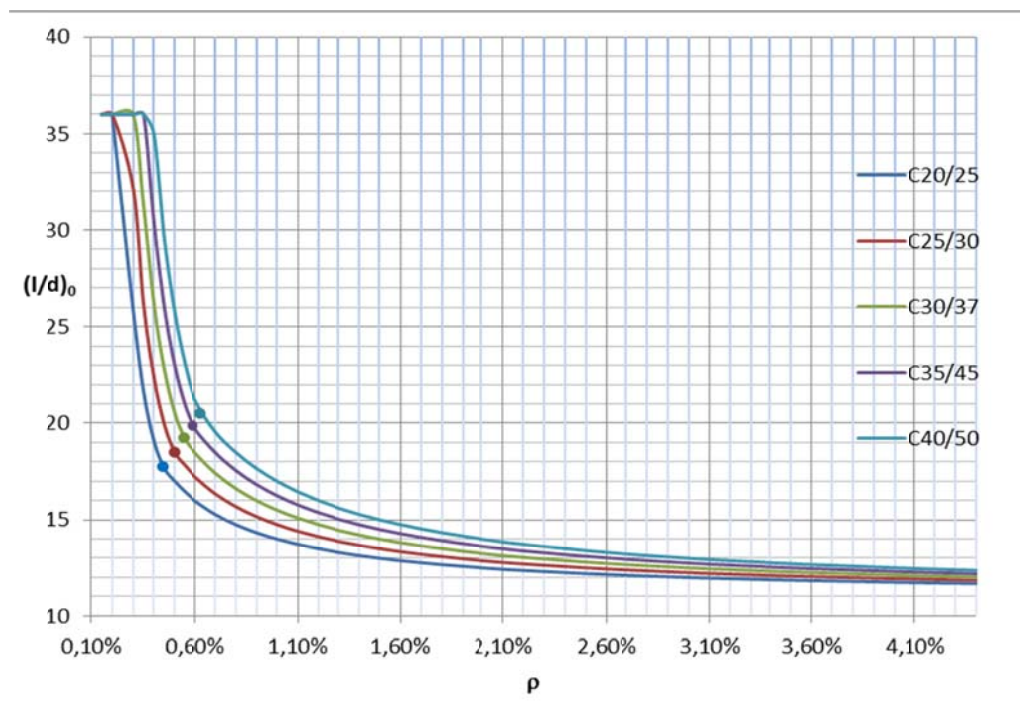

Fig.1.5.2 $(l/d)_o$ function of geometrical reinforcement ratio ρ

In the case of low reinforcement ρ ratios the EC2 formula gives very high $(l/d)_o$ slenderness values which, if not properly assessed, could lead to excessively slender slabs. The maximum $(l/d)_o$ value should therefore be limited – in the diagram and for this example $(l/d)_{o,max} = 36$. Assuming $l_n = l_{ef}/k$, $f_{yk} = 500 \text{ N/mm}^2$ and $A_{s,prov} = A_{s,req}$ the minimum effective depth d_{min} is:

$$\frac{l_{ef}}{d} = Ks \frac{500}{f_{yk}} \frac{A_{s,prov}}{A_{s,req}} \left(\frac{l}{d} \right)_o \Rightarrow \frac{l_n}{d} = s \left(\frac{l}{d} \right)_o \Rightarrow d_{min} = \frac{l_n}{(l/d)_o s} \quad (1.6)$$

As stated before, Eqn (1.6) confirms that the governing bay in a continuous slab is the one characterized by the maximum normalized length, l_n .

1.5.1.2 Slab height determination

Identification of the slab height is an iterative process based on the successively better estimations of the (initially unknown) self-weight G_1 of the slab. A (safe) preliminary evaluation of slab self-weight G_1 may be based on the height calculated for the $\rho = \rho_o$ condition. For concrete class C25/30 Table 1.5.1 gives $\rho_o = 0,50\%$ then $(l/d)_o = 20$.

For the three different slab types the first trial minimum effective depths d_{min} for deflection control are:

Table 1.5.2 Minimum effective depth for deflection control

	$l_{ef,x}$	$l_{ef,y}$	l_{ef}	K	l_n	$(l/d)_0$	s	d_{min}
	m	m	m		m			m
Slab on beams	6,0	7,125	6,0	1,3	4,62	20	1,0	0,23
Flat slab	6,0	7,125	7,125	1,2	5,94	20	1,0	0,30
Slab with emb. el.	-	7,125	7,125	1,3	5,48	20	0,8	0,27

Due to the high reinforcement ratios ρ_0 , these effective depths d_{min} are no doubt conservative. On the basis of the conventional reinforced concrete unit weight (25 kN/m³) and the actual or “equivalent” (for ribbed or slabs with embedded lighting elements – see below) solid slab depth h (m):

$$G_1 = 25h \quad (\text{kN/m}^2)$$

For slabs with lighting embedded clay elements of width (38+12) cm with 5 cm concrete topping, the equivalent height results to be 51 ÷ 55% of the height of a solid slab (see Table 1.5.3) . As an example, if $h = 0,23$ m

$$G_1 = 25h = 25 \cdot (0,54 \cdot 0,23) = 3,10 \text{ kN/m}^2$$

Table 1.5.3 Equivalent height for slabs with lighting embedded elements

h_{le}	$h=h_{le} + 0,05$	G_1	$h_{eq} = G_1/25$	h_{eq} / h_{tot}
[m]	[m]	[kN/m ²]	[m]	
0,16	0,21	2,89	0,116	0,55
0,18	0,23	3,08	0,123	0,54
0,20	0,25	3,27	0,131	0,52
0,22	0,27	3,46	0,138	0,51
0,24	0,29	3,69	0,148	0,51

On the basis of the already determined $\phi_l = 14$ mm (SLS cracking), and $c_{nom} = 20$ mm:

- o for flat slabs with bars in X- and Y-direction

$$h = d_{min} + c_{nom} + \phi_l = d_{min} + 20 + 14 = (d_{min} + 34) \text{ mm}$$

- o for slabs with embedded lighting elements

$$h = d_{min} + c_{nom} + 1/2\phi_l = (d_{min} + 27) \text{ mm}$$

As the sustained permanent load G_2 is known, the total permanent load G is: $G = G_1 + G_2$. If the variable load Q and the related factor for the quasi-permanent (Q_p) load condition ψ_2 are known, an improved normalized slenderness ratio may be calculated with the formula:

$$\left(\frac{l_n}{d}\right) = \frac{\lambda_s}{\sqrt[3]{G + \psi_2 Q}} \quad (1.7)$$

The formula is based on SLS deformation, and the ULS design of simply supported slabs of “normalized span” l_n subjected to uniform loads G and Q . λ_s depends on the concrete class and the shape factor s only. Values for slabs are given in Table 1.5.4.

Table 1.5.4 λ_s for selected concrete classes

	C20/25	C25/30	C30/37	C35/45	C40/50
λ_s for $s = 1,0$	53	57	60	63	65
λ_s for $s = 0,8$	49	53	56	59	61

The iterative process can be easily implemented in an Excel™ spreadsheet, as outlined below. The reduction of the initial height is evident, two or three iterations are enough to identify the final height.

Table 1.5.5 Iterative reduction of the height

	d_{min}	$d_{min}+d'$	coeff	h_{eq}	G_1	G_2	Q_k	W_2	tot	I_s	L_r/d	I_n	d_{min}	
	m	m		m	kN/m ²	kN/m ²			kN/m				m	
1st iteration														
Slab on beams	0,23	0,26	1,00	0,26	6,62	3,0	2,0	0,30	10,22	57	26	4,62	0,18	-23%
Flat slab	0,30	0,33	1,00	0,33	8,27	3,0	2,0	0,30	11,87	57	25	5,94	0,24	-20%
Slab with l,el,	0,27	0,30	0,55	0,17	4,14	3,0	2,0	0,30	7,74	53	27	5,48	0,21	-25%
2nd iteration														
Slab on beams	0,18	0,21	1,00	0,21	5,26	3,0	2,0	0,30	8,86	57	27	4,62	0,17	-5%
Flat slab	0,24	0,27	1,00	0,27	6,82	3,0	2,0	0,30	10,42	57	26	5,94	0,23	-4%
Slab with l,el,	0,21	0,23	0,55	0,13	3,20	3,0	2,0	0,30	6,80	53	28	5,48	0,20	-4%
3rd iteration														
Slab on beams	0,17	0,20	1,00	0,20	5,06	3,0	2,0	0,30	8,66	57	28	4,62	0,17	-1%
Flat slab	0,23	0,26	1,00	0,26	6,56	3,0	2,0	0,30	10,16	57	26	5,94	0,23	-1%
Slab with l,el,	0,20	0,22	0,55	0,12	3,08	3,0	2,0	0,30	6,68	53	28	5,48	0,20	-1%

The height values so obtained, based as they are on the *Eurocode 2* equations, automatically guarantee the respect of SLS deformation and have not to be further checked.

CHAPTER 2

STRUCTURAL ANALYSES

Martin JUST and Manfred CURBACH

TU Dresden, Institute for concrete structures, Germany

2.1 Finite element modelling of the building

The example building is a six-storey building with two underground parking levels, described in 1.2.1, Chapter 1.

At the broad side there are three rows of columns (axes A, B, C (and D in levels -1 and -2)), in length there are six rows (axes 1 to 6). These columns support the slabs. Three different slab types (see Chapter 1) have been considered regarding the slabs:

- Flat slab with height $h = 21$ cm, directly supported by the columns
- Slab on beams, 2 spans, $h = 18$ cm, loads flow through beams into columns
- Slabs with embedded lighting elements $h = 23$ cm, loads flow through the coffered ceiling beams into supporting beams, which lead into the columns

Figure 2.1.1 shows the finite element model of the building, modelled with SoFiSTiK® software:

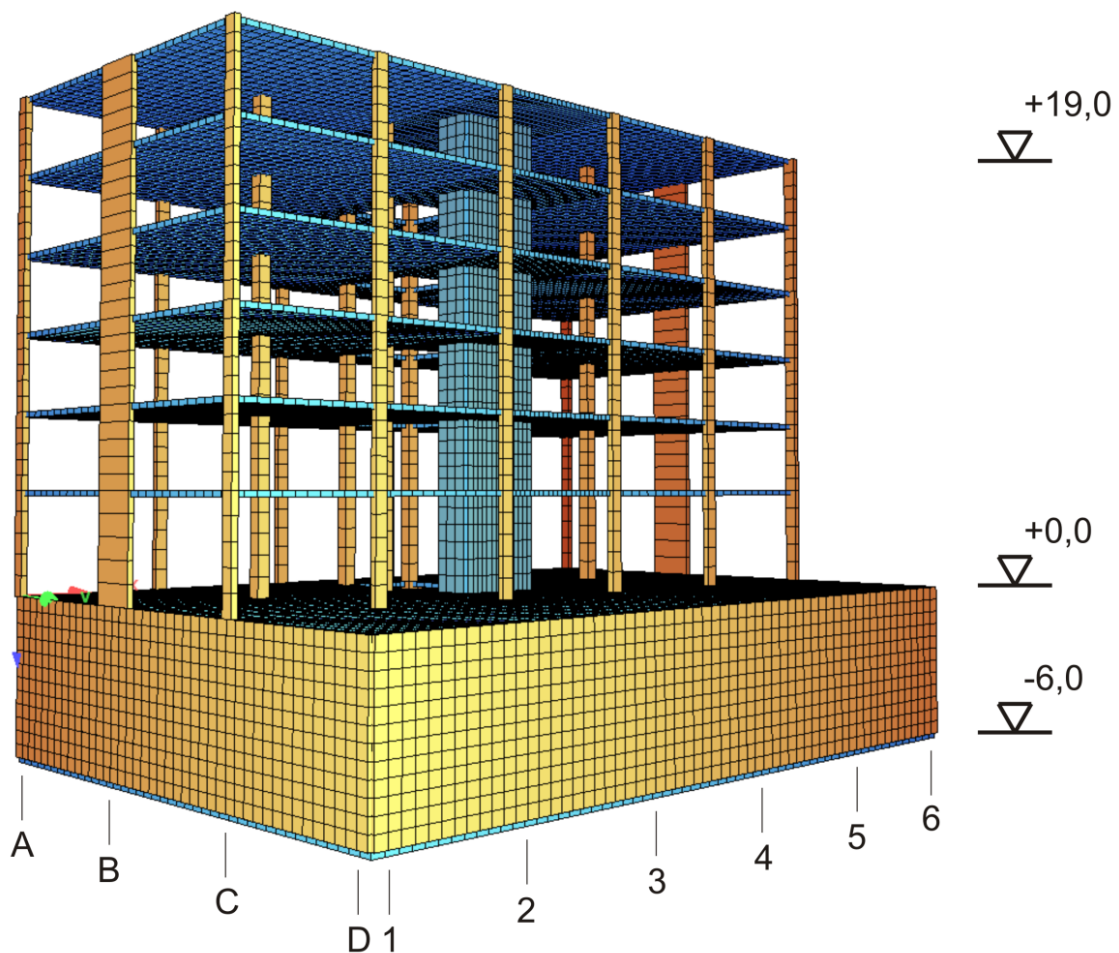

Fig.2.1.1 Finite element model of the building (type flat slab)

2.2 Loads, load cases and their combinations

2.2.1. Loads

Several multiple loads are present: the dead load of the construction, the interior (finishing, pavement, etc.) and the facade, service loads and two environmental loads – wind and snow. The following tables list the loads, their classes and the factors for combination:

Table 2.2.1 Loads

Class	Load name	Value of load	ψ_0	ψ_2
Dead load	dead load of construction	Variable values		
	dead load of interior	3,0 kN/m ²	-	
	dead load of facade	8,0 kN/m		
Environmental Load 1	wind (below 1000m above sea level)	0,77 kN/m ² below 10 m 1,09 kN/m ² at 19 m between 10 m and 19 m linear rising	0,6	0
Environmental Load 2	snow on roof or external area	1,70 kN/m ²	0,5	0
Service Load 1	dwelling (level 1-6)	2,00 kN/m ²	0,7	0,3
	stairs, office (level 0)	4,00 kN/m ²		
Service Load 2	parking (level -1, -2, external area)	2,50 kN/m ²	0,7	0,6

2.2.2. Load cases for dead loads

2.2.2.1 Load case 1 – dead load of the bearing structure

Dead loads of the structure are automatically calculated by FEM-Software on the basis of the geometry and unit weight of materials. Figure 2.2.1 shows the dead load for one storey.

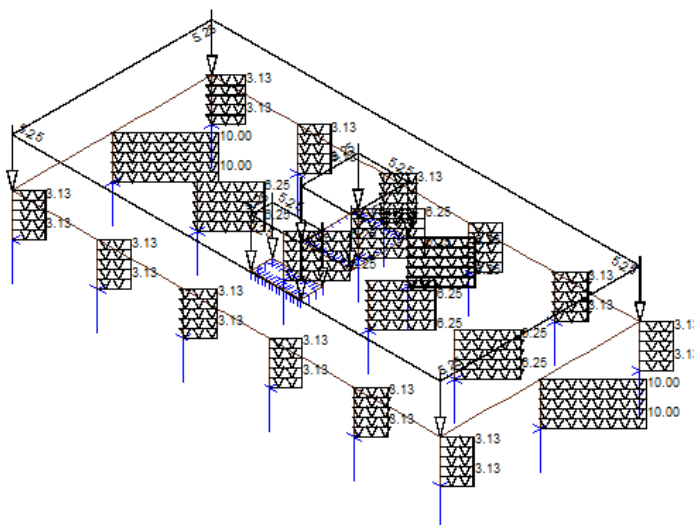

Fig.2.2.1 Calculated dead load (values in kN/m and KN/m²)

2.2.2.2 Load case 2 – dead load of the interior

The dead load of the interior is modelled in load case 2. Therefore an area load is set on all plate elements. Figure 2.2.2 shows the dead load for one storey.

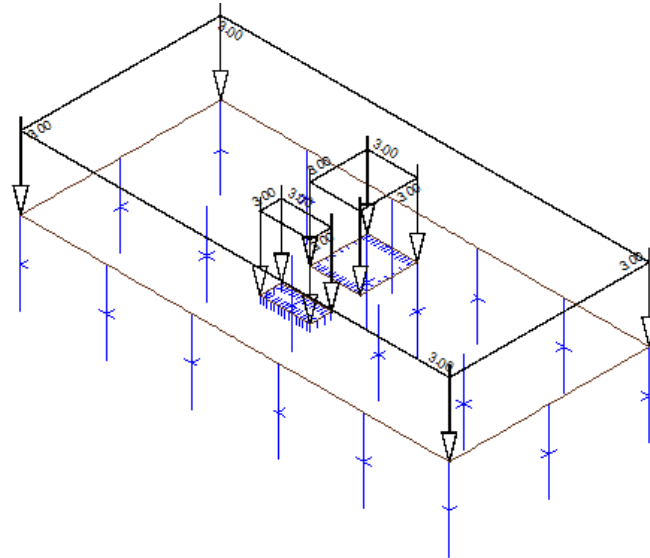

Fig 2.2.2 Dead load of the interior (values in KN/m²)

2.2.2.3 Load case 3 – dead load of the facade

In load case 3 the dead loads from the facade are modelled. In slab types a) and b) the loads are area set on the outer row of finite elements of the slabs, which have a size of (0,5 x 0,5) m, and a load value of 16 kN/m².

In slab type c) they are set on the outer beams as line loads. In this case, the load value is as given in Table 2.2.1. Figure 2.2.3 shows the dead load for one storey for type a).

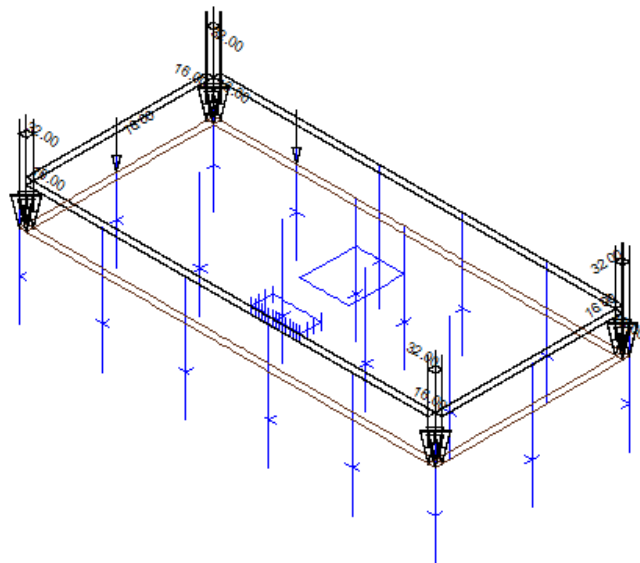

Fig.2.2.3 Dead load of the facade (values in KN/m²)

2.2.3. Load cases for wind, snow and service loads 1 and 2

2.2.3.1 Load case 51

Load case 51 contains the loads from wind in global X-direction of the building (parallel to the longer side). The loads are set on the columns, therefore the area loads have been converted to line loads. The facade is assumed to carry the loads as a two-span girder to the columns. Figure 2.2.4 shows the resulting loads.

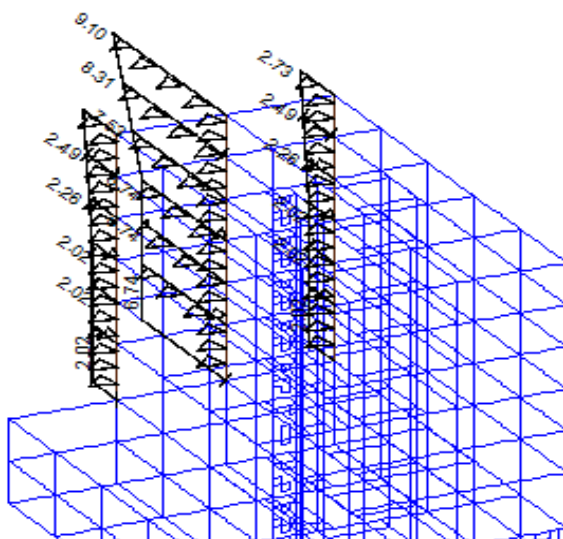

Fig.2.2.4 Arrangement of the loads for load case 51 (values in kN/m)

2.2.3.2 Load case 101

Load case 101 contains the loads from wind in global Y-direction of the building (perpendicular to the longer side). As in load case 51 loads are set on the columns and therefore the surface loads are converted to line loads. The facade is assumed to carry the loads as a six-span girder to the columns.

Figure 2.2.5 shows the resulting loads.

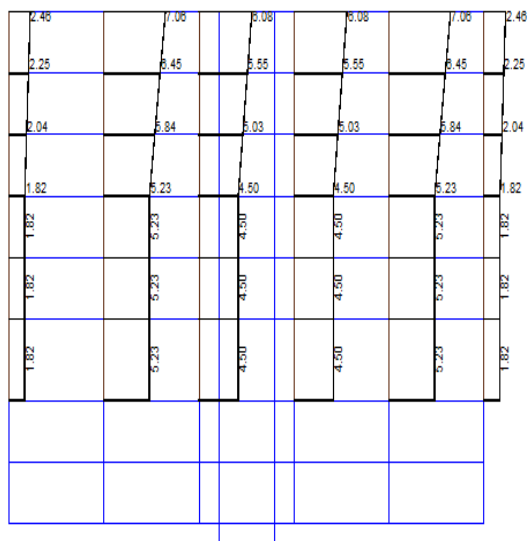

Fig.2.2.5 Arrangement of the loads for load case 101 (values in kN/m)

2.2.3.3 Load case 201

In load case 201 the snow on the roof is modelled as an area load on all plate elements of the roof slab as shown in Figure 2.2.6.

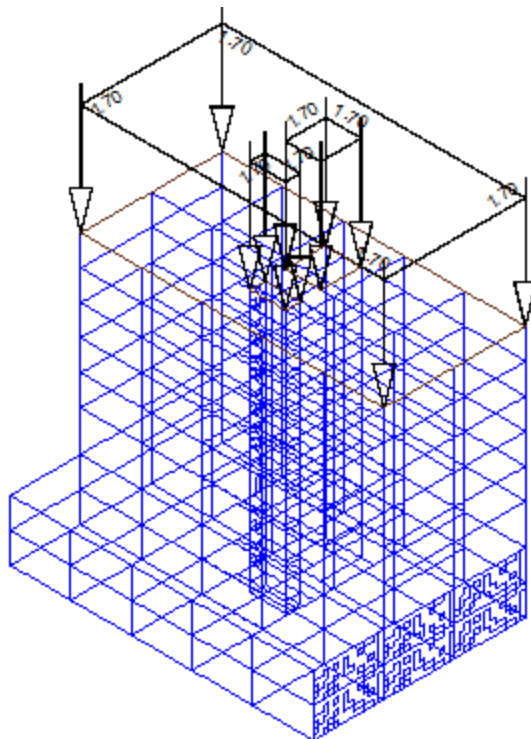

Fig.2.2.6 – Arrangement of the loads for load case 201 (values in kN/m²)

2.2.3.4 Load cases 202 to 206

Load cases 202 to 206 contain the field by field snow loads on the external area. In load case 202 the load is set on the field between axes 1 and 2, in 203 between 2 and 3 and so on. The arrangement of the snow loads for load case 202 is shown in Figure 2.2.7.

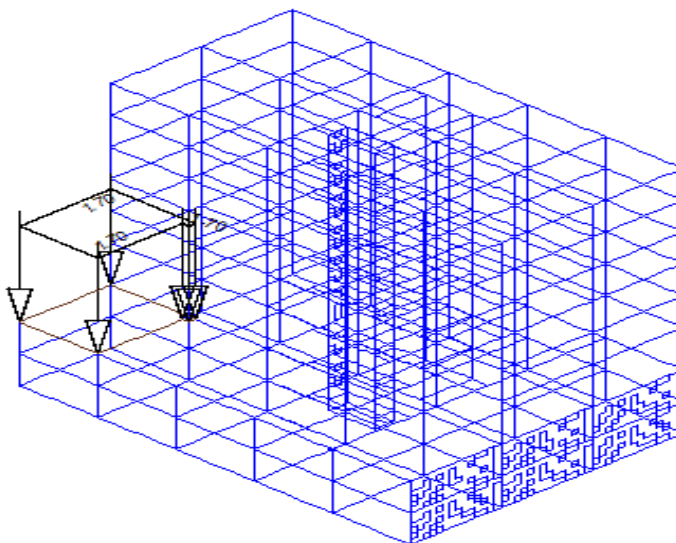

Fig.2.2.7 Arrangement of the loads for load case 202 (values in kN/m²)

2.2.3.5 Load cases 1326, 1336, 1356 and 1366

Load cases 1326, 1336, 1356 and 1366 contain the service load 1 on the roof in variable arrangements, as in the following figures. Figure 2.2.8 shows a combination chosen to maximize moment and shear action effects in the beam along axis 2, Figure 2.2.9 - a combination where all fields are loaded and Figure 2.2.10 shows a combination to maximize bi-axial moments in the columns.

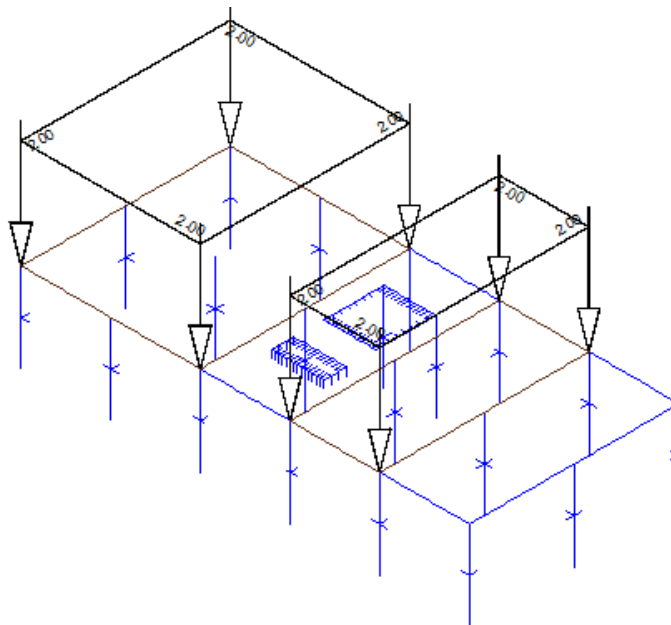

Fig.2.2.8 Arrangement of the loads for load case 1326 (values in kN/m)

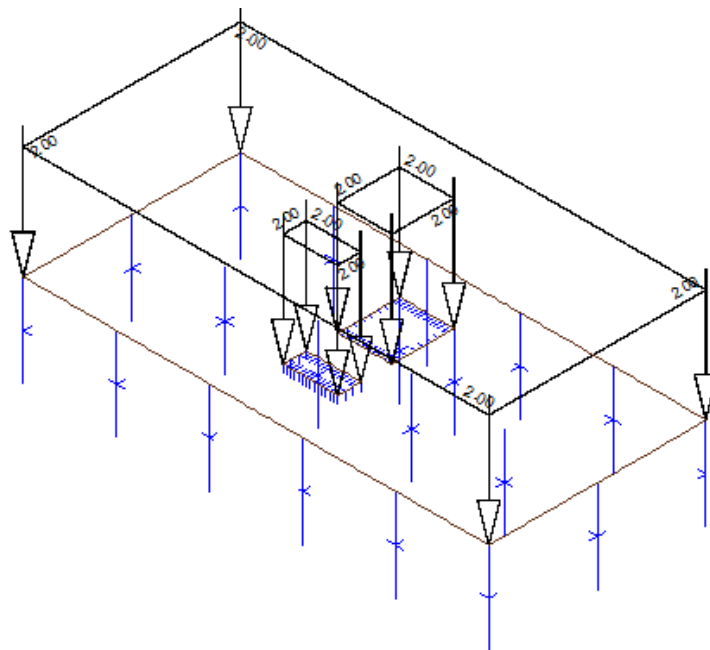

Fig.2.2.9 Arrangement of the loads for load case 1336 (values in kN/m)

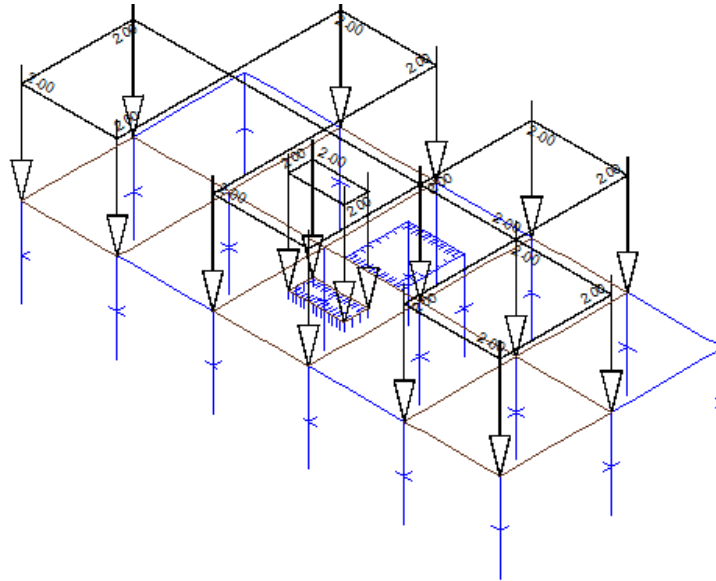

Fig.2.2.10 – Arrangement of the loads for load case 1356 (values in kN/m)

Figure 2.2.11 shows a combination chosen to maximize moment in field 2 of the beam in axis B.

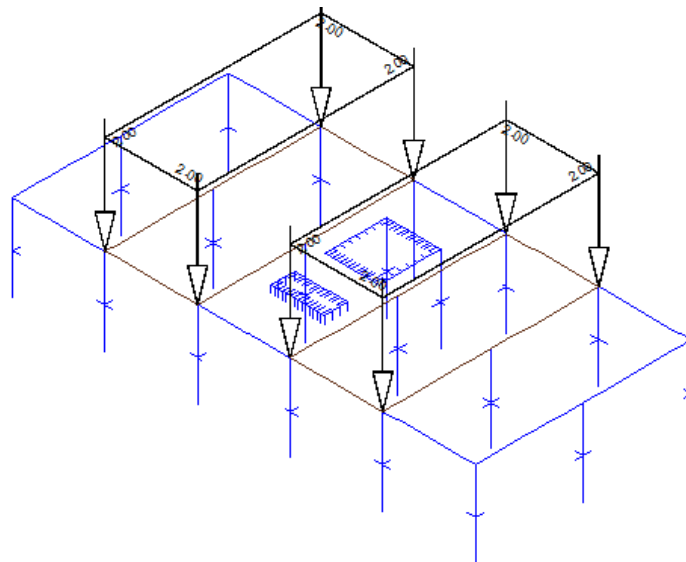

Fig.2.2.11 – Arrangement of the loads for load case 1366 (values in kN/m)

More combinations have been examined, but these were not governing the design.

2.2.3.6 Load cases 10001, 10011, 10021 and 10031

These load cases contain the service load 1 for the levels 0 to 5 in variable arrangements. Load case 10001 is similar to load case 1356. Levels 0, 2 and 4 have the arrangement as in Figure 2.2.10; levels 3 and 5 have the contrary arrangement.

Load case 10011 is similar to load case 1366. Levels 0, 2 and 4 have the same arrangement (Figure 2.2.11). The Levels 3 and 5 have the opposite arrangement (load on fields between axis 1 - 2, 3 - 4 and 5 - 6).

Load case 10021 is similar to load case 1326. All levels from 0 to 5 have the same arrangement, which is shown in Figure 2.2.8.

Load case 10031 equals load case 1336 – the load acts on all fields in all levels.

2.2.3.7 Load cases 10101, 10111, 10121 and 10131

These load cases contain the service load 2 for the levels -1 and -2 and for the external area in variable arrangements, which are the logical continuation of the arrangements from levels 0 ÷ 6. For example load case 10101 belongs to load case 10001.

The parking loads were set in their own load cases, because they have another exposure class than the loads from dwelling and offices, as shown in 2.2.1.

2.2.4. Rules for the combination of load cases

All dead load cases are assumed to act at every time. The load cases 51 and 101 are assumed to never act at the same time. The snow load cases 201 to 206 can act at the same time, if authoritative.

From load cases 1326, 1336, 1356 and 1366 only one can act at a time, this applies for 10001, 10011, 10021 and 10031, also for 10101, 10111, 10121 and 10131.

Furthermore one load case from 1326, 1336, 1356 and 1366 and one load case from 10001, 10011, 10021 and 10031 together have the predominant influence, because they are in the same class.

For the ultimate limit state (ULS) only one combination is calculated (general combination):

$$\gamma_G G \oplus \gamma_{Q,1} Q_1 \oplus \gamma_{Q,i} \Sigma(\psi_{0,i} Q_i) \quad (2.1)$$

with $\gamma_G = 1,35$ and $\gamma_{Q,1} = \gamma_{Q,i} = 1,5$.

For the serviceability limit states (SLS) the two following combinations are calculated:

- o characteristic combination:

$$G \oplus Q_1 \oplus \Sigma(\psi_{0,i} Q_i) \quad (2.2)$$

- o quasi permanent combination:

$$G \oplus \Sigma(\psi_{2,i} Q_i) \quad (2.3)$$

2.3 Internal forces and moments

2.3.1. Position of calculated internal forces and moments

2.3.1.1 Column B2

The internal forces for column B2 are calculated right above the foundation at the bottom end of the column. Also the values at the top of the column (in the parking level “-2”) that are linked to the values at the bottom end are calculated.

For the design of the foundation data are calculated at the sole of the foundation.

2.3.1.2 Shear wall B1

The internal forces for shear wall B1 are calculated at the bottom end of the wall (ground level).

2.3.1.3 Frame axis 2 – beam

The calculated internal forces and moments represent the beam in axis 2 on the 2nd floor for the slab type “Slab on beams.”

2.3.1.4 Frame axis B – beam

The calculated internal forces and moments represent the beam in axis B on the 2nd floor for the slab type “slab with embedded elements.” The results are only shown for the fields 1 to 3 (while 4 and 5 are mirrored results of 1 and 2).

2.3.1.5 Punching for flat slab

The given forces V_d are the design values that represent the shear forces which flow into the columns as normal forces at the columns A1 and B2. The values represent a flat slab situated in level 2.

2.3.2. Results of structural analysis

With the exception of punching (see 2.3.1.5) all internal forces and moments are calculated as characteristic values then combined in varying combinations as shown in 2.2.4. For each of these combinations, different superpositions have been calculated: Data units are [kN] and [m].

- The maximum internal moment M_y and the according values for internal forces N , V_y and V_z and for the internal moment M_z are calculated. This superposition is called “max M_y ”.
- The maximum internal moment M_z and the according values for internal forces N , V_y and V_z and for the internal moment M_y are calculated. This superposition is called “max M_z ”.
- The maximum internal force V_y and the according values for internal forces N and V_z and for the internal moments M_y and M_z are calculated. This superposition is called “max V_y ”.
- The maximum internal force V_z and the according values for internal forces N and V_y and for the internal moments M_y and M_z are calculated. This superposition is called “max V_z ”.
- The maximum internal force N and the according values for internal forces V_y and V_z and for the internal moments M_y and M_z are calculated. This superposition is called “max N ”.
- The minimum internal moment M_y and the according values for internal forces N , V_y and V_z and for the internal moment M_z are calculated. This superposition is called “min M_y ”.
- The minimum internal moment M_z and the according values for internal forces N , V_y and V_z and for the internal moment M_y are calculated. This superposition is called “min M_z ”.
- The minimum internal moment V_y and the according values for internal forces N and V_z and for the internal moments M_y and M_z are calculated. This superposition is called “min V_y ”.
- The minimum internal moment V_z and the according values for internal forces N and V_y and for the internal moments M_y and M_z are calculated. This superposition is called “min V_z ”.
- The minimum internal moment N and the according values for internal forces V_y and V_z and for the internal moments M_y and M_z are calculated. This superposition is called “min N ”.

In case of the flat slab, only the maximum shear force V_{Ed} at two columns has been calculated.

2.3.2.1 Column B2 - results for ULS and SLS

Results from the superposition in the ultimate limit state for the design of the column are in table 2.3.1. The combination is given in Eq. (2.1). The column local Y-axis equals the global X-axis parallel to the longer side of the building, the local Z-axis equals the (negative) global Y-axis perpendicular to the same side.

Tables 2.3.1 to 2.3.3 show the combined values for the bottom end of the column, tables 2.3.4 to 2.3.6 the related values for the top of the column in parking level “-2”.

Table 2.3.1 Results for column B2 (bottom end) - ULS

Superposition	N_d	$V_{y,d}$	$V_{z,d}$	$M_{y,d}$	$M_{z,d}$	Considered load cases	
	[kN]	[kN]	[kN]	[kNm]	[kNm]	Q_1	Q_i
max M_y	-4517,82	0,23	-4,05	4,21	-0,31	101	203 - 206, 1356, 10111
max M_z	-4827,82	4,46	1,88	-2,43	4,45	10111	51, 203- 206, 10011
max V_y	-4827,82	4,46	1,88	-2,43	4,45	10111	51, 203- 206, 10011
max V_z	-5139,33	-2,46	2,96	-3,62	-2,08	51	10031, 10101
max N	-4408,94	-1,83	2,27	-2,73	-1,38	51	202 – 205
min M_y	-5300,62	-2,48	2,96	-3,64	-2,12	51	201, 1326, 10031, 10101
min M_z	-5407,83	-4,65	-1,43	1,17	-4,85	10121	101, 201, 202, 1326, 10021
min V_y	-5358,27	-4,81	-1,46	-2,09	-4,70	10121	201, 202, 1356, 10021
min V_z	-4467,29	0,25	-4,05	4,20	-0,29	101	202- 206, 10111
min N	-5697,49	-4,53	1,54	-2,36	-4,49	10031 & 1336	201, 10121

Table 2.3.2 gives results from Superposition for serviceability limit states SLS. The first combination is given in Eqn. (2.2).

Table 2.3.2 Results for column B2 (bottom end) for SLS – characteristic combination

Superposition	N_d	$V_{y,d}$	$V_{z,d}$	$M_{y,d}$	$M_{z,d}$	Considered load cases	
	[kN]	[kN]	[kN]	[kNm]	[kNm]	Q_1	Q_i
max M_y	-3339,34	-0,10	-2,63	2,70	-0,45	101	203 - 206, 1356, 10111
max M_z	-3546,00	2,72	1,31	-1,73	2,72	10111	51, 203- 206, 10011
max V_y	-3546,00	2,72	1,31	-1,73	2,72	10111	51, 203- 206, 10011
max V_z	-3753,68	-1,89	2,04	-2,52	-1,63	51	10031, 10101
max N	-3266,75	-1,47	1,58	-1,93	-1,17	51	202 – 205
min M_y	-3861,20	-1,91	2,04	-2,53	-1,66	51	201, 1326, 10031, 10101
min M_z	-3932,68	-3,35	-0,89	0,67	-3,48	10121	101, 201, 202, 1326, 10021
min V_y	-3899,64	-3,46	1,04	-1,50	-3,38	10121	201, 202, 1356, 10021
min V_z	-3305,65	-0,08	-2,63	2,69	-0,44	101	202- 206, 10111
min N	-4125,78	-3,27	1,09	-1,68	-3,23	10031 & 1336	201, 10121

The second combination is given in Eqn. (2.3).

Table 2.3.3 Results for column B2 (bottom end) for SLS – quasi permanent combination

Superposition	N_d	$V_{y,d}$	$V_{z,d}$	$M_{y,d}$	$M_{z,d}$	Considered load cases	
	[kN]	[kN]	[kN]	[kNm]	[kNm]	Q_1	Q_i
max M_y	-3316,43	-0,60	0,63	-1,04	-0,60		1356, 10111
max M_z	-3419,06	1,28	0,68	-1,11	1,18		10011, 10111
max V_y	-3419,06	1,28	0,68	-1,11	1,18		10011, 10111
max V_z	-3482,90	-2,71	0,82	-1,31	-2,64		10031, 10101
max N	-	-	-	-	-		Not applicable
min M_y	-3526,55	-2,83	0,92	-1,39	-2,73		1326, 10031, 10101
min M_z	-3596,67	-3,32	0,95	-1,35	-3,16		1326, 10021, 10121
min V_y	-3582,47	-3,32	0,95	-1,35	-3,15		1356, 10021, 10121
min V_z	-3301,99	-0,59	0,63	-1,04	-0,60		10111
min N	-4075,03	-3,20	1,07	-1,66	-3,17		1336, 10031, 10121

The values for the design of the foundation equal those given above, but dead load of the foundation has been included.

The following tables give the values for the top of the column (in the parking level “-2”) corresponding to the superposition uses for the bottom end.

Table 2.3.4 Results for column B2 (top end) for ULS

Superposition	N_d	$V_{y,d}$	$V_{z,d}$	$M_{y,d}$	$M_{z,d}$	Considered load cases	
	[kN]	[kN]	[kN]	[kNm]	[kNm]	Q_1	Q_i
max M_y	-4492,51	0,23	-4,05	-7,92	0,60	101	203 - 206, 1356, 10111
max M_z	-4802,51	4,46	1,88	3,18	-8,95	10111	51, 203- 206, 10011
max V_y	-4802,51	4,46	1,88	3,18	-8,95	10111	51, 203- 206, 10011
max V_z	-5114,02	-2,46	2,96	5,28	5,24	51	10031, 10101
max N	-4383,62	-1,83	2,27	4,10	4,05	51	202 – 205
min M_y	-5275,31	-2,48	2,96	5,28	5,28	51	201, 1326, 10031, 10101
min M_z	-5382,52	-4,65	-1,43	-3,10	10,09	10121	101, 201, 202, 1326, 10021
min V_y	-5332,96	-4,81	1,46	2,32	9,75	10121	201, 202, 1356, 10021
min V_z	-4441,97	0,25	-4,05	-7,93	0,56	101	202- 206, 10111
min N	-5672,18	-4,53	1,54	2,30	9,13	10031 & 1336	201, 10121

Results from Superposition for serviceability limit state. The first combination is given in Eqn. (2.2).

Table 2.3.5 Results for column B2 (top end) for SLS – characteristic combination

Superposition	N_d	$V_{y,d}$	$V_{z,d}$	$M_{y,d}$	$M_{z,d}$	Considered load cases	
	[kN]	[kN]	[kN]	[kNm]	[kNm]	Q_1	Q_i
max M_y	-3320,59	-0,10	-2,63	-5,20	0,91	101	203 - 206, 1356, 10111
max M_z	-3527,25	2,72	1,31	2,20	-5,45	10111	51, 203- 206, 10011
max V_y	-3527,25	2,72	1,31	2,20	-5,45	10111	51, 203- 206, 10011
max V_z	-3734,93	-1,89	2,04	3,61	4,01	51	10031, 10101
max N	-3248,00	-1,47	1,58	2,82	3,22	51	202 – 205
min M_y	-3842,45	-1,91	2,04	3,61	4,04	51	201, 1326, 10031, 10101
min M_z	-3913,93	-3,35	-0,89	-1,98	7,24	10121	101, 201, 202, 1326, 10021
min V_y	-3880,89	-3,46	1,04	1,63	7,01	10121	201, 202, 1356, 10021
min V_z	-3286,90	-0,08	-2,63	-5,20	0,89	101	202- 206, 10111
min N	-4107,03	-3,27	1,09	1,62	6,60	10031 & 1336	201, 10121

The second combination is given in Eqn. (2.3).

Table 2.3.6 Results for column B2 (top end) for SLS – quasi permanent combination

Superposition	N_d	$V_{y,d}$	$V_{z,d}$	$M_{y,d}$	$M_{z,d}$	Considered load cases	
	[kN]	[kN]	[kN]	[kNm]	[kNm]	Q_i	
max M_y	-3297,68	-0,60	0,63	0,85	1,19	1356, 10111	
max M_z	-3400,31	1,28	0,68	0,93	-2,66	10011, 10111	
max V_y	-3400,31	1,28	0,68	0,93	-2,66	10011, 10111	
max V_z	-3464,15	-2,71	0,82	1,17	5,49	10031, 10101	
max N	-	-	-	-	-	Not applicable	
min M_y	-3507,80	-2,83	0,92	1,38	5,74	1326, 10031, 10101	
min M_z	-3577,92	-3,32	0,95	1,49	6,83	1326, 10021, 10121	
min V_y	-3563,72	-3,32	0,95	1,50	6,83	1356, 10021, 10121	
min V_z	-3283,24	-0,59	0,63	0,84	1,18	10111	
min N	-4065,28	-3,20	1,07	1,56	6,43	1336, 10031, 10121	

2.3.2.2 Shear wall B1, results for ULS and SLS

Results from the ULS superposition for the design of the column.

The combination is given in Eqn. (2.1). Figure 2.3.1 shows as an example the superposition for the shear wall for “max M_z ”.

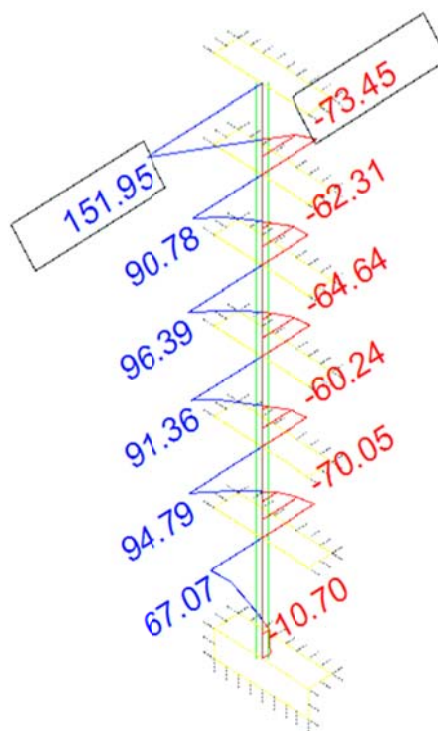

Fig.2.3.1 – Superposition “max M_z ” in ULS

Note: The local Y-axis of the column equals the global X-axis, parallel to the longer side of the building. The local Z-axis of the column equals the (negative) global Y-axis, perpendicular to the same side.

Table 2.3.7 Results for Shear Wall B1 (Bottom End) for ULS

Superposition	N_d	$V_{y,d}$	$V_{z,d}$	$M_{y,d}$	$M_{z,d}$	Considered load cases	
	[kN]	[kN]	[kN]	[kNm]	[kNm]	Q_1	Q_i
max M_y	-2392,60	-22,90	10,17	66,59	-35,53	101	10021
max M_z	-2190,99	3,16	11,44	-29,59	-10,75	51	1336, 10111
max V_y	-2143,66	3,21	11,57	-29,44	-10,73	51	203, 10111
max V_z	-2178,68	-18,13	12,01	65,73	-25,93	101	205, 1356 ,10131
max N	-2143,70	2,85	10,91	-29,24	-11,78	51	-
min M_y	-2338,46	0,73	10,39	-30,71	-15,60	51	201, 205 ,206, 1336, 10001, 10131
min M_z	-2493,57	-24,85	7,69	38,22	-39,31	1366 & 10031	101
min V_y	-2523,28	-24,88	7,64	38,61	-39,34	1366 & 10021	101, 201
min V_z	-2353,11	-21,59	3,94	-5,27	-32,94	1366 & 10001	-
min N	-2591,47	-24,54	5,40	-3,55	-38,32	1326 & 10021	201, 10121

Results from the superposition for the SLS.

The first combination is given in Eqn. (2.2).

Table 2.3.8 Results for shear wall B1 (bottom end) for SLS – characteristic combination

Superposition	N_d	$V_{y,d}$	$V_{z,d}$	$M_{y,d}$	$M_{z,d}$	Considered load cases	
	[kN]	[kN]	[kN]	[kNm]	[kNm]	Q_1	Q_i
max M_y	-1754,69	-16,62	7,23	44,11	25,64	101	10021
max M_z	-1620,29	0,76	8,08	-20,41	-9,11	51	1336, 10111
max V_y	-1588,74	0,79	8,17	-19,91	-9,10	51	203, 10111
max V_z	-1612,08	-13,43	8,46	43,54	-19,23	101	205, 1356 ,10131
max N	-1588,76	0,55	7,73	-19,78	-9,80	51	-
min M_y	-1718,61	-0,86	7,38	-20,76	-12,35	51	201, 205 ,206, 1336, 10001, 10131
min M_z	-1822,01	-17,91	5,58	25,19	-28,16	1366 & 10031	101
min V_y	-1841,82	-17,93	5,55	25,45	-28,18	1366 & 10021	101, 201
min V_z	-1728,37	-15,74	3,08	-3,80	-23,91	1366 & 10001	-
min N	-1887,27	-17,71	4,06	-2,65	-27,50	1326 & 10021	201, 10121

The second combination is given in Eqn. (2.3).

Table 2.3.9 Results for shear wall B1 (bottom end) for SLS – quasi permanent combination

Superposition	N_d	$V_{y,d}$	$V_{z,d}$	$M_{y,d}$	$M_{z,d}$	Considered load cases	
	[kN]	[kN]	[kN]	[kNm]	[kNm]	Q_i	
max M_y	-1664,22	-14,79	4,31	-2,72	-22,04	10021	
max M_z	-1609,81	-13,30	4,87	-3,01	-18,92	1336, 10111	
max V_y	-1596,30	-13,29	4,89	-2,96	-18,92	10011	
max V_z	-1603,16	-13,36	5,05	-3,03	-19,09	1356, 10131	
max N	-1596,29	-13,49	4,55	-2,85	-19,50	-	
min M_y	-1643,80	-14,02	4,63	-3,31	-20,39	1336, 10001, 10131	
min M_z	-1664,02	-14,80	4,27	-2,83	-22,06	1336, 10031	
min V_y	-1664,02	-14,80	4,27	-2,74	-22,07	1366, 10021	
min V_z	-1630,17	-14,16	4,12	-3,12	-20,82	1366, 10001	
min N	-1677,96	-14,66	4,60	-2,85	-21,63	1326, 10021, 10121	

2.3.2.3 Frame axis 2 – beam, results for ULS

Figures 2.3.2 and 2.3.3 show the results for the superposition of “max M_y ”:

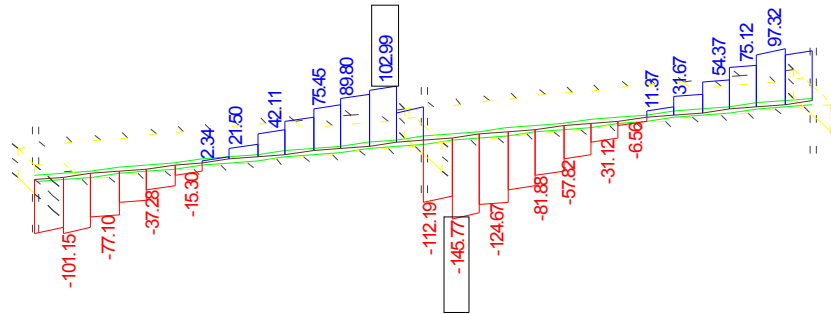

Fig.2.3.2 V_z values for the superposition of "max M_y "

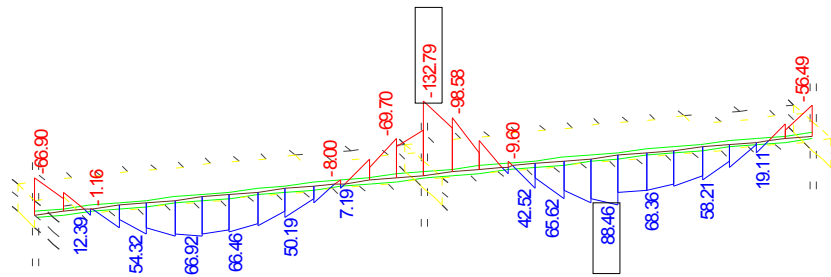

Fig.2.3.3 M_y values for the superposition of "max M_y "

For the superposition of "min M_y ", two cases have been considered. The first one is the minimum internal moment at the end support; the second is the minimum internal moment at the middle support. This was necessary to reduce the data output, because the file size of FEM-results grew too big otherwise.

Figures 2.3.4 and 2.3.5 show the results for the superposition of "min M_y " for end support:

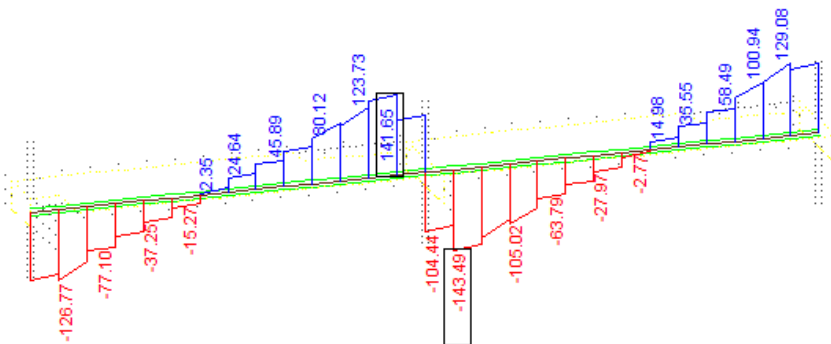

Fig.2.3.4 V_z values for superposition "min M_y "

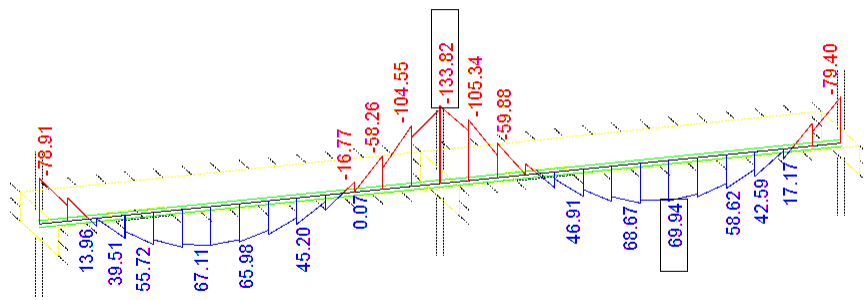

Fig.2.3.5 M_y values for the superposition of “min M_y ”

Figures 2.3.6 and 2.3.7 show the results for the superposition of “min M_y ” for the middle support:

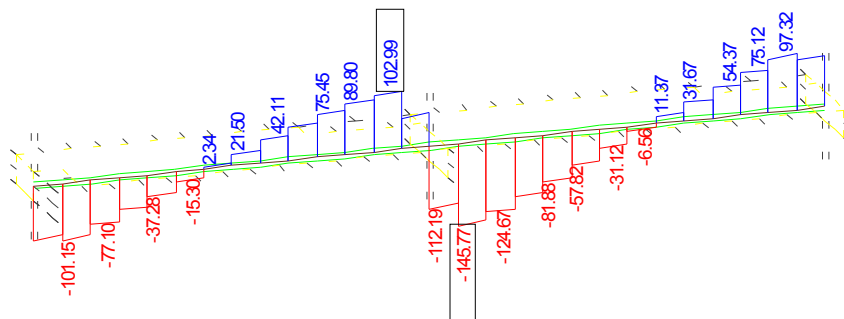

Fig.2.3.6 V_z values for the superposition of “min M_y ”

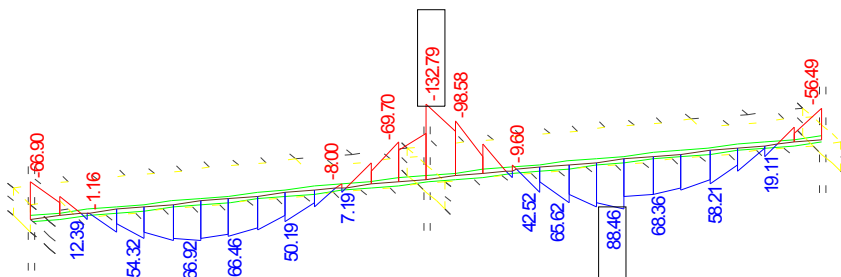

Fig.2.3.7 Values for M_y for the superposition of “min M_y ”

Figures 2.3.8 and 2.3.9 show the results for the superposition of “max V_z ” for shear forces at the end support:

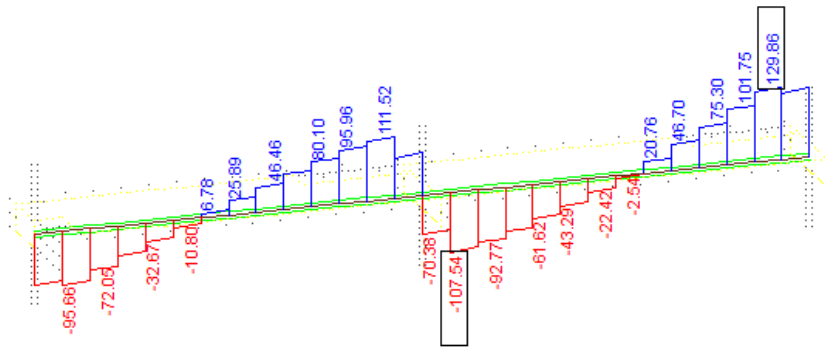

Fig.2.3.8 Values for V_z for the superposition of “max V_z ”

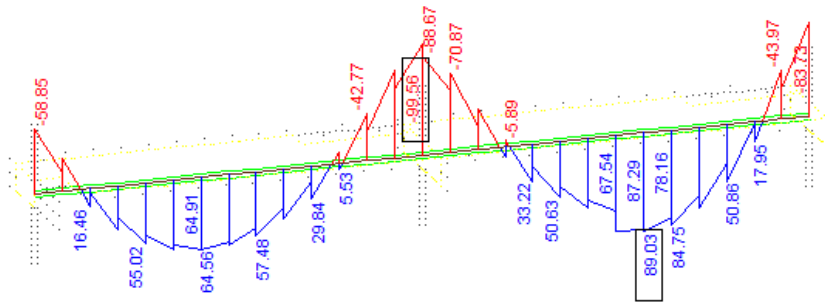

Fig.2.3.9 Values for M_y for the superposition of “max V_z ”

Figures 2.3.10 and 2.3.11 show the results for the superposition of “min V_z ” for shear forces at the middle support:

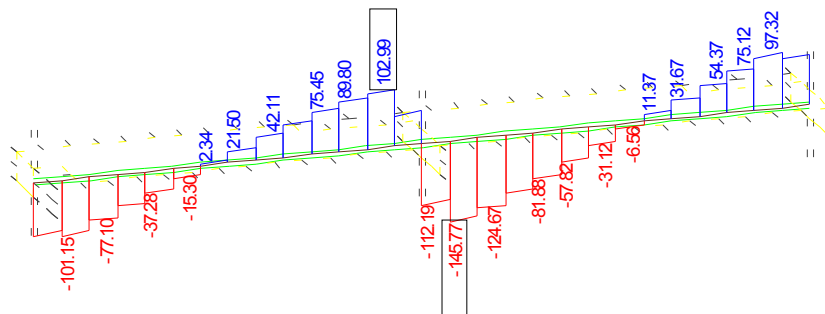

Fig.2.3.10 Values for V_z for the superposition of “min V_z ”

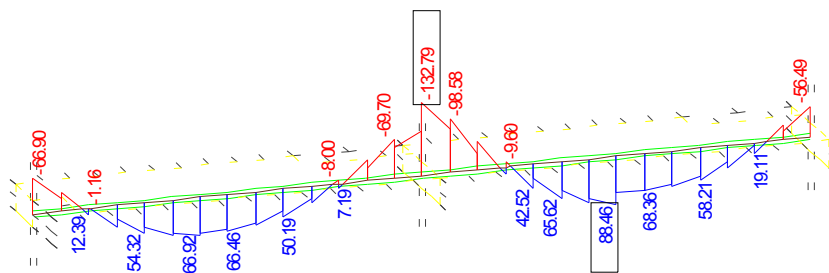

Fig.2.3.11 Values for M_y for the superposition of “min V_z ”

2.3.2.4 Frame axis B – Beam, results for ULS

For the superposition of “max M_y ”, two cases have been considered. The first case is the maximum internal moment in field one, the second is the maximum internal moment in the second field. This was necessary to reduce the data output, because the file size of FEM-results grew too big otherwise.

Figures 2.3.12 and 2.3.13 show the results for the superposition of “max M_y ” for the first field:

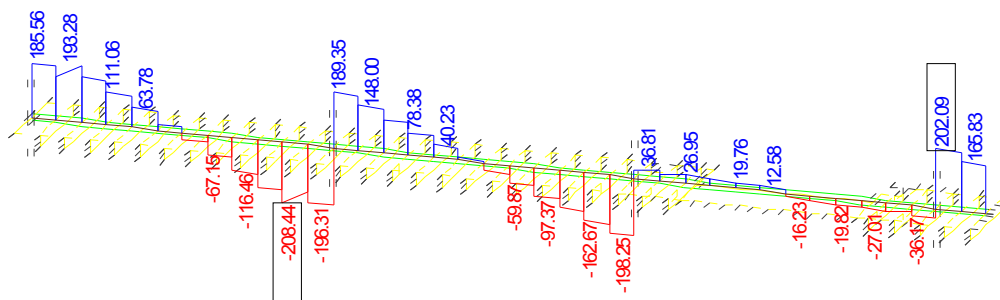

Fig.2.3.12 Values for V_z for the superposition of “max M_y ”

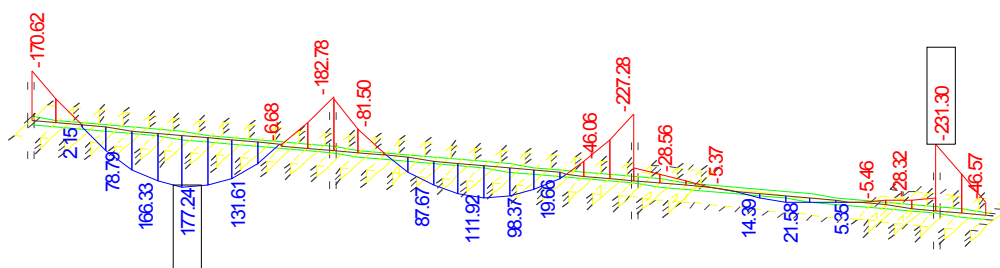

Fig.2.3.13 Values for M_y for the superposition of “max M_y ”

Figures 2.3.14 and 2.3.15 show the results for the superposition of “max M_y ” for the second field:

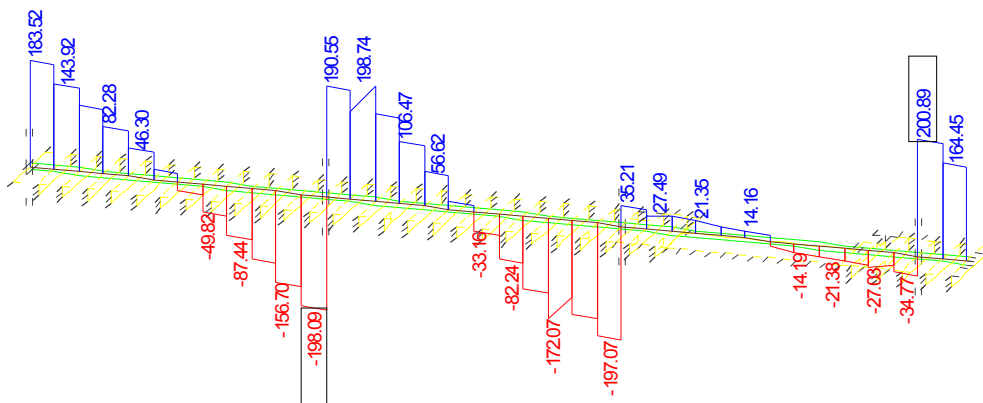

Fig.2.3.14 Values for V_z for the superposition of “max M_y ”

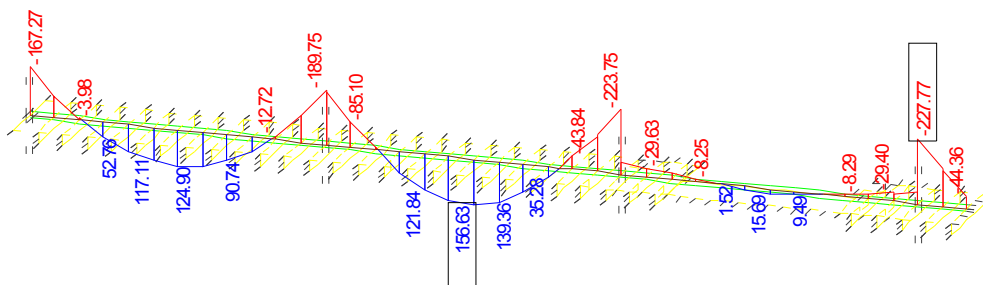

Fig.2.3.15 Values for M_y for the superposition of “max M_y ”

For the superposition of “min M_y ”, three cases have been considered. The first case is the minimum internal moment at the end support, the second is the minimum internal moment at the first internal support and the third is the minimum internal moment at the second internal support. This was necessary to reduce the data output, because the file size of FEM-results grew too big otherwise.

Figures 2.3.16 and 2.3.17 show the results for the superposition of “min M_y ” for the end support:

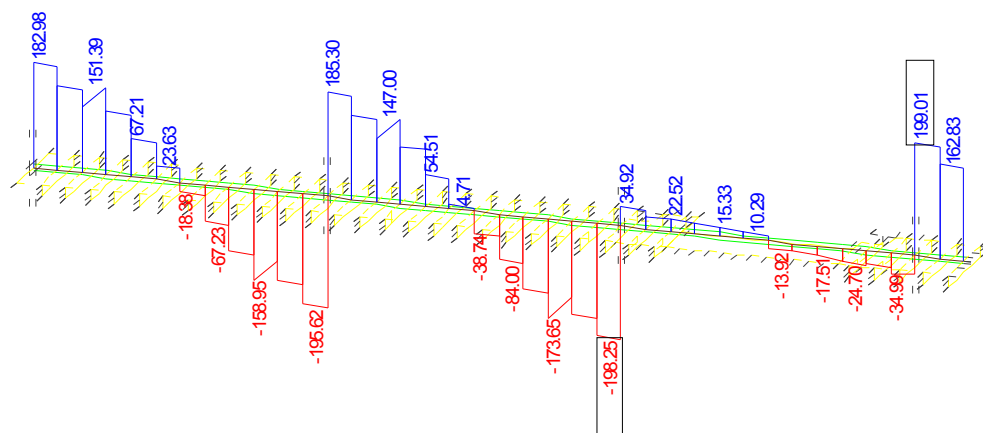

Fig.2.3.16 Values for V_z for the superposition of “min M_y ”

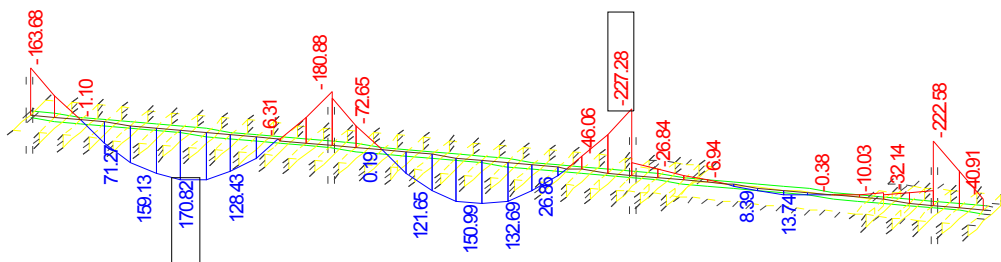

Fig.2.3.17 Values for M_y for the superposition of "min M_y "

Figures 2.3.18 and 2.3.19 show the results for the superposition of "min M_y " for the first internal support:

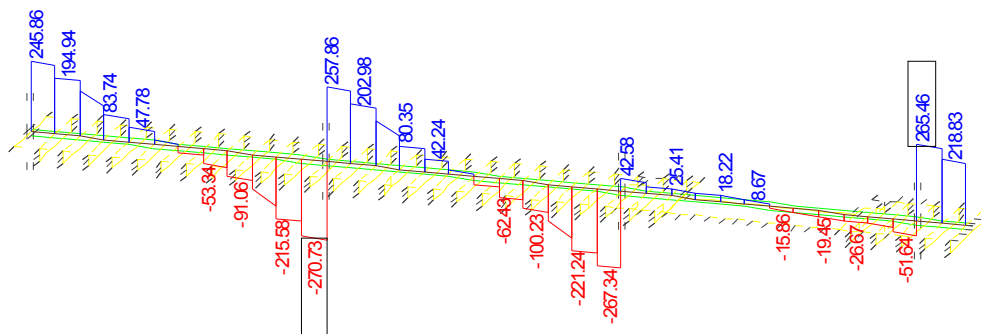

Fig.2.3.18 Values for V_z for the superposition of "min M_y "

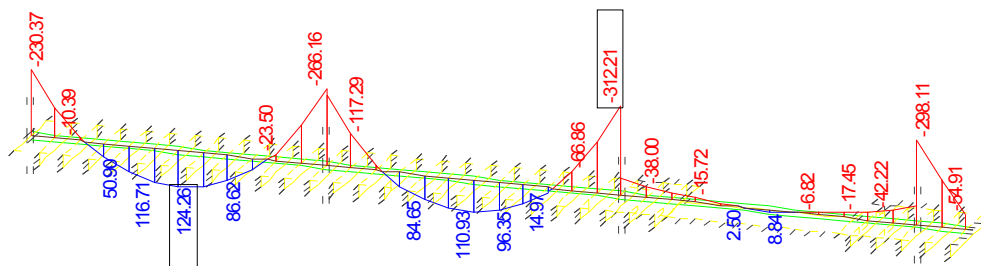

Fig.2.3.19 Values for M_y for the Superposition of "min M_y "

Figures 2.3.19 and 2.3.20 show the results for the superposition of "min M_y " for the second internal support:

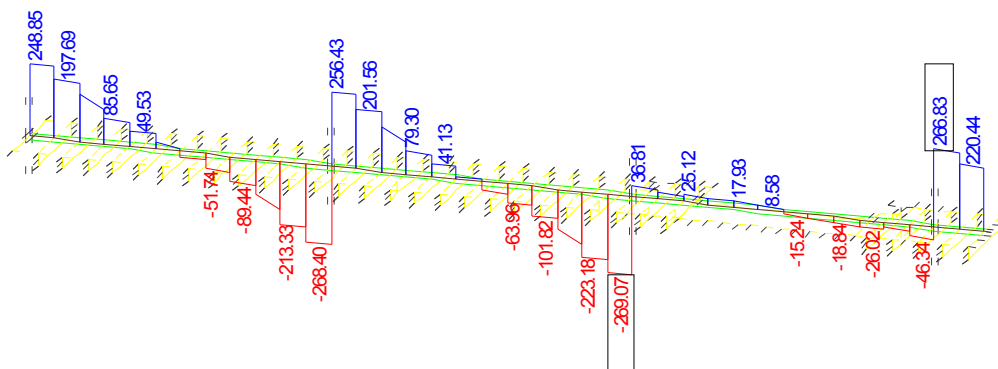

Fig.2.3.19 Values for V_z for the superposition of “min M_y ”

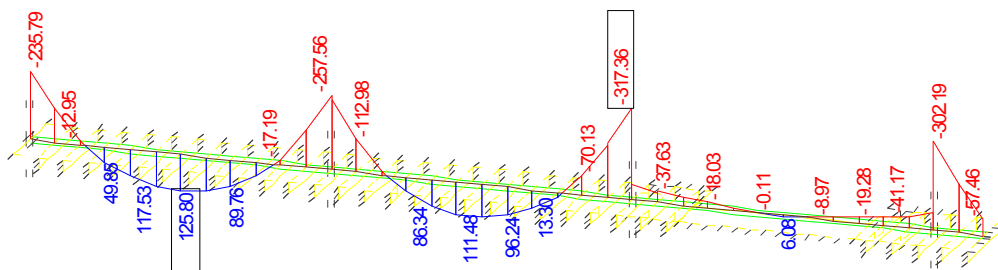

Fig.2.3.20 Values for M_y for the superposition of “min M_y ”

Figures 2.3.21 and 2.3.22 show the results for the superposition of “max V_z ” for the end support:

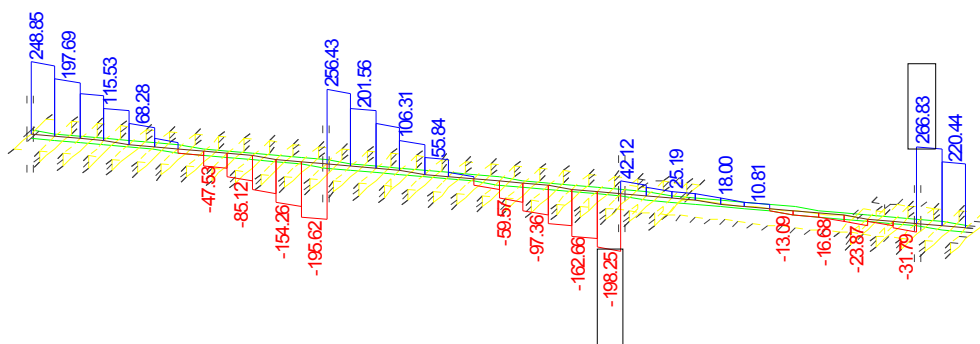

Fig.2.3.21 Values for V_z for the superposition of “max V_z ”

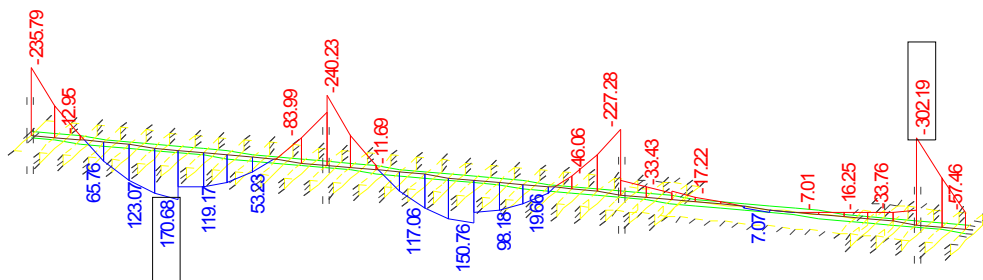

Fig.2.3.22 Values for M_y for the superposition of “max V_z ”

Figures 2.3.23 and 2.3.24 show the results for the superposition of “min V_z ” for the first internal support:

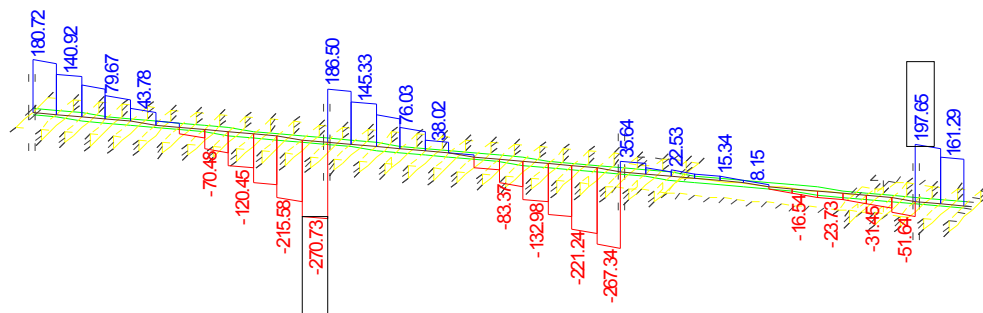

Fig.2.3.23 Values for V_z for the superposition of “min V_z ”

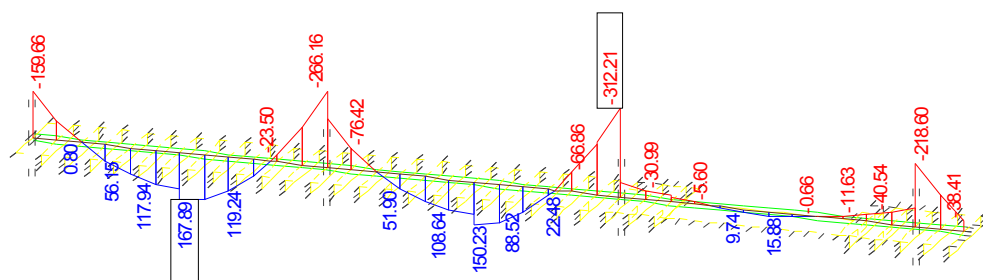

Fig.2.3.24 Values for M_y for the superposition of “min V_z ”

Figures 2.3.25 and 2.3.26 show the results for the superposition of “min V_z ” for the second internal support:

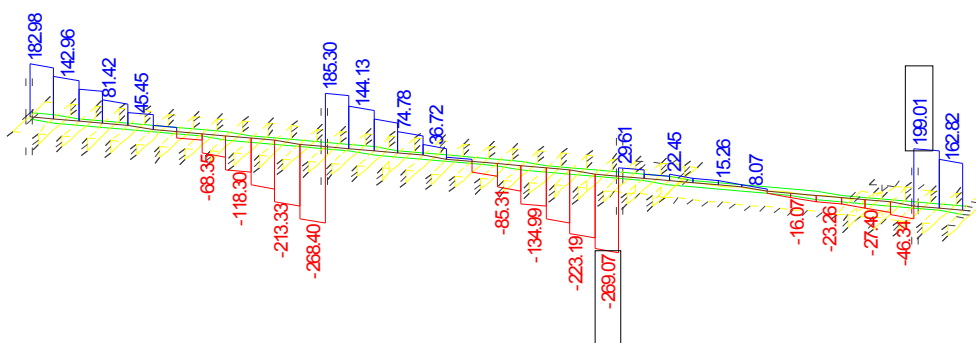

Fig.2.3.25 Values for V_z for the superposition of “min V_z ”

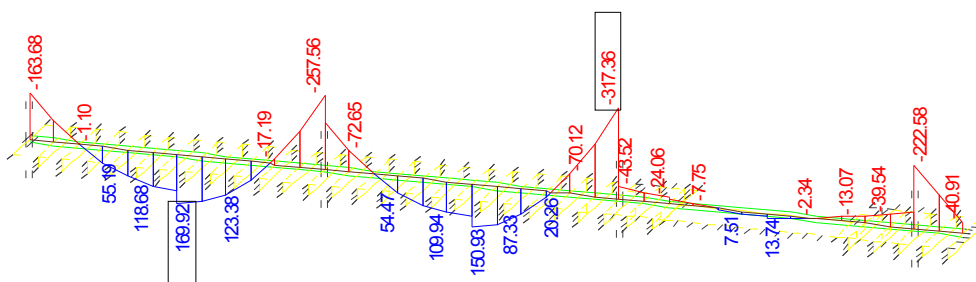

Fig.2.3.26 Values for M_y for the superposition of “min V_z ”

2.3.2.5 Punching for flat slab, results for ULS

Results from the superposition for the ultimate limit state are in Table 2.3.10. The combination is given in Eqn. (2.1).

Table 2.3.10 Flat Slab - shear forces at columns A1 and B2

Position	V_d [kN]	Considered load cases	
		Q_1	Q_i
A1	176,48	10021	1356, 201
B2	693,02	10021	202, 101

The serviceability limit states action effects have not been considered for the flat slab.

CHAPTER 3

LIMIT STATE DESIGN (ULS - SLS)

Just WALRAVEN¹ and Sausanne GMAINER²

¹Delft University of Technology, The Netherlands

²Vienna University of Technology, Austria

3.1 Introduction

3.1.1. Motivation

The aim of this paper is the design of a six-storey building with two underground parking levels according to *Eurocode 2*. The building is described in details in 1.2.1, Chapter 1. The view of the ground floor and the main sections of the building are given and shown in Figure 3.1.1 and Figure 3.1.2.

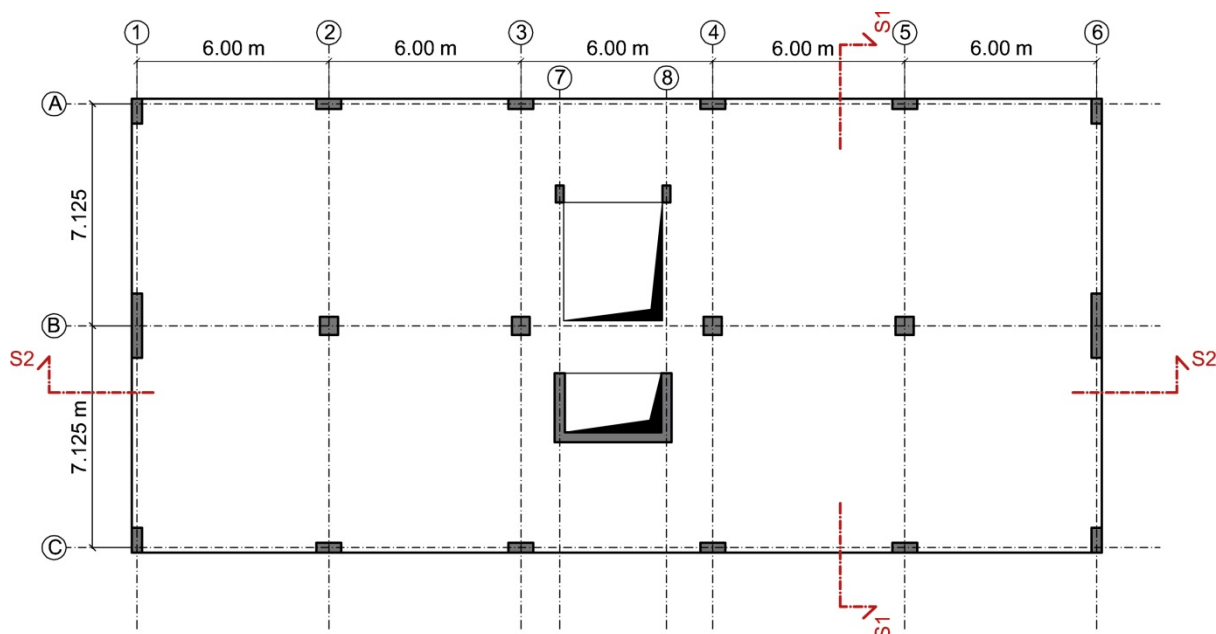

Fig. 3.1.1 View of the building in plan

On the basis of the effects of the actions from the structural analysis (Chapter 2), the following consider the ultimate limit state for typical bending, shear, axial and punching cases in design procedures. To satisfy also the serviceability limit state criteria the calculation for limiting the crack width and the deflection for the critical members are presented.

Three different types of horizontal slabs are considered:

- Slabs on beams ($h_{slab} = 0,18$ m, $h_{beam} = 0,40$ m)
- Flat slab ($h = 0,21$ m)
- Slabs with embedded lighting elements ($h = 0,23$ m, T-beams: $h = 0,40$ m)

Furthermore the verification for the columns and walls is carried out.

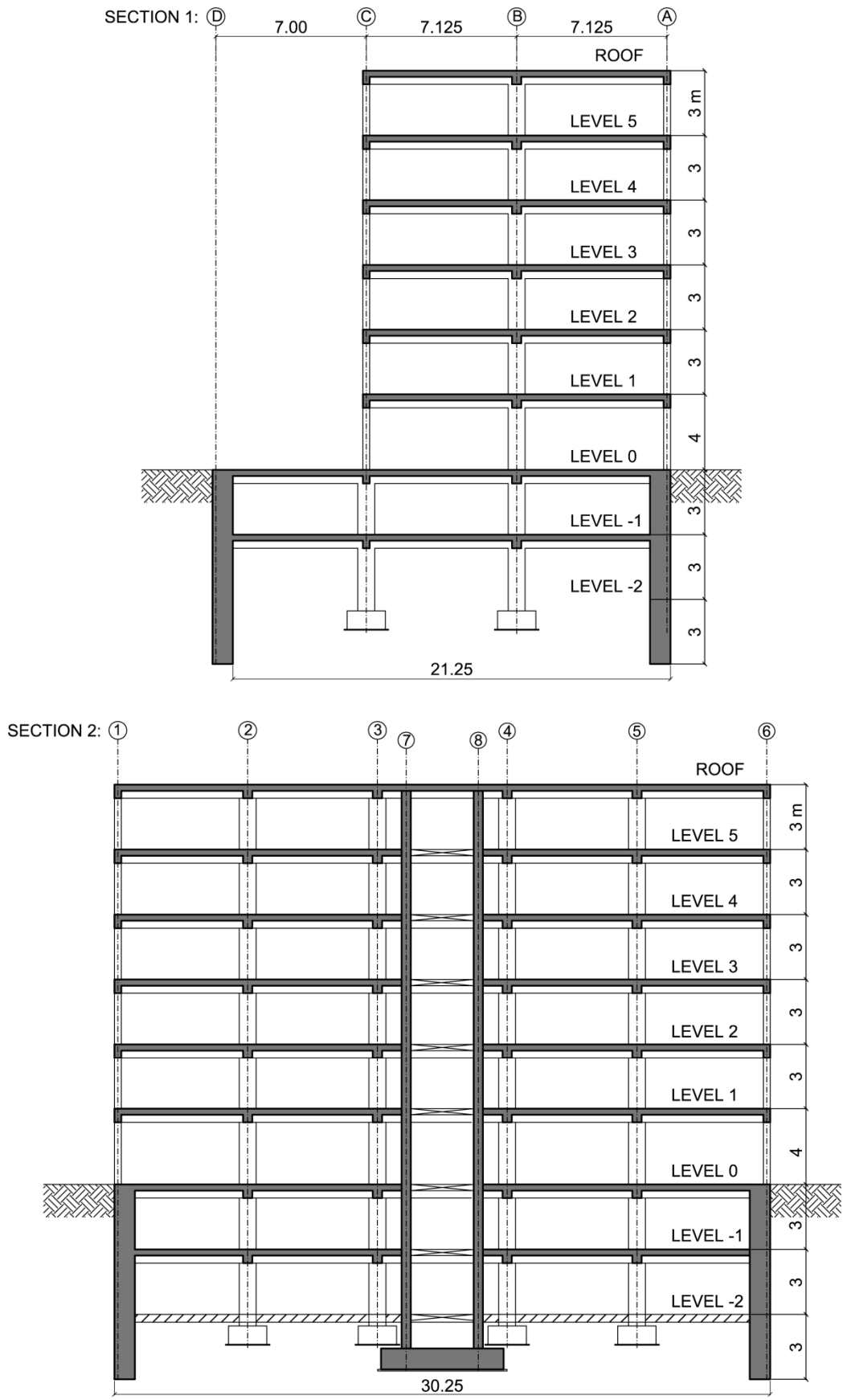

Fig. 3.1.2 Section S1 and S2 of the building

3.1.2. Materials

In Table 3.1.1 the assumed materials data and ULS safety factors are shown.

Table 3.1.1 Materials data

Concrete class	Steel class
<ul style="list-style-type: none"> ○ Beams and slabs: C25/30 ○ Columns: C30/37 Environmental class XC2-XC3 $c_{nom} = 30 \text{ mm}$ $\gamma_c = 1,5$	<ul style="list-style-type: none"> ○ Grade 500 class B $\gamma_s = 1,15$

3.2 Ultimate limit state design

3.2.1. Slab on beams

Figure 3.2.1 shows the considered beam (axis 2).

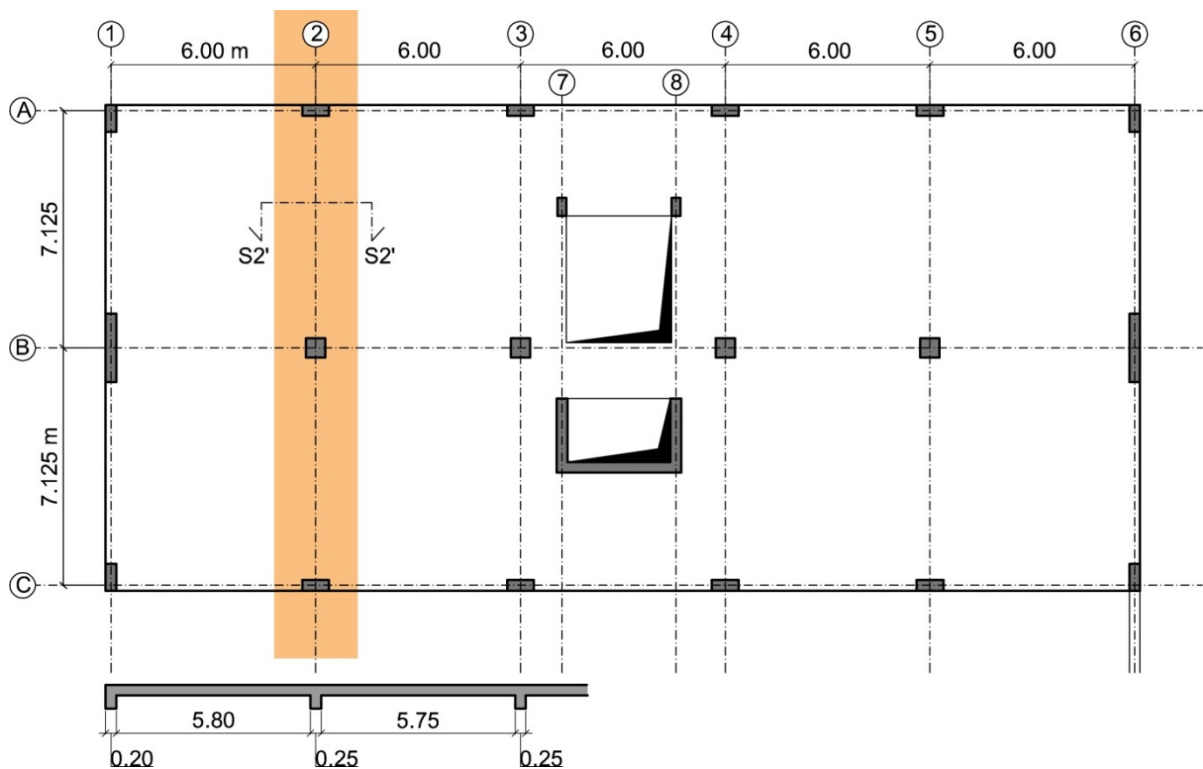

Fig. 3.2.1 Plan view of the slab on beams in axis 2

3.2.1.1 Static model and cross section of the slab on beams

The static model for the main bearing beam and the cross section S2' are in Figure 3.2.2: a continuous beam with a T-cross section where the effective width has to be defined.

According to *chapter 5.3.2.1 (EC 2)* the effective width b_{eff} is

$$b_{eff} = \sum b_{eff,i} + b_w \leq b, \quad (3.1)$$

where

$$b_{eff,i} = 0,2b_i + 0,1l_0 \leq 0,2l_0 \text{ and } b_{eff,i} \leq b_i. \quad (3.2)$$

Static system:

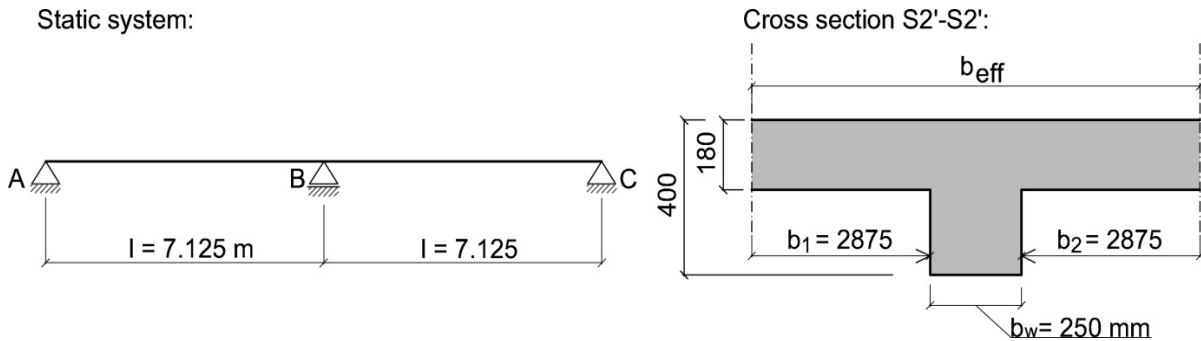

Fig. 3.2.2 Static system in axis 2 and cross section

Inserting zero points of bending moments (see Figure 3.2.3) into Eqn.(3.1) and (3.2) leads to:

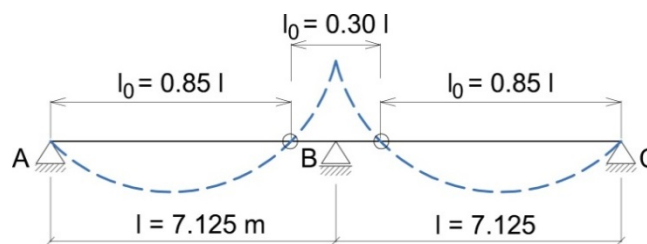

Fig. 3.2.3 Zero points of bending moments

Cross section of the T-beam at mid-span

$$b_{eff,1} = 0,2b_1 + 0,1(0,85l) = 0,2 \cdot 2875 + 0,1 \cdot (0,85 \cdot 7125) = 1181 \text{ mm} < b_1 = 2875 \text{ mm}$$

$$b_{eff,1} = b_{eff,2} = 1181 \text{ mm}$$

$$b_{eff} = 2 \cdot 1181 + 250 = 2611 \text{ mm}$$

Cross section of the T-beam at intermediate support

$$b_{eff,1} = 0,2 \cdot b_1 + 0,1 \cdot (0,30 \cdot l) = 0,2 \cdot 2875 + 0,1 \cdot (0,30 \cdot 7125) = 789 \text{ mm} < b_1 = 2875 \text{ mm}$$

$$b_{eff,1} = b_{eff,2} = 789 \text{ mm}$$

$$b_{eff} = 2 \cdot 788,8 + 250 = 1828 \text{ mm}$$

The internal forces for the beam axis 2 are presented in Figure 3.2.5. These maximum design moments M_{Ed} and shear forces V_{Ed} are the maximum values from different load cases in Chapter 2.

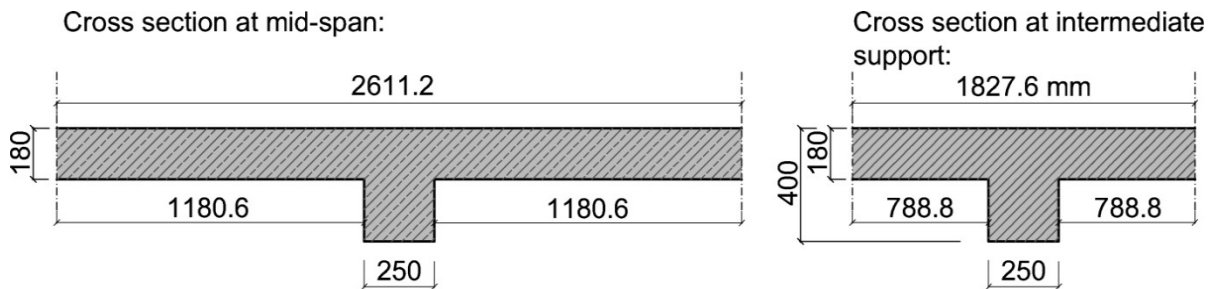

Fig. 3.2.4 Slab on beams with their effective width

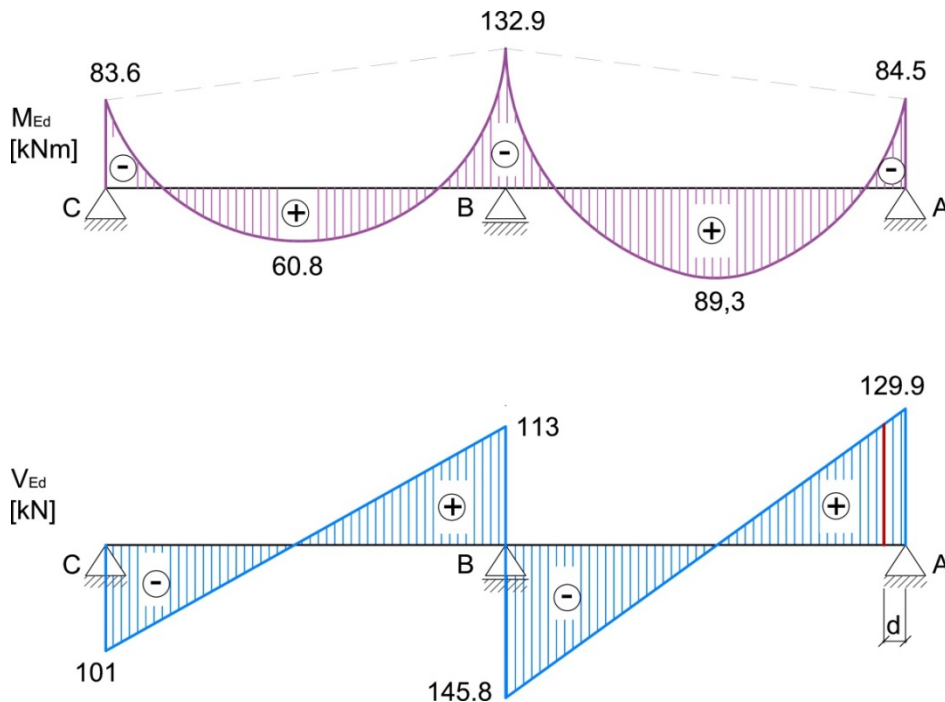

Fig. 3.2.5 Internal forces M_{Ed} and V_{Ed} of the axis 2 (combination of maximum values from various load cases)

3.2.1.2 Determination of the bending reinforcement in general

The determination of the bending reinforcement based on the method with the simplified concrete design stress block (*chapter 3.1.7 – EC 2*) is illustrated in Figure 3.2.6 assuming

$$\lambda = 0,8 \quad \eta = 1,0 \quad \text{as } f_{ck} \leq 50\text{MPa}$$

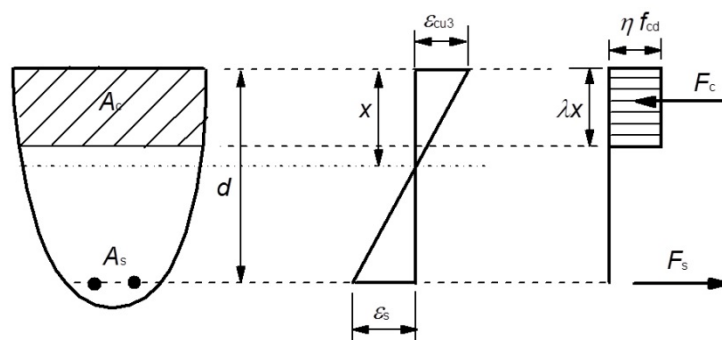

Fig. 3.2.6 Stress block according to EC 2

For the calculation of the bending reinforcement a design diagram can be derived (see Figure 3.2.7), which can generally be used for a rectangular compression zone.

Bending of the section (according to Figure 3.2.6) will induce a resultant tensile force F_s in the reinforcing steel, and a resultant compressive force in the concrete F_c which acts through the centroid of the effective compressed area .

For equilibrium, the ULS design moment M_{Ed} has to be balanced by the resisting moment M_{Rd} so that:

$$M_{Ed} = F_c z = F_s z \quad (3.3)$$

where z is the lever arm between the resultant forces F_c and F_s .

In Eqn. (3.3) the following expressions apply:

$$F_c = f_{cd} b x \quad (3.4)$$

$$z = d - \frac{x}{2} \quad (3.5)$$

Substituting Eqn. (3.4) and Eqn. (3.5) in Eqn. (3.3):

$$M_{Ed} = f_{cd} b d^2 \left(1 - \frac{z}{d}\right) \frac{z}{d} \cdot 2 \quad (3.6)$$

or

$$\frac{M_{Ed}}{b d^2 f_{cd}} = \left(1 - \frac{z}{d}\right) \frac{z}{d} \cdot 2 \quad (3.7)$$

This can be written as

$$\frac{M_{Ed}}{b d^2 f_{cd}} = K \quad (3.8)$$

where

$$K = \left(1 - \frac{z}{d}\right) \frac{z}{d} \cdot 2 \quad (3.9)$$

From equation 3.9 it follows that

$$\frac{z}{d} = 0,5 + \sqrt{0,25 - 0,5K}, \quad (3.10)$$

or written in another way:

$$\frac{z}{d} = 0,5(1 + \sqrt{1 - 2K}). \quad (3.11)$$

These equations are valid under the assumption that the reinforcing steel yields before the concrete crushes.

In order to define the limit of validity the “balanced” section is considered. It is mostly assumed that the balanced situation is reached for a depth of the compressed area equal to $x = 0,45d$.

The corresponding compression force is

$$F_{c,bal} = f_{cd} b x = f_{cd} \cdot b \cdot 0,8 \cdot 0,45 \cdot d = 0,36 b d f_{cd} \quad (3.12)$$

whereas the inner lever arm is:

$$z_{bal} = d - \frac{0,8 \cdot 0,45 d}{2} = 0,82 d \quad (3.13)$$

Combining Eqn.(3.11) and (3.12) gives:

$$M_{bal} = 0,295 b d^2 f_{cd} \quad (3.14)$$

then

$$\frac{M_{bal}}{b d^2 f_{cd}} = 0,295 = K' \quad (3.15)$$

From Eqn. (3.10) for this value of K' :

$$\frac{z}{d} = 0,82 \quad (3.16)$$

Taking this as a limit the resulting design diagram is in Figure 3.2.7.

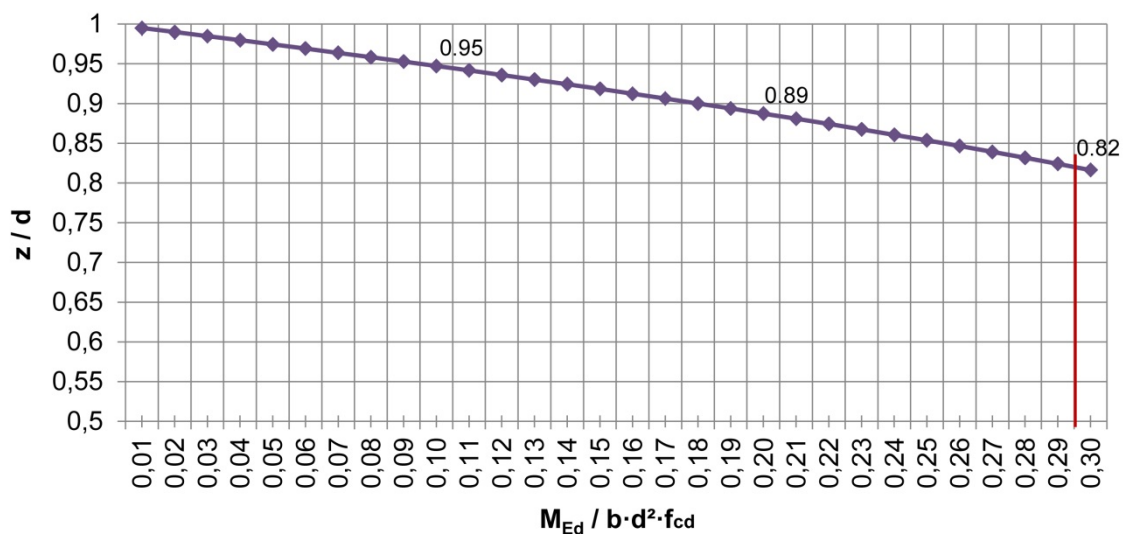

Fig. 3.2.7 Ratio z/d as a function of K up to limit value $K' = 0,295$

3.2.1.3 Determination of the bending reinforcement for the T-beams

Cross section at mid-span

The calculation for the bending reinforcement is done first for the cross section at mid-span (see Figure 3.2.8). The maximum ULS bending moment in span AB is $M_{Ed} = 89,3$ kNm. The effective depth d is 372 mm (see Chapter 2).

$$K = \frac{M_{Ed}}{bd^2f_{cd}} = \frac{89,3 \cdot 10^6}{2611,2 \cdot 372^2 \cdot \frac{25}{1,5}} = 0,0148 < 0,295 \Rightarrow$$

$$\Rightarrow \frac{z}{d} = 0,5(1 + \sqrt{1 - 2K}) = 0,5 \cdot (1 + \sqrt{1 - 2 \cdot 0,0148}) = 0,9925$$

$$A_{sl} = \frac{1}{f_{yd}} \left(\frac{M_{Ed}}{z} + N_{Ed} \right) \quad (3.17)$$

$$A_{sl} = \frac{1}{435} \cdot \left(\frac{89,3 \cdot 10^6}{372 \cdot 0,9925} \right) = 556 \text{ mm}^2$$

This means $4\phi 14 = 616 \text{ mm}^2$ or $5\phi 12 = 565 \text{ mm}^2$.

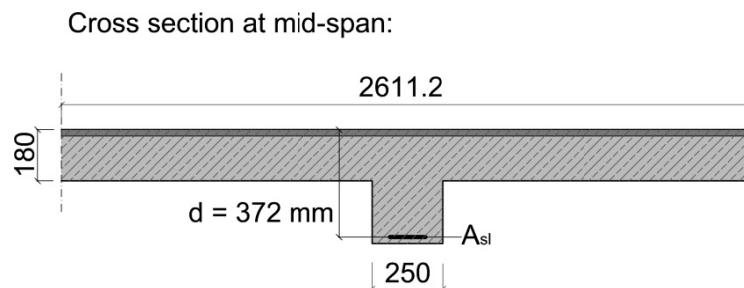

Fig. 3.2.8 T-beam cross-section at mid-span

Cross section at intermediate support

The cross section at intermediate support B is in Figure 3.2.9. The maximum ULS bending moment at the face of the support is $M_{Ed} = 132,9 \text{ kNm}$.

$$K = \frac{M_{Ed}}{bd^2f_{cd}} = \frac{132,9 \cdot 10^6}{250 \cdot 372^2 \cdot \frac{25}{1,5}} = 0,230 < 0,295 \Rightarrow$$

$$\frac{z}{d} = 0,5(1 + \sqrt{1 - 2K}) = 0,5 \cdot (1 + \sqrt{1 - 2 \cdot 0,230}) = 0,867$$

$$A_{sl} = \frac{1}{435} \cdot \left(\frac{132,9 \cdot 10^6}{372 \cdot 0,867} \right) = 947 \text{ mm}^2$$

So $7\phi 14 = 1078 \text{ mm}^2$ or $9\phi 12 = 1018 \text{ mm}^2$ can be spread over the effective width *EC2* suggests that part of the reinforcement is concentrated around the web zone

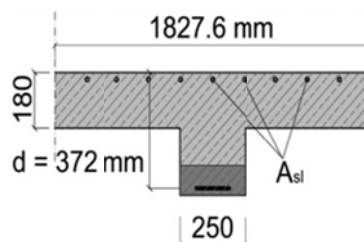

Fig. 3.2.9 Cross-section of T-beam - intermediate support B

3.2.1.4 Design of beams for shear

Control of shear capacity of the beams

The shear force may be determined at distance d from the support, where $V_{Ed,red}$ (see Figure 3.2.10) is :

$$\frac{129,9}{3,36} = \frac{V_{Ed,red}}{(3,36 - 0,372)} \Rightarrow V_{Ed,red} = 115,52 \text{ kN.}$$

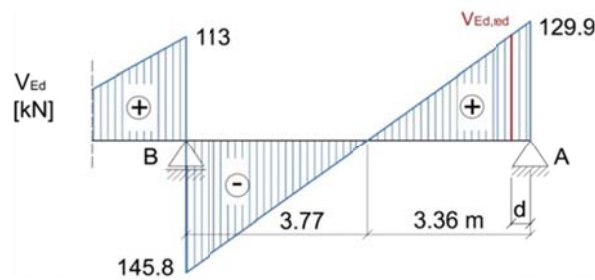

Fig. 3.2.10 Reduced shear force - support A

The first check according to *Chapter 6.2.2 (EC 2)* is the verification $V_{Ed} \leq V_{Rd,c}$ assuming a section without shear reinforcement. If this inequality does not hold, shear reinforcement is required.

$$V_{Rd,c} = [C_{Rd,c} k (100 \rho_l f_{ck})^{\frac{1}{3}}] b_w d \quad (3.12)$$

where

$$C_{Rd,c} = \frac{0,18}{\gamma_c} = \frac{0,18}{1,5} = 0,12$$

$$k = 1 + \sqrt{\frac{200}{d}} \leq 2,0 \quad k = 1 + \sqrt{\frac{200}{372}} = 1,73 < 2,0$$

$$\rho_l = \frac{A_{sl,prov}}{b_w d} \leq 0,02 \quad \rho_l = \frac{565}{250 \cdot 372} = 0,0061 = 0,61\%$$

$$V_{Rd,c} = [0,12 \cdot 1,73 \cdot (100 \cdot 0,0061 \cdot 25)^{\frac{1}{3}}] \cdot 250 \cdot 372 = 47902 \text{ N} = 47,90 \text{ kN}$$

$$V_{Rd,c} = 47,90 \text{ kN} < V_{Ed,red} = 115,52 \text{ kN} \Rightarrow$$

Shear reinforcement is required. Figure 3.2.11 shows the model for the shear capacity at stirrup yielding ($V_{Rd,s}$) and web crushing ($V_{Rd,max}$).

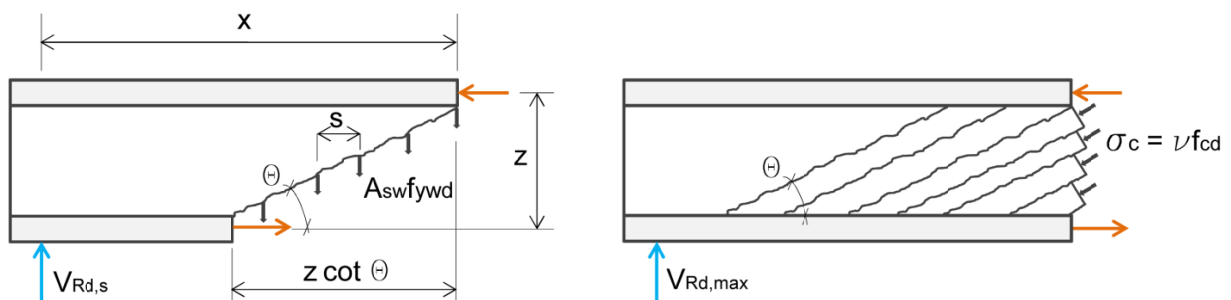

Fig. 3.2.11 Shear capacity at stirrup yielding and web crushing

The formulas for yielding shear reinforcement and web crushing are:

$$V_{Rd,s} = \frac{A_{sw}}{s} z f_{ywd} \cot \vartheta \quad (3.18)$$

$$V_{Rd,max} = b_w z v f_{cd} \frac{1}{\cot \vartheta + \tan \vartheta} \quad (3.19)$$

where

f_{ywd} is the design value for the stirrup steel yielding,

v is a reduction factor for the concrete compressive strength of the struts in the stress field, Figure 3.2.11 right,

ϑ is the compression strut angle, to be chosen between 45° and $21,8^\circ$ ($1 \leq \cot \vartheta \leq 2,5$).

As the geometry of the concrete section is given, the minimum shear reinforcement for the T-beam at support A is determined as follows:

$$V_{Rd,s} = V_{Ed} \Rightarrow \frac{A_{sw}}{s} = \frac{V_{Ed}}{z f_{ywd} \cot \vartheta}$$

$$a_{sw} = \frac{A_{sw}}{s} = \frac{115,52 \cdot 1000}{0,9 \cdot 0,372 \cdot 435 \cdot 2,5} = 317 \text{ mm}^2/\text{m}$$

Assuming double shear stirrups: $\phi 6/175 \text{ mm} = 339 > 317 \text{ mm}^2/\text{m}$

Minimum shear reinforcement (*Chapter 9.2.2.(5) – EC 2*):

$$a_{sw,min} = 0,08 \frac{\sqrt{f_{ck}}}{f_{yk}} b_w = 0,08 \cdot \frac{\sqrt{25}}{500} \cdot 0,25 = 0,002 \text{ m}^2 = 200 \text{ mm}^2$$

Maximum longitudinal distance of the stirrups (*chapter 9.3.2.(4) – EC 2*):

$$s_{l,max} = 0,75d(1 + \cot \alpha) \quad \text{for } \alpha = 90^\circ \quad s_{l,max} = 0,75 \cdot 372 = 279 > 175 \text{ mm}$$

The web crushing criterion checks the upper value of the shear capacity with:

$$v = 0,6 \left(1 - \frac{f_{ck}}{250}\right) = 0,6 \cdot \left(1 - \frac{25}{250}\right) = 0,54$$

It results that

$$V_{Rd,max} = 0,25 \cdot 0,9 \cdot 0,372 \cdot 0,54 \cdot \frac{25}{1,5} \cdot \frac{1}{2,5 + 0,4} = 0,25976 \text{ MN} = 259,8 \text{ kN} > V_{Ed,red} = 115,5 \text{ kN}$$

Figure 3.2.12 marks the stirrups layout at the area near support A.

Opposite to the design of bending reinforcement, where the “shift rule” requires a movement of the M_{Ed} -line in the unfavourable direction, for shear the opposite applies. As shown in Figure 3.2.11 the shear force at a distance x from the support, is carried by the stirrups over a distance $z \cot \vartheta$ at the left side of x . A practical approach is to move the V_{Ed} -line over a distance $z \cot \vartheta$ in the “favourable” direction (towards the support) and “cover” it with the resisting shear due to the reinforcement.

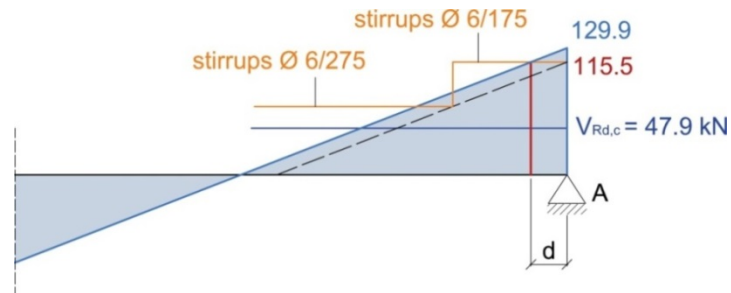

Fig. 3.2.12 Stirrup configuration - support A

Shear between web and flanges of the T-section

In the T-beam a check of interface shear should be done according to *Chapter 6.2.4 (EC 2)*, see Figure 3.2.13.

The strut angle Θ_f is defined by:

- $1,0 \leq \cot \Theta_f \leq 2,0$ for compression flanges ($45^\circ \geq \Theta_f \geq 26,5^\circ$)
- $1,0 \leq \cot \Theta_f \leq 1,25$ for tension flanges ($45^\circ \geq \Theta_f \geq 38,6^\circ$).

No transverse tension ties are required if the shear stress at the interface meets the condition:

$$v_{Ed} = \frac{\Delta F_d}{(h_f \Delta x)} \leq k f_{ctd} \quad (3.20)$$

where

ΔF_d is the increment of the longitudinal force in the flange and

f_{ctd} is the design value of the concrete tensile strength.

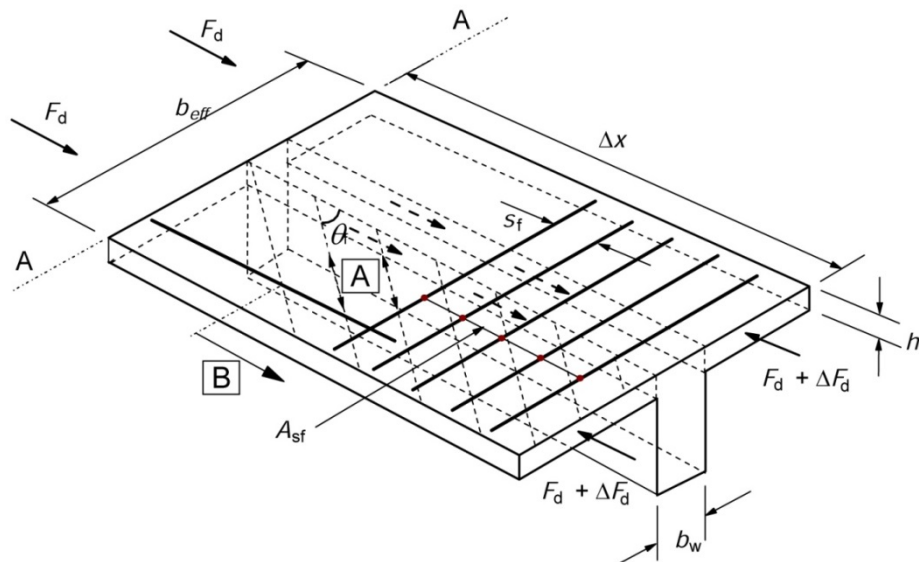

Fig. 3.2.13 Shear between web and flanges of T-sections according to EC 2

The recommended value is $k = 0,4$.

$$f_{ctd} = \frac{\alpha_{ct} f_{ctk,0.05}}{\gamma_c} \quad (3.21)$$

where

α_{ct} is a factor that considers sustained loading influences on the concrete tensile strength and unfavourable influences due to the type of loading. It is recommended to assume $\alpha_{ct} = 1,0$.

For C25/30:

$$f_{ctk,0.05} = 1,8 \text{ N/mm}^2 \quad \Rightarrow \quad f_{ctd} = \frac{1,0 \cdot 1,8}{1,5} = 1,2 \text{ N/mm}^2$$

If $v_{Ed} \leq 0,4f_{ctd}$ \Rightarrow no transverse reinforcement is required.

A check for interface shear at the T-beam in axis 2 (see Figure 3.2.1) for support A and C and at the intermediate support B is necessary. The cross-sections considered are in Figures 3.2.14 and 3.2.15.

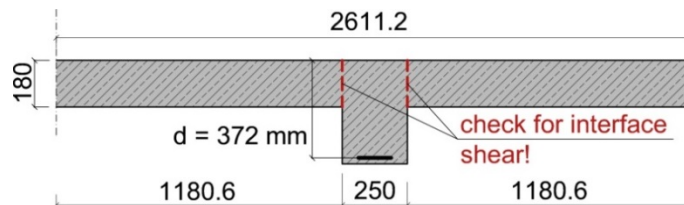

Fig. 3.2.14 T-beam for check of transverse shear reinforcement - supports A and C

$$v_{Ed,A} = \frac{1}{2} \frac{(b_{eff} - b_w) V_{Ed,red}}{b_{eff} z h_f} = \frac{1}{2} \cdot \frac{(2611,2 - 250)}{2611,2} \cdot \frac{115520}{0,9 \cdot 372 \cdot 180} = 0,87 \text{ N/mm}^2$$

$$v_{Ed,A} = 0,87 \text{ N/mm}^2 > 0,4 f_{ctd} = 0,4 \cdot 1,2 = 0,48 \text{ N/mm}^2 \quad \Rightarrow$$

Transverse shear reinforcement at support A is required!

Furthermore it has to be checked if transverse shear reinforcement at support C and the intermediate support are necessary. The reduced shear forces at distance d of the supports are determined and assembled in the following equations.

$$v_{Ed,C} = \frac{1}{2} \frac{(b_{eff} - b_w) V_{Ed,red,C}}{b_{eff} z h_f} = \frac{1}{2} \cdot \frac{(2611,2 - 250)}{2611,2} \cdot \frac{89830}{0,9 \cdot 372 \cdot 180} = 0,67 \text{ N/mm}^2$$

$$v_{Ed,C} = 0,67 \text{ N/mm}^2 > 0,4 f_{ctd} = 0,4 \cdot 1,2 = 0,48 \text{ N/mm}^2 \quad \Rightarrow$$

Transverse shear reinforcement at support C is required.

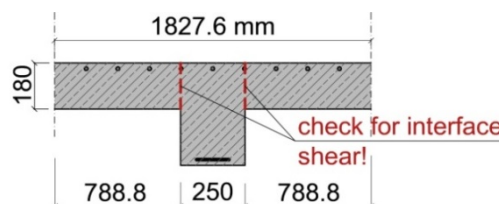

Fig. 3.2.15 T-beam for check of transverse shear reinforcement - support B

$$v_{Ed,B,left} = \frac{1}{2} \frac{(b_{eff} - b_w)}{b_{eff}} \frac{V_{Ed,red,B,left}}{zh_f} = \frac{1}{2} \cdot \frac{(1827,6 - 250)}{1827,6} \cdot \frac{101830}{0,9 \cdot 372 \cdot 180} = 0,73 \text{ N/mm}^2$$

$$v_{Ed,B,left} = 0,73 \text{ N/mm}^2 > 0,4f_{ctd} = 0,4 \cdot 1,2 = 0,48 \text{ N/mm}^2 \Rightarrow$$

Transverse shear reinforcement at support B_{left} is required.

$$v_{Ed,B,right} = \frac{1}{2} \frac{(b_{eff} - b_w)}{b_{eff}} \frac{V_{Ed,red,B,right}}{zh_f} = \frac{1}{2} \cdot \frac{(1827,6 - 250)}{1827,6} \cdot \frac{131410}{0,9 \cdot 372 \cdot 180} = 0,94 \text{ N/mm}^2$$

$$v_{Ed,B,right} = 0,94 \text{ N/mm}^2 > 0,4f_{ctd} = 0,4 \cdot 1,2 = 0,48 \text{ N/mm}^2 \Rightarrow$$

Transverse shear reinforcement at support B_{right} is required.

Figures 3.2.16 and 3.2.17 show the zones of beam axis 2 where transverse reinforcement is required.

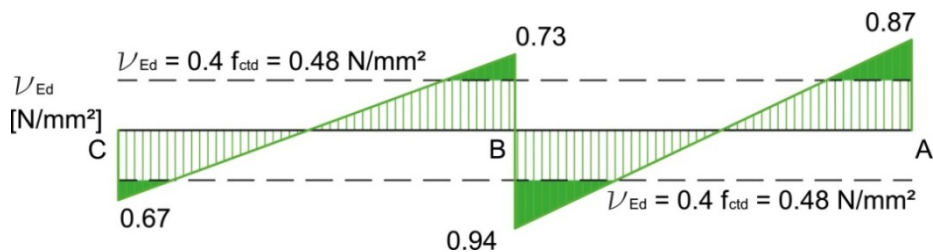

Fig. 3.2.16 Zones of beam axis 2 where transverse reinforcement is required

Transverse reinforcement

Near support A:

$$\frac{A_{st}}{s} = \frac{1}{2} \frac{(b_{eff} - b_w)}{b_{eff}} \frac{V_{Ed,red}}{zf_{yd}} \frac{1}{\cot \theta_f} \quad (3.22)$$

$$\frac{A_{st}}{s} = \frac{1}{2} \cdot \frac{(2611,2 - 250)}{2611,2} \cdot \frac{115520}{0,9 \cdot 372 \cdot 435} \cdot \frac{1}{2,0} = 0,18 \text{ mm}^2/\text{mm}$$

→ e.g. bars: $\phi 8/250 \text{ mm} = 0,20 \text{ mm}^2/\text{mm}$

Near support C:

$$\frac{A_{st}}{s} = \frac{1}{2} \cdot \frac{(2611,2 - 250)}{2611,2} \cdot \frac{89830}{0,9 \cdot 372 \cdot 435} \cdot \frac{1}{2,0} = 0,14 \text{ mm}^2/\text{mm}$$

→ e.g. bars: $\phi 8/250 \text{ mm} = 0,20 \text{ mm}^2/\text{mm}$

Near support B:

$$\frac{A_{st}}{s} = \frac{1}{2} \cdot \frac{(1827,6 - 250)}{1827,6} \cdot \frac{101830}{0,9 \cdot 372 \cdot 435} \cdot \frac{1}{2,0} = 0,15 \text{ mm}^2/\text{mm}$$

$$\frac{A_{st}}{s} = \frac{1}{2} \cdot \frac{(1827,6 - 250)}{1827,6} \cdot \frac{131410}{0,9 \cdot 372 \cdot 435} \cdot \frac{1}{2,0} = 0,19 \text{ mm}^2/\text{mm}$$

→ e.g. bars: $\phi 8/250 \text{ mm} = 0,20 \text{ mm}^2/\text{mm}$

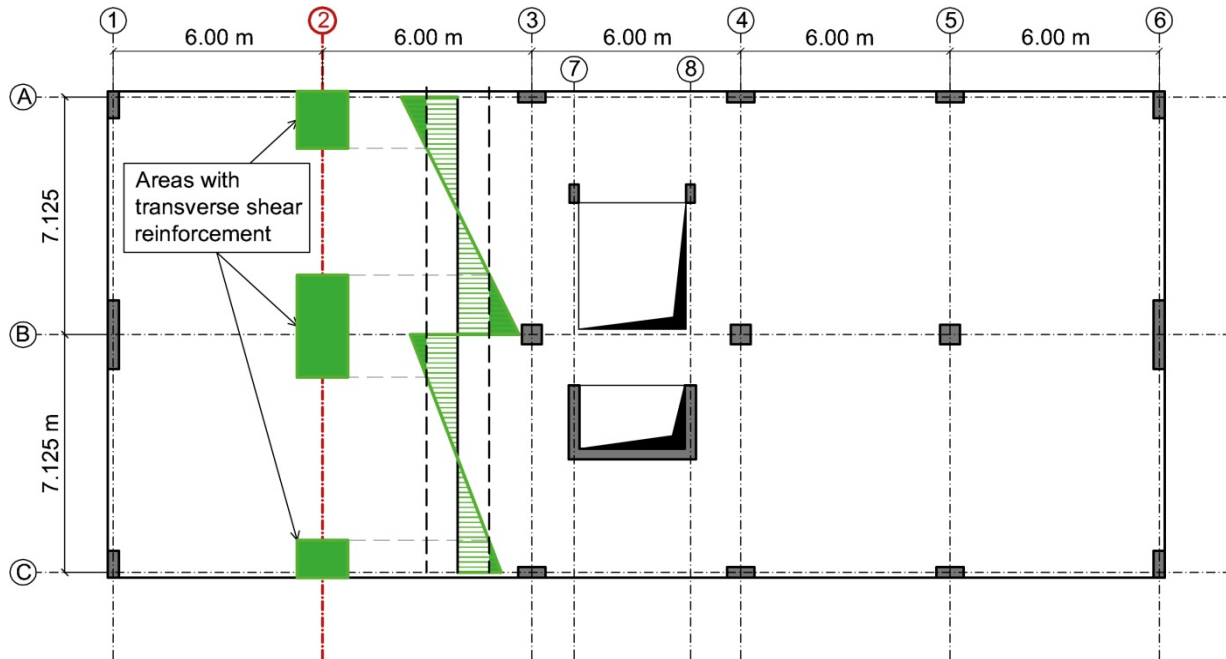

Fig. 3.2.17 Beam axis 2 – zones where transverse reinforcement is required

3.2.1.5 Design of slabs supported by beams

Figure 3.2.18 shows a design assumption for the load transmission from slabs to beams. Furthermore the static systems for a strip of the slab in both directions are depicted. The loads on the slab will be distributed into areas. It depends on the supporting conditions of the slab boundaries by which angle the loads are carried to the beams and bearing walls. The assumed angles are

- 45° for consistent edgings,
- 60° for disparate edgings (fixed connection) and
- 45° for disparate edgings (freely supported).

The dead load G_1 for the 180 mm thick slab amounts to 4,5 kN/m². The loads $G_2 = 3,0 \text{ kN/m}^2$ and $Q = 2,0 \text{ kN/m}^2$ were discussed in Chapter 1. Assuming the suggested safety factors for G and Q

$$G_{Ed} = 1,3 \cdot (4,5 + 3,0) = 9,75 \text{ kN/m}^2$$

$$Q_{Ed} = 1,5 \cdot 2,0 = 3,0 \text{ kN/m}^2$$

$$L_{Ed} = 9,75 + 3,0 = 12,75 \text{ kN/m}^2$$

Longitudinal reinforcement in slabs

The minimum reinforcement ratio follows from:

$$\rho_{l,\min} = 0,26 \frac{f_{ctm}}{f_{yk}} \quad (3.23)$$

For a C25/3 concrete and a B500 steel $\rho_{r,\min} = 0,26 \cdot \frac{2,6}{500} = 0,14\%$.

The effective depth d of the slab on beams has been determined (Chapter 1) as $d = 143$ mm.

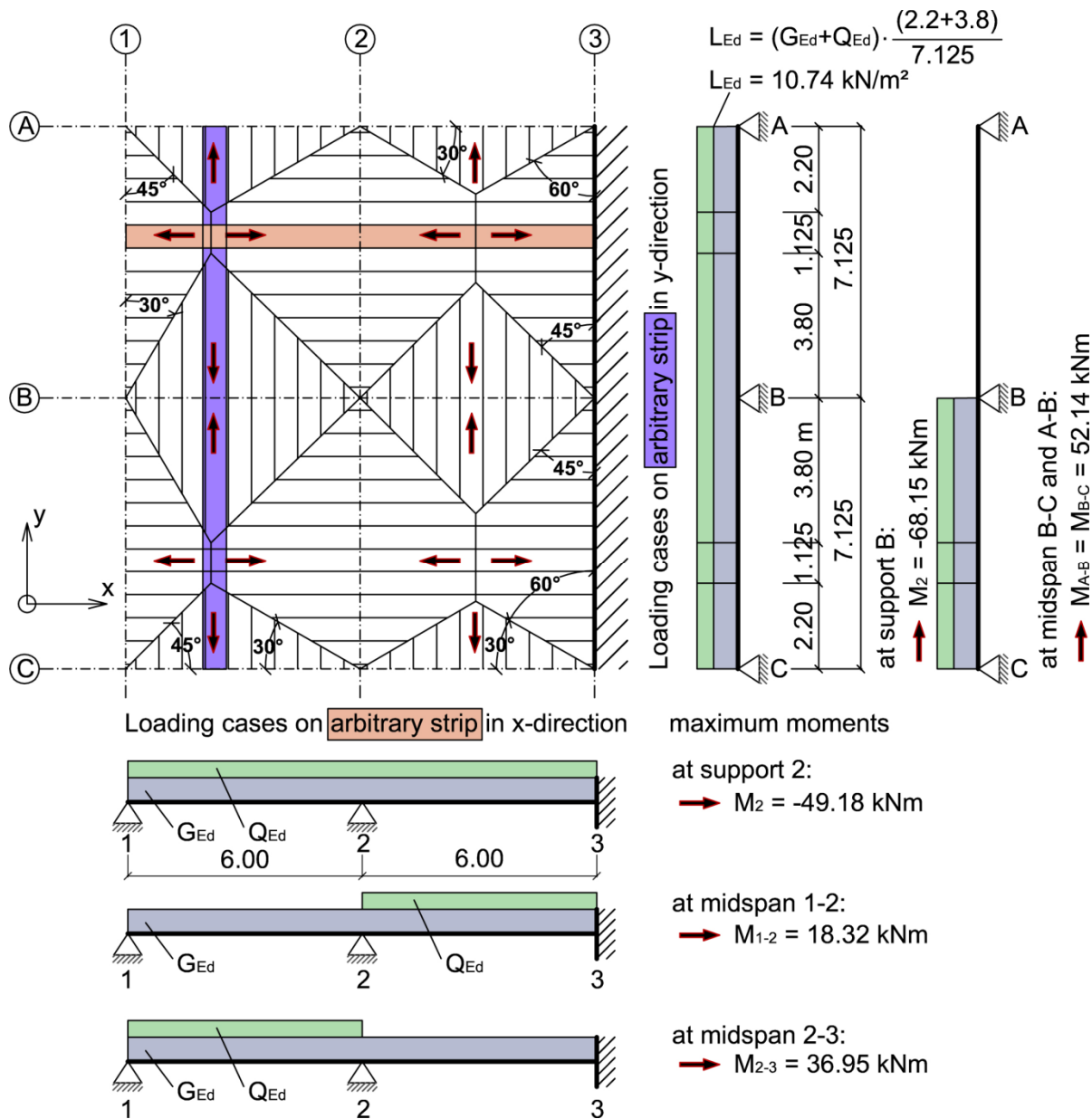

Fig. 3.2.18 Load transfer from slabs to beams and static systems

Longitudinal reinforcement in X-direction at intermediate support - axis 2:

$$K = \frac{M_{Ed}}{bd^2 f_{cd}} = \frac{49,18 \cdot 10^6}{10^3 \cdot 143^2 \cdot \frac{25}{1,5}} = 0,144 < 0,295 \Rightarrow$$

$$\Rightarrow \frac{z}{d} = 0,5(1 + \sqrt{1 - 2K}) = 0,5 \cdot (1 + \sqrt{1 - 2 \cdot 0,144}) = 0,922$$

$$A_{sl} = \frac{1}{435} \cdot \left(\frac{49,1 \cdot 10^6}{143 \cdot 0,922} \right) = 856 \text{ mm}^2$$

So the reinforcement ratio ρ can be determined (Eqn. 3.24).

$$\rho = \frac{A_s}{bd} \tag{3.24}$$

$$\rho = \frac{A_s}{bd} = \frac{856,36}{1000 \cdot 1,43} = 0,60\%$$

Longitudinal reinforcement in X-direction at mid span 1-2:

$$K = \frac{M_{Ed}}{bd^2 f_{cd}} = \frac{18,32 \cdot 10^6}{10^3 \cdot 143^2 \cdot \frac{25}{1,5}} = 0,0538 < 0,295 \Rightarrow$$

$$\Rightarrow \frac{z}{d} = 0,5(1 + \sqrt{1 - 2K}) = 0,5 \cdot (1 + \sqrt{1 - 2 \cdot 0,0538}) = 0,972$$

$$A_{sl} = \frac{1}{435} \cdot \left(\frac{18,32 \cdot 10^6}{143 \cdot 0,972} \right) = 303 \text{ mm}^2$$

$$\rho = \frac{A_s}{bd} = \frac{303}{1000 \cdot 1,43} = 0,21\%$$

Longitudinal reinforcement in X-direction at mid span 2-3 and at support in axis 3:

$$K = \frac{M_{Ed}}{bd^2 f_{cd}} = \frac{36,95 \cdot 10^6}{10^3 \cdot 143^2 \cdot \frac{25}{1,5}} = 0,108 < 0,295 \Rightarrow$$

$$\Rightarrow \frac{z}{d} = 0,5 \cdot (1 + \sqrt{1 - 2 \cdot K}) = 0,5 \cdot (1 + \sqrt{1 - 2 \cdot 0,108}) = 0,942$$

$$A_{sl} = \frac{1}{435} \cdot \left(\frac{36,95 \cdot 10^6}{143 \cdot 0,942} \right) = 630 \text{ mm}^2$$

$$\rho = \frac{A_s}{b \cdot d} = \frac{630}{1000 \cdot 1,43} = 0,44\%$$

Longitudinal reinforcement in Y-direction at intermediate support in axis B:

$$K = \frac{M_{Ed}}{bd^2 f_{cd}} = \frac{68,15 \cdot 10^6}{10^3 \cdot 143^2 \cdot \frac{25}{1,5}} = 0,200 < 0,295 \Rightarrow$$

$$\Rightarrow \frac{z}{d} = 0,5(1 + \sqrt{1 - 2K}) = 0,5 \cdot (1 + \sqrt{1 - 2 \cdot 0,200}) = 0,887$$

$$A_{sI} = \frac{1}{435} \cdot \left(\frac{68,15 \cdot 10^6}{143 \cdot 0,887} \right) = 1235 \text{ mm}^2$$

$$\rho = \frac{A_s}{bd} = \frac{1235}{1000 \cdot 1,43} = 0,86\%$$

Longitudinal reinforcement in Y-direction at mid span:

$$K = \frac{M_{Ed}}{bd^2 f_{cd}} = \frac{52,14 \cdot 10^6}{10^3 \cdot 143^2 \cdot \frac{25}{1,5}} = 0,153 < 0,295 \Rightarrow$$

$$\Rightarrow \frac{z}{d} = 0,5(1 + \sqrt{1 - 2K}) = 0,5 \cdot (1 + \sqrt{1 - 2 \cdot 0,153}) = 0,917$$

$$A_{sI} = \frac{1}{435} \cdot \left(\frac{52,14 \cdot 10^6}{143 \cdot 0,917} \right) = 915 \text{ mm}^2$$

$$\rho = \frac{A_s}{bd} = \frac{914}{1000 \cdot 1,43} = 0,64\%$$

In Figure 3.2.19 the theoretical reinforcement ratios of the slab are represented, all greater than the minimum.

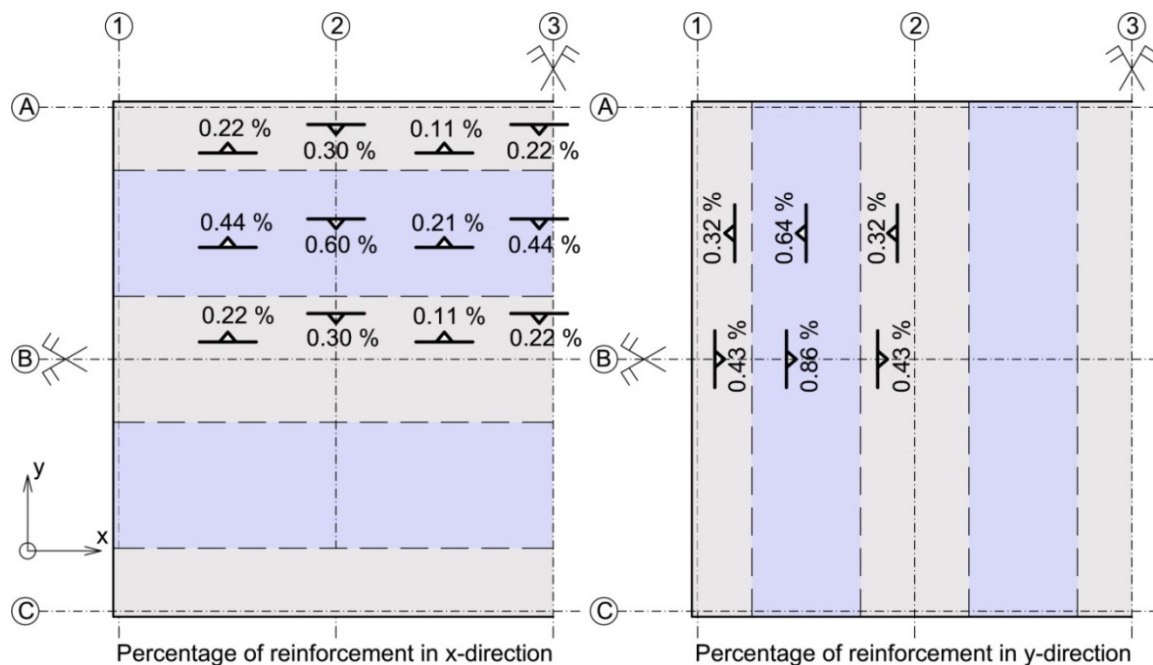

Fig. 3.2.19 Ground view of a symmetric part of the slab with reinforcement ratios

3.2.2. Flat slab

Figure 3.2.20 presents the flat slab with a height of 210 mm. It is favourable to choose an ideal small width for the strips passing over the supporting column, so that locally higher longitudinal reinforcement ratios apply.

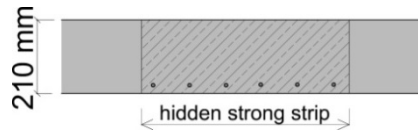

Fig. 3.2.20 Flat slab with hidden strong strips

3.2.2.1 Loads and internal forces for the calculation of the flat slab

$$G_{Ed} = 1,3 \cdot (5,25 + 3,0) = 10,73 \text{ kN/m}^2$$

$$Q_{Ed} = 1,5 \cdot 2,0 = 3,0 \text{ kN/m}^2$$

$$L_{Ed} = G_{Ed} + Q_{Ed} = 13,73 \text{ kN/m}^2$$

The moments for the flat slab may be obtained simply upgrading with the factor $13,73/12,75 = 1,077$ the moments calculated for the slab on beams in the previous analysis.

The moments in beam axis B and 2 are shown in Figure 3.2.21.

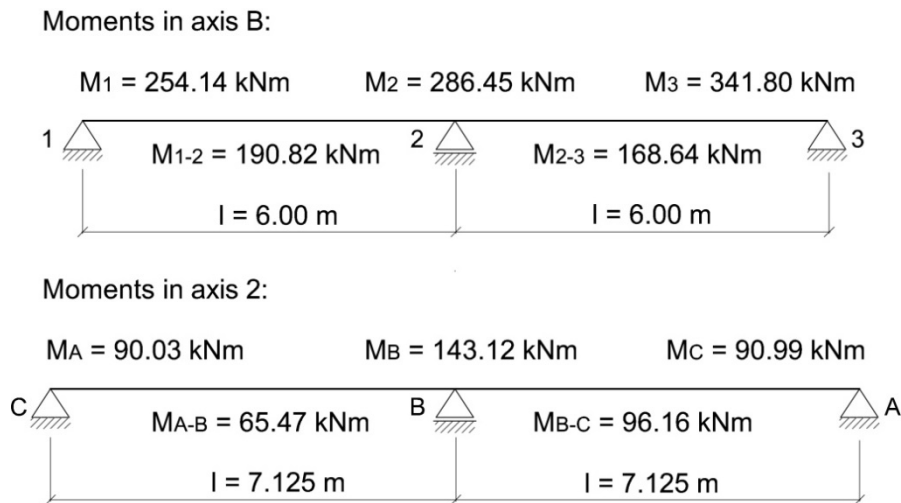

Fig. 3.2.21 Maximum moments for the calculation of the flat slab

3.2.2.2 Determination of the bending reinforcement

Longitudinal reinforcement in the flat slab

The effective depth d of the flat slab was assumed (chapter 1) as $d = 172 \text{ mm}$.

Longitudinal reinforcement in X-direction at intermediate support in axis 2:

$$K = \frac{M_{Ed}}{bd^2 f_{cd}} = \frac{286,45 \cdot 10^6}{3000 \cdot 172^2 \cdot \frac{25}{1,5}} = 0,194 < 0,295 \Rightarrow$$

$$\Rightarrow \frac{z}{d} = 0,5(1 + \sqrt{1 - 2K}) = 0,5 \cdot (1 + \sqrt{1 - 2 \cdot 0,194}) = 0,891$$

$$A_{sI} = \frac{1}{435} \cdot \left(\frac{286,45 \cdot 10^6}{172 \cdot 0,891} \right) = 4295 \text{ mm}^2$$

$$\rho = \frac{A_s}{bd} = \frac{4295}{3000 \cdot 1,72} = 0,83\%$$

Longitudinal reinforcement in X-direction at support in axis 3:

$$\frac{342}{286} = 1,19; \quad \rho = 1,19 \cdot 0,83\% = 0,99\%$$

Longitudinal reinforcement in X-direction at support in axis 1:

$$\frac{254}{286} = 0,89; \quad \rho = 0,89 \cdot 0,83\% = 0,74\%$$

Longitudinal reinforcement in X-direction at mid-span 1-2:

$$\frac{191}{286} = 0,67; \quad \rho = 0,67 \cdot 0,83\% = 0,56\%$$

Longitudinal reinforcement in X-direction at mid-span 2-3:

$$\frac{169}{286} = 0,59; \quad \rho = 0,59 \cdot 0,83\% = 0,49\%$$

Longitudinal reinforcement in Y-direction at intermediate support in axis B:

$$K = \frac{M_{Ed}}{bd^2 f_{cd}} = \frac{143,12 \cdot 10^6}{1500 \cdot 172^2 \cdot \frac{25}{1,5}} = 0,194 < 0,295 \Rightarrow$$

$$\Rightarrow \frac{z}{d} = 0,5 \cdot (1 + \sqrt{1 - 2 \cdot K}) = 0,5 \cdot (1 + \sqrt{1 - 2 \cdot 0,194}) = 0,891$$

$$A_{sI} = \frac{1}{435} \cdot \left(\frac{143,12 \cdot 10^6}{172 \cdot 0,891} \right) = 2147 \text{ mm}^2$$

$$\rho = \frac{A_s}{bd} = \frac{2147}{1500 \cdot 1,72} = 0,83\%$$

Longitudinal reinforcement in Y-direction at support in axis A and C:

$$\frac{91}{143} = 0,64; \quad \rho = 0,64 \cdot 0,83\% = 0,53\%$$

Longitudinal reinforcement in Y-direction at mid-span A-B:

$$\frac{96}{143} = 0,67; \quad \rho = 0,67 \cdot 0,83\% = 0,56\%$$

Longitudinal reinforcement in Y-direction at mid-span B-C:

$$\frac{65}{143} = 0,46; \quad \rho = 0,46 \cdot 0,83\% = 0,38\%$$

In Figure 3.2.22 the reinforcement ratios of the hidden beams in the flat slab are shown.

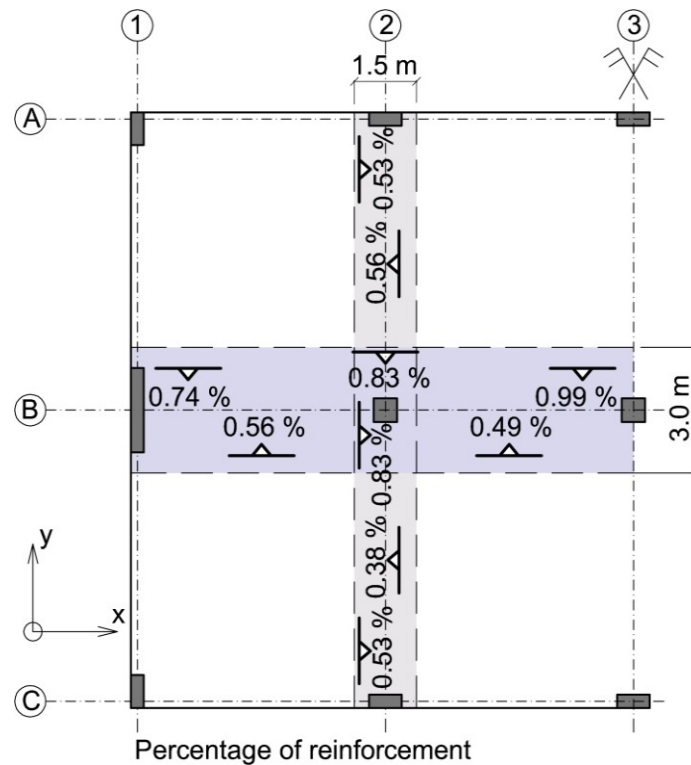

Fig.3.2.22 Symmetric part of the flat slab with reinforcement ratios of flat slab “hidden beams”

3.2.2.3 Punching shear - column B2

Figure 3.2.23 shows the punching shear phenomena in general.

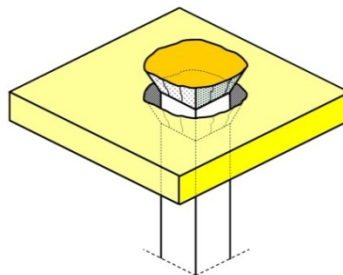

Fig. 3.2.23 Punching shear cylinder

At the junction column to slab the ULS vertical load from the slab to the column is calculated as $V_{Ed} = 705$ kN.

To take the eccentricity into account, a factor β can be determined with simplified assumptions according to *Chapter 6.4.3 (EC 2)*. The simplified case may be used only for structures where lateral stability does not depend on frame action and where adjacent spans do not differ by more than 25 %. The approximate values for β can be taken from Figure 3.2.24. For the current example $\beta = 1,15$ (interior column) applies.

Upper limit value for design punching shear stress in design

At the perimeter of the loaded area the maximum punching shear stress has to satisfy the following criterion (*EC 2, chapter 6.4.5*):

$$v_{Ed} = \frac{\beta V_{Ed}}{u_0 d} \leq v_{Rd,max} = 0,4v_{fd} \quad (3.25)$$

where

u_0 is the perimeter of the loaded area.

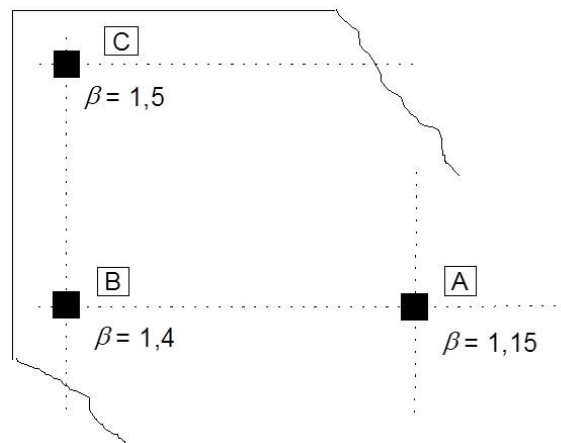

Fig. 3.2.24 Recommended values for β according to EC 2

First, a check of the upper limit value of punching shear capacity is required.

Further data

Dimensions of column B2: 500/500 mm

Effective depths for two-way reinforcement layers

$$d_y = 210 - 30 - \frac{16}{2} = 172 \text{ mm}$$

$$d_z = 210 - 30 - 16 - \frac{16}{2} = 156 \text{ mm}$$

Mean effective depth:

$$d = \frac{(172 + 156)}{2} = 164 \text{ mm}$$

$$v = 0,6 \left(1 - \frac{f_{ck}}{250}\right) = 0,6 \cdot \left(1 - \frac{25}{250}\right) = 0,54$$

Maximum allowable punching shear stress

$$v_{Rd,max} = 0,4 v f_{cd} = 0,4 \cdot 0,54 \cdot \frac{25}{1,5} = 3,6 \text{ N/mm}^2$$

$$v_{Ed} = \frac{\beta V_{Ed}}{u_0 d} = \frac{1,15 \cdot 705000}{4 \cdot 500 \cdot 164} = 2,47 \text{ N/mm}^2 < v_{Rd,max} = 3,6 \text{ N/mm}^2$$

The second verification is at perimeter u_1 where $v_{Ed} = \frac{\beta V_{Ed}}{u_1 d}$ (3.26)

The basic control perimeter u_1 is taken at a distance $2,0d$ from the loaded area and should be constructed as to minimise its length (see Figure 3.2.25). The definition of control perimeters of different cross sections is in Figure 3.2.26 (Chapter 6.4.2 – EC 2).

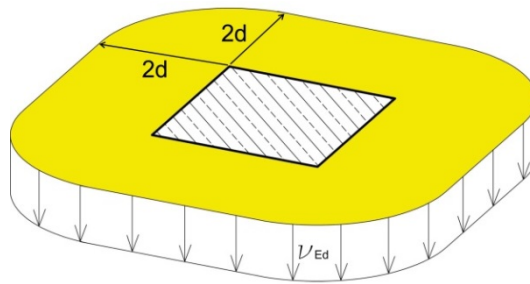

Fig. 3.2.25 Punching shear stress at perimeter

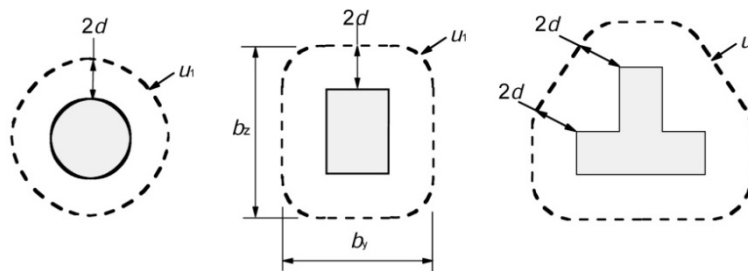

Fig. 3.2.26 Definition of control perimeters according to EC 2

The length of the control perimeter of the column with 500/500 mm sides is:

$$u_1 = 4 \cdot 500 + 2 \cdot \pi \cdot 2 \cdot 164 = 4061 \text{ mm}$$

$$v_{Ed} = \frac{1,15 \cdot 705000}{4061 \cdot 164} = 1,22 \text{ N/mm}^2$$

There is no punching shear reinforcement required if:

$$v_{Ed} \leq v_{Rd,c}$$

$$v_{Rd,c} = C_{Rd,c} k (100 \rho_l f_{ck})^{\frac{1}{3}} \geq v_{\min} \quad (3.27)$$

where

$$C_{Rd,c} = \frac{0,18}{\gamma_c} = \frac{0,18}{1,5} = 0,12$$

$$k = 1 + \sqrt{\frac{200}{d}} \leq 2,0 \quad k = 1 + \sqrt{\frac{200}{164}} = 2,10 > 2,0 \quad \Rightarrow k = 2,0$$

$$\rho_l = \sqrt{\rho_x \rho_y} \leq 0,02 \quad \rho_l = \sqrt{0,83 \cdot 0,83} = 0,83\%$$

$$v_{Rd,c} = 0,12 \cdot 2,0 \cdot (100 \cdot 0,0083 \cdot 25)^{\frac{1}{3}} = 0,66 \text{ N/mm}^2$$

$$v_{Rd,c} \geq v_{\min} = 0,035 k^{\frac{3}{2}} f_{ck}^{\frac{1}{2}} = 0,035 \cdot 2,0^{\frac{3}{2}} \cdot 25^{\frac{1}{2}} = 0,49 \text{ N/mm}^2 \Rightarrow \text{ok!}$$

$$v_{Ed} = 1,22 \text{ N/mm}^2 > v_{Rd,c} = 0,66 \text{ N/mm}^2 \Rightarrow \text{Punching shear reinforcement is required.}$$

Capacity with punching shear reinforcement

$$v_{Rd,s} = 0,75 v_{Rd,c} + 1,5 \left(\frac{d}{s_r} \right) A_{sw} f_{ywd,ef} \left(\frac{1}{u_1 d} \right) \sin \alpha \quad (3.28)$$

Shear reinforcement within a distance of $1,5d$ from the column (see Figure 3.2.27) is computed as follows.

$$f_{ywd,ef} = 250 + 0,25d \leq f_{ywd}$$

$$f_{ywd,ef} = 250 + 0,25d = 250 + 0,25 \cdot 164 = 291 \text{ N/mm}^2$$

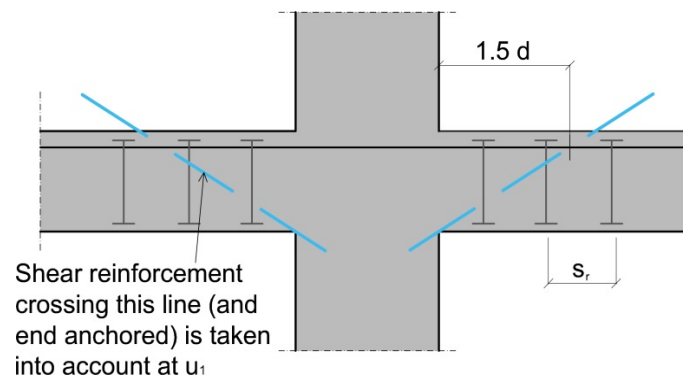

Fig. 3.2.27 Punching shear reinforcement

The steel contribution comes from the shear reinforcement inside a distance $1,5d$ from the edge of the loaded area, to ensure some anchorage at the upper end. The concrete contribution to resistance is assumed to be 75% of the design strength of a slab without shear reinforcement.

The distance s_r between the punching shear reinforcement perimeters should not be larger than $0,75d$ as shown in Figure 3.2.28.

$$s_r = 0,75d = 0,75 \cdot 164 = 123 \text{ mm}$$

$$v_{Rd,s} = v_{Ed} \Rightarrow A_{sw} = \frac{(v_{Ed} - 0,75v_{Rd,c})u_1 s_r}{1,5f_{ywd,ef}}$$

$$A_{sw} = \frac{(1,22 - 0,75 \cdot 0,66) \cdot 4060,88 \cdot 123}{1,5 \cdot 291} = 830 \text{ mm}^2$$

in each reinforcement perimeter.

The length of the outer perimeter, marked as section B in Figure 3.2.28, is:

$$u_{out} = \frac{\beta V_{Ed}}{v_{Rd,c} d} \tag{3.29}$$

$$u_{out} = \frac{1,15 \cdot 705000}{0,66 \cdot 164} = 7490 \text{ mm}$$

The distance from this perimeter to the edge of the column follows from:

$$a = \frac{(u_{out} - 4h)}{2\pi} = \frac{7490,30 - 4 \cdot 500}{2\pi} = 874 \text{ mm} = 5,33d$$

The outer punching shear reinforcement, marked as section A in Figure 3.2.28, has to be at a distance of no more than kd from the outer perimeter. The recommended factor k being $k=1,5$, the outer punching shear reinforcement is at a distance of: $5,33d - 1,5d = 3,83d$.

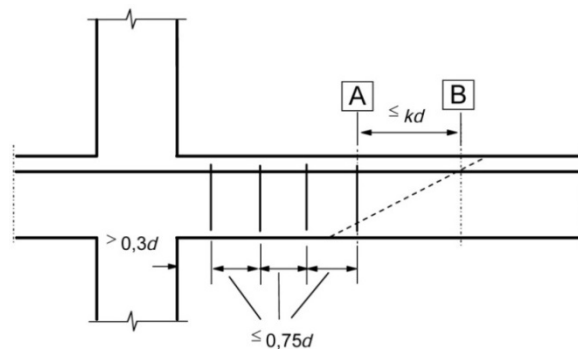

Fig. 3.2.28 Punching shear reinforcement perimeters according to EC 2

The distance between the punching shear reinforcement perimeters should not be larger than

$$0,75d = 0,75 \cdot 164 = 123 \text{ mm.}$$

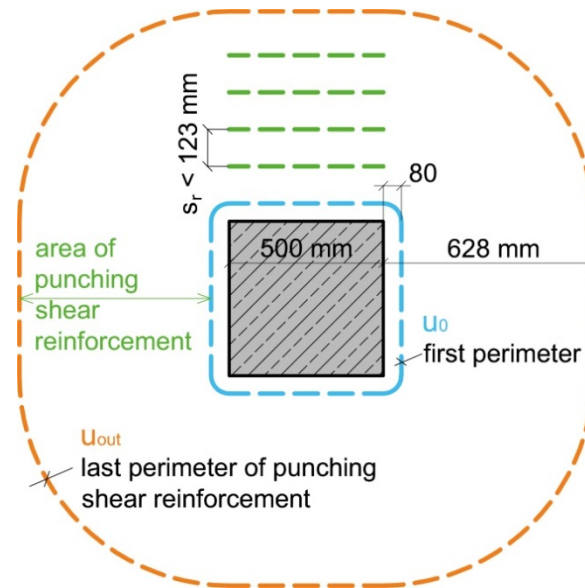

Fig. 3.2.29 Punching shear design of slab at column B2

3.2.2.4 Column B2

Second order effects under axial loading

General background according to chapter 5.8.2, 5.8.3.1, 5.8.3.2 and 5.8.3.3 (EC 2)

- Second order effects may be ignored if they are smaller than 10 % of the corresponding 1st order effects.
- “Slenderness” is defined as

$$\lambda = \frac{l_0}{i} = \frac{l_0}{\sqrt{\frac{I}{A}}} \quad (3.30)$$

where

- l_0 is the effective height of the column,
- i is the radius of gyration of the uncracked concrete section,
- I is the moment of inertia around the axis considered and
- A is the cross sectional area of the column.

For rectangular cross sections the λ value is

$$\lambda = 3,46 \frac{l_0}{h}$$

and for circular cross sections is

$$\lambda = 4 \frac{l_0}{h}$$

Figure 3.2.30 shows the basic cases for l_0 according to EC 2.

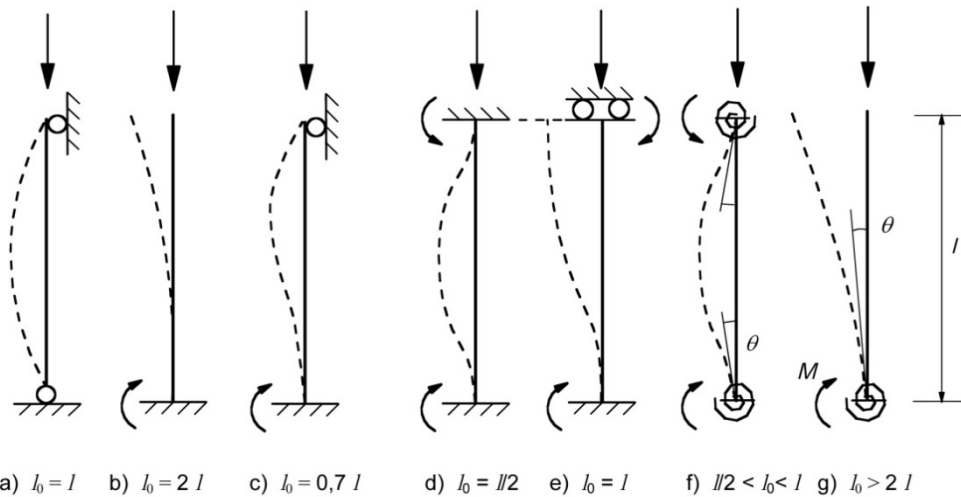

Fig. 3.2.30 Examples of different effective heights of columns according to EC 2

The relative flexibilities of rotation “springs” at the column ends (as in Figure 3.2.30, case f) and g)) may be calculated as

$$k = \frac{\theta EI}{M l} \quad (3.31)$$

where

θ is the rotation of restraining members for a bending moment M ,

EI is the bending stiffness of a compression member and

l is the height of the column between two rotation-springs.

The effective column height in a frame (see Figure 3.2.31) is different for braced and unbraced frames.

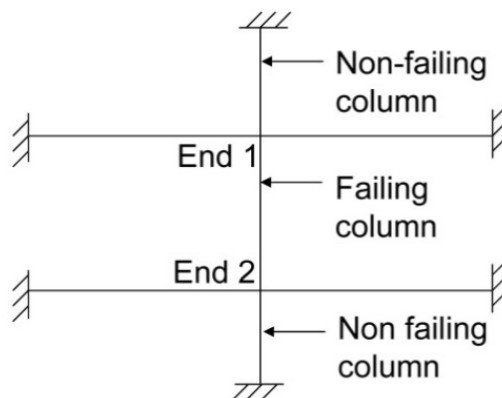

Fig.3.2.31 Determination of the effective column height

For braced frames:

$$l_0 = 0,5l \sqrt{\left(1 + \frac{k_1}{0,45 + k_1}\right) \left(1 + \frac{k_2}{0,45 + k_2}\right)} \quad (3.32)$$

For unbraced frames, the largest of:

$$l_0 = l \sqrt{1 + 10 \frac{k_1 \cdot k_2}{k_1 + k_2}} \quad \text{and} \quad l_0 = l \left(1 + \frac{k_1}{1 + k_1}\right) \left(1 + \frac{k_2}{1 + k_2}\right) \quad (3.33)$$

Values k_1 and k_2 are the relative spring stiffness at the ends of columns, l is the clear height of the column between the end restraints.

A simplifying assumption according to *Chapter 5.8 and 5.8.3.2 (EC 2)* is that the contribution of the adjacent “non failing” columns to the spring stiffness is ignored (if this contributes is positive to, i.e. increases the restraint). Furthermore for beams for (θ/M) the value $(l/2EI)$ may be assumed taking account of the loss of beam stiffness due to cracking.

Assuming the beams are symmetric with regard to the column and their dimensions are the same for the two stories, the following relations are found:

$$k_1 = k_2 = \frac{\left(\frac{EI}{l}\right)_{\text{column}}}{\left(\sum \frac{EI}{l}\right)_{\text{beams}}} = \frac{\left(\frac{EI}{l}\right)_{\text{column}}}{\left(\frac{2 \cdot 2 \cdot EI}{l}\right)_{\text{beams}}} = 0,25\chi$$

where

$$\chi = \frac{\left(\frac{EI}{l}\right)_{\text{column}}}{\left(\frac{EI}{l}\right)_{\text{beams}}}$$

The effective column length l_0 can for this situation is given in Table 3.2.1 as a function of χ .

- Second order effects may be ignored if the slenderness is smaller than the limit value λ_{lim} .
- In case of biaxial bending the slenderness should be calculated for an Y-direction. Second order effects need only to be considered in the direction(s) in which λ_{lim} is exceeded.

Table 3.2.1 Effective heights of columns according to EC 2

χ or	0 (fixed end)	0,25	0,50	1,00	2,00	∞ (pinned end)
$k_1 = k_2$	0	0,0625	0,125	0,25	0,50	1,00
l_0 for braced column	0,50 l	0,56 l	0,61 l	0,68 l	0,76 l	1,00 l
l_0 for unbraced column: (the larger of the values in the two rows)	1,00 l	1,14 l	1,27 l	1,50 l	1,87 l	∞
	1,00 l	1,12 l	1,13 l	1,44 l	1,78 l	∞

A column is qualified as “slender”, which implies that second order effects have to be taken into account, if $\lambda \geq \lambda_{lim}$. The limit value according to *chapter 5.8.3.1 (EC 2)* is :

$$\lambda_{lim} = \frac{20ABC}{\sqrt{n}} \quad (3.34)$$

where

$$A = \frac{1}{(1 + 0,2\varphi_{ef})},$$

$$B = \sqrt{1 + 2\omega},$$

$$C = 1,7 - r_m,$$

$$n = \frac{N_{Ed}}{A_c f_{cd}},$$

φ_{ef} is the effective creep factor. If it is unknown it can be assumed that $A = 0,7$,

$\omega = \frac{A_s f_{yd}}{A_c f_{cd}}$ is the mech. reinforcement ratio. If it is unknown $B = 1,1$ can be adopted.

$r_m = \frac{M_{01}}{M_{02}}$ is the ratio between end-moments in the column considered with $|M_{02}| \geq |M_{01}|$ (see Figure 3.2.32). In particular cases it can be supposed that r_m is 1,0. Then $C = 0,7$.

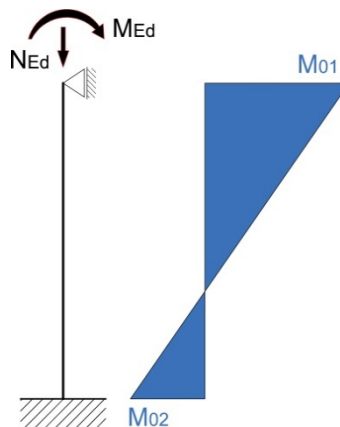

Fig. 3.2.32 Ratio between end-moments in column

Determination of the slenderness λ - column B2

For the current example (see Figure 3.2.33) the first step is the determination of the rotational spring stiffness at the end of the column.

The elasticity moduli E_{cm} are: for columns - concrete class C30/37 $E_{cm} = 33000 \text{ MN/m}^2$; for beams - concrete class C25/30 $E_{cm} = 31000 \text{ MN/m}^2$.

The moment of inertia for the 4 m high column B2 is:

$$I_{\text{column,B2}} = \frac{1}{12} \cdot 0,5^4 = 0,0052 \text{ m}^4$$

The spring stiffnesses are:

Column: $\frac{EI}{l} = \frac{33000 \cdot 0,0052}{4} = 43,0 \text{ MNm}$

Beam:
$$\frac{EI}{l} = \frac{31000 \cdot \frac{1}{12} \cdot 6 \cdot 0,21^3}{7,125} = 20,15 \text{ MNm}$$

$$k_1 = k_2 = \frac{\left(\frac{EI}{l}\right)_{\text{column}}}{\left(\frac{2 \cdot 2 \cdot EI}{l}\right)_{\text{beams}}} = \frac{43,0}{2 \cdot 2 \cdot 20,15} = 0,53$$

$$l_0 = 0,5l \sqrt{\left(1 + \frac{k_1}{0,45 + k_1}\right) \left(1 + \frac{k_2}{0,45 + k_2}\right)} = 0,5 \cdot 4 \cdot \sqrt{\left(1 + \frac{0,53}{0,98}\right)^2} = 3,1 \text{ m}$$

Actual slenderness of the column

$$\lambda = \frac{3,46l_0}{h} = \frac{3,46 \cdot 3,1}{0,5} = 22,5$$

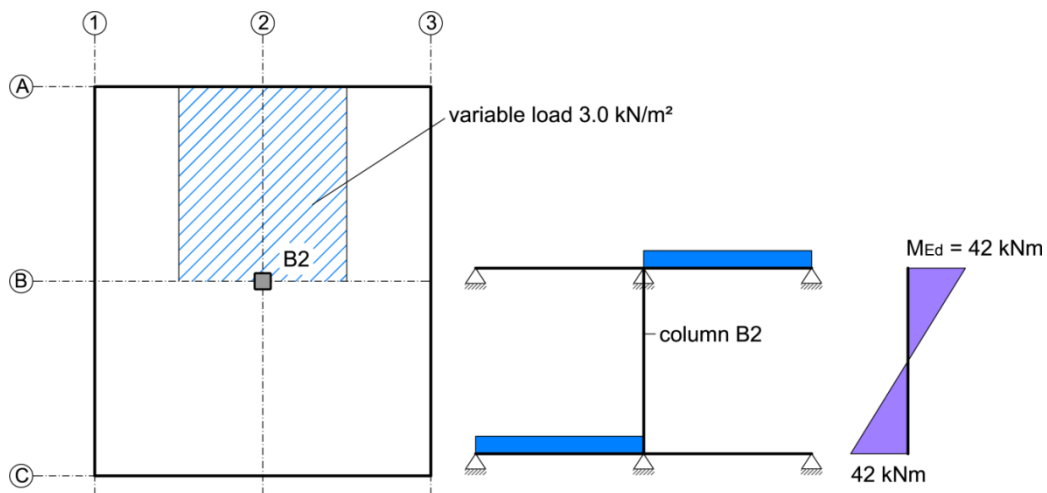

Fig. 3.2.33 Configuration of variable load on slab

Limit slenderness of the column

In Eqn. (3.35) the default values $A = 0,7$, $B = 1,1$ and $C = 0,7$ are used. The normal force N_{Ed} is (Chapter 2) $N_{Ed} = 4384 \text{ kN}$ and $M_{Ed} = 42 \text{ kNm}$.

$$n = \frac{N_{Ed}}{A_c f_{cd}} = \frac{4384000}{500^2 \cdot \frac{30}{1,5}} = 0,88$$

Therefore:

$$\lambda_{\text{lim}} = \frac{20 \cdot 0,7 \cdot 1,1 \cdot 0,7}{\sqrt{0,88}} = 11,5 \Rightarrow \lambda = 22,5 > \lambda_{\text{lim}} = 11,5$$

As the actual slenderness of the column is larger than the limit slenderness, second order effects have to be taken into account.

General: Method based on nominal curvature

$$M_{tot} = N_{Ed} (e_0 + e_i + e_2) \quad (3.35)$$

First order eccentricities (Figure 3.2.34) e_{01} and e_{02} are different. At the end of the column an equivalent eccentricity e_0 may be used, defined as:

$$e_0 = 0,6e_{02} + 0,4e_{01} \geq 0,4e_{02} . \quad (3.36)$$

If e_{01} and e_{02} have the same sign (Figure 3.2.34 left), the curvature is increased. Otherwise they would have different signs. Moreover it is assumed that $|e_{02}| \geq |e_{01}|$.

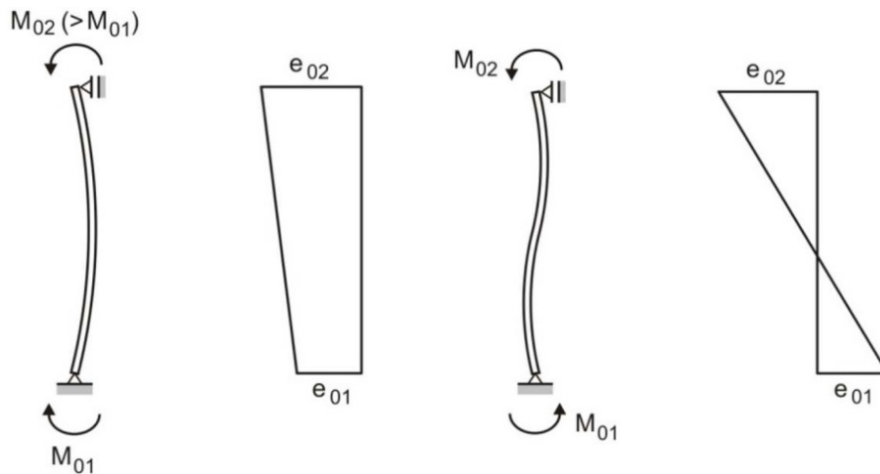

Fig. 3.2.34 Effects of the first order eccentricities e_{01} and e_{02}

The eccentricity e_i by imperfection follows from Chapter 5.2 (7) – EC 2.

$$e_i = \theta_i \frac{l_0}{2} \quad (3.37)$$

where

l_0 is the effective column height around the axis regarded,

$\theta_i = \theta_0 \alpha_h \alpha_m$ according to Chapter 5.2 (5) – EC 2,

$\theta_0 = \frac{1}{200}$ [rad] is the basic value,

$\alpha_h = \frac{2}{\sqrt{l}}; \frac{2}{3} \leq \alpha_h \leq 1$ is the reduction value for the height,

$\alpha_m = \sqrt{0,5(1 + \frac{1}{m})}$ is the reduction value for the number of building elements and

m is the number of the vertical elements which are required for the total impact.

The second order eccentricity e_2 follows from

$$e_2 = K_\phi K_r \frac{l_0^2}{\pi^2} \frac{\epsilon_{yd}}{0,45d} \quad (3.38)$$

where

$$K_{\varphi} = 1 + \left(0,35 + \frac{f_{ck}}{200} - \frac{\lambda}{150}\right) \varphi_{ef} \geq 1,0 \quad \text{and} \quad K_r = \frac{n_{ud} - n_{Ed}}{n_{ud} - n_{bal}} \leq 1,0.$$

and

$$\varphi_{ef} = \left(\frac{M_{0Eqp}}{M_{0Ed}}\right) \varphi_{\infty,t}$$

where

$\varphi_{\infty,t} = 2$ or 3 final creep ratio

$\frac{M_{0Eqp}}{M_{0Ed}}$ is the ratio between permanent load to design load.

Bending moment including second order effects

$$e_0 = \frac{M_{Ed}}{N_{Ed}} = \frac{42}{4384} = 0,010\text{m} = 10\text{mm}$$

At least the maximum of $\{l_0 / 20, b / 20$ or $20 \text{ mm}\}$ should be taken for e_0 . So the maximum e_0 value is:

$$e_0 = \frac{b}{20} = \frac{500}{20} = 25\text{mm}.$$

$$\theta_0 = \frac{1}{200}; \quad \alpha_h = \frac{2}{\sqrt{4}} = 1; \quad \alpha_m = \sqrt{0,5 \cdot \left(1 + \frac{1}{1}\right)} = 1 \quad \Rightarrow \quad \theta_0 = \frac{1}{200} \cdot 1 \cdot 1 = 0,005$$

$$e_i = 0,005 \cdot \frac{4000}{2} = 10\text{mm}$$

$$\varphi_{ef} = \frac{0,3 \cdot 2}{1,5 \cdot 2} \cdot 2 = 0,4$$

$$K_{\varphi} = 1 + \left(0,35 + \frac{30}{200} - \frac{22,1}{150}\right) \cdot 0,4 = 1,14$$

$$n_{ud} = 1 + \frac{\rho f_{yd}}{f_{cd}} = 1 + \frac{0,03 \cdot 435}{20} = 1,65$$

The reinforcing ratio estimated value is $\rho = 0,03$.

$$n_{Ed} = \frac{N_{Ed}}{A_c f_{cd}} = \frac{4384000}{500^2 \cdot 20} = 0,88$$

$n_{bal} = 0,4$ for concrete classes up to C50/60

$$K_r = \frac{1,65 - 0,88}{1,65 - 0,4} = 0,62$$

$$\varepsilon_{yd} = \frac{f_{yd}}{E_s} = \frac{\frac{500}{1,15}}{200000} = 2,17 \cdot 10^{-3}$$

$$e_2 = 1,14 \cdot 0,62 \cdot \frac{3200^2}{\pi^2} \cdot \frac{2,17 \cdot 10^{-3}}{0,25 \cdot 454} = 14 \text{ mm}$$

$$M_{tot} = 4384 \cdot (25 + 10 + 14) \cdot 10^{-3} = 214,82 \text{ kNm}$$

Column reinforcement

For the reinforcement of the column, the interaction diagram for a symmetric reinforced rectangular cross section is used. The diagram is valid for reinforcing steel with $f_{ck} = 500 \text{ N/mm}^2$.

$$\mu_{Ed} = \frac{M_{Ed}}{bh^2 f_{cd}} \quad (3.39)$$

$$v_{Ed} = \frac{N_{Ed}}{bh f_{cd}} \quad (3.40)$$

$$\mu_{Ed}; v_{Ed} \Rightarrow \omega_{tot} \Rightarrow A_{s,tot} = A_{s1} + A_{s2} = \omega_{tot} \frac{bh}{\frac{f_{yd}}{f_{cd}}} \quad (3.41)$$

$$\mu_{Ed} = \frac{214,82 \cdot 10^6}{500^3 \cdot \frac{30}{1,5}} = 0,086; \quad v_{Ed} = \frac{-4384 \cdot 10^3}{500^2 \cdot \frac{30}{1,5}} = -0,877$$

The "-" is conventionally used for the compression force N_{Ed} .

$$\frac{d_1}{h} = \frac{46}{500} = 0,092 \approx 0,10 \Rightarrow \omega_{tot} = 0,20$$

So the diagram (Figure 3.2.35) with the ratio $d_1/h = 0,10$ can be used.

$$A_{s,tot} = A_{s1} + A_{s2} = 0,20 \cdot \frac{500^2}{\frac{435}{20}} = 2299 \text{ mm}^2 \rightarrow \text{e.g. } 8\phi 20 = 2513 \text{ mm}^2$$

The maximum and minimum areas are:

$$A_{s,min} = \frac{0,10 N_{Ed}}{f_{yd}} = \frac{0,10 \cdot 4384000}{\frac{500}{1,15}} = 1008 \text{ mm}^2 \quad A_{s,max} = 0,04 A_c = 0,04 \cdot 500^2 = 10000 \text{ mm}^2$$

The calculation of the column reinforcement has been carried out for the most unfavourable direction. The bending moment in the other direction is only slightly smaller (Figure 3.2.32). Therefore, without further calculation, in the other direction $8\phi 20$ are also used, leading to the reinforcement configuration in Figure 3.2.36.

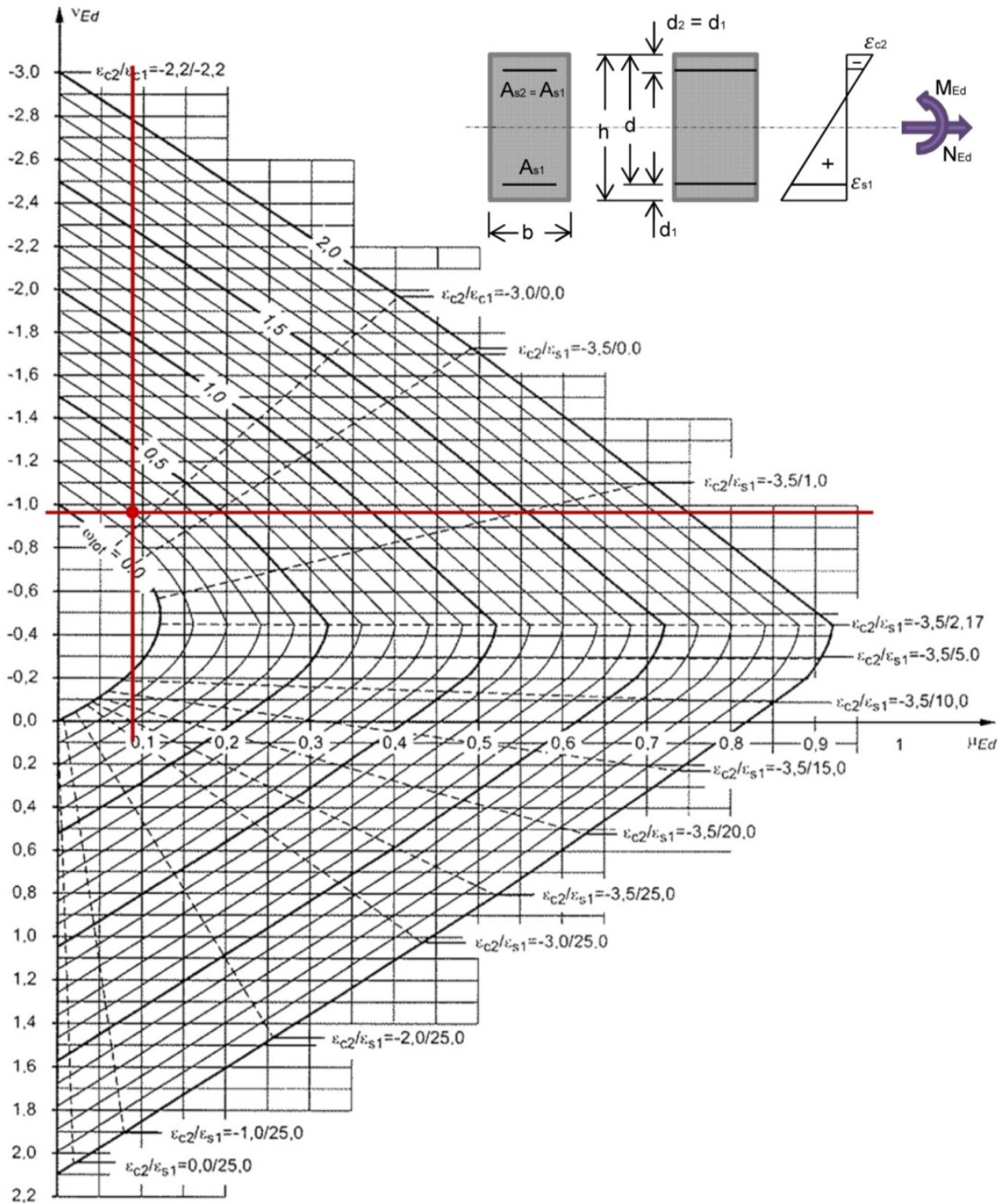

Fig. 3.2.35 Interaction diagram – double symmetric reinforced rectangular cross section (Zilch and Zehetmaier, 2010)

Figure 3.2.36 shows the cross section of the column with the reinforcement.

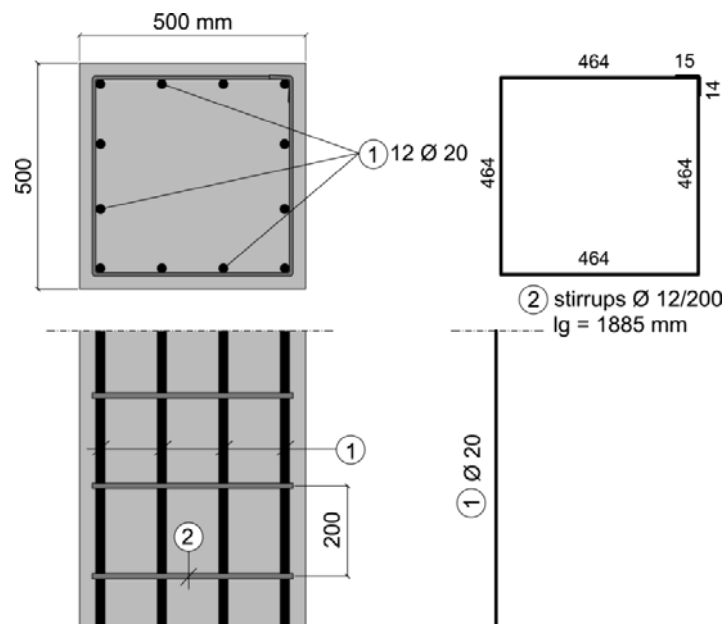

Fig. 3.2.36 Layout of the reinforced column B2

3.2.2.5 Design of shear walls

The stability of the building is ensured by two shear walls (one at each end of the building in axis B1 and B6) and a central core between the axis B7 and B8 (see Figure 3.2.1). The dimensions of the shear walls are in Figure 3.2.37.

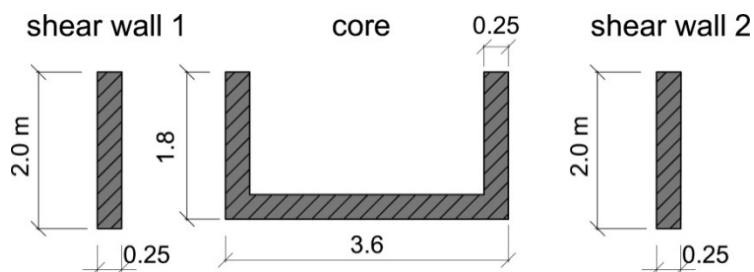

Fig. 3.2.37 Dimensions of the shear walls and the core

The moments of inertia around a centroid axis parallel to the X-global axis are:

$$I_x = (0,25 \cdot 2,0^3) / 12 = 0,167 \text{ m}^4 \quad \text{for shear walls 1 and 2}$$

$$I = 0,497 \text{ m}^4 \quad \text{for the central core}$$

The contribution of shear wall 1 to the total is:

$$\frac{0,167}{(2 \cdot 0,167 + 0,497)} = 0,20 \quad (20\%)$$

Second order effects

If second order effects are smaller than 10% of the first order moments, they can be neglected. (*Chapter 5.8.2(6) EC2*). Alternatively, according to *Chapter 5.8.3.3*, for bracing systems without significant shear deformations second order effects may be ignored if:

$$F_{V,Ed} \leq k_1 \frac{n_s}{n_s + 1,6} \frac{\sum E_{cd} I_c}{L^2} \quad (3.42)$$

where

- $F_{V,Ed}$ is the total vertical load (both on braced and unbraced elements),
- n_s is the number of storeys,
- L is the total height of the building above its fixed foundation,
- E_{cd} is the design E-modulus of the concrete, $E_{cd} = E_{cm} / \lambda_{cE}$, $\lambda_{cE} = 1,2$ and
- I_c is the moment of inertia of stabilizing elements.

The suggested value of the factor k_1 is $k_1 = 0,31$ if the section is cracked, the double if uncracked. For the shear wall the following actions are applied (see *Chapter 2*): the maximum moment $M_y = 66,59$ kNm with the corresponding normal force $N = -2392,6$ kN.

$$\sigma_N = \frac{N}{A} = \frac{-2,392}{(2 \cdot 0,25)} = 4,78 \text{ MN/m}^2$$

$$\sigma_M = \frac{M}{W} = \frac{-0,06659}{0,1667} = 0,40 < 4,78 \text{ MN/m}^2$$

where $W = bh^2/6 = (0,25 \cdot 2,0^2)/6 = 0,1667 \text{ m}^3$. The shear wall remains indeed uncracked therefore factor k_1 may be taken $k_1 = 2 \cdot 0,31 = 0,62$ according to *clause 5.8.3.3 (2) – EC 2*.

Whole building global second order effects

Assuming a six-storey building the shear walls' total inertia is $I_c = (2 \cdot 0,167 + 0,497) = 0,83 \text{ m}^4$. Applying *clause 5.8.3.3 – EC 2*

$$F_{V,Ed} \leq 0,62 \cdot \frac{6}{6 + 1,6} \cdot \frac{33 \cdot 10^6}{1,2} \cdot \frac{0,83}{19^2} = 30961 \text{ kN}$$

Assuming that 30% of the variable load is permanent, the unit load per story is $q_{Ed} = 9,75 + 0,3 \cdot 2 \cdot 1,5 = 10,65 \text{ kN/m}^2$. The total area for the load per story is $30 \cdot 14,25 = 427,5 \text{ m}^2$ so the total load per story can be estimated as $10,65 \cdot 427,5 = 4553 \text{ kN}$. For a six-storey building $F_{V,Ed}$ can be roughly calculated as:

$$F_{V,Ed} = 6553 \cdot 6 = 27318 \text{ kN} < 30961 \text{ kN}$$

The condition being fulfilled second order effects may be ignored.

For overall buckling in the X-direction the external shear walls contribution may be neglected and the central C core is considered. The C section of the central core has a moment of inertia around the Y-axis $I_y = (1,8 \cdot 3,6^3 - 1,55 \cdot 3,10^3)/12 = 3,15 \text{ m}^4$. Assuming the most severe value $k_1 = 0,31$ the result is $(0,31 \cdot 3,15) = 0,98 > (0,62 \cdot 0,83) = 0,51$: the condition is fulfilled in the X-direction also.

Verification by the moment magnification factor

Another possibility to check if second order effects should be considered is to determine the moment magnification factor (*clause 5.8.7.3 EC 2*). The simplified (5.30) formula can be written as:

$$M_{Ed} = \frac{M_{0Ed}}{1 - \frac{N_{Ed}}{N_B}} = f M_{0Ed} \quad (3.43)$$

where

$$f = \frac{1}{1 - \frac{N_{Ed}}{N_B}} \text{ is the moment magnification factor}$$

$$N_B = \frac{\pi^2 EI}{(1,12l)^2} \text{ is the Euler's buckling axial force}$$

N_{Ed} is the total axial force $F_{V,Ed} = 27318$ kN. In order $f \leq 1,1$ it results

$$\frac{N_{Ed}}{N_B} \leq 0,091 \quad (3.44)$$

Substituting in the relations above it results:

$$l \sqrt{\frac{F_{V,Ed}}{EI}} \leq 0,85 \quad \frac{19}{10^3} \cdot \sqrt{\frac{27318}{\frac{33}{1,2} \cdot 0,83}} = 0,66 < 0,85 \quad (3.45)$$

The assumption that the cross section is uncracked is correct because the condition in Eqn. (3.44) is fulfilled. Minimum reinforcement $A_{S,v,min}$ should be provided.

3.2.3. Slab with embedded elements

The top view of the slab with embedded lighting elements is represented in Figure 3.2.38. The bearing beams lie on axis A, B and C, the slab spans in transverse direction in between. A section of the lighting clay elements is in Figure 3.2.39. The clay elements are used as permanent formwork .

The upper concrete slab in the cross-section is 50 mm thick. Light reinforcement is applied in transverse direction at mid-depth. On top of the concrete slab mostly foamed or polystyrene concrete is applied, in which heating and electricity pipes and tubes are embedded, and at the bottom a clay finishing layer (see also Figure 3.2.39) is projected. Because of those protecting layers the concrete cover can be small (mostly governed by the bond criteria) and environmental classes X2-X3, elsewhere used as a general basis for the design, do not apply.

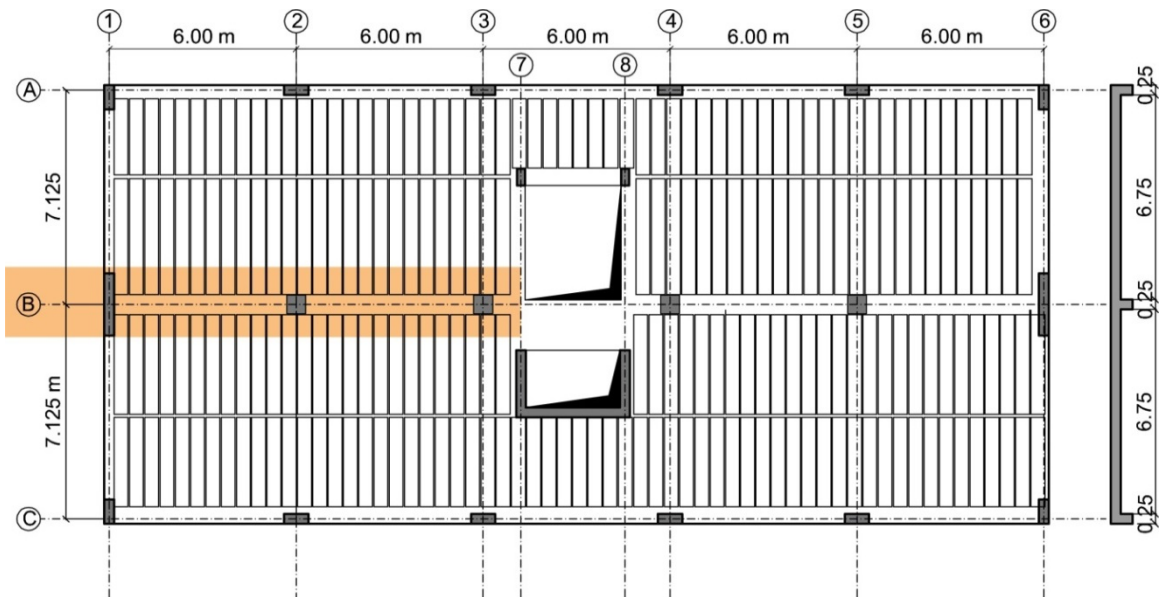

Fig. 3.2.38 Ground view of the slab with the embedded elements

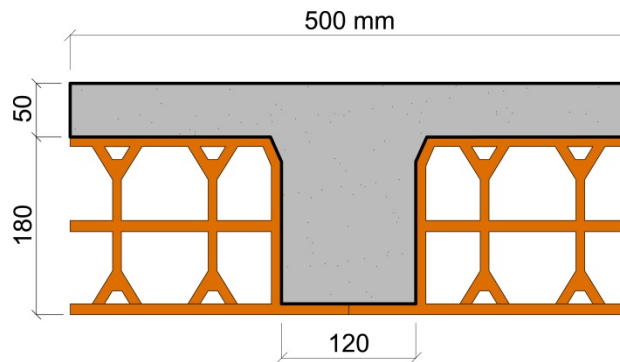

Fig. 3.2.39 Cross section of the slab with lighting elements

3.2.3.1 Bending reinforcement - beam axis B

Mid-span

The design bending moments at mid-span and at the internal support (intersection point of axes B and 2) are $M_{Ed} = 177,2$ kNm and $M_{Ed} = 266$ kNm respectively.

At mid-span the effective width b_{eff} is (clause 5.3.2.1 EC2):

$$b_{eff} = \sum b_{eff,i} + b_w \text{ where } b_{eff,i} = 0,2b_i + 0,1l_0$$

With $l_0 = 0,85l_1 = 0,85 \cdot 6000 = 5100$ mm, $b_w = 250$ mm and $b_i = 7125/2 = 3562$ mm it results $b_{eff} = 2695$ mm.

For the maximum bending moment at mid-span $M_{Ed} = 177,2$ kNm

$$\frac{M_{Ed}}{bd^2f_{cd}} = \frac{177,2 \cdot 10^6}{2695 \cdot 375^2 \cdot 16,7} = 0,0287$$

From the diagram in Figure 3.2.7 $z = 0,98d = 367$ mm. The area of the tensile reinforcement is

$$A_{sl} = \frac{M_{Ed}}{z f_{yd}} = \frac{177,2 \cdot 10^6}{0,98 \cdot 375 \cdot 435} = 1108 \text{ mm}^2$$

4 bars $\phi 20 = 1256 > 1108 \text{ mm}^2$ are adequate.

A mid-span cross-section showing the ribbed slab with embedded elements is in Figure 3.2.40.

Internal support

At the intermediate support B-2 the effective width is again calculated with

$$b_{eff} = \Sigma b_{eff,i} + b_w \text{ with } b_{eff,i} = 0,2b_i + 0,1l_0.$$

Here

$$l_0 = 0,15(l_1 + l_2) = 0,15(6000 + 6000) = 1800 \text{ mm}$$

so that

$$b_{eff} = 0,2 \cdot 3562 + 0,1 \cdot 1800 = 892 \text{ mm}.$$

This results in an effective width

$$b_{eff} = 2 \cdot 892 + 250 = 2035 \text{ mm}.$$

At first it is verified whether compressive reinforcement is required. The value K is

$$K = \frac{M_{Ed}}{bd^2 f_{cd}} = \frac{266 \cdot 10^6}{250 \cdot 375^2 \cdot 16,7} = 0,45 > 0,295$$

So compression reinforcement is indeed necessary. The parameter $(d-d')$ is the distance between the compression reinforcement and the tension reinforcement. The reinforcement A_{sc} follows from:

$$A_{sc} = \frac{(K - K_{bal}) f_{cd} b d^2}{f_{yd} (d - d')} \quad (3.46)$$

$$A_{sc} = \frac{(0,45 - 0,295) \cdot 16,7 \cdot 250 \cdot 375^2}{435 \cdot (375 - 30)} = 605 \text{ mm}^2$$

The tensile reinforcement is then:

$$A_{st} = \frac{K_{bal} f_{cd} b d^2}{f_{yd} z_{bal}} + A_{cs} \quad (3.47)$$

$$A_{st} = \frac{0,295 \cdot 16,7 \cdot 250 \cdot 375^2}{435 \cdot 0,82 \cdot 375} + 605 = 1899 \text{ mm}^2$$

This reinforcement can be spread over the effective width $b_{eff} = 2035 \text{ mm}$. So, 10 bars $\phi 16 = 10 \cdot 201 = 2010 \text{ mm}^2$ are adequate. The bars can be spread over the effective width.

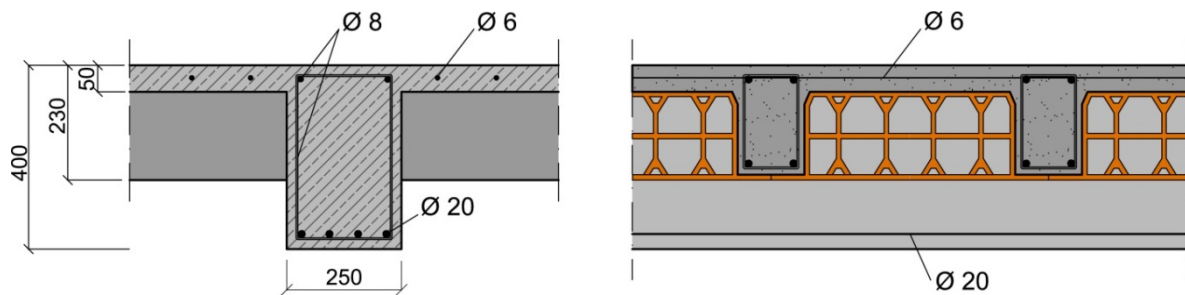

Fig. 3.2.40 Cross sections of bearing beam, axis B, at mid-span 2 (left) and of slab with embedded elements adjacent to bearing beam B (right)

3.2.3.2 Bending reinforcement of the slab with embedded elements

A cross section of the floor is in Figure 3.2.39. The uniformly distributed load on the slab consists of the dead load components $G_1 = 2,33 \text{ kN/m}^2$ and $G_2 = 3,0 \text{ kN/m}^2$. The variable load is $2,0 \text{ kN/m}^2$. The design load is:

$$Q_{Ed} = 1,3 \cdot (2,33 + 3,0) + 1,5 \cdot 2,0 = 9,93 \text{ kN/m}^2.$$

For a unit slab width the bending moments at the intermediate support (B) is $M_{Ed} = 63,0 \text{ kNm/m}$ and at mid-span $M_{Ed} = 39,2 \text{ kNm/m}$ (Figure 3.2.41).

Mid-span

$$K = \frac{M_{Ed}}{bd^2 f_{cd}} = \frac{39,2 \cdot 10^6}{1000 \cdot 197^2 \cdot 16,7} = 0,065 < 0,295$$

The inner lever arm is $0,97d = 0,97 \cdot 197 = 191 \text{ mm}$, the area of the bending tensile reinforcement is:

$$A_{sl} = \frac{M_{Ed}}{z f_{yd}} = \frac{39,2 \cdot 10^6}{191 \cdot 435} = 472 \text{ mm}^2 / \text{m}$$

Per rib this means $472/2 = 235 \text{ mm}^2$ or 2 bars $\phi 12 \text{ mm} = 226 \text{ mm}^2$. (A 4% lower value is acceptable since no moment redistribution was applied).

Loading cases for beams with embedded elements

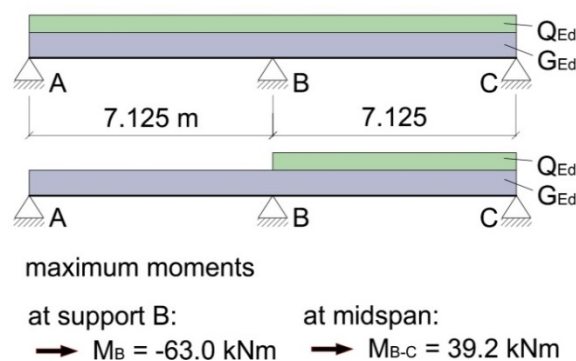

Fig.3.2.41 Design bending moment at internal support and mid-span - beam with embedded lighting elements uniformly distributed loaded

Internal support

As the support may be considered to provide limited restraint to rotation according to *clause 5.3.2.2(4) – EC2* the theoretical moment may be reduced to take into account the reaction distribution over the width of the support.

The design support reaction is $F_{Ed,sup} = 1,25 \times 9,93 \times 7,125 = 88,5$ kN/m

The moment reduction is $\Delta M_{Ed} = F_{Ed,sup} t / 8 = 88,5 \cdot 0,25 / 8 = 2,76$ kNm therefore the moment is $M_{Ed} = 63,0 - 2,76 = 60,2$ kNm/m.

First it is controlled whether compression reinforcement is necessary:

$$K = \frac{M_{Ed}}{bd^2 f_{cd}} = \frac{60,2 \cdot 10^6}{240 \cdot 190^2 \cdot 16,7} = 0,417 > 0,295$$

So compression reinforcement is required:

$$A_{sc} = \frac{(K - K_{bal}) f_{cd} b d^2}{f_{yd} (d - d')} = \frac{(0,417 - 0,295) \cdot 16,7 \cdot 240 \cdot 190^2}{435 \cdot (190 - 30)} = 253 \text{ mm}^2$$

Per rib this is $253/2 = 127$ mm² or 2 bars $\phi 10$ mm = 156 mm².

Tensile reinforcement is then

$$A_{st} = \frac{K_{bal} f_{cd} b d^2}{f_{yd} z_{bal}} + A_{sc} = \frac{0,295 \cdot 16,7 \cdot 240 \cdot 190^2}{435 \cdot 0,82 \cdot 190} + 253 = 882 \text{ mm}^2$$

Per rib this is $882/2 = 441$ mm² or 2 bars $\phi 18 = 508$ mm². The application of this reinforcement is limited to the width of the rib, as it cannot be placed in the thin upper slab (50 mm) because of the presence of the transverse reinforcement (see below).

Bending reinforcement of slab with embedded elements

In Figure 3.2.39 the net span of the top 50 mm slab between the ribs is 380 mm. The design load per square metre is

$$Q_{Ed} = 1,3 \cdot (1,2 + 3) + 1,5 \cdot 2 = 8,5 \text{ kN/m}^2.$$

The design bending moment at the fixed-end supports is

$$M_{Ed} = (1/12) l^2 Q_{Ed} = (1/12) \cdot 0,38^2 \cdot 8,5 = 0,10 \text{ kNm/m}$$

$$K = \frac{M_{Ed}}{bd^2 f_{cd}} = \frac{0,10 \cdot 10^6}{1000 \cdot 25^2 \cdot 16,7} = 0,01$$

So the inner lever arm is $z = 0,99d = 0,99 \cdot 25 = 24,7$ mm and the required longitudinal reinforcement is

$$A_{st} = \frac{M_{Ed}}{z f_{yd}} = \frac{0,1 \cdot 10^6}{24,7 \cdot 435} = 9 \text{ mm}^2/\text{m}$$

A practical reinforcement made of an orthogonal mesh bars $\phi 6$ -200 mm applied at mid-height of the slab, is by far sufficient.

3.2.3.3 Shear capacity

Bearing beam in axis B

In the bearing beam axis, adjacent to the intermediate support (axis 2) the maximum shear force is $V_{Ed} = 270,73$ kN (see Chapter 2). In the governing section at distance d from the support this value is reduced to $V_{Ed,red} = 240$ kN. If this is larger than $V_{Rd,c}$ (see Eqn. 3.18) calculated shear reinforcement is required. Here

$$k = 1 + \sqrt{\frac{200}{d}} = 1 + \sqrt{\frac{200}{360}} = 1,74$$

$$\rho_l = \frac{A_{sl}}{bd} = \frac{2010}{250 \cdot 360} = 0,022 \leq 0,02$$

$$V_{Rd,c} = 0,12 \cdot 1,74 \cdot (100 \cdot 0,02 \cdot 16,7)^{1/3} 250 \cdot 360 \cdot 10^{-3} = 69 \text{ kN}$$

is smaller than the design shear force of 270,73 kN: shear reinforcement has to be provided. Assuming an inclination angle with $\cot\theta = 2.5$ the required shear reinforcement follows from Eqn. 3.19.

$$V_{Rd,s} = V_{Ed} \Rightarrow \frac{A_{sw}}{s} = \frac{V_{Ed}}{z f_{ywd} \cot\theta}$$

$$a_{sw} = \frac{A_{sw}}{s} = \frac{240 \cdot 1000}{0,82 \cdot 375 \cdot 435 \cdot 2,5} = 0,72 \text{ mm}^2/\text{mm}$$

Stirrups $\phi 10/175$ mm ($0,89 \text{ mm}^2 / \text{mm}$) are adequate.

Bearing ribs with embedded elements

The maximum shear force in the ribs follows from Figure 3.2.42. $V_{Ed,red}$ at a distance d ($=190$ mm) from the edge of the supporting beam (see also Figure 3.2.42) is

$$\frac{44,2}{4,45} = \frac{V_{Ed,red}}{(4,45 - 0,19 - 0,125)} \Rightarrow V_{Ed,red} = 41,1 \text{ kN.}$$

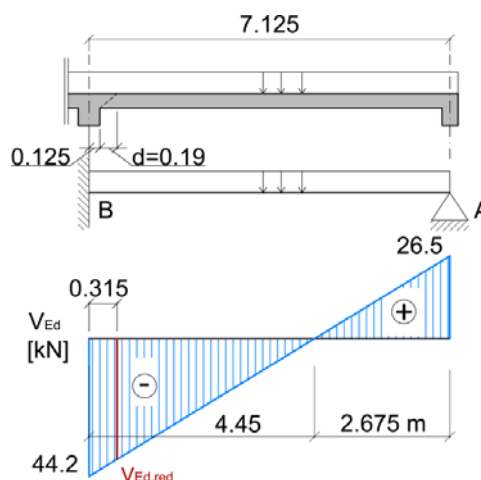

Fig. 3.2.42 Distribution of shear force along rib of slab with embedded lighting elements

$$V_{Rd,c} = [C_{Rd,c} k (100 \rho_l f_{ck})^{\frac{1}{3}}] b_w d$$

where

$$C_{Rd,c} = \frac{0,18}{\gamma_c} = \frac{0,18}{1,5} = 0,12$$

$$k = 1 + \sqrt{\frac{200}{d}} \leq 2,0 \quad k = 1 + \sqrt{\frac{200}{190}} = 2,02 > 2,0 \rightarrow k = 2,0$$

$$V_{Rd,c} = [0,12 \cdot 2,0 \cdot (100 \cdot 0,02 \cdot 25)^{\frac{1}{3}}] \cdot 240 \cdot 190 \cdot 10^{-3} = 40,2 \text{ kN}$$

$$V_{Rd,c} = 40,2 \text{ kN} < V_{Ed,red} \approx 41,1 \text{ kN} \Rightarrow$$

This 2% lower than the design shear value can, reasonably, be ignored. In order that that the slab with embedded lighting elements is formally regarded as a slab, the rule in *clause 5.3.1(6)* (“*Transverse ribs are provided at a clear spacing not exceeding 10 times the overall depth of the slab*”) gives a distance of $10 \cdot 230 = 2300$ mm. One transverse rib is actually provided at distance $7,125/2 = 3,56 > 2,30$ m so two ribs at a distance $7,125/3 = 2,38 \approx 2,30$ m should preferably be provided.

Slab with embedded elements

The design shear stress at the fixed ends is $v_{Ed} = (0,190 \cdot 8460)/(1000 \cdot 25) = 0,06$ N/mm², far below $v_{Rd,c}$.

3.3 Serviceability limit states

3.3.1. SLS deflection - general

The control of deflection can be done

- by calculation or
- by tabulated values

3.3.1.1 Deflection control by calculation

For span-depth ratios below 7,5 m the following limits according to *chapter 7.4.2 (EC 2)* no further checks are needed.

$$\frac{l}{d} = K \left[11 + 1,5 \sqrt{f_{ck}} \frac{\rho_0}{\rho} + 3,2 \sqrt{f_{ck}} \left(\frac{\rho_0}{\rho} - 1 \right)^{3/2} \right] \quad \text{if } \rho \leq \rho_0 \quad (3.48)$$

$$\frac{l}{d} = K \left[11 + 1,5 \sqrt{f_{ck}} \frac{\rho_0}{\rho - \rho'} + \frac{1}{12} \sqrt{f_{ck}} \sqrt{\frac{\rho'}{\rho_0}} \right] \quad \text{if } \rho > \rho_0 \quad (3.49)$$

where

l/d is the limit span/depth,

K is the factor to take into account the different structural systems,

ρ_0 is the reference reinforcement ratio $= \sqrt{f_{ck}} \cdot 10^{-3}$,

ρ is the required tension reinforcement ratio at mid span to resist the moment due to the design loads (at support for cantilevers) and

ρ' is the required compression reinforcement ratio at mid span to resist the moment due to design loads (at support for cantilevers).

Figure 3.3.2 shows the previous expressions in a graphical form assuming $K = 1$.

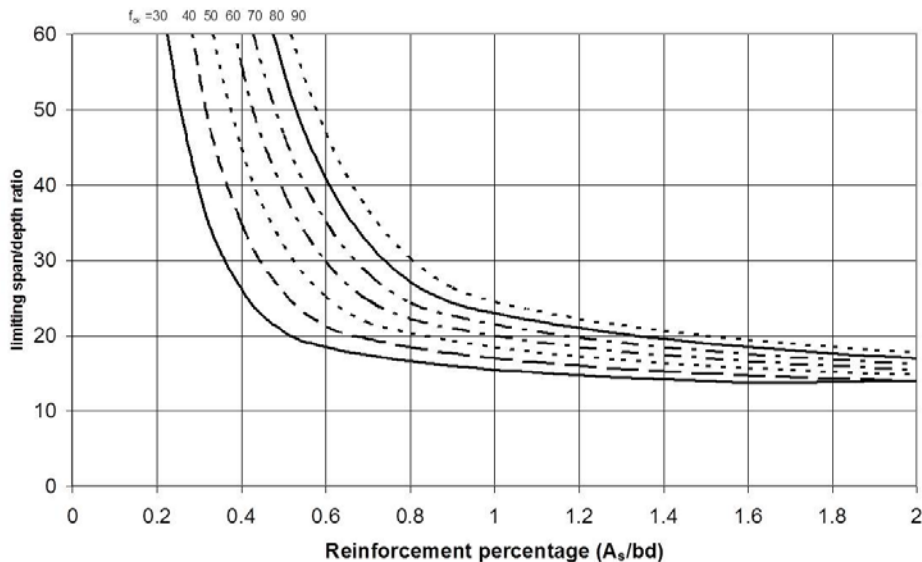

Fig. 3.3.1 Eqn. 7.16a/b EC 2

Eqn.(3.49) and Eqn.(3.50) are based on many different assumptions (age of loading, time or formwork removal, temperature, humidity, creep effects) and represent a conservative approach. The coefficient K depends on the static system of the structure - Figure 3.3.1.

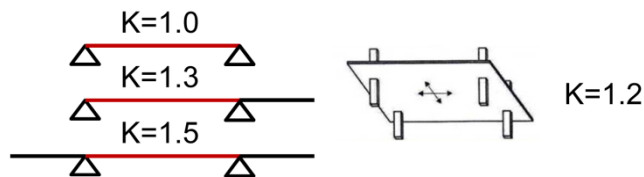

Fig. 3.3.2 Coefficient K depending on the static system

The expressions have been derived for an assumed stress in the reinforcing steel at mid span stress $\sigma_s = 310 \text{ N/mm}^2$. σ_s has to be evaluated under the quasi permanent load combination. If another stress level is applied or if more reinforcement than minimum required is provided, the values obtained by Eqn.(3.49) and (3.50) can be multiplied with the factor

$$\frac{310}{\sigma_s} = \frac{500}{f_{yk} A_{s,req} / A_{s,prov}} \quad (3.50)$$

There are rules for spans larger than 7,5 m in Chapter 7.4.2 (EC 2):

- For beams and slabs (no flat slabs) with spans larger than 7 m, which support partitions liable to damage by excessive deflections, the values l/d given by Eqn. (7.16) in the EC 2 should be multiplied by $7/l_{eff}$ (l_{eff} in meters).
- For flat slabs where the greater span exceeds 8,5 m, and which support partitions to be damaged by excessive deflections, the values l/d given by expression (7.16) in the EC 2 should be multiplied by $8,5/l_{eff}$.

3.3.1.2 Tabulated K values and basic ratios (l/d)

Table 3.3.1 gives the K values (Eqn. 7.16 – EC 2), corresponding to the different structural system and the slenderness' limits (l/d) values for relatively high ($\rho=1,5\%$) and low ($\rho=0,5\%$) longitudinal reinforcement ratios at mid-span. These values, calculated for concrete quality C30/37 and $\sigma_s = 310$ N/mm², and satisfy the deflection limits given in chapter 7.4.1 (4) and (5) in EC 2.

Table 3.3.1 Tabulated values for l/d

Structural system	Factor K	l/d	
		$\rho = 1,5 \%$	$\rho = 0,5 \%$
Simply supported slab/beam	1,0	14	20
End span	1,3	18	26
Interior span	1,5	20	30
Flat slab	1,2	17	24
Cantilever	0,4	6	8

3.3.1.3 Slab on beams

For the ULS design the transmission of loads to the bearing beams has been assumed in the approximate way shown in Figure 3.2.18. This leads to a distribution of the bending reinforcement as in Figure 3.2.19. For the control of the deflection the strip is considered spanning between the mean beams at axes 1 and 2, with a required reinforcement of 0,44% (in the left of Figure 3.2.19 spanning from left to right). In the case of a two-way spanning slab, the check has to be carried on the basis of the shorter span ($l = 6,00$ m) and the related reinforcement.

According to EC 2, Chapter 7.4.2, the span to depth ratio l/d should satisfy Eqn.7.16a (see also Eqn.3.49 in this report).

Assuming $A_{s,req} = A_{s,prov}$, $f_{ck} = 25$ MPa, $\rho_0 = 10^{-3} \sqrt{f_{ck}} = 0,005$, $\rho = 0,0044$ and $K = 1,3$ (end-span):

$$\frac{l}{d} = 1,3 \cdot \left[11 + 1,5 \cdot \sqrt{25} \cdot \frac{0,5}{0,44} + 3,2 \cdot \sqrt{25} \cdot \left(\frac{0,5}{0,44} - 1 \right)^{3/2} \right] = 1,3 \cdot [11 + 8,5 + 0,80] = 26,4$$

This relation is valid for a default steel stress $\sigma_s = 310$ MPa. Deflection control is made for the quasi-permanent load condition when the total load is $(G_1 + G_2 + \psi_2 Q_k) = 4,5 + 3,0 + 0,3 \cdot 2 = 8,1$ kN/m². Differently from ULS, in SLS conditions the variable load is present on both spans, so the bending moment $M_{Ek} = 8,1 \cdot 6,0^2 / 14,2 = 20,5$ kN/m while $M_{Ed} = 36,95$ kNm. As the depth of the neutral axis does not differ that much in ULS and SLS conditions, the steel stress under the quasi-permanent load) may be assumed as:

$$\sigma_s = \frac{M_{Ek}}{M_{Ed}} f_{yd} = \frac{20,5}{36,95} \cdot 435 = 241 \text{ MPa}$$

Therefore the allowable l/d ratio may be increased to:

$$\frac{l}{d} = \frac{310}{241} \cdot 26,4 = 33,9$$

The actual span-depth ratio is

$$\frac{l}{d} = \frac{6000 - 100 - 125}{144} = 40,1 > 33,9.$$

The effective reinforcement area should therefore be at least $(40,1/33,9) - 1 = 18\%$ higher than the theoretical 0,44%, one, i.e. $44 \cdot 1,18 = 0,52\%$ and the coefficient $A_{s,req} / A_{s,prov} = 1,18$ should be considered. Increasing the quantity of steel in turns reduces the steel stress and guarantees the deflection control is satisfied.

As an alternative, the refined calculation method could be used (*Chapter 7.4.3 EC2*).

3.3.1.4 Flat slab

For the ULS the reinforcement has been calculated assuming a total slab thickness of 210 mm, 30 mm higher than in the previous case.

For a flat slab with a relatively low reinforcement ratio ($\rho = 0,5\%$) Table 3.3.1 gives a span-depth ratio $l/d = 24$. In Chapter 3.2.2 the ULS calculated bending reinforcement in the Y-direction at mid-span A-B was 0,56%. This means that the mentioned value $l/d = 24$ should be almost OK. It may be assumed that, even if the models are different (slabs on beams vs flat slab), the steel stress ratio under the quasi-permanent load condition does not differ from the previous one, so the allowable l/d ratio can be assumed to be

$$\frac{l}{d} = \frac{310}{241} \cdot 24 = 30,9$$

For flat slab the longer span $l_y = 7125 - 125 - 100 = 6900$ mm has to be considered, so the actual ratio of l/d is:

$$\frac{l}{d} = \frac{6900}{172} = 40,1$$

That means that, as in the previous case, a $(40,1/30,9) - 1 = 30\%$ increase of the longitudinal reinforcement is required, i.e. the effective reinforcement should be $0,5 \cdot 1,30 = 0,65 > 0,56\%$. As an alternative, a refined calculation could to be considered.

3.3.1.5 Slab with embedded elements

The reinforcement ratio at mid-span is

$$\rho = \frac{A_{s,l}}{bd} = \frac{226}{500 \cdot 197} = 0,23 \cdot 10^{-2}$$

The ribbed slab has a T section with $b = 500$ mm and $b_w = 120$ mm then $b/b_w = 4,16 > 3$ which introduces a reduction factor 0,80 in the formulae. According to *chapter 7.4.2 (2) – EC 2* no detailed calculation is necessary if the l/d ratio of the slab is smaller than the limit value:

$$\frac{l}{d} = 0,80 \cdot 1,3 \cdot \left[11 + 1,5 \cdot \sqrt{25} \cdot \frac{0,5}{0,23} + 3,2 \cdot \sqrt{25} \cdot \left(\frac{0,5}{0,23} - 1 \right)^{3/2} \right] = 0,80 \cdot 1,3 \cdot [11 + 16,3 + 20,4] = 49,6$$

In this case it not necessary to consider neither the steel stress/310 nor the $A_{s,req}/A_{s,prov}$ coefficients as the actual value of l/d is :

$$\frac{l}{d} = \frac{7125}{197} = 36,2 < 49,6$$

3.3.2. SLS crack width - general

The crack width is the difference between the steel and concrete elongations over the length ($2l_t$), where l_t is the “transmission length” necessary to increase the concrete strength from 0 to the tensile strength f_{ctm} (Figure 3.3.3): the maximum distance between two cracks has to be $2l_t$ otherwise a new crack could occur in-between (see Figure 3.3.3)

It can be demonstrated that the transmission length l_t is equal to:

$$l_t = \frac{1}{4} \frac{f_{ctm}}{T_{bm}} \frac{\sigma}{\rho} \quad (3.51)$$

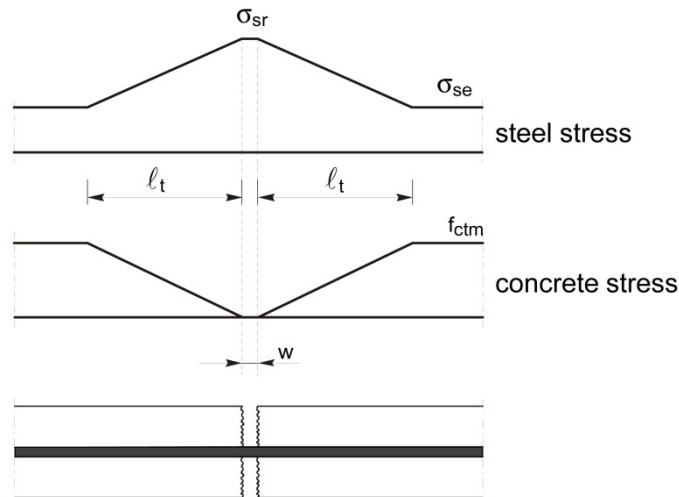

Fig. 3.3.3 Definition of the crack width

For the calculation of the maximum (or characteristic) crack width, the difference between steel and concrete elongations has to be calculated for the largest crack distance $s_{r,max} = 2l_t$. The formula for crack width control according to *clause 7.3.4 Eqn. (7.8) – EC 2* is:

$$w_k = s_{r,max} (\epsilon_{sm} - \epsilon_{cm}) \quad (3.52)$$

where

$s_{r,max}$ is the maximum crack distance

$(\epsilon_{sm} - \epsilon_{cm})$ is the difference in deformation between steel and concrete over the maximum crack distance.

Formulations for $s_{r,max}$ and $(\epsilon_{sm} - \epsilon_{cm})$ are given in the formula in *clause 7.3.4 Eqn. (7.9) – EC 2*:

$$(\varepsilon_{sm} - \varepsilon_{cm}) = \frac{\sigma_s - k_t \frac{f_{ct,eff}}{\rho_{p,eff}} (1 + \alpha_e \rho_{p,eff})}{E_s} \geq 0,6 \frac{\sigma_s}{E_s} \quad (3.53)$$

where

σ_s is the stress in the steel assuming a cracked section,

α_e is the moduli ratio E_s / E_{cm} ,

$\rho_{p,eff} = \frac{(A_s + \xi A_p)}{A_p}$ is the effective reinforcement ratio (including eventual prestressing steel A_p)

ξ is the moduli ratio E_s / E_{cm}

k_t is a factor depending on the duration of load (0,6 for short and 0,4 for long term loads).

For the crack spacing $s_{r,max}$ a modified expression has been derived, including the concrete cover. From experimental observations the crack at the outer concrete surface is wider than at the reinforcing steel level. Moreover, cracks are always measured at the surface of the structure (see Figure 3.3.4).

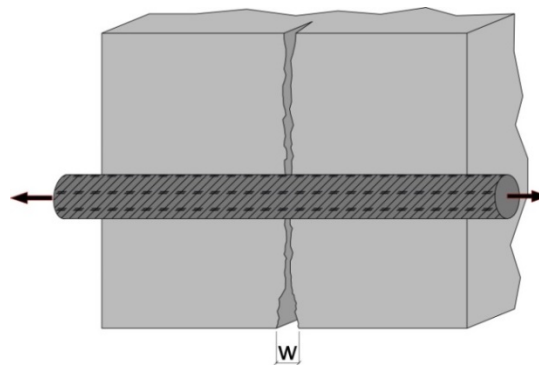

Fig. 3.3.4 Measured crack width w

The maximum final crack spacing $s_{r,max}$ according to *clause 7.3.4 Eqn. (7.11) – EC 2* is given by:

$$s_{r,max} = k_3 c + k_1 k_2 k_4 \frac{\phi}{\rho_{p,eff}} \quad (3.54)$$

where

c is the concrete cover,

ϕ is the bar diameter,

k_1 is the bond factor (0,8 for high bars, 1,6 for bars with an effectively plain surface, e.g. prestressing tendons),

k_2 is the strain distribution coefficient (1,0 for tension and 0,5 for bending: intermediate values can be used),

k_3 is recommended to be 3,4 and

k_4 is recommended to be 0,425.

In order to apply the crack width formulae, basically established for a concrete bar in tension, to a structure under bending, a definition of the “effective tensile bar height” is necessary. This effective height $h_{c,ef}$ is the minimum of:

$$2,5 (h-d) \quad \text{or} \quad (h-x)/3 \quad \text{or} \quad h/2.$$

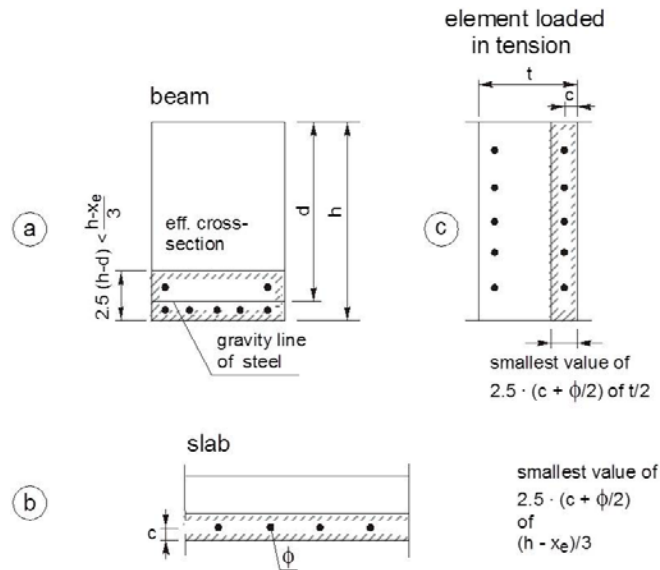

Fig. 3.3.5 Effective tensile bar height according to EC 2

Table 3.3.2 shows the EC 2 requirements for the crack width control (recommended values).

Table 3.3.2 Recommended values for crack width control

	Exposure class		Prestressed members with bonded tendons
	Quasi-permanent load		Frequent load
X0, XC1	0,3		0,2
XC2, XC3, XC4			
XD1, XD2, XS1, XS2, XS3	0,3		Decompression

3.3.2.1 Crack width control – slab with embedded elements

Internal support

Assuming concentric tension in the upper slab of 50 mm depth (see Figure 3.3.7) leads to the following calculation.

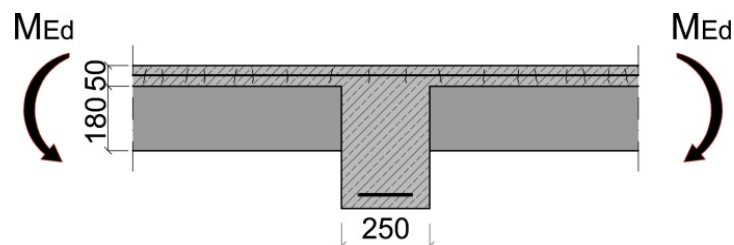

Fig. 3.3.7 Geometry and bending moments

The steel stress $\sigma_{s,qp}$ under the quasi-permanent load and the reinforcement ratio are: :

$$\sigma_{s,qp} = \frac{Q_{qp}}{Q_{Ed}} \frac{A_{s,req}}{A_{s,prov}} f_{yd} = 0,597 \cdot 0,73 \cdot 435 = 190,2 \text{ N/mm}^2$$

$$\rho_{s,eff} = \frac{A_{sl}}{bd} = \frac{1256}{1000 \cdot 50} = 2,51\%$$

The crack distance (according to Eqn.(3.55)) is

$$s_{r,max} = 3,4 \cdot 19 + 0,8 \cdot 1,0 \cdot 0,425 \cdot \frac{20}{0,0251} = 335,3 \text{ mm}$$

The average strain (according to Eqn.(3.54)) amounts to

$$\varepsilon_{sm} - \varepsilon_{cm} = \frac{190,2 - 0,4 \cdot \frac{2,6}{0,0251} \cdot (1 + 7 \cdot 0,0251)}{200000} = 0,71 \cdot 10^{-3} > 0,57 \cdot 10^{-3}$$

The characteristic crack width (according to Eqn. (3.53)) is

$$w_k = s_{r,max} (\varepsilon_{sm} - \varepsilon_{cm}) = 335,3 \cdot 0,71 \cdot 10^{-3} = 0,24 < 0,30 \text{ mm}$$

Mid-span

The steel stress $\sigma_{s,qp}$ under the quasi-permanent load and the reinforcement ratio are:

$$\sigma_{s,qp} = \frac{Q_{qp}}{Q_{Ed}} \frac{A_{s,req}}{A_{s,prov}} f_{yd} = 0,597 \cdot 1,04 \cdot 435 = 270 \text{ N/mm}^2$$

$$\rho_{s,eff} = \frac{A_{sl}}{bh_{eff}}$$

For h_{eff} , the smallest of $2,5(h-d)$, $(h-x) / 3$ or $h / 2$ should be chosen. The critical value for h_{eff} is: $2,5(h-d)=2,5 \cdot 33=82,5 \text{ mm}$.

$$\rho_{s,eff} = \frac{226}{120 \cdot 82,5} = 2,28\%$$

The crack distance according to Eqn.(3.55) is

$$s_{r,max} = 3,4 \cdot 29 + 0,8 \cdot 0,5 \cdot 0,425 \cdot \frac{12}{0,0228} = 188,1 \text{ mm}$$

The average strain (according to Eqn.(3.54)) amounts to

$$\varepsilon_{sm} - \varepsilon_{cm} = \frac{270 - 0,4 \cdot \frac{2,6}{0,0228} \cdot (1 + 7 \cdot 0,0228)}{200000} = 1,09 \cdot 10^{-3} > 0,81 \cdot 10^{-3} \Rightarrow \text{ok!}$$

The characteristic crack width according to Eqn. (3.53) is

$$w_k = s_{r,\max} (\varepsilon_{sm} - \varepsilon_{cm}) = 188,1 \cdot 1,09 \cdot 10^{-3} = 0,20 \text{ mm} < 0,30 \text{ mm}.$$

References

Zilch, K., and G. Zehetmaier. 2010. *Bemessung im konstruktiven Betonbau, nach DIN 1045-1 (Fassung 2008) und EN 1992-1-1 (Eurocode 2)*. Springer Verlag.

CHAPTER 4

DETAILING OF THE REINFORCEMENT

Jose ARRIETA

PROES S.A., Spain

4.1 Detailing - general

EN 1992-1-1 Section 8 is dedicated to detailing rules for ribbed reinforcement, meshes and prestressing tendons subjected predominantly to static loading. Different rules than those in *Eurocode 2* apply to reinforcement of buildings in seismic zones.

Section 8.2 defines the minimum bar spacing required to guarantee a good placing and compaction of concrete, to grant adequate bond. Table reports the minimum spacing $s_{min} = (d_g + 5)$ mm for each bar diameter, assuming the maximum aggregate size $d_g = 20$ mm.

To bend a bar avoiding cracks in the bar and/or failure of the concrete inside the bend a minimum diameter of the mandrel $\phi_{m,min}$ is required in *Section 8.3*. For each bar diameter in Table 4.1.1 the mandrel diameter $\phi_{m,min}$ is given, assuming that provisions in *Section 8.3 (3)* are fulfilled.

Table 4.1.1. Minimum spacing and mandrel diameter

ϕ (mm)	s_{min} (mm)	$\phi_{mand,min}$ (mm)
8	25	32
10	25	40
12	25	48
14	25	56
16	25	64
20	25	140
25	25	175

4.1.1. Anchorage length

To avoid longitudinal cracks and spalling of concrete the anchorage of longitudinal reinforcement has to satisfy the conditions given in *Section 8.4*. Applying these provisions are obtained the anchorage lengths in Table 4.1.2, Table 4.1.3 and Table 4.1.4 for structural elements of the building subjected to several conditions:

- Tension or compression
- Good or poor bond conditions (related to concreting)
- Straight anchorage or standard bend, hook or loop

The design anchorage length l_{bd} has been calculated for straight bars; for standard bends, hooks or loops, the simplified procedure described in *clause 8.4.4 (2)*, based on the equivalent anchorage length $l_{b,eq}$ has been used.

For standard bends or hooks, table data are based on the assumption $s_{min} \geq 2c_{nom}$. Confinement by transverse reinforcement or transverse pressure was neglected.

Table 4.1.2. Anchorage lengths for FOOTINGS (C25/30 $c_{nom} = 40$ mm)

ϕ (mm)	$l_{b,d}$ straight anchorage (mm)				$l_{b,eq}$ standard bend, hook or loop (mm)			
	Tension		Compression		Tension		Compression	
	Good	Poor	Good	Poor	Good	Poor	Good	Poor
8	226	323	323	461	226	323	226	323
10	283	404	404	577	283	404	283	404
12	339	484	484	692	339	484	339	484
14	408	582	565	807	565	807	565	807
16	500	715	646	922	646	922	646	922
20	686	980	807	1153	807	1153	807	1153
25	918	1312	1009	1441	1009	1441	1009	1441

Table 4.1.3. Anchorage lengths for BEAMS AND SLABS (C25/30 $c_{nom} = 30$ mm)

ϕ (mm)	$l_{b,d}$ straight anchorage (mm)				$l_{b,eq}$ standard bend, hook or loop (mm)			
	Tension		Compression		Tension		Compression	
	Good	Poor	Good	Poor	Good	Poor	Good	Poor
8	226	323	323	461	226	323	226	323
10	283	404	404	577	404	577	404	577
12	375	536	484	692	484	692	484	692
14	468	669	565	807	565	807	565	807
16	561	801	646	922	646	922	646	922
20	747	1067	807	1153	807	1153	807	1153
25	979	1398	1009	1441	1009	1441	1009	1441

Table 4.1.4. Anchorage lengths for COLUMNS (C30/37 $c_{nom} = 30$ mm)

ϕ (mm)	$l_{b,d}$ straight anchorage (mm)				$l_{b,eq}$ standard bend, hook or loop (mm)			
	Tension		Compression		Tension		Compression	
	Good	Poor	Good	Poor	Good	Poor	Good	Poor
8	200	286	286	408	200	286	200	286
10	250	357	357	511	357	511	357	511
12	332	475	429	613	429	613	429	613
14	415	592	500	715	500	715	500	715
16	497	710	572	817	572	817	572	817
20	661	945	715	1021	715	1021	715	1021
25	867	1238	893	1276	893	1276	893	1276

Regarding the anchorage of links and of shear reinforcement using bends and hooks, the provisions in *clause 8.5* result in the length after the curved part l_{link} in Table 4.1.5.

Table 4.1.5. Length after the curved part for links

ϕ (mm)	l_{link} (mm)	
	Bend	Hook
6	70	50
8	80	50
10	100	50
12	120	60

4.1.2. Lap length

The transmission of forces between the bars may be obtained using laps. To avoid the spalling of concrete and/or large cracks, the laps should be staggered far from high moments/forces zones and symmetrically arranged in any section. Using provisions in *clause 8.7* the lap lengths l_o for beams, slabs and columns (Tables 4.1.6, 4.1.7, 4.1.8 and 4.1.9) have been determined for the following conditions:

- Tension or compression
- Good or poor bond conditions related to concreting
- Different percentages ρ_1 of lapped bars in a zone around the selected bar lap

Table 4.1.6 Lap lengths for BEAMS AND SLABS (C25/30 $c_{nom} = 30$ mm) - TENSION

ϕ (mm)	Lap length l_o (mm)							
	Good bond conditions				Poor bond conditions			
	$\rho_1 < 25$	$\rho_1 = 33$	$\rho_1 = 50$	$\rho_1 > 50$	$\rho_1 < 25$	$\rho_1 = 33$	$\rho_1 = 50$	$\rho_1 > 50$
8	226	260	316	339	323	371	452	484
10	283	325	396	424	404	464	565	605
12	375	432	525	563	536	617	751	804
14	468	538	655	702	669	769	936	1003
16	561	645	785	841	801	922	1122	1202
20	747	859	1045	1120	1067	1227	1493	1600
25	979	1126	1370	1468	1398	1608	1957	2097

Table 4.1.7 Lap lengths for BEAMS AND SLABS (C25/30 $c_{nom} = 30\text{mm}$) - COMPRESSION

ϕ (mm)	Lap length l_o (mm)							
	Good bond conditions				Poor bond conditions			
	$\rho_l < 25$	$\rho_l = 33$	$\rho_l = 50$	$\rho_l > 50$	$\rho_l < 25$	$\rho_l = 33$	$\rho_l = 50$	$\rho_l > 50$
8	323	371	452	484	461	530	646	692
10	404	464	565	605	577	663	807	865
12	484	557	678	726	692	796	969	1038
14	565	650	791	848	807	928	1130	1211
16	646	743	904	969	922	1061	1291	1384
20	807	928	1130	1211	1153	1326	1614	1730
25	1009	1160	1413	1513	1441	1658	2018	2162

Table 4.1.8 Lap lengths for COLUMNS (C30/37 $c_{nom} = 30\text{mm}$) – TENSION

ϕ (mm)	Lap length l_o (mm)							
	Good bond conditions				Poor bond conditions			
	$\rho_l < 25$	$\rho_l = 33$	$\rho_l = 50$	$\rho_l > 50$	$\rho_l < 25$	$\rho_l = 33$	$\rho_l = 50$	$\rho_l > 50$
8	200	230	280	300	286	329	400	429
10	250	288	350	375	357	411	500	536
12	332	382	465	499	475	546	665	712
14	415	477	580	622	592	681	829	888
16	497	571	695	745	710	816	994	1065
20	661	760	926	992	945	1086	1322	1417
25	867	997	1213	1300	1238	1424	1733	1857

Table 4.1.9 Lap lengths for COLUMNS (C30/37 $c_{nom} = 30\text{mm}$) – COMPRESSION

ϕ (mm)	Lap length l_o (mm)							
	Good bond conditions				Poor bond conditions			
	$\rho_l < 25$	$\rho_l = 33$	$\rho_l = 50$	$\rho_l > 50$	$\rho_l < 25$	$\rho_l = 33$	$\rho_l = 50$	$\rho_l > 50$
8	286	329	400	429	408	470	572	613
10	357	411	500	536	511	587	715	766
12	429	493	600	643	613	705	858	919
14	500	575	701	751	715	822	1001	1072
16	572	658	801	858	817	939	1144	1225
20	715	822	1001	1072	1021	1174	1430	1532
25	893	1028	1251	1340	1276	1468	1787	1915

If the diameter of the lapped bars is ≥ 20 mm and the percentage ρ_l of lapped bars is $\geq 25\%$, transverse reinforcement is required (*clause 8.7.4*). Otherwise, any transverse reinforcement or links necessary for other reasons may be considered sufficient for the transverse tensile forces without further justification.

4.2 Detailing of structural members

Section 9 of EN 1992-1-1 establishes rules to satisfy the safety, serviceability and durability requirements. Minimum and maximum reinforcement areas are defined to avoid concrete brittle failure and/or formation of wide cracks, and to resist forces coming for restrained actions.

4.2.1. Detailing of footing B-2

The columns of the building have direct concrete footings with total depth 800 mm which geometry is shown on Figure 4.2.1.

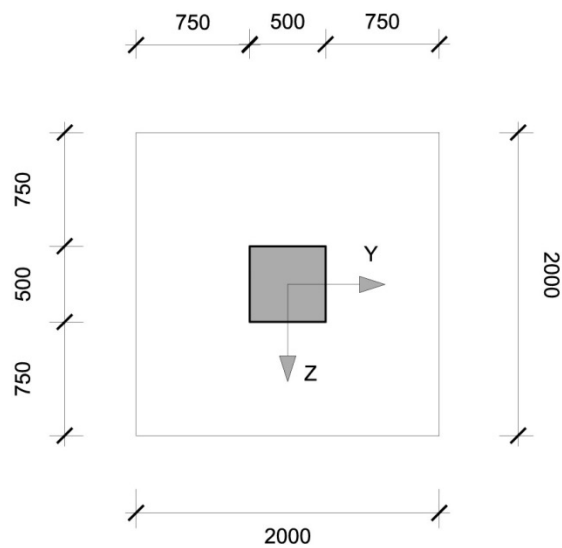

Fig.4.2.1 Definition of the footing

4.2.1.1 Design of the footing

To design and verify footing B-2, the soil pressures for ULS determined in the geotechnical part for the verification of the bearing capacity of the soil, was used. These pressures were obtained from the analytical method described in EN 1997-2 Annex 1.

Figure 4.2.2 and the following equations summarize the mentioned model and allow to evaluate the soil pressure at the base of the foundation for the ULS action effects N_{Ed} , $M_{Ed,y}$ and $M_{Ed,z}$.

$$\sigma_{Ed} = \frac{N_{Ed}}{B' L'} \begin{cases} L' = L - 2e_L \text{ and } e_L = -\frac{M_{Ed,z}}{|N_{Ed}|} \\ B' = L - 2e_B \text{ and } e_B = \frac{M_{Ed,y}}{|N_{Ed}|} \end{cases}$$

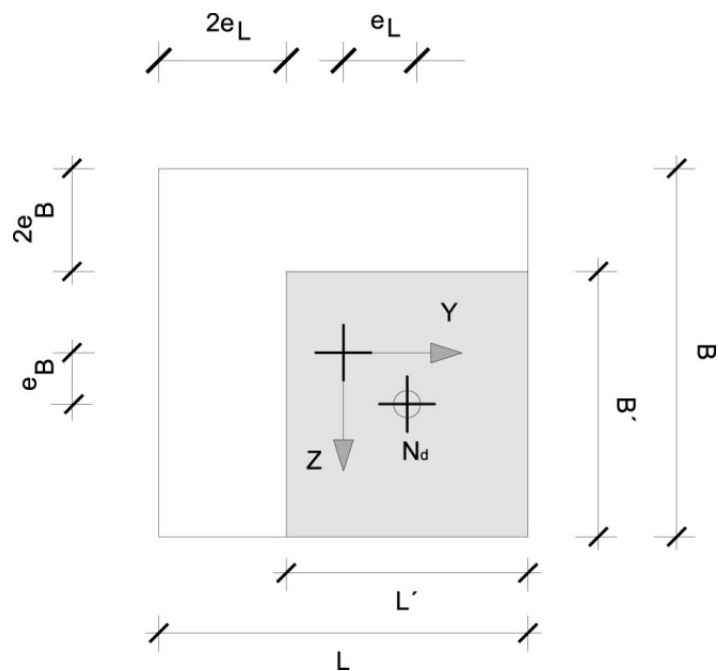

Fig.4.2.2 Model for the bearing resistance calculation

Table 4.2.1 includes the mentioned internal forces and the eccentricities in each direction. As it can be seen the eccentricities are very low (less than 1 mm) and we will consider them as zero.

Table 4.2.1 Internal forces and eccentricities at ULS

Combination	N_{Ed} (kN)	$M_{Ed,y}$ (kNm)	$M_{Ed,z}$ (kNm)	e_L (mm)	e_B (mm)
1	-4554,80	3,82	-3,78	0,8	0,8
2	-4837,96	-3,11	0,60	-0,1	-0,6
3	-4990,35	-2,71	0,66	-0,1	-0,5
4	-4985,91	-3,26	-2,31	0,5	-0,7
5	-4491,62	-2,73	-1,38	0,3	-0,6
6	-5435,54	-2,98	-3,46	0,6	-0,5
7	-5359,70	1,44	0,71	-0,1	0,3
8	-5359,70	1,44	0,71	-0,1	0,3
9	-4502,78	4,08	-3,50	0,8	0,9
10	-5780,18	-2,36	-4,49	0,8	-0,4

The highest soil pressure is:

$$\sigma_{Ed} = \frac{N_{Ed}}{B'L'} = \frac{5780,18}{2,00 \cdot 2,00} = 1445 \text{ kN/m}^2$$

In order to design the bottom reinforcement area in the footing, the approach in *clause 9.8.2.2 of EN 1992-1-1* for the anchorage of the bars provides the maximum force in the reinforcement. The effective pressure σ'_{Ed} has to be considered to calculate the reinforcement of the footing subjected to the soil pressure and to its self-weight (Figure 4.2.3).

$$\sigma'_{Ed} = \sigma_{Ed} - q_{sw,d} = 1445 - 1,35 \cdot 25 \cdot 0,80 = 1418 \text{ kN/m}^2$$

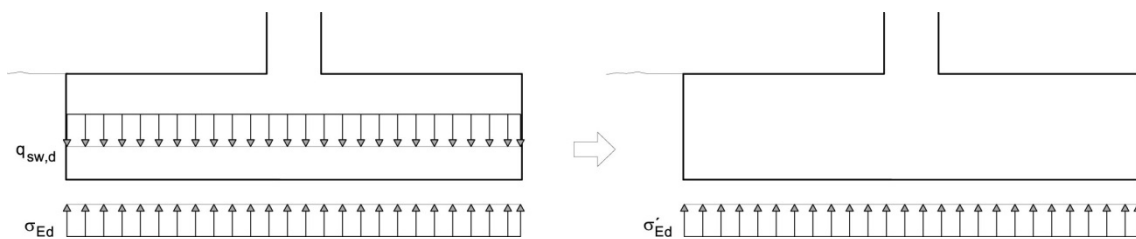

Fig.4.2.3 Effective pressure

Figure 4.2.4 and the following equations describe how to define the anchorage of the bars: assuming $x = b/2 - 0,35a$ the maximum tensile force on the reinforcement is obtained.

$$F_s(x) = R_d(x) \frac{z_e(x)}{z_i} \quad \text{being} \quad \begin{cases} z_e(x) = \frac{b}{2} - 0,35a - \frac{x}{2} \\ R_d(x) = \sigma'_{Ed} b' x \end{cases}$$

$$F_{s,max} = F_s\left(\frac{b}{2} - 0,35a\right)$$

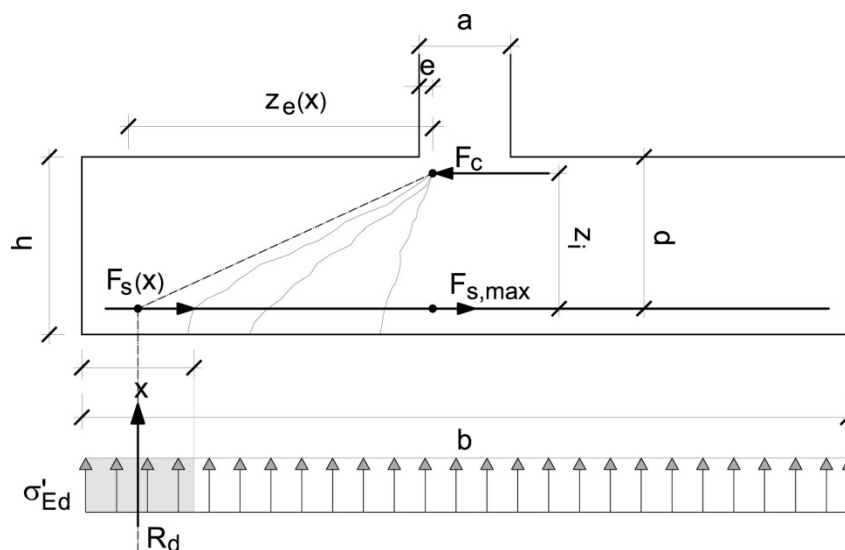

Fig.4.2.4 Model for tensile forces in cracks

The main characteristics of the footing are:

Concrete: C25/30	Steel: B500
$a = 500 \text{ mm}$	$e = 0,15a = 75 \text{ mm [9.8.2.2 (3)]}$
$b = b' = 2000 \text{ mm}$	$h = 800 \text{ mm}$
$c_{nom} = 40 \text{ mm}$	$d = h - c_{nom} - 1,5\phi = 736 \text{ mm (assuming } \phi = 16 \text{ mm)}$
$z_i = 0,90d = 662 \text{ mm (assuming } \phi = 16 \text{ mm) [9.8.2.2 (3)]}$	

Substituting the footing characteristics, the expression for the tensile force in the reinforcement

$$F_s(x) = 2836 \cdot x \cdot \frac{0,825 - 0,5x}{0,662}$$

The maximum value of the tensile force $F_{s,max}$ and the needed area of the reinforcement A_s are:

$$F_{s,max} = F_s(0,825) = 1457,9 \text{ mm}^2 \Rightarrow$$

$$A_s = \frac{F_{s,max}}{f_{yk}/\gamma_s} = 3353 \text{ mm}^2 \Rightarrow 17\phi 16$$

4.2.1.2 Arrangement of the reinforcement

The minimum bar diameter to be used in a footing is 8 mm [9.8.2.1 (1)], so the provided reinforcement is correct. The clear distance between bars is 98 mm (Figure 4.2.5) greater than $s_{min} = 25 \text{ mm}$ (see Table 4.1.1).

To verify the conditions of the bar straight anchorage, it has to be verified that

$$l_b + c_{nom} < x_{min}$$

where x_{min} is the distance of the first crack located [9.8.2.2 (5)] at distance $x_{min} = h/2$. From Table 4.1.2 the design anchorage length in case of tensile force and good bond conditions is $l_{bd} = 500 \text{ mm}$.

$$F_s(x_{min}) = F_s(0,40) = 1071,0 \text{ kN} \Rightarrow$$

$$l_b = \frac{F_s(x_{min})}{A_s f_{yd}} l_{bd} = \frac{1071,0}{1485,7} \cdot 500 = 360 \text{ mm}$$

$$l_b + c_{nom} = 400 \text{ mm} \leq x_{min} = 400 \text{ mm}$$

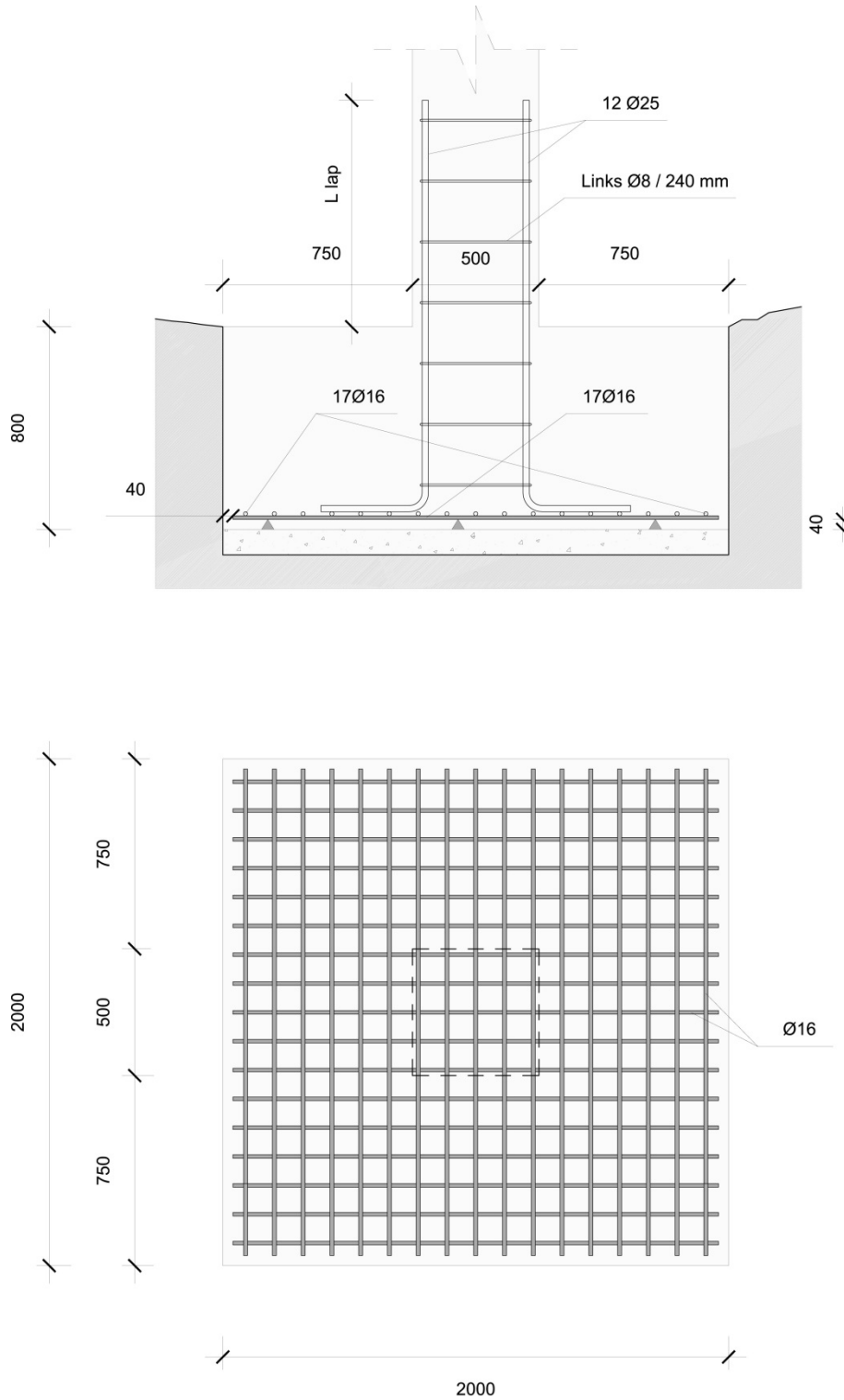

Fig.4.2.5 Reinforcement of the footing

Figure 4.2.6 shows the actual force in the reinforcement $F_{s,Ed}$ (action) as a function of x and the capacity of the reinforcement $F_{s,Rd}$ (resistance) taking into account the anchorage. From the distance x_{min} of the first crack is always $F_{s,Rd} > F_{s,Ed}$.

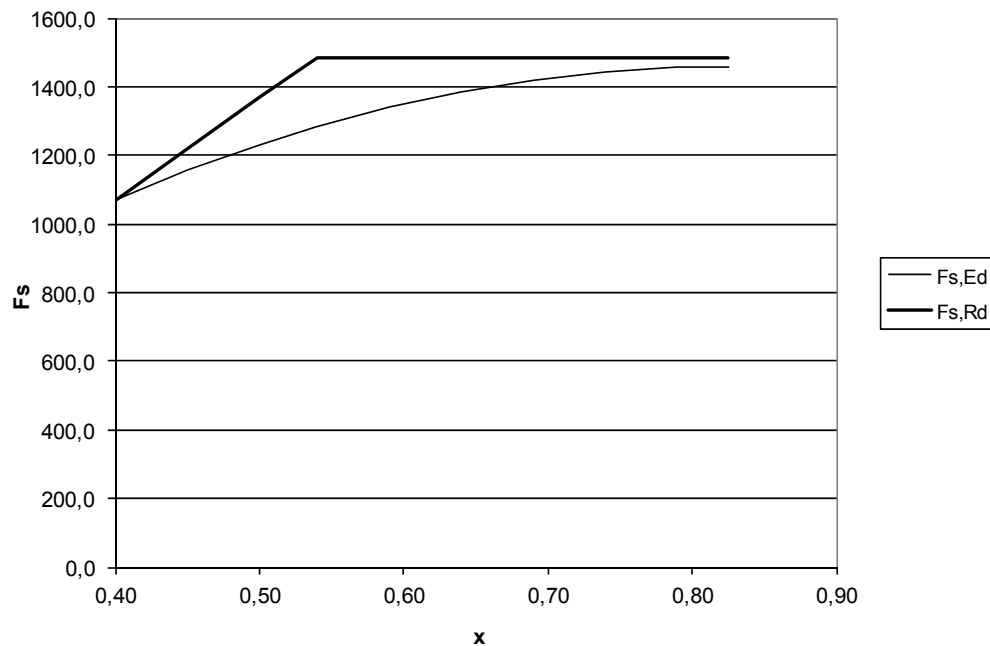

Fig.4.2.6 Forces in the reinforcement $\phi 16$

For bars with diameter $\phi = 20$ mm:

$$d = h - c_{nom} - 1,5\phi = 800 - 40 - 1,5 \cdot 20 = 730 \text{ mm}$$

$$z_i = 0,90d = 657 \text{ mm} \quad [9.8.2.2 (3)]$$

$$F_{s,max} = F_s(0,825) = 1469,0 \text{ kN} \Rightarrow$$

$$A_s = \frac{F_{s,max}}{f_{yk}/\gamma_s} = 33,79 \text{ cm}^2 \quad \Rightarrow 11\phi 20$$

In this case the clear distance between bars should be $162 \text{ mm} > s_{min} = 25 \text{ mm}$ (see Table 4.2.11).

For the straight anchorage of the bars, taking into account that for a $\phi=20\text{mm}$ bar $l_{bd} = 686 \text{ mm}$ (Table 4.2.2):

$$F_s(x_{min}) = F_s(0,40) = 1079,1 \text{ kN} \Rightarrow$$

$$l_b = \frac{F_s(x_{min})}{A_s f_{yd}} l_{bd} = \frac{1079,1}{1501,7} \cdot 686 = 493 \text{ mm}$$

$$l_b + c_{nom} = 533 \text{ mm} > x_{min} = 400 \text{ mm}$$

In this case a straight anchorage cannot be used, and a bend as in Figure 4.2.7, with $l_a = 195 \text{ mm}$ is needed.

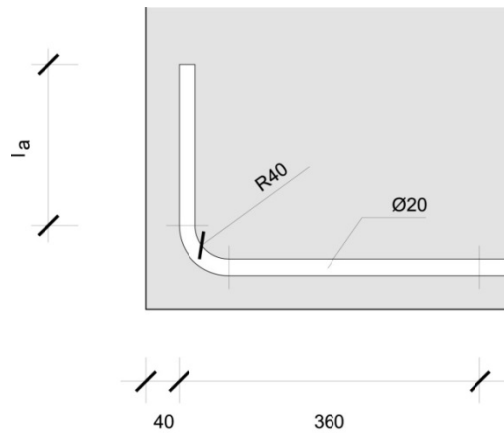

Fig.4.2.7 Bend anchorage for bars $\varnothing 20$

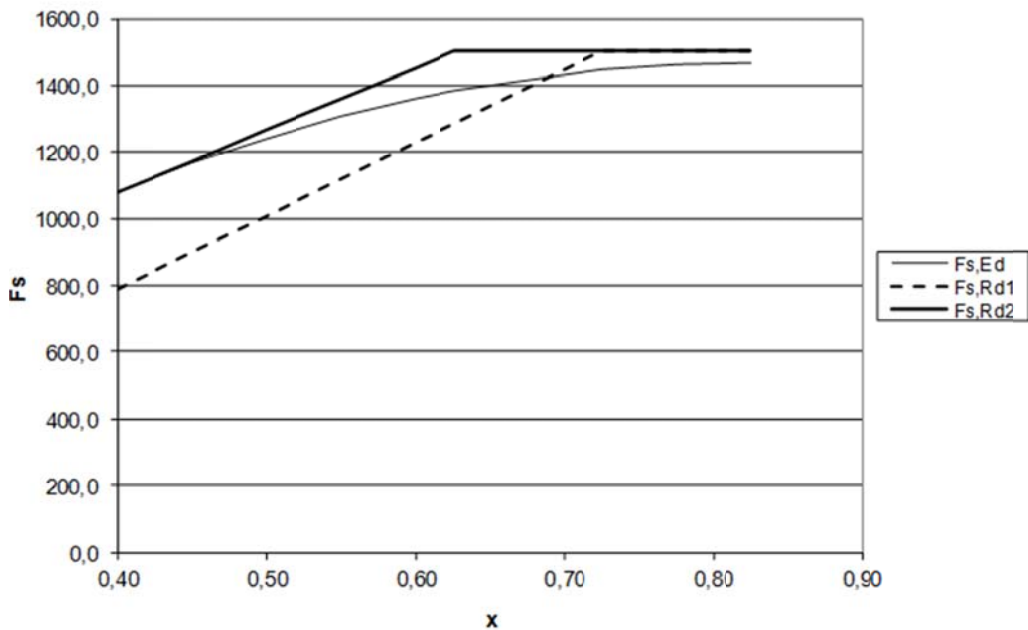

Fig.4.2.8 Forces in the reinforcement $\varnothing 20$

Figure 4.2.8 shows the actual force $F_{s,Ed}$ and the resistance forces $F_{s,Rd1}$ and $F_{s,Rd2}$ corresponding respectively to straight and bend anchorages.

For punching verification [6.4], in this specific case the basic control perimeter, which may be assumed at a distance $2,0d$ from the loaded area, is outside the footing.

4.2.2. Detailing of beams

Clause 9.2 contains the detailing rules for the beams. The material properties for the beams of the building are the following:

- Concrete: $f_{ck} = 25 \text{ N/mm}^2$; $\gamma_c = 1,50$; $f_{ctm} = 0,30f_{ck}^{2/3} = 2,56 \text{ N/mm}^2$
- Steel: $f_{yk} = 500 \text{ N/mm}^2$; $\gamma_s = 1,15$

The minimum area $A_{s,min}$ of longitudinal tension reinforcement [9.2.1.1 (1)] is:

$$A_{s,min} = 0,26 \frac{f_{ctm}}{f_{yk}} b_t d \not\leq 0,0013 b_t d \Rightarrow A_{s,min} = 0,00133 b_t d$$

b_t being the mean width of the tension zone.

The maximum area $A_{s,max}$ of longitudinal tension or compression reinforcement [9.2.1.1 (3)] is:

$$A_{s,max} = 0,04 A_c$$

For the curtailment of the longitudinal tension reinforcement the “shift rule” [9.2.1.3 (2)], gives the following shift length a_l :

$$a_l = z \frac{(\cot \theta - \cot \alpha)}{2}$$

Assuming $z = 0,9d$ and vertical links as shear reinforcement ($\alpha = 90^\circ$), the shift length is:

$$a_l = 0,45d \cot \theta$$

$\cot \theta$ has the same value as for the design of shear reinforcement.

For shear reinforcement, the minimum ratio is [9.2.2 (5)]:

$$\rho_{w,min} = \frac{A_{sw}}{s b_w \sin \alpha} = \frac{0,08 \sqrt{f_{ck}}}{f_{yk}} \Rightarrow \rho_{w,min} = 0,0008$$

As $\alpha = 90^\circ$

$$\left(\frac{A_{sw}}{s} \right)_{min} = 0,0008 b_w$$

The maximum longitudinal spacing between links $s_{l,max}$ is given by:

$$s_{l,max} = 0,75d (1 + \cot \alpha) = 0,75d$$

The maximum value for the transverse spacing of the legs of shear links $s_{t,max}$ is defined by:

$$s_{t,max} = 0,75d \not\geq 600 \text{ mm}$$

4.2.2.1 Beam A2 – B2 – C2 for the case 1

This beam corresponds to case 1: two way slab on beams. The geometry is defined in Figure 4.2.9:
Assuming $\phi_w = 8$ mm for links and $\phi = 16$ mm for longitudinal reinforcement, we obtain:

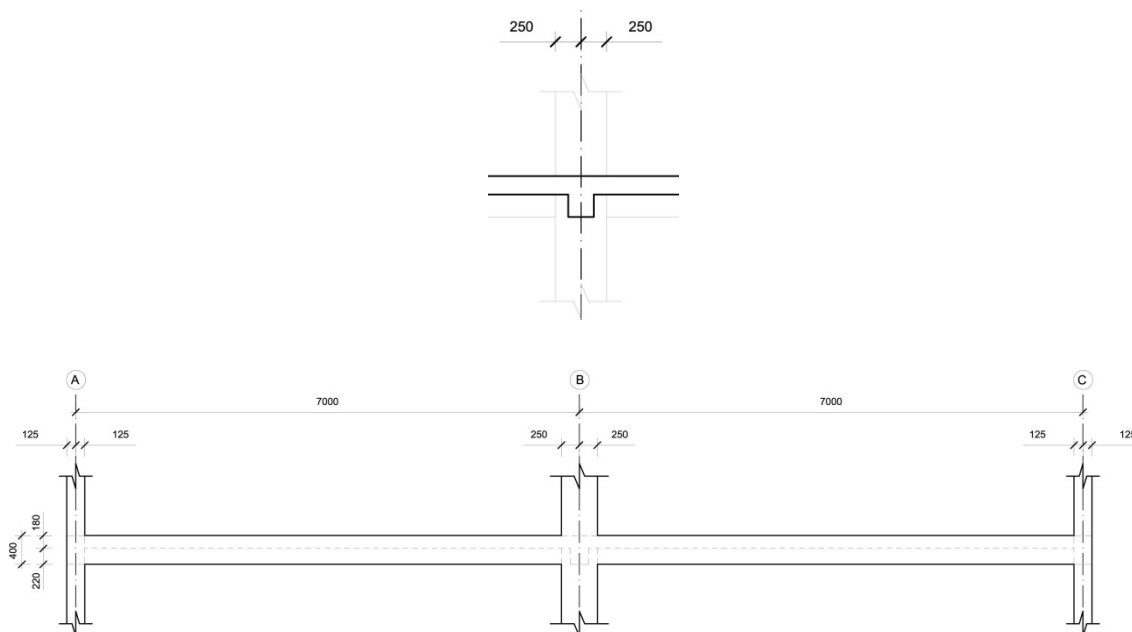

Fig.4.2.9 Geometric definition of beam A2 – B2 – C2

$$d = h - c_{nom} - \phi_w - \frac{\phi}{2} = 400 - 30 - 8 - 8 = 354 \text{ mm}$$

$$b_t = \begin{cases} 250 \text{ mm} & \text{for positive moments} \\ 1100 \text{ mm} & \text{for negative moments} \end{cases}$$

$$b_w = 250 \text{ mm}$$

Substituting these values in the previous expressions we obtain:

$$A_{s,min} = 0,00133b_t d = \begin{cases} 118 \text{ mm}^2 & \text{for positive moments} \\ 518 \text{ mm}^2 & \text{for negative moments} \end{cases}$$

$$A_{s,max} = 0,04A_c = 6520 \text{ mm}^2$$

$$a_l = 0,45d \cot \theta = 400 \text{ mm} \quad \text{for } \cot \theta = 2,5$$

$$\left(\frac{A_{sw}}{s} \right)_{min} = 0,0008b_w = 0,20 \frac{\text{mm}^2}{\text{mm}}$$

$$s_{l,max} = 0,75d = 266 \text{ mm}$$

$$s_{t,max} = 0,75d = 266 \text{ mm}$$

From calculations we obtain the envelope of the internal forces: positive and negative moments and shear, and then the envelope of the required longitudinal and transverse reinforcement forces. In Figure 4.2.10 we can see the envelope of the required force $F_{s,Ed}$ for the top and the bottom longitudinal reinforcement.

Due to inclined cracks these envelopes are shifted of length al obtaining $F_{s,Ed}^*$ that represents the capacity of the reinforcement required. For the selected number of longitudinal bars the resisted force $F_{s,Rd}$ taking into account the anchorage lengths are calculated and drawn. At any section it must be : $F_{s,Rd} \geq F_{s,Ed}^*$.

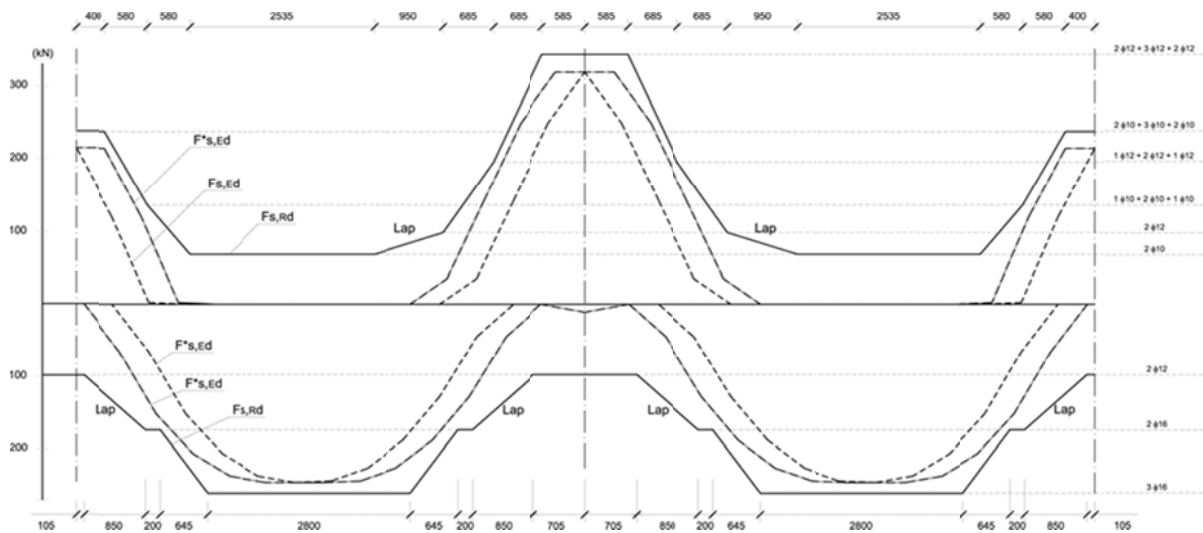

Fig.4.2.10 Curtailment of longitudinal reinforcement - Beam A2 – B2 – C2

For the shear reinforcement, we obtain the required force in the transverse reinforcement $F_{sw,Ed}$ from the envelope of the shear and we dispose links with a capacity of $F_{sw,Rd}$ so that: $F_{sw,Rd} \geq F_{sw,Ed}$. (Figure 4.2.11).

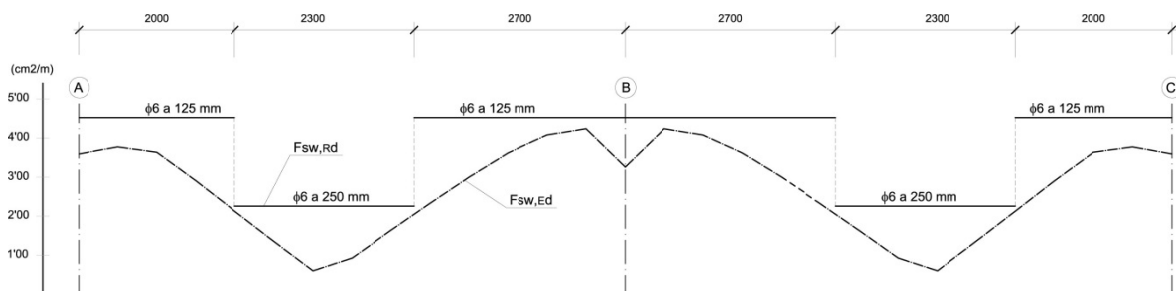

Fig.4.2.11 Transverse reinforcement envelope - Beam A2 – B2 – C2

Figure 4.2.12 shows the final arrangement of the longitudinal and the transverse reinforcement for this beam.

Detailing of reinforcement
J. Arrieta

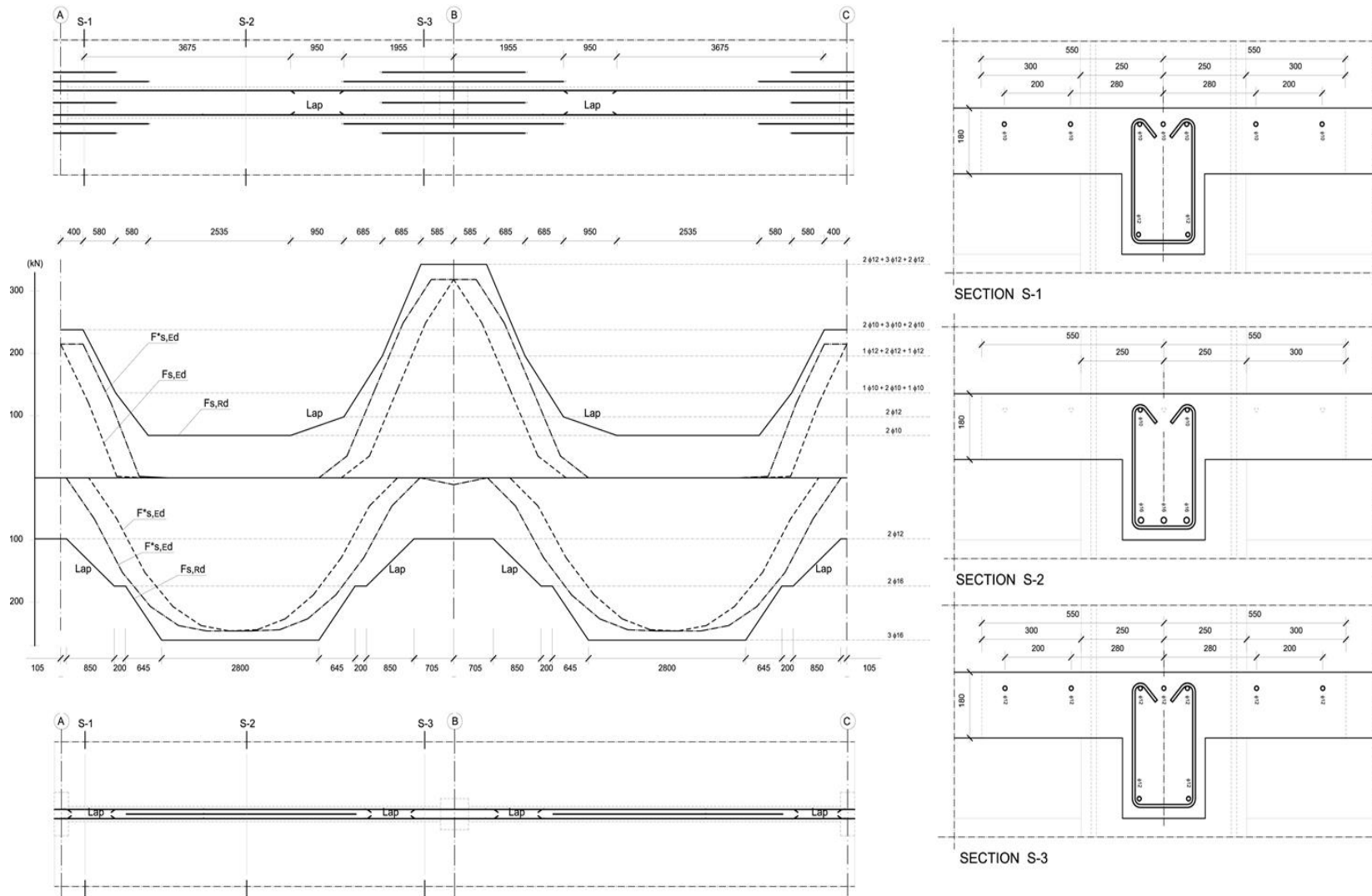

Fig.4.2.12 Reinforcement - Beam A2 – B2 – C2

4.2.2.2 Beam B1 – B2 – B3 for the case 3

This is the case of monodirectional slab with embedded lighting elements. The geometric dimensions of this beam are in Figure 4.2.13.

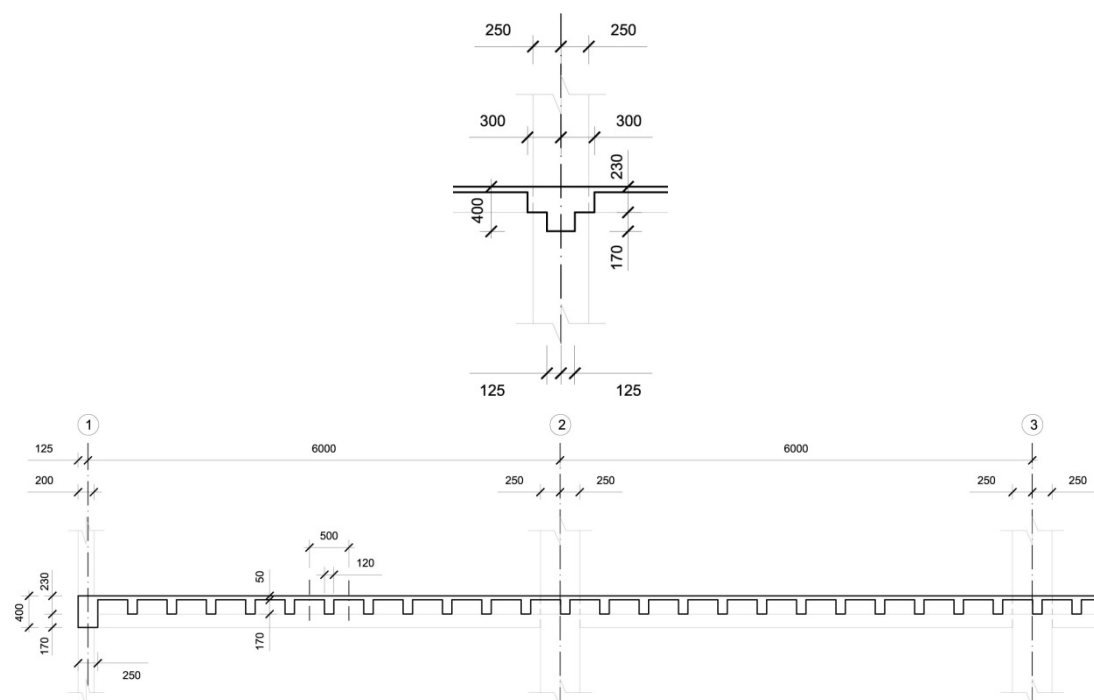

Fig.4.2.13 Geometric definition of beam B1 – B2 – B3

Assuming as in the previous case $\phi_w = 8$ mm for the links and $\phi = 16$ mm for the longitudinal reinforcement, we obtain:

$$d = h - c_{nom} - \phi_w - \frac{\phi}{2} = 400 - 30 - 8 - 8 = 354 \text{ mm}$$

$$b_t = \begin{cases} 250 \text{ mm} & \text{for positive moments} \\ 600 \text{ mm} & \text{for negative moments} \end{cases}$$

$$b_w = 250 \text{ mm}$$

$$A_{s,min} = 0,00133b_t d = \begin{cases} 118 \text{ mm}^2 & \text{for positive moments} \\ 282 \text{ mm}^2 & \text{for negative moments} \end{cases}$$

$$A_{s,max} = 0,04A_c = 722 \text{ mm}^2$$

$$a_i = 0,45d \cot \theta = 400 \text{ mm} \quad \text{for } \cot \theta = 2,5$$

$$\left(\frac{A_{sw}}{s} \right)_{min} = 0,0008b_w = 0,20 \frac{\text{mm}^2}{\text{mm}}$$

$$s_{l,max} = 0,75d = 266 \text{ mm}$$

$$s_{t,max} = 0,75d = 266 \text{ mm}$$

As for beam 2, we obtain the envelopes of the internal forces and the required reinforcement. Figure 4.2.14 shows the envelope of the required force $F_{s,Ed}$ for the top and the bottom longitudinal reinforcement, the shifted envelope $F'_{s,Ed}$ and the resisted force $F_{s,Rd}$. At any section $F_{s,Rd} \geq F'_{s,Ed}$.

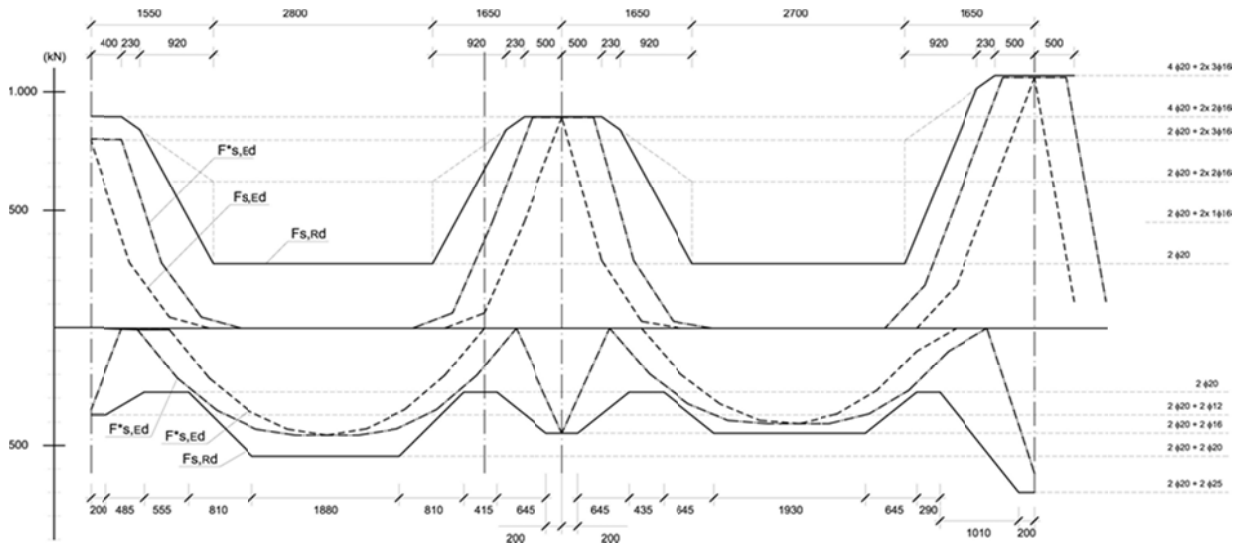

Fig.4.2.14 Curtailment of the longitudinal reinforcement of beam B1 – B2 – B3

For the shear reinforcement, we obtain the required force in the transverse reinforcement from the envelop of shear and we dispose links with a capacity of $F_{sw,Rd}$ so that: $F_{sw,Rd} \geq F_{sw,Ed}$ (Figure 4.2.15).

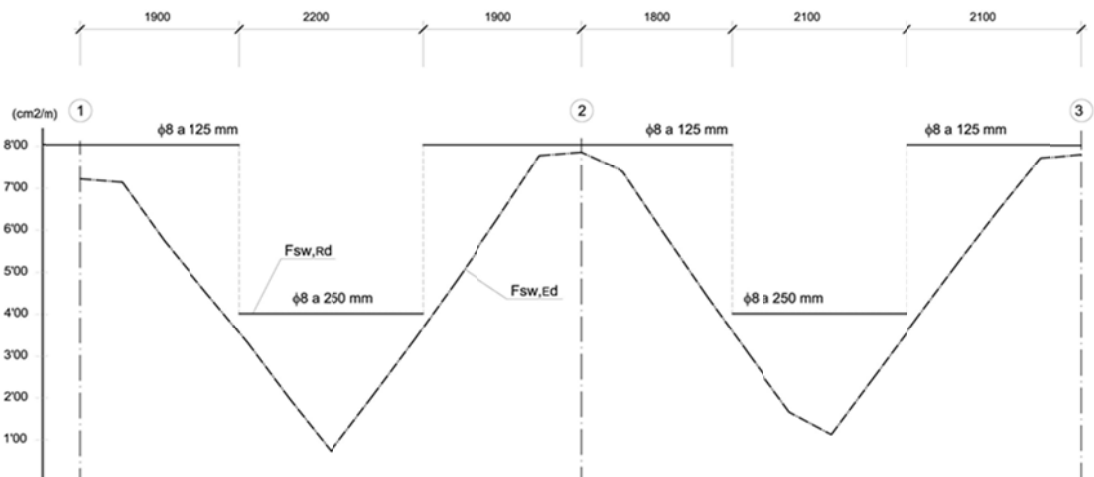

Fig.4.2.15 Transverse reinforcement envelop - Beam B1 – B2 – B3

In Figure 4.2.16 is the final arrangement of the longitudinal and the transverse reinforcement for this beam.

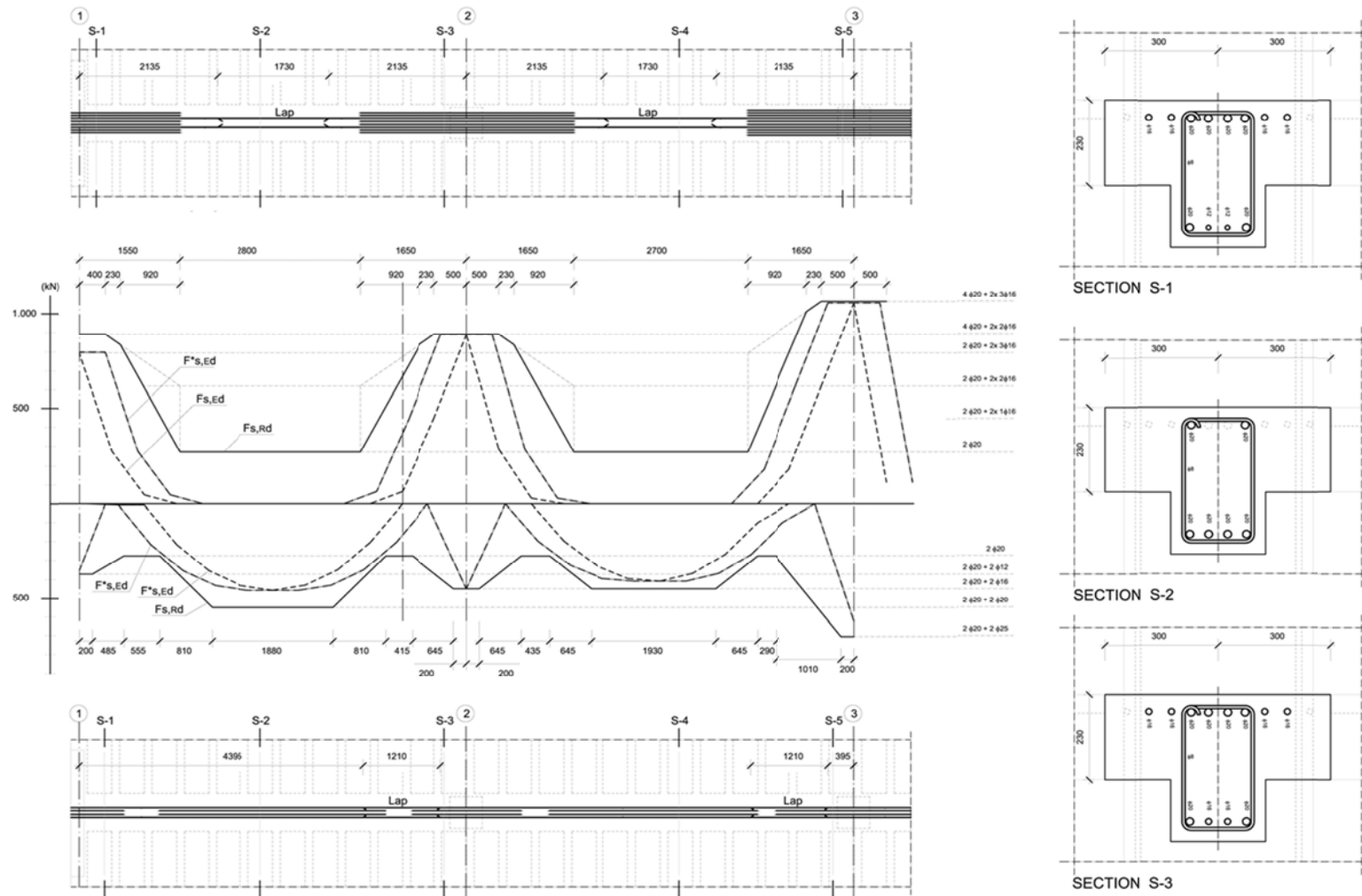

Fig.4.2.16 Reinforcement - Beam B1 – B2 – B3

4.2.3. Detailing of slabs

The material properties of slabs are the same as those of the beams.

4.2.3.1 Slab AB12 for case 1

In this case (two way slab on beams) the slab has a total height of 18 cm. In Figure 4.2.17 is shown the geometry of the slab.

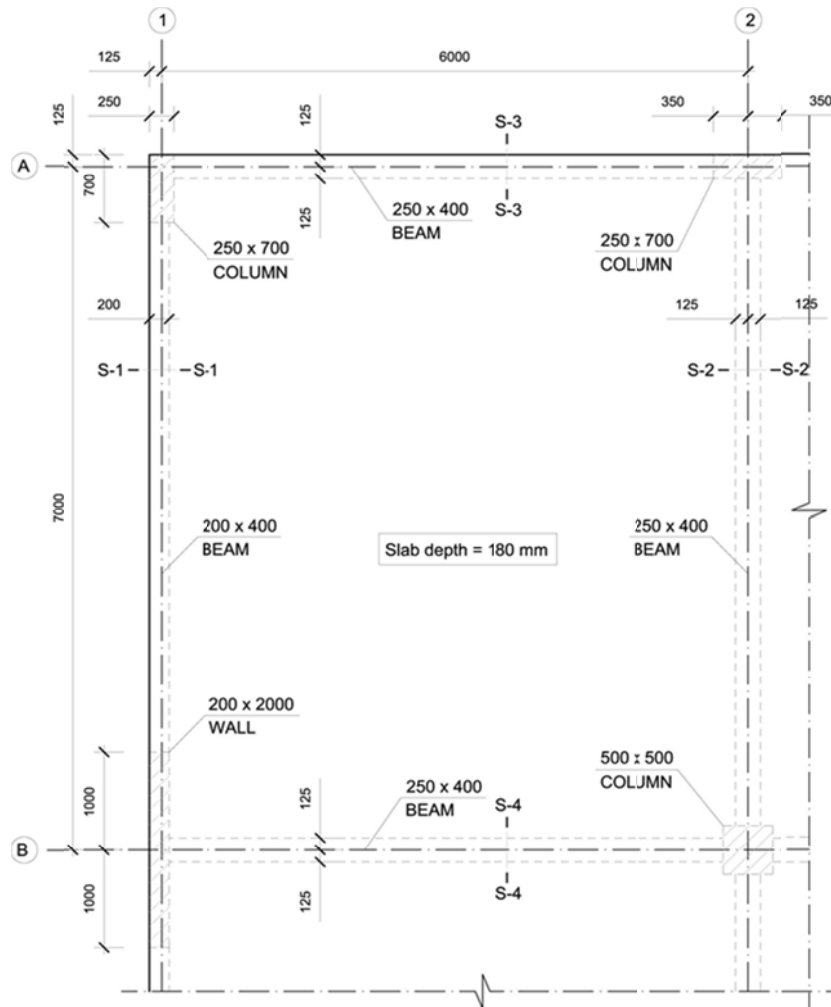

Fig.4.2.17 Geometric definition of slab AB12 for case 1

Provisions for the detailing of the reinforcement for this type of slabs are exposed in *Clause 9.3*. The minimum and maximum values for the reinforcement area, $A_{s,min}$ and $A_{s,max}$, are the same as for the beams [9.3.1.1 (1)]. For a slab unit width ($b = 1 \text{ mm}$):

$$d = h - c_{nom} - \phi - \frac{\phi}{2} = 180 - 30 - 12 - 6 = 132 \text{ mm} \quad (\phi = 12 \text{ mm})$$

$$b_t = 1 \text{ mm}$$

$$A_{s,\min} = 0,00133b_t d = 0,176 \frac{\text{mm}^2}{\text{mm}}$$

$$A_{s,\max} = 0,04A_c = 7,200 \frac{\text{mm}^2}{\text{mm}}$$

The maximum spacing of the bars $s_{\max,slabs}$ is [9.3.1.1 (3)]:

$$s_{\max,slabs} = 2,0 \cdot h \not> 250 \text{ mm} \Rightarrow s_{\max,slabs} = 250 \text{ mm}$$

And the shift length for the curtailment of the reinforcement [9.3.1.1 (4)] is:

$$a_t = d = 132 \text{ mm}$$

The design of the slab gives the required reinforcement in each (X,Y) direction, for each strip (Figure 4.2.18).

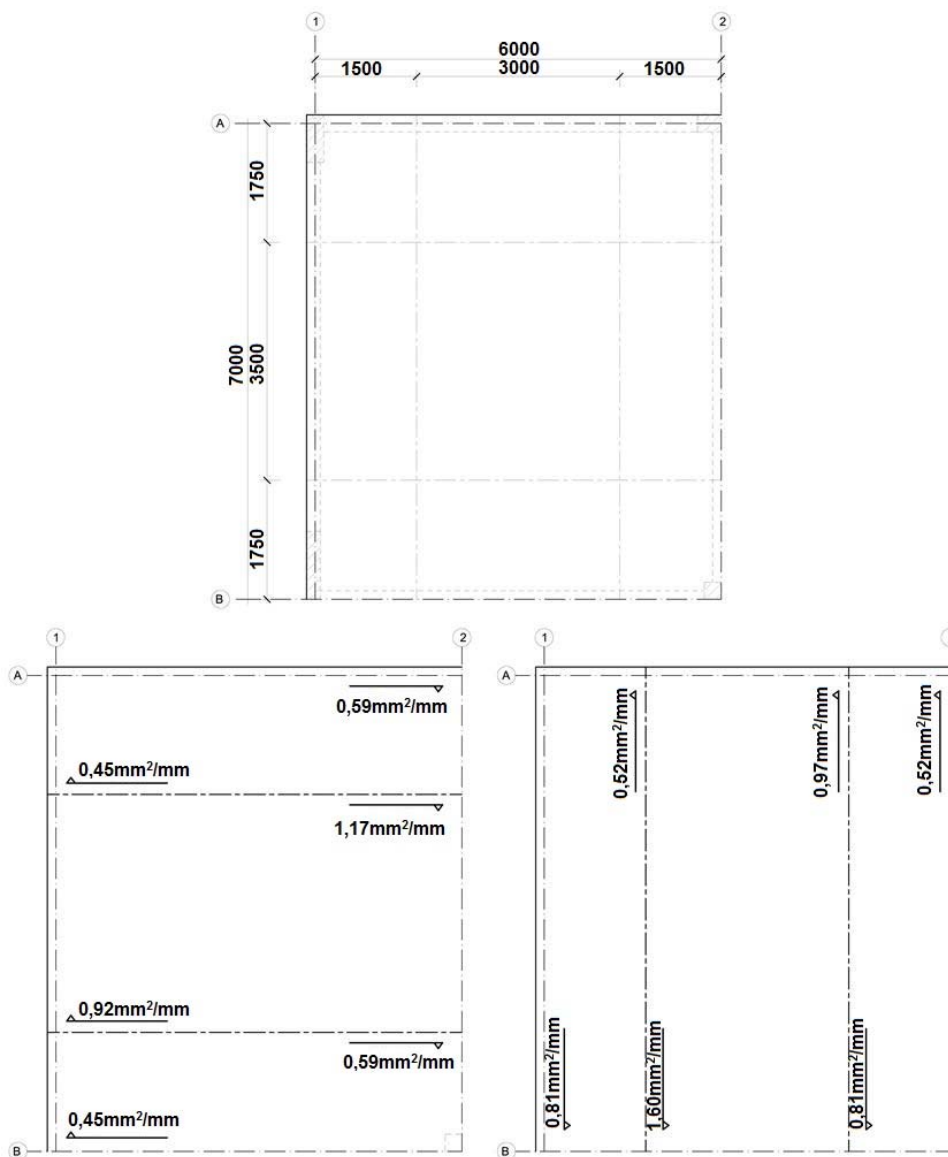

Fig.4.2.18 Required reinforcement of slab AB12 for case 1

Finally we dispose the real reinforcement, taking into account the previous provisions about limit values for areas, diameters and distances (Figure 4.2.19).

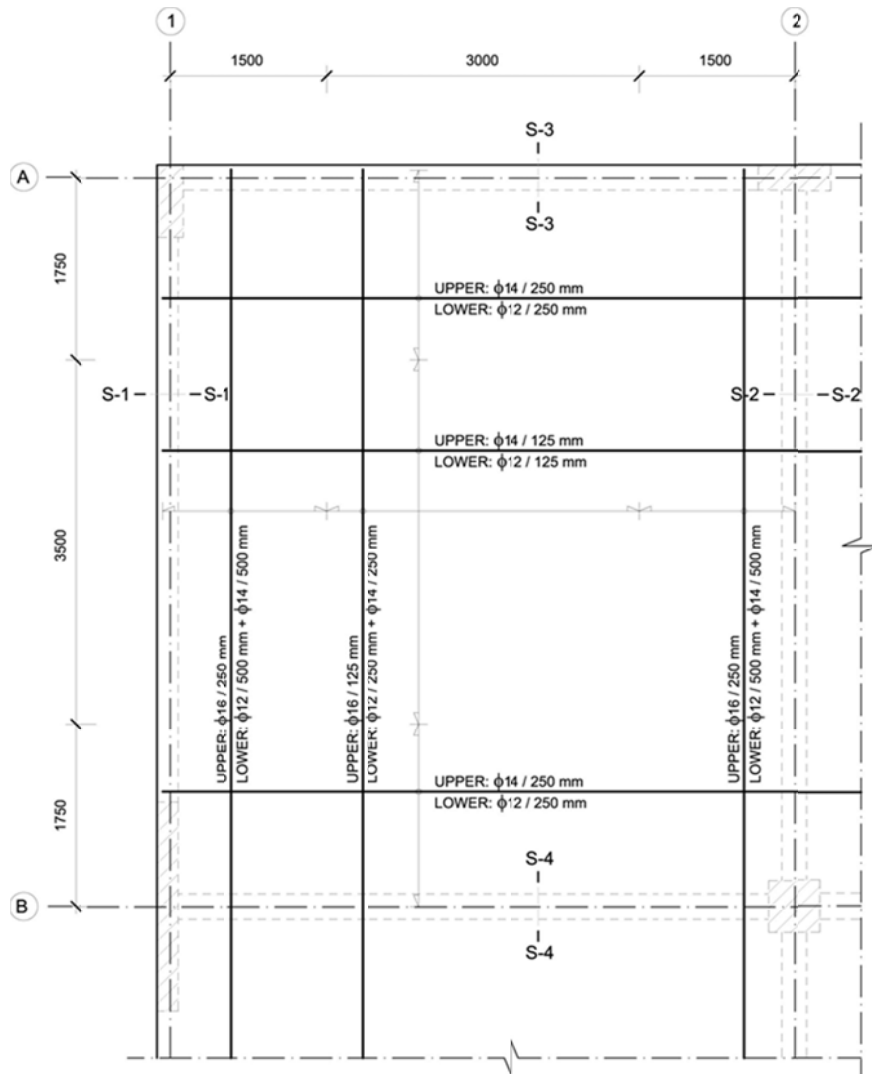

Fig.4.2.19 Arrangement of reinforcement of slab AB12 for case 1

4.2.4. Detailing of columns

The characteristics of a column, as a structural member, are defined in §5.3.1 and the detailing rules are in section 9.5.

For the longitudinal reinforcement (9.5.2), the minimum diameter of the bars is $\phi_{min}=8$ mm and the total amount of its area is limited by a minimum and a maximum value:

$$A_{s,min} = \max \left[\frac{0,10N_{Ed}}{f_{yd}}; 0,002Ac \right]$$

$$A_{s,max} = 0,04A_c$$

where A_c is the sectional area of the column.

For transverse reinforcement (9.5.3) the minimum diameter $\phi_{t,min}$ is defined and the maximum spacing $s_{t,max}$ are :

$$\phi_{t,min} = \max \left[6 \text{ mm} ; \frac{1}{4} \phi_{long} \right]$$

$$s_{t,max} = \min [20\phi_{long}; b_{min}; 400 \text{ mm}]$$

This maximum spacing is reduced by a factor 0,60, in zones near a beam or a slab, and in lapped joints if the diameter of the bars is greater than 14 mm. In this case, a minimum of 3 bars must be present.

No longitudinal compression bar can be at a clear distance greater than 150 mm from a restrained bar; restraining is done through transverse reinforcement or splices.

When there is a change of direction in a longitudinal bar, the lateral forces may be ignored if the slope of the change is less or equal to 1 in 12, otherwise pushing forces have to be considered.

4.2.4.1 Column B2 for the case 2

The column analysed corresponds to case 2: flat solid slab. The geometrical data are in Figure 4.2.20.

The materials used to make the columns have the following properties:

- Concrete: $f_{ck} = 30 \text{ N/mm}^2$; $\gamma_c = 1,50$; $f_{ctm} = 0,30f_{ck}^{2/3} = 2,90 \text{ N/mm}^2$
- Steel: $f_{yk} = 500 \text{ N/mm}^2$; $\gamma_s = 1,15$

Applying the actual values of the column to the previous expressions we obtain:

- Longitudinal reinforcement

$$\phi_{min} = 8 \text{ mm}$$

$$A_{s,min} = \max [0,23N_{Ed}; 500 \text{ mm}^2]$$

$$A_{s,max} = 10000 \text{ mm}^2$$

- Transverse reinforcement

$$\phi_{t,min} = \begin{cases} 6 \text{ mm} & \text{if } \phi_{long} \leq 24 \text{ mm} \\ \frac{\phi_{long}}{4} & \text{if } \phi_{long} > 24 \text{ mm} \end{cases}$$

$$s_{t,max} = \min [20\phi_{long}; 400 \text{ mm}]$$

The characteristics of a column, as a structural member, are defined in Cause 5.3.1 and the detailing rules in Section 9.5.

For the longitudinal reinforcement (9.5.2), the bar's minimum diameter is $\phi_{min}=8$ mm and the total amount is limited by a minimum and a maximum value:

$$A_{s,min} = \max \left[\frac{0,10 \cdot N_{Ed}}{f_{yd}}; 0,002Ac \right]$$

$$A_{s,max} = 0,04A_c$$

where A_c is the transverse area of the column.

For transverse reinforcement (9.5.3) the minimum diameter $\phi_{t,min}$ and the maximum spacing $s_{t,max}$ are:

$$\phi_{t,min} = \max \left[6 \text{ mm}; \frac{1}{4} \phi_{long} \right]$$

$$s_{t,max} = \min [20\phi_{long}; b_{min}; 400 \text{ mm}]$$

The maximum spacing is reduced by a factor 0,60 in zones near a beam or a slab, and in lapped joints if the diameter of bars is greater than 14 mm. In this case a minimum of 3 bars must be present.

No longitudinal compression bar can be at a clear distance greater than 150 mm from a restrained bar; restraining is obtained using transverse reinforcement or splices

When there is a change of direction in a longitudinal bar, the lateral forces may be ignored if the slope of the change is less or equal to 1:12, otherwise pushing forces have to be considered.

4.2.4.2 Column B2 - case 2

The column considered corresponds to case 2 - flat solid slab. Geometrical data are in figure 20.

The materials used have the following properties:

- Concrete: $f_{ck} = 30 \text{ N/mm}^2$; $\gamma_c = 1,50$; $f_{ctm} = 0,30f_{ck}^{2/3} = 2,90 \text{ N/mm}^2$
- Steel: $f_{yk} = 500 \text{ N/mm}^2$; $\gamma_s = 1,15$

Applying the actual values of the column to the previous expressions we obtain:

- Longitudinal reinforcement

$$\phi_{min} = 8 \text{ mm}$$

$$A_{s,min} = \max [0,23N_{Ed}; 500 \text{ mm}^2]$$

$$A_{s,max} = 10000 \text{ mm}^2$$

- Transverse reinforcement

$$\phi_{t,min} = \begin{cases} 6 \text{ mm} & \text{if } \phi_{long} \leq 24 \text{ mm} \\ \frac{\phi_{long}}{4} & \text{if } \phi_{long} > 24 \text{ mm} \end{cases}$$

$$s_{t,max} = \min [20\phi_{long}; 400 \text{ mm}]$$

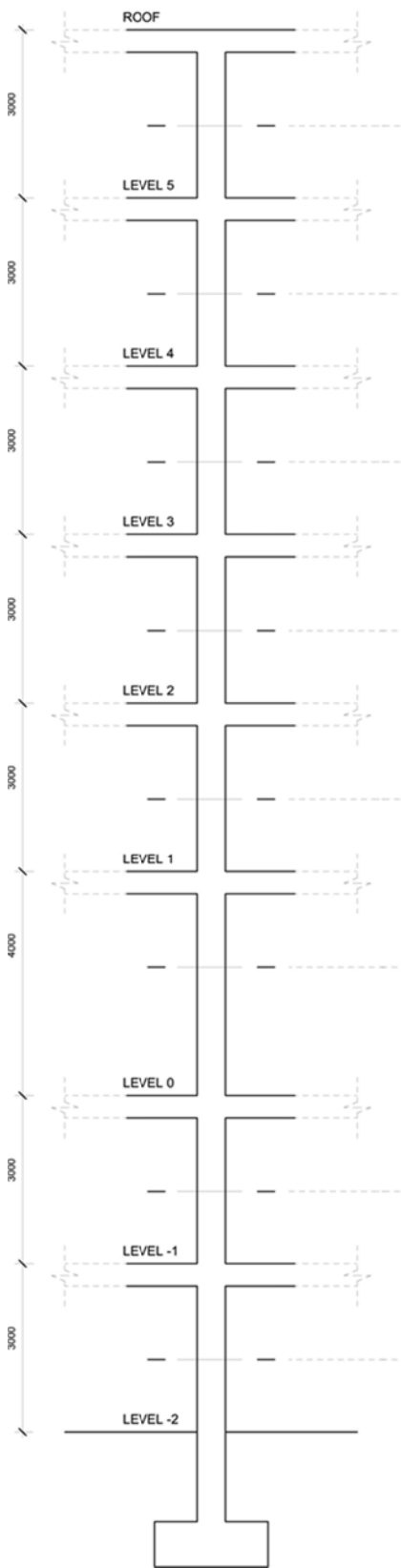

Fig.4.2.20 Geometric definition
column B2 – Case 2

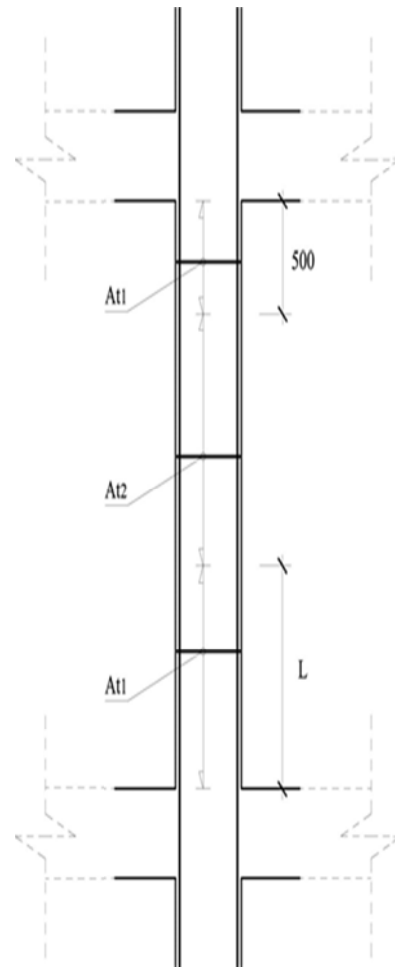

Fig.4.2.21 Transverse reinforcement
column B2 - Case 2

An uniform distributed reinforcement is provided along the perimeter of the column. If the total area of reinforcement required is $A_{s,rqd}$, applying the mentioned rules, the area of reinforcement really disposed is $A_{s,dsp}$ (Table 4.2.11).

Table 4.2.11 Longitudinal reinforcement for Column B2 – Case 2

Floor	$A_{s,rqd}$ [mm ²]	$A_{s,min1}$ [mm ²]	$A_{s,min2}$ [mm ²]	$A_{s,dsp}$ [mm ²]	
L-2/L-1	5581	1305	500	5892	12φ25
L-1/L0	3551	1177	500	3768	12φ20
L0/L1	1082	1012	500	1232	8φ14
L1/L2	0	838	500	904	8φ12
L2/L3	0	670	500	904	8φ12
L3/L4	0	504	500	628	8φ10
L4/L5	0	344	500	628	8φ10
L5/Roof	0	216	500	628	8φ10

Closed links are used for transverse reinforcement as in Figure 4.2.21. Following the prescriptions of the code the links spacing of the links is reduced in the zones close to the slab and in the laps.

Table 4.2.12 shows the extension of the zones and the links' diameter and spacing in each zone.

Table 4.2.12 Transverse reinforcement for column B2 – Case 2

Floor	$\phi_{t,min}$ [mm]	$s_{t,max}$ [mm]	L [mm]	Links	
				A_{t1}	A_{t2}
L-2/L-1	8	400	1340	φ8 - 240	φ8 - 400
L-1/L0	6	400	1340	φ6 - 240	φ6 - 400
L0/L1	6	280	1072	2φ6 - 160	2φ6 - 280
L1/L2	6	240	751	2φ6 - 140	2φ6 - 240
L2/L3	6	240	643	2φ6 - 140	2φ6 - 240
L3/L4	6	200	643	2φ6 - 120	2φ6 - 200
L4/L5	6	200	536	2φ6 - 120	2φ6 - 200
L5/Roof	6	200	536	2φ6 - 120	2φ6 - 200

Finally in Figure 4.2.22 the arrangement of the column reinforcement is represented.

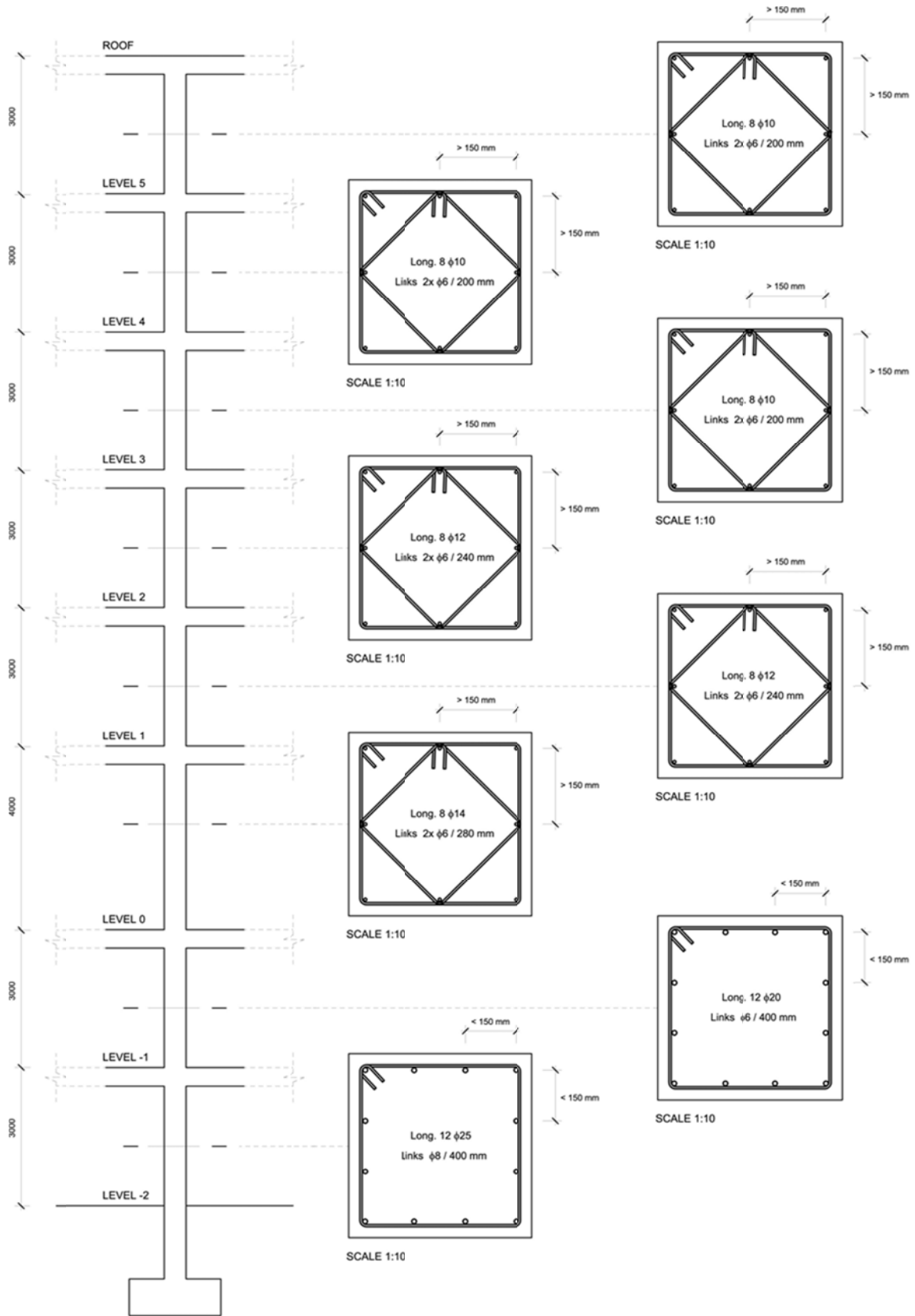

Fig.4.2.22 Reinforcement for column B2 - Case 2

CHAPTER 5

SOME GEOTECHNICAL ASPECTS OF BUILDING DESIGN (EN 1997)

Roger FRANK

*Université Paris-Est, Ecole des Ponts ParisTech, Laboratoire Navier
Geotechnical team (CERMES), France*

5.1 Introduction

Eurocode 7 deals with all the geotechnical aspects of the design of structures (buildings, bridges and civil engineering works) and should be used for all the problems of interaction of structures with the ground (soils and rocks), through foundations or retaining structures

Eurocode 7 allows the calculation of the geotechnical actions on the structures, as well the resistances of the ground submitted to the actions from the structures. It also gives all the prescriptions and rules for good practice required for properly conducting the geotechnical aspects of a structural project or, more generally speaking, a purely geotechnical project.

Eurocode 7 consists of two parts:

- *EN 1997-1 Geotechnical design - Part 1: General rules (CEN, 2004)*
- *EN 1997-2 Geotechnical design - Part 2: Ground investigation and testing (CEN, 2007).*

In the following, it is applied to the geotechnical design of a reinforced concrete building, designed by applying the principles of *Eurocode 2*.

The example building is a six-storey building, with two storeys below the ground level. It is designed as a reinforced concrete skeleton construction and has total dimensions of 30,25 m in length, 14,25 m in width and a height of 19 m above ground level – details are in Chapter 1.

The inner columns are founded on square spread foundations of dimensions $B = 2$ m and $L = 2$ m; the outer columns and the shear walls are supported by a peripheral diaphragm retaining wall of width 0,6 m, of height 9 m (embedded 3 m below the 2 levels of parking) – see Figure 5.2.1.

After some considerations about the geotechnical data, the following calculations will be presented:

- for column B2: bearing capacity and sliding resistance of the spread foundations (ULS verifications);
- comments on the settlement of the columns (SLS verification).

5.2 Geotechnical data

The soil investigation can consist of core sampling, laboratory tests (e.g. identification and tri-axial compression tests), field tests (e.g. pressuremeter tests MPM and cone penetration CPT tests), etc. - see *EN 1997-2 (CEN, 2007)* for the use of these tests in geotechnical design). The selection of appropriate values of soil properties for foundations (or other geotechnical structures) is probably the most difficult and challenging phase of the whole geotechnical design process and cannot be extensively described here.

In the *Eurocodes* approach, in particular the *Eurocode 7* one, characteristic values of materials properties should be determined before applying any partial factor of safety. Figure 5.2.2 shows the link between the two parts of *Eurocode 7* and, more important, gives the path leading to characteristic values.

The present 'philosophy' with regard to the definition of characteristic values of geotechnical parameters is contained in the following clauses of *Eurocode 7 – Part 1 (clause 2.4.5.2 in EN1997-1)*:

'(2)P The characteristic value of a geotechnical parameter shall be selected as a cautious estimate of the value affecting the occurrence of the limit state.'

'(7) [...]the governing parameter is often the mean of a range of values covering a large surface or volume of the ground. The characteristic value should be a cautious estimate of this mean value.'

These paragraphs in *Eurocode 7 – Part 1* reflect the concern that one should be able to keep using the values of the geotechnical parameters that were traditionally used (the determination of which is not standardised, i.e. they often depend on the individual judgment of the geotechnical engineer,). However two remarks should be made at this point.

- on the one hand, the concept of 'derived value' of a geotechnical parameter (preceding the determination of the characteristic value) has been introduced (see Fig.5.2.1);
- on the other hand, there is now a clear reference to the limit state involved (which may look evident, but is, in any case, a way of linking traditional geotechnical engineering and the new limit state approach) and to the assessment of the mean value (and not to a local value; this might appear to be a specific feature of geotechnical design which, indeed, involves 'large' areas or 'large' ground masses).

Statistical methods are mentioned only as a possibility:

'(10) If statistical methods are employed [...], such methods should differentiate between local and regional sampling [...].'

'(11) If statistical methods are used, the characteristic value should be derived such that the calculated probability of a worse value governing the occurrence of the limit state under consideration is not greater than 5%.

NOTE In this respect, a cautious estimate of the mean value is a selection of the mean value of the limited set of geotechnical parameter values, with a confidence level of 95%; where local failure is concerned, a cautious estimate of the low value is a 5% fractile.'

For the sake of simplicity, in the present study, it is assumed that the whole building is founded on a very stiff clay with the following characteristics:

- undrained shear strength (in terms of total stresses): $c_u = 300$ kPa
- total unit weight $\gamma_k = 20$ kN/m³

The water-table is assumed to be at natural ground level.

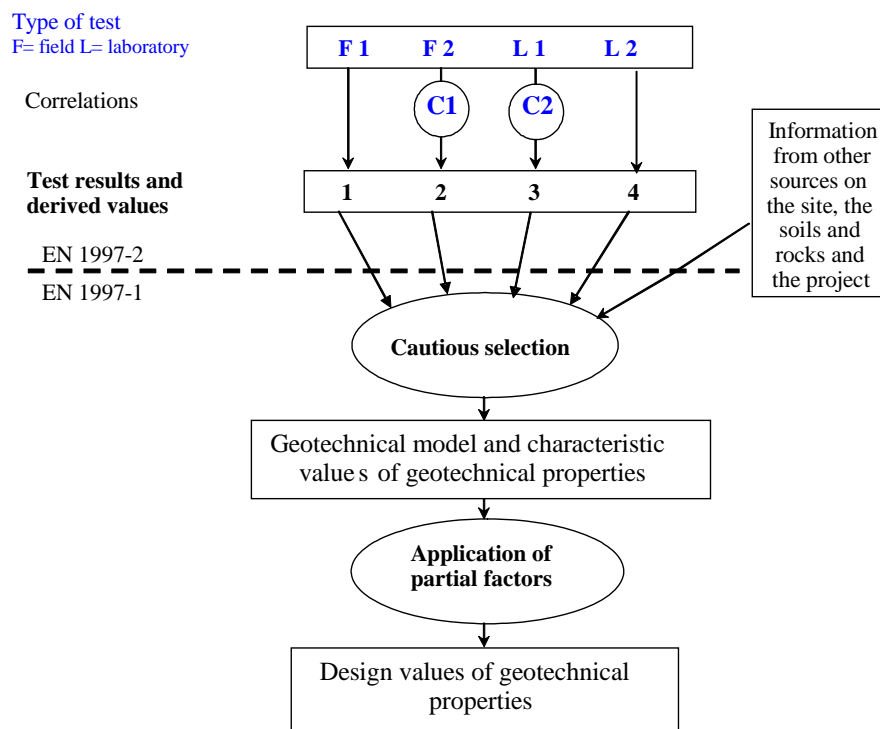

Fig.5.2.1 General framework for the selection of derived values, characteristic values and design values of geotechnical properties (CEN, 2007)

5.3 Actions on the foundations

5.3.1. Structural and geotechnical actions

The 'structural' actions to be considered on the foundations are taken from the structural analysis in Chapter 2. The combinations of forces and moments for column B2 are given at the sole of the foundation (0,8 m thick) both at ULS (for permanent and transient design situations, i.e. fundamental combinations) and at SLS – see Tables 5.3.1. For the diaphragm retaining wall, active and passive pressures from the ground and the groundwater (geotechnical actions) must also be considered.

Table 5.3.1. Forces and moments on the foundation of column B2 - ULS and SLS

Column B2

Situation Foundation
Position of internal forces at the sole of the Foundation

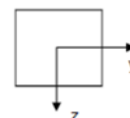

Ultimate limit state

Superposition	N [kN]	V _y [kN]	V _z [kN]	M _y [kNm]	M _z [kNm]	Considered load cases
Combination:	1,35 * G + 1,5 * Q1 + 1,5 * Σ(psi0 * Qi)					Q1 Qi
max M _y , accordingly N, V und M _z	-4625,82	0,23	-4,05	4,21	-0,31	101 203 - 206, 1356, 10111
max M _z , acc. N, V und M _y	-4935,82	4,46	1,88	-2,43	4,45	10111 51, 203- 206, 10011
max V _y , acc. M, N und V _z	-4935,82	4,46	1,88	-2,43	4,45	10111 51, 203- 206, 10011
max V _z , acc. M, N und V _y	-5247,33	-2,46	2,96	-3,62	-2,08	51 10031, 10101
max N, acc. V und M	-4516,94	-1,83	2,27	-2,73	-1,38	51 202-205
min M _y , acc. N, V und M _z	-5408,62	-2,48	2,96	-3,64	-2,12	51 201, 1326, 10031, 10101
min M _z , acc. N, V und M _y	-5515,83	-4,65	-1,43	1,17	-4,85	10121 101, 201, 202, 1326, 10021
min V _y , acc. M, N und V _z	-5466,27	-4,81	1,46	-2,09	-4,70	10121 201, 202, 1356, 10021
min V _z , acc. M, N und V _y	-4575,29	0,25	-4,05	4,20	-0,29	101 202-206, 10111
min N, acc. V und M	-5805,49	-4,53	1,54	-2,36	-4,49	10031+1336 201, 10121

Serviceability limit state

Superposition	N [kN]	Vy [kN]	Vz [kN]	My [kNm]	Mz [kNm]	Considered load cases	
Characteristic combination							
Combination	1,00 * G + 1,00 * Q1 + 1,00 * Σ(psi0 * Qi)					Qi	
max My, accordingly N, V und Mz	-3419,34	-0,10	-263	2,70	-0,45	101	203 - 206, 1356, 10111
max Mz, acc. N, V und My	-3626,00	2,72	131	-1,73	2,72	10111	51, 203- 206, 10011
max Vy, acc. M, N und Vz	-3626,00	2,72	131	-1,73	2,72	10111	51, 203- 206, 10011
max Vz, acc. M, N und Vy	-3833,68	-1,89	204	-2,52	-1,63	51	10031, 10101
max N, acc. V und M	-3346,75	-1,47	158	-1,93	-1,17	51	202-205
min My, acc. N, V und Mz	-3941,20	-1,91	204	-2,53	-1,66	51	201, 1326, 10031, 10101
min Mz, acc. N, V und My	-4012,68	-3,35	-0,89	0,67	-3,48	10121	101, 201, 202, 1326, 10021
min Vy, acc. M, N und Vz	-3979,64	-3,46	104	-1,50	-3,38	10121	201, 202, 1356, 10021
min Vz, acc. M, N und Vy	-3385,65	-0,08	-263	2,69	-0,44	101	202-206, 10111
min N, acc. V und M	-4205,78	-3,27	109	-1,68	-3,23	10031-1336	201, 10121

Virtually-permanent combination

Combination	1,00 * G + 1,00 * Σ(psi2 * Qi)					Considered load cases	
						Qi	
max My, accordingly N, V und Mz	-3396,43	-0,60	063	-1,04	-0,60	1356, 10111	
max Mz, acc. N, V und My	-3499,06	1,28	068	-1,11	1,18	10011, 10111	
max Vy, acc. M, N und Vz	-3499,06	1,28	068	-1,11	1,18	10011, 10111	
max Vz, acc. M, N und Vy	-3562,90	-2,71	082	-1,31	-2,64	10031, 10101	
max N, acc. V und M	-	-	-	-	-	not applicable	
min My, acc. N, V und Mz	-3606,55	-2,83	092	-1,39	-2,73	1326, 10031, 10101	
min Mz, acc. N, V und My	-3676,67	-3,32	095	-1,35	-3,16	1326, 10021, 10121	

5.3.2. General: the three design approaches of Eurocode 7

When checking STR/GEO Ultimate Limit States for permanent and transient design situations (fundamental combinations), 3 Design Approaches (DA) are offered by *Eurocode EN 1990* and *Eurocode EN 1997-1 (Eurocode 7 – Part 1; CEN, 2004)*. The choice, for each geotechnical structure, is left to the National Application Document.

For the bearing capacity of spread foundations and for retaining structures, these approaches can be summarised as follows.

5.3.2.1 Design approach 1 (DA1)

Two combinations (DA1-1 and DA1-2) should be used. It should be checked that an ULS is not reached for either of the two combinations.

Combination 1 (DA1-1) is called the 'structural combination' because safety is applied on actions (i.e. partial load factors $\gamma_F \geq 1,0$ are applied to action effects) while the design value of the geotechnical resistance R_d is based on the materials characteristic resistance.

With the recommended values given in *Note 2 of Table A2.4 (B) of EN 1990, for Eqn.6.10*:

$$E_d \{ \gamma_F F_{rep} \} \leq R_d \{ X_k \} \quad (5.1)$$

where γ_F means $\gamma_{G,sup} = 1,35$; $\gamma_{G,inf} = 1,00$; $\gamma_{G,set} = 1,35$; 1,20 or 0; and $\gamma_Q = 1,20$ to 1,50 or 0.

Combination 2 (DA1-2) is called the 'geotechnical combination' because the safety is applied on the geotechnical resistance R_d , through partial material factors $\gamma_M > 1,0$, applied at the 'source' to the ground parameters themselves. No safety factor is applied on unfavourable permanent ('structural' or 'geotechnical') actions. Note that for the resistance of piles and anchors resistances factors γ_R are used instead of material factors γ_M .

With the recommended values given in the *Note of Table A2.4 (C) of EN 1990 for Eqn.6.10*:

$$E_d \{ \gamma_F F_{rep} \} \leq R_d \{ X_k / \gamma_M \} \quad (5.2)$$

where γ_F means $\gamma_{G,sup} = 1,00$; $\gamma_{G,inf} = 1,00$; $\gamma_{G,set} = 1,00$ or 0 ; and $\gamma_Q = 1,15$ to $1,30$ or 0 .

Table 5.3.3 summarises the recommended values of load factors used for DA1-1 (set A1) and DA1-2 (set A2).

Table 5.3.3 Partial factors on actions (γ_F) or the effects of actions (γ_E) (Table A.3 in EN 1997-1)

Action		Symbol	Set	
			A1	A2
Permanent	Unfavourable	γ_G	1,35	1,0
	Favourable		1,0	1,0
Variable	Unfavourable	γ_Q	1,5	1,3
	Favourable		0	0

For DA1-2, the recommended values for the partial factors γ_M both for 'geotechnical' actions and resistances are those of set M2 given in Table 5.3.4 (except for resistances of piles and anchors).

Table 5.3.4 Partial factors for soil parameters (γ_M) (Table A.4 in EN 1997-1)

Soil parameter	Symbol	Set	
		M1	M2
Angle of shearing resistance*	$\gamma_{\varphi'}$	1,0	1,25
Effective cohesion	$\gamma_{c'}$	1,0	1,25
Undrained shear strength	γ_{cu}	1,0	1,4
Unconfined strength	γ_{qu}	1,0	1,4
Weight density	γ_Y	1,0	1,0

* This factor is applied to $\tan \varphi'$

5.3.2.2 Design approach 2 (DA2 and DA2*)

Only one combination should be used to check that the ULS is not reached. Safety is applied on both actions and resistances. On the action side, the factors can be applied either on the actions themselves (DA2, factors γ_F) or on the actions' effects (DA2*, factors γ_E). Thus,

- o for DA2:

$$E_d \{ \gamma_F F_{rep} \} \leq R_d \{ Xk \} / \gamma_R \quad (5.3)$$

- o for DA2*:

$$\gamma_E E_d \{ F_{rep} \} \leq R_d \{ Xk \} / \gamma_R \quad (5.4)$$

The recommended values for γ_F or γ_E are given in Note 2 of Table A2.4 (B) of EN 1990, for Eqn. 6.10:

$$\gamma_{G,sup} = 1,35; \gamma_{G,inf} = 1,00; \gamma_{G,set} = 1,35; 1,20 \text{ or } 0; \text{ and } \gamma_Q = 1,20 \text{ to } 1,50 \text{ or } 0$$

The recommended values of the resistance factors for spread foundations and retaining structures are those for set R2 given in Table 5.3.5 and 5.3.6, respectively.

Table 5.3.5 Partial resistance factors (γ_R) for spread foundations (Table A.5 in EN 1997-1)

Resistance	Symbol	Set		
		R1	R2	R3
Bearing	$\gamma_{R,v}$	1,0	1,4	1,0
Sliding	$\gamma_{R,h}$	1,0	1,1	1,0

Table 5.3.6 Partial resistance factors (γ_R) for retaining structures (Table A.13 in EN 1997-1)

Resistance	Symbol	Set		
		R1	R2	R3
Bearing capacity	$\gamma_{R,v}$	1,0	1,4	1,0
Sliding resistance	$\gamma_{R,h}$	1,0	1,1	1,0

Earth resistance	$\gamma_{R,e}$	1,0	1,4	1,0
------------------	----------------	-----	-----	-----

5.3.2.3 Design approach 3 (DA3)

Only one combination should be used to check that the ULS is not reached. Safety is applied on both actions (factors γ_F) and on the geotechnical resistance R_d , through partial material factors $\gamma_M > 1,0$, applied at the 'source' to the ground parameters themselves. This writes:

$$E_d \{ \gamma_F F_{rep}; X_k / \gamma_M \} \leq R_d \{ X_k / \gamma_M \} \quad (5.5)$$

The recommended values for the actions are given:

- for 'structural' actions, in *Note 2 of Table A2.4 (B) of EN 1990, for Eqn.6.10:*

$$\gamma_{G,sup} = 1,35; \gamma_{G,inf} = 1,00 \text{ and } \gamma_Q = 1,20 \text{ to } 1,50 \text{ or } 0$$

and

- for 'geotechnical' actions, in the *Note of Table A2.4 (C) of EN 1990 for Eqn.6.10:*

$$\gamma_{G,sup} = 1,00; \gamma_{G,inf} = 1,00; \gamma_{G,set} = 1,00 \text{ or } 0; \text{ and } \gamma_Q = 1,15 \text{ to } 1,30 \text{ or } 0.$$

The recommended values of partial material factors γ_M for ground parameters are those of set M2 of Table 5.3.4.

5.3.2.4 Summary for DA1, DA2 and DA3 (for "fundamental" combinations)

For spread foundations and retaining structures, the three Design Approaches, for ULS in permanent and transient design situations, can be summarised in a symbolic manner with sets A, M and R of Tables 5.3.3, 5.3.4, 5.3.5 and 5.3.6, as follows ("+" means "to be combined with"):

1. Design Approach 1 (DA1)
Combination 1: A1 "+" M1 "+" R1
Combination 2: A2 "+" M2 "+" R1
2. Design Approach 2 (DA2)
Combination: A1 "+" M1 "+" R2
3. Design Approach 3 (DA3)
Combination: (A1⁷ or A2⁸) "+" M2 "+" R3

For the design of axially loaded piles and anchors, see *EN 1997-1 (CEN, 2004)*.

⁷ on structural actions

⁸ on geotechnical actions

5.4 Column B2 - design of foundation

5.4.1. Bearing capacity (ULS)

The ULS condition is (Eqn.6.1 in EN 1997-1):

$$N_d \leq R_d \quad (5.6)$$

where

N_d is the design value of the axial component acting on the base of the foundation, due to structural and geotechnical actions;

R_d is the design value of the resistance of the ground (ground bearing capacity) below the base of the foundation.

Geotechnical resistance (bearing capacity)

The resistance R (bearing capacity) is calculated with the sample method of Annex D of EN 1997-1 (CEN, 2004) – see Annex 1 below. I

For undrained conditions (with $\alpha = 0$ and $q = 0$) as in the present case, R may be expressed as:

$$R = A' (\pi+2) c_u s_c i_c \quad (5.7)$$

with $A' = B' L' = (B-2e_B)(L-2e_L)$

$$s_c = 1+0,2 B'/L'$$

$$i_c = \frac{1}{2} \left(1 + \sqrt{1 - \frac{H}{A' c_u}} \right)$$

H being the resultant horizontal force (resultant of V_y and V_z)

Eccentricity is calculated by:

- in the transversal (B) direction: $e_B = M_y/N$
- in the longitudinal (L) direction: $e_L = M_z/N$

For the calculations of e_B , e_L , s_c and i_c , the design values N_d , V_{yd} and V_{zd} , as well as M_{zd} and M_{yd} , which depend on the Design Approach under consideration, are needed. Thus the resistance depends on the actions, which is quite common in geotechnical engineering (because of this, it is sometimes necessary to check the calculations both with unfavourable and favourable values of a number of actions...).

Partial factors γ_M on c_u and $\gamma_{R,v}$ on the bearing capacity R are taken from the recommended values in Tables 5.3.4 and 5.3.5 respectively, for each Design Approach.

For DA1-1, DA2 and DA3, N_d , V_{yd} and V_{zd} , M_{zd} and M_{yd} are given in Table 5.3.1 (derived with set A1 on actions – see Table 5.3.3). The governing combination of actions is taken as the one with the largest value of N_d :

$$\begin{array}{lll} N_d = 5,81 \text{ MN} & V_{yd} = -4,53 \cdot 10^{-3} \text{ MN} & V_{zd} = -1,54 \cdot 10^{-3} \text{ MN} \\ M_{yd} = -2,36 \cdot 10^{-3} \text{ MNm} & M_{zd} = -4,49 \cdot 10^{-3} \text{ MNm} & H_d = 4,78 \cdot 10^{-3} \text{ MNm} \end{array}$$

H_d is the resultant of V_{yd} and V_{zd} . Horizontal loads and moments on this foundation seem negligible.

For DA1-2, these loads have to be divided by a factor somewhere between 1,11 and 1,35, depending on the ratio of permanent G to variable loads Q .

For DA1-1, DA2 and DA3

$$e_B = 4,1 \cdot 10^{-4} \text{ m (!)}, e_L = 7,8 \cdot 10^{-4} \text{ m (!)}, B' \approx B \text{ and } L' \approx L \text{ and } s_c = 1,2$$

Correction factor i_c , and the total resistance R also depend on the Design Approach through γ_M (on c_u) and $\gamma_{R,v}$ (see Tables 5.3.4 and 5.3.5).

Design Approach 1

Combination DA1-1: $\gamma_M = 1,0$; $\gamma_{R,v} = 1,0$

thus $c_{ud} = 300 \text{ kPa}$; $s_c \approx 1,2$, $i_c \approx 1$

and $R_d = 4 \cdot 5,14 \cdot 1,2 \cdot 1 \cdot 300 \cdot 10^{-3} / 1,0 = 7,4 / 1,0 = 7,4 \text{ MN}$ and $N_d \leq R_d$ is verified.

Combination DA1-2: $\gamma_M = 1,4$; $\gamma_{R,v} = 1,0$

thus: $c_{ud} = 300 / 1,4 = 214 \text{ kPa}$; $s_c \approx 1,2$, $i_c \approx 1$

and $R_d = 4 \cdot 5,14 \cdot 1,2 \cdot 1 \cdot 214 \cdot 10^{-3} / 1,0 = 5,28 / 1,0 = 5,28 \text{ MN}$

Let us assume that N_d is equal to N_d for A1-1 divided by 1,11, thus $N_d = 5,23 \text{ MN}$ and $N_d \leq R_d$ is verified.

According to DA1, the foundation is safe with regard to bearing capacity of the ground.

Design Approaches 2 and 3

Design Approaches 2 and 3 yield the same level of safety, because one of the values for the factors γ_M and $\gamma_{R,v}$ is equal to 1,4 and the other one is equal to 1,0.

thus $R_d = 4 \cdot 5,14 \cdot 1,2 \cdot 1 \cdot 300 \cdot 10^{-3} / 1,4 = 5,28 \text{ MN}$.

thus $N_d \leq R_d$ is not verified.

It can be seen easily that the size of the footing should be around:

$A' = 1,4 \times N_d / (\pi + 2) c_u s_c i_c \approx 4,39$, that is, say: $B = L = 2,10 \text{ m}$. The difference with the assumed $B = 2,0 \text{ m}$ is small.

5.4.2. Sliding (ULS)

The basic equation (Eqn. 6.2 in EN 1997-1) is:

$$H_d \leq R_d + R_{p,d} \tag{5.8}$$

where

H_d is the design value of the horizontal component of the load acting on the base of the foundation;

$R_{p,d}$ is the passive earth force in front of the spread foundation, which, for simplicity is not considered here as in order to take into account any passive force the earth has to be properly in contact in front of the footing and well compacted, which is not always the case.

R_d is the sliding resistance, which for undrained conditions is (Eqns. 6.4a and 6.4b in EN 1997-1):

$$R_d = \{ A'_{cu} / \gamma_M \} / \gamma_{R,h} \tag{5.9}$$

where γ_M and $\gamma_{R,h}$ are taken from the recommended values in Tables 5.3.4 and 5.3.6 respectively, for each Design Approach in persistent transient design situations.

As for the bearing capacity, the sliding resistance in undrained conditions also depends on the values of the actions (through $A' = B' L'$, which itself depends on the eccentricities); in drained conditions the sliding resistance is moreover directly proportional to the vertical load, which is thus a favourable action - and its design value should be obtained using the factors for favourable actions.

The largest value of H_d for persistent transient design situations (fundamental combinations) is – see Table 5.3.1:

$H_d = 5,03$ kN (which is quite small) with

$M_{yd} \approx -2,09 \cdot 10^{-3}$ MNm, $M_{zd} \approx -4,70 \cdot 10^{-3}$ MNm, $N_d \approx 5,5$ MN (for DA1-1, DA2 and DA3).

The eccentricities e_B and e_L remain negligible and $B' \approx B$ and $L' \approx L$. Thus $A' \approx BL \approx 4\text{m}^2$.

Design Approach 1

Combination DA1-1: $\gamma_M = 1,0$; $\gamma_{R,h} = 1,0$

thus $c_{ud} = 300$ kPa and $R_d = 4 \cdot 0,300 / 1,0 = 1,2$ MN and $H_d \leq R_d$ is largely verified.

Combination DA1-2: $\gamma_M = 1,4$; $\gamma_{R,h} = 1,0$

thus $c_{ud} = 300/1,4 = 214$ kPa and $R_d = 4 \cdot 0,214 / 1,0 = 0,86$ MN, with $H_d < 5,03$ kN

and $H_d \leq R_d$ is largely verified.

According to DA1, the foundation is safe with regard to sliding.

Design Approach 2 $\gamma_M = 1,0$; $\gamma_{R,h} = 1,1$

thus $c_{ud} = 300$ kPa and $R_d = 4 \cdot 0,300 / 1,1 = 1,09$ MN

and $H_d \leq R_d$ is largely verified.

Design Approach 3 $\gamma_M = 1,4$; $\gamma_{R,h} = 1,0$

thus $c_{ud} = 300/1,4 = 214$ kPa and $R_d = 4 \cdot 0,214 / 1,0 = 0,86$ MN

and $H_d \leq R_d$ is largely verified.

5.5 Comments on settlements (SLS)

5.5.1. Compensated foundation

The total weight of the present building is less than the weight of the ground removed to build the underlying parking.

Assuming for the weight density of the ground $\gamma = 20$ kN/m³, the initial pressure at the base level of the excavation is around $(3 \cdot 20)$ kN/m³ = 60 kPa. Thus, settlements will be limited as the construction of the building simply consists in partly “putting back” something similar to the ground in its initial position.

For this type of foundation, called “compensated foundation”, in practice settlements are ignored. Nevertheless, for the sake of illustration, various assumptions are made in order to estimate the maximum possible settlement.

Settlements are usually checked under the vertical load Q obtained with quasi-permanent SLS combinations. For column B2, from Table 5.3.1:

$$Q = 4,2 \text{ MN}$$

which corresponds to the applied pressure on the ground:

$$q = Q / (BL) = 4,2 / (2 \cdot 2) = 1,05 \text{ MPa.}$$

5.5.2. Calculation based on the results of Ménard pressuremeter method

Eurocode 7 – Part 2 (EN1997-2) provides, in informative Annexes, several methods for determining the settlement of spread foundations. In the following the *Ménard* pressuremeter (MPM) method is used, described in *Annex E.2 of EN 1997-2 (CEN, 2002)*.

The settlement is expressed as:

$$s = (q - \sigma_{v0}) \times \left[\frac{2B_0}{9E_d} \times \left(\frac{\lambda_d B}{B_0} \right)^a + \frac{\alpha \lambda_c B}{9E_c} \right] \quad (5.10)$$

In the current case:

$$q = 1,05 \text{ MPa}$$

$\sigma_{v0} = 0$ assumed for simplicity, as if the soil is simply loaded from its initial natural level (without the unloading due to the excavation)

$$B = 2 \text{ m}$$

$$B_0 = 0,6 \text{ m}$$

For a square foundation: thus $\lambda_d = 1,12$ and $\lambda_c = 1,1$

For an overconsolidated clay in Eqn. (5.10) the exponent α may be assumed $\alpha = 1,0$

The *Ménard* pressuremeter modulus is assumed to be constant over depth and equal, as a minimum, for highly overconsolidated clays to 16 times the limit pressure, his one being equal to $9c_u$ on average (c_u is the undrained shear strength of the clay - see e.g., *Frank, 1999 and Baguelin, et al. , 1978*)

$$E_M \approx (9 \cdot 16) c_u = 144 \cdot 300 \cdot 10^{-3} = 43 \text{ MPa}$$

$$E_d = E_c = 43 \text{ MPa}$$

$$s_{B2} = (1,05 - 0,00) \cdot [(2 \cdot 0,6 \cdot 1,12 \cdot 2) / (9 \cdot 43 \cdot 0,6) + (1 \cdot 1,1 \cdot 2,0) / (9 \cdot 43)] =$$

$$1,05 \cdot [0,0116 + 0,0057] = 0,017 \text{ m} = 17 \text{ mm.}$$

The span between two columns is $L = 6 \text{ m}$: assuming that the differential settlement $\delta_s = s_{B2}/2$, the relative rotation is:

$$b = s_{B2} / 2L = 8,5 / 6000 = 1,4 \cdot 10^{-3}$$

Annex H of EN 1997-1 (informative) states that for buildings in the most of cases a relative rotation $\beta = 1/500 = 2 \cdot 10^{-3}$ is acceptable. If this building was just built to “rest” on the stiff clay loaded from its natural level (with no excavation at all), the differential settlement would be clearly acceptable.

Furthermore, some conservative assumptions have been made: for instance, it is most likely that the stiffness of the clay would increase with depth.

5.5.3. Adjusted elastic method

Eurocode 7 - Part 1 (CEN, 2004) allows the use of pseudo-elastic methods written under the form:

$$s = qBf / E_m \quad (5.11)$$

where E_m is the design value of the modulus of elasticity.

This method assumes that an estimate of an equivalent and unique Young's modulus value is possible to represent the ground affected by the load and for the correct level(s) of deformation...

All the difficulty lies in the assessment of E_m . For the Fort Canning Tunnel in Singapore, *Mair (2011)* quotes a value of the undrained modulus E_u for the hard clay matrix $E_u \approx 500$ MPa, from back-analysis of settlements of buildings on rafts. Note that the undrained shear strength of the Singapore clay matrix is $c_u > 150$ kPa.

The value for E_u is consistent with unload-reload moduli from pressuremeter tests and moduli from plate loading tests in the same clay. Thus, it would be 10 times the "first loading" modulus E_M obtained with the Ménard pressuremeter quoted above, which is not surprising.

The elastic calculation (Eqn.5.11) leads to:

$$s_{B2} = 1,05 \cdot 2,0 \cdot 0,66 / 500 = 0,0023 = 2,8 \text{ mm.}$$

This settlement, largely less to the one calculated using the first loading *Ménard* modulus together with the *Ménard* empirical formula (Eqn. 5.10), is probably more realistic, as an elastic approach is more appropriate for the reloading phase of the clay (after excavation). The result confirms that the settlement of such a "compensated" foundation can be ignored in practice.

References

- Baguelin, F., Jézéquel, J.F., Shields, D.H. (1978). The Pressuremeter and Foundation Engineering. Trans Tech Publications, Clausthal, Germany.*
- CEN 2002. Eurocode: Basis of structural design. EN 1990: 2002. European Committee for Standardization (CEN): Brussels.*
- CEN 2004. Eurocode 7: Geotechnical design - Part 1: General rules. EN 1997-1:2004 (E), November 2004, European Committee for Standardization: Brussels.*
- CEN 2007. Eurocode 7: Geotechnical design - Part 2: Ground investigation and testing. EN1997-2:2007 (E), March 2007, European Committee for Standardization: Brussels.*
- Frank R. 1999. Calcul des fondations superficielles et profondes, Presses de l'Ecole des ponts et Techniques de l'ingénieur, Paris.*
- MELT-Ministère de l'Équipement, du logement et des transports 1993. Règles Techniques de Conception et de Calcul des Fondations des Ouvrages de Génie Civil (in French: Technical Rules for the Design of Foundations of Civil Engineering Structures). Cahier des clauses techniques générales applicables aux marchés publics de travaux, FASCICULE N°62 -Titre V, Textes Officiels N° 93-3 T.O., 182 pages.*

ANNEX 1

From EN 1997-2 (CEN, 2004): Annex D (informative): A sample analytical method for bearing resistance calculation.

Annex D.3: Undrained conditions

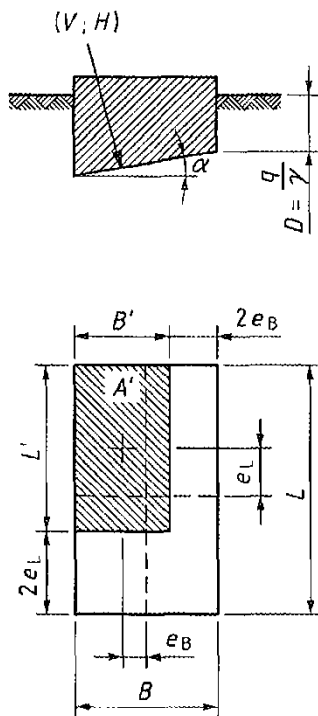

The following symbols are used in Annex D.3

$A' = B' \times L'$	the design effective foundation area
b	the design values of the factor for the inclination of the base, with subscript c (with subscripts q and γ , only used for drained conditions)
B	the foundation width
B'	the effective foundation width
D	the embedment depth
e	the eccentricity of the resultant action, with subscripts B and L
i	the inclination factor of the load, with subscript c (with subscripts q and γ for drained conditions only)
L	the foundation length
L'	the effective foundation length
q	overburden or surcharge pressure at the level of the foundation base
s	the shape factor of the foundation base, with subscript c (with subscripts q and γ for drained conditions only)
V	the vertical load
α	the inclination of the foundation base to the horizontal
γ	weight density of the soil below the foundation level

The notations used are given in Figure D.1.

Figure D.1 — Notations

D.3 Undrained conditions

The design bearing resistance may be calculated from:

$$R/A' = (\pi+2) c_u b_c s_c i_c + q \quad (D.1)$$

with the dimensionless factors for:

- the inclination of the foundation base: $b_c = 1 - 2\alpha / (\pi + 2)$;
- the shape of the foundation:

$$s_c = 1 + 0,2(B'/L') \quad \text{for a rectangular shape;}$$

$$s_c = 1,2 \quad \text{for a square or circular shape.}$$

ANNEX 2

From EN 1997-2 (CEN, 2004): Annex E (informative): E.2 Example of a method to calculate the settlements for spread foundations

The following is an example of a method to calculate the settlement s , of spread foundations using a semi-empirical method developed for MPM tests. The example was published by the French *Ministère de l'Équipement du Logement et des Transport* (1993). For additional information and examples, see EN1997-2, Annex X, §X.3.2.

$$s = (q - \sigma_{v0}) \times \left[\frac{2B_0}{9E_d} \times \left(\frac{\lambda_d B}{B_0} \right)^a + \frac{\alpha \lambda_c B}{9E_c} \right]$$

where

- B_0 is a reference width of 0,6 m;
- B is the width of the foundation;
- λ_d, λ_c are shape factors given in Table E.2;
- α is a rheological factor given in Table E.3;
- E_c is the weighted value of E_M immediately below the foundation;
- E_d is the harmonic mean of E_M in all layers up to $8B$ below the foundation;
- σ_{v0} is the total (initial) vertical stress at the level of the foundation base;
- q is the design normal pressure applied on the foundation.

Table E.2 — The shape coefficients, λ_c , λ_d , for settlement of spread foundations

L/B	Circle	Square	2	3	5	20
λ_d	1	1,12	1,53	1,78	2,14	2,65
λ_c	1	1,1	1,2	1,3	1,4	1,5

Table E.3 — Correlations for deriving the coefficient α for spread foundations

Type of ground	Description	E_M/ρ_{LM}	α
Peat			1
Clay	Over-consolidated	<16	1
	Normally consolidated	9–16	0,67
	Remoulded	7–9	0,5
Silt	Over-consolidated	>14	0,67
	Normally consolidated	5–14	0,5
Sand		>12	0,5
		5–12	0,33
Sand and gravel		>10	0,33
		6–10	0,25
Rock	Extensively fractured		0,33
	Unaltered		0,5
	Weathered		0,67

CHAPTER 6

FIRE RESISTANCE ACCORDING TO *EN 1992-1-2*

Caroline MORIN and Fabienne ROBERT

CERIB, France

6.1 Introduction

Fire is a definite danger to any construction and needs to be prevented and fought by all possible means. The fire may occur anywhere, in any session and in any phase in the lifetime of a building (construction, service, refurbishment or demolition).

The aim of this chapter is to give a general overview of the fire design according to Eurocodes (*EN 1990*, *EN 1991-1-2* and *EN 1992-1-2*) through the example out of the concrete building. The fire load-bearing capacity of three concrete members (a column, a beam and a slab) will be determined. The global analysis of the overall structure is not covered.

EN 1990 concerns the basis of structural design. *EN 1991-1-2* describes the thermal and mechanical actions for the structural design of building exposed to fire. *EN 1992-1-2* describes the principles, requirements and rules for the structural design of concrete buildings for the accidental situation of fire exposure, including the safety requirements, design procedure and design aids. *EN 1991-1-2* and *EN 1992-1-2* are intended to be used in conjunction with *EN 1991-1-1* and *EN 1992-1-1*.

In this chapter, the prescriptive approach is adopted (in opposite to the performance-based code), i.e. it uses nominal fires to generate thermal actions like the standard temperature-time curve (*EN 1991-1-2*, Sec-3).

Fire resistance is defined as “..the ability of a structure, a part of a structure or a member to fulfil its required functions (load bearing function and/or fire spreading function) for a specified load level, for a specified fire exposure and for a specified period of time...”.

The methods given in *EN 1992-1-2* are applicable since concrete materials used in the building are normal weight concrete materials with strength class less than the limit strength class C90/105.

In this chapter the different methods given in *EN 1992-1-2*, Sec-4 are used:

- tabulated data (*EN 1992-1-2*, Sec 5);
- simplified calculation methods (*EN 1992-1-2*, Sec-4);

EN 1992-1-2 gives alternative procedures, values and recommendations for classes with notes indicating where national choices have to be made. Therefore the National Standard implementing *EN 1992-1-2* should have a National Annex containing the Eurocode all Nationally Determined Parameters to be used for the design of buildings, and where required and applicable, for civil engineering works to be built in the relevant country. For this example, the French National Annex has been selected.

6.2 Data concerning building

6.2.1. Description of the building

The building is described in 1.2.1, Chapter 1. The plan view and the main sections of the building are given in Figure 6.2.1 to 6.2.4. Focus is on:

- The beam in axis 2 which consists of a continuous beam. Its cross section is a T-beam where its effective width has been calculated in chapter concerning Limit State Design (ULS-SLS). The effective width b_{eff} at mid-span is equal to 2,6 m and at intermediate support is equal to 1,83 m. The length L_{beam} of the continuous beam is equal to 7,125 m. The width b_w of the web is 0,25 m. The height of the slab h_{slab} is 0,18 m. The height of the beam h_{beam} is 0,40 m;
- The 4 m high column B2 is the one in the second basement. Its effective length $l_{0,column}$ has been calculated in the previous chapter concerning ULS-SLS and is equal to 3,1 m. The slenderness λ_{column} of the column at normal temperatures is equal to 22,5. The cross-section is a square of 0,50 m. Its section $A_{c,column}$ is equal to 0,25 m²;

- The slab on the beams (A1B2) is a two-way slab of uniform thickness ($h_{slab} = 0,18$ m). The width of the slab in X-direction l_x is equal to 6 m and the width of the slab in y-direction l_y is equal to 7,125 m.

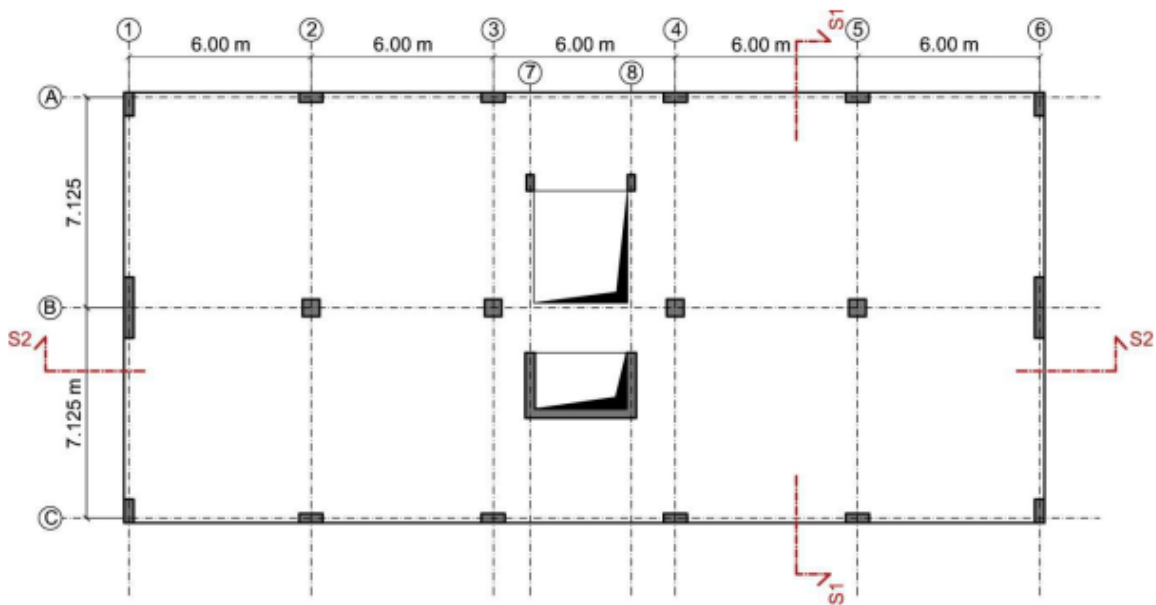

Fig. 6.2.1 Plan view of the slab on beams

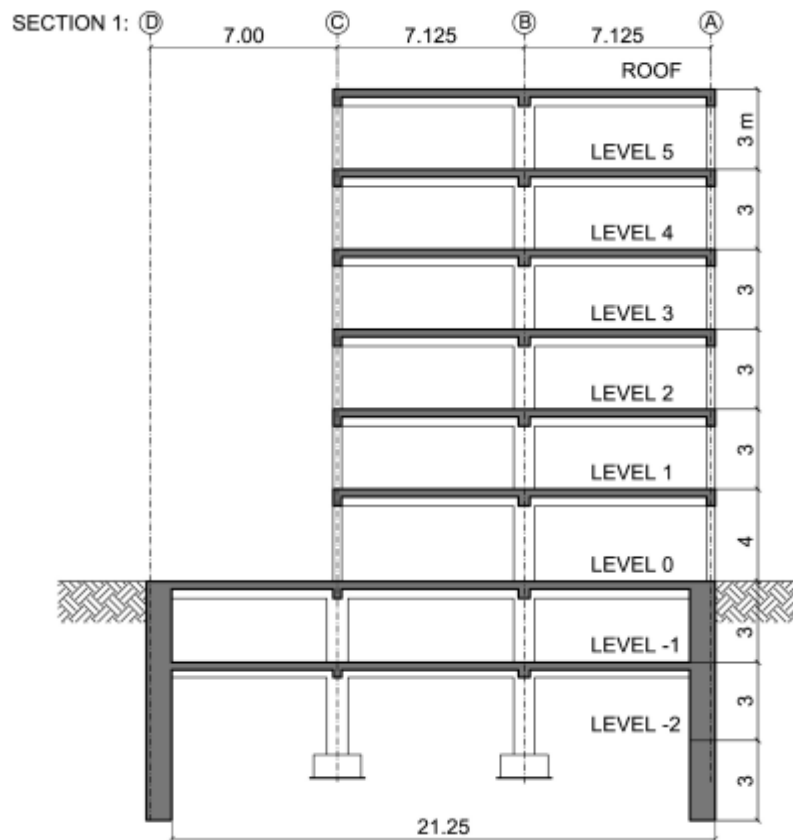

Fig. 6.2.2 Section 1 of the building

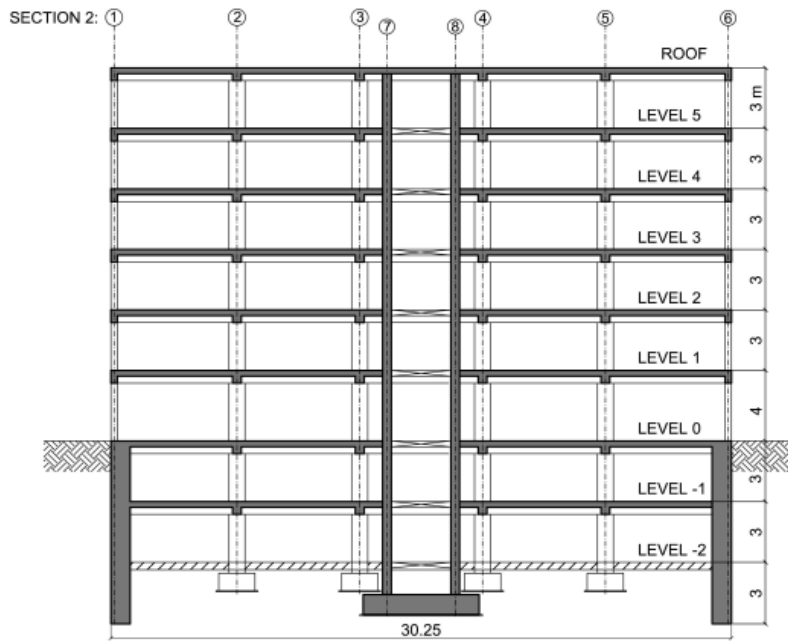

Fig. 6.2.3 Section 2 of the building with the 8 floors

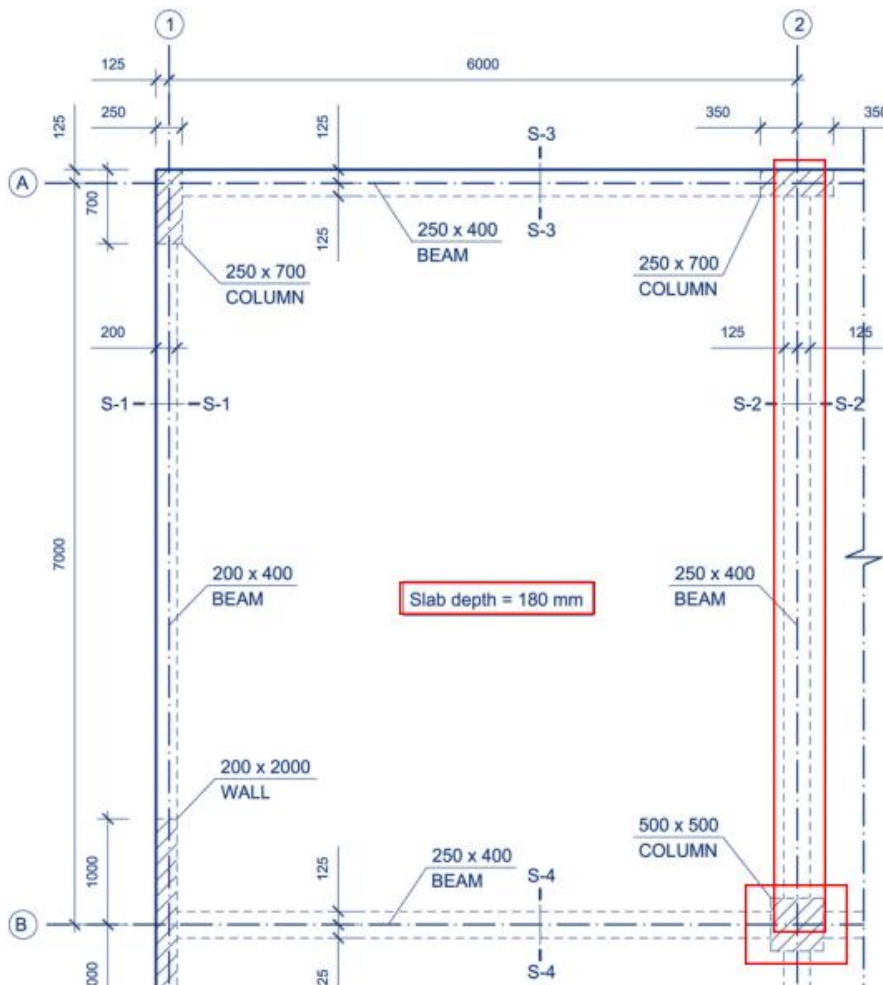

Fig. 6.2.4 Elements verified under fire (dimensions) – column, beam and slab

6.2.2. Mechanical material properties

6.2.2.1 General

The values of material properties shall be considered as characteristic values to be used with simplified and advanced calculation methods. The mechanical properties of concrete and reinforcing steel at normal temperature are given in *EN 1992-1-1* for normal temperature design.

Design values of mechanical (strength and deformation) material properties $X_{d,fi}$ are defined as follows (Eqn 6.1):

$$X_{d,fi} = k_{\theta} X_k / \gamma_{M,fi} \quad (6.1)$$

X_k is the characteristic value of strength or deformation property for normal temperature as described in *EN 1992-1-1*, k_{θ} is the reduction factor for a strength or deformation property dependent on the material temperature ($X_{k,\theta}/X_k$) and $\gamma_{M,fi}$ is the partial safety factor for the relevant material property for the fire situation.

For thermal and mechanical properties of concrete and reinforcing steel, $\gamma_{M,fi}$ is taken equal to 1,0.

Table 6.2.1 gives, for each member, the classes of concrete and reinforcement steel (see Ch.1).

Table 6.2.1 Concrete class and steel class of members

Slab	Beam	Column
C25/30	C25/30	C30/37
Grade 500 class B	Grade 500 class B	Grade 500 class B

The exposure class considered is XC2-XC1. The nominal cover c_{nom} (see Ch.1) due to non-uniformity of EU National choices, to avoid country specific conditions it was fixed to 30 mm.

6.2.2.2 Concrete

The concrete used is assumed to be made of siliceous aggregates. In *EN 1992-1-2*, Sec-3 strength and deformation properties of uniaxially stressed concrete at elevated temperatures are given in terms of stress-strain relationship. This relationship is described by two parameters: the compressive strength $f_{c,\theta}$ and the strain $\epsilon_{c1,\theta}$ corresponding to $f_{c,\theta}$. Values are given in Table 6.2.2, as a function of concrete temperatures.

The reduction factor for concrete strength dependent on the material temperature is in Figure 6.2.5.

Mathematical model for stress-strain relationships of concrete under compression at elevated temperatures is as in Eqn 6.2 for $\epsilon < \epsilon_{c1,\theta}$:

$$\sigma(\theta) = \frac{3 \times \epsilon \times f_{c,\theta}}{\epsilon_{c1,\theta} \times \left(2 + \left(\frac{\epsilon}{\epsilon_{c1,\theta}} \right)^3 \right)} \quad (6.2)$$

For $\epsilon_{c1,\theta} < \epsilon < \epsilon_{cu1,\theta}$ and numerical purposes, a descending branch should be adopted.

Table 6.2.2 Values of the main parameters of the stress-strain relationships - normal concrete with siliceous aggregates (from EN 1992-1-2, Sec-3, Table 3.1)

Temperature (°C)	$f_{c,\theta}/f_{ck}$	$\epsilon_{c,\theta}$	$\epsilon_{c1,\theta}$
20	1.00	0.0025	0.0200
100	1.00	0.0040	0.0225
200	0,95	0.0055	0.0250
300	0.85	0.0070	0.0275
400	0.75	0.0100	0.0300
500	0.60	0.0150	0.0325
600	0.45	0.0250	0.0350
700	0.30	0.0250	0.0375
800	0.15	0.0250	0.0400
900	0.08	0.0250	0.0425
1000	0.04	0.0250	0.0450
1100	0.01	0.0250	0.0475
1200	0.00	-	-

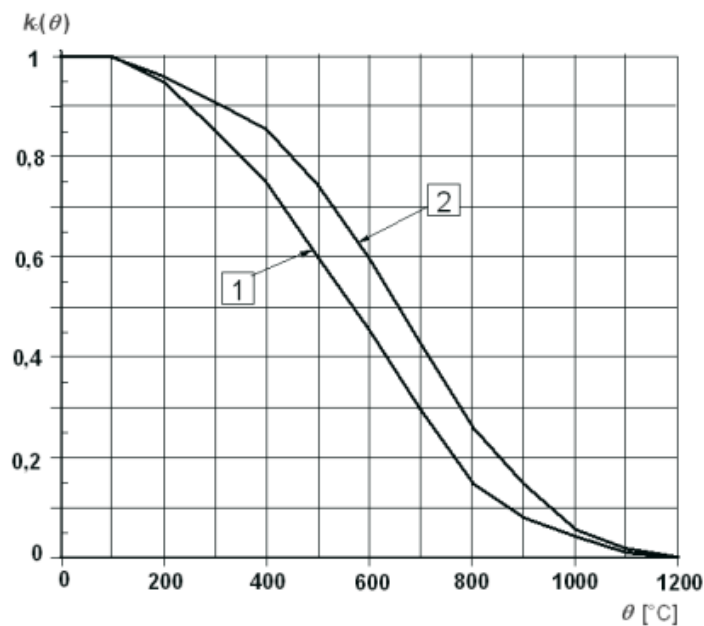

Fig. 6.2.5 Coefficient $k_c(\theta)$ for decrease of concrete strength f_{ck} (1: siliceous aggregates, 2: calcareous aggregates)

6.2.2.3 Reinforcing bars

The reinforcing steel used is cold worked steel. The strength and deformation properties of reinforcing steel at elevated temperatures is obtained from stress-strain relationships described in EN 1992-1-2, Sec-3, defined by three parameters: the slope of the linear elastic range $E_{s,\theta}$, the proportional limit $f_{sp,\theta}$ and the maximum stress level $f_{sy,\theta}$. Values of these parameters are given in Table 6.2.3, as a function of steel temperature.

The mathematical model for stress-strain relationships of reinforcing steel at elevated temperatures is presented in Figure 6.2.6.

Range	Stress $\sigma(\theta)$	Tangent modulus
$\varepsilon_{sp,\theta}$	$\varepsilon E_{s,\theta}$	$E_{s,\theta}$
$\varepsilon_{sp,\theta} \leq \varepsilon \leq \varepsilon_{sy,\theta}$	$f_{sp,\theta} - c + (b/a)[a^2 - (\varepsilon_{sy,\theta} - \varepsilon)^2]^{0,5}$	$\frac{b(\varepsilon_{sy,\theta} - \varepsilon)}{a[a^2 - (\varepsilon - \varepsilon_{sy,\theta})^2]^{0,5}}$
$\varepsilon_{sy,\theta} \leq \varepsilon \leq \varepsilon_{st,\theta}$	$f_{sy,\theta}$	0
$\varepsilon_{st,\theta} \leq \varepsilon \leq \varepsilon_{su,\theta}$	$f_{sy,\theta} [1 - (\varepsilon - \varepsilon_{st,\theta}) / (\varepsilon_{su,\theta} - \varepsilon_{st,\theta})]$	-
$\varepsilon = \varepsilon_{su,\theta}$	0,00	-
Parameter *)	$\varepsilon_{sp,\theta} = f_{sp,\theta} / E_{s,\theta}$ $\varepsilon_{sy,\theta} = 0,02$ $\varepsilon_{st,\theta} = 0,15$ $\varepsilon_{su,\theta} = 0,20$ Class A reinforcement: $\varepsilon_{st,\theta} = 0,05$ $\varepsilon_{su,\theta} = 0,10$	
Functions	$a^2 = (\varepsilon_{sy,\theta} - \varepsilon_{sp,\theta})(\varepsilon_{sy,\theta} - \varepsilon_{sp,\theta} + c/E_{s,\theta})$ $b^2 = c (\varepsilon_{sy,\theta} - \varepsilon_{sp,\theta}) E_{s,\theta} + c^2$ $c = \frac{(f_{sy,\theta} - f_{sp,\theta})^2}{(\varepsilon_{sy,\theta} - \varepsilon_{sp,\theta})E_{s,\theta} - 2(f_{sy,\theta} - f_{sp,\theta})}$	

Fig. 6.2.6 Mathematical model of the reinforcing steel stress-strain relationships at elevated temperatures according to EN 1992-2, Sec-3

Table 6.2.3 Values of the main parameters of the cold worked reinforcing steel stress-strain relationships at elevated temperatures (from EN 1992-1-2, Sec-3, Table 3.2a)

Temperature (°C)	$f_{sy,\theta}/f_{yk}$	$E_{s,\theta}/E_s$
20	1,00	1,00
100	1,00	1,00
200	1,00	0,87
300	1,00	0,72
400	0,94	0,56
500	0,67	0,40
600	0,40	0,24
700	0,12	0,08
800	0,11	0,06
900	0,08	0,05
1000	0,05	0,03
1100	0,03	0,02
1200	0,00	0,00

6.2.3. Materials' physical and thermal properties

Concrete thermal and physical properties are described in EN 1992-1-2, Sec-3 as a function of temperature θ and other variables. Differently from the thermal conductivity, thermal strain $\varepsilon_c(\theta)$, specific heat $c_p(\theta)$ and density $\rho(\theta)$ are not nationally Determined Parameters,

6.2.3.1 Thermal strain of concrete and steel

- Concrete - the strain $\varepsilon_c(\theta)$ at temperature θ of a siliceous concrete is (Fig. 6.2.7):

$$\varepsilon_c(\theta) = -1,8 \cdot 10^{-4} + 9 \cdot 10^{-6} \cdot \theta + 2,3 \cdot 10^{-11} \cdot \theta^3 \quad \text{for } 20^\circ\text{C} \leq \theta \leq 700^\circ\text{C} \quad (6.3)$$

$$\varepsilon_c(\theta) = 14 \cdot 10^{-3} \quad \text{for } 700^\circ\text{C} < \theta \leq 1200^\circ\text{C} \quad (6.4)$$

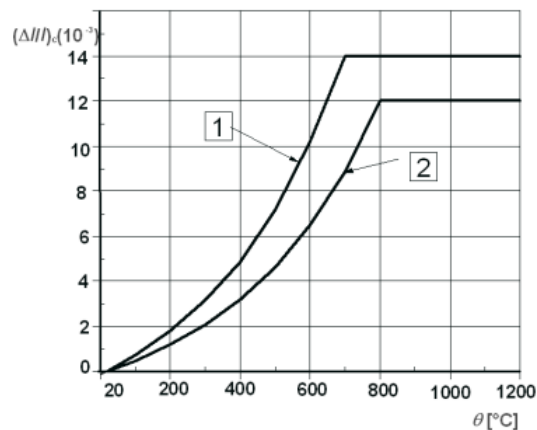

Fig. 6.2.7 Concrete strain f(theta) (1: siliceous aggregates, 2: calcareous aggregates)

- Steel - the strain $\varepsilon_s(\theta)$ at temperature θ of reinforcing steel is (Fig. 6.2.8):

$$\varepsilon_{sc}(\theta) = -2,416 \cdot 10^{-4} + 1,2 \cdot 10^{-5} \cdot \theta + 0,4 \cdot 10^{-8} \cdot \theta^2 \quad \text{for } 20^\circ\text{C} \leq \theta \leq 750^\circ\text{C} \quad (6.5)$$

$$\varepsilon_c(\theta) = 11 \cdot 10^{-3} \quad \text{for } 750^\circ\text{C} < \theta \leq 860^\circ\text{C} \quad (6.6)$$

$$\varepsilon_{sc}(\theta) = -6,2 \cdot 10^{-3} + 2 \cdot 10^{-5} \cdot \theta \quad \text{for } 860^\circ\text{C} < \theta \leq 1200^\circ\text{C} \quad (6.7)$$

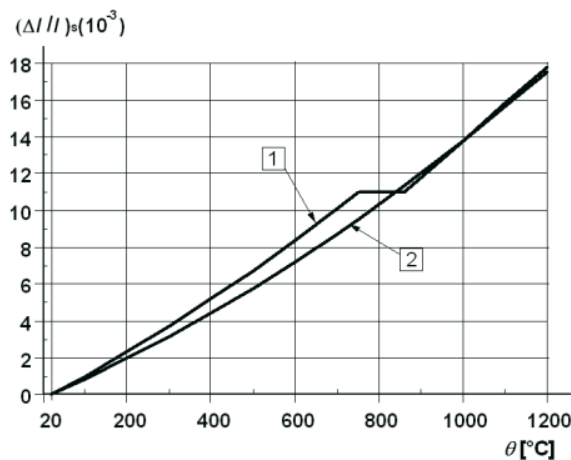

Fig.6.2.8 Steel strain f(theta) (1: reinforcing steel, 2: prestressing steel)

6.2.3.2 Concrete specific heat

Calculations in the following are based on a moisture content $u=1,5\%$ of concrete weight. Figure 6.2.9 illustrates the variation of the specific heat as a function of concrete temperature θ : for $u=1,5\%$ the value of $c_{p,peak}$ is $1470\text{ J/kg}^\circ\text{K}$.

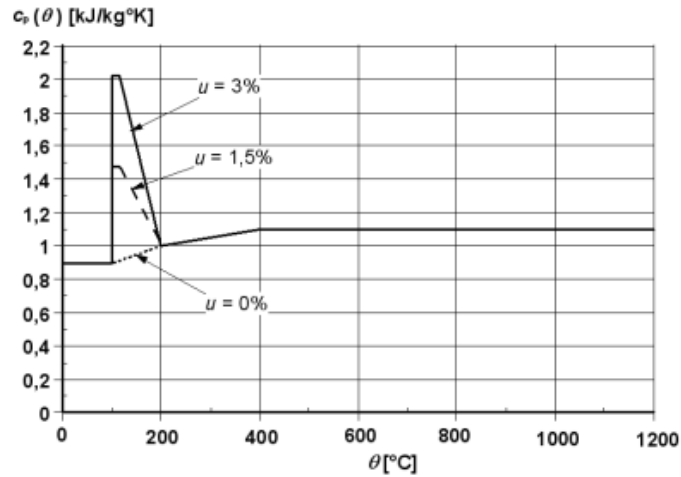

Fig. 6.2.9 Specific heat $c_p, f(\theta)$ and moisture contents by weight - siliceous concrete

6.2.3.3 Concrete thermal conductivity

The variation of concrete thermal conductivity λ_c with temperature is set by the National annex within a range defined by lower and upper limits. For the following calculations, Eqns. 6.8, 6.9 and 6.10 were adopted, which correspond to the curves in Figure 6.2.10 described in the French National Annex.

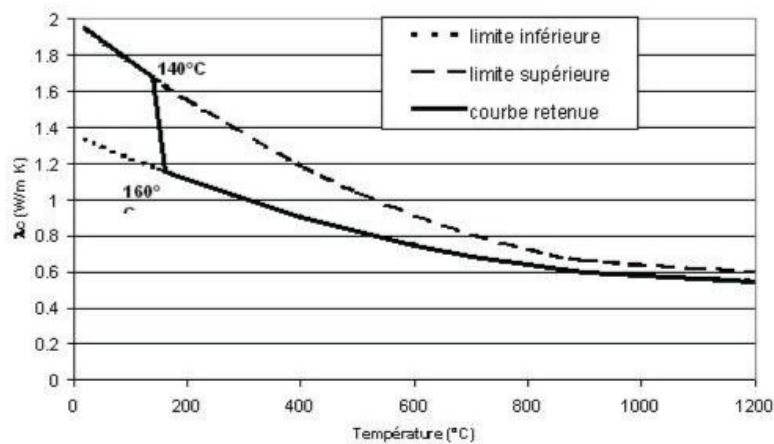

Fig. 6.2.10 Thermal conductivity of concrete (French National Annex of EN 1992-1-2)

$$\lambda_c = 2 - 0,2451(\theta/100) + 0,0107(\theta/100)^2 \text{ W/mK} \quad \theta \leq 140^\circ\text{C} \quad (6.8)$$

$$\lambda_c = -0,02604\theta + 5,324 \text{ W/mK} \quad 140 < \theta \leq 160^\circ\text{C} \quad (6.9)$$

$$\lambda_c = 1,36 - 0,136(\theta/100) + 0,0057(\theta/100)^2 \text{ W/mK} \quad \theta \geq 160^\circ\text{C} \quad (6.10)$$

6.2.3.4 Density of concrete and reinforcing bars

The variation of density with temperature influenced by water loss is described in EN 1992-1-2, Sec-3.

6.2.4. Reinforced members' sections (column, beam and slab)

6.2.4.1 Column B2

According to Chapter 3, the column reinforcement is made of 12 ϕ 20 (37,69 cm²) in a symmetric manner with stirrups ϕ 12/200 mm (Figure 6.2.11 and Table 6.2.4).

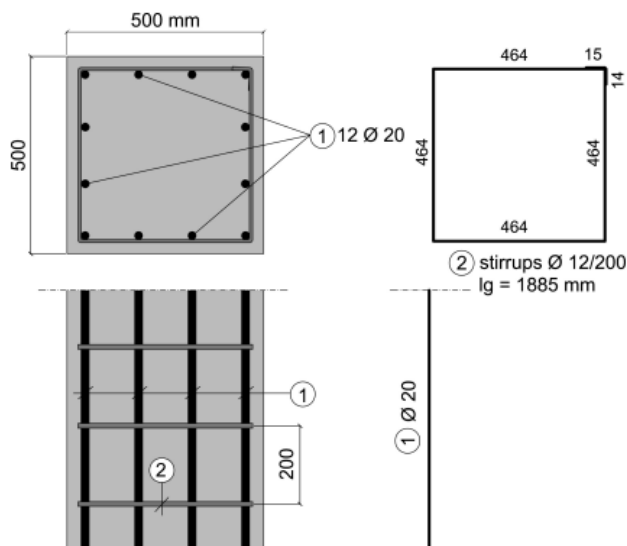

Fig. 6.2.11 Layout of the reinforced column B2

Table 6.2.4 Steel reinforcement of column B2

Longitudinal	Transversal
12 ϕ 20	ϕ 12/200 mm

The axis distance of the longitudinal steel bars from the concrete surface is:

$$a_{column}: (30 + 12 + 20/2) \text{ mm} = 52 \text{ mm.}$$

6.2.4.2 Beam in axis 2

The beam in axis 2 is a continuous beam with spans 7,125 m long, reinforced as in Table 6.2.5.

Table 6.2.5 Steel longitudinal (lower/upper) and transversal reinforcement of beam in axis 2

Title 1	Perimeter support	Middle span	Intermediate support
Upper	7 ϕ 12	2 ϕ 10	9 ϕ 12
Lower	3 ϕ 16	3 ϕ 16	3 ϕ 16
Stirrups	ϕ 6/175	ϕ 6/175	ϕ 6/175

At middle span, the axis distance $a_{mid-span,beam}$ of steel reinforcement from the nearest exposed surface is 44 mm. At support, the axis distance $a_{support,beam}$ of steel reinforcement from the nearest non-exposed surface is 42 mm.

6.2.4.3 Slab on beams

For this study only one type of horizontal slabs, i.e. slab on beams, is considered. The slab thickness h_{slab} is 0,18 m. The slab reinforcement is in Figure 6.2.12 and in Table 6.2.6 and Table 6.2.7.

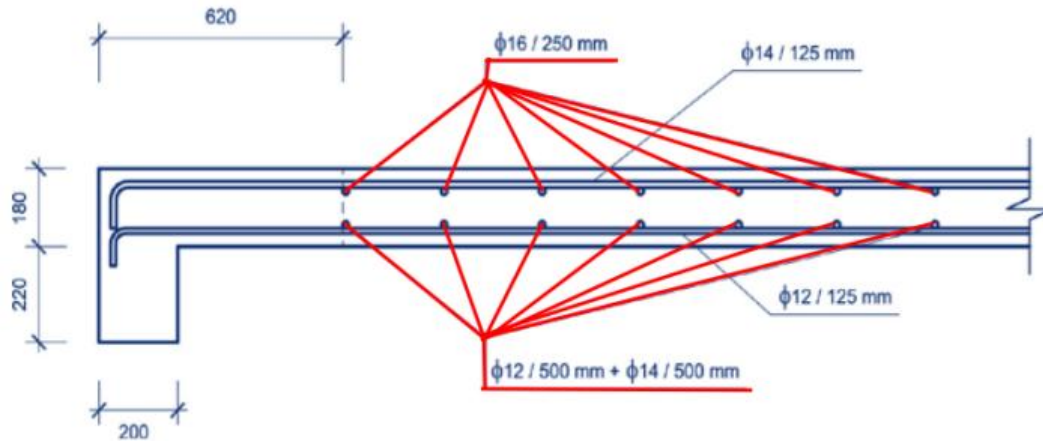

Fig. 6.2.12 Layout of the reinforced slab

Table 6.2.6 Longitudinal reinforcement of the slab in x-direction

Title 1	Perimeter beam strip (1,75 m)	Middle strip (3,5 m)	Intermediate beam strip (1,75 m)
Upper	$\phi 14/250$ mm	$\phi 14/125$ mm	$\phi 14/250$ mm
Lower	$\phi 12/250$ mm	$\phi 12/125$ mm	$\phi 12/250$ mm

Table 6.2.7 Longitudinal reinforcement of the slab in y-direction

Title 1	Perimeter beam strip (1,5 m)	Middle strip (3 m)	Intermediate beam strip (1,5 m)
Upper	$\phi 16/250$ mm	$\phi 16/125$ mm	$\phi 16/250$ mm
Lower	$\phi 12/500$ mm $\phi 14/500$ mm	$\phi 12/250$ mm $\phi 14/250$ mm	$\phi 12/500$ mm $\phi 14/500$ mm

The axis distance $a_{x,slab}$ of reinforcing steel in x-direction from the nearest exposed surface is :

$$a_{x,slab} = c_{nom} + \frac{\varphi_x}{2} = 30 + \frac{12}{2} = 36 \text{ mm} \quad (6.11)$$

The axis distance $a_{y,slab}$ of reinforcing steel in Y-direction from the nearest exposed surface is :

$$a_{y,slab} = c_{nom} + \varphi_x + \frac{\varphi_y}{2} = 30 + 12 + \frac{14}{2} = 49 \text{ mm} \quad (6.12)$$

6.2.5.

Actions

The thermal and mechanical actions are taken from EN 1991-1-2. These actions, considered at normal temperature, shall be applied because they are likely to act in fire situation. The emissivity

related to the concrete surface is taken as 0,7 (EN 1992-1-2, Sec-2). The following actions are considered:

- Dead weight G_{slab} based on reinforced concrete unit weight of 25 kN/m^3 and on the geometry of the slab;
- Imposed permanent actions G_{imp} (finishing, pavement, embedded services and partitions);
- Variable actions Q_1 .

To obtain the relevant effects of actions $E_{fi,d,t}$ during fire exposure, the mechanical actions are combined in accordance with EN 1990 for accidental design situations. In France, the representative value of the variable action Q_1 is the frequent value $\psi_{1,1}Q_1$. ($\psi_{1,1} = 0,5$ for dwellings - EN 1990, Annex A, Table A1.1).

The design loads are $L_{Ed} = 13,125 \text{ kN/m}^2$ at normal temperatures and $L_{Ed,fi} = 8,5 \text{ kN/m}^2$ under fire - see Table 6.2.8. The ratio $L_{Ed,fi}/L_{Ed}$ is equal to 0,65.

Table 6.2.8 External actions on slabs

G_{slab}	G_{imp}	Q_1	$L_{Ed,fi}$
4,5 kN/m ²	3 kN/m ²	2 kN/m ²	8,5 kN/m ²

The ratio I_x/I_y is equal to 0,84. The design isostatic moment in X-direction $M_{0Ed,fi,x-slab}$ is $\mu_x = 0,052$. The design isostatic moment in y-direction $M_{0Ed,fi,y-slab}$ is $\mu_y = 0,671$ and is equals to $\mu_y M_{0Ed,fi,x-slab}$.

For beam in axis 2, the maximum bending moments in the fire situation can be obtained multiplying by 0,65 the design moments in chapter 3 . The resulting isostatic moment $M_{0Ed,fi,beam}$ is 128,7 kN.m.

For column, the normal force $N_{Ed,fi}$ under fire is 2849 kN (the design normal force N_{Ed} is 4384 kN) and the bending moment at the ends $M_{Ed,fi,column}$ under fire is 14 kN.m.

Actions acting on slab, beam and column are summed up in Table 6.2.9.

Table 6.2.9 Exterior actions acting on beam (axis 2) and on the column B2

$M_{0Ed,fi,x-slab}$	$M_{0Ed,fi,y-slab}$	$M_{0Ed,fi,beam}$	$N_{Ed,fi,column}$	$M_{Ed,fi,column}$
15,9 kN.m	10,7 kN.m	128,7 kN.m	2849 kN	14 kN.m

6.3 Tabulated data

6.3.1. Scope

Where simple calculation models are not available, the Eurocode fire parts give design solutions in terms of tabulated data (based on tests or advanced calculation methods), to be used within the specified limits of validity. In this case the member is assumed as isolated. Indirect fire actions are not considered, except those resulting from thermal gradients.

Tabulated data are verified design solutions for a standard fire exposure up to 240 minutes. The values, given in tables in terms of minimal cross-sectional dimensions and of minimum nominal axis distance, apply to normal weight concrete made with siliceous aggregates (Figure 6.3.1). Using tabulated data, according to EN 1992-1-2, Sec-5 no further checks are required concerning shear and torsion capacity and spalling.

Tabulated data are based on a reference load level $\eta_{fi} = 0,7$. Linear interpolation between values in the tables may be carried out.

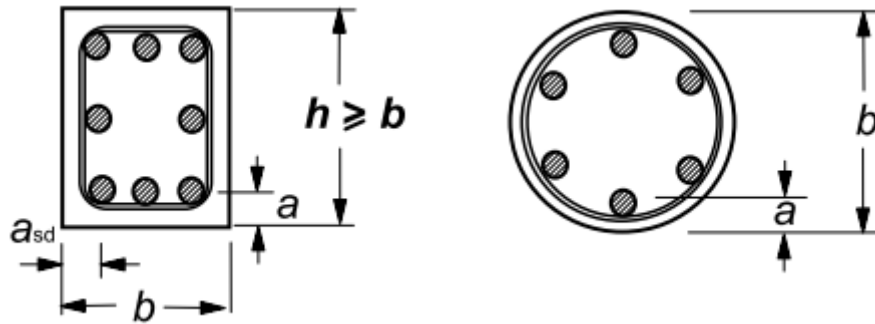

Fig. 6.3.1 Sections through structural members showing nominal axis and minimum dimensions (EN 1992-1-2, Sec-5)

6.3.2. Column 500/52

Tabulated data are given for braced structures.

To assess the fire resistance of columns, two methods (A and B) are provided in EN 1992-1-2, Sec-5. For this study, method B is used. Validity of the method is first checked before using tabulated data:

- o Load level, n_{column} , at normal temperature conditions is :

$$n_{column} = \frac{N_{0Ed,fi}}{0,7 \times (A_c f_{cd} + A_s f_{yd})} \quad (6.13)$$

- o First order eccentricity under fire conditions, e , is :

$$e = \frac{M_{0Ed,fi}}{N_{0Ed,fi}} \quad (6.14)$$

Under the condition $e/b \leq 0,25$ ($e = 0,004$).

- o Slenderness of the column under fire conditions λ_{fi} as mentioned in EN 1992-1-2, Sec-5, Note 2, is assumed to be equal to λ at normal temperature in all cases.
- o The mechanical reinforcement ratio at normal temperature is:

$$\omega = \frac{A_s f_{yd}}{A_c f_{cd}} \quad (6.15)$$

All of those parameters are sum up in Table 6.3.1.

Table 6.3.1 Parameters for method B (Tabulated data) – column B2

n	e	λ_{fi}	ω
0,61	0,004	22,5	0,33

According to Figure 6.3.2, by linear interpolation between the different column tables the minimum dimensions required for $\omega = 0,33$ and $n=0,61$ are 500/46. Therefore the column fire resistance is R90.

Standard fire resistance	Mechanical reinforcement ratio ω	Minimum dimensions (mm). Column width b_{min} /axis distance a			
		$n = 0,15$	$n = 0,3$	$n = 0,5$	$n = 0,7$
1	2	3	4	5	6
R 30	0,100	150/25*	150/25*	200/30:250/25*	300/30:350/25*
	0,500	150/25*	150/25*	150/25*	200/30:250/25*
	1,000	150/25*	150/25*	150/25*	200/30:300/25*
R 60	0,100	150/30:200/25*	200/40:300/25*	300/40:500/25*	500/25*
	0,500	150/25*	150/35:200/25*	250/35:350/25*	350/40:550/25*
	1,000	150/25*	150/30:200/25*	200/40:400/25*	300/50:600/30
R 90	0,100	200/40:250/25*	300/40:400/25*	500/50:550/25*	550/40:600/25*
	0,500	150/35:200/25*	200/45:300/25*	300/45:550/25*	500/50:600/40
	1,000	200/25*	200/40:300/25*	250/40:550/25*	500/50:600/45
R 120	0,100	250/50:350/25*	400/50:550/25*	550/25*	550/60:600/45
	0,500	200/45:300/25*	300/45:550/25*	450/50:600/25*	500/60:600/50
	1,000	200/40:250/25*	250/50:400/25*	450/45:600/30	600/60
R 180	0,100	400/50:500/25*	500/60:550/25*	550/60:600/30	(1)
	0,500	300/45:450/25*	450/50:600/25*	500/60:600/50	600/75
	1,000	300/35:400/25*	450/50:550/25*	500/60:600/45	(1)
R 240	0,100	500/60:550/25*	550/40:600/25*	600/75	(1)
	0,500	450/45:500/25*	550/55:600/25*	600/70	(1)
	1,000	400/45:500/25*	500/40:600/30	600/60	(1)

* Normally the cover required by EN 1992-1-1 will control.

(1) Requires width greater than 600 mm. Particular assessment for buckling is required.

Fig. 6.3.2 Fire resistance, minimum column dimensions and axis distances for reinforced concrete columns with rectangular or circular section (EN 1992-1-2, Sec-5)

6.3.3. Beam 250/44

Tabulated data in *En 1992-1-2, Sec-5* apply to beams exposed to fire on three sides. In this building, the upper side is insulated by slabs during the whole fire duration.

The beam has a constant width $b_{w,beam}$ (equals to 0,25 m). Figure 6.3.3 provides minimum values of axis distance to the soffit and sides of continuous beams and minimum widths of the beam, for standard fire resistance from R30 to R240.

The beam has only one layer of reinforcement. Interpolation between columns 2 and 3 gives a width of 250 mm and an axis distance of 40 mm. However, as indicated under the table, for of width values less than values in column 3, an increase of a is required. Then, for R120, a_{sd} is equal to 45 mm (35 + 10 mm).

The continuous beam can ensure its load-bearing capacity up to 90 minutes. For R90 and above, the area of top reinforcement over the intermediate support, for up to a distance of $0,3l_{eff}$ from the center line of the support is sufficient (see *EN 1992-1-2, Sec-5*).

Note: it is assumed that redistribution of bending moment under normal temperature design does not exceed 15 %. Otherwise, the continuous beam should be considered as simply supported.

Standard fire resistance	Minimum dimensions (mm)						
	Possible combinations of a and b_{min} where a is the average axis distance and b_{min} is the width of beam				Web thickness b_w		
					Class WA	Class WB	Class WC
1	2	3	4	5	6	7	8
R 30	$b_{min} = 80$ $a = 15^*$	160 12*			80	80	80
R 60	$b_{min} = 120$ $a = 25$	200 12*			100	80	100
R 90	$b_{min} = 150$ $a = 35$	250 25			110	100	100
R 120	$b_{min} = 200$ $a = 45$	300 35	450 35	500 30	130	120	120
R 180	$b_{min} = 240$ $a = 60$	400 50	550 50	600 40	150	150	140
R 240	$b_{min} = 280$ $a = 75$	500 60	650 60	700 50	170	170	160
$a_{sd} = a + 10\text{mm}$ (see note below)							
For prestressed beams the increase of axis distance according to 5.2(5) should be noted.							
a_{sd} is the axis distance to the side of beam for the corner bars (or tendon or wire) of beams with only one layer of reinforcement. For values of b_{min} greater than that given in Column 3 no increase of a_{sd} is required.							
* Normally the cover required by EN 1992-1-1 will control.							

Fig. 6.3.3 Minimum dimensions and axis distances - continuous reinforced concrete beam (EN 1992-1-2, Sec-5)

6.3.4. Slab 180/36/49

Fire resistance of reinforced concrete slabs is considered adequate if the values of Figure 6.3.4 are applied. The minimum slab thickness h_s ensures adequate separating function (criteria E and I).

In this building, continuous solid two-way-slabs are supported at all four edges. The values given in Figure 6.3.4 (column 2 and 4) apply to one-way or two-way continuous slab.

The ratio of the lengths in y and x-directions l_y/l_x is equal to 1,32 < 1,5. Columns 2 and 4 of Figure 6.3.4 apply.

Note: moment redistribution is assumed not to exceed 15 % for ambient temperature design.

Standard fire resistance	Minimum dimensions (mm)			
	slab thickness h_s (mm)	axis-distance a		
		one way	two way:	
		$l_y/l_x \leq 1,5$	$1,5 < l_y/l_x \leq 2$	
1	2	3	4	5
REI 30	60	10*	10*	10*
REI 60	80	20	10*	15*
REI 90	100	30	15*	20
REI 120	120	40	20	25
REI 180	150	55	30	40
REI 240	175	65	40	50

l_x and l_y are the spans of a two-way slab (two directions at right angles) where l_y is the longer span.

For prestressed slabs the increase of axis distance according to 5.2(5) should be noted.

The axis distance a in Column 4 and 5 for two way slabs relate to slabs supported at all four edges. Otherwise, they should be treated as one-way spanning slab.

* Normally the cover required by EN 1992-1-1 will control.

Fig. 6.3.4 Minimum dimensions and axis distance for reinforced concrete simply supported one-way and two-way solid slabs (EN 1992-1-2, Sec-5)

The French National Annex gives additional rules on rotation capacity on supports. In case of continuous slab, if the condition related to the slab thickness is verified (see Eqn 6.16), the calculation under fire may be avoided provided the axis distance of column 5 of Figure 6.3.4 is used.

The continuous slab can maintain its load-bearing capacity up to 180 minutes. For 240 minutes, the minimum axis distance of the reinforcement in X-direction (36 mm) is less than the one in the table (40 mm). In y-direction, if we use the French National Annex, column 5 may be used leading to an axis distance of 50 mm (> 49 mm).

The French National Annex requires on supports, under ambient temperature, reinforcement at least equal to 50 % of the isostatic bending moment, over a length at least equal to 1/3 of the longest contiguous span.

The condition for the thickness of the slab is:

$$h > -h_0 + \frac{b_0}{\frac{100\Omega_R}{L} - a_0} \quad (6.16)$$

Limiting values for angle Ω of the yield hinge (Ω_R) are based on reinforcement properties:

- $\Omega_R = 0,25$ for class A (bars and rods)
- $\Omega_R = 0,25$ for class B (bars and rods)
- $\Omega_R = 0,08$ for Wire Fabrics

L is the half the sum of the two ideal spans located west and east of the support. In Y-direction, L equals to 7,125 m and in X-direction, L equals to 5,40 m. Coefficients a_0 , b_0 and h_0 are in Table 6.3.2.

Table 6.3.2 Coefficients a_0 , b_0 et h_0

REI	a_0	b_0	h_0
30	-1,81	0,882	0,0564
60	-2,67	1,289	0,0715
90	-3,64	1,868	0,1082
120	-5,28	3,097	0,1860
180	-40,20	105,740	2,2240

The numerical application leads to the height for different duration of fire in Table 6.3.3 ($\Omega_R = 0,25$).

Table 6.3.3 Minimum height h of the slab ($\Omega_R = 0,25$)

$\Omega_R = 0,25$	$L=7,125$ m (in Y-direction)	$L=5,40$ m (in X-direction)
30 min	0,109 m	0,081 m
60 min	0,137 m	0,105 m
90 min	0,153 m	0,118 m
120 min	0,166 m	0,127 m
180 min	0,195 m	0,135 m

From table 6.3.3 the slab maintains its load-bearing capacity up to 120 minutes, for 180 minutes the condition is not verified ($0,195 \text{ m} > h_{slab}$).

6.3.5. Summary

Resistance to fire R calculated with tabulated data are in Table 6.3.4.

Table 6.3.4 Duration of load bearing capacity of members with tabulated data

Method	Column	Beam	Slab
Tabulated data	R90	R90	R120

6.4 Simplified calculation methods

6.4.1. Methodology

In this part, the member is considered as isolated. Indirect fire actions are not considered, except those resulting from thermal gradients.

Simplified calculation methods are used to determine the ultimate load-bearing capacity of a heated cross-section under the relevant combination of actions. In the fire situation it has to be verified that the design effect of actions $E_{d,fi}$ is less than or equal to the corresponding design resistance $R_{d,t,fi}$.

Temperatures profiles in concrete cross-sections subjected to a fire standard exposure are calculated using software *Cim'Feu EC2* developed in France and concrete thermal properties (see 6.2.3).

In EN 1992-1-2, Sec-4 and in EN 1992-1-2, Annex B, three simplified methods are described:

- **'500°C isotherm method'**: this method is applicable to a standard fire exposure and any other heat regimes which cause similar temperature fields in the fire exposed member. The method is valid for minimum width of cross-section depending on the fire resistance or on the fire load density (see EN 1992-1-2, Annex B, Table B1). The thickness of the damaged concrete a_{500} is assumed equal to the average depth of the 500°C isotherm in the compression zone of the cross-section. Concrete with temperatures in excess of 500°C is assumed not to contribute to the member load bearing capacity, while the residual concrete cross-section retains its initial values of strength and modulus of elasticity.
- **'Zone method'**: this method provides more accurate results than the previous one, especially for columns but is applicable to the standard temperature-time curve only. The fire damaged cross-section is represented by a reduced cross-section ignoring a damaged zone of thickness a_z at the fire exposed sides.
- The **method based on estimation of curvature** deals with columns where second order effects under fire are significant, assessing a reinforced concrete cross-section exposed to bending moment and axial load. This method is based on the estimation of the curvature (EN 1992-1-1, Sec-5).

6.4.2. Column

In this study, the structural behaviour of the column is significantly influenced by second order effects under fire conditions. The damage of the outer layers of the column due to high temperatures, combined with the drop of the elasticity modulus at the inner layers, results in a decrease of the stiffness. Therefore according to EN 1992-1-2, Annex B, a procedure is presented to calculate the load-bearing capacity of a reinforced concrete cross-section subjected to bending moment and axial load using the method based on estimation of curvature, considered as an isolated member under fire conditions. The estimation of curvature is described in EN 1992-1-2, Sec-5.

As a safe simplification the effective length under fire conditions, $l_{0,fi,column}$, may be assumed equal to $l_{0,column}$ at normal temperature ($l_{0,fi,column}$ is equal to 3,1 m, see Chapter 3).

In the first step, using software (CIM'feu EC2) temperature profiles in the concrete cross-section subjected to a standard 180 minutes fire exposure are determined omitting the presence of reinforcement - see Figure 6.4.1. Concrete thermal properties are defined in section 6.2.3.

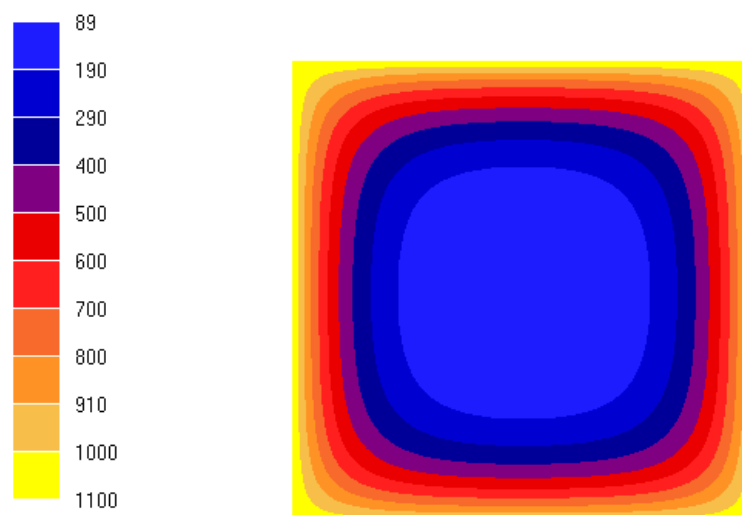

Fig. 6.4.1 Temperature profiles in cross-section of the column

In the second step, the temperatures in the center of the reinforcing bars are determined, see Table 6.4.1. For each reinforcing bar, the reduction coefficient factor $k_s(\theta)$ is calculated.

Table 6.4.1 Temperatures and reduced strength of steel reinforcement

	ϕ (mm)	A_s (mm ²)	x (mm)	y (mm)	T (°C)	$k_s(\theta)$	$A_s k_s(\theta)$ (mm ²)	$k_s(\theta) f_{yd}(\theta)$ (MPa)	$k_s(\theta) f_{yd}(\theta) A_s$ (MN)
1	20	314	52	52	741,4	0,116	36	57.93	0,018
2	20	314	202	52	488,6	0,701	220	350.39	0,110
3	20	314	298	52	488,6	0,701	220	350.39	0,110
4	20	314	448	52	741,4	0,116	36	57.93	0,018
5	20	314	52	202	488,6	0,701	220	350.39	0,110
6	20	314	448	202	488,6	0,701	220	350.39	0,110
7	20	314	52	298	488,6	0,701	220	350.39	0,110
8	20	314	448	298	488,6	0,701	220	350.39	0,110
9	20	314	52	448	741,4	0,116	36	57.93	0,018
10	20	314	202	448	488,6	0,701	220	350.39	0,110
11	20	314	298	448	488,6	0,701	220	350.39	0,110
12	20	314	448	448	741,4	0,116	36	57.93	0,018
						Σ	1908		0,952

Strength properties of concrete and steel reinforcement under fire conditions are:

- Concrete: $f_{cd,fi,column}(20^\circ C) = 30/1=30$ MPa
- Steel reinforcement: $f_{yd,fi,column}(20^\circ C) = 500/1=500$ MPa

Table 6.4.1 indicates that $A_s f_{yd,fi}(\theta)$ is equal to 0,952 MN. According to EN 1992-1-2, Annex B, the thickness of the damaged concrete, $a_{500,column}$, is equal to 60 mm for an exposure of 180 minutes and a width of 500 mm. So, $A_c f_{cd,fi}(\theta)$ is equal to 4,33 MN (Table 6.4.2).

Table 6.4.2 Damaged zone az according to EN 1992-1-2, Annex B

Time of exposure	a_z (mm)	$A_{c,fi}$ (cm ²)	$A_{c,fi} f_{cd,fi}$ (MN)
R90	40,6	1754	5,26
R120	49,8	1603	4,81
R180	60	1444	4,33

As mentioned in section 2.5, the axial normal force $N_{Ed,fi,column} = 2,849$ MN and the bending moment $M_{Ed,fi,column} = 14$ kNm.

The first order eccentricity $e_{0,column}$ is equal to 0,033 m taken into account additional eccentricity (effect of imperfections, see EN 1992-1-2, Sec-5 and chapter 3). The first order bending moment for fire conditions $M_{0Ed,fi,column}$ is 108 kNm.

The moment-curvature diagram for the axial normal force $N_{Ed,fi,column}$ is determined for each reinforcing bar and for each concrete zone using the relevant stress-strain diagram (see Figure 6.4.2). The resistant moment is calculated for different curvatures and the ultimate moment $M_{Rd,fi,column}$ is determined. Calculations lead to an ultimate moment $M_{Rd,fi,column} = 246$ kNm with a curvature $(1/r)_{fi,column}$ equals to 0,035 m⁻¹.

The nominal second order moment $M_{2,fi,column}$ for the curvature corresponding to the maximum moment $M_{Rd,fi,column,max}$ is determined, as follow (see EN 1992-1-1, Sec-5):

$$M_{2,fi} = N_{Ed,fi} (1/r)^2 / c = 2849 \cdot 0,035 \cdot 3,1^2 / \pi^2 = 96 \text{ kNm} \quad (6.17)$$

Where c is a factor depending on the curvature distribution (c equals to π^2). For $(1/r)_{fi,column}$ equals to $0,035 \text{ m}^{-1}$ and $N_{Ed,fi,column}$ equals to 2849 kN, $M_{2,fi,column}$ is equal to 96 kNm.

The remaining ultimate first order moment capacity $M_{0Rd,fi,column,max}$ is then calculated as the difference between the ultimate moment capacity and the nominal second order moment (Figure 6.4.2), as follow:

$$M_{0Rd,fi,column} = M_{Rd,fi,column} - N_{Ed,fi} (1/r)_0^2 / c = 246 - 96 = 150 \text{ kNm} \quad (6.18)$$

$M_{0Rd,fi,column}$ is equal to 150 kNm.

Comparing in the final step the remaining ultimate first order moment capacity $M_{0Rd,fi,column}$ with the first order bending moment for fire conditions $M_{0Ed,fi,column}$:

$$M_{0Rd,fi,column} = 150 \text{ kNm} > M_{0Ed,fi,column} = 108 \text{ kNm} \quad (6.19)$$

All results are summed up in Table 6.4.3.

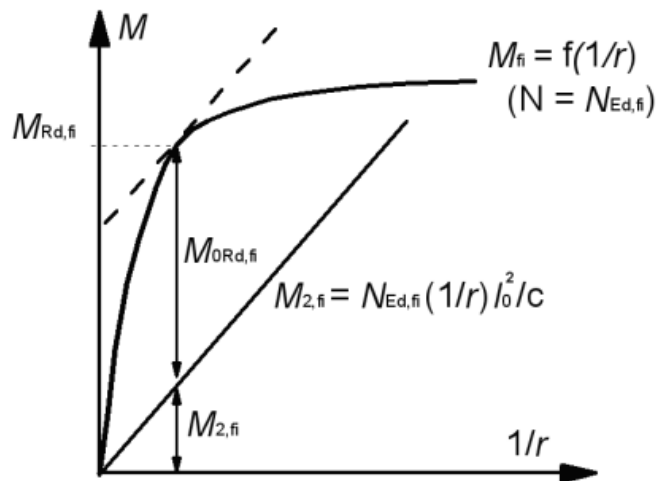

Fig. 6.4.2 Ultimate moment capacity, second order moment and ultimate first order moment capacity as a function of the curvature ($1/r$) (EN 1992-1-2, Annex B)

Table 6.4.3 Calculation results for column under fire conditions at 180 minutes

$M_{Rd,fi,column}$	$M_{0Rd,fi,column}$	$M_{2,fi,column}$	$M_{0Ed,fi,column}$	$N_{0Ed,fi,column}$	$(1/r)_{fi,column}$
246 kNm	150 kNm	96 kNm	108 kNm	2849 kN	$0,035 \text{ m}^{-1}$

The column load-bearing capacity under fire is R = 180 minutes.

6.4.3. Continuous beam

Calculations are made at mid-span, internal and end supports on the basis of the design moments (section 6.2.5), geometry of the beam (section 6.2.4) and the reinforcing bars sections and cover (section 6.2.5).

6.4.3.1 Mid-span

In a first step, temperatures profiles in the concrete cross-section subjected to a 120 minutes standard fire exposure are determined omitting the presence of reinforcement, with software (*CIM'feu EC2*), see Figure 6.4.3. Concrete thermal properties are presented in section 6.2.3.

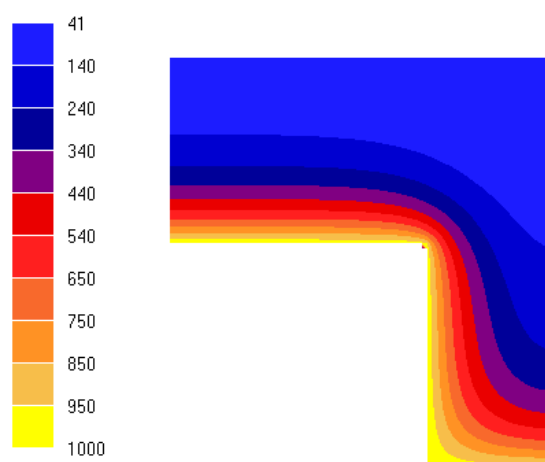

Fig. 6.4.3 Temperatures profiles in the beam

Temperatures in steel reinforcement are presented with the corresponding strength reduction factor, are in Table 6.4.4, for 120 minutes of fire exposure.

Table 6.4.4 Temperatures reduced sections and tension under 120 minutes of fire exposure mid-span of the continuous beam in axis 2

Layer	Steel	A_s (cm ²)	T (°C)	k_s	$k_s A_s$ (cm ²)	F_s (kN)
1	1 ϕ 16	2,01	507	0,65	1,31	65,5
1	2 ϕ 16	4,02	677	0,18	0,72	36
Σ	3 ϕ 16	6,03	-	-	2,03	101,5

The total tension force in steel reinforcement under fire at 120 minutes is $F_{s,fi,mid-span,beam} = 101,5$ kN. The effective depth $d_{mid-span,beam}$ is 356 mm. Equilibrium of forces leads to an effective height of the compressive zone equal to 8,82 mm. The lever arm $z_{mid-span,beam}$ of the internal forces is 352 mm. The resistant moment of the section at mid-span under fire is $M_{Rd,fi,mid-span,beam} = 36$ kNm.

6.4.3.2 Internal support

The total tension force in steel reinforcement under fire at 120 minutes is $F_{s,fi,intermediate,beam} = 508,5$ kN. As mentioned before, EN 1992-1-2, Sec-4 allows simplified calculation methods to determine the ultimate load-bearing capacity of a heated cross section and to compare the capacity with the relevant combination of actions. In this case, the '500°C isotherm method may be used because the fire exposure is a standard one and the cross-section has a width $b_w = 250$ mm greater than 160 mm at 120 minutes. This method gives a reduction of the cross-section size assuming a heat damaged zone at the concrete surfaces. Damaged concrete, i.e. concrete with temperatures in excess of 500°C, is

assumed not to contribute to the load bearing capacity of the member, while the residual concrete cross-section retains its initial values of strength and modulus of elasticity.

The procedure for calculating the resistance of the cross-section at intermediate support of the beam in the fire condition is as follows:

- The isotherm of 500°C for the standard fire exposure is determined according to temperature profiles in the cross-section;
- The resulting width $b_{w,fi}$ and an effective height d_{fi} of the cross-section are determined excluding the concrete outside the 500 °C isotherm (Figure 6.4.4): $b_{w,fi} = 160$ mm and $d_{fi} = 278$ mm;

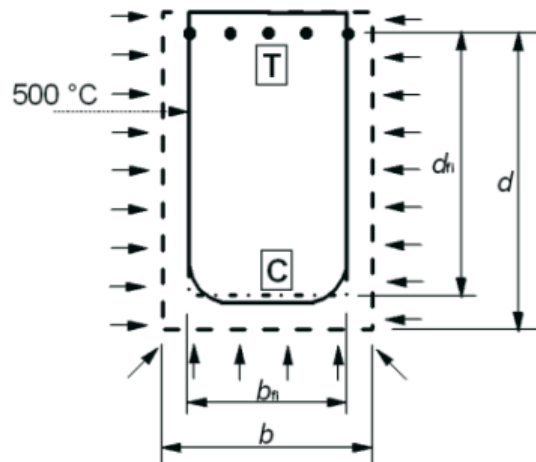

C — Compression

Fig. 6.4.4 Fire exposure on three sides, reduced cross-section of a reinforced concrete beam at support (EN 1992-1-2, Annex B)

- The temperature of reinforcing bars in tension and their reduced strength are determined (see table 6.4.5).

Table 6.4.5 Temperatures, reduced sections and tension under 120 minutes of fire exposure at intermediate support of the continuous beam in axis 2

Layer	Steel	A_s (cm ²)	T (°C)	k_s	$k_s A_s$ (cm ²)	F_s (kN)
1	1φ12	1,13	50	1	1,13	56,5
1	2φ12	2,26	93	1	2,26	113
1	2φ12	2,26	99,5	1	2,26	113
1	2φ12	2,26	99,5	1	2,26	113
1	2φ12	2,26	99,5	1	2,26	113
Σ	9φ12	10,17	-	-	10,17	508,5

The total tension force in reinforcement under fire at 120 minutes is $F_{s,fi,intermediate\ support,beam} = 508,5$ kN.

- The ultimate load-bearing capacity is then calculated

The lever arm $z_{intermediate,beam}$ between the tension reinforcement and concrete is 256 mm. The resisting moment of the section at intermediate support under fire $M_{Rd,fi,intermediate,beam} = 130$ kNm.

6.4.3.3 End support

The procedure for calculating the resistance of the cross-section at end support of the beam in the fire condition is the same as for the intermediate support:

- The isotherm of 500°C for the standard fire exposure is first determined;
- The new width $b_{w,fi}$ and a new effective height d_{fi} of the cross-section is determined excluding the concrete outside the 500 °C isotherm: $b_{w,fi} = 160$ mm and $d_{fi} = 278$ mm;
- The temperature of reinforcing bars in tension and their reduced strength are determined (see Table 6.4.6).

Table 6.4.6 Temperatures, reduced sections and tension under 120 minutes of fire exposure end support of the continuous beam in axis 2

Layer	Steel	A_s (cm ²)	T (°C)	k_s	$k_s A_s$ (cm ²)	F_s (kN)
1	1 ϕ 12	1,13	50	1	1,13	0,057
1	2 ϕ 12	2,26	73,5	1	2,26	0,113
1	2 ϕ 12	2,26	82	1	2,26	0,113
1	2 ϕ 12	2,26	82	1	2,26	0,113
Σ	7 ϕ 12	7,92	-	-	-	0,396

The total tension force in reinforcement under fire at 120 minutes is $F_{s,fi,intermediate\ support,beam} = 396$ kN. The lever arm $z_{end,beam}$ between the tension reinforcement and concrete is 256 mm. The resisting moment of the section at end support under fire is $M_{Rd,fi,end,beam} = 101$ kNm.

6.4.3.4 Summary

The resisting moments $M_{Rd,fi,beam}$ of the continuous beam are presented in Table 6.4.7.

Table 6.4.7 Resisting and design moments for the beam in axis 2 (in kNm)

$M_{Rd,fi,mid-span,beam}$	$M_{Rd,fi,intermediate-support,beam}$	$M_{Rd,fi,end-support,beam}$	$M_{Rd,fi,beam}$	$M_{0Ed,fi,beam}$
36	130	101	151,50	128,7

The total resistant moment $M_{Rd,fi,beam}$ is then compared with the isostatic moment of the corresponding beam to verify if $M_{0Ed,fi,beam}$: $M_{Rd,fi,beam} > M_{0Ed,fi,beam}$.

The total resistant moment of the beam is $M_{Rd,fi,beam} = 151,50$ kNm $>$ $M_{0Ed,fi,beam} 128,7$ kNm.

The beam load-bearing capacity under fire is R = 120 minutes.

6.4.4. Two-way slab

Calculations have been made in the two directions of the slab (x and y-), according to design moments (see Table 6.2.8 and Table 6.2.9), geometry of the slab (see section 6.2) and the reinforcing bars (sections and cover, see Table 6.2.6 and Table 6.2.7).

In a first step, temperatures profiles in the concrete cross-section subjected to a fire exposure at 180 minutes have been determined omitting the presence of reinforcement with software (*CIM'feu EC2*), see Figure 6.4.5. Thermal properties of the concrete are in section 6.2. Tables 6.4.8 and 6.4.9 present temperatures in the center of the reinforcing bars with the associated strength reduction factor $k_s(\theta)$ for the two directions.

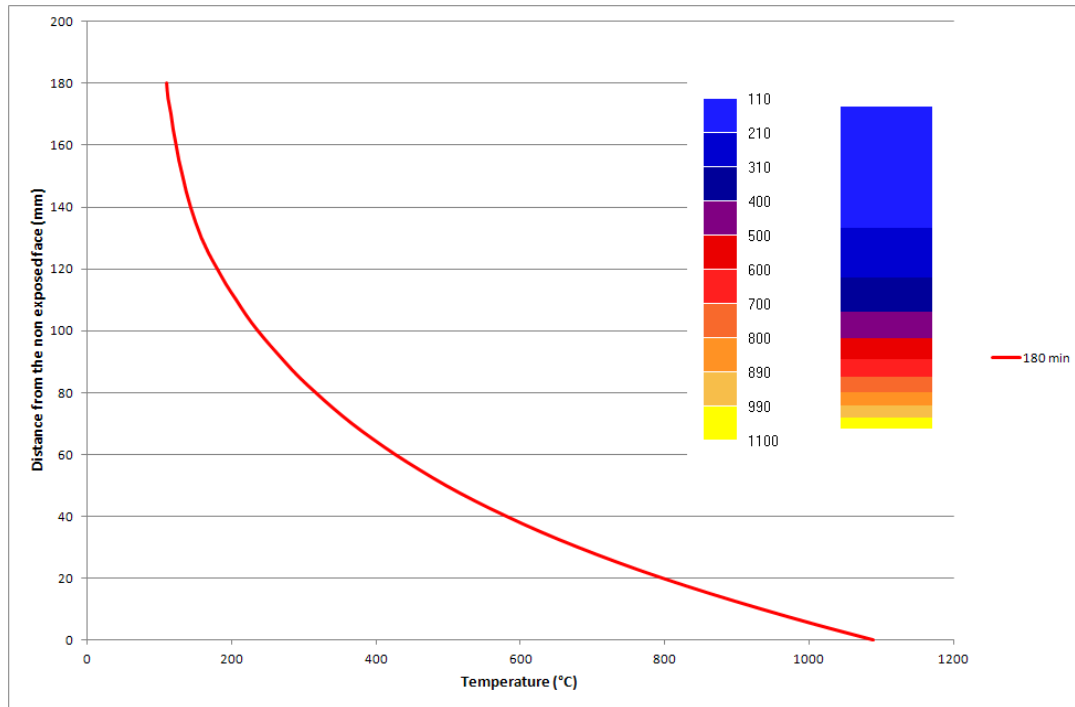

Fig. 6.4.5 Temperatures profiles in slab

Table 6.4.8 Temperatures, reduced sections and tension under 180 minutes of fire exposure mid-span and support of the continuous slab (X-direction)

	Steel	A_s (cm ²)	T (°C)	$k_s(\theta)$	$k_s A_s$ (cm ²)	F_s (kN)
At mid-span	8φ12	9,05	619	0,3468	3,14	157
At support	4φ14	6,16	140,4	1	6,16	308

Table 6.4.9 Temperatures, reduced sections and tension under 180 minutes of fire exposure mid-span and support of the continuous slab (Y-direction)

	Steel	A_s (cm ²)	T (°C)	k_s	$k_s A_s$ (cm ²)	F_s (kN)
At mid-span	4φ12+4φ14	10,68	497	0,68	7,24	362
At support	4φ16	8,04	164	1	8,04	402

Calculations are done successively for the two directions:

- In X-direction

At mid-span, the total tension force in reinforcement after 180 minutes fire is $F_{s,fi,mid-span,x-slab} = 157$ kN. The effective depth $d_{mid-span,x-slab}$ is 144 mm. the effective height of the compressive zone is 1,3 mm. The lever arm $z_{mid-span,slab}$ of the internal forces is 143,3 mm. The resisting moment of the section at mid-span under fire is $M_{Rd,fi,mid-span,x-slab} = 22,50$ kNm/m. At support, calculations give a resisting moment under fire $M_{Rd,fi,support,x-slab} = 36$ kNm/m.

The total resistant moment is $M_{Rd,fi,x-slab} = 36 + 22,5 = 58,50$ kNm/m. The design moment in X-direction for the two-way slab is $M_{Ed,fi,x-slab} = 15,9$ kN.m/m. The load-bearing capacity of the slab in the X-direction is verified at 180 minutes.

- In Y-direction

At mid-span, the total tension force in reinforcement after 180 minutes fire is $F_{s,fi,mid-span,y-slab} = 362$ kN. The effective depth $d_{mid-span,y-slab}$ is 131 mm, the effective height of the compressive zone is 14,6 mm. The lever arm $z_{mid-span,y-slab}$ of the internal forces is 122 mm. The resisting moment of the section at

mid-span under fire is $M_{Rd,fi,mid-span,y-slab} = 44,14$ kNm/m. At support, calculations lead to a resisting moment under fire $M_{Rd,fi,support,y-slab} = 39,70$ kN.m/m. The total resistant moment is $M_{Rd,fi,y-slab} = 44,14+39,70 = 83,84$ kNm/m. The design moment in Y-direction for the two-way slab is $M_{Ed,fi,y-slab} = 10,7$ kN.m/m. The load-bearing capacity of the slab in the Y-direction is verified at 180 minutes.

All results (X and Y direction) are presented in Table 6.4.10.

Table 6.4.10 Two-way slab - resisting and design moments (kNm/m)

$M_{Rd,fi,x-slab}$	$M_{Ed,fi,x-slab}$	$M_{Rd,fi,y-slab}$	$M_{Ed,fi,y-slab}$
58,50	15,9	83,84	10,7

The load-bearing capacity of the two-way slab under fire is R = 180 minutes.

6.5 Advanced calculation methods

Advanced calculation methods, based on fundamental physical behaviour, are based on a “global” structural analysis (analysis of the entire structure) for the fire situation and provide a realistic analysis of structures exposed to fire. Indirect fire actions are considered throughout the structure. In global structural analysis the relevant failure mode in fire exposure, the temperature-dependent material properties and member stiffnesses, effects of thermal expansions and deformations (indirect fire actions) have to be taken into account (*EN 1992-1-2, Sec-2*).

Advanced calculation methods include (*EN 1992-1-2, Sec-4*):

- a thermal response model based on the theory of heat transfer and the thermal actions presented in *EN 1991-1-2*. Any heating curve can be used, provided that the material (concrete and steel) properties are known for the relevant temperature range.
- a mechanical response model taking into account the changes of mechanical properties with temperature. The effects of thermally induced strains and stresses due to temperature and temperature differentials have to be considered. Compatibility must be ensured and maintained between all parts of the structure (limitation of deformations). Geometrical non-linear effects are taken into account. The partition of deformation may be assumed. Special attention is given to boundary conditions.

6.6 Conclusions

For determining the load-bearing capacity of the column, beam and slab, tabulated data and simplified methods have been used. Calculations were based on member analysis. The use of simplified methods results in longer fire resistances R, see Table 6.6.1. In future work, advanced calculation methods should provide a more accurate estimation of the duration of the load-bearing capacity of the entire or of a part of the structure.

Table 6.6.1 Duration of load bearing capacity of members with tabulated data and simplified calculation methods

	Column	Beam	Slab
Tabulated data	R90	R90	R120
Simplified method	R180	R120	R180

References

EN 1990:2003. Eurocode 0: Basis of Structural Design. CEN.

EN 1991-1-1:2003. Eurocode 1 : Actions on structures. Part 1-1: General actions – Densities, self-weight and imposed loads for buildings. CEN.

EN 1991-1-2:2003. Eurocode 1: Actions on structures. Part 1-2: General actions, actions on structures exposed to fire. CEN.

EN 1992-1-1:2005. Eurocode 2: Design of concrete structures. Part 1-1: General rules and rules for buildings. CEN.

EN 1992-1-2:2005. Eurocode 2: Design of concrete structures. Part 1-2: General rules - Structural fire design. CEN.

European Commission

EUR 26566 EN – Joint Research Centre – Institute for the Protection and Security of the Citizen

Title: **Eurocode 2: DESIGN OF CONCRETE BUILDINGS**

Author(s): Francesco Biasioli, Giuseppe Mancini, Martin Just, Manfred Curbach, Just Walraven, Sausanne Gmainer,
Jose Arrieta, Roger Frank, Caroline Morin, Fabienne Robert

Editors: Francesco Biasioli, Martin Poljanšek, Borislava Nikolova, Silvia Dimova, Artur V. Pinto

Luxembourg: Publications Office of the European Union

2014 – 182 pp. – 21.0 x 29.7 cm

EUR – Scientific and Technical Research series – ISSN 1831-9424

ISBN 978-92-79-36548-5

doi:10.2788/35386

Abstract

This document is a report with worked examples presenting step-by-step the design of a reinforced concrete cast on site building following Eurocode 2. The design process has been divided between different authors, some of whom were involved in the preparation and/or assessment of Eurocode 2. Each chapter of the report focuses on a different step in the design process: conceptual design, structural analyses, limit states design and verification, detailing of the reinforcement as well as some geotechnical aspects of building design. Last chapter gives general overview of the fire design according to the Eurocodes.

The materials were prepared and presented at the workshop "Eurocode 2: Design of Concrete Buildings" held on 20-21 October 2011 in Brussels, Belgium. The workshop was organized by JRC with the support of DG ENTR and CEN, and in collaboration with CEN/TC250/Sub-Committee 2.

The document is part of the Report Series 'Support to the implementation, harmonization and further development of the Eurocodes' prepared by JRC in collaboration with DG ENTR and CEN/TC250 "Structural Eurocodes".

As the Commission's in-house science service, the Joint Research Centre's mission is to provide EU policies with independent, evidence-based scientific and technical support throughout the whole policy cycle. Working in close cooperation with policy Directorates-General, the JRC addresses key societal challenges while stimulating innovation through developing new methods, tools and standards, and sharing its know-how with the Member States, the scientific community and international partners.

