

# Technical Disclosure Commons

---

Defensive Publications Series

---

December 2020

## Household appliance

Christian Mohr

Follow this and additional works at: [https://www.tdcommons.org/dpubs\\_series](https://www.tdcommons.org/dpubs_series)

---

### Recommended Citation

Mohr, Christian, "Household appliance", Technical Disclosure Commons, (December 11, 2020)  
[https://www.tdcommons.org/dpubs\\_series/3878](https://www.tdcommons.org/dpubs_series/3878)



This work is licensed under a [Creative Commons Attribution 4.0 License](https://creativecommons.org/licenses/by/4.0/).

This Article is brought to you for free and open access by Technical Disclosure Commons. It has been accepted for inclusion in Defensive Publications Series by an authorized administrator of Technical Disclosure Commons.

**Description**Household appliance and a method for operating the same

The present invention relates to household appliance, particularly a cooking appliance, more particularly a cooking hob, specifically an induction cooking hob, comprising a consumer load and a mains connection unit according to claim 1. The present invention further relates to a method for operating a household appliance according to claim 13.

10 Generally, household appliances are provided for treating or preserving items. They are assembled from modular components, which comprise at least one consumer load, e.g. motors, heating elements, pumps, or the like, for their operation. A relevant number of said modular components is of electrical nature, which  
15 modular components have to be supplied with electrical energy. Some of these consumer loads are operated with high power, what specifically applies to heating elements, particularly in cooking appliances, such as cooking hobs. A common cooking hob is equipped with four cooking zones, wherein a cooking zone of a  
20 cooking hob for domestic use is limited to a maximum power level of 3600 W, due to the limitation of a domestic power supply line to 16 A in order to protect it against overheating. A user of such a cooking hob sometimes wants to operate a cooking zone with an excessive power level, especially for an initial fast  
25 browning of a food item requiring said excessive power level. To this end, cooking hobs with a so-called "boost function" are known, which provides a temporarily limited excessive power level to one cooking zone. However, for some users such a temporarily limited boost level is not sufficient, particularly as they  
30 are interested in an accelerated cooking function.

It is an object of the present invention to provide a household appliance, which is operable with a power level requiring an excess of the maximum power level provided by domestic power supply line. In addition, a method for operating such a household  
5 appliance shall be provided, too.

The object is achieved by a household appliance comprising a consumer load, a mains connection unit connected or connectable to a power supply system for supplying the household appliance,  
10 particularly the consumer load, with electrical power and an additional power source for supplying the household appliance with electrical power in addition to the power supplied by the power supply system.

15 The household appliance is particularly a cooking appliance, which may be a cooking hob, specifically an induction cooking hob. In the case of a cooking appliance, the consumer load is particularly a heating system comprising at least one heating  
20 element.

The power supply system may be a power supply line, which may be installed in the household, in which the household appliance is operated.

25 The additional power source is particularly a rechargeable power storage means, which may be a battery, battery arrays or another storage device, such as a high-performance capacitor.

The rechargeable power storage means is preferably rechargeable  
30 by the power supply system. The charging process is particularly carried out during a phase, when the household appliance is out of use, and/or during a phase, when the household appliance is operated with an input power lower than the standard maximum

power or rated power of the power supply system, particularly the power supply line.

According to embodiments, the charging process is controlled by a switching means, preferably by a relay, a transistor or any other electric or electronic switch element or switching circuit. Said switching means may be controllable by a main switch of the household appliance and/or by a power sensor or power measuring device monitoring the household appliance.

10

The additional power source may be arranged in the interior of the household appliance. An alternative place of installation for the additional power source is located next to household appliance and the additional power source is connected or connectable in that case to the household appliance, which connection may be realized by a plug connection.

15

The power supply system and the additional power source may be operable alternately, and the two involved power sources, in particular the power supply system, may be operated during its operating times with an exceeding power level, which, due to its clocked operation, on average will not exceed the maximum power level, so that an overheating of the power supply line and/or a triggering of a fuse protecting the power supply line will not take place.

25

An advantageous embodiment of the present invention, however, provides for a household appliance, in which the power supply system and the additional power source are operable concurrently and, in that, the heating power generated by the additional power source is aggregated with the heating power of the simultaneously operated power supply system. The supply of the power sup-

30

ply system is particularly connectable with or increasable by the supply of the additional power source.

5 The additional power source may be connectable during an operating program or program section with a boost function and/or during a permanent operation with increased power request.

A preferred embodiment provides that the heating system is an induction heating system including a power board for supplying at least one induction heating element with electrical power. The power board may comprise a DC input, which is supplied with DC power, and the DC power is an aggregation of the DC power provided by an AC/DC converter connected to the power supply system and the DC power provided by the additional power source.

15 One specific household appliance is characterized by a first heating system, which comprises at least one first heating element and which is supplied by the power supply system, and by a second heating system, which comprises at least one second heating element and which is supplied by the additional power source. The at least one first heating element is particularly of the same or of a different type as the at least one second heating element.

25 The at least one first heating element and/or the at least one second heating element may be adapted to heat with one of the heating types

- induction heating
- resistive heating
- 30 - radiation heating
- any other heating, in particular electrical heating.

Generally an additional power source using an energy carrier different from electricity, e. g. gas, may be considered, howev-

er, a respective supply line for this different energy carrier has to be considered in this case as well.

According to an embodiment, the second heating system comprises  
5 an associated power board for supplying at least one second heating element with electrical power. The associated power board comprises a DC input and the additional power source supplies the associated power board with DC power.

10 The additional power source may be controllable independently from the power supply system. In addition or alternatively, the second heating system or element may be controllable independently from the first heating system or element.

15 The object regarding the method is achieved by a method for operating a household appliance, which consumes electrical power supplied by a power supply system, in particular by a power supply line. Simultaneously, additional electrical power supplied  
20 by an additional power source is consumed as well. The household appliance is particularly a cooking appliance, more particularly a cooking hob, specifically an induction cooking hob.

Preferably, the first heating system provides an item to be  
25 treated with thermal energy during consumption of electrical energy supplied by the power supply system, and a second heating system provides the item to be treated with additional thermal energy during consumption of electrical energy supplied by the additional power source. Said additional thermal energy is particularly provided during an operating program with a boost  
30 function or during an operating program with fast treatment function.

According to a specific embodiment, the power supply system charges a rechargeable power storage means of the additional power source during a non-operation period of the second heating system and the rechargeable power storage system is discharged during an operation period of the second heating system. The charging is preferably suspended during the operation period of the second heating system.

Novel and inventive features of the present invention are set forth in the appended claims.

The present invention will be described in further detail with reference to the drawing, in which

Fig. 1 illustrates the general structure of an induction cooking hob in an exploded perspective view;

Fig. 2 is a schematic side view in parts of a first example of an induction coil arrangement of the induction cooking hob of Fig. 1;

Fig. 3 schematically illustrates essential components of the structure of an induction cooking hob with additional power source related to the first example according to Fig. 2; and

Fig. 4 is a schematic illustration of a second example of an induction cooking hob with additional power source being an alternative to the first example according to Figs. 2 and 3.

Fig. 1 illustrates an exploded perspective view of the general structure of a cooking hob.

The cooking hob 10 comprises a casing 12 and a panel 14. The casing 12 includes a bottom wall 12a, four sidewalls 12b and an open top side. Preferably, the casing 12 is made of metal, e.g. steel. Alternatively, the casing 12 may be made of plastics. The panel 14 covers the top side of the casing 12. For example, the panel 14 is a glass ceramic panel.

The cooking hob 10 comprises four circular cooking zones 15 with two cooking zones 15 thereof having a smaller diameter, while the diameter of the other two cooking zones 15 are larger. The contours of the cooking zones 15 are indicated by respective circles on the top surface of the glass panel 14. Each cooking zone 15 receives its heating power from a heating element 16 arranged beneath the panel 14.

A carrier 18 supports the heating elements 16. Said carrier 18 is arranged beneath the heating elements 16. The carrier 18 is a metallic plate, preferably made of an aluminium material, and may be of an extension adapted to carry all four heating elements 16, in that having dimensions close to the dimensions of the glass panel 14. Alternatively, four carriers 18 may be provided, each carrier 18 supporting merely one dedicated heating element 16.

The cooking hob 10 further comprises a control panel 20 for controlling the cooking hob functions. The control panel 20 includes touch sensors and display means corresponding with a user interface zone 21 arranged at the front edge of the glass panel 14.

Preferably, the heating element 16 is an electric heating element. At least one printed circuit board 22 is arranged above



the bottom wall 12a of the casing 12. A plurality of electric and/or electronic elements 24, 26 is attached on the printed circuit board 22. The printed circuit board 22 including the electric and/or electronic elements 24, 26 forms a power board  
5 of the cooking hob 10. Power electronic elements 26 for supplying the heating elements 16 with electrical power are attached to a cooling channel 28, which extends horizontally through the cooking hob 10. An air stream driven by at least one fan 30 passes the cooling channel 28 and cools down the power electron-  
10 ic elements 26.

In this example, the cooking hob 10 is an induction cooking hob, wherein the heating element 16 is a heating coil unit 16 comprising an arrangement of induction coils 32 and the carrier 18  
15 is a coil carrier.

According to Fig. 2, which shows a schematic side view in parts of a heating coil unit 16 of the induction cooking hob 10 including the coil carrier 18, an optionally implemented first  
20 discoid layer 34 (not shown in Fig. 1) is arranged between the induction coil arrangement 32 acting as a spacer between the induction coil 28 and the coil carrier 18. This first layer 34 may work also as a support means for the induction coil arrangement  
32.

25 Fig. 2 further shows a second layer 36 (not shown in Fig. 1), which is also optional and which may be arranged directly beneath the panel 14, but above the heating coil unit 16, in that separating the heating coil unit 16 from the glass panel 14. The  
30 second layer 36 provides for electrical isolation of conducting parts of the heating coil unit 16 towards panel 14. In case of the panel 14 being a glass ceramic panel, the isolating effect of such material is more and more decreasing when heated up to a

temperature of more than about 400 centigrades. Then the second layer 36 more and more takes over the electrical isolation, and fully taking over when the glass ceramic temperature is exceeding 700 centigrades. In addition, the second layer 36 may work  
5 as an additional safety element against electric shocks in case of damages to the panel 14.

In Figs. 1 and 2 an additional component in comparison to a conventional induction cooking hob is shown, which is a battery  
10 pack 38 comprising a plurality of battery cells 40. Said battery pack 38 forms an electrical power storage unit and provides an additional power source for the generation of heating power for a cooking zone 15. It is characterized by a flat construction height, in order to increase the total height of the induction  
15 cooking hob 10 only marginally, and it is fixed to the bottom side of the bottom wall 12a.

According to the illustration of the induction coils arrangement 32 in Fig. 2, this arrangement is not a single coil, but an arrangement of a first induction coil 32a and a second induction  
20 coil 32b. Both first 32a and second 32b induction coils are of spiral shape, which are arranged in the same plane, with the second induction coil 32b being incorporated in the first induction coil, however, the second induction coil 32b having a lower  
25 number of turns than the first induction coil 32a. This results in a turns ratio of 2:1, i. e. one pair of turns of the first induction coil 32a is surrounded by two single turns of the second induction coil 32b. Of course, any other turns ratio may be implemented, e. g. 3:1 or 5:2. As will be more explained further  
30 down below with reference to Fig. 3, the second induction coil 32a is electrically connected to and supplied by the battery pack 38.

Fig. 3 schematically indicates by way of a diagrammatic illustration the structure of an induction cooking hob 10 with additional power source 38 of the first example according to Fig. 2 showing also the coaction between essential components. Principally because of a clearer presentation, the incorporation of the second induction coil 32b inside of the first induction coil 32a is shown in Fig. 3 as an arrangement of concentric coils contrary to the formation in Fig. 2, however, the first example of the induction cooking hob 10 described here also works with the arrangement according to Fig. 3 transferred to a real construction. As shown in Fig. 3, a cooking zone 15 of the induction cooking hob 10 has a twofold supply by a first and a second heating system. The first heating system is a conventional one and includes a supply of the first induction coil 32a, which in a conventional induction cooking hob is the only one coil, by a main power supply system comprising a mains terminal unit, indicated in Fig. 3 by the plug 42, and the power board 22 providing the first induction coil 32a with current for an establishment of an electromagnetic field.

Said conventional first heating system is characterized by a maximum power supply, which is limited by a provision of a maximum current of the power supply line the first induction coil 32a being connected to, which power supply line is usually protected by a 16 amp fuse. In order to provide a user of the induction cooking hob 10 with a cooking zone 15 with a heating power exceeding the heating power provided by the first heating system with the first induction coil 32a, a second heating system is provided, which includes a supply of the second induction coil 32b by an additional power board 44, which itself is supplied with electrical power by the battery pack 38. If the user wants to run a fast cooking program, he can operate the induction cooking hob 10 by not only running the first induction coil

32a with maximum power, but also by additionally activating the additional power board 44, so that the second induction coil 32b delivers additional heating power to the cooking zone 15.

5 That way, the cooking zone 15 is heated by the first and the second induction coils in parallel, so that excessive heating power for a fast cooking process is provided.

10 It should be mentioned that, alternatively to the second induction heating coil 32b, other heating units may be included. For example, the second heating unit may be an electric resistance heater, a halogen heater or a radiant heater. In that case, the respective heating element may be supplied by DC current and the related "power board" may just be a circuit including a power  
15 switch and control elements controlling the switching state of said power switch resulting in an operation or non-operation, respectively, of the additional heating system.

20 A proper operation of the additional heating system is not least dependent on a relevant charge level of the rechargeable battery pack 38. Therefore, after discharging the battery pack 38 partially or completely, it has to be recharged. The charging current is also provided by the main power supply system, particularly by the mains terminal unit 42, which, as a result, fulfils  
25 a double function. Its first function is the supply of the first heating system, particularly the first induction coil 32a, and its second function is to charge the battery pack 38. However, in order not to overload the power supply line, the first and second functions do not take place at the same time, at least  
30 not when the first induction coil 32a is supplied with maximum power. In fact, the charging process is carried out during down-times of the first heating system, particularly when no cooking process is running. Additionally or alternatively, a charging

process may be carried out when the cooking zone 15 only requires low power, e. g. during cooking on a low cooking level. The charging process is activated and deactivated by switching charging switch 46 on or off.

5

Fig. 4 is a second example for an induction cooking hob 10 with a cooking zone 15 configured for fast cooking. Contrary to the first example, the cooking zone 15 is heated by only one single induction coil 32c, which, however, is configured to be operated with excessive power for delivering heating power for a fast cooking process. Essentially, both the main power supply system and the electrical power storage unit are connected to the single power board 48, notably to a first and a second input of the single power board 48, which processes the supply of electrical power of solely the mains terminal unit 42 during a normal cooking program, or additionally also the supply of additional electrical power provided by the electrical power storage unit, i. e. by the battery pack 38. As a result, the single induction coil 32c is provided with excessive electrical power, due to the supply of the single power board 48 with an increased DC power, which is an aggregation of the electrical power supplied by the mains terminal unit 42 and of the additional electrical power supplied by the battery pack 38. In order to provide the single power board 48 with DC input, an upstream AC/DC converter 50 is connected to the related input thereof.

Also the second example is characterized by the need of charging the battery pack 38 after a partial or complete discharge. The related charging process is executed similar to that one of the first example.

30

**List of reference numerals**

10	cooking hob
12	casing
12a	bottom wall
12b	side walls
14	glass panel
15	cooking zones
16	heating coil units
18	coil carrier
20	control panel
21	user interface zone
22	power board
24, 26	electric / electronic elements
28	cooling channel
30	fan
32	induction coil arrangement
32a	first induction coil
32b	second induction coil
32c	single induction coil
34, 36	first and second layers
38	battery pack
40	battery cells
42	plug / mains terminal unit
44	additional power board
46	charging switch
48	single power board
50	AC/DC converter

**Claims**

1. A household appliance (10), particularly a cooking appliance, more particularly a cooking hob, specifically an induction cooking hob, comprising
- 5 - a consumer load, particularly a heating system comprising at least one heating element (32),
- a mains connection unit (42) connected or connectable to a power supply system, in particular a power supply line, for supplying the household appliance (10), particularly
- 10 the consumer load (32), with electrical power, and
- an additional power source (38) for supplying the household appliance (10) with power in addition to the power supplied by the power supply system.
- 15 2. The household appliance (10) according to claim 1, characterized in that the additional power source (38) is a rechargeable power storage means, in particular a battery, battery arrays or another storage device, such as a high-performance capacitor.
- 20 3. The household appliance (10) according to claim 2, characterized in that the rechargeable power storage means (38) is rechargeable by the power supply system, in particular during a phase of the household appliance (10) being out of use and/or during a
- 25 phase of the household appliance (10) being operated with an input power lower than the standard maximum power of the power supply system.
- 30 4. The household appliance (10) according to claim 3, characterized in that

the charging process is controlled by a switching means (46), preferably by a relay, a transistor or any other electric or electronic switch element or switching circuit, the switching means (46) particularly being controllable by a main switch  
5 of the household appliance (10) and/or by a power sensor or power measuring device monitoring the household appliance (10).

5. The household appliance (10) according to anyone of the pre-  
10 ceding claims,  
characterized in that  
the additional power source (38) is arranged in the interior of the household appliance (10) or arrangeable next to and connected or connectable, particularly by plug connection, to  
15 the household appliance (10).

6. The household appliance (10) according to anyone of the pre-  
ceding claims,  
characterized in that  
20 the power supply system and the additional power source (38) are operable alternately or concurrently, wherein the supply of the power supply system is particularly connectable with or increasable by the supply of the additional power source.

25 7. The household appliance (10) according to claim 6,  
characterized in that  
the additional power source (38) is connectable during an operating program or program section with boost function and/or  
30 during a permanent operation with increased power request.

8. The household appliance (10) according to anyone of the pre-  
ceding claims,



characterized in that

the heating system is an induction heating system including a power board (48) for supplying at least one induction heating element (32c) with electrical power, wherein the power board  
5 (48) comprises a DC input, which is supplied with DC power, the DC power being an aggregation of the DC power provided by an AC/DC converter connected to the power supply system and the DC power provided by the additional power source (38).

10 9. The household appliance (10) according to anyone of the claims 1 to 7,

characterized by

a first heating system comprising at least one first heating element (32a) supplied by the power supply system and a second heating system comprising at least one second heating element (32b) supplied by the additional power source (38), the  
15 at least one first heating element (32a) particularly being of the same or of a different type as the at least one second heating element (32b).

20

10. The household appliance (10) according to claim 9,

characterized in that

the at least one first heating element (32a) and/or the at least one second heating element (32b) is adapted to heat  
25 with one of the heating types

- induction heating
- resistive heating
- radiation heating
- any other heating, in particular electrical heating.

30

11. The household appliance (10) according to claim 9 or 10, characterized in that

the second heating system comprises an associated power board (44) with a DC input and the additional power source (38) supplies the associated power board (44) with DC power.

- 5 12. The household appliance (10) according to anyone of the preceding claims,  
characterized in that  
the additional power source (38) is controllable independent-  
ly from the power supply system and/or the second heating  
10 system is controllable independently from the first heating system.
13. A method for operating a household appliance (10), particularly a cooking appliance, more particularly a cooking hob,  
15 specifically an induction cooking hob, wherein the household appliance (10) during an operating program consumes electrical power supplied by a power supply system, in particular by a power supply line, and, simultaneously, additional electrical power supplied by an additional power source (38).
- 20 14. The method according to claim 13,  
characterized in that  
a first heating system provides an item to be treated with thermal energy during consumption of electrical energy supplied by the power supply system and, particularly during an  
25 operating program with a boost function or during an operating program with fast treatment function, a second heating system provides the item to be treated with additional thermal energy during consumption of electrical energy supplied  
30 by the additional power source (38) depending on a user's selection.
15. The method according to claim 14,

characterized in that  
the power supply system charges a rechargeable power storage  
means of the additional power source (38) during a non-  
operation period of the second heating system and the re-  
5 rechargeable power storage system is discharged during an oper-  
ation period of the second heating system, the charging pref-  
erably being suspended during the operation period of the  
second heating system.

**Abstract**

A household appliance (10), particularly a cooking appliance, more particularly a cooking hob, specifically an induction cooking hob, comprises a consumer load, which may be a heating system comprising at least one heating element (32), a mains connection unit (42) connected or connectable to a power supply system, in particular a power supply line, for supplying the household appliance (10) with electrical power, and an additional power source (38) for supplying the household appliance (10) with power in addition to the power supplied by the power supply system.

Further, a method for operating such a household appliance (10) is disclosed. During an operating program electrical power supplied by a power supply system is consumed. In addition and simultaneously, electrical power supplied by an additional power source (38) is consumed as well.

20 Fig. 3

Fig.1

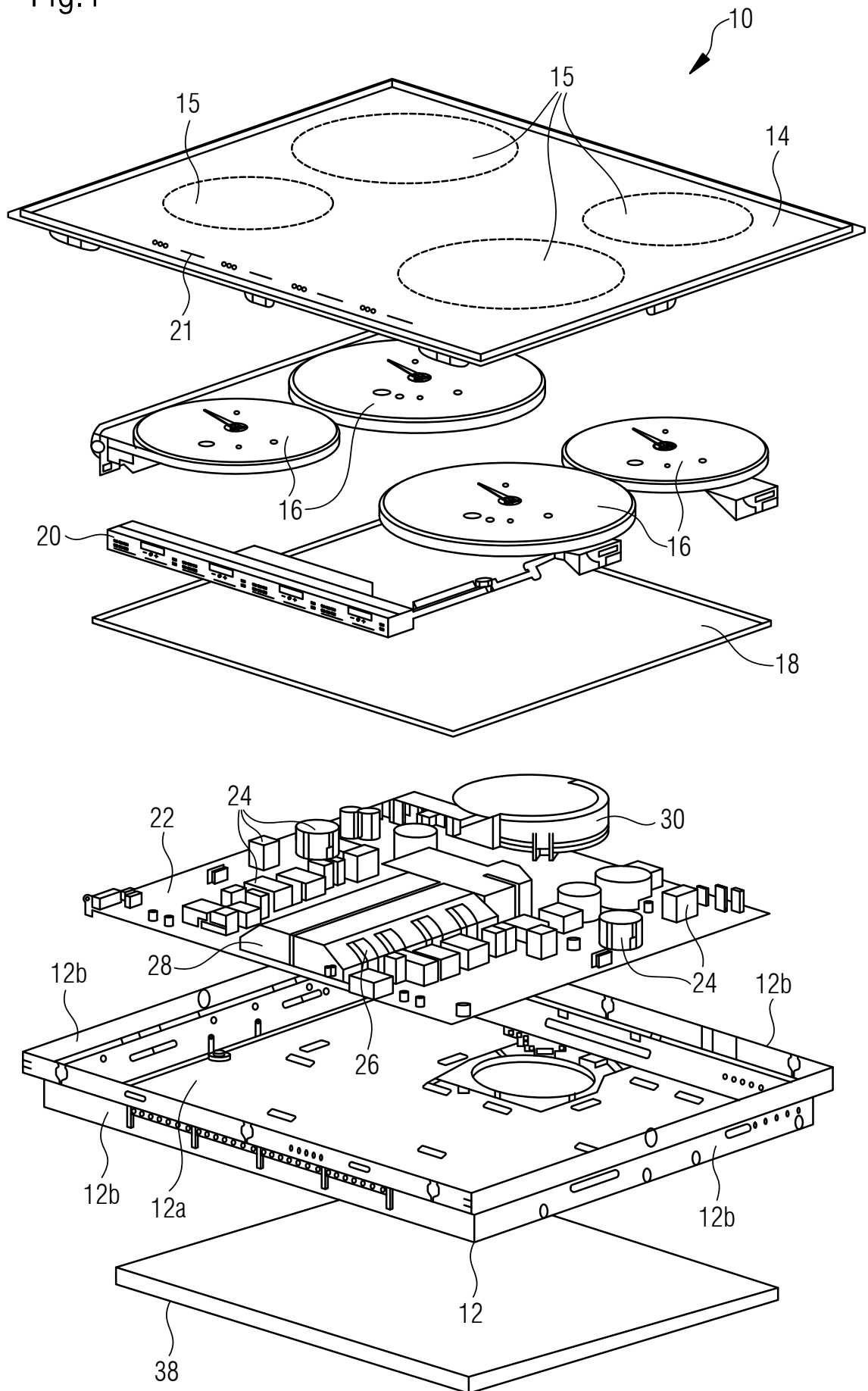

Fig.2

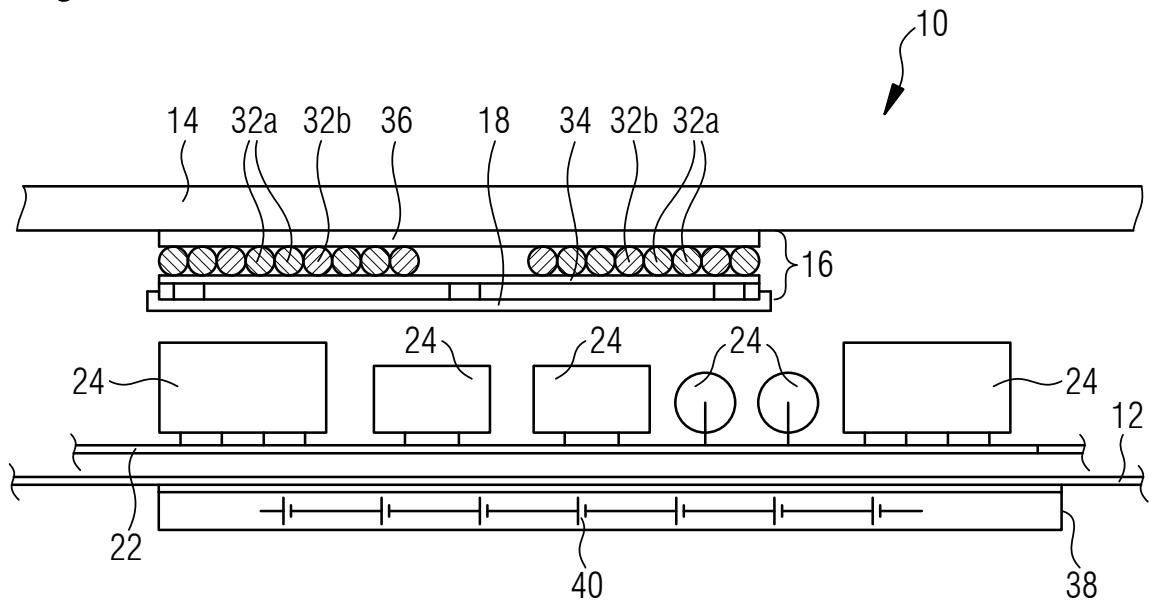

Fig.3

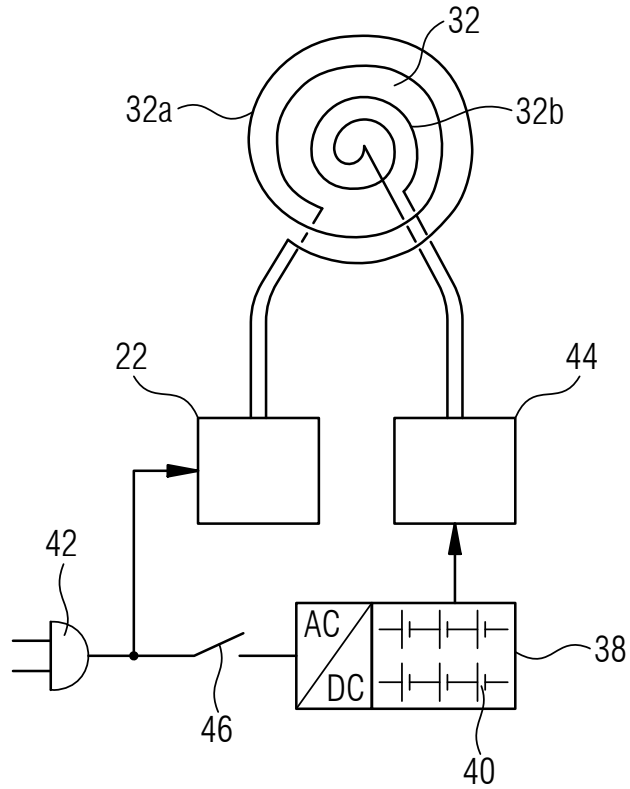

Fig.4

