

FACTA UNIVERSITATIS

Series: **Mechanical Engineering** Vol. 19, N° 1, 2021, pp. 67 - 78

<https://doi.org/10.22190/FUME201212010P>

Original scientific paper

THE CERAMIC MODULAR HEAD IMPROVEMENT IN THE DESIGN OF A TOTAL HIP REPLACEMENT

Vladimir Pakhaliuk¹, Aleksandr Poliakov¹, Ivan Fedotov²

¹Sevastopol State University, Sevastopol, Russian Federation

²National Research Nuclear University MEPhI, Moscow, Russian Federation

Abstract. *For the first time, a design of a modular ceramic ball head of a total hip joint replacement (THR) friction pair has been developed, which has the properties of a metal in conjunction with the stem neck and the properties of a ceramics on bearing surface of the pair. This is achieved by creating a low-cost, low-toxic, durable fixed connection of the head made of alumina or zirconia ceramics and the titanium-based alloy sleeve to obtain a brazed joint that is efficient in human synovial fluid. With the help of finite element analysis, a quantitative assessment of the strength and rigidity of the proposed head design was performed and its use in modern hip arthroplasty was indicated. The approbation of the proposed design solutions for creating a THR ceramic head with a titanium-based alloy sleeve brazed was carried out.*

Key words: *Total hip replacement, Ceramic friction couple, Modular ceramic ball head, Brazing*

1. INTRODUCTION

In the designs of modular total hip joint replacements (THR), which have found wide application in medical practice in the treatment of diseases and injuries of the hip joint, spherical friction pairs are most often used with heads, made of metal alloys (cobalt-chromium, titanium-based), ceramics (alumina - Al_2O_3 , zirconia - ZrO_2) and their mixtures. At the same time, both types of materials, metal and ceramics, have fairly good tribological properties in terms of minimizing wear of a spherical sliding friction pair due to their high hardness. But the ions of cobalt and chromium, which are released from the all-metal head, are toxic in nature, have the property of spreading throughout the body and accumulating in its vital tissues, which in some cases can lead to very severe allergic complications [1]. In addition, in [2], it was studied that one of the lowest friction coefficients is possessed by a pair of ceramic head-on-polyethylene liner made of ultra- high molecular weight polyethylene

Received December 12, 2020 / Accepted January 29, 2020

Corresponding author: Vladimir Pakhaliuk

Sevastopol State University, Universitetskaya Str. 33, 299053 Sevastopol, Russian Federation

E-mail: pahaluk@sevsu.ru

(UHMWPE). The simulation results we performed earlier indicate that the amount of wear products of such a friction pair is significantly less than in a metal-on-UHMWPE or metal-on-metal pair [3-4]. In addition, it can be reasonably assumed that when using a friction pair of a partially regular micro texture in the form of dimples, applied, for example, to the THR head surface, a ceramic-on-UHMWPE pair will be more effective from a tribological point of view. The presence of such an artificial lubricant pockets, as a rule, prevents the bonding of articulated surfaces of the tribological pair, promotes removal of the wear process products into dimples from a contact area, and feeds the frictional contact with a portion of the lubricant during its operation [5]. Thus, the above performances of THR with a ceramic-on-UHMWPE friction pair indicate their competitive advantages compared with analogues. However, in order to achieve a global advantage, it is necessary at the design and technological levels to ensure the necessary strength of the connection between the ceramic head and the THR metal stem, as well as its resistance to shock loads.

Both metal and ceramic heads are mated with THR stem neck made of titanium-based alloy through the presence of a blind taper hole in them. In this case, the acetabular part of the THR (liner into the cup) mated to the head can be made of both ceramics and UHMWPE. But ceramics has one of the essential disadvantages - fragility. Therefore, in the place of the specified conical connection in case of extreme load, for example, when a patient jumps from a height, there is a high probability of the ceramic head destruction [6-7]. At the same time, in the case of revision prosthetics, it becomes necessary to install a THR with only a ceramic pair, since it is impossible to extract from the tissues all small sharp fragments of destroyed ceramics, which, if they get into a friction pair, especially with the use of UHMWPE, would lead to a catastrophic avalanche-like wear of a new pair [6].

In view of the foregoing, it becomes obvious that the reliability of the THR, along with ensuring the best tribological properties, can be significantly increased if the design connection of the tapered stem neck with the ceramic head is provided, which would exclude the destruction of ceramics under any heavy loads (including extreme ones), arising from the vital activity of the patient.

Known THR head [8] consists of external and internal elements, of which the internal is a metal base, for instance of tantalum, with a tapered hole. The hole has a various shape of the outer surface, on which an outer element made of ceramics or, for example, sapphire single crystal, the outer surface of which has a spherical shape.

This design has a number of obvious disadvantages. First, it is unclear what technology should be used to deposit ceramics on the inner metal element made of tantalum in order to provide a strong and reliable connection between them. Most likely, such a technological process must take place at a very high temperature. It is known that the most widely used types of ceramics for such heads are alumina and zirconium ceramics or their mixture [9]. But the temperature coefficient of linear expansion of tantalum and, for instant, alumina ceramics, differs on average by 25%, which, when the head cools down, in the case of a presumptive deposition of such a layer of ceramics, can lead to the probable destruction of this brittle layer due to its different deformation as compared to the metal tantalum base. Similar consequences will take place in the case of using sapphire, which is characterized by pronounced anisotropic properties. The most probable technology for its deposition also requires growing a single crystal on tantalum. Consequently, when developing it, it is necessary to take into account differences up to 30% in the temperature coefficient of linear expansion of sapphire in two mutually perpendicular directions with the temperature coefficient of linear expansion of tantalum.

Secondary, processing the outer surface of a spherical sapphire head is a very laborious operation, provided that the required accuracy of its dimensions and shape is achieved. And, finally, the tantalum material itself and the indicated probable technologies for creating the outer ceramic layer on it are very expensive and will not be competitive with existing analogues on the market.

Another solution was proposed and promoted by Smith & Nephew, which made the head from an all-metal zirconium alloy (97.5% zirconium and 2.5% niobium), and on its surface formed a layer of zirconia ceramics (zirconia oxide), called OXINIUM, through a special process of blowing the head oxygen and its diffusion into the crystal structure of the metal alloy [10]. According to the company's advertising, such a head has the property of metal and ceramics at the same time, which should prevent the damage of ceramics and increase the wear resistance of the THR. But the thickness of the ceramic layer at the specified head does not exceed 7 microns, at the border of which there is a sharp decrease in hardness. In addition, despite the company's advertising materials, the degree of adhesion of the ceramic layer to the base metal at such a thickness remains debatable. At the same time, there is a high probability of damage to the ceramic layer when foreign abrasive bodies enter the friction pair, since there is still not a sufficient amount of long-term reliable information on the performance of THRs with such materials *in vivo*. In addition, the head has an increased mass due to the high specific gravity of the zirconium alloy, which shifts the center of mass of the entire THR from the position of the center of mass of the natural joint, increasing the shoulder of the dynamic component of the load at the THR and stimulating the weakening of its fixation.

A number of THR designs have been proposed, where adapter sleeves are used to interface the ceramic head with the stem neck. For instant, in the design of the ceramic head, a cylindrical hole is made for mating with the stem neck, where a plastic sleeve is inserted [11]. Since the head, as a rule, is fixed from axial movement in the THR acetabular component during its installation, then in the presence of certain dynamic loads during the operation of the THR, this will contribute to the creation of axial cyclic forces, leading to a relative displacement of the head and stem in their cylindrical connection. The presence of a soft plastic sleeve aggravates the process, leading to loosening of the non-strength connection between the head and neck, instability in the elements of the THR, disruption of the joint biomechanics and manifestation of pain syndromes, and, consequently, the need for revision prosthetics. In another known design of the THR, taper mates of the adapter metal sleeve made of titanium-based alloy are made both with the head and with the stem neck. But the use of such a sleeve is mainly recommended for revision prosthetics for fixing the head on the stem, which is well-fixed in the femur and does not require its extraction, and the neck of which has mechanical damage [12-15]. In [16], a numerical analysis of a sleeve connection with a ceramic head was carried out, which shows an improvement in the stress-strain state of ceramics in the case of using a sleeve. But on the other hand, it was shown in [17] that during the operation of the THR there are micro displacements of the sleeve, both rotational and translational, in the hole of the head and on the stem neck. Therefore, this phenomenon does not exclude the possibility of ceramics destruction when exposed to extreme loads on the THR.

There is also a THR ball head [18], which consists of external and internal elements, the external of which contains a blind cylindrical hole and is a part made entirely of ceramics or, for instance, a single crystal of sapphire or ruby, with an external spherical surface. In the specified hole there is an internal head element - a cylindrical metal sleeve with an internal taper through hole and an external shoulder from the side of the inlet of the taper hole. For fixed mating of the two head elements, an adhesive or soldered joint is used.

But this head has a number of significant disadvantages. A constructive drawback in the form of the presence of an external shoulder on the internal element of the head (sleeve) leads to a serious decrease in the range of angular motion in the artificial joint of the patient. In this case, to a probable impingement of the cup liner edge with the specified shoulder during the operation of the joint and, thereby, to a possible violation of the edge integrity and the ingress of products of its destruction into the tissues surrounding the THR. The technological disadvantage lies in the fact that the soldering of ceramics or single crystals to the metal sleeve, indicated in the reference, must be carried out with biocompatible solders. But in the available literature, the soldering as a low temperature process with biocompatible solders practically does not occur and is probably hardly possible, because only active metals can "wet" the ceramics and among them only 3 are biocompatible - titanium, zirconia and hafnium, and brazing alloys based on titanium, zirconia and hafnium are high-temperature. In this case, when using brazing (a high-temperature process) for anisotropic sapphire single crystals and ruby to a metal sleeve with different temperature coefficients of linear expansion, cracks are likely to form in ceramics, which is unacceptable in products of this type.

Thus, the main aim of this work is to develop the design of a THR modular ceramic head, which has the properties of a metal in joint with the stem neck and the properties of a ceramics on the bearing surface of a friction pair by creating a low-cost, low-toxic, strong connection of alumina or zirconia ceramics and a titanium-based alloy to obtain a brazed joint that is efficient in human synovial fluid.

2. HEAD DESIGN DEVELOPMENT

Another technological disadvantage relates to the creation of an adhesive bond, for example, specified in [18]. If the size of the gap between the elements to be brazed can be on the order of a proportion of a millimeter, then in order to achieve a strong adhesive bond, this gap should already be several millimeters. This statement is confirmed by the image in Fig. 1, which shows a section of the adhesive joint between the stem neck of the titanium-based alloy and the head made of alumina ceramics with an outer diameter of 32 mm of the existing non-modular THR design. Here, component 1 is an alumina ceramic head, 2 is a titanium-based alloy stem neck, and 3 is an adhesive layer connecting these two components of the THR. The section shows that the thickness of the glue at this diameter of the head is about 4.5 mm and, in this case, there is no sufficiently strong thickness of the head at the inlet of its tapered hole to organize modularity when the adapter sleeve fastens by the glue. Therefore, in the above THR design, only the stem neck can be motionlessly connected to the head.

2.1. Design description

To solve the problem, a THR head model was developed, shown in Fig. 2, which consists of an external ceramic element 4 with a spherical outer surface 5 and an internal blind hole, in which the internal head element is placed - an adapter sleeve 6 made of titanium-based alloy, for example, VT1-0 (pure titanium) or Ti-6Al-4V. The sleeve is made, for instant, with a cylindrical shape of the outer surface 7 (but it can also be conical) without an outer shoulder, and its inner end 8 is made of any shape, and it contains an axial blind tapered hole 9. The surface of the hole in ceramic element 4, for example, of a cylindrical shape, mating with the surface 7 contains a specially made macro-texture for improving the adhesion of the brazing alloy with the ceramics while brazing. The sleeve 6 in the specified hole of the element 4

along its surface 7 is installed with a gap of about 50-200 micrometers at the radius and with a similar gap along the surface 8 to fill the gap with biocompatible brazing alloy, and is fixedly connected to the element 4 by means of brazing. At the moment, the design of this head is undergoing the stage of obtaining a patent for an invention.

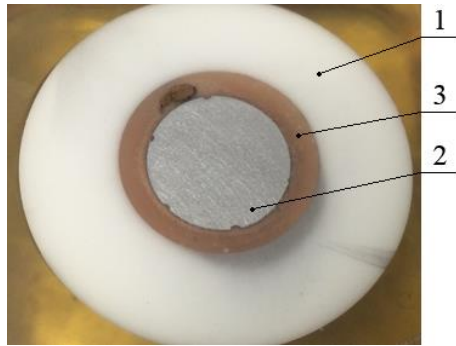

Fig. 1 Sectional view of the adhesive joint between the stem neck of the titanium-based alloy and the alumina ceramic head

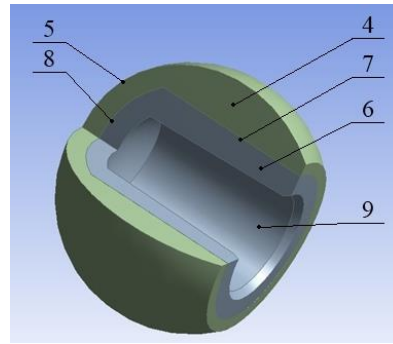

Fig. 2 Model of the proposed THR head design with a quarter of its cut along the axis of symmetry

The proposed design of the THR head provides the following. Reducing the intensity of the occurrence of fretting-corrosion in the conical connection of the THR stem neck and the head sleeve, made of a homogeneous material, which excludes the occurrence of an electrolytic couple between them in an aggressive environment of the body, as well as its exclusion in the joint of the sleeve and the ceramic head due to the creation of a fixed connection between them. The absence of an external shoulder at the sleeve provides an expansion of the angular range of motion in the hip joint, which is very important for the patient, and significantly reduces the likelihood of impingement of the THR cup liner edge with the stem neck, thereby increasing THR resource. In addition, to create a strong brazed joint with ceramics, it is necessary to make a special macro-texture on the ceramic surface of the joint to increase its active area and improve the adhesion of the brazing alloy to the ceramics. For this purpose, a specially made macro-texture is applied to the ceramic element of the head on the cylindrical or conical surface of its hole. For instance, it can be provided by a milling method and have the form of concentric grooves with any pitch and depth (for example, a pitch of 1 mm and a depth of 500 μm), and such a texture is necessary to ensure high strength of the brazed joint. The brazing alloy wetting of the ceramic element with the applied macro-texture is provided by the preliminary application of a titanium coating on it by the method of gas-phase or magnetron deposition. And at the blind end of the sleeve and the inner end of the holes in the ceramic element, the surface shape can be any, since brazing alloy is placed in this area, which can rise into the gap, both due to capillary forces, and by creating possible additional axial pressure on the sleeve.

The specified head design combines all the advantages of both metal and ceramic heads. Among them, the presence of a metal sleeve with a traditionally tapered axial hole provides a fixed connection of the ceramic head with the sleeve due to the absence of micro displacements along the outer surface of the sleeve, thereby significantly increasing the stability of the THR and protecting the head from possible splitting in the tapered conjunction.

All of these factors create conditions under which the service life of the entire THR increases and thereby the patient's quality of life improves.

The design of the spherical joint of the THR with the indicated head is shown in Fig. 3. Here, 10 is the cup liner of the THR acetabular component, which is articulated with its inner spherical surface with the corresponding surface 4 of the head, thereby providing the formation of a spherical friction pair. Component 11 is a part of the THR tapered stem neck, on which the head is placed during implantation of the THR.

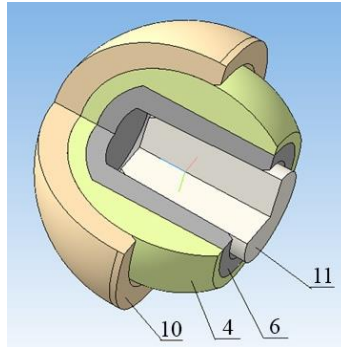

Fig. 3 Spherical joint design of THR with head developed

2.2. Finite element simulation

To confirm the operability of the THR composition shown in Fig. 3, its finite element analysis was performed for a standard outer head diameter of 32 mm and a tapered hole with a standard cone 14/16 at a length of 1 inch. In the designs of THR, three standard external head diameters are mainly used: 22, 28 and 32 mm. Moreover, the larger its diameter, the higher is the reliability of the THR, since it is more resistant to dislocation. From these positions, a head with a diameter of 32 mm was adopted for research.

During the research, the following materials were accepted for the corresponding THR elements. For ceramic head and liner: alumina ceramic (Al_2O_3) with Young's modulus $E=380$ GPa, Poisson's ratio is $\mu=0.22$, ultimate strength in bending is $\sigma_b=325$ MPa. For the internal element of the head (sleeve) and for the stem, titanium-based alloy VT1-0 was used: Young's modulus is $E=110$ GPa, Poisson's ratio is $\mu=0.32$, conditional yield stress $\sigma_{0.2}=265$ MPa.

In the ANSYS Workbench software, the 2-D axially symmetric problem of interaction of a ceramic head with an adapter sleeve and with no sleeve was solved. Since the aim of the study was to compare stresses, strains and deformations in the heads of two designs, the type of THR static analysis with a mesh element size of 0.5 mm, obtained by curvature size function, was chosen. Meshing method was quadrilateral dominant, which known to give good accuracy and acceptable solution time.

In this case, for the presence of a sleeve, the use of brazing between the outer surface of the sleeve 6 and the inner surface of the hole in the ceramic head 4 was simulated by the bonding option. The contact between the stem neck 11 and the sleeve 6 in the presence of the sleeve or between the ceramic head 4 and the stem neck 11 in the no sleeve case was simulated with the rough option. The boundary conditions were set as a complete fixation the liner 10 along its outer surface from all displacements. The load F in the form of a concentrated force of 2.6 kN applied to the stem neck, acts along its longitudinal axis and is

the projection of the reaction on the head longitudinal axis of the concentrated maximum force of 3.0 kN, acting vertically on the head and induced by the acetabular component of the THR in accordance with ISO 14242-1 Standard [19]. The load profile specified in the above Standard has a variable shape with a maximum value of 3.0 kN, a minimum value of 0.3 kN and a period of 1 Hz. When designing the loading mechanism for the hip joint wear simulator according to the shape of this profile, the values of dynamic loads additionally acting on the hip joint were investigated [20]. It turned out that they do not exceed 3.5% and are negligible compared to the load indicated in this study, and, based on this, a static analysis was performed here.

3. RESULTS AND DISCUSSION

As a result of the solution, patterns of the distribution of contact pressures and deformations on the contact surfaces, as well as stresses and strains and total deformations in all components of the finite element model over the thickness of their section, are obtained. But from results obtained, we are mainly interested in solutions in both cases for the ceramic element of the head, since the excessive loads can lead to failure of this element with high probability. Fig. 4 shows the model in the form of a head half-section of the THR with no sleeve, and Fig. 5 shows the results of calculating the indicated head with patterns of stress, strains and total deformation distributions. Fig. 6 shows the model in the form of a head half-section with a sleeve brazed, and Fig. 7 shows similar calculation results for the said head. The sleeve is placed in the head hole by reducing the thickness of its wall and has a thickness of 2 mm at the inlet to the hole, while maintaining the fitting size for the stem neck.

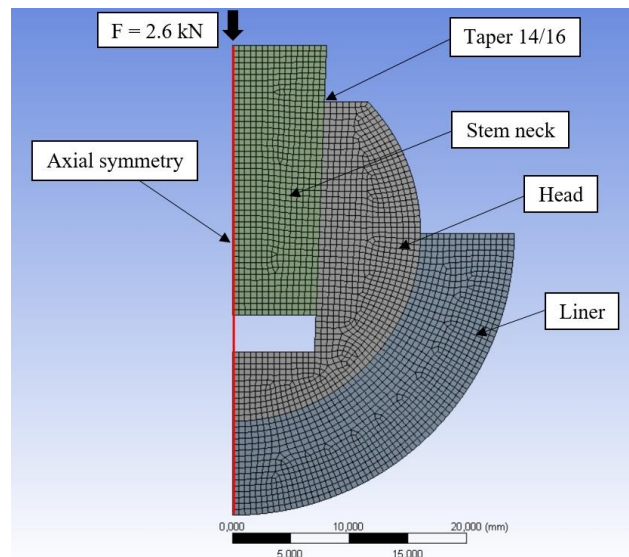

Fig. 4 The model of the THR head without a sleeve

From the analysis of Fig. 5, which shows the results of calculating the THR ceramic head without a sleeve, it can be seen that the most dangerous area manifests itself at the inlet of the

stem neck into the tapered opening of the head. Here, the maximum equivalent von Mises stresses in the ceramic head are 19.3 MPa at the hole inlet, equivalent strains is $5.1 \cdot 10^{-5}$ and total deformation (displacement) reaches $3.3 \cdot 10^{-4}$ mm.

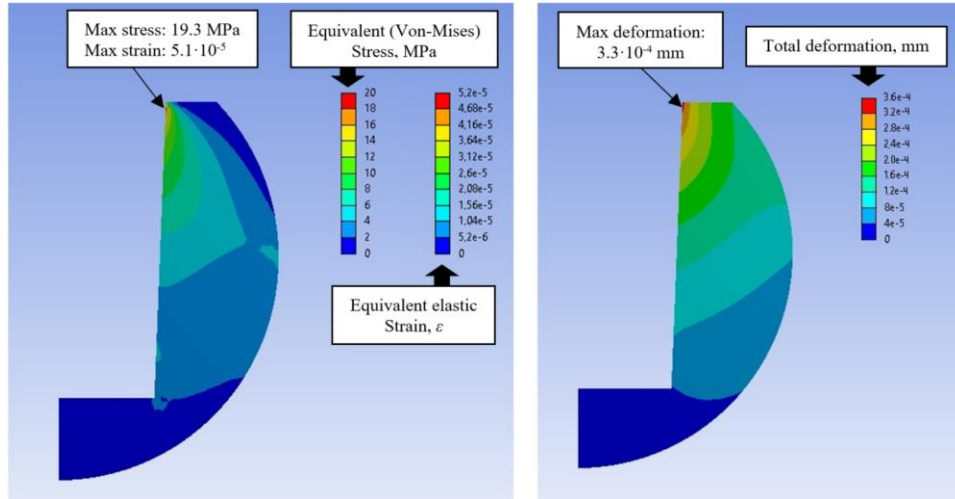

Fig. 5 The results of calculating the THR ceramic head without a sleeve, shown in Figure 4: on left is the distribution of equivalent von Mises stresses and strains, and on right is the distribution of total deformations

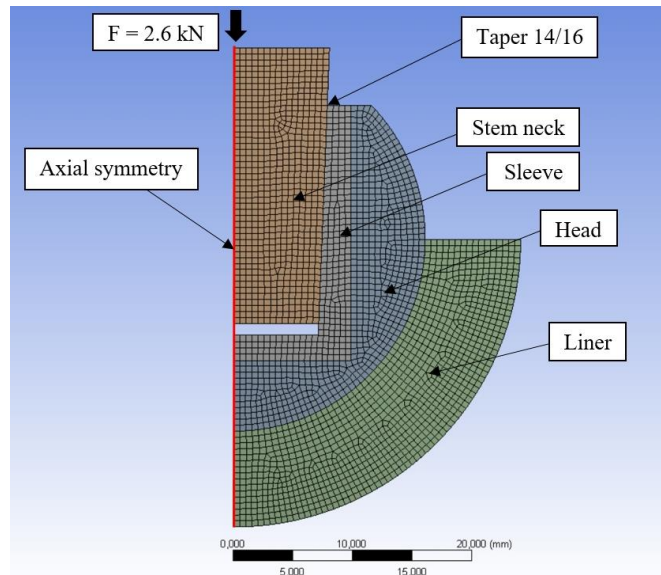

Fig. 6 The model of the THR head with a sleeve brazed made of VT1-0 alloy while maintaining the fitting size for the stem neck

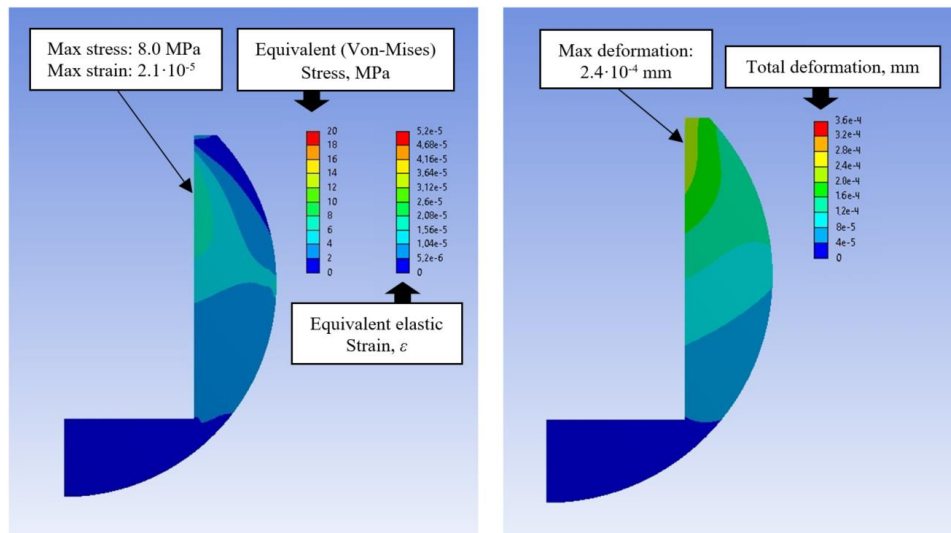

Fig. 7 The results of calculating the THR ceramic head with the sleeve shown in Figure 6: on left is the distribution of equivalent von Mises stresses and strains, and on right is the distribution of total deformations

Under excessive shock loads, the formation and growth of cracks begins from here. The analysis of Fig. 7, which shows the results of calculating the THR ceramic head with a sleeve, shows that the most dangerous zone has shifted to the area where the ceramics has practically the greatest thickness. In this case, the maximum equivalent von Mises stresses in the ceramic head decreased by more than 2 times to 8.0 MPa, equivalent strains to $2.1 \cdot 10^{-5}$ and total deformation to $2.4 \cdot 10^{-4}$ mm. The visualization of the magnitude and distribution of total deformation is quite informative, since if it is present, it becomes obvious how the deformation is redistributed between interacting bodies, and its reduction in the presence of a titanium-based sleeve indicates that the latter "takes" the deformation onto itself, since it is softer than ceramics.

This confirms the hypothesis that the presence of the sleeve improves the stress-strain state of the ceramic head [16]. But in the investigated case of the head design, the problem is posed and considered not only the above improvement of the stress-strain state, but also, mainly, the eliminating of possible destruction the ceramics under excessive loads. This is achieved by creating a fixed connection of the metal sleeve with the ceramics by brazing, which excludes the axial micro displacement of the sleeve in the head hole, which takes place in its existing designs [17], and thereby eliminates the occurrence of the splitting effect in ceramics. At the same time, the hole in the developed ceramic head can be either cylindrical or conical with a similar shape of the outer surface of the sleeve. In existing designs of a head with a sleeve, the hole is made only of a conical shape, and when the sleeve is axially displaced from the action of axial force, a splitting effect is created in the ceramics, which increases the likelihood of its destruction in extreme cases.

To demonstrate the feasibility of the proposed design solutions, two standard ceramic heads with an outer diameter of 32 mm with titanium-based alloy sleeves brazed were manufactured. Since the design of the head is new and has no analogues in the world, it

was important to check the possibility of obtaining it by using high-temperature brazing with titanium-based alloy. The internal tapered opening of the head was machined to create grooves and thereby increase the contact area of the brazing alloy with the ceramics. The biocompatible powder brazing alloy of the TiZrCo system was laid on the bottom of the head hole. Brazing of the two heads was carried out in a Xerion Xvac 1600 vacuum oven to prevent oxidation of the brazing alloy and titanium-based alloy sleeve. The every sleeve is made with inner thread hole to secure the grip of the testing machine. An alumina ceramic brazed head with an indicated sleeve is shown in Fig. 8.



Fig. 8 Alumina ceramic head with titanium sleeve brazed

Mechanical tests of the brazed heads were carried out on an Instron LX150 testing machine. During the tests, the separation of the sleeve from the alumina ceramic head was simulated by using special assembly. The deformation diagram for two brazed heads is shown in Fig. 9.

The results obtained show that the brazed sleeve can withstand a pull-off load of over 20000 N. The test was carried out either to the destruction of the head, or to the detachment of the gripping pin. The diagram 9 shows that for sample 1 there was a breakdown of the ceramic element of the head, and for sample 2 - a rupture of the pin.

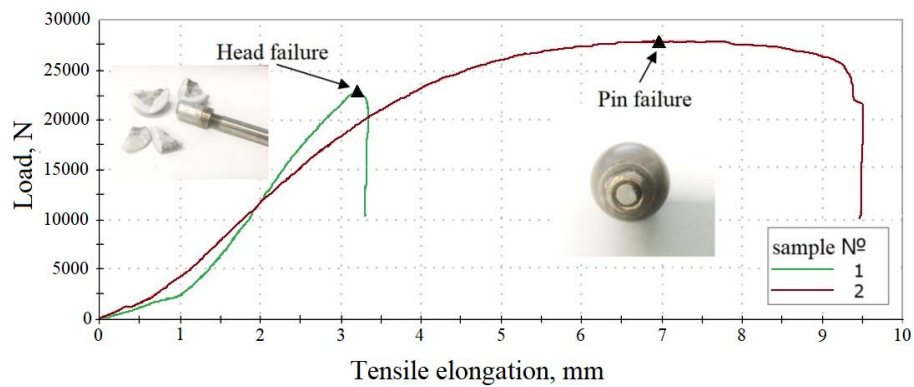

Fig. 9 Deformation diagram of the brazed joint of the THR ceramic head with a titanium-based alloy sleeve

Preliminary mechanical tests on two specimens conducted to evaluate the possibility of a reliable fixation of the sleeve inside the head. In both cases, the failure was not along the brazed joint, and, therefore, the structural strength of the joint is higher or equal to the strength of the head itself. In addition, the resulting load values will never be achieved in the brazed joint. To determine the average bond strength, additional experimental studies should be carried out on a larger number of samples. Thus, preliminary tests indicate the possibility of obtaining a strong brazed joint of a ceramic head with a titanium-based alloy sleeve for the manufacture of a THR with increased reliability.

4. CONCLUSION AND OUTLOOK

For the first time, a design of a modular ceramic ball head of a THR friction pair has been developed, which has the properties of a metal in conjunction with the stem neck and the properties of a ceramics on the bearing surface of the friction pair. This is achieved by creating a low-cost, low-toxic, durable fixed connection of a head made of alumina or zirconia ceramics and a titanium-based alloy sleeve to obtain a brazed joint that is efficient in human synovial fluid. With the help of finite element analysis, a quantitative assessment of the strength and rigidity of the proposed head design was performed and its use in modern hip arthroplasty was indicated. The approbation of the proposed design solutions for creating a THR ceramic head with a titanium-based alloy sleeve brazed was carried out. Further investigations can be directed towards performing a similar analysis for the standard diameter of other head sizes. Further research will be directed towards performing additional experimental studies on a larger number of samples to obtain more accurate statistical indicators of the average strength of the specified brazing joint, as well as to perform a similar analysis for the standard diameter of other head sizes. In addition, it is planned to simulate the impact test of the developed head in the LS Dyna software to take into account the severe dynamic process of its loading, leading to the destruction of ceramics, as well as its wear tests in accordance with ISO 14242-1 at the simulator of Sevastopol State University [21].

Thus, the studies performed make it possible to move forward the creation of a THR design with high tribological performances along with an increased service life compared to existing designs, which will help to reduce the likelihood of patient revision prosthetics and improve their quality of life in the postoperative period.

Acknowledgement: *The study was carried out with the financial support of the Russian Foundation for Basic Research (grant No. 20-03-00046A).*

REFERENCES

1. Poliakov, A., Pakhaliuk, V., Popov, V.L., 2020, *Current Trends in Improving of Artificial Joints Design and Technologies for Their Arthroplasty*, *Frontiers in Mechanical Engineering* 6, Art. 4, 16 p.
2. Tankut O.V., 2010, *Substantiation of hip arthroplasty using single crystal sapphire in the joint of hip prosthesis*, PhD Thesis, Sytenko Institute of Spine and Joint Pathology, Ukraine, 356 p.
3. Pakhaliuk, V., Polyakov, A., Kalinin, M., Kramar, V., 2015, *Improving the Finite Element Simulation of Wear of Total Hip Prosthesis' Spherical Joint with the Polymeric Component*, *Procedia Engineering*, 100, pp. 539-548.

4. Pakhaliuk, V., Polyakov, A., 2018, *Simulation of wear in a spherical joint with a polymeric component of the total hip replacement considering activities of daily living*, Facta Universitatis-Series Mechanical Engineering, 16(1), pp. 51-63.
5. Pakhaliuk, V., Polyakov, A., Kalinin, M., Bratan, S., 2016, *Evaluating the impact and norming the parameters of partially regular texture on the surface of the articulating ball head in a total hip joint prosthesis*, Tribology Online, 11(4), pp. 527-539.
6. Kumar, N., Arrora, Gen N.S., Datta, B., 2014, *Bearing surfaces in hip replacement – Evolution and likely future*, Med J Armed Forces India, 70(4), pp. 371-376.
7. Gallo, J., Goodman, S.B., Lostak, J., 2012, *Advantages and disadvantages of ceramic on ceramic total hip arthroplasty: A review Article*, Biomed Pap Med Fac Univ Palacky Olomouc Czech Repub, 156(3), pp. 204-212.
8. Volkov, V.V., Kovalenko, O.V., Kalinin, M.I., Pakhaliuk, V.I., Poliakov, A.M., Brekhov, A.N., 2011, *Hip replacement head*, UA Patent No 95,382. Kharkiv: Ukrainian Institute of Intellectual Property.
9. Piconi, C., Maccauro, G., Muratori, F., Branch Del Prever, E., 2003, *Alumina and Zirconia Ceramics in Joint Replacements*, J Appl Biomater Biomech, 1(1), pp. 19-32.
10. Hunter, G., Dickinson, J., Herb, B., Graham, R., 2005, *Creation of Oxidized Zirconium Orthopaedic Implants*, Journal of ASTM International, 2(7), pp. 1-14.
11. Korzh, M.O., Filipenko, V.A., Radchenko, V.O., Litvinov, L.A., Voloshin, O.V., Sliunin, Y.V., Timchenko, I.B., Golukhova, A.G., Tankut, V.O., Tankut, O.V., 2007, *Hip Endoprosthesis*, UA Patent No 79,551. Kharkiv: Ukrainian Institute of Intellectual Property.
12. Massin, P., Lopes, R., Masson, B., Mainard, D., 2014, *Does BioloX® Delta ceramic reduce the rate of component fractures in total hip replacement?*, Orthopaedics & Traumatology: Surgery & Research, 100(6), Supplement, pp. S317-S321.
13. Dickinson, E.C., Sellenschloh, K., Morlock, M.M., 2019, *Impact of stem taper damage on the fracture strength of ceramic heads with adapter sleeves*, Clinical Biomechanics, 63, pp. 193-200.
14. Leibiger, T., McGrory, B.G., 2015, *Custom titanium sleeve for surgical treatment of mechanically assisted crevice corrosion in the well-fixed, noncontemporary stem in total hip arthroplasty*, Arthroplasty Today, 1, pp. 107-110.
15. Güttler T., 2006, *Experience with BIOLOX® option revision heads*. In: Benazzo F., Falez F., Dietrich M. (eds) *Bioceramics and Alternative Bearings in Joint Arthroplasty. Ceramics in Orthopaedics*, Steinkopff, pp. 149-154.
16. Falkenberg, A., Dickinson, E.C., Morlock, M.M., 2020, *Adapter sleeves are essential for ceramic heads in hip revision surgery*, Clinical Biomechanics, 71, pp. 1-4.
17. Koch, C.N., Figgie, M.J., Figgie, M.P., Elpers, M.E., Wright, T.M., Padgett, D.E., 2017, *Ceramic Bearings with Titanium Adapter Sleeves Implanted During Revision Hip Arthroplasty Show Minimal Fretting or Corrosion: a Retrieval Analysis*, HSS J., 13(3), pp. 241-247.
18. Bouvet, J.C., 1991, *Prosthesis ball joint*, EP Patent No 0,406,040. Arpajon: European Patent Office.
19. *Implants for surgery – Wear of total hip-joint prostheses – Part 1: Loading and displacement parameters for wear-testing machines and corresponding environmental conditions for test.* – ISO 14242-1:2002(E).
20. Pakhaliuk, V.I., Poliakov, A.M., Desyatov, I.B., Kalinin, M.I., Stupko, M.G., 2011, *The kinematic and dynamic performances of the loading mechanism of the hip joint wear simulator*, Annals of DAAAM & Proceedings, pp. 595-596.
21. Poliakov, O., Pakhaliuk, V., Lazarev, V., Shtanko, P., Ivanov, Y., 2013, *Stand and Control System for Wear Testing of the Spherical Joints of Vehicle Suspension at Complex Loading Conditions*, IFAC Proceedings Volumes, 46(25), pp. 106-111.