

See discussions, stats, and author profiles for this publication at: <https://www.researchgate.net/publication/253649617>

# Building a SOA-Based Model for Purchase Order Management in E-Commerce Systems

Conference Paper · April 2013

DOI: 10.1109/PICT.2013.27

CITATION

1

READS

715

2 authors:



Rebhi Baraka

Islamic University of Gaza

15 PUBLICATIONS 58 CITATIONS

SEE PROFILE



Yousef Alashqar

Al-Azhar University - Gaza

5 PUBLICATIONS 1 CITATION

SEE PROFILE

Some of the authors of this publication are also working on these related projects:



ontology engineering, big data analysis [View project](#)

## Building a SOA-Based Model for Purchase Order Management in E-Commerce Systems

Rebhi S. Baraka

Faculty of Information Technology  
Islamic University of Gaza  
Gaza, State of Palestine  
rbaraka@iugaza.edu.ps

Yousef M. Al-Ashqar

Department of Information Technology  
Al-Azhar University-Gaza  
Gaza, State of Palestine  
ashyousef@hotmail.com

**Abstract**—Purchase Order Management (POM) is one of the most popular E-Commerce applications conducted between B2C and B2B systems. In many cases nowadays POM components use integration approaches that lack interoperability and manageability features. The purpose of this paper is to build a SOA based model for POM in E-Commerce system that achieves the goals of interoperability and manageability. In this paper a technical model of POM E-Commerce system is presented and analyzed. A new POM model based on SOA solution is proposed that overcomes the shortcoming of currently used model. The main contribution of this paper is to align a SOA-based model to the B2C and B2B E-Commerce domain.

**Keywords:** E-Commerce; SOA; ESB; Web Services; POM

### I. INTRODUCTION

E-Commerce has drawn increasing attention recently in areas of research and development in information technology. E-Commerce generally refers to the conduct of business transactional or managerial activities using Internet technology via the Web. As E-Commerce models (e.g. B2C, B2B) and applications are widely employed in today's business environment [6], there are numerous papers and reports that have been written on E-Commerce and how the concept will change the way companies doing business. Nowadays, E-Commerce systems are characterized by complex Web applications that use different operating systems and technologies and have to face constant changes imposed by technological evolution. E-Commerce sites require the integration of software applications written in different programming languages and residing on different computer hardware distributed across the Internet. This leads to facing issues such as interoperability and manageability [19].

Purchase Order Management (POM) is one of the applications that are used to purchase goods or services from businesses. Purchasing is the act of buying goods and services that a customer needs. The creation of a management system for purchase orders is often an important part for consumers and businesses [19]. Conventional POM is a business process involving different IT systems. The corresponding sections and their interaction are shown in Figure 1. These sections depend on different Information Technology Systems that are built on different components of legacy systems, application servers, Web servers and database servers [4]. In addition the creation of a management system for purchase orders is often an important part for consumers and businesses. Therefore the problem in current B2C or B2B POM systems is that their constituent components such as sales,

shipping and billing use integration approaches that lack interoperability and manageability. They appear in the automation of processes and lead to poor communication and integration between these sections. This results in customer dissatisfaction, time consumption and excessive costs. This drawback persists strongly when these components belong to different businesses and use different technologies.

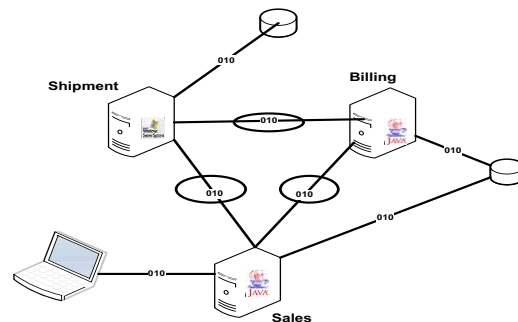

**Figure 1: Conventional Purchase Order Section**

Interoperability is the ability of multiple systems with different hardware and software platforms, data structures, and interfaces to exchange data with minimal loss of content and functionality [11]. Interoperability is important because it allows for connecting all parts of purchase order in a uniform way and the exchange of information between parts of purchase order successfully.

Manageability addresses the control and monitoring of applications throughout their lifecycle [13]. Manageability is important since there are different IT systems involved in the purchase order and it leads to achieving proper coordination between different IT sections of purchase order.

B2C or B2B and integration models still have several research issues which need to be addressed. Issues associated with conventional POM can be addressed and eliminated by transforming the current model into SOA architecture and realizing it using ESB. This is due to the advantages offered by this type of architecture such as interoperability, manageability and standardization by utilizing the description, discovery, and invocation of services.

We propose to use Web services in the SOA architecture for building a model for POM in B2C or B2B E-Commerce system. To realize the model, we specify its requirements including interoperability and manageability

and base it on suitable standards, approaches and technologies such as Enterprise Service Bus (ESB) [12].

The rest of the paper is organized as follows: Section *II* presents related works and applications of SOA in similar domains. Section *III* addresses and analyzes the current E-Commerce technical model for the POM. Section *IV* presents the proposed SOA-based model for the POM and a case study implementation for POM for B2C E-Commerce. Section *V* presents the conclusion and future work.

## II. RELATED WORK

The core idea of SOA is that software is transformed into a service based on distributed computing technology. SOA depends on a wide range of application services through the use of standard XML protocols and information formats in the Internet. These applications have been packaged into Web services, which use XML, SOAP, WSDL, UDDI and other technologies to realize their functionality as Web services interface [1, 20]. A good effort summary of research in SOA is presented in [13], defining the research roadmap of service-oriented computing and gives an overview of the state of the art of and grand challenges in the area.

A general E-Commerce model based on SOA is presented in [2]. The advantages of using business functionality approach, like obtaining the level of flexibility and interoperability necessary for the systems to adapt to future technological changes. The model takes into consideration the relationship of the company with its suppliers and customers and involves a SOA that takes into consideration the business functionalities of the system.

The current central database model, a core part of the Palestinian e-Government technical framework, is presented and analyzed [3]. A new central database model based on SOA solution is proposed. It overcomes the shortcomings of the currently used model that lacks the interoperability and manageability. The main contribution of the work is to align SOA conceptual framework to the e-Government domain. Future research efforts can be directed towards the realization of the proposed framework and the challenges that face its realization, as well as to address an enhanced SOA framework that considers governance and policies of Web services that are published by central database as well as local database service providers, both at the central and distributed database levels.

[17] analyzes and compares popular B2B frameworks that attempt to address such issues as interoperability and security between enterprises transacting business over the Internet. Standards such RosettaNet that facilitates Business-to-Business integration are discussed.

In [10], an architecture to build solution for B2B E-Commerce hubs platform based on dynamic SOA is proposed. It provided a comprehensive business services model and capitalizes on Web services as well as business process management and orchestration. The solution creates a clear, automatic path between the business specification layer and the technical implementation layer by combining both a SOA and management views in a

single framework. They assessed the capabilities of the proposed architecture in building vertical B2B e-marketplaces by applying the proposed architecture to the building of a vertical B2B e-marketplace for the oil and gas sector. They state future directions that can be extended to enhance the architecture such as the decomposition "Dynamic Web Services Definition" of Business Process Execution Language (BPEL). It can facilitate efficient SOA in the future which have not been completely addressed in the scope of the research.

In [20], they make concrete analysis and research of the application of SOA in B2B E-Commerce, to integrate the systems of several corporations and use the B2B E-Commerce systems synthetically becomes the most important problem, then propose to use the SOA to build a B2B E-Commerce model based on the J2EE platform, and describe the function of this model logically.

## III. PURCHASE ORDER MANAGEMENT

Nowadays, successful POM is a critical core competency for businesses and customers, since POM have different IT sections and the main concern is about making these sections work together and reducing their complexity. POM has so many interactions with its sections that must be automated. This requires integration to these sections to automate sharing of contents, communicate and exchanging data between POM sections such purchasing/sales section, inventory section and billing section. These sections are actively facing the interoperability and manageability problems.

### A. Technical Model of POM E-Commerce System

Traditional POM essentially has four classical main sections: sales, billing, inventory and shipping and looked as disparate information systems. The technical model of a E-Commerce system has different components and layers that need to be realized in order to have a fully functional technical model for the POM system.

Figure 2 depicts the POM E-Commerce technical model and its main layers and its different components.

The IT sections of POM are one of the layers of POM E-Commerce technical model. The important challenge to the POM model is interaction with these IT sections. It heavily involves and requires management consisting of interoperation, integration and exchanging data between different IT sections of POM application.

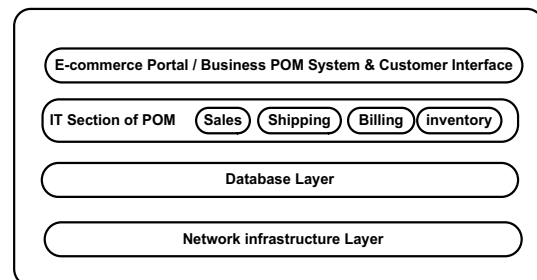

Figure 2: POM E-Commerce Technical Model

The POM Ecommerce model is composed of four layers: the portal interface layer, the IT section of POM layer, the database layer, and the infrastructure layer.

1. *Portal interface layer*: Presents the access interface that customers and businesses interact with POM E-Commerce system. It is considered as visible part to customers and business to access the Websites and portal and its POM application.
2. *IT Section Layer*: Contains the core IT section of POM such as sales, inventory, billing, and shipping. It provides the portal interface with all needed information to be exchanged between these sections to the portal interface layer that is needed to customer and business to complete the process of purchasing items goods or services.
3. *Database Layer*: This layer is for storing important data for different section of POM application. It addresses access gateway database sources that can easily manage data for IT section of POM such as products information, prices and inventory quantities.
4. *Infrastructure Layer*: This layer includes physical and low level software components, telecommunication network, protocols and standards (including EDI, RosettaNet, and XML), and operating systems. This layer presents the interface with networking devices and functionalities such as routing, hosting and control services.

#### B. Analysis of Current POM Model

In order to have interoperable and manageable POM E-Commerce model, the IT sections of the technical model depicted in Figure 2 must be integrated with each other into single coherent environment. These sections completely isolated from each other are designed to support functionality of POM. The IT sections layer has the role of traditional POM depicted in Figure 1. It consists of four important applications, namely sales section, inventory section, shipping section and billing that cover all processes that support POM system.

The interoperability between these applications is becoming more challenging because of the increased level of connectivity; the data formats become more diverse and need integration to be simple and fast. Interaction between these heterogeneous applications requires interoperability at other layers such network infrastructure layer and database layer or other business process. So it needs to agree on their joint business process such as document format, the data of the exchanged document as well as the communication protocol to exchange messages. The IT section layer is developed using different programming languages such VB, C, C++, .Net or Java and running on different platforms and using different technologies, and using components such application servers, Web servers and client browsers to access this traditional model.

The main characteristics of this traditional model are:

- The traditional POM model in B2C E-Commerce is processed automatically by computer systems on back ends such as server applications and Web browsers.

- The traditional POM model's sections use some application provided by outsourcing depending on the application service provider (ASP).
- POM has different information technology sections, these IT sections are designed independently as islands of automations with no information integration between them.
- Accessing a database is performed in two ways. The different sections of POM use the databases for updating any changing that can occur or reading the data for checking or validating information entered by customers.
- Managing and monitoring POM is performed using traditional tools which cannot automatically monitor and manage the fault that happens on sections of POM in software applications, network connections and hardware resources.
- Traditional POM depends on traditional middleware to connect its sections to translate messages and transactions into specific formats and integrate data flow from sections such sales, billing and inventory that make it difficult to manage these sections.

Interoperability is important to POM because the goal of interoperability is to allow different IT sections of POM to work together. This needs standards and protocols to describe software or hardware requirements that define common methods for communicating POM sections.

Standard that are relevant to POM model such as RosettaNet originally used a distributed approach to create PIPs [8], to facilitate B2B integration, and to support E-Commerce over existing Internet standards and lead to cost and extensibility benefits [17]. The standardized business processes described by RosettaNet simplifies cross organizational collaboration and B2B integration. So the degree of standardization offered still requires considerable manual effort during the setup of a B2B collaboration [18]. The scenario presented in [9], details the challenges in a practical B2B integration of RosettaNet collaborations. The scenario presented for purchasing is based on RosettaNet PIP3A4 Request Purchase Order [8].

We conclude from the above discussion that the mentioned characteristics of traditional POM model that is being criticized for various limitations some of them are listed below:

- The use of ASP in some sections of POM model leads to suffering from the inability to manage and integrate the applications of POM.
- Incompatibility between syntaxes of the languages of the POM sections.
- It is hard to trace and monitor the flow of transactions within the distributed sections of traditional POM due to the nature of traditional tools. This makes monitoring and management flow difficult and imposes manageability burden on POM.
- Using different software operating systems, different software development approaches, different high-level software languages for interfacing data/information, etc. lacks and decreases interoperability.

- The standard of PIP3A4 has very little hierarchical information embedded on it and lacks structure that is beneficial when the types of information exchanged change frequently and community agreement processes becomes a bottleneck rather than an aid to interoperability.
- Incompatibility between the syntaxes of PIP3A4 and the semantics of the terms used by the languages of software application systems. This is mainly due to arbitrary definitions provided by users to the developers of POM application. This leads to less interoperability.

As a result of the above mentioned limitations, there is a strong need for the development of an approach which would overcome these limitations of interoperability and manageability. Such features can be achieved if we adopt SOA solutions and use Web services which promote integration and ensure interoperability and manageability between sections of POM on multiple platforms in seamless communication by using new standards.

#### IV. THE PROPOSED MODEL AND CASE STUDY IMPLEMENTATION FOR POM FOR B2C E-COMMERCE

The proposed SOA-based model relies on SOA solution. The reason behind proposing to adopt SOA is because of its open architecture and platform standards that cope with heterogeneous systems in order to achieve high degree of interoperability and manageability. A typical architecture includes three main roles that interact using standard messaging. The roles are service provider, service registry and service client [5, 14].

Currently Web services are used to realize SOA architecture. Web services enable businesses to take advantage of connectivity and transaction processing, which relay on a set of standards to support interoperability among application developed in different languages and run in different platforms or operating systems. Web services effectuate information transmission through XML, independent form the platform and programming language. Basic Web services architecture contains three protocols (SOAP, WSDL, and UDDI) for facilitating interaction between service client and service provider and for standardization of releasing and finding of services [6, 16]. To realize the concept of SOA and to achieve a suitable and manageable integration infrastructure for Web Services, the concept of ESB should be introduced [13]. ESB is the infrastructure that integrates the components of the SOA concept; it integrates the applications, services, and the registry. ESB provides management and security functionality and enhances the QoS for the services provided by service providers linked to the ESB. The ESB is event driven and provides standard messaging between services, it routes and transports service requests to the appropriate service provide [15]. A typical ESB provides functions [7] such as: routing, message transformation, service mapping, service orchestration, transaction management, and security.

#### A. Requirements of the SOA-Based Model for POM

Requirements for SOA-Based model for POM need to be defined ahead of presenting the proposed model. To overcome the shortcomings found in the current model of POM, the following requirements must be satisfied:

- The connectivity and accessibility of POM should be based on specific standard connectivity that supports interoperability. We need compatible standard protocols such as SOAP, WSDL, and XML.
- Business processes requirement. We need a standard that achieves collaboration between services of POM in which a primary service directly invokes other services.
- The POM model should include integration to back-end systems of POM and support composition of services.
- Management requirement for the Web services of POM sections makes it necessary to monitor and manages them for availability. We need suitable and manageable integration infrastructure for Web services that serve the proposed model.
- The work flow management should be assured for building the model because several activities needed to implement across this requirement that controls service invocation and supports business processes of POM and supports its workflow logic.
- Accessibility and reachability. The POM model should allow customers an easy access through the Internet front end interface.
- Monitoring and Management in POM environment needs a new approach (such ESB) that supports monitoring and managing errors and faults that occur in services of POM applications.

#### B. SOA-Based POM Model Structure

To realize the requirements discussed above, different components are presented that constitute the proposed model. Each component satisfies one or more of the requirements and hence collectively leads to the achievement of the goals of the model. The proposed model based on SOA, Web services and ESB which allow interoperability and manageability is shown in Figure 3.

The proposed model mainly consists of the following components:

1. *The Enterprise Service Bus*: is considered as one important component of the proposed model. It plays the role of integration between different services, and is considered as the middleware support of SOA. It solves problems of interoperability during service module calling to better serve POM application and its sections. ESB is a method to manage services and allows customers to access the POM services over the Internet thus achieves connectivity and accessibility requirement of the model.

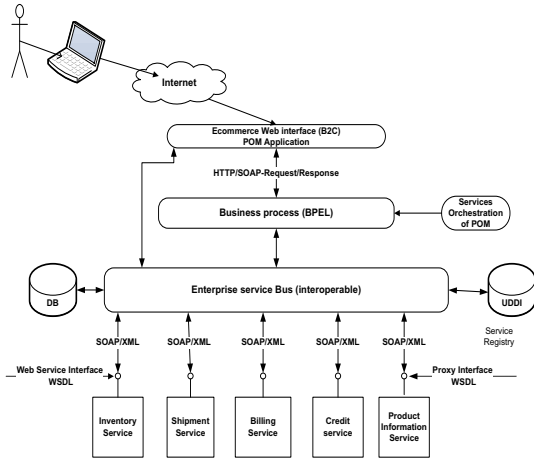

**Figure 3: Proposed SOA-Based Model**

2. **Service Registry:** is used to provide a controlled point of access for services metadata for all services provided by POM section. This registry is based on UDDI standard which provides details on how to publish and locate information about POM Web services.
3. **Database:** is important for storing the required information needed for building the Website or the portal of B2C that consumer interacts with. The client requests data about products or services from the portal of B2C. This component achieves accessibility and reachability requirement for the model.
4. **Core Services of POM:** includes Inventory service, Billing service, Shipment service, Credit service, and Product Information service. These core services realize and manage the POM that configures and serves to order product and provides information about product price and availability. Product Information service returns all related information about a product as part of POM. It accesses the required information from the database, the Inventory service determines whether there is sufficient inventory of each product to complete a purchase order. The Credit service checks and determines whether there are sufficient credits. The shipment service provides the cost of agent shipping the product to specific address of customer. The Billing service generates bills according to approved policies of Credit service and Inventory service. Invoking these services as a composite service is done using BPEL which interacts directly with the POM and returns status of purchases product.
5. **Service Orchestration:** is important part of POM and usually implemented using BPEL. It is responsible for orchestrating business processes or sub business processes and manages composite services. The composite service is invoked by POM client and it in turn invokes and orchestrates different services of POM to achieve the requirement of the composite service.

### C. Interaction of SOA-Based POM Model

The interaction between the components of the model is done through the ESB which integrates the components. It routes, transports, and formats requests and responses of

the services, and provides service discovery through the registry.

The proposed model is intended to achieve its goals which are interoperability and manageability. Interoperability allows using diverse types of system components of POM like Sales, Shipment, Billing and Product Information. This may have different software, data structure and interfaces to exchange data. Interoperability is important because it allows for connecting all section of purchase order in a uniform way and the exchange of information between sections of purchase order successfully. Interoperability is achieved by having different IT systems interact so the automation of the business process is achieved.

Figure 4 is a scenario workflow based on the model and shows how the interaction in the model occurs between the business and the customer. This scenario has two sides: the customer side and the business side. The customer side is related to end users that access B2C portal of the E-Commerce system using a Web browser. The role of the customer is to use POM model for viewing product information, requesting the product of interest and purchasing it by placing an order using POM application and sending the order to the business side and wait for a response. If the customer fills a valid order, the product will be sent to him with the invoice. Otherwise, he will receive error response.

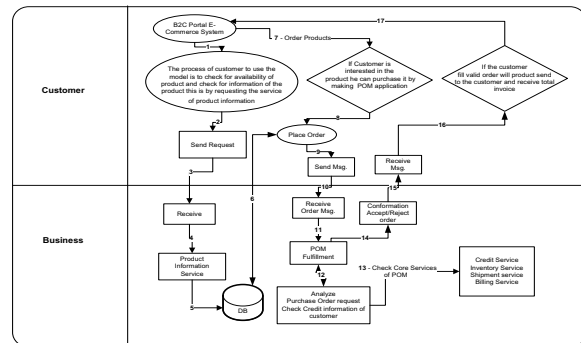

**Figure 4: Scenario Workflow Based on the Model**

On the business side, the POM application is deployed as different services in which customer can interact by browsing for products. One of these services is called Product Information service which receives all requests from the customer to retrieve the data and information of the product from the database. The other core services of POM at the business side track customer requests and fulfill order requests that realize and manage POM. Also they configure and serve the order request. Core POM services provide response to the customer about status of the customer's credit (Credit service) and status of items (Inventory service). If the POM order manipulated at the business side is valid, then a conformation of the total invoice is sent to the customer side.

### D. Case Study Implementation (Scenario Realization)

To provide a proof of concept of the proposed model, a case study is implemented. In this case study we present a bookstore as B2C E-Commerce system, and through the case study the model is validated to perform its

requirements. Briefly we summarize the bookstore as follows:

A bookstore presents the products (books) to the customer. The customer accesses the bookstore using a Web browser, browses information of specific books to request book order(s). This is done through the POM application which supports all activities of the POM section described below:

- Sales section checks with credit card section if credit is okay.
- Sales section checks with inventory section if the needed books are on the store.
- Sales section informs the billing section to bill the customer.
- Sales section informs the shipment section to send out the books.
- Shipment section sends the books to the customer.
- Shipment section informs the billing section to send the invoice.
- Billing section sends the invoice to the customer

#### E. High-Level of the Case Study Description

Figure 5 shows high-level runtime view of the case study. The customer accesses the system using a Web browser. The Customer checks the product (book) information such as author name, price, publisher etc.

After the customer accesses and views product information, he places his purchase order. POM tracking request is processed by interacting with the model over Web services interfaces. Formulating a request handled by Web services. The function available in the front end interface as consumer Web site accesses the POM application which interacts with the other five services to fulfill order request. The Querying of the database will create an answer and sends it to the client using SOAP messages such as XML document as data transport format. The use of Web services technology allows the separation of independent components, each with its own functionality and acting simultaneously in order to realize the main functionality of the model.

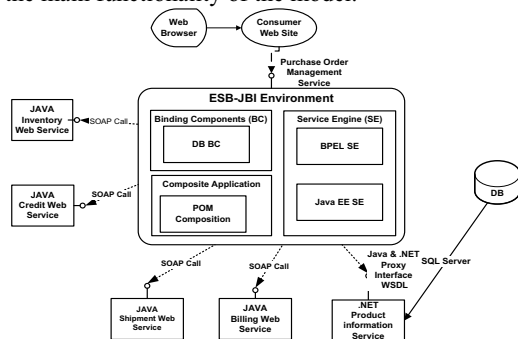

**Figure 5: Structure the Case Study**

The case study of the model is based on two different platforms, namely, Java NetBeans and Microsoft .NET. NetBeans platform runs in context of Java Business Integration (JBI) which is the realization of ESB. The NetBeans platform is used as an environment for the management integration component that realizes the interoperability and manageability of Web services. The

ESB allows connected applications with disparate technology and data formatting requirements to interoperate as service users and providers. The JBI based ESB provides integration based on an open source standards (OpenESB) is strongly linked with the NetBeans. The JBI is suitable enabler for SOA because it defines ESB architecture that contains BPEL Service Engine, HTTP Binding Component, Java EE Service Engine, Data Base Binding, and composite application for POM Services.

The implemented Java POM services are four services: Credit Card Service (*CreditWS*), Inventory Service (*InventoryWS*), Shipment Service (*ShipmentWS*), and Billing Service (*BillingWS*). The interaction between Web services over HTTP Binding Component can be used in a composite application. Therefore a single HTTP Binding Component acts as both a service provider and a service consumer.

The JavaEE Service Engine acts as a bridge between the application server and the JBI runtime environment, facilitating interaction between JavaEE and JBI components. The .NET platform runs in the context of Microsoft ASP.NET applications, the fifth service is Book Information Service (*BookInfoService*) implemented using .NET with C#. This service can access information stored in the data access layer using SQL Server.

#### F. Usage Scenario

To further illustrate the idea presented in this section. Figure 6 depicts interoperability usage scenario of the proposed model and illustrates how Web services can be used with different systems and the ability of these systems to interact and invoke interoperable services. The interaction is as follows:

1. The end user – e.g. customer would like to browse the B2C E-Commerce system of Web client as a book shop. This Web client contains books and a customer can view information of any book such as author name or price. In fact the customer browses the client side Web Client.
2. The Web client B2C Interface of book shop uses a client-side scripting language like JSP, taking the parameters entered in a SOAP message. The format of a SOAP message is defined in the WSDL description.
3. The WS-Client of book information running at client side uses and send SOAP messages over HTTP binding component to invoke the .NET book info operation which is part of the BookInfoWS.
4. The .Net service calls the C# implementation methods which are Data Access Layer (DAL) classes to interact with the Database (DB) created using MS SQL Server.
5. The .Net BookInfoWS accesses the database at the SQL Server.
6. The database returns the requested book record to the implementation method.
7. The implementation method returns the response to the .Net Service BookInfoWS.
8. The .Net service manipulates the result and returns to the SOAP client which returns the result of requested book B2C Interface of book shop.
9. The bookshop store returns information of requested book to the customer.

10. If the customer is interested in the requested book he purchases it.
11. In this case the business of book shop offers the customer a purchase order management application (POM Services) in client side. In this stage Web client, B2C Interface of book shop is using a client-side scripting language like JSP, taking the purchase order information entered into the Web form and packaging it into a SOAP message. The format of the SOAP message is defined in the WSDL description.

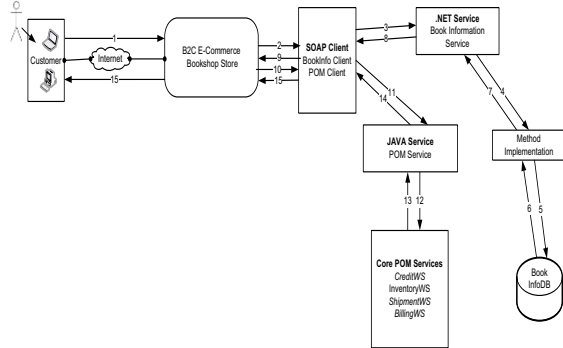
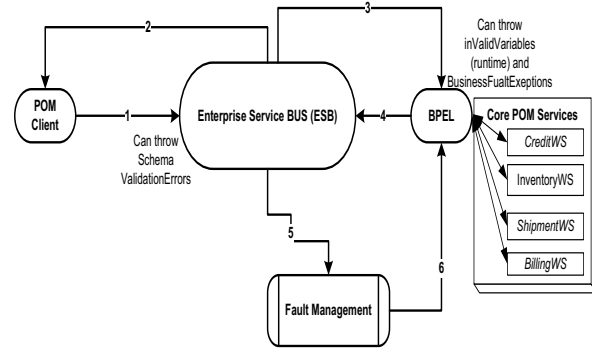

**Figure 6: Interoperability Usage Scenario**

12. The SOAP message is sent to the POM services endpoint hosted by the HTTP binding component. Then this message is sent to the OpenESB BPEL Service Engine to interpret the purchase order information and properly invokes other BPEL processes to fulfill the request. The OpenESB BPEL Service Engine creates a response message of checking and orchestrating the four services (credit checking, inventory checking, shipment, and billing).
13. The response message sends over HTTP binding component to the POM services and converts it to a SOAP message.
14. The SOAP message is sent back to the Web service client of POM as a proper response as defined by the WSDL.
15. The Web service client takes the response and creates a human-readable HTML page with JSP scripting language to inform the customer whether the purchase order was accepted or rejected. If the order is accepted it will return the Billing of item purchased. If the order is rejected it will return error report due to the checking of credit and inventory error, e.g., credit has insufficient amount.

Figure 7 depicts manageability usage scenario on how to handle runtime and business faults, in case of synchronous and asynchronous requests that occur through the model.

1. The POM client sends a one-way synchronous request message through ESB.
2. If the ESB detects invalid XML message (schema validation) runtime exception is directly returned to the POM client.
3. The ESB sends a request to BPEL process through routing rule. This is equivalent to stating an asynchronous process.



**Figure 7: Manageability Usage Scenario**

4. BPEL exceptions (both runtime and business faults) are sent to ESB.
5. The exceptions are handled as per policies defined in fault management defined in BPEL.
6. When faults are corrected through retry requests from client, control goes back to the component that raised the exception initially and request completes successfully.

The presented scenarios outline how the implemented case study fulfills the POM to achieve interoperability and manageability quality attributes.

The application of POM described in the scenario is designed to show and verify a certain level of manageability and interoperability between Web services implemented in different Web services environments. In these scenarios we connect the parts of POM together with two different environment platforms which are .NET and Java NetBeans. These different programming languages are interact with each other via Web services by sending and receiving SOAP messages formatted in XML over HTTP. The WSDL used to describe the interfaces of Web services offers a standardized format that fulfills interoperability.

For the quality attribute discussion, the interoperability achievement is clear in the scenario because the Web application, .NET service, and Java service are heterogeneous services. The scenario setup the Web services based communication between .NET Web services and Java NetBeans. The Web service is based on delivered messages between these languages and using database. The interoperability also is achieved by using standards connectivity such as XML, SOAP, and WSDL that achieve interoperable integration between different services of POM application. The manageability is achieved by using ESB middleware that manages Web services of POM model. It allows managing data and transformation of messages between the services of POM model. The ESB provides support for use orchestration using BPEL which is responsible for managing composite services of POM.

Furthermore the ESB is responsible for managing and monitoring using BPEL that provides and handles the recover fault that can occur in business logic of Web services of POM model.



## CONCLUSION

Nowadays, E-Commerce systems are characterized by complex Web applications that use different operating systems and technologies and have to face constant changes imposed by technological evolution. POM is a core part of E-Commerce environment that is used in B2C and B2B categories of E-Commerce. In many cases POM components use integration approaches that lack interoperability and manageability features. In this paper a technical model of POM E-Commerce system was presented and analyzed. A new POM model based on SOA solution was proposed that overcomes the shortcoming of the currently used model that lacks interoperability and manageability. The main contribution of this paper is to align SOA-based model to the B2C and B2B E-Commerce domain.

Future research efforts can be directed towards the realization of the proposed model and the challenges that face its realization, as well as to extend this work the integration of business interaction and semantic Web can be adapted and used to enhance the interoperability of the model. The model did not address features that can enhance flexibility and dependability such as service auto-composition. Also the model can be enhanced by adding the security feature.

Finally we recommend evaluating the performance as it may affect the services of POM application and the environment using the SOA-based model.

## REFERENCES

- [1] Alonso, G., F. Casati, et al., *Web Services: Concepts, Architectures and Applications*. Berlin: Springer, 2004.
- [2] Arba, R., "Using SOA for E-Commerce Systems and Development," in *Proceedings of The International Conference on Knowledge Engineering KEPT2009* Cluj-Napoca, (Romania), 2009, pp. 3-6.
- [3] Baraka, R. S. and S. M. Madoukh, "A Conceptual SOA-Based Framework for e-Government Central Database," in *Computer, Information and Telecommunication Systems (CITS), 2012 International Conference*, Amman, 2012.
- [4] Baumeister, H. (2011). *Software Development of Web Services (Technical University of Denmark ed.)*. Available:-<http://www2.imm.dtu.dk/courses/02267/>  
<http://www2.imm.dtu.dk/courses/02267/index15.html>
- [5] Booth, D., H. Haas, et al. (2004). *Web Services Architecture* Available: <http://www.w3.org/TR/ws-arch/>
- [6] Chen, M., A. N. K. Chen, et al., "Implications and Impacts of Web Services to Electronic Commerce Research and Practices," *Journal of Electronic Commerce Research*, vol. 4, pp. 128- 139, 2003.
- [7] Curl, A. and K. Fertalj, "A Review of Enterprise IT Integration Methods," in *Proceedings of the 31st International Conference on Information Technology Interfaces (ITI '09)* pp.107-112., Dubrovnik, 2009, pp. 107-112.
- [8] Damodaran, S., "RosettaNet: Adoption Brings New Problems, New Solutions," in *Proceedings of the XML 2005 Conference*, Atlanta, USA, 2005, pp. 1-14.
- [9] Haller, A., P. Kotinurmi, et al., "Handling Hetrogeneity In RosettaNet Messages," in *Proceedings of the 22nd Annual ACM Symposium on Applied Computing (SAC)*, Seoul, Korea, 2007.
- [10] Mohamed, U. A., G. H. Galal-Edeen, et al., "Building Integrated Oil and Gas B2B E-Commerce Hub Architecture Based on SOA," in *Proceedings of International Conference on E-Education, E-Business, E-Management and E-Learning (IC4E)*, 2010, pp. 599-608.
- [11] NISO, "Understanding Metadata," ed: NISO Press, 2004
- [12] Papazoglou, M. and W. J. Heuvel, "Service Oriented Architectures: Approaches, Technologies and Research Issues," *VLDB Journal* vol. 16, pp. 389-415, 2007.
- [13] Papazoglou, M., P. Traverso, et al., "Service-Oriented Computing Research Roadmap," *International Journal of Cooperative Information Systems*, vol. 17, pp. 223-255, 2008.
- [14] Petritsch, H. (2006). *Service-Oriented Architecture (SOA) vs. Component Based Architecture*. Available:  
[http://petritsch.co.at/download/SOA\\_vs\\_component\\_based.pdf](http://petritsch.co.at/download/SOA_vs_component_based.pdf)
- [15] Rademakers, T. and J. Dirksen, *Open Source ESB in Action, Example Implementations in Mule and ServiceMIX*: Manning Publisher, 2008.
- [16] Ryman, A. (2003). *Understanding Web Services*. Available:  
[http://www.ibm.com/developerworks/websphere/library/techarticles/0307\\_ryman/ryman.html](http://www.ibm.com/developerworks/websphere/library/techarticles/0307_ryman/ryman.html)
- [17]Shim, S., V. Pendyala, et al., "Business-to-Business E-Commerce Frameworks," *IEEE Computer Society* vol. 33, pp. 40-47, 2000.
- [18] Trastour, D., C. Preist, et al., "Using Semantic Web Technology to Enhance Current Business-to-Business Integration Approaches," in *Proceedings of the 7th International Conference on Enterprise Distributed Object Computing (EDOC)*, 2003, pp. 222-231.
- [19] Turban, E., D. King, et al., *Electronic Commerce 2006: a Managerial Perspective*: Pearson Prentice Hall, 2006.
- [20] Xiong-yi, L., "Research and Application of SOA in B2B Electronic Commerce," in *International Conference On Computer Technology and Development (ICCTD)* 2009, pp. 649-653.