

SOLID STATE HIGH POWER RF SYSTEM FOR SUPERCONDUCTING CAVITIES

A.A. Zavadtsev¹, D.A. Zavadtsev¹, L.V. Kravchuk², S.V. Kutsaev¹

¹Nano Invest, Reutov, Russia;

²Institute for Nuclear Research of RAS, 117312, Moscow, Russia

E-mail: azavadtsev@yandex.ru

Solid State High Power RF System is proposed for XFEL and ILC. It includes individual RF power supply for each SC cavity and common control system. Each RF power supply includes Solid State Generator, circulator and Q-tuner. Triggering, synchronization, output power and phase of each Solid State Generator are controlled from the common control system through fiber-optic lines. Main parameters of Solid State Generator are: frequency 1.3 GHz, peak power 128 kW, pulse length 1.4 msec, repetition rate 10 Hz, average power 1.8 kW, CW power 2.5 kW. Advantages of Solid State High Power RF System are: simple triggering, synchronization, output power and phase adjustment for all cavities separately, operation both in pulse and in CW modes, unlimited lifetime, no high voltage, no oil-tank, compactness.

PACS: 29.17.+w:85.25.-j

1. INTRODUCTION

RF power supply system for superconducting (SC) accelerating cavities of European XFEL [1] and International Linear Collider (ILC) [2] are based on high peak power klystrons. RF power from the klystron is distributed between the cavities through complicate waveguide RF power distribution system. The XFEL waveguide RF power distribution system is shown in Fig.1 [1]. RF power from one klystron is divided between 32 cavities in 4 cryomodules.

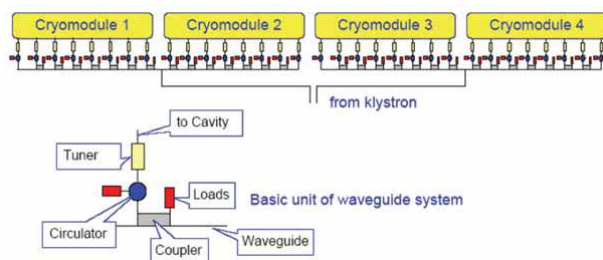

Fig.1. RF waveguide distribution of klystron based XFEL RF station

So there is the first problem to create high peak RF power using complicate multi-beam klystrons and high power modulators and the second problem to distribute this peak RF power between many cavities.

A development of solid state components during last years allows us to consider another approach to creation of RF power supply system to feed SC cavities in linear accelerators. Solid state high power RF system developed for XFEL and ILC accelerators includes individual RF power supply for each SC cavity and common control&synchronization system.

2. COMPONENT SET

Each RF power supply includes Solid State Generator, ferrite circulator and Q-tuner.

Solid State Generator consists of following parts: LLRF (32 W output); eight amplifier units (sixteen 1 kW outputs); eight 16-channel air-isolated water-cooled strip line RF power adders (16 kW output); 8-channel waveguide RF power adder (128 kW output); PLC; 50 V DC, 6 kW power supply.

3. MAIN PARAMETERS

Main parameters of Solid State Generator are shown in Table 1.

Table 1

Main parameters of Solid State Generator

Parameter	Units	Value
Operating frequency	MHz	1300
Peak power	kW	128
Pulse length	msec	1.4
Pulse repetition rate	Hz	10
Synchronization frequency	MHz	10
Average power	kW	1.8
CW power	kW	2.5
Output waveguide port		WR650
Feeding line	V/kW/ph/Hz	400/6/3/50

Most input couplers for SC cavity include coaxial antenna, coaxial line and waveguide to coaxial transition, needed to connect to the klystron with waveguide output port. In case of solid state RF generator 8-channel waveguide RF power adder can be changed by 8-channel strip line (or coaxial) RF power adder with coaxial output port. It allows to use coaxial input coupler for SC cavity without waveguide to coaxial transition with coaxial input port.

4. LLRF

Low level RF power supply (LLRF) includes: master-generator; RF switch; vector-modulator; pre-amplifier.

Input 10 MHz synchronization signal comes to the master-generator through fiber-optic line from common control system. Output frequency of the master-generator is 1300 MHz.

RF switch forms 1.4 msec 10 Hz pulses.

The vector-modulator allows to control amplitude and phase of RF power at the cavity input.

RF power at the three stage pre-amplifier output is 32 W. This power is divided by 8 and passes to the inputs of 8 amplifier units.

Triggering, synchronization, output power and phase of each Solid State Generator are controlled from the common control system through fiber-optic lines.

5. AMPLIFIER UNIT

Each amplifier unit includes seventeen 1 kW amplifiers: 16 amplifiers for 16 output channels, one the same amplifier as a pre-amplifier for first 16 amplifiers and one-transistor 62 W amplifier stage. The amplifier unit has one 4 W input and sixteen 1 kW outputs.

Each 1 kW amplifier includes four 250 W transistors. The powers of these transistors are added to one coaxial line. Output RF power of the amplifier is 1 kW. Amplification gain is 12 dB. Input RF power is to be 62 W. The transistors are equipped with water-cooled sink. The whole amplifier is assembled on one PCB.

6. STRIP LINE RF POWER ADDER

Strip line RF power adder is to collect RF power from 16 amplifiers to one output line. It includes 15 strip line bridges. Strip line is air isolated. Strips are mounted in the water-cooled body through quarter wave length line pieces, allowing to fix the line and to cool it.

There are 16 strip line RF power adders in the Solid State Generator (see Fig.2).

7. WAVEGUIDE RF POWER ADDER

RF power from 16 strip line RF power adders comes through coaxial lines to 16 inputs of waveguide RF power adder, which includes 7 waveguide bridges. Each bridge is equipped with water-cooled waveguide load. The body of whole waveguide RF power adder is made of one Al piece (see Fig.3).

8. CONTROL

PLC based control system is used in Solid State Generator.

9. COOLING

Water-cooling of Solid State Generator is assumed.

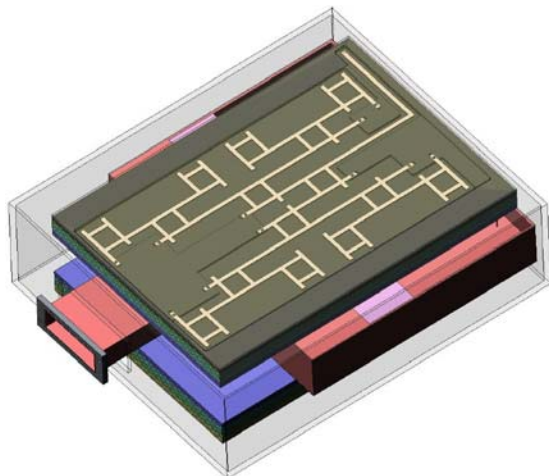

Fig.2. Strip line RF power adder

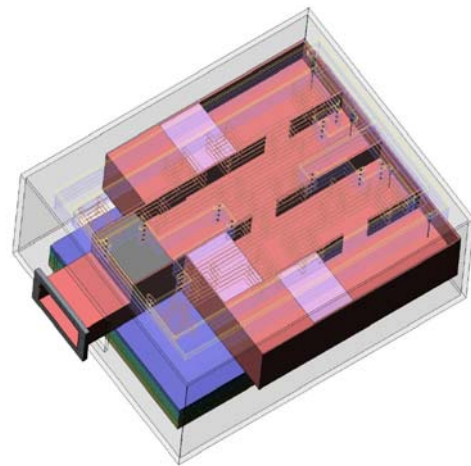

Fig.3. Waveguide RF power adder

10. ENGINEERING DESIGN AND EQUIPMENT LAYOUT

Fig.4 shows general view of the Solid State Generator. It includes 8 amplifier units, 8 strip line RF power adders and 1 waveguide RF power adder.

LLRF is assembled in separate unit. RF power at LLRF output is 32 W.

The layout of the solid state based equipment in XFEL tunnel is shown in Fig.5.

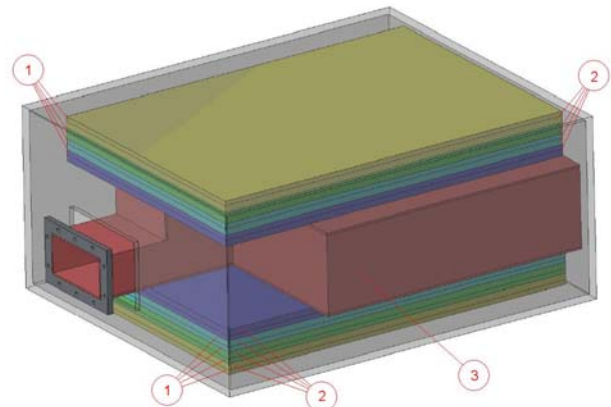

Fig.4. General view of Solid State Generator
1 is amplifier unit, 2 is strip line RF power adder,
3 is waveguide RF power adder

CONCLUSIONS

Comparison of the equipment for XFEL on base of the klystron [1] and solid state generator is shown in Table 2.

The tuner in TDR system is to adjust both loaded Q-factor and the phase. The tuner in Solid State High Power RF System is simpler. It is to adjust loaded Q-factor only.

Advantages of Solid State High Power RF System are:

Triggering, synchronization, output power and phase can be carried out separately for all cavities from control system through fiber-optic lines. This is very simple and reliable control way.

Adjustment of input RF power for all cavities is possible individually in contradiction to High Power RF System of XFEL TDR [1]. All cavities have different maximum accelerating gradient. TDR scheme allows us to have the same input power at all cavities (fed by the same klystron) and therefore to operate at low accelerat-

ing gradient corresponding to the maximum accelerating gradient of worst cavity. Solid State High Power RF System allows us to operate at maximum power in each cavity and therefore at higher total acceleration rate.

Table 2
Comparison of the equipment for XFEL on base of the klystron and solid state generator

Klystron RF System		Solid State RF System	
Unit	Qnt	Unit	Qnt
Modulator	29	Solid State Generator	928
Klystron	29	Circulator	928
Solenoid	29	Q-tuner	928
Directional coupler	812		
Load	812		
Circulator	928		
Tuner (phase & Q)	928		
Waveguide (~100 m)	29		
LLRF	29		
Solenoid power supply	29		
Klystron Ion pump power supply	29		
Waveguide gas filling system	29		

Solid State High Power RF System allows us to adjust loaded Q-factor by tuner and accelerating phase by vector-modulator of Solid State Generator separately, unlike by the same tuner as in High Power RF System of XFEL TDR.

Solid State High Power RF System allows us to operate in pulse mode as well as in CW mode as this is planned in Item #4.1.3.3 of XFEL TDR. This is enough only to choose operating mode (pulse/CW) in the interface of the control terminal.

ТВЕРДОТЕЛЬНАЯ СВЧ-СИСТЕМА ПИТАНИЯ ДЛЯ СВЕРХПРОВОДЯЩИХ РЕЗОНАТОРОВ

А.А. Завадцев, Д.А. Завадцев, Л.В. Кравчук, С.В. Куцаев

Предложен твердотельный вариант СВЧ-системы питания для проектов XFEL и ILC, включающий индивидуальный источник питания для каждого СП-резонатора и общую систему управления. Каждый источник питания содержит твердотельный генератор, циркулятор и систему подстройки добротности. Переключение, синхронизация, выходная мощность и фаза каждого твердотельного генератора контролируются общей системой управления по средствам оптоволоконного кабеля. Основные параметры твердотельного генератора: частота 1,3 ГГц, пиковая мощность 128 кВт, длина импульса 1,4 мс, частота повторения 10 Гц, средняя мощность 1,8 кВт, непрерывная мощность 2,5 кВт. Преимущества твердотельной СВЧ-системы питания: простые переключение и синхронизация, раздельная подстройка выходной мощности и фазы для каждого резонатора, возможность работы как в импульсном, так и в непрерывном режиме, неограниченный срок службы, отсутствие высокого напряжения и масляного бака, компактность

ТВЕРДОТІЛЬНА НВЧ-СИСТЕМА ЖИВЛЕННЯ ДЛЯ НАДПРОВІДНИХ РЕЗОНАТОРІВ

А.А. Завадцев, Д.А. Завадцев, Л.В. Кравчук, С.В. Куцаев

Запропоновано твердотільний варіант НВЧ-системи живлення для проектів XFEL і ILC, що включає індивідуальне джерело живлення для кожного НП-резонатора і загальну систему керування. Кожне джерело живлення містить твердотільний генератор, циркулятор і систему підстроювання добротності. Перемикання, синхронізація, вихідна потужність і фаза кожного твердотільного генератора контролюються загальною системою керування по засобах оптоволоконного кабелю. Основні параметри твердотільного генератора: частота 1,3 ГГц, пікова потужність 128 кВт, довжина імпульсу 1,4 мс, частота повторення 10 Гц, середня потужність 1,8 кВт, безперервна потужність 2,5 кВт. Переваги твердотільної НВЧ-системи живлення: прості перемикання і синхронізація, роздільне підстроювання вихідної потужності і фази для кожного резонатора, можливість роботи як в імпульсному, так і у безперервному режимі, необмежений термін служби, відсутність високої напруги і масляного бака, компактність.

Solid State High Power RF System has no limited lifetime practically after test and rejection of the transistors, unlike High Power RF System based on klystrons with limited lifetime.

Solid State High Power RF System is low voltage equipment, unlike klystron based High Power RF System having 100 kV modulators.

Solid State High Power RF System has no oil-tank.

Solid State High Power RF System is very simple and compact.

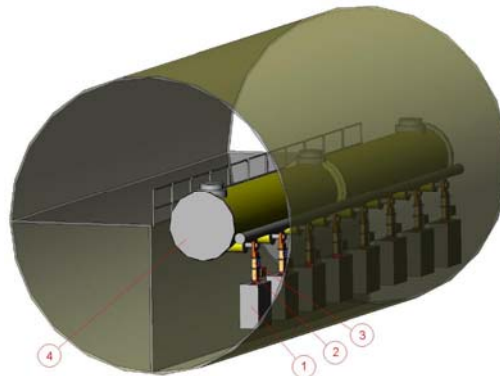

Fig. 5. Accelerator module with Solid State High Power RF System in XFEL tunnel.

1 is Solid State Generator, 2 is ferrite circulator, 3 is tuner, 4 is accelerator module

REFERENCES

1. The Technical Design Report of the European XFEL. <http://xfel.desy.de/tdr/tdr/>. DESY 2006-097. July 2007.
2. International Linear Collider. <http://www.linearcollider.org/cms/>.
3. A.Zavadtsev, D.Zavadtsev, et al. // Solid State High Power RF System for Superconducting Linacs // Proc. of PAC'09.

Статья поступила в редакцию 07.09.2009 г.