

MERLEWOOD RESEARCH AND DEVELOPMENT PAPER

No 90

THE EFFECT OF AFFORESTATION WITH SITKA SPRUCE ON SOIL
CARBON DYNAMICS AT GISBURN: A SIMPLE MODEL STUDY

by

BENT T CHRISTENSEN

Institute of Terrestrial Ecology
Merlewood Research Station
Grange-over-Sands
Cumbria
England
LA11 6JU

May 1982

MODEL CONSIDERATIONS

The dynamics of soil carbon may be described by mathematical models, which are more or less sophisticated. Jenkinson & Rayner (1977) have developed a promising model for soil organic matter dynamics in agricultural soils, but the paucity of data available in the present study prevents the use of their model. Instead, some simpler models have been applied. The conceptual framework in which the Gisburn pilot study was carried out is depicted in Figure 1. This model is based on the morphological appearance of the profiles at Gisburn and is in accordance with the normally adopted discrimination between forest floor and mineral soil horizons. It refers to a comparison between a stand of Sitka spruce immediately adjacent to the Gisburn experimental plots (see Christensen, 1982) and unplanted areas within the same experimental area. Sampling was as described in Christensen (1982).

The model consists of two compartments, the forest floor carbon pool (F), and the mineral soil carbon pool (A). The inputs to F are above-ground litter-fall (I) and below-ground inputs from roots (B_F). The outputs are controlled by the decomposition rate (k_1 , respiration) and the transfer rate (a) of humified organic matter from F to A. Thus the annual decomposition is k_1F and the annual transfer from F to A is aF , assuming that these processes are controlled by first order kinetics. Inputs to A consist of below-ground root input (B_A) and transfer of humified organic matter from F to A (aF). From A only one output, the decomposition rate (k_2), is considered. Assuming first order kinetics, the annual output from A becomes k_2A . The units used for F and A are kg C/m^2 , for inputs and outputs $\text{kg C/m}^2/\text{year}$, and for rates year^{-1} .

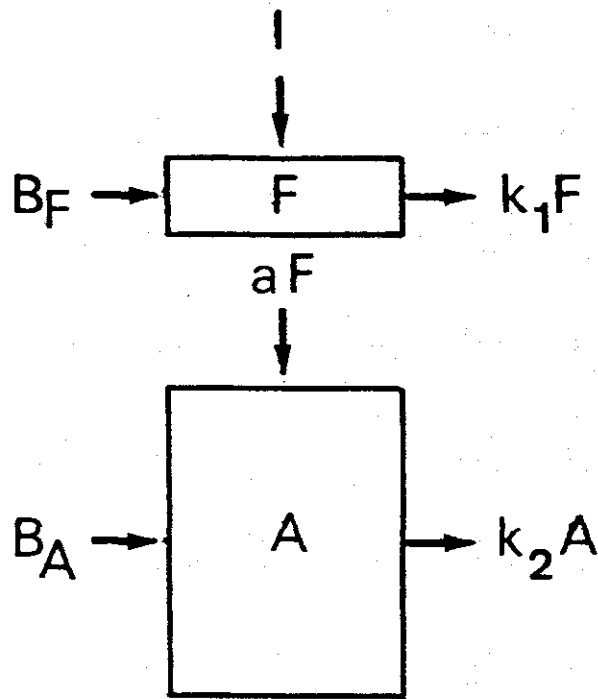

Figure 1. A two compartment model of the soil carbon dynamics at Gisburn (Model A).

Legend:

- I: aboveground input
- F: forest floor pool
- A: mineral soil pool
- B_F : belowground input to F
- B_A : belowground input to A
- a: transfer rate from F to A
- k_1 : decay rate of F
- k_2 : decay rate of A

The equations describing time-dependent changes in F and A are

$$(I) \frac{dF}{dt} = B_F + I - k_1 F - aF = B_F + I - (k_1 + a)F$$

$$(II) \frac{dA}{dt} = B_A + aF - k_2 A$$

This expression is called Model A.

A second model, called Model B, was applied too. Model B was taken from van Dijk (1980) and considers changes in the total soil carbon pool ($X = F + A$). The equation describing this model is

$$(III) \frac{dX}{dt} = r_1 (B + I) - r_2 X$$

where r_1 is the humification coefficient or the part of the organic matter input ($B + I$) remaining in the soil after one year, r_2 is the decomposition rate of all organic material after one year. Thus no discrimination between the degradability of "young" and "old" soil organic matter is made, B is the total below-ground input.

Finally, a third model was used (Model C). This model is the most simple as only one compartment is considered, and no discrimination between the different types of organic matter is made. The equation governing the change in time of the total soil organic matter pool is

$$(IV) \frac{dX}{dt} = I_T - kX$$

where X is the total organic matter pool ($F + A$)

I_T is the total input ($B + I$)

k is the overall decomposition rate

Model C was applied in order to test the sensitivity of the model output to changes in assumed and measured parameters. As both Model A and Model B

rest upon a number of more or less uncertain assumptions, this model is more easily applied to the actually measured values.

AVAILABLE DATA AND ASSUMPTIONS

In the present study the following values were actually measured assuming the Grass reference plot to represent the carbon pools before trees were planted:

F_0 : F at time $t = 0$ (forest floor carbon pool when trees were planted),
 $F_0 = 3.49 \text{ kg C/m}^2$

F_{25} : F at time $t = 25$ years (forest floor carbon pool under Sitka spruce 25 years after trees were planted), $F_{25} = 1.07 \text{ kg C/m}^2$

A_0 : A at time $t = 0$, $A_0 = 17.88 \text{ kg C/m}^2$

A_{25} : A at time $t = 25$, $A_{25} = 12.04 \text{ kg C/m}^2$

In a study of Sitka spruce planted 20 to 30 years ago on peaty gley/surface water gley soils in Northern Ireland, Adams *et al.* (1980) found that above-ground litterfall averaged $0.365 \text{ kg d.w./m}^2/\text{year}$. If a carbon content of 50% is adopted, then I becomes $0.180 \text{ kg C/m}^2/\text{year}$. This value has been used for litterfall in the Spruce stand at Gisburn.

The total annual root input to F and A is assumed to be 22% of above-ground litterfall (based on Fig. 4 of Miller, 1979). The root input to F is taken to equal root input to A, so $B_F = B_A = 0.020 \text{ kg C/m}^2/\text{year}$, as a similar root activity in F and A is assumed.

MODEL A

In order to cope with Model A, it was assumed that F has reached steady state after 25 years ($\frac{dF}{dt} = 0$). Equation (I) then is reduced to

$$(V) \cdot 0 = B_F + I - (k_1 + a)F$$

From (V) the total turnover rate ($k_1 + a$) of F is calculated to 0.187 year⁻¹, giving a turnover time of 5.35 years for F.

As the partition of the output from F between aF and k_1F is not known, further assumptions had to be made. It was assumed (based on Fig 2 of Minderman, 1968) that of a given I, 85% would be respired after 5 years in F and 15% would still be left in F. The proportion between a and k_1 was then taken to be $15 k_1 = 85 a$. Now a and k_1 can be calculated

$$k_1 + a = 0.187, \text{ and } k_1 = 0.159 \text{ and } a = 0.028$$

Equation (II) now becomes

$$(VI) \frac{dA}{dt} = 0.02 + (0.028 \times 1.07) - k_2 A = 0.05 - k_2 A$$

Integrating (VI) gives

$$A_t = \frac{0.05}{k_2} + (A_0 - \frac{0.05}{k_2}) e^{-k_2 t}$$

Inserting $A_0 = 17.88$ and $t = 25$

$$12.04 = \frac{0.05}{k_2} + (17.88 - \frac{0.05}{k_2}) e^{-k_2 25}$$

This equation is balanced when $k_2 = 0.019$. If k_2 is constant after the first period of 25 years, then $A_{100} = 4.9 \text{ kg C/m}^2$, and for t going towards infinity we get $A_{ss} = 2.6 \text{ kg C/m}^2$.

MODEL B

Integration of equation (III) gives

$$(VII) X_t = \frac{r_1 (B + I)}{r_2} (1 - e^{-r_2 t}) + X_0 e^{-r_2 t}$$

Inserting $(B + I) = 0.200$, $X_0 = 21.37$, $X_{25} = 13.11$

and assuming $r_1 = 0.5$ then (VII) becomes ($t = 25$)

$$13.01 = \frac{0.11}{r_2} (1 - e^{-r_2 25}) + 21.37 e^{-r_2 25}$$

This equation is balanced when $r_2 = 0.027$, and it follows that $X_{100} = 5.24 \text{ kg C/m}^2$. For t approaching infinity we have $X_{ss} = 4.07 \text{ kg C/m}^2$. The difference between the results obtained by Model A and Model B relates to the acceptance of a similar decay rate of root input B_A and the humified organic matter of A in Model A, and the use of only one decay parameter in Model B.

In equation (VII) the first term on the right hand side of the equation covers the humification and decomposition of the annual input, whereas the second term describes the decomposition of organic matter initially present. Comparing values obtained by Model B with values from Model A shows that Model B is more satisfactory in generating acceptable predictions of pool sizes at different points in time.

MODEL C

When equation (IV) is integrated it becomes

$$(VIII) \quad X_t = \frac{I_T}{k} + (X_0 - \frac{I_T}{k}) e^{-kt}$$

For $I_T = 0.220$, $X_0 = 21.37$, $X_{25} = 13.11$ and $t = 25$ we get

$$13.11 = \frac{0.220}{k} + (21.37 - \frac{0.220}{k}) e^{-25t}$$

Balance is achieved when $k = 0.033$. Consequently $X_{100} = 7.21$ and for t approaching infinity we have $X_{ss} = 6.67$. Model C, which is the simplest, is seen to generate the most tenable predictions for the evolution in total soil carbon pool, but it has a small content of biological implications.

As Model C relates more directly to actually measured values, its sensitivity towards changes in parameters was tested. The sensitivity was tested by comparing model output for $t = 25$ with observed values from the Gisburn plots, and by considering the generated steady state values (X_{ss}). Results from the test are shown in Table 1, and examples are shown in Figures 2, 3, and 4.

From Table 1 it was calculated that a 10% deviation in I_T creates a 2.8% deviation in X_{25} and a 10% deviation in X_{ss} . A 10% deviation in k results in a 4.6% deviation in X_{25} and a 10% deviation in X_{ss} . The relationship between variations in k and resulting variations in X do not quite follow a straight line, but for the present purpose such relationship was accepted. For X_0 a 10% deviation gives 7.5% deviation in X_{25} , but no deviation in X_{ss} ; whatever X_0 is chosen to be, the same steady state level will be reached for a given I_T and k . But what is more important in the present context, is the relatively high sensitivity towards changes in X_0 when X_{25} is to be predicted.

DISCUSSION

It has been assumed that the soil carbon pool of the Grass reference plot represents the conditions at Gisburn before tree-planting was carried out in 1955. This assumption involves acceptance of a steady state condition of the soil carbon pool in the Grass plot ($X_t = X_{ss} = 21.37 \text{ kg C/m}^2$).

Conditions for maintaining steady state are

$$I_T = 0.192 \text{ for } k = 0.009,$$

$$I_T = 0.214 \text{ for } k = 0.010,$$

$$I_T = 0.320 \text{ for } k = 0.015,$$

$$I_T = 0.427 \text{ for } k = 0.020$$

Table 1. Sensitivity test of Model C.

I_T	k	X_0	X_{25}	X_{ss}
0.100	0.030	20.5	11.4	3.3
0.150	-	-	12.3	5.0
0.160	-	-	12.5	5.3
0.170	-	-	12.7	5.7
0.180	-	-	12.9	6.0
0.190	-	-	13.0	6.3
0.200	-	-	13.2	6.7
0.180	0.020	20.5	16.0	9.0
-	0.021	-	15.6	8.6
-	0.022	-	15.3	8.2
-	0.023	-	15.0	7.8
-	0.024	-	14.6	7.5
-	0.025	-	14.3	7.2
-	0.026	-	14.0	6.9
-	0.030	-	12.8	6.0
0.180	0.030	16.0	10.7	6.0
-	-	17.0	11.2	6.0
-	-	18.0	11.7	6.0
-	-	19.0	12.1	6.0
-	-	20.0	12.6	6.0
-	-	21.0	13.1	6.0
-	-	22.0	13.6	6.0
-	-	23.0	14.0	6.0

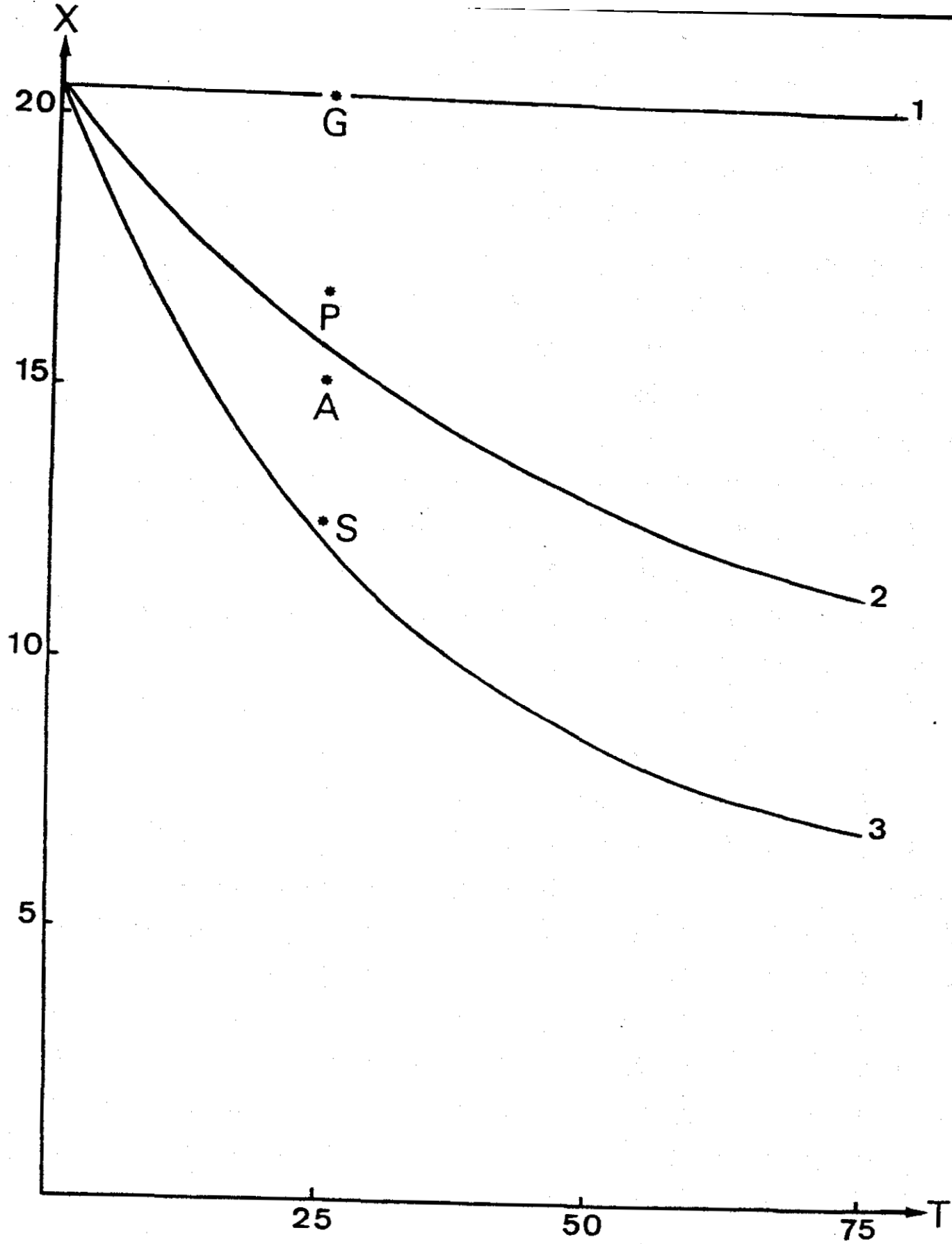

Figure 2. Model C: Changes in total soil carbon X (kg C/m^2) as a function of time T (years), when different decay rates are used (1: $k = 0.01$, 2: $k = 0.02$, 3: $k = 0.03$).
 * indicates values measured at Gisburn
 (G = Grass, P = Pine, A = Alder, S = Spruce). $X_0 = 20.5$, $I_T = 0.20$.

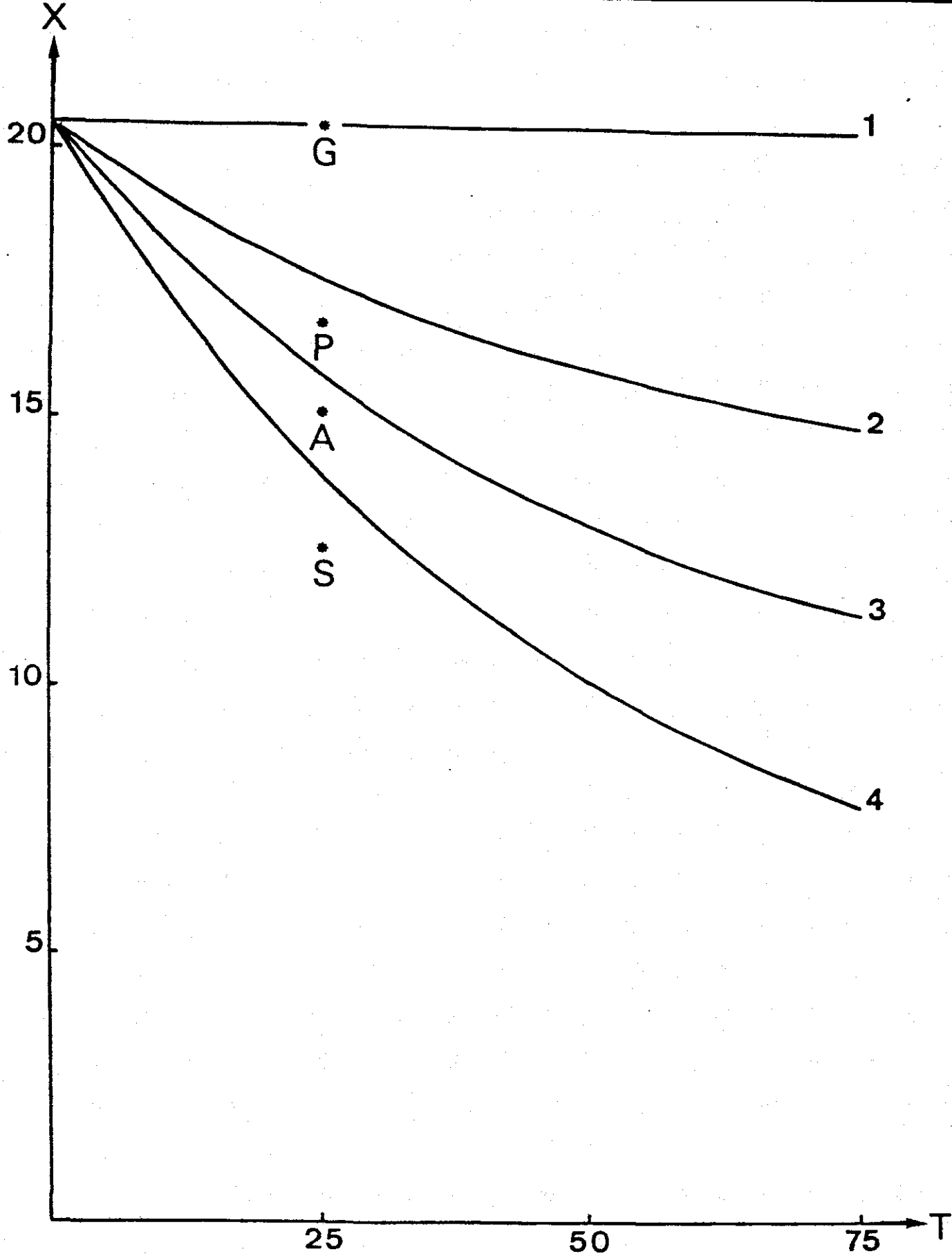

Figure 3. Model C: Changes in total soil carbon λ (kg C/m²) as a function time T (years), when different input values are used (1: $I_T = 0.41$, 2: $I_T = 0.30$, 3: $I_T = 0.20$, 4: $I_T = 0.10$). $X_0 = 20.5$, $k = 0.02$ (Further legend as Fig. 2).

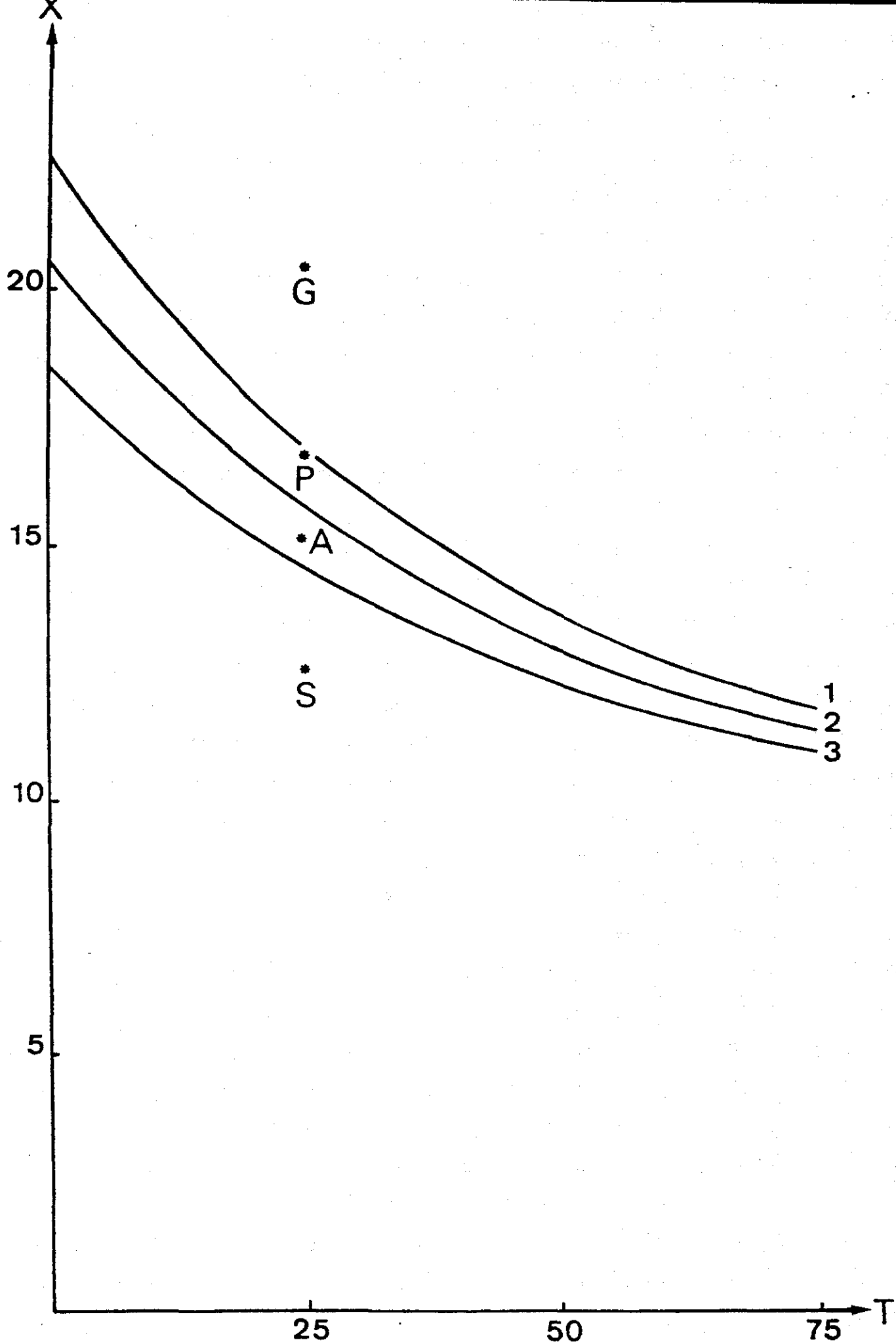

Figure 4: Model C: Changes in total soil carbon X (kg C/m²) as a function of time T (years), when different initial pool sizes are used (1: $X_0 = 22.5$, 2: $X_0 = 20.5$, 3: $X_0 = 18.5$) $k = 0.02$, $l_T = 0.20$. (Further legend as Fig. 2).

If similar inputs to the Grass plot and afforested plots are accepted, the turnover rate k is close to 0.010, which is considerably lower than k estimated for Sitka Spruce using Model C ($k = 0.033$).

When using Model A it was assumed that F has reached a steady state level after 25 years. Based on this assumption the overall output rate from F , $(a + k_1)$, was calculated to 0.187 year⁻¹. If this assumption is justified the following equation should be balanced (Model C used for the F-compartment).

$$F_T = \frac{I + B_F}{a + k_1} + (F_0 - \frac{I + B_F}{a + k_1}) e^{-(a+k_1)t}$$

or

$$F_{ss} = F_{25} = \frac{0.200}{0.187} + (3.49 - \frac{0.200}{0.187}) e^{-(0.187)25}$$

The model produces $F_{25} = 1.09$, which is close to $F_{ss} = 1.07$. If $(a+k_1)$ is 0.190 then $F_{25} = F_{ss} = 1.07$. The assumption adopted in using Model A thus seems justified. The turnover time, $(a+k_1)^{-1} = 5.35$ years for F is in accordance with Adams *et al.* (1980), who found a turnover time of 5.6 years for the forest floor of Sitka Spruce on similar soils. In their study root inputs were not considered; inclusion of this input will lower their estimate.

In spite of the good agreement obtained between measured and calculated values for F_{25} , k_1 is probably a function of time and not a constant figure. For North American Douglas-fir stands of varying age, Edmonds (1979) found that decomposition rates, determined by litter-bag techniques and by litter-fall/forest floor ratios, changed with stand-age.

For Sitka Spruce growing on peaty gley/surface water gley soils, Adams (1974) found that mean weight of oven-dry material, pH and content of several nutrients changed with stand age, although there was no evidence of a massive build-up of organic matter in the forest floor.

The figures for A_{100} and A_{ss} (4.9 and 2.6 respectively) generated by Model A seem untenable. First of all they far exceed the maximum stand age to be expected at the Gisburn site, and secondly the assumption of an equal decomposition rate of root input (B_A) and of humified organic matter in A is not realistic. In the third place k_2 probably is a function of time (stand age).

Predictions of pool sizes X_{100} and X_{ss} generated by Model B and Model C seem more acceptable. In these models X_{ss} will be reached faster than in Model A (measured by the difference between X_{100} and X_{ss}), but still the time-span needed to reach X_{ss} far exceeds the expected maximum stand age.

When k values for the Grass reference plot and the Spruce plot (both generated by Model C) are compared, it is seen that afforestation with Spruce accelerates the decomposition of the the total soil carbon pool by a factor 3, thereby reducing the turnover time $\frac{1}{k}$, from 100 years ($1/0.010$) before afforestation to 30 years ($1/0.033$) after.

None of the three models tested in the present study are quite satisfactory. For Model B and C it is recognized that they rest upon crude assumptions not justified by current knowledge of decomposition processes. The model containing the highest amount of biological implications is Model A. More accurate predictions of the soil carbon dynamics at Gisburn due to afforestation must await more direct measurements of the transfer of humified organic matter from F to A and better estimates of litter-fall and root inputs. But from the sensitivity test carried out by Model C an accurate estimate of soil carbon pools seems important too.

REFERENCES

- ADAMS, S.N. 1974. Some relations between forest litter and growth of Sitka spruce on poorly drained soils. *J. appl. Ecol.*, 11, 761-765.
- ADAMS, S.N., DICKSON, E.L. & QUINN, C. 1980. The amount and nutrient content of litter fall under Sitka spruce on poorly drained soils. *Forestry*, 53, 65-70.
- CHRISTENSEN, B.T. 1982. The effect of afforestation on carbon and nitrogen in the soil at Gisburn: a pilot study. (Merlewood research and development paper no. 89). Grange-over-Sands: Institute of Terrestrial Ecology.
- EDMONDS, R.L. 1979. Decomposition and nutrient release in Douglas-fir needle litter in relation to stand development. *Can. J. For. Res.*, 9, 132-140.
- JENKINSON, D.S. & RAYNER, J.H. 1977. The turnover of soil organic matter in some of the Rothamsted classical experiments. *Soil Sci.*, 123, 298-305.
- MILLER, H.G. 1979. The nutrient budgets of even-aged forests. In: *The ecology of even-aged forest plantations*, edited by E.D. Ford, D.C. Malcolm & J. Atterson, 221-256. Cambridge: Institute of Terrestrial Ecology.
- MINDERMAN, G. 1968. Addition, decomposition and accumulation of organic matter in forests. *J. Ecol.*, 56, 355-362.
- VAN DIJK, H. In Press. Survey of Dutch soil organic matter research with regard to humification and degradation rates in arable soils. To be published in: *Proc. EEC Land use and rural resources management committee*, 13-18 Oct. 1980, Wageningen.