



Title	Realization of three-port spring networks with inerter for effective mechanical control
Author(s)	Chen, MZ; WANG, K; Zou, Y; Chen, G
Citation	IEEE Transactions on Automatic Control, 2015
Issued Date	2015
URL	http://hdl.handle.net/10722/217091
Rights	Creative Commons: Attribution 3.0 Hong Kong License

Realization of Three-port Spring Networks with Inerter for Effective Mechanical Control

Michael Z. Q. Chen, Kai Wang, Yun Zou, and Guanrong Chen

Abstract—This note is concerned with the passive network synthesis problem of one-port networks consisting of one inerter, one damper, and at most three springs. To solve the problem, a necessary and sufficient condition is first derived for the realization of a three-port resistive network containing at most three elements, utilizing graph theory and several existing results of n -port resistive networks. By extracting the damper and the inerter, a necessary and sufficient condition is obtained for the realization of one-port networks containing one damper, one inerter, and at most three springs under an assumption that the admittance of three-port networks containing only springs is well-defined. The covering networks are also presented. Based on properties of circuit topology, a realizability condition is derived for the special case when the earlier assumption does not hold. Combining the two conditions when the assumption holds or not, the final realizability condition is obtained.

Keywords: Passive network synthesis, mechanical network, inerter, positive-real function, three-port resistive network.

I. INTRODUCTION

Passive network synthesis has been an important branch of systems theory, which experienced a “golden era” from the 1930s to the 1970s with a vast volume of literature available today [1], [11], [16]. However, there are still many problems remaining unsolved. For instance, the general realization methods such as the Bott-Duffin procedure [1] appear to be highly non-minimal. Up to now, the minimal realization problem is still far from being solved.

Recently, a new mechanical element named “inerter” [18] was introduced, where the force applied at its two terminals is proportional to the relative acceleration between them. Naturally, the inerter completes the force-current analogy between mechanical systems and electrical ones. Therefore, the theory of passive electrical network synthesis can be directly translated to the mechanical setting, making the design of passive mechanisms more systematic. Applications of the inerter to the control of mechanical systems [3], [17], [21], [22], [23] have been investigated, and performance advantages over conventional passive solutions have been demonstrated (see [4] for more details). Hence, interest in the theory of passive network synthesis has recently been well revived [2], [4]–[9], [12]–[14], [20]. In particular, there is an independent call for a renewed attempt by Kalman [15].

The present note is concerned with the “minimal” realization problem of one-port networks consisting of one damper,

M. Z. Q. Chen and K. Wang are with Department of Mechanical Engineering, The University of Hong Kong, Pokfulam Road, Hong Kong. (Correspondence: MZQ Chen, mzqchen@hku.hk.)

Y. Zou is with School of Automation, Nanjing University of Science and Technology, Nanjing, P. R. China.

G. Chen is with Department of Electronic Engineering, City University of Hong Kong, Tat Chee Avenue, Kowloon, Hong Kong.

This research was partially supported by the Hong Kong Research Grants Council under the GRF Grants 17200914 and CityU112014, the Innovation and Technology Commission under Grant ITS/178/13, and the Natural Science Foundation of China under Grant 61374053.

one inerter, and at most three springs. Motivated by higher cost and complexity of dampers and inerters, Chen and Smith in [6] solved the realizability problem with one damper, one inerter, and a finite number of springs, and showed that realization configurations can contain at most four springs. Considering the limitation of space and weight for passive mechanical systems, it is essential to further reduce the number of springs if ever possible. Foreseeably, combining the results obtained in this note, passive mechanical control using the inerter will become more effective for practical applications. Besides, the results can also contribute to the development of minimal realizations in general.

In this note, by making use of graph theory and the existing results on n -port resistive networks, a necessary and sufficient condition (Theorem 1) will be derived for a third-order symmetric matrix to be realizable as the admittance of three-port resistive networks containing at most three elements. Consequently, the result can be applied to the derivation of a necessary and sufficient condition (Theorem 2) for the realization of one-port networks containing one inerter, one damper, and at most three springs, under the assumption that the three-port network consisting of only springs has a well-defined admittance. Furthermore, explicit covering configurations (Theorems 3 and 4) will be provided. Moreover, based on properties of the circuit topology, the realizability condition (Theorem 6), when the earlier assumption does not hold, will be derived. Combining all the results, the final integrated condition (Theorem 7) will be derived. Unlike [6], graph theory is utilized in a major portion of the discussion in this note, using which a significant result (Theorem 1) that can contribute to minimal realizations of three-port resistive networks is subsequently obtained.

II. REALIZABILITY CONDITIONS UNDER A PARTICULAR ASSUMPTION

A. Admittance Formulation

The admittance Y of mechanical networks is defined to relate the Laplace transformed forces \hat{F} to velocities \hat{V} as $\hat{F} = Y\hat{V}$ based on the force-current analogy (see [18]).

Recall that using the method of element extraction, any one-port mechanical network Q with one damper, one inerter, and at most three springs can be expressed in the form of [6, Fig. 5], where $b, c > 0$ and X consists of at most three springs. Along the same line of investigation, the following assumption is made in this section, and will be removed in Section III.

Assumption 1: The three-port network X consisting of only springs has a well-defined admittance.

The Laplace transformed forces and velocities for the ports of the network X are related by the following expression:

$$\begin{bmatrix} \hat{F}_1 \\ \hat{F}_2 \\ \hat{F}_3 \end{bmatrix} = \frac{1}{s} \begin{bmatrix} K_{11} & K_{12} & K_{13} \\ K_{12} & K_{22} & K_{23} \\ K_{13} & K_{23} & K_{33} \end{bmatrix} \begin{bmatrix} \hat{v}_1 \\ \hat{v}_2 \\ \hat{v}_3 \end{bmatrix} =: \frac{1}{s} K \begin{bmatrix} \hat{v}_1 \\ \hat{v}_2 \\ \hat{v}_3 \end{bmatrix},$$

where K is a real symmetric matrix and is necessarily non-negative definite [16] since X is passive. Together with the

terminal relations $\hat{F}_2 = -c\hat{v}_2$ and $\hat{F}_3 = -b\hat{v}_3$, one obtains the driving-point admittance of Q as

$$Y(s) = \frac{\hat{F}_1}{\hat{v}_1} = \frac{\alpha_3 s^3 + \alpha_2 s^2 + \alpha_1 s + \alpha_0}{s^4 + \beta_3 s^3 + \beta_2 s^2 + \beta_1 s}, \quad (1)$$

where $\alpha_3 = K_{11}$, $\alpha_2 = (1/c)(K_{11}K_{22} - K_{12}^2)$, $\alpha_1 = (1/b)(K_{11}K_{33} - K_{13}^2)$, $\alpha_0 = (1/(bc))\det(K)$, $\beta_3 = (1/c)K_{22}$, $\beta_2 = (1/b)K_{33}$, $\beta_1 = (1/(bc))(K_{22}K_{33} - K_{23}^2)$, and $b, c > 0$. Furthermore, according to the analogy to one-element-kind networks, it is obvious that $(1/s)K$ is realizable as the admittance of a network consisting of at most three springs if and only if K is the admittance of a three-port resistive network containing at most three elements, whose realizability condition will be derived below.

B. Three-Port Resistive Networks With At Most Three Elements

It is well known that any third-order real symmetric matrix

$$Y_N = \begin{bmatrix} y_{11} & y_{12} & y_{13} \\ y_{12} & y_{22} & y_{23} \\ y_{13} & y_{23} & y_{33} \end{bmatrix} \quad (2)$$

is realizable by a three-port resistive network if and only if Y_N is paramount [6], [19]. However, necessary and sufficient conditions for the realization of three-port resistive networks with at most three elements have not yet been found.

Now, the main result of this subsection is established.

Theorem 1: A third-order real symmetric matrix Y_N in the form of (2) can be realized as the admittance of a three-port resistive network with at most three elements if and only if one of the following two conditions holds:

1. $y_{12}y_{13}y_{23} \leq 0$, $y_{11} - |y_{12}| - |y_{13}| \geq 0$, $y_{22} - |y_{12}| - |y_{23}| \geq 0$, $y_{33} - |y_{13}| - |y_{23}| \geq 0$, and at least three of y_{12} , y_{13} , y_{23} , $(y_{11} - |y_{12}| - |y_{13}|)$, $(y_{22} - |y_{12}| - |y_{23}|)$, and $(y_{33} - |y_{13}| - |y_{23}|)$ are zero.
2. $y_{12}y_{13}y_{23} \geq 0$ and at least one of the following three conditions holds with at least three of the six inequality signs being equality: a) $-|y_{13}| \leq 0$, $|y_{13}| \leq |y_{12}| \leq y_{11}$, $|y_{13}| \leq |y_{23}| \leq y_{33}$, and $|y_{12}| + |y_{23}| - |y_{13}| \leq y_{22}$; b) $-|y_{12}| \leq 0$, $|y_{12}| \leq |y_{13}| \leq y_{11}$, $|y_{12}| \leq |y_{23}| \leq y_{22}$, and $|y_{13}| + |y_{23}| - |y_{12}| \leq y_{33}$; c) $-|y_{23}| \leq 0$, $|y_{23}| \leq |y_{12}| \leq y_{22}$, $|y_{23}| \leq |y_{13}| \leq y_{33}$, and $|y_{12}| + |y_{13}| - |y_{23}| \leq y_{11}$.

Proof: See [10] for details. ■

C. Realizability Conditions

To reduce the number of parameters to six, the following transformation will be used:

$$G := \begin{bmatrix} G_1 & G_4 & G_5 \\ G_4 & G_2 & G_6 \\ G_5 & G_6 & G_3 \end{bmatrix} = T \begin{bmatrix} K_{11} & K_{12} & K_{13} \\ K_{12} & K_{22} & K_{23} \\ K_{13} & K_{23} & K_{33} \end{bmatrix} T, \quad (3)$$

where $T = \text{diag}\{1, 1/\sqrt{c}, 1/\sqrt{b}\}$. Then, $Y(s)$ is equivalent to

$$Y(s) = \frac{G_1 s^3 + (G_1 G_2 - G_4^2) s^2 + (G_1 G_3 - G_5^2) s + \det(G)}{s(s^3 + G_2 s^2 + G_3 s + (G_2 G_3 - G_6^2))}. \quad (4)$$

Using Lemmas 1–3 (see Appendix A), the following theorem is obtained.

Theorem 2: A positive-real function $Y(s)$ is realizable as the driving-point admittance of a one-port network, consisting of one damper, one inerter, and at most three springs, and satisfying Assumption 1, if and only if $Y(s)$ can be written in the form of (4), where G as defined in (3) is non-negative definite and satisfies the conditions of Lemma 2 or Lemma 3.

Proof: It is proved by combining Lemmas 1–3. ■

D. Realization Configurations

Theorem 3: Consider a positive-real function $Y(s)$ in the form of (4), where G as defined in (3) is a non-negative definite matrix. If any first-order minor or second-order minor of G is zero, then $Y(s)$ can be realized as a series-parallel network consisting of at most three springs, one inerter, and one damper, through the *Foster Preamble* [2, pg. 19].

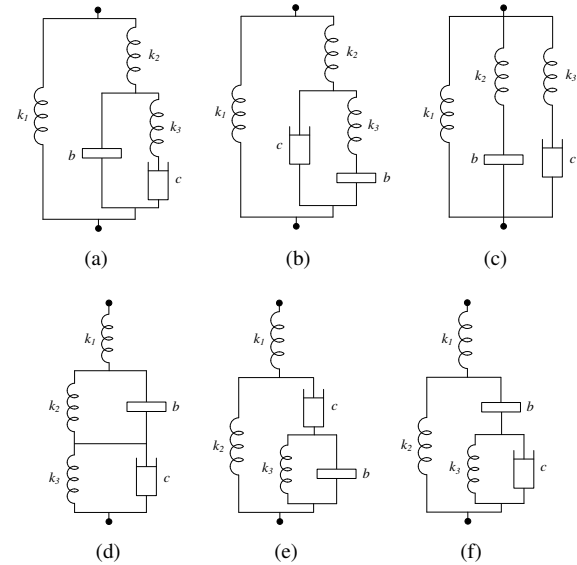

Fig. 1. The configurations covering the case when any first-order minor or second-order minor of G is zero, where the values of the elements are non-negative or infinity (corresponding to the element replaced by a short-circuit).

Proof: **Case 1:** $G_4 = 0$. One obtains

$$Y(s) = \frac{k_1}{s} + \left(\frac{s}{k_2} + \left(bs + \left(\frac{s}{k_3} + \frac{1}{c} \right)^{-1} \right)^{-1} \right)^{-1},$$

where $k_1 = \det(G)/(G_2 G_3 - G_6^2)$, $k_2 = G_2 G_5^2/(G_2 G_3 - G_6^2)$, $k_3 = G_2 G_5^2 G_6^2/(G_2 G_3 - G_6^2)^2$, $b = G_2^2 G_5^2/(G_2 G_3 - G_6^2)^2$, and $c = G_5^2 G_6^2/(G_2 G_3 - G_6^2)^2$. If $G_2 G_3 - G_6^2 \neq 0$, then $Y(s)$ is realizable as in Fig. 1(a) with $k_1, k_2, k_3, b, c \geq 0$. Specially, if $G_2 G_3 - G_6^2 = 0$, then $Y(s) = G_1/s$, which is realizable as in Fig. 1(a) with $k_1 = G_1 \geq 0$ and $k_2 = \infty$.

Case 2: $G_5 = 0$. One obtains

$$Y(s) = \frac{k_1}{s} + \left(\frac{s}{k_2} + \left(c + \left(\frac{s}{k_3} + \frac{1}{bs} \right)^{-1} \right)^{-1} \right)^{-1},$$

where $k_1 = \det(G)/(G_2 G_3 - G_6^2)$, $k_2 = G_3 G_4^2/(G_2 G_3 - G_6^2)$, $k_3 = G_3 G_4^2 G_6^2/(G_2 G_3 - G_6^2)^2$, $b = G_4^2 G_6^2/(G_2 G_3 - G_6^2)^2$,

and $c = G_3^2 G_4^2 / (G_2 G_3 - G_6^2)^2$. If $G_2 G_3 - G_6^2 \neq 0$, then $Y(s)$ is realizable as in Fig. 1(b) with $k_1, k_2, k_3, b, c \geq 0$. Specially, if $G_2 G_3 - G_6^2 = 0$, then $Y(s) = G_1/s$, which is realizable as in Fig. 1(b) with $k_1 = G_1 \geq 0$ and $k_2 = \infty$.

Case 3: $G_6 = 0$. One obtains

$$Y(s) = \frac{k_1}{s} + \left(\frac{s}{k_2} + \frac{1}{bs} \right)^{-1} + \left(\frac{s}{k_3} + \frac{1}{c} \right)^{-1},$$

where $k_1 = \det(G)/(G_2 G_3)$, $k_2 = G_5^2/G_3$, $k_3 = G_4^2/G_2$, $b = G_5^2/G_3^2$, and $c = G_4^2/G_2^2$. If $G_2 G_3 \neq 0$, then $Y(s)$ is realizable as in Fig. 1(c) with $k_1, k_2, k_3, b, c \geq 0$. Specially, if $G_2 = 0$ and $G_3 \neq 0$, then $Y(s) = (G_1 s^2 + (G_1 G_3 - G_5^2)/(s(s^2 + G_3)))/(G_3 s) = (G_1 G_3 - G_5^2)/(G_3 s) + 1/(G_3 s/G_5^2 + G_3^2/(G_5^2 s))$, which is realizable as in Fig. 1(c) with $k_1 = (G_1 G_3 - G_5^2)/G_3 \geq 0$, $k_2 = G_5^2/G_3 \geq 0$, $b = G_5^2/G_3^2 \geq 0$, and $k_3 = \infty$; if $G_3 = 0$ and $G_2 \neq 0$, then $Y(s) = (G_1 s + (G_1 G_2 - G_4^2)/(s(s + G_2)))/(G_2 s) = (G_1 G_2 - G_4^2)/(G_2 s) + 1/(G_2 s/G_4^2 + G_2^2/G_4^2)$, which is realizable as in Fig. 1(c) with $k_1 = (G_1 G_2 - G_4^2)/(G_2 s) \geq 0$, $k_3 = G_4^2/G_2 \geq 0$, $c = G_4^2/G_2^2 \geq 0$, and $k_2 = \infty$; if $G_2 = G_3 = 0$, then $Y(s) = G_1/s$, which is realizable as in Fig. 1(c) with $k_1 = G_1 \geq 0$, $k_2 = \infty$, and $k_3 = \infty$.

Case 4: $G_1 G_2 G_3 = 0$. Since G is non-negative definite, one obtains $G_4 G_5 G_6 = 0$, which can be referred to Cases 1–3.

Case 5: All the entries are non-zero and $G_1 G_6 - G_4 G_5 = 0$. One obtains

$$Y(s) = \left(\frac{s}{k_1} + \left(\frac{k_2}{s} + bs \right)^{-1} + \left(\frac{k_3}{s} + c \right)^{-1} \right)^{-1},$$

where $k_1 = G_1$, $k_2 = G_1(G_1 G_3 - G_5^2)/G_5^2$, $k_3 = G_1(G_1 G_2 - G_4^2)/G_4^2$, $b = G_4^2/G_6^2$, and $c = G_1^2/G_4^2$. Then, $Y(s)$ is realizable by the network as in Fig. 1(d) with $k_1, k_2, k_3, b, c \geq 0$.

Case 6: All the entries are non-zero and $G_2 G_5 - G_4 G_6 = 0$. One obtains

$$Y(s) = \left(\frac{s}{k_1} + \left(\frac{k_2}{s} + \left(\frac{1}{c} + \left(\frac{k_3}{s} + bs \right)^{-1} \right)^{-1} \right)^{-1} \right)^{-1},$$

where $k_1 = G_1$, $k_2 = G_1(G_1 G_2 - G_4^2)/G_4^2$, $k_3 = G_1^2(G_2 G_3 - G_6^2)/(G_3 G_4^2)$, $b = G_1^2/G_5^2$, and $c = G_1^2/G_4^2$. Then, $Y(s)$ is realizable by the network as in Fig. 1(e) with $k_1, k_2, k_3, b, c \geq 0$.

Case 7: All the entries are non-zero and $G_3 G_4 - G_5 G_6 = 0$. One obtains

$$Y(s) = \left(\frac{s}{k_1} + \left(\frac{k_2}{s} + \left(\frac{1}{bs} + \left(\frac{k_3}{s} + c \right)^{-1} \right)^{-1} \right)^{-1} \right)^{-1},$$

where $k_1 = G_1$, $k_2 = G_1(G_1 G_3 - G_5^2)/G_5^2$, $k_3 = G_1^2(G_2 G_3 - G_6^2)/(G_3 G_4^2)$, $b = G_1^2/G_5^2$, and $c = G_1^2/G_4^2$. Then, $Y(s)$ is realizable by the network as in Fig. 1(f) with $k_1, k_2, k_3, b, c \geq 0$.

Case 8: All the entries are non-zero and at least one principal minor is zero. From the discussion in the proof of Lemma 2, one knows that all the minors built in the same rows (columns) are zero, which can be referred to Cases 5–7.

In addition, one notes that all the realization processes of above cases belong to the method of the Foster Preamble. Hence, the proof is completed. ■

Theorem 4: Consider a positive-real function $Y(s)$ in the form of (4), where G as defined in (3) is a non-negative definite matrix with all the first-order minors and all the second-order minors being non-zero. If $Y(s)$ satisfies the conditions of Lemma 3, then it can be realized with one damper, one inerter and three springs, as one of the configurations shown in Fig. 2.

1. If Condition 1 holds, then $Y(s)$ is realizable as Fig. 2(a), with $k_1 = (G_1 G_2 - G_4^2)/(G_2 - G_4 G_6/G_5)$, $k_2 = G_6^2(G_1 - G_4 G_5/G_6)(G_1 G_2 - G_4^2)/(G_2 G_5 - G_4 G_6)^2$, $k_3 = G_4 G_6(G_4 G_5/G_6 - G_1)/(G_5(G_2 - G_4 G_6/G_5))$, $b = (G_1 G_2 - G_4^2)^2/(G_4 G_6 - G_2 G_5)^2$, and $c = (G_1 G_6 - G_4 G_5)^2/(G_4 G_6 - G_2 G_5)^2$.
2. If Condition 2 holds, then $Y(s)$ is realizable as Fig. 2(b), with $k_1 = G_1 G_6^2(G_1 - G_4 G_5/G_6)/(G_3 G_4^2)$, $k_2 = G_1 G_5 G_6/(G_3 G_4)$, $k_3 = G_1(G_3 - G_5 G_6/G_4)/G_3$, $b = G_1^2 G_6^2/(G_3^2 G_4^2)$, and $c = G_1^2/G_4^2$.
3. If Condition 3 holds, then $Y(s)$ is realizable as Fig. 2(c), with $k_1 = G_1 G_6^2(G_1 - G_4 G_5/G_6)/(G_2 G_5^2)$, $k_2 = G_1 G_4 G_6/(G_2 G_5)$, $k_3 = G_1(G_2 - G_4 G_6/G_5)/G_2$, $b = G_1^2/G_5^2$, and $c = G_1^2 G_6^2/(G_2^2 G_5^2)$.
4. If Condition 4 holds, then $Y(s)$ is realizable as Fig. 2(d), with $k_1 = G_4^2(G_3 - G_5 G_6/G_4)/(G_2 G_3)$, $k_2 = (G_4 G_5 G_6)/(G_2 G_3)$, $k_3 = G_5^2(G_2 - G_4 G_6/G_5)/(G_2 G_3)$, $b = G_5^2/G_3^2$, and $c = G_4^2/G_2^2$.

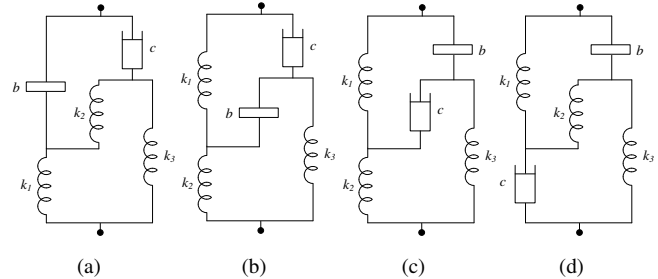

Fig. 2. The configurations covering all cases that satisfy the conditions of Lemma 3. In each case, $b, c, k_1, k_2, k_3 > 0$.

Proof: Condition 1: Since $G_4 G_5 G_6 < 0$, $\det(G) = 0$, and G with first-order minors and second-order minors being non-zero is non-negative definite, one implies that $k_1, k_2, k_3, b, c > 0$, and the admittance of the network in Fig. 1(a) is equivalent to (4).

Condition 2: Since $G_4 G_5 G_6 > 0$, $G_1 G_2 G_3 + G_4 G_5 G_6 - G_1 G_6^2 - G_3 G_4^2 = 0$, and G with first- and second-order minors non-zero is non-negative definite, one implies that $G_1 - G_4 G_5/G_6 > 0$, $G_2 - G_4 G_6/G_5 < 0$ and $G_3 - G_5 G_6/G_4 > 0$ by the discussions in the proof of Lemma 3. Hence, it is implied that $k_1, k_2, k_3, b, c > 0$, and the admittance of the network in Fig. 1(b) is equivalent to (4).

Condition 3: Since $G_4 G_5 G_6 > 0$, $G_1 G_2 G_3 + G_4 G_5 G_6 - G_1 G_6^2 - G_2 G_5^2 = 0$, and G with first- and second-order minors being non-zero is non-negative definite, one implies that $G_1 - G_4 G_5/G_6 > 0$, $G_2 - G_4 G_6/G_5 > 0$ and $G_3 - G_5 G_6/G_4 < 0$ by the discussions in the proof of Lemma 3. Hence, it is

implied that $k_1, k_2, k_3, b, c > 0$, and the admittance of the network in Fig. 1(c) is equivalent to (4).

Condition 4: Since $G_4G_5G_6 > 0$, $G_1G_2G_3 + G_4G_5G_6 - G_2G_5^2 - G_3G_4^2 = 0$, and G with first- and second-order minors non-zero is non-negative definite, one implies that $G_1 - G_4G_5/G_6 < 0$, $G_2 - G_4G_6/G_5 > 0$ and $G_3 - G_5G_6/G_4 > 0$ by the discussions in the proof of Lemma 3. Hence, it is implied that $k_1, k_2, k_3, b, c > 0$, and the admittance of the network in Fig. 1(d) is equal to (4). ■

E. Further Coefficient Transformation

To make the results concerned with admittance $Y(s)$ in the form of (4) become easier to check, this subsection converts the admittance into the form of (1), with realizability conditions in terms of $\alpha_3, \alpha_2, \alpha_1, \alpha_0, \beta_3, \beta_2, \beta_1$. Then, $\alpha_3 = G_1$, $\alpha_2 = G_1G_2 - G_4^2$, $\alpha_1 = G_1G_3 - G_5^2$, $\alpha_0 = \det(G)$, $\beta_3 = G_2$, $\beta_2 = G_3$, and $\beta_1 = G_2G_3 - G_6^2$. For simplicity, denote

$$W_1 := \alpha_3\beta_3 - \alpha_2, \quad W_2 := \alpha_3\beta_2 - \alpha_1, \quad W_3 := \beta_2\beta_3 - \beta_1,$$

$$W := \alpha_0 + 2\alpha_3\beta_2\beta_3 - \alpha_3\beta_1 - \alpha_2\beta_2 - \alpha_1\beta_3.$$

Then,

$$G_1 = \alpha_3, \quad G_2 = \beta_3, \quad G_3 = \beta_2, \quad G_4^2 = W_1, \quad G_5^2 = W_2,$$

$$G_6^2 = W_3, \quad G_4G_5G_6 = \frac{W}{2}, \quad G_1 - \frac{G_4G_5}{G_6} = \alpha_3 - \frac{W}{2W_3}, \quad (5)$$

$$G_2 - \frac{G_4G_6}{G_5} = \beta_3 - \frac{W}{2W_2}, \quad G_3 - \frac{G_5G_6}{G_4} = \beta_2 - \frac{W}{2W_1},$$

and $W^2 = 4W_1W_2W_3$.

Theorem 5: A positive-real function $Y(s)$ can be realized as the driving-point admittance of a one-port network, consisting of one damper, one inerter, and at most three springs, and satisfying Assumption 1, if and only if $Y(s)$ can be written in the form of (1), where the coefficients satisfy $\alpha_0, \alpha_1, \alpha_2, \alpha_3, \beta_1, \beta_2, \beta_3 \geq 0$, $W_1, W_2, W_3 \geq 0$, $W^2 = 4W_1W_2W_3$, and also satisfy either 1) at least one of $\alpha_1, \alpha_2, \alpha_3, \beta_1, \beta_2, \beta_3, W_1, W_2, W_3, (\beta_2 - W/(2W_1)), (\beta_3 - W/(2W_2)),$ and $(\alpha_3 - W/(2W_3))$ is zero; or 2) one of the following holds with Condition 1 not being satisfied: a) $W < 0$ and $\alpha_0 = 0$; b) $W > 0$ and $\alpha_0 + \alpha_3\beta_1 + \alpha_2\beta_2 - \alpha_1\beta_3 = 0$; c) $W > 0$ and $\alpha_0 + \alpha_3\beta_1 + \alpha_1\beta_3 - \alpha_2\beta_2 = 0$; d) $W > 0$ and $\alpha_0 + \alpha_1\beta_3 + \alpha_2\beta_2 - \alpha_3\beta_1 = 0$.

Proof: See [10] for a detailed proof. ■

Figs. 1 and 2(a)–2(d) are configurations achieving Conditions 1 and 2a–2d of Theorem 5, respectively, whose expressions of element values can be obtained from those in terms of G_1 to G_6 through (5).

III. FINAL REALIZABILITY RESULTS

To complete the present study, one considers the case when Assumption 1 does not hold.

Theorem 6: A positive-real function $Y(s)$ can be realized as the driving-point admittance of a one-port network, consisting of one damper, one inerter, and at most three springs, and not satisfying Assumption 1, if and only if $Y(s)$ can be written in the form of

$$Y(s) = \frac{\alpha_3s^3 + \alpha_2s^2 + \alpha_1s + \alpha_0}{\beta_3s^3 + \beta_2s^2 + \beta_1s},$$

where $\alpha_0, \alpha_1, \alpha_2, \alpha_3, \beta_1, \beta_2, \beta_3 \geq 0$, and one of the following five conditions holds: 1) $\alpha_3 = \beta_2 = \beta_3 = 0$, $\alpha_1, \alpha_2, \beta_1 > 0$; 2) $\alpha_3 = 0$, $\beta_2, \beta_3 > 0$, $\alpha_1\beta_1 - \alpha_0\beta_2 \geq 0$, $\alpha_1^2 + \alpha_0\beta_2^2 \geq \alpha_1\beta_1\beta_2$, $\alpha_0\beta_2 + \beta_2\beta_1^2 \geq \alpha_1\beta_1$, $\alpha_1\beta_3 = \alpha_2\beta_2$; 3) $\beta_2 = 0$, $\alpha_3, \beta_3 > 0$, $\alpha_2\beta_1 - \alpha_0\beta_3 \geq 0$, $\alpha_2^2 + \alpha_0\beta_3^2 \geq \alpha_2\beta_1\beta_3$, $\alpha_0\beta_3 + \beta_3\beta_1^2 \geq \alpha_2\beta_1$, $\alpha_1\beta_3 = \alpha_3\beta_1$; 4) $\beta_3 = 0$, $\alpha_3, \beta_2 > 0$, $\alpha_1\beta_1 - \alpha_0\beta_2 \geq 0$, $\alpha_1^2 + \alpha_0\beta_2^2 \geq \alpha_1\beta_1\beta_2$, $\alpha_0\beta_2 + \beta_2\beta_1^2 \geq \alpha_1\beta_1$, $\alpha_3\beta_1 = \alpha_2\beta_2$; 5) $\alpha_3, \beta_2, \beta_3 > 0$, $\alpha_1\beta_3 + \alpha_2\beta_2 \geq \alpha_3\beta_1$, $\alpha_2\beta_2 + \alpha_3\beta_1 \geq \alpha_1\beta_3$, $\alpha_1\beta_3 + \alpha_3\beta_1 \geq \alpha_2\beta_2$, $\alpha_3 = \beta_2\beta_3$, $\alpha_1^2\beta_3^2 + \alpha_2^2\beta_2^2 + \alpha_3^2\beta_1^2 + 4\alpha_0\alpha_3^2 = 2(\alpha_1\beta_3\alpha_2\beta_2 + \alpha_2\beta_2\alpha_3\beta_1 + \alpha_3\beta_1\alpha_1\beta_3)$.

Furthermore, networks in Fig. 3 with $b, c > 0$ and $k_1, k_2, k_3 \geq 0$ can realize each of the five conditions above, respectively.

Proof: See [10] for a detailed proof. ■

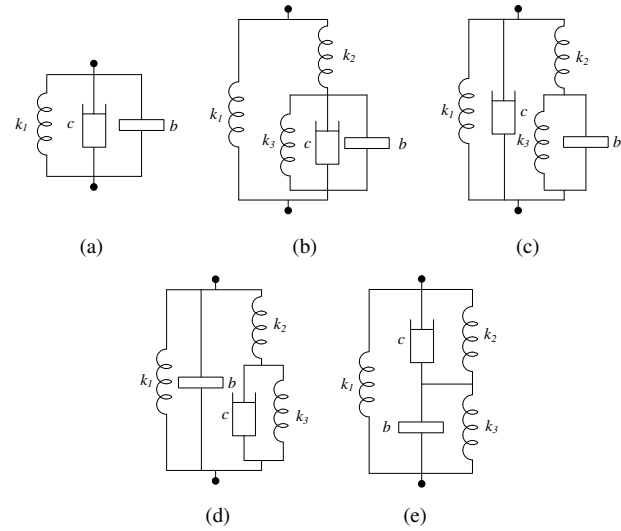

Fig. 3. The networks used to cover the conditions of Theorem 6. (a) for Condition 1; (b) for Condition 2; (c) for Condition 3; (d) for Condition 4; (e) for Condition 5. In each case, $b, c > 0$ and $k_1, k_2, k_3 \geq 0$.

Now, the final integrated conclusion is stated as follows.

Theorem 7: A positive-real function $Y(s)$ can be realized as the driving-point admittance of a one-port network Q consisting of one inerter, one damper, and at most three springs, if and only if $Y(s)$ can be written in the form of

$$Y(s) = \frac{\alpha_3s^3 + \alpha_2s^2 + \alpha_1s + \alpha_0}{\beta_4s^4 + \beta_3s^3 + \beta_2s^2 + \beta_1s}, \quad (6)$$

where $\alpha_0, \alpha_1, \alpha_2, \alpha_3, \beta_1, \beta_2, \beta_3 \geq 0$, which satisfy the conditions of Theorem 5 when $\beta_4 = 1$, or the conditions of Theorem 6 when $\beta_4 = 0$. Moreover, $Y(s)$ is realizable as one of configurations in Fig. 1, 2, or 3.

Proof: It is proved by combining Theorems 5 and 6. ■

Remark 1: A necessary and sufficient condition for the realizability of any positive-real function as the admittance of a one-port network with one inerter, one damper, and a finite number of springs in terms of (6) is given in [10], from which one can assert that the number of springs may not always be possible to reduce to three. Since there are five independent parameters in the networks of this note (corresponding to five elements), there must exist an equality constraint for the conditions in terms of G_1 to G_6 , which obviously cannot be equivalent to the conditions for networks without limiting

the number of springs (involving only inequality constraints). After converting the coefficients, the corresponding conditions in terms of (6) for the realizability of the two classes of networks are consequently not equivalent.

Remark 2: The direct enumeration method can be used as an alternative way to obtain the results of this note.

Remark 3: Through simulation, it can be shown that both the comfort performance and the dynamic tyre loads performance for a quarter-car system (see [3], [22]) are not substantially degraded by reducing the number of springs from four to three.

IV. NUMERICAL EXAMPLES

Example 1: Given a positive-real function $Y(s) = (45s^3 + 99s^2 + 54s + 22)/(9s^4 + 36s^3 + 27s^2 + 107)$, one can check that the conditions of Theorem 7 (Condition 2d of Theorem 5) holds. Therefore, $Y(s)$ is realizable as shown in Fig. 2(d) with $b = 1$, $c = 9/16$, $k_1 = 2$, $k_2 = 1/4$, and $k_3 = 11/4$.

Example 2: Given a positive-real function $Y(s) = (2s^2 + 4s + 1)/(s^3 + 4s^2 + s)$, one can check that the conditions of Theorem 7 (Condition 1 of Theorem 5) holds. Therefore, $Y(s)$ is realizable as shown in Fig. 1(e) with $b = 4$, $c = 1$, $k_1 = 2$, $k_2 = 2$, and $k_3 = 0$ (two springs).

Example 3: Given a positive-real function $Y(s) = (20s^3 + 44s^2 + 24s + 19)/(4s^4 + 16s^3 + 12s^2 + 47s)$, one can check that the conditions of Theorem 7 does not hold. Therefore, $Y(s)$ cannot be realized with one damper, one inerter, and at most three springs. However, it can be realized by the series connection of a spring k_4 with Fig. 2(d), where $b = 1$, $c = 9/16$, $k_1 = 15/8$, $k_2 = 3/8$, $k_3 = 21/8$, and $k_4 = 1/8$.

Example 4: For the suspension system [17, Fig. 3], $K_{ap}(s)$ is presented in [17, Eq. (27)], which can guarantee the same value of J_3 (see [17, Eq. (5)]) as the optimization function $K(s)$ of J_3 when $k_s = 50kN/m$ (intermediate static stiffness range) by the YALMIP method. As a result, the admittance of the suspension strut becomes $Y(s) = 50000/s + K_{ap}(s) = (28901000s^2 + 50550000s + 487620000)/(s^3 + 1011s^2 + 97524s)$. From [17, Fig. 12], it is known that $Y(s)$ is realizable with one damper, one inerter, and at most three springs. One can check that the conditions of Theorem 7 (Condition 1) holds, which further illustrates the validity and benefits of the results obtained in this note.

V. CONCLUSION

This note has studied the realization problem of one-port networks containing one inerter, one damper, and at most three springs. The first main contribution of this note is the derivation of a necessary and sufficient condition for a real symmetric matrix to be realizable as the admittance of a three-port resistive network containing at most three elements. Corresponding results for one-element-type mechanical networks then follow from the force-current analogy. The second main contribution is to obtain a necessary and sufficient condition for the realizability of any positive-real function as the admittance of a one-port mechanical network consisting of one damper, one inerter, and at most three springs (Theorem 7) as well as the network configurations to cover the condition

(Figs. 1–3). The element extraction approach was utilized, and the two cases when the admittance of the resulting three-port spring network is well-defined and when the admittance is non-well-defined were discussed, respectively. Numerical examples were provided for illustration. Further research endeavor will be directed to laboratory implementation of the new networks and their potential practical applications.

APPENDIX A

PREVIOUS LEMMAS OF THEOREM 2

Lemma 1: A positive-real function $Y(s)$ is realizable as the driving-point admittance of a one-port network, consisting of one damper, one inerter, and at most three springs, and satisfying Assumption 1, if and only if it can be written in the form of (4), where G as defined in (3) is non-negative definite, and there exists an invertible diagonal matrix $D = \text{diag}\{1, x, y\}$ with $x, y > 0$ such that DGD satisfies the conditions of Theorem 1.

Proof: Necessity. Let K be the admittance of the three-port resistive network obtained by extracting one damper and one inerter. Let $x = \sqrt{c}$, $y = \sqrt{b}$, and $D = \text{diag}\{1, x, y\}$, where $b, c > 0$. Then, $Y(s)$ can be in the form of (4), where $K = DGD$ as in (3) satisfies the conditions of Theorem 1.

Sufficiency. Since DGD satisfies the conditions of Theorem 1, $(1/s)DGD$ is realizable as a three-port network consisting of at most three springs. Consequently, $Y(s)$ is the admittance of the network in [6, Fig. 5], where $c = x^2$, $b = y^2$, and the admittance of X is $(1/s)DGD$. ■

Lemma 2: Consider a non-negative definite matrix G as defined in (3). If any first-order minor or second-order minor of G is zero, then there must exist an invertible diagonal matrix $D = \text{diag}\{1, x, y\}$ with $x, y > 0$ such that DGD satisfies the conditions of Theorem 1.

Proof: Case 1: At least one of the first-order minors is zero. It will be shown that there exists $D = \text{diag}\{1, x, y\}$ with $x, y > 0$ such that DGD satisfies Condition 1 of Theorem 1. If $G_4 = 0$ and other entries are nonzero, then Condition 1 of Theorem 1 is equivalent to $G_1 - y|G_5| \geq 0$, $x^2G_2 - xy|G_6| \geq 0$, and $y^2G_3 - y|G_5| - xy|G_6| \geq 0$ with $x, y > 0$ and at least two of the inequality signs being equality signs. If one chooses $x = G_1|G_6|/(G_2|G_5|)$ and $y = G_1/|G_5|$, then the first and second inequality signs become equality signs, and the third item always holds because of $G_1G_2G_3 - G_1G_6^2 - G_2G_5^2 = \det(G) \geq 0$ when $G_4 = 0$. Similarly, all the other subcases can be proved.

Case 2: At least one of the second-order minors is zero with all the first-order minors being nonzero. It can be shown that there exists $D = \text{diag}\{1, x, y\}$ with $x, y > 0$ such that DGD satisfies Condition 2 of Theorem 1. Indeed, if $G_1G_6 - G_4G_5 = 0$, then $G_1 = G_4G_5/G_6$, implying $G_4G_5G_6 > 0$ and $G_1/|G_4| = |G_5|/|G_6|$. Condition 2a of Theorem 1 becomes

$$\frac{|G_5|}{|G_6|} \leq x \leq \frac{G_1}{|G_4|}, \quad \frac{|G_6|}{G_3} \leq \frac{y}{x} \leq \frac{|G_4|}{|G_5|}, \quad (7)$$

$$(x|G_6| - |G_5|)(y/x) \leq xG_2 - |G_4| \quad (8)$$

with at least three inequality signs being equality signs. Letting $x = G_1/|G_4| = |G_5|/|G_6|$, the first and second inequality

signs of (7) are both equality signs, which implies that (8) holds because of $G_1G_2 - G_4^2 \geq 0$. Since $G_3 - G_5G_6/G_4 = G_3 - G_5^2/G_1 = (G_1G_3 - G_5^2)/G_1 \geq 0$, one can choose some $y > 0$ such that the second item of (7) holds with one equality sign. Similarly, the subcases of $G_4G_6 - G_2G_5 = 0$ and that of $G_3G_4 - G_5G_6 = 0$ can be proved. It has been shown in [2, pg. 46] that the following expressions hold: $(G_2G_3 - G_6^2)(G_1G_3 - G_5^2) - (G_3G_4 - G_5G_6)^2 = G_3\det G$, $(G_2G_3 - G_6^2)(G_1G_2 - G_4^2) - (G_4G_6 - G_2G_5)^2 = G_2\det G$, and $(G_1G_3 - G_5^2)(G_1G_2 - G_4^2) - (G_1G_6 - G_4G_5)^2 = G_1\det G$. Therefore, if a principal minor is zero, then the other two minors built from the same rows are both zero. ■

Lemma 3: Consider a non-negative definite matrix G in the form of (3) with all the first-order minors and all the second-order minors being non-zero. There exists an invertible diagonal matrix $D = \text{diag}\{1, x, y\}$ with $x, y > 0$ such that DGD satisfies the conditions of Theorem 1, if and only if one of the following conditions holds: 1) $G_4G_5G_6 < 0$ and $\det(G) = 0$; 2) $G_4G_5G_6 > 0$ and $G_1G_2G_3 + G_4G_5G_6 - G_1G_6^2 - G_3G_4^2 = 0$; 3) $G_4G_5G_6 > 0$ and $G_1G_2G_3 + G_4G_5G_6 - G_1G_6^2 - G_2G_5^2 = 0$; 4) $G_4G_5G_6 > 0$ and $G_1G_2G_3 + G_4G_5G_6 - G_2G_5^2 - G_3G_4^2 = 0$.

Proof: Necessity. Case 1: $G_4G_5G_6 < 0$. Condition 1 of Theorem 1 become $G_1 = x|G_4| + y|G_5|$, $x^2G_2 = x|G_4| + xy|G_6|$, and $y^2G_3 = y|G_5| + xy|G_6|$ with $x, y > 0$, from which one obtains

$$x = \frac{G_1|G_6| + |G_4||G_5|}{|G_4||G_6| + G_2|G_5|}, \quad y = \frac{G_1G_2 - G_4^2}{|G_4||G_6| + G_2|G_5|}, \quad (9)$$

and $\det(G) = 0$, which implies Condition 1 of this lemma.

Case 2: $G_4G_5G_6 > 0$. Condition 2a of Theorem 1 becomes (7) and (8) with each of the three having one and only one equality sign, implying $G_1 > G_4G_5/G_6$ and $G_3 > G_5G_6/G_4$. Since $G_2 \neq G_4G_6/G_5$, it is only possible that $|G_5|/|G_6| < |x| = G_1/|G_4|$ and $|G_6|/G_3 = |y|/|x| < |G_4|/|G_5|$. Thus, (8) with the equality sign gives $G_1G_2G_3 + G_4G_5G_6 - G_1G_6^2 - G_3G_4^2 = 0$, which implies Condition 2 of this lemma. Similarly, one can prove that Condition 2b of Theorem 1 implies Condition 3 of this lemma, and Condition 2c of Theorem 1 implies Condition 4 of this lemma.

Sufficiency. If Condition 1 of this lemma holds, let $x, y > 0$ satisfy (9). Then, it can be verified that Condition 1 of Theorem 1 holds following the proof of the necessity part.

In [6], it is shown that the non-negative definiteness of G and $G_4G_5G_6 > 0$ implies that at most one of $G_1 - G_4G_5/G_6$, $G_2 - G_4G_6/G_5$, $G_3 - G_5G_6/G_4$ is negative. If Condition 2 of this lemma holds, let $x = G_1/|G_4|$ and $y/x = |G_6|/G_3$. Then, one can obtain $\det(G) = G_5^2(G_4G_6/G_5 - G_2)$, implying $G_1 > G_4G_5/G_6$, $G_2 < G_4G_6/G_5$, and $G_3 > G_5G_6/G_4$. Thus, (7) holds with each of the two items having one equality sign. Since $G_1G_2G_3 + G_4G_5G_6 - G_1G_6^2 - G_3G_4^2 = 0$, (8) holds with equality sign. Hence, $D = \text{diag}\{1, x, y\}$ with $x, y > 0$ exists such that DGD satisfies Condition 2 of Theorem 1. Similarly, one can also prove that Condition 2 of Theorem 1 holds if Condition 3 or Condition 4 of this lemma holds. Since Condition 3 implies $G_1 > G_4G_5/G_6$, $G_2 > G_4G_6/G_5$, and $G_3 < G_5G_6/G_4$, and Condition 4 implies $G_1 < G_4G_5/G_6$, $G_2 > G_4G_6/G_5$, and $G_3 > G_5G_6/G_4$, the four conditions

given in the lemma have no overlap. ■

REFERENCES

- [1] R. Bott and R. J. Duffin, "Impedance synthesis without use of transformers," *Journal of Applied Physics*, vol. 20, no. 8, p. 816, 1949.
- [2] M. Z. Q. Chen, "Passive network synthesis of restricted complexity," Ph.D. dissertation, Eng. Dept., Cambridge Univ., Cambridge, U.K., Aug. 2007.
- [3] M. Z. Q. Chen, Y. Hu, and B. Du, "Suspension performance with one damper and one inerter," in *Proceedings of the 24th Chinese Control and Decision Conference (CCDC)*, Taiyuan, P. R. China, 2012, pp. 3534–3539.
- [4] M. Z. Q. Chen, C. Papageorgiou, F. Scheibe, F.-C. Wang, and M. C. Smith, "The missing mechanical circuit element," *IEEE Circuits Syst. Mag.*, vol. 9, no. 1, pp. 10–26, 2009.
- [5] M. Z. Q. Chen and M. C. Smith, "Electrical and mechanical passive network synthesis," in *Recent Advances in Learning and Control*, V. D. Blondel, S. P. Boyd, and H. Kimura (Eds.), New York: Springer-Verlag, 2008, LNCIS, vol. 371, pp. 35–50.
- [6] M. Z. Q. Chen and M. C. Smith, "Restricted complexity network realizations for passive mechanical control," *IEEE Trans. Automatic Control*, vol. 54, no. 10, pp. 2290–2301, 2009.
- [7] M. Z. Q. Chen and M. C. Smith, "A note on tests for positive-real functions," *IEEE Trans. Automatic Control*, vol. 54, no. 2, pp. 390–393, 2009.
- [8] M. Z. Q. Chen, K. Wang, Z. Shu, and C. Li, "Realizations of a special class of admittances with strictly lower complexity than canonical forms," *IEEE Trans. Circuits and Systems-I: Regular Papers*, vol. 60, no. 9, pp. 2465–2473, 2013.
- [9] M. Z. Q. Chen, K. Wang, Y. Zou, and J. Lam, "Realization of a special class of admittances with one damper and one inerter for mechanical control," *IEEE Trans. Automatic Control*, vol. 58, no. 7, pp. 1841–1846, 2013.
- [10] M. Z. Q. Chen, K. Wang, Y. Zou, and G. Chen, "Supplementary material to: Realization of three-port spring networks with inerter for effective mechanical control," Technical Report, Department of Mechanical Engineering, The University of Hong Kong, Hong Kong.
- [11] E. A. Guillemin, *Synthesis of Passive Networks*. New York: Wiley, 1957.
- [12] T. H. Hughes and M. C. Smith, "Algebraic criteria for circuit realizations," K. Hüper and J. Trumpf (Eds.), *Mathematical System Theory*, Charlotte: CreateSpace, 2012.
- [13] J. Z. Jiang and M. C. Smith, "Regular positive-real functions and five-element network synthesis for electrical and mechanical networks," *IEEE Trans. Automatic Control*, vol. 56, no. 6, pp. 1275–1290, 2011.
- [14] J. Z. Jiang and M. C. Smith, "Series-parallel six-element synthesis of biquadratic impedances," *IEEE Trans. Circuits and Systems-I: Regular Papers*, vol. 59, no. 11, pp. 2543–2554, 2012.
- [15] R. Kalman, "Old and new directions of research in system theory," in *Perspectives in Mathematical System Theory, Control, and Signal Processing*, J. C. Willems, S. Hara, Y. Ohta, and H. Fujioka (Eds.), New York: Springer-Verlag, 2010, LNCIS, vol. 398, pp. 3–13.
- [16] R. W. Newcomb, *Linear Multiport Synthesis*. New York: McGraw-Hill, 1966.
- [17] C. Papageorgiou and M. C. Smith, "Positive real synthesis using matrix inequalities for mechanical networks: Application to vehicle suspension," *IEEE Trans. Control Syst. Technol.*, vol. 14, no. 3, pp. 423–435, 2006.
- [18] M. C. Smith, "Synthesis of mechanical networks: the inerter," *IEEE Trans. Automatic Control*, vol. 47, no. 10, pp. 1648–1662, 2002.
- [19] P. Slepian and L. Weinberg, "Synthesis applications of paramount and dominant matrices," in *Proceedings of Nat. Elec. Conf.*, vol. 14, pp. 611–630, 1958.
- [20] K. Wang and M. Z. Q. Chen, "Generalized series-parallel RLC synthesis without minimization for biquadratic impedances," *IEEE Trans. Circuits and Systems II: Express Briefs*, vol. 59, no. 11, pp. 766–770, 2012.
- [21] F.-C. Wang, M.-F. Hong, and C.-W. Chen, "Performance analyses of building suspension control with inerters," in *Proceedings of the 46th IEEE Conference on Decision and Control*, New Orleans, USA, Dec. 2007, pp. 3786–3791.
- [22] F.-C. Wang and H.-A. Chan, "Vehicle suspensions with a mechatronic network strut," *Vehicle System Dynamics*, vol. 49, no. 5, pp. 811–830, 2011.
- [23] F.-C. Wang, M.-R. Hsieh, and H.-J. Chen, "Stability and performance analysis of a full-train system with inerters," *Vehicle System Dynamics*, vol. 50, no. 4, pp. 545–571, 2012.