



Title	Mechanical offset for torque ripple reduction for magnetless double-stator doubly-salient machine
Author(s)	Lee, CHT; Chau, KT; Liu, C; Ching, TW; Li, F
Citation	The 2014 IEEE International Magnetics (INTERMAG) Conference, Dresden, Germany, 4-8 May 2014. In IEEE Transactions on Magnetics, 2014, v. 50 n. 11, art no. 8103304
Issued Date	2014
URL	http://hdl.handle.net/10722/204062
Rights	IEEE Transactions on Magnetics. Copyright © Institute of Electrical and Electronics Engineers.

Mechanical Offset for Torque Ripple Reduction for Magnetless Double-Stator Doubly Salient Machine

Christopher H. T. Lee¹, K. T. Chau¹, *Fellow, IEEE*, Chunhua Liu¹, T. W. Ching², and Fuhua Li¹

¹Department of Electrical and Electronic Engineering, University of Hong Kong, Hong Kong

²Department of Electromechanical Engineering, University of Macau, Macau, China

This paper implements the new design structure, so-called the mechanical offset (MO) into the double-stator multitoothed switched reluctance (DS-MSR) machine to form the new MO-DS-MSR machine. The major distinction of the MO structure is to purposely mismatch the outer and inner rotor teeth with a conjugated angle. With the MO structure, the outer and the inner torque components can be compensated with each other, hence minimizing the resultant torque ripple. By employing the finite element analysis, the characteristics and performances of the proposed machines are analyzed and compared.

Index Terms—Double-stator (DS), doubly salient, magnetless, mechanical offset, multitoothed, torque ripple reduction.

I. INTRODUCTION

THERE is an accelerating pace on the development of electric vehicles (EVs) due to the increasing demands on the protection of the environment. Generally speaking, to increase the market penetration of EVs, the EV motor has to offer high efficiency, high-power density, high controllability, wide-speed range, and maintenance-free operation [1], [2]. In general cases, the permanent magnet (PM) machines can achieve all these goals and thus these types of machine have been actively developed [3], [4]. However, the prices of the PM materials have risen rapidly [5], [6]; and therefore the advanced magnetless machines, which contain the cost benefits, become more and more attractive.

Compared with the PM machines, the magnetless doubly salient machines suffer from relative poor torque density [7]. To resolve this deficiency, the multitoothed switched reluctance (MSR) machine has been proposed and developed [8], [9]. However, the MSR machine utilizes only half of its torque producing zone, and results with the larger torque ripple.

In this paper, by implementing a new design structure, so-called the mechanical offset (MO), into the double-stator (DS) MSR machine, the new MO-DS-MSR machine is proposed. With the proposed design, the outer and inner rotor teeth of the machine are purposely offset with a conjugated angle, such that both stators can contribute powers as the complementary torques with each other. These result with an offset function to produce a smoother resultant torque. By applying the finite element analysis [10], [11], the proposed design will be verified and compared.

II. PROPOSED MACHINES

Fig. 1(a) shows the topology of the conventional MSR machine, which consists of outer stator of 12 salient poles, each fitted with two teeth and results with the equivalent stator teeth of 24. This complies with the rotor of 20 poles. Fig. 1(b) shows the topology of the DS-MSR machine, which

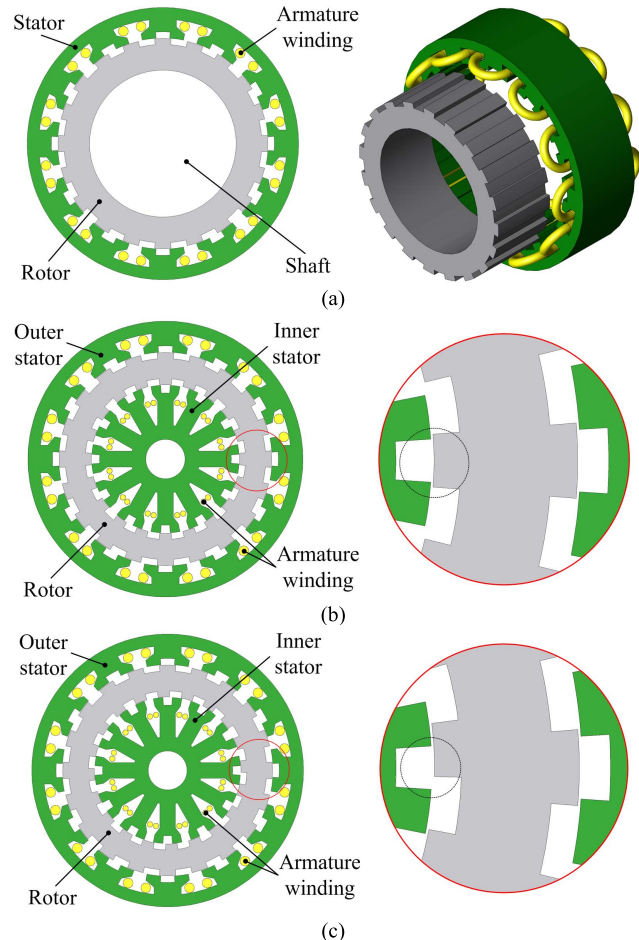

Fig. 1. Machine configurations. (a) MSR. (b) DS-MSR. (c) MO-DS-MSR.

obtains the similar structure as the MSR machine does. Meanwhile, the DS-MSR contains the sided-stator sandwiched-rotor structure. The outer and the inner rotor teeth of the DS-MSR are aligned with each other; hence, its outer and inner armature windings can be connected in series to ease the control algorithm.

Fig. 1(c) shows the topology of the proposed MO-DS-MSR machine, which has the similar topology as the DS-MSR machine does. Meanwhile, its outer and inner rotor teeth are purposely offset with a conjugated angle to each other,

Manuscript received March 6, 2014; revised April 16, 2014; accepted April 26, 2014. Date of current version November 18, 2014. Corresponding author: K. T. Chau (e-mail: ktchau@eee.hku.hk).

Color versions of one or more of the figures in this paper are available online at <http://ieeexplore.ieee.org>.

Digital Object Identifier 10.1109/TMAG.2014.2320964

0018-9464 © 2014 IEEE. Personal use is permitted, but republication/redistribution requires IEEE permission.

See http://www.ieee.org/publications_standards/publications/rights/index.html for more information.

TABLE I
KEY DATA OF PROPOSED MACHINES

Item	MSR	DS-MSR	MO-DS-MSR
Outer stator outside diameter	280.0 mm	280.0 mm	280.0 mm
Outer stator inside diameter	217.2 mm	217.2 mm	217.2 mm
Rotor outside diameter	216.0 mm	216.0 mm	216.0 mm
Rotor inside diameter	151.2 mm	151.2 mm	151.2 mm
Inner stator outside diameter	N/A	150.0 mm	150.0 mm
Inner stator inside diameter	N/A	40.0 mm	40.0 mm
Air-gap length	0.6 mm	0.6 mm	0.6 mm
Stack length	80.0 mm	80.0 mm	80.0 mm
No. of stator poles	12	12	12
No. of stator teeth	2	2	2
No. of equivalent stator poles	24	24	24
No. of rotor poles	20	20	20
No. of armature phases	3	3	3
Mechanical offset	0°	0°	60°
No of turns per outer coil	50	50	50
No of turns per inner coil	N/A	60	60

as indicated in the circle. Therefore, to drive the rotor properly, the outer and the inner windings should be controlled independently.

The design of the pole-pair arrangement for the machines is based on the following criteria [9]:

$$\begin{cases} N_{sp} = 2mj \\ N_{se} = N_{sp}N_{st} \\ N_r = N_{se} \pm 2j \end{cases} \quad (1)$$

where N_{sp} is the number of stator poles, N_{st} the stator teeth, N_{se} the equivalent stator poles, N_r the rotor poles, m the armature phases, and j is any integer. By selecting $m = 3$, $j = 2$ and $N_{st} = 2$, this ends up with $N_{se} = 24$, $N_r = 20$, and comes up the proposed machine structures. All machines are designed to avoid the magnetic saturation, and the key design data is shown in Table I.

The key features of the proposed machines are summarized as follows.

- 1) The cost of manufacturing is dominated by the material costs, while the PM material cost is far higher than its counterparts are [5], [6]. Without installation of any PM materials, the proposed machines enjoy the merit of high cost-effectiveness.
- 2) With the structure of multitoothed per stator pole, the proposed machine can offer the flux-modulation effect to boost up its torque density [8], [9].
- 3) By adopting the DS topology, the inner spacing of the machines can be utilized for further torque enhancement.
- 4) With the MO structure, the outer and inner torque components of the MO-DS-MSR can purposely offset with a conjugated angle to achieve torque ripple minimization.

III. MACHINE OPERATIONS

A. Conventional Conduction Algorithm

Similar as the conventional SR machines, to drive the MSR machines, a unipolar rectangular current, I_{rect} is fed to the armature winding during the increasing period of its self-inductance, L such that $\theta_c = \theta_2 - \theta_1$, as shown in Fig. 2(a). Under this conduction scheme, the corresponding reluctance torque can be described as [7], [9]

$$T = \frac{1}{2} I_{rect}^2 \frac{dL}{d\theta}. \quad (2)$$

It can be seen that the averaged rated torque is governed by the armature current value, which is also regulated by

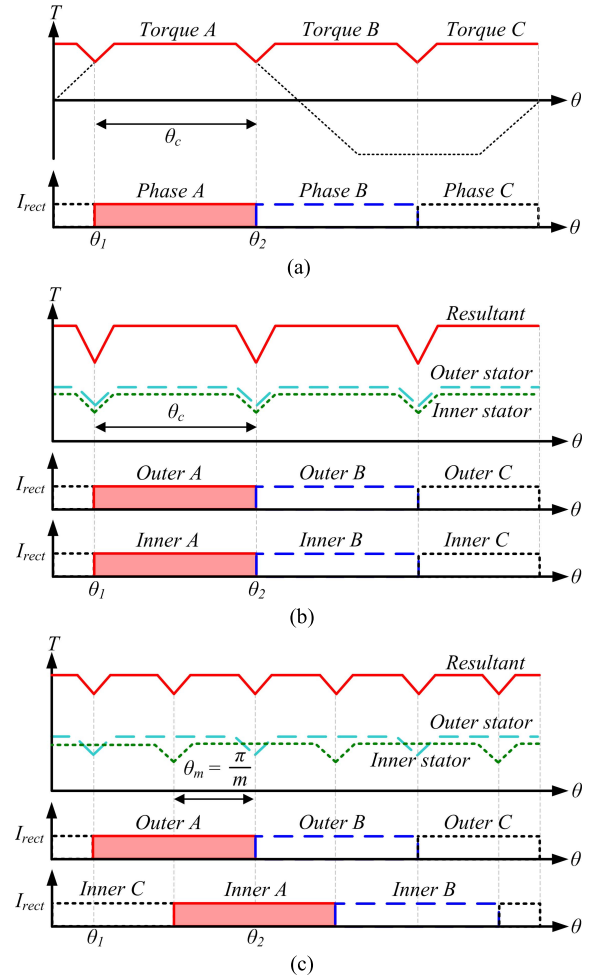

Fig. 2. Operating principles. (a) MSR. (b) DS-MSR. (c) MO-DS-MSR.

the machine design. Even though the torque ripple value is inversely proportional to the averaged rated torque, the increase of the armature current may also enlarge the torque ripple value and offset the effect of the increased rated torque. Hence, by purely regulating the armature current, it results insignificant improvement toward the torque ripple problem.

Conventionally, for the DS machine, its two stators are operated simultaneously with no phase shift, as shown in Fig. 2(b), and each armature phase can be described as

$$\begin{cases} i_k = I_{rect}, & \theta_1 \leq \theta \leq \theta_2 \\ i_k = 0, & 0 \leq \theta \leq \theta_1, \theta_2 \leq \theta \leq 2\pi \end{cases} \quad \text{for } k = 1, 2 \quad (3)$$

where i_1 is the outer armature current and i_2 the inner armature current. With this conduction scheme, the two stators can transfer the energy to the rotor simultaneously to boost up its torque density. However, the local maxima and local minima of the two torque components are constructively interfered with each other. Hence, with the conventional structure, the DS machine can enjoy only the torque enhancement advantage, but still has no significant improvement regarding to the torque ripple issue.

B. Proposed Mechanical Offset Algorithm

According to (2), the torque value is governed by the relative position among the stator and the rotor teeth. Hence, the local

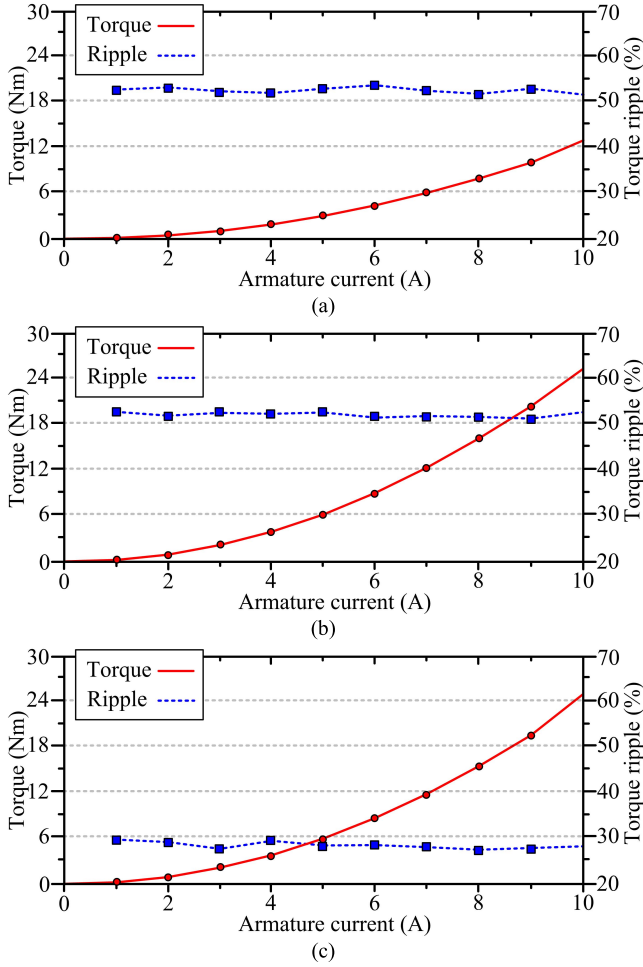

Fig. 3. Average torque and torque ripple performances. (a) MSR. (b) DS-MSR. (c) MO-DS-MSR.

maxima and the local minima are also governed by the relative stator-rotor position. With the proposed MO structure, the outer and the inner rotor teeth of the MO-DS-MSR machine are purposely mismatched with a conjugated electrical angle of $\theta_m = \pi/m$ as shown in Fig. 2(c). The two stators should be operated independently, in which one set of them adopts the conventional conduction algorithm as (3), and the other set adopts the following:

$$\begin{cases} i_{1 \text{ or } 2} = I_{\text{rect}}, & \theta_1 + \theta_m \leq \theta \leq \theta_2 + \theta_m \\ i_{1 \text{ or } 2} = 0, & \theta_m \leq \theta \leq \theta_1 + \theta_m, \quad \theta_2 + \theta_m \leq \theta \leq 2\pi + \theta_m. \end{cases} \quad (4)$$

With this special mismatched arrangement, the local maxima and the local minima are offset with each other. Hence, the torque ripples from the outer and the inner torque components can be compensated; hence producing the smoother resultant torque. To offer the better performance, the magnitudes of the two torque ripples should be adjusted as the similar level with the conjugated patterns. The torque ripple value and pattern can be regulated by the machine design, the armature current magnitude, the winding arrangement, and so on. However, the further study of the torque ripple characteristics is out of the scope of this paper.

Since the two torque components are complimented with each other, its averaged value should not be deteriorated.

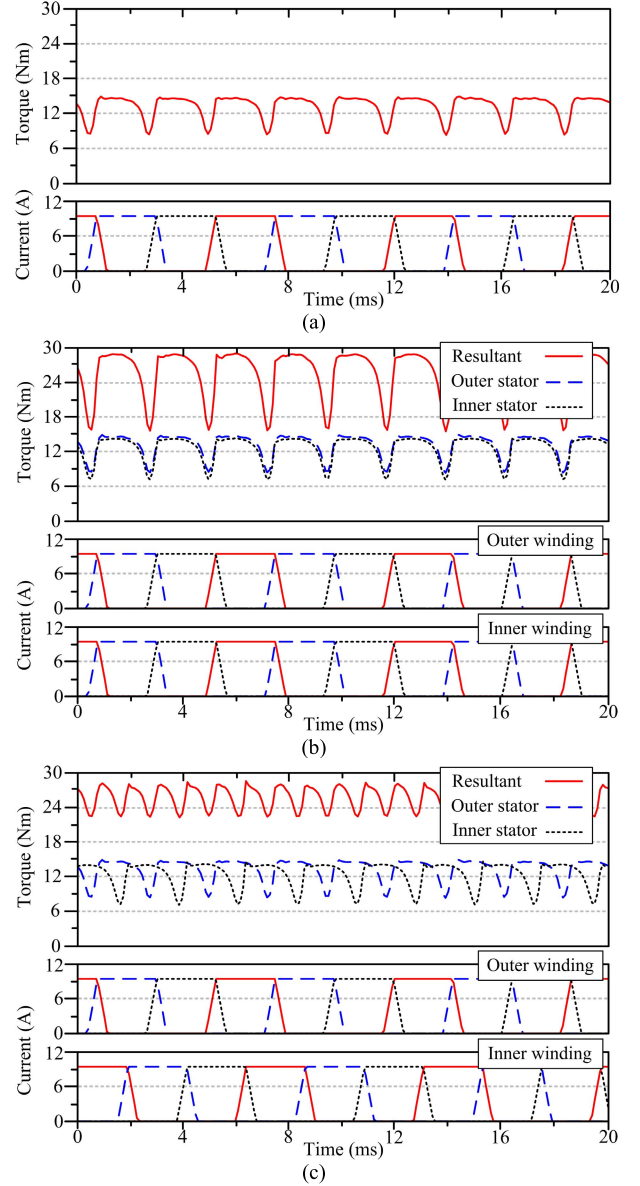

Fig. 4. Rated torque waveforms. (a) MSR. (b) DS-MSR. (c) MO-DS-MSR.

Therefore, with the proposed MO design, the DS machine can still offer the same torque level as those from the conventional one. Since the local maxima and the minima are distributed with the conjugated positions, the resultant torque under the MO design engages with higher ripple frequency. Meanwhile, the armature currents of the MO-DS-MSR are the same as the conventional one. Thus, its copper loss should be similar as its conventional counterpart.

IV. MACHINE PERFORMANCE ANALYSIS

By performing the finite element analysis, the performances of the proposed machines can be calculated and analyzed. First, the averaged torque and the torque ripple performances of the MSR, the DS-MSR, and the MO-DS-MSR machines are as shown in Fig. 3. It can be observed that the average torques of all three machines rising up with the increased armature currents, fulfilling the description of (2). As explained, compared with the MSR, the improved torque density of the DS-MSR has little influence toward the torque ripple values.

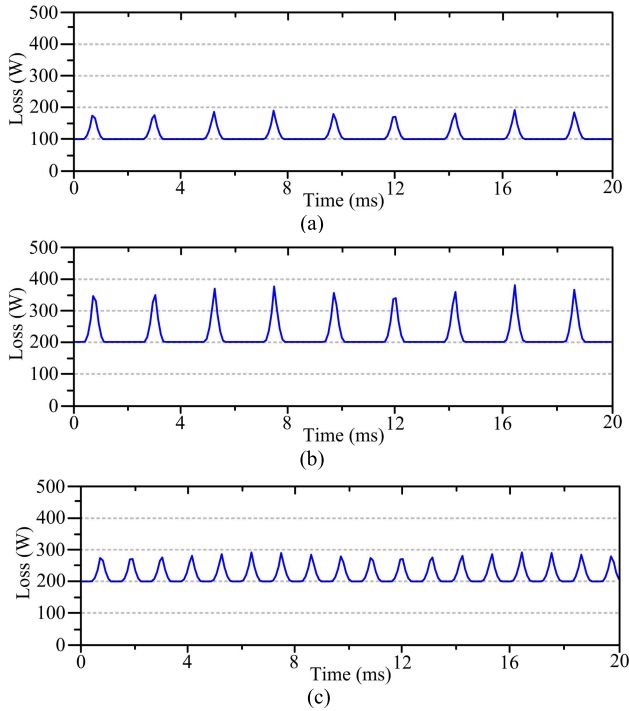

Fig. 5. Copper loss waveforms. (a) MSR. (b) DS-MSR. (c) MO-DS-MSR.

TABLE II
MACHINE PERFORMANCE COMPARISONS

Item	MSR	DS-MSR	MO-DS-MSR
Power	620 W	1220 W	1210 W
Rated speed	450 rpm	450 rpm	450 rpm
Outer stator torque	N/A	13.2 Nm	13.2 Nm
Inner stator torque	N/A	12.7 Nm	12.7 Nm
Resultant torque	13.2 Nm	25.9 Nm	25.7 Nm
Torque ripple	51.6 %	52.4 %	27.9 %
Copper loss	111 W	221 W	223 W

Meanwhile, by adopting the proposed MO structure, the MO-DS-MSR machine can greatly minimize its torque ripple level compared with its counterpart.

Second, the steady torque waveforms of the MSR, the DS-MSR, and the MO-DS-MSR machines are shown in Fig. 4. With the armature excitation of 10 A, it can be seen that the average steady torques of the MSR, the DS-MSR, and the MO-DS-MSR are 13.2, 25.9, and 25.7 N·m, respectively. The results confirm that the two torque components of the MO-DS-MSR can integrate perfectly and reach the same torque level as those with the conventional design.

Third, as shown in Fig. 4(b), based on the conventional design, the local maxima and the local minima of the outer and the inner torque ripples are additively integrated. This offsets the effect from the risen average torque and results with the torque ripple of 52.4%, as comparable with those from the MSR machine of 51.6%, as shown in Fig. 4(a). Hence, the DS-MSR machine gains no benefit according to the torque ripple issue. Meanwhile, as shown in Fig. 4(c), with the proposed MO design, the local maxima and the local minima are purposely mismatched and compensated with each other. Hence, the MO-DS-MSR machine can enjoy the whole benefit from the increased torque density and result with an improved torque ripple of 27.9%. In addition, it also shows that even with the same operating speed, the MO-DS-MSR machine results an increased torque ripple frequency.

Finally, the copper losses of the machines are shown in Fig. 5. The average copper losses of the MSR, the DS-MSR, and the MO-DS-MSR are 111, 221, and 223 W, respectively. These confirm the proposed MO structure has no negative effect toward the copper loss. In addition, all the copper losses are acceptable compared with its power levels.

V. CONCLUSION

In this paper, the new torque ripple minimized MO-DS-MSR machine is presented. The performances are analyzed by the TS-FEM and the comparison results are summarized in Table II, and concluded as follows.

- 1) Beneficial from the DS topology, the proposed machine can offer higher torque density than its counterpart.
- 2) With the conventional rotor teeth arrangement, the outer and the inner torque ripples are unfavorably integrated and offset the effect from the increased averaged torque.
- 3) The proposed MO structure can purposely mismatch and compensate the torque ripples; hence, allowing the DS machine to enjoy all the benefits.
- 4) The proposed doubly salient machines obtain no PM materials, thus having better cost-effectiveness than the PM machines do.
- 5) The machines are under prototyping and the experimental data will be the substance of our future papers.

ACKNOWLEDGMENT

This work was supported by the Hong Kong Research Grants Council, Hong Kong Special Administrative Region, Hong Kong, under Project 17200614.

REFERENCES

- [1] Z. Q. Zhu and D. Howe, "Electrical machines and drives for electric, hybrid, and fuel cell vehicles," *Proc. IEEE*, vol. 95, no. 4, pp. 746–765, Apr. 2007.
- [2] K. T. Chau, W. Li, and C. H. T. Lee, "Challenges and opportunities of electric machines for renewable energy," *Progr. Electromagn. Res. B*, vol. 42, pp. 45–74, Jun. 2012.
- [3] C. Liu, K. T. Chau, J. Z. Jiang, and S. Niu, "Comparison of stator-permanent-magnet brushless machines," *IEEE Trans. Magn.*, vol. 44, no. 11, pp. 4405–4408, Nov. 2008.
- [4] M. Cheng, W. Hua, J. Zhang, and W. Zhao, "Overview of stator-permanent magnet brushless machines," *IEEE Trans. Ind. Electron.*, vol. 58, no. 11, pp. 5087–5101, Nov. 2011.
- [5] M. Chen, K. T. Chau, W. Li, and C. Liu, "Cost-effectiveness comparison of coaxial magnetic gears with different magnet materials," *IEEE Trans. Magn.*, vol. 50, no. 2, pp. 821–824, Feb. 2014.
- [6] C. H. T. Lee, C. Liu, and K. T. Chau, "A magnetless axial-flux machine for range-extended electric vehicle," *Energies*, vol. 7, no. 3, pp. 1483–1499, Mar. 2014.
- [7] C. H. T. Lee, K. T. Chau, C. Liu, and Q. Chun, "Design and analysis of a new multitoothed magnetless doubly salient machine," *IEEE Trans. Appl. Supercond.*, vol. 24, no. 3, pp. 1–4, Jun. 2014.
- [8] J. Faiz, J. W. Finch, and H. M. B. Metwally, "A novel switched reluctance motor with multiple teeth per stator pole and comparison of such motors," *Electr. Power Syst. Res.*, vol. 34, no. 3, pp. 197–203, Sep. 1995.
- [9] C. H. T. Lee, K. T. Chau, C. Liu, D. Wu, and S. Gao, "Quantitative comparison and analysis of magnetless machine with reluctance topologies," *IEEE Trans. Magn.*, vol. 49, no. 7, pp. 3969–3972, Jul. 2013.
- [10] S. J. Salon, *Finite Element Analysis of Electrical Machines*. Boston, MA, USA: Kluwer, 1995.
- [11] J. Chen, C. V. Nayar, and L. Xu, "Design and finite-element analysis of an outer-rotor permanent-magnet generator for directly coupled wind turbines," *IEEE Trans. Magn.*, vol. 36, no. 5, pp. 3802–3809, Sep. 2000.