



Title	Generalized series-parallel RLC synthesis without minimization for biquadratic impedances
Author(s)	Wang, K; Chen, MZ
Citation	IEEE Transactions on Circuits and Systems II-Express Briefs, 2012, v. 59 n. 11, p. 766-770
Issued Date	2012
URL	http://hdl.handle.net/10722/189180
Rights	IEEE Transactions on Circuits and Systems Part 2: Express Briefs. Copyright © IEEE

Generalized Series–Parallel RLC Synthesis Without Minimization for Biquadratic Impedances

Kai Wang and Michael Z. Q. Chen, *Member, IEEE*

Abstract—This brief is concerned with the realization problem of biquadratic impedances, motivated by the recent development in passive mechanical control. This brief generalizes a realization procedure of a special class of biquadratic impedances to a more general form, and the resulting series–parallel RLC networks whose elements are no more than those in Bott–Duffin’s networks are obtained without minimization. The realizability condition is proven by providing a constructive synthesis procedure. The series–parallel network obtained contains elements no more than those of Bott–Duffin’s network when the impedance is nonregular.

Index Terms—Electric circuits, inerter, mechanical networks, network synthesis, passivity.

I. INTRODUCTION

PASSIVE NETWORK synthesis is a classical subject in electrical circuit theory that experienced a “golden era” from the 1930s to the 1970s [1]–[3], [13], but certain aspects are still considered incomplete, such as the question of minimality of realization in terms of the total number of elements. However, interest in passive network synthesis has declined despite relatively recent developments in positive-real functions [9], [12], [20] and the stability of behavioral systems [22]. Recently, a new passive mechanical element, named *inertor*¹ [23], has been introduced with the property that the (equal and opposite) force applied at the terminals is proportional to the relative acceleration between them. Partially due to the inerter and its applications (see [5] and references therein), interest in passive network synthesis has been revived [4], [6]–[8], [14], [16], [17]. There has been an independent call for a renewed attempt by Kalman [18].

This brief is concerned with the realization problem of biquadratic impedances in series–parallel connections using resistors, inductors, and capacitors (RLC). The biquadratic impedance is one of the most important topics in network synthesis [10], [11], [17], [19], [25] and can provide guidance to the development of the more general cases. Notwithstanding its simple form, many problems are not yet solved, such

as minimal realizations. Using the Bott–Duffin method [3], [13], any positive-real biquadratic impedance is realizable by a series–parallel RLC network containing no more than nine elements. Although enumeration [19], [25] has been successfully used to investigate the realization with at most five and six elements, it is much more complex and difficult to apply this method to networks containing more than six elements, and the results would have limited guidance to impedances of higher degrees. Hence, investigation into some more general realization procedures is needed, such as the development of realization procedure in [24]. In [24], an alternative realization procedure for biquadratic impedances is proposed and the resulting network does not contain more elements than Bott–Duffin’s result. However, the biquadratic impedances investigated in [24] are assumed to contain *multiple* real zeros (poles) and arbitrary poles (zeros). Hence, a generalization of this procedure to a more general class of biquadratic impedances is required.

Section II presents the main results. Section II-A investigates the realization problem of the class of biquadratic impedances with real zeros (poles) and arbitrary poles (zeros). Section II-B further generalizes the class to arbitrary biquadratic impedances. Conclusions are drawn in Section III.

II. MAIN RESULTS

A. Biquadratic Impedances With Real Zeros and Arbitrary Poles

We focus our attention on a biquadratic impedance

$$Z(s) = \frac{As^2 + Bs + C}{Ds^2 + Es + F} \quad (1)$$

where $A, B, C, D, E, F \geq 0$. We first present a few lemmas before establishing our main results.

Lemma 1: [8] Consider a biquadratic impedance $Z(s)$ in the form of (1) where $A, B, C, D, E, F \geq 0$. Then, $Z(s)$ is positive-real if and only if $(\sqrt{AF} - \sqrt{CD})^2 \leq BE$.

Lemma 2: [15] Consider a positive-real biquadratic impedance $Z(s)$ in the form of (1), where $A, B, C, D, E, F \geq 0$. If any of the coefficients is zero, then $Z(s)$ can be realized with at most four elements.

Although the next lemma can be easily extended from a result in [15], we provide an alternative proof as follows in order to facilitate our investigation.

Lemma 3: Consider a biquadratic impedance $Z(s)$ in the form of (1) where $A, C, D, F > 0$ and $B, E \geq 0$. If $AF = CD$, then $Z(s)$ can be realized by a series–parallel network containing at most four elements. If, in addition, either B or E is zero, then the number of elements is at most three; if, in addition, $AE = BD$, then $Z(s)$ is realizable as a resistor.

Manuscript received May 21, 2012; revised July 31, 2012; accepted October 18, 2012. Date of publication December 20, 2012; date of current version January 4, 2013. This work was supported in part by Hong Kong University Committee on Research and Conference Grants under Grant 201008159001, by National Natural Science Foundation of China under Grant 61004093, by “973 Program” under Grant 2012CB720200, and by “Innovative research projects for the graduate students of the universities in Jiangsu province” CXLX12_0200. This brief was recommended by Associate Editor R. Martins.

K. Wang is with the School of Automation, Nanjing University of Science and Technology, Nanjing 210094, China.

M. Z. Q. Chen is with the Department of Mechanical Engineering, The University of Hong Kong, Hong Kong (e-mail: mzcqchen@gmail.com).

Digital Object Identifier 10.1109/TCSII.2012.2228395

¹The Chinese translation “Guanrong” [26] was coined by M. Z. Q. Chen and Professor Yun Zou at Nanjing University of Science and Technology.

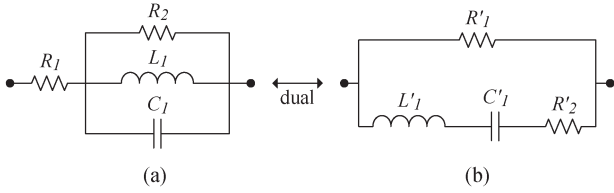

Fig. 1. Networks discussed in Lemma 3.

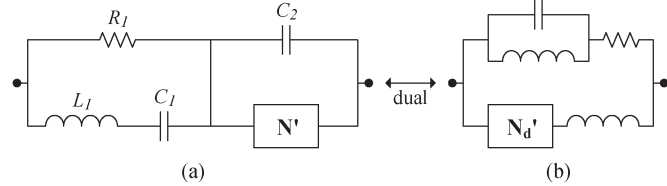

Fig. 2. Networks discussed in Lemma 5.

Proof: $Z(s)$ can be decomposed as $Z(s) = A/D + (BD - AE)s / (D^2s^2 + DEs + DF)$ when $AE < BD$ and $AF = CD$ and $Z(s) = (D/A + (AE - BD)s / (A^2s^2 + ABs + AC))^{-1}$ when $AE \geq BD$ and $AF = CD$. Then, it can be easily proven. ■

From Lemma 2 and Lemma 3, we can assume that $A, B, C, D, E, F > 0$ and $AF \neq CD$ to investigate other realizations.

Lemma 4: [2, Corollary 3.1] Consider a strictly Hurwitz polynomial $Q(s)$. Let $Q(s) = m(s) + n(s)$, where $m(s)$ and $n(s)$ are even and odd parts of $Q(s)$, respectively. Then, $Z(s) = m(s)/n(s)$ must be a reactance function.

The next lemma has been stated without a detailed proof in [11] and [24]. We restate it here with a brief proof.

Lemma 5: [11], [24] Consider a biquadratic impedance $Z(s)$ in the form of (1) where $A, B, C, D, E, F > 0$ and $AF \neq CD$. If $|AF - CD| \leq BE$, then $Z(s)$ can be realized by a series-parallel network with at most seven elements.

Proof: Suppose that $AF < CD$, then decompose $Z(s)$ as $Z(s) = (A/D) \cdot m_2 / (m_2 + n_2) + (A/D) \cdot (m_1 + n_1 - m_2) / (m_2 + n_2) := Z_1(s) + Z_2(s)$, where $m_1 = s^2 + C/A$, $n_1 = Bs/A$, $m_2 = s^2 + F/D$, and $n_2 = Es/D$. Then, $Z(s)$ is realizable as shown in Fig. 2(a) based on Lemma 4 and by removing the pole of $Z_2(s)^{-1}$ at $s = \infty$. When $AF > CD$, by duality, we obtain a network as in Fig. 2(b), where N'_d is the dual network of N' . ■

It has been shown in [24] that, for any impedance of this class not satisfying the condition of Lemma 5, a positive q can always be found such that $Z(s) = H(s + z)^2 / (s^2 + b_1s + b_0)$ or $Z(s) = H(s^2 + a_1s + a_0) / (s + p)^2$ can be realized as series-parallel networks with at most nine elements by simultaneous multiplication of $(s + q)$ when the condition of Lemma 5 does not hold. In this subsection, we generalize this class to the biquadratic impedances with real zeros (poles) and arbitrary poles (zeros). By duality, it suffices to focus on

$$Z(s) = H \frac{(s + z_1)(s + z_2)}{s^2 + b_1s + b_0} \quad (2)$$

where $H, b_0, b_1 > 0$, $z_2 \geq z_1 > 0$ and $z_1z_2 \neq b_0$. Moreover, by the frequency transformation $s \leftrightarrow s^{-1}$, it can be assumed that $z_1z_2 > b_0$. Since $Z(s)$ should be positive-real and we

assume that it does not satisfy the condition of Lemma 5, the coefficients should further satisfy

$$\frac{(\sqrt{z_1z_2} - \sqrt{b_0})^2}{z_1 + z_2} \leq b_1 < \frac{z_1z_2 - b_0}{z_1 + z_2}. \quad (3)$$

Obviously, $Z(s)$ is a minimum function if and only if $b_1 = (\sqrt{z_1z_2} - \sqrt{b_0})^2 / (z_1 + z_2)$.

The following theorem presents a constructive procedure, different from the Bott-Duffin synthesis, to synthesize a biquadratic impedance $Z(s)$ in the form of (2).

Theorem 1: Consider a biquadratic impedance $Z(s)$ in the form of (2), where $H, b_0, b_1 > 0$, $z_2 \geq z_1 > 0$, $z_1z_2 > b_0$ and (3) are satisfied. Then, through a constructive procedure, $Z(s)$ can be realized by a series-parallel network containing at most nine elements. In particular, if $Z(s)$ is a minimum function, then the number of elements is at most eight.

Proof: This theorem is proven by presenting the synthesis procedure. First, multiplying the numerator and denominator with a common factor $(s + q)$ with $q > 0$, $Z(s)$ is obtained as

$$Z(s) = H \frac{s^2 + (z_1 + z_2)s + z_1z_2}{s^2 + b_1s + b_0} \cdot \frac{s + q}{s + q} =: H \frac{m_1 + n_1}{m_2 + n_2}$$

where $m_1 = (q + z_1 + z_2)s^2 + z_1z_2q$, $n_1 = s^3 + ((z_1 + z_2)q + z_1z_2)s$, $m_2 = (q + b_1)s^2 + b_0q$, and $n_2 = s^3 + (b_1q + b_0)s$. Then, decompose $Z(s)$ as $Z(s) = Z_1(s) + Z_2(s)$, where $Z_1(s) = Hn_2 / (m_2 + n_2) = H(s^3 + (b_1q + b_0)s) / (s^3 + (q + b_1)s^2 + (b_1q + b_0)s + b_0q)$ and $Z_2(s) = H(m_1 + n_1 - n_2) / (m_2 + n_2) = H((q + z_1 + z_2)s^2 + ((z_1 + z_2 - b_1)q + z_1z_2 - b_0)s + z_1z_2q) / (s^3 + (q + b_1)s^2 + (b_1q + b_0)s + b_0q)$. Since $m_2 + n_2$ is a strictly Hurwitz polynomial, we know n_2/m_2 must be a reactance by Lemma 4. Furthermore, so is $n_2 / (Hm_2)$, and it can be realized by a lossless network containing two inductors and one capacitor. Therefore, $Z_1(s) = 1 / (1/H + m_2 / (Hn_2))$ is realizable as the network with one resistor in parallel with a lossless subnetwork containing three reactive elements. For $Z_2(s)$, removal of the pole of $Z_2^{-1}(s)$ at infinity yields $Z_2^{-1}(s) = s / (H(q + z_1 + z_2)) + Z_3^{-1}(s)$, where $Z_3(s)$ is a biquadratic function in the form of

$$Z_3(s) = \frac{\alpha_2s^2 + \alpha_1s + \alpha_0}{\beta_2s^2 + \beta_1s + \beta_0} \quad (4)$$

with $\alpha_2 = H(q + z_1 + z_2)^2$, $\alpha_1 = H((z_1 + z_2 - b_1)q + (z_1z_2 - b_0)(q + z_1 + z_2))$, $\alpha_0 = H z_1z_2q(q + z_1 + z_2)$, $\beta_2 = q^2 + 2b_1q + (b_1z_1 + b_1z_2 + b_0 - z_1z_2)$, $\beta_1 = b_1q^2 + (b_1z_1 + b_1z_2 + b_0 - z_1z_2)q + b_0(z_1 + z_2)$, and $\beta_0 = b_0q(q + z_1 + z_2)$. Letting $\alpha_2\beta_0 = \alpha_0\beta_2$ yields the following quadratic equation in q :

$$(z_1z_2 - b_0)q^2 + 2(z_1z_2b_1 - b_0z_1 - b_0z_2)q + (z_1z_2(z_1 + z_2)b_1 - (z_1^2z_2^2 + b_0z_1^2 + b_0z_2^2 + b_0z_1z_2)) = 0. \quad (5)$$

To investigate the property of its roots, denote

$$\gamma(b_1) := z_1z_2(z_1 + z_2)b_1 - (z_1^2z_2^2 + b_0z_1^2 + b_0z_2^2 + b_0z_1z_2).$$

$\gamma(b_1)$ can be regarded as a polynomial function of b_1 . Furthermore, denote the lower and upper bounds of b_1 in (3) as $x_1 = (\sqrt{z_1z_2} - \sqrt{b_0})^2 / (z_1 + z_2)$ and $x_2 = (z_1z_2 - b_0) / (z_1 + z_2)$. After calculation, we obtain $\gamma(b_1)|_{b_1=x_1} = -(b_0z_1^2 + b_0z_2^2 + 2z_1z_2\sqrt{z_1z_2}\sqrt{b_0}) < 0$ and $\gamma(b_1)|_{b_1=x_2} = -b_0(z_1 + z_2)^2 < 0$. Since $x_1 \leq b_1 < x_2$, through Sturm's theorem [13], $\gamma(b_1)$ has no pole in $[x_1, x_2)$. Consequently, it is implied that $\gamma(b_1) < 0$,

suggesting that (5) has one and only one positive root q_0 together with the assumption that $z_1 z_2 > b_0$.

It is not difficult to see that $\alpha_2, \alpha_0, \beta_0 > 0$ when $q = q_0$. In addition, we have the following relations: $b_1 < (z_1 z_2 - b_0)/(z_1 + z_2) \Leftrightarrow z_1 + z_2 - b_1 > (b_1 z_1 + b_0 + z_2^2)/z_2 \Rightarrow z_1 + z_2 - b_1 > 0$. Hence, we can see $\alpha_1 > 0$ when $q = q_0$. It is seen that $\beta_2 = 0$ in q has one and only one positive root $q = q_1$ as $b_1 z_1 + b_1 z_2 + b_0 - z_1 z_2 < 0$. To show that $\beta_2 > 0$, it suffices to show that $q_1 < q_0$. Substituting $q_1^2 + 2b_1 q_1 + (b_1 z_1 + b_1 z_2 + b_0 - z_1 z_2) = 0$ into the left-hand side of (5), i.e., $W(q_1) := (z_1 z_2 - b_0)q_1^2 + 2(z_1 z_2 b_1 - b_0 z_1 - b_0 z_2)q_1 + (z_1 z_2(z_1 + z_2)b_1 - (z_1^2 z_2^2 + b_0 z_1^2 + b_0 z_2^2 + b_0 z_1 z_2))$, we can obtain that $W(q_1) = 2b_0(b_1 - z_1 - z_2)q_1 + b_0(b_1 z_1 + b_1 z_2 + b_0 - z_1 z_2 - (z_1 + z_2)^2) < 0$, which shows that $q_1 < q_0$.

Now, it remains to show that $\beta_1 \geq 0$ when $q = q_0$. If we regard β_1 as a quadratic function of q with $q > 0$, then the discriminant of β_1 can be calculated as $\delta(b_1) = (b_1 z_1 + b_1 z_2 + b_0 - z_1 z_2)^2 - 4b_1 b_0(z_1 + z_2) = (z_1 + z_2)^2 b_1^2 - 2(z_1 z_2(z_1 + z_2) + b_0(z_1 + z_2))b_1 + (z_1 z_2 - b_0)^2$. Hence, the two roots of $\delta(b_1) = 0$ are solved as $b_1^{(1)} = (\sqrt{z_1 z_2} - \sqrt{b_0})^2/(z_1 + z_2)$ and $b_1^{(2)} = (\sqrt{z_1 z_2} + \sqrt{b_0})^2/(z_1 + z_2)$. It is observed that $b_1^{(1)} = x_1$ and $b_1^{(2)} - x_2 = (2\sqrt{b_0}(\sqrt{z_1 z_2} + \sqrt{b_0}))/ (z_1 + z_2) > 0$. Hence, we can see $\delta(b_1) < 0$ when $x_1 < b_1 < x_2$ and $\delta(b_1) = 0$ when $b_1 = x_1$. When $x_1 < b_1 < x_2$, it follows that $\beta_1 > 0$ when $q = q_0$. Thus, by Lemma 3, $Z_3(s)$ is realizable by the network in Fig. 1 (some elements may be short or open circuited), which contains at most four elements. When $b_1 = x_1$, i.e., $Z(s)$ is a minimum function, it is seen that the quadratic equation $\beta_1 = 0$ in q has a common positive root, which is $q^{(0)} = (z_1 z_2 - (z_1 + z_2)b_1 - b_0)/(2b_1) = (\sqrt{b_0}(z_1 + z_2))/(\sqrt{z_1 z_2} - \sqrt{b_0})$. It is noted that (5) is satisfied when $q = q^{(0)}$ and $b_1 = x_1$. This means that $q_0 = q^{(0)}$ when $b_1 = x_1$. Hence, $\beta_1 = 0$ when $q = q^{(0)}$ and $b_1 = x_1$. By Lemma 3, $Z_3(s)$ is realizable with at most three elements. Then, the proof is completed. ■

The realization procedure in Theorem 1 is summarized as follows.

- 1) Calculate the positive root q_0 from (5) in q , which is proven to contain one and only one positive root. This guarantees the solution of this procedure to be unique.
- 2) Multiply the numerator and denominator of $Z(s)$ with the factor $(s + q_0)$ simultaneously and express it as $Z(s) = H(m_1 + n_1)/(m_2 + n_2)$. This operation makes the realization possible at the cost of the complexity of the configurations since the degrees of numerator and denominator both increase by one.
- 3) Decompose $Z(s)$ as $Z(s) = Z_1(s) + Z_2(s)$, where $Z_1(s) = Hn_2/(m_2 + n_2)$ and $Z_2(s) = H(m_1 + n_1 - n_2)/(m_2 + n_2)$. Then, it is seen that the final realization must contain two subnetworks in a series, whose impedances are $Z_1(s)$ and $Z_2(s)$, respectively.
- 4) Since we can express $Z_1(s)$ in the form of $Z_1(s) = (1/H + m_2/(Hn_2))^{-1}$, it can obviously be realized as a resistor in parallel with a lossless subnetwork whose admittance is $m_2/(Hn_2)$. In addition, $m_2/(Hn_2)$ is realizable with two inductors and one capacitor in Foster's second form [2, p. 49].
- 5) Removing the pole of $Z_2(s)$ at $s = \infty$, it follows that $Z_2(s)$ is realizable as a capacitor in parallel with a subnetwork N whose impedance is $Z_3(s)$. The proof in Theorem 1 guarantees that $Z_3(s)$ can always be realized as in Fig. 1 and the method in the proof of Lemma 3 is used.

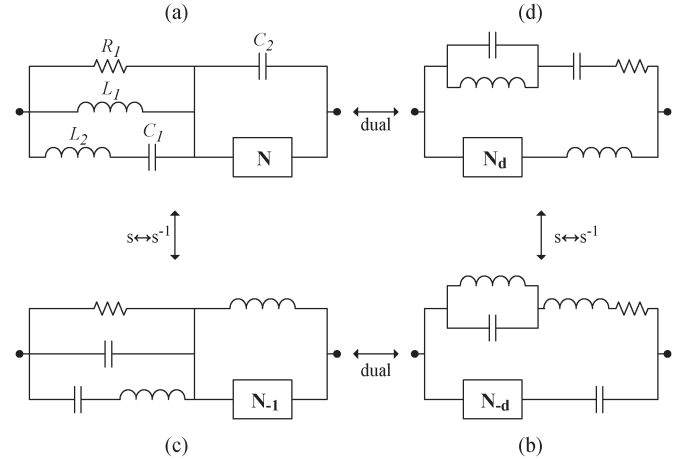

Fig. 3. Networks obtained by the alternative realization method.

The final network is a series connection of the realizations of $Z_1(s)$ and $Z_2(s)$, which is a series-parallel network as shown in Fig. 3(a). The realization is unique because of the unique solution of (5) in q . Since any regular biquadratic impedance $Z(s)$ is realizable with at most five elements [15] by the Foster preamble, it is only necessary to assume that $Z(s)$ is nonregular for the statement of the next theorem.

Theorem 2: Consider a nonregular positive-real biquadratic impedance $Z(s)$ in the form of (1) with $A, B, C, D, E, F > 0$. If $B^2 - 4AC \geq 0$ or $E^2 - 4DF \geq 0$, then $Z(s)$ can be realized by the network shown in Fig. 2 through the method in the proof of Lemma 5 or by the network shown in Fig. 3 using the procedure outlined in Theorem 1 (or its dual or $s \leftrightarrow s^{-1}$). Furthermore, if the networks are to be realized in series-parallel connections, then it contains elements no more than those of Bott-Duffin's network.

Proof: Since $Z(s)$ is nonregular, it is known from [15, Lemma 6] that $AF \neq CD$. Based on Lemma 5, we know that $Z(s)$ can be realized by the network shown in Fig. 2 through the method in the proof of Lemma 5 if $|AF - CD| \leq BE$.

Therefore, we assume that the condition of Lemma 5 does not hold. If $B^2 - 4AC \geq 0$ and $AF < CD$, then $Z(s)$ can be written in the form of (2), where $H, b_0, b_1 > 0, z_2 \geq z_1 > 0, z_1 z_2 > b_0$, and (3) are satisfied. Through the method in Theorem 1 (outlined right after its proof), the series-parallel network shown in Fig. 3(a) containing at most nine elements is derived. In particular, the number of elements is at most eight when $Z(s)$ is a minimum function. Since the Bott-Duffin method can realize a nonregular positive-real biquadratic impedance with at most nine elements when the network is in series-parallel connections (the number is eight for a minimum function), the realization contains elements no more than those of Bott-Duffin's network. By duality and the transformation $s \leftrightarrow s^{-1}$, the other cases can also be proven. ■

Although the number of elements would be reduced by one through Pantell's synthesis [21], the configurations obtained would be bridge networks instead of series-parallel networks. In practice, the series-parallel mechanical networks have its own advantages than the bridge ones, such as requiring less space, ease of implementation, better durability, etc. Hence, we only consider series-parallel realizations in this brief.

B. Further Generalization to General Biquadratic Impedances

In this section, we further generalize the class to arbitrary biquadratic impedances. By duality and the frequency transformation $s \leftrightarrow s^{-1}$, we only need to concentrate on $Z(s)$ in the form of

$$Z(s) = H \frac{s^2 + a_1 s + a_0}{s^2 + b_1 s + b_0} \tag{6}$$

where $H, a_1, a_0, b_1, b_0 > 0$ and $a_0 > b_0$. Since $Z(s)$ should be positive-real and we assume that it does not satisfy the condition of Lemma 5, the coefficients should further satisfy

$$\frac{(\sqrt{a_0} - \sqrt{b_0})^2}{a_1} \leq b_1 < \frac{a_0 - b_0}{a_1}. \tag{7}$$

The next theorem presents the realization of this class.

Theorem 3: Consider a biquadratic impedance $Z(s)$ in the form of (6) where $H, a_1, a_0, b_1, b_0 > 0, a_0 > b_0$, and (7) are satisfied. Then, the realization procedure in the proof of Theorem 1 can be generalized to synthesize $Z(s)$ and the realization is the series-parallel network shown in Fig. 3(a) with at most nine elements. In particular, if $Z(s)$ is a minimum function, then the number of elements is at most eight.

Proof: In the proof of this theorem, we can assume that $a_1^2 - 4a_0 < 0$, i.e., the zeros are complex, since the case of $a_1^2 - 4a_0 \geq 0$ has been discussed in Theorem 1. Multiplying the numerator and denominator of $Z(s)$ by a common factor $(s + q)$ with $q > 0$, we obtain

$$\begin{aligned} Z(s) &= H \frac{s^3 + (q + a_1)s^2 + (a_1q + a_0)s + a_0q}{s^3 + (q + b_1)s^2 + (b_1q + b_0)s + b_0q} \\ &=: H \frac{m_1 + n_1}{m_2 + n_2} \end{aligned}$$

where $m_1 = (q + a_1)s^2 + a_0q, n_1 = s^3 + (a_1q + a_0)s, m_2 = (q + b_1)s^2 + b_0q$, and $n_2 = s^3 + (b_1q + b_0)s$. Decompose $Z(s)$ as $Z(s) = Z_1(s) + Z_2(s)$, where $Z_1(s) = Hn_2/(m_2 + n_2) = H(s^3 + (b_1q + b_0)s)/(s^3 + (q + b_1)s^2 + (b_1q + b_0)s + b_0q)$ and $Z_2(s) = H(m_1 + n_1 - n_2)/(m_2 + n_2) = H((q + a_1)s^2 + ((a_1 - b_1)q + (a_0 - b_0))s + a_0q)/(s^3 + (q + b_1)s^2 + (b_1q + b_0)s + b_0q)$. As discussed in the proof of Theorem 1, $Z_1(s)$ is realizable as a resistor in parallel with a lossless subnetwork consisting of two inductors and one capacitor, which comprises the left part of the network shown in Fig. 3(a). Removal of the pole of $Z_2^{-1}(s)$ at infinity gives $Z_2^{-1}(s) = s/(H(q + a_1)) + Z_3^{-1}(s)$, where $Z_3(s)$ is in the form of (4) with $\alpha_2 = H(q + a_1)^2, \alpha_1 = H((a_1 - b_1)q + (a_0 - b_0))(q + a_1), \alpha_0 = Ha_0q(q + a_1), \beta_2 = q^2 + 2b_1q + (a_1b_1 + b_0 - a_0), \beta_1 = b_1q^2 + (a_1b_1 + b_0 - a_0)q + a_1b_0$, and $\beta_0 = b_0q(q + a_1)$. Let $\alpha_2\beta_0 = \alpha_0\beta_2$; then, we obtain the following equation in q :

$$(a_0 - b_0)q^2 + 2(a_0b_1 - a_1b_0)q + (a_0a_1b_1 + a_0b_0 - a_0^2 - a_1^2b_0) = 0. \tag{8}$$

Using the similar method as the proof in Theorem 1, it can be proven that (8) has one and only one positive root q_0 because of $a_0 > b_0$ and (7). It is obvious that $\alpha_2, \alpha_0, \beta_0 > 0$ when $q = q_0$. The equation $\beta_2 = 0$ in q has one and only one positive root because of $a_1b_1 + b_0 - a_0 < 0$. To show $\beta_2 > 0$, it suffices to show that $q_1 < q_0$, where q_1 is the unique positive root of $\beta_2 = 0$ in q . Substituting $q_1^2 + 2b_1q_1 + (a_1b_1 + b_0 -$

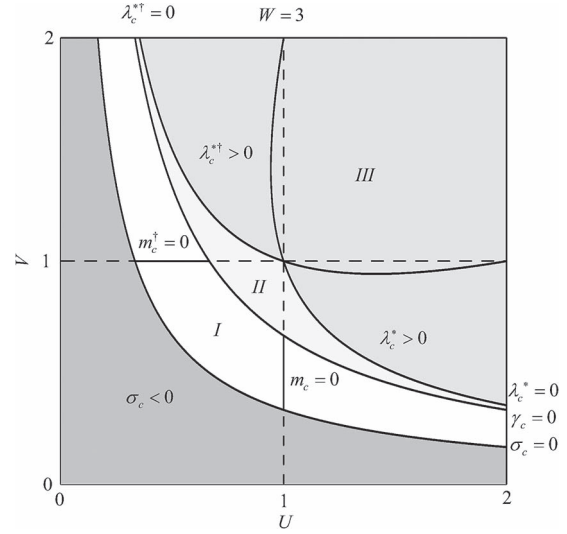

Fig. 4. U - V plane showing the conditions of the procedures in this brief and the work by Tirtoprodjo [24]. Region I corresponds to the condition of Theorem 3, Region II corresponds to the condition of Lemma 5 and being nonregular, and Region III corresponds to the condition of being regular. Line segments $m_c = 0$ and $m_c^* = 0$ correspond to the conditions of the biquadratic impedance in the work by Tirtoprodjo [24].

$a_0) = 0$ into the left-hand side of (8), i.e., $W(q_1) := (a_0 - b_0)q_1^2 + 2(a_0b_1 - a_1b_0)q_1 + (a_0a_1b_1 + a_0b_0 - a_0^2 - a_1^2b_0)$, it follows that $W(q_1) = 2b_0(b_1 - a_1)q_1 + b_0(a_1b_1 + b_0 - a_0 - a_1^2)$ and $W(q_1) = (b_0/b_1)(a_1 - b_1)q_1^2 - (a_1b_0/b_1)(a_0 - b_0)$. Hence, we assert that $W(q_1) < 0$, which shows that $q_1 < q_0$.

We regard $\beta_1 = b_1q^2 + (a_1b_1 + b_0 - a_0)q + a_1b_0$ as a quadratic function of q and use the similar method as the proof of Theorem 1, it can be proven that $\beta_1 > 0$ when $x_1 < b_1 < x_2$ and $q = q_0$ and that $\beta_1 = 0$ when $b_1 = x_1$ and $q = q_0$, i.e., $Z(s)$ is a minimum function.

Now, it is obvious that, to complete the proof of this theorem, it remains to show that $\alpha_1 > 0$ when $q = q_0$. For the case that $a_1 \geq b_1, \alpha_1 > 0$ when $q = q_0$ since $a_0 > b_0$. For the case that $a_1 < b_1$, let $q_m := (a_0 - b_0)/(b_1 - a_1)$. It is obvious that $\alpha_1 > 0$ when $q = q_0$, if and only if the left-hand side of (8) is positive, i.e., $W_1(q) = (a_0 - b_0)q^2 + 2(a_0b_1 - a_1b_0)q + (a_0a_1b_1 + a_0b_0 - a_0^2 - a_1^2b_0) > 0$, when $q = q_m$. This is equivalent to $W_1(b_1) = (a_1b_1 + a_0 - a_1^2 - b_0)W_2(b_1) > 0$, where $W_2(b_1) = a_0b_1^2 - a_1(a_0 + b_0)b_1 + (a_0^2 - 2a_0b_0 + a_1^2b_0 + b_0^2)$, whose discriminant is calculated as $(a_0 - b_0)^2(a_1^2 - 4a_0)$. Since it is assumed that $a_1^2 - 4a_0 < 0$, the equation $W_2(b_1) = 0$ in b_1 has no real root. Therefore, the equation $W_1(b_1) = 0$ in b_1 has one and only one real root, which is $(a_1^2 + b_0 - a_0)/a_1$. Thus, $W_1(b_1) > 0$ holds if and only if $b_1 > (a_1^2 + b_0 - a_0)/a_1 \Leftrightarrow a_0 - b_0 > a_1(a_1 - b_1)$, which is always satisfied as $a_1 < b_1$ and $a_0 > b_0$. Thus, $Z_3(s)$ can be realized with at most four elements (three elements for a minimum function). ■

Theorem 4: Consider a nonregular positive-real biquadratic impedance $Z(s)$ in the form of (1), where $A, B, C, D, E, F > 0$. Then, $Z(s)$ can be realized by the network shown in Fig. 2 through the method in the proof of Lemma 5 or by the network shown in Fig. 3 using the procedure outlined in Theorem 1 (or its dual or $s \leftrightarrow s^{-1}$). Furthermore, if the networks are to be realized in series-parallel connections, then the realization contains elements no more than those in Bott-Duffin’s network.

Proof: Considering Lemma 5 and Theorem 3, this theorem follows immediately through duality and the frequency transformation $s \leftrightarrow s^{-1}$. ■

We now use the U - V plane used in [17] to graphically compare the regions of conditions. Express $Z(s)$ in its canonical form as discussed in [17], i.e., $Z_c(s) = (s^2 + 2U\sqrt{W}s + W)/(s^2 + (2V/\sqrt{W})s + 1/W)$, where $U, V, W > 0$. For any rational function $\rho(U, V, W)$, we introduce the notations $\rho^*(U, V, W) = \rho(U, V, W^{-1})$ and $\rho^\dagger(U, V, W) = \rho(V, U, W)$. Let $\lambda_c = 4UV - 4V^2W - (1/W - W)$, $\gamma_c = 4UV - (W - 1/W)$, and $\sigma_c = 4UV - (1/W + W - 2)$. It is known in [17] that $Z(s)$ is positive-real if and only if $\sigma_c \geq 0$; the condition of Lemma 5 is satisfied if and only if $\gamma_c \geq 0$ when $W > 1$ and $\gamma_c^* \geq 0$ when $W \leq 1$; $Z(s)$ is regular if and only if $\lambda_c \geq 0$ or $\lambda_c^\dagger \geq 0$ when $W \leq 1$ and $\lambda_c^* \geq 0$ or $\lambda_c^{\dagger*} \geq 0$ when $W \geq 1$. Then, the conditions of using realization procedures can be expressed as a U - V plane when $W = 3$, which is as shown in Fig. 4. It is seen that the positive-real region is divided into Region I, Region II, and Region III, which correspond to the condition of Theorem 3, the condition of Lemma 5 and being nonregular, and the condition of being regular, respectively. The condition of the work by Tirtoprodjo only corresponded to the line segments in Region I. It is noted that this brief enlarges the case from those line segments to the entire Region I, which, together with Region II and Region III, forms the whole positive-real region.

III. CONCLUSION

This brief has discussed the realization of biquadratic impedances, motivated by the recent development in passive mechanical control. Tirtoprodjo [24] had proposed a procedure to realize the class of the biquadratic impedances with multiple real zeros (poles) and arbitrary poles (zeros). This brief has extended Tirtoprodjo's synthesis to realize arbitrary positive-real biquadratic impedances by providing a constructive synthesis procedure. The series-parallel network obtained contains elements no more than those in Bott-Duffin's network when the impedance is nonregular.

ACKNOWLEDGMENT

The authors would like to thank the Associate Editor and the reviewers for their insightful suggestions.

REFERENCES

- [1] B. D. O. Anderson and S. Vongpanitlerd, *Network Analysis and Synthesis: A Modern Systems Theory Approach*. Englewood Cliffs, NJ: Prentice-Hall, 1973.
- [2] H. Baher, *Synthesis of Electrical Networks*. New York: Wiley, 1984.
- [3] R. Bott and R. J. Duffin, "Impedance synthesis without use of transformers," *J. Appl. Phys.*, vol. 20, no. 8, p. 816, Aug. 1949.
- [4] M. Z. Q. Chen, "Passive network synthesis of restricted complexity," Ph.D. dissertation, Eng. Dept., Cambridge Univ., Cambridge, U.K., Aug. 2007.
- [5] M. Z. Q. Chen, C. Papageorgiou, F. Scheibe, F.-C. Wang, and M. C. Smith, "The missing mechanical circuit element," *IEEE Circuits Syst. Mag.*, vol. 9, no. 1, pp. 10–26, Mar. 2009.
- [6] M. Z. Q. Chen and M. C. Smith, "Electrical and mechanical passive network synthesis," in *Recent Advances in Learning and Control, Lecture Notes in Control and Information Sciences*, vol. 371, V. D. Blondel, S. P. Boyd, and H. Kimura, Eds. New York: Springer-Verlag, 2008, pp. 35–50.
- [7] M. Z. Q. Chen and M. C. Smith, "Restricted complexity network realizations for passive mechanical control," *IEEE Trans. Autom. Control*, vol. 54, no. 10, pp. 2290–2301, Oct. 2009.
- [8] M. Z. Q. Chen and M. C. Smith, "A note on tests for positive-real functions," *IEEE Trans. Autom. Control*, vol. 54, no. 2, pp. 390–393, Feb. 2009.
- [9] M. de la Sen, "A method for general design of positive real functions," *IEEE Trans. Circuits Syst. I, Fundam. Theory Appl.*, vol. 45, no. 7, pp. 764–769, Jul. 1998.
- [10] R. M. Foster and E. L. Ladenheim, "A class of biquadratic impedances," *IEEE Trans. Circuit Theory*, vol. CT-10, no. 2, pp. 262–265, Jun. 1963.
- [11] R. M. Foster, "Academic and theoretical aspects of circuit theory," *Proc. IRE*, vol. 50, no. 5, pp. 866–871, May 1962.
- [12] J. Gregor, "On the design of positive real functions," *IEEE Trans. Circuits Syst. I, Fundam. Theory Appl.*, vol. 43, no. 11, pp. 945–947, Nov. 1996.
- [13] E. A. Guillemin, *Synthesis of Passive Networks*. New York: Wiley, 1957.
- [14] M. Hakimi-Moghadam and H. Khaloozadeh, "Strict positive realness and its equivalent electrical networks," in *Proc. 23th Chin. Control Decis. Conf.*, May 2011, pp. 139–142.
- [15] J. Z. Jiang, "Passive electrical and mechanical network synthesis," Ph.D. dissertation, Eng. Dept., Cambridge Univ., Cambridge, U.K., Apr. 2010.
- [16] J. Z. Jiang and M. C. Smith, "Regular positive-real functions and the classification of transformerless series-parallel networks," in *Perspectives in Mathematical System Theory, Control, and Signal Processing*, vol. 398. New York: Springer-Verlag, 2010, pp. 15–25, LNCIS.
- [17] J. Z. Jiang and M. C. Smith, "Regular positive-real functions and five-element network synthesis for electrical and mechanical networks," *IEEE Trans. Autom. Control*, vol. 56, no. 6, pp. 1275–1290, Jun. 2011.
- [18] R. Kalman, "Old and new directions of research in system theory," in *Perspectives in Mathematical System Theory, Control, and Signal Processing*, vol. 398. New York: Springer-Verlag, 2010, pp. 3–13, LNCIS.
- [19] E. L. Ladenheim, "A synthesis of biquadratic impedances," M.S. thesis, Polytech. Inst. Brooklyn, New York, 1948.
- [20] H. J. Marquez and C. J. Damaren, "On the design of strictly positive real transfer functions," *IEEE Trans. Circuits Syst. I, Fundam. Theory Appl.*, vol. 42, no. 4, pp. 214–218, Apr. 1995.
- [21] R. H. Pantell, "A new method of driving-point impedance synthesis," *Proc. IRE*, vol. 42, no. 5, p. 861, May 1954.
- [22] P. Rocha, J. C. Willems, P. Rapisarda, and D. Napp, "On the stability of switched behavioral systems," in *Proc. 50th IEEE Conf. Decis. Control Eur. Control Conf.*, Orlando, FL, Dec. 12–15, 2011, pp. 1534–1538.
- [23] M. C. Smith, "Synthesis of mechanical networks: The inerter," *IEEE Trans. Autom. Control*, vol. 47, no. 10, pp. 1648–1662, Oct. 2002.
- [24] S. Tirtoprodjo, "Series-parallel RLC synthesis without minimisation for a class of biquadratic impedances," *Electron. Lett.*, vol. 8, no. 17, pp. 433–434, Aug. 1972.
- [25] C. G. Vasiliu, "Series-parallel six-element synthesis of the biquadratic impedances," *IEEE Trans. Circuit Theory*, vol. 17, no. 1, pp. 115–121, Feb. 1970.
- [26] K. Wang and M. Z. Q. Chen, "Realization of biquadratic impedances with at most four elements," in *Proc. 24th Chin. Control Decis. Conf.*, 2012, pp. 2888–2893.