



<b>Title</b>	<b>Reduction of Energy Storage Requirements in Future Smart Grid using Electric Springs</b>
<b>Author(s)</b>	<b>Lee, CK; Hui, SYR</b>
<b>Citation</b>	<b>IEEE Transactions on Smart Grid, 2013, v. 4 n. 3, p. 1282-1288</b>
<b>Issued Date</b>	<b>2013</b>
<b>URL</b>	<b><a href="http://hdl.handle.net/10722/184501">http://hdl.handle.net/10722/184501</a></b>
<b>Rights</b>	<b>Creative Commons: Attribution 3.0 Hong Kong License</b>

# Reduction of Energy Storage Requirements in Future Smart Grid Using Electric Springs

Chi Kwan Lee, *Member, IEEE*, and Shu Yuen (Ron) Hui, *Fellow, IEEE*

**Abstract**—The electric spring is an emerging technology proven to be effective in i) stabilizing smart grid with substantial penetration of intermittent renewable energy sources and ii) enabling load demand to follow power generation. The subtle change from output voltage control to input voltage control of a reactive power controller offers the electric spring new features suitable for future smart grid applications. In this project, the effects of such subtle control change are highlighted, and the use of the electric springs in reducing energy storage requirements in power grid is theoretically proven and practically demonstrated in an experimental setup of a 90 kVA power grid. Unlike traditional Statcom and Static Var Compensation technologies, the electric spring offers not only reactive power compensation but also automatic power variation in non-critical loads. Such an advantageous feature enables non-critical loads with embedded electric springs to be adaptive to future power grid. Consequently, the load demand can follow power generation, and the energy buffer and therefore energy storage requirements can be reduced.

**Index Terms**—Distributed power systems, energy storage, smart grid, stability.

## I. INTRODUCTION

THE EXISTING control paradigm of power systems is to generate power to meet the load demand, i.e., “power generation following load demand” [1], [2]. With the increasing use of intermittent renewable energy sources, known or unknown to the utility companies, it is impossible to determine the instantaneous total power generation in real time. In order to achieve balance of power supply and demand, which is an essential factor for power system stability, the control paradigm for future smart grid has to be shifted to “load demand following power generation” [3], [4].

Various load demand management methods have previously been proposed. Some examples include load scheduling [5]–[7], use of energy storage as a buffer [8], electricity pricing [9]–[11], direct control or on-off control of smart loads [12]–[14], etc.

Manuscript received June 07, 2012; revised September 03, 2012; accepted March 03, 2013. Date of publication April 12, 2013; date of current version August 21, 2013. This work was supported by the HK Research Grant Council under the Collaborative Research Fund HKU10/CRF/10, University of Hong Kong (Seed Projects: 201111159239 & 201203159010), and Imperial College London. Paper no. TSG-00345-2012.

C. K. Lee is with the Department of Electrical & Electronic Engineering, University of Hong Kong, Pokfulam, Hong Kong, China (e-mail: cklee@eee.hku.hk).

S. Y. Hui is with the Department of Electrical & Electronic Engineering, University of Hong Kong, Pokfulam, Hong Kong, China, and also with Imperial College London, London SW7 2AZ, U.K. (e-mail: ronhui@eee.hku.hk; r.hui@imperial.ac.uk).

Color versions of one or more of the figures in this paper are available online at <http://ieeexplore.ieee.org>.

Digital Object Identifier 10.1109/TSG.2013.2252208

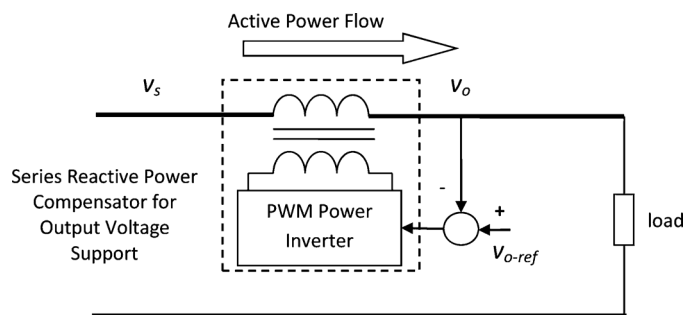

Fig. 1. “Output voltage control” of a series reactive power compensator.

However, most of these methods are suitable for load demand management in the time frame of hours and are not suitable for instantaneous energy balance in real time. Energy storage is probably the most effective means for instantaneous energy balancing [8]. In order to cope with fast transient, energy storage elements such as battery banks are installed with parallel connected super-capacitors which can absorb current at a faster rate than chemical batteries [15]. However, energy storage elements such as batteries are expensive and disposed batteries are major sources of pollutants. Although they are considered to be essential elements in future smart grid [15], it would be preferable to reduce their size for cost and environmental reasons.

In this project, an investigation is conducted to examine the use of electric springs in reducing energy storage elements in future smart grid. The electric spring concept [16], [17] was recently presented as a new smart grid technology for regulating the mains voltage of power grid with substantial intermittent renewable power and for achieving the new control paradigm of load demand following power generation. Traditional series reactive power compensators use output voltage control (Fig. 1); by shifting from the output voltage control to the input voltage control for a reactive power controller, electric springs demonstrate characteristics different from traditional devices such as series reactive power controller. The effects of this subtle change of control methodology and the interactions between the electric springs and energy storage in a power grid, which have not been previously addressed, are highlighted with practical tests in this project. Unlike Statcom, Static Var Compensation, and UPFC technologies [21]–[26], electric springs offer not only reactive power compensation, but also automatic load variation in non-critical loads (with electric springs embedded). This advantageous feature provides the possibility of reducing energy storage requirements in future smart grid. This important point is first theoretically proved and then practically demonstrated in a 10 kVA experimental smart grid setup.

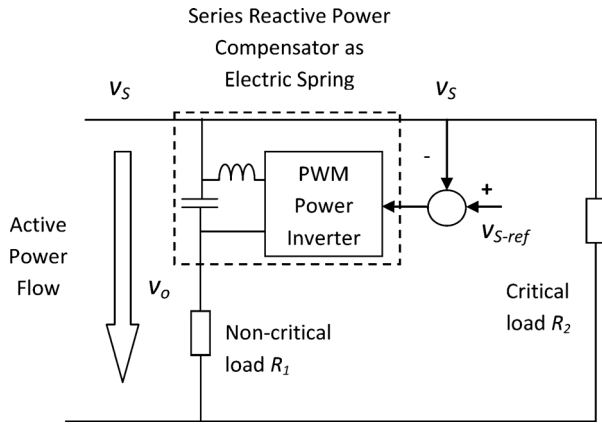

Fig. 2. Arrangement of an electric spring connected in series with a non-critical load (using the "input voltage control") [18].

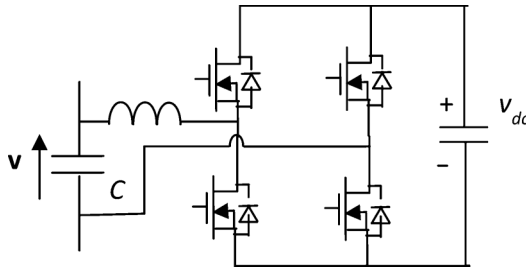

Fig. 3. Power inverter used as a reactive power controller.

## II. BASIC PRINCIPLES OF ELECTRIC SPRINGS

Electric springs are reactive power controllers with input voltage control instead of the traditional output voltage control used in series reactive power compensators. Details of the system operation can be found in [17]. In this session, the basic principles of electric springs are summarized so as to facilitate readers' understanding of the power flow analysis and the effects of the electric springs on reducing energy storage requirements in smart grid.

Fig. 2 shows a typical installation of a single-phase electric spring connected in series with a non-critical load. The electric spring comprises a power inverter with a dc bulk capacitor on the dc side and an inductive-capacitive (LC) filter on the ac side of the power inverter (Fig. 3). The four freewheeling diodes of the power inverter behave like a diode rectifier which rectifies the ac voltage into a dc one ( $V_{dc}$ ) across the bulk capacitor. The pulse-width-modulation switching method is adopted in the power inverter to generate a controllable ac voltage  $v_a$  across the filter capacitor. This controllable ac voltage is the output voltage of the electric spring. For pure reactive power control, the vector of the electric spring voltage and the current must be perpendicular. The input voltage control loop depicted in Fig. 2 is designed to generate  $v_a$  dynamically with the purposed of regulating the ac mains voltage to a reference value.

The vector equation for the electric spring is:

$$v_o = v_s - v_a. \quad (1)$$

Assuming that a certain time-varying power generation  $P_{in}$ , which may consist of a base power profile (generated by an ac generator) and an intermittent renewable power profile, is fed

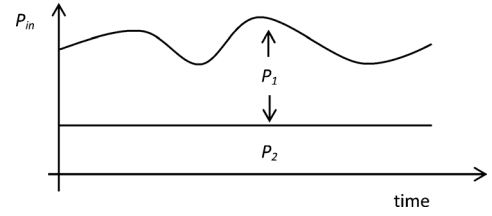

Fig. 4. Power profiles of non-critical load ( $P_1$ ) and critical load ( $P_2$ ) when the mains voltage  $v_s$  is regulated by the reactive power controller [17].

to the distribution line in Fig. 2, the power balance equation can be expressed as

$$P_{in} = \frac{v_s^2 - v_a^2}{R_1} + \frac{v_s^2}{R_2} \quad (2)$$

$$P_{in} = P_1 + P_2$$

where  $R_1$  and  $P_1$  are the resistance and power consumption of the non-critical load respectively; and  $R_2$  and  $P_2$  are the resistance and power consumption of the critical load respectively;  $v_s$  and  $v_a$  are the root-mean-square values of the ac mains and electric spring voltage respectively.

Renewable energy sources can be wind and solar energy sources. Non-critical loads refer to electric equipment and appliances that can be subject to a fairly large variation of the mains voltage. Examples include electric heaters, refrigerators and lighting systems. Critical loads refer to electric loads that require a well-regulated mains voltage, such as life-supporting medical equipment and computer controlled equipment.

Equation (2) indicates that, if the electric spring can regulate  $v_s$ ,  $P_2$  should be constant and  $P_1$  should follow the time-varying profile of the intermittent power generation as shown in Fig. 4.

Let the rated power of the non-critical load when the electric spring is not activated (i.e.,  $v_a = 0V$ ) be:

$$P_1^{\max} = \frac{v_s^2}{R_1} \quad (3)$$

where  $v_s$  is at its nominal rated value.

Let the actual power of the non-critical load power under the control of electric spring (i.e.,  $v_a \geq 0V$ ) be

$$P_1^{es} = \frac{v_s^2 - v_a^2}{R_1}. \quad (4)$$

It is clear from (3) and (4) that:

$$P_1^{\max} \geq P_1^{es}. \quad (5)$$

Equation (4) and (5) reflect the fact that the electric spring can vary the non-critical load power so that the load demand follows the power generation.

## III. POWER ANALYSIS OF ELECTRIC SPRINGS FOR REDUCTION OF ENERGY STORAGE

Now consider a general power grid consisting of an ac generator, a renewable power source, energy storage (battery banks), a set of non-critical loads and a set of critical loads as shown in Fig. 5 The power flow diagram is shown in Fig. 6 in which

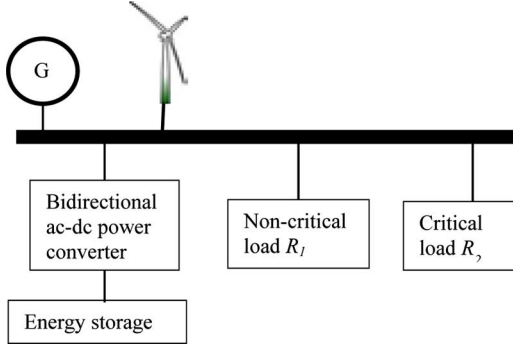

Fig. 5. Schematic of a power grid.

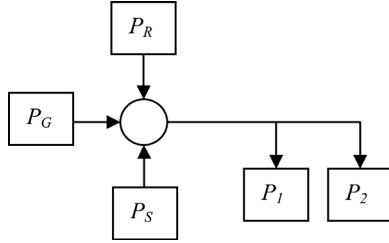

Fig. 6. Power flow diagram.

the power from the energy storage can be positive or negative depending on whether the storage device is discharging or charging.

The power balance equation of the power grid in Fig. 6 can be expressed as:

$$P_G + P_R + P_S = P_1 + P_2 \quad (6)$$

where  $P_G$  is the power generated by the ac generator,  $P_R$  is the renewable power, and  $P_S$  is the power from the energy storage.  $P_S$  is positive when the battery is discharging and negative when it is charging.

Re-arranging (6) with the storage power as the subject of the equation,

$$P_S = -P_G - P_R + P_1 + P_2. \quad (7)$$

Without the electric spring, the energy storage requirement for a duration of  $T$  is:

$$E_S = \int_0^T P_S dt = - \int_0^T P_G dt - \int_0^T P_R dt + \int_0^T P_1^{\max} dt + \int_0^T P_2 dt. \quad (8)$$

With the electric spring, the energy storage requirement for the same duration is:

$$E_S^{es} = \int_0^T P_S dt = - \int_0^T P_G dt - \int_0^T P_R dt + \int_0^T P_1^{es} dt + \int_0^T P_2 dt. \quad (9)$$

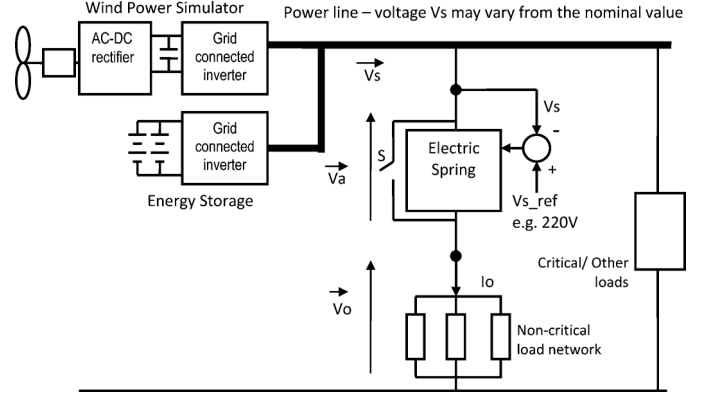

Fig. 7. Experimental setup based on the 90 kVA Smart Grid Hardware Simulation System at the Maurice Hancock Smart Energy Laboratory.

The difference of the energy storage requirements with and without the electric spring can be obtained by subtracting (8) from (9), resulting in:

$$E_S - E_S^{es} = \int_0^T P_1^{\max} dt - \int_0^T P_1^{es} dt. \quad (10)$$

In view of (5),

$$\int_0^T P_1^{\max} dt \geq \int_0^T P_1^{es} dt. \quad (11)$$

Therefore,

$$E_S \geq E_S^{es}. \quad (12)$$

Equation (12) shows that the use of the electric spring can theoretically reduce the energy storage requirements in the power grid.

## IV. PRACTICAL EVALUATION

### A. Experimental Setup

With the mathematical proof in the previous section that electric springs have the potential of reducing energy storage requirements, a practical smart grid setup has been developed in the Maurice Hancock Smart Energy Laboratory. Fig. 7 shows the structure of the setup, which includes a hardware wind power simulator, a battery bank with a grid connected inverter, a non-critical load and a critical load. The nominal voltage value is set at 220 V. The non-critical load is represented by a resistive-inductive load bank of  $27.5 + j23.5 \Omega$ , and a resistive bank of  $31 \Omega$  is used as the critical load.

The wind power simulator is based on a programmable 90kVA commercial (Triphase) power inverter. It provides the sum of a base power (from the ac generator) and wind power (derived from a recorded dynamic wind profile). It injects time-varying power into the grid. A second commercial (Triphase) grid-connected power inverter of 10 kVA rating is used to link a battery bank (with capacity of 208 V, 45 Ah) installed in the Smart Energy Laboratory to the grid. This

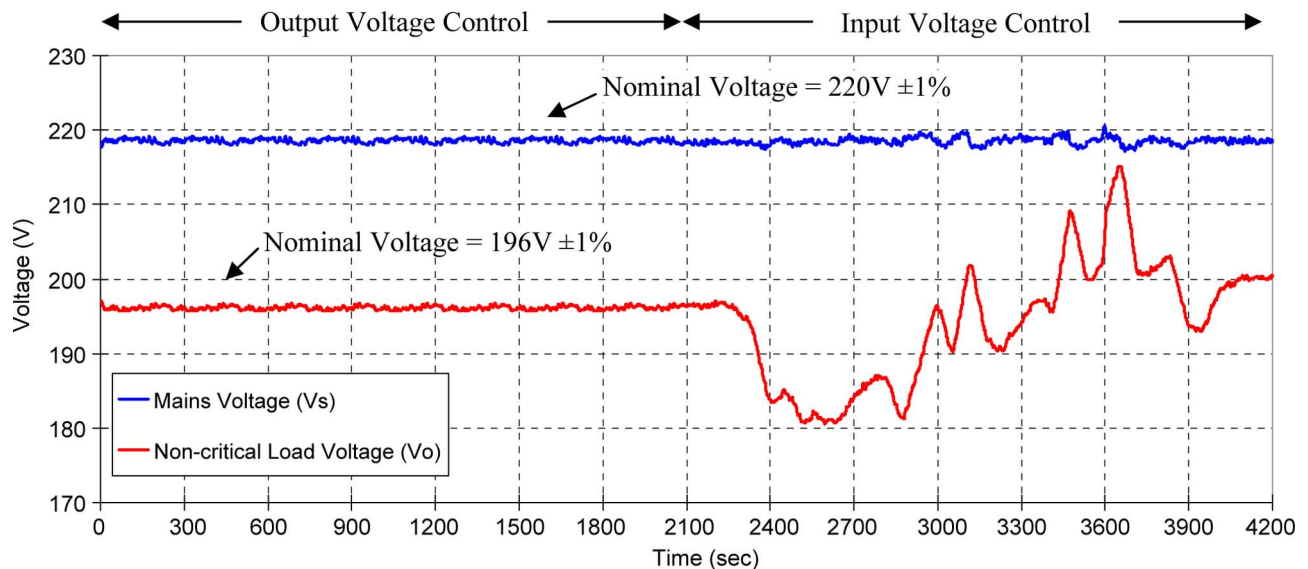

Fig. 8. Measured rms power line voltage ( $v_s$ ) and non-critical load voltage ( $v_o$ ).

bi-directional power converter system has an ac-dc conversion stage followed by a dc-dc conversion stage. The dc-dc converter provides the charging and discharging functions for the battery bank. However, it should be noted that the energy storage capacity is based on the existing battery installation in the Laboratory and should not be considered to be an optimized value.

An electric spring, which has an input voltage control loop, is connected in series with the non-critical load to regulate the mains voltage at the nominal rms value of 220 V. If the power generation is sufficient to meet the load demand and the mains voltage is ideally set at the nominal value of 220 V, the maximum power consumption of the non-critical and critical loads is approximately 2.6 kW. However, this is not necessarily the case as the renewable power may vary.

Due to the intermittent nature of the dynamic wind profile, the mains voltage is not stable, but consists of voltage ripples caused by the fluctuations of the wind speed. With the help of the bidirectional power converter, the battery bank can in principle help stabilize the mains voltage variation. In order to evaluate the effects of the input voltage control (which is the unique feature of the electric spring) on the energy storage requirement of the battery bank, electric power based on the pre-recorded wind profile of an interval of 2100 seconds is injected into the power grid twice: with the output voltage control (i.e., regulating  $v_o$  as in Fig. 1) of the reactive power controller in the first time interval and then with the input voltage control (i.e., regulating  $v_s$  as in Fig. 2) in the second interval.

### B. Practical Measurements

1) *Effects of Input Voltage and Output Voltage Control:* For the first time interval of 2100 s, the output voltage control (traditionally used in reactive power controller) is used to regulate the output voltage  $v_o$  to 196 V as planned. The rms value of  $v_o$  remains stable within 1% tolerance because of the output voltage control. The rms value of  $v_s$  is stable at 219 V, which

is also within 1% tolerance because of the voltage smoothing function of the energy storage. The measurements of  $v_s$  and  $v_o$  are recorded in Fig. 8.

In the second time interval from 2100 s to 4200 s, the control scheme is switched to the input voltage control. It can be seen from Fig. 8 that the mains voltage  $v_s$  is still regulated to the nominal value within 1% tolerance and the voltage  $v_o$  (the non-critical load voltage) is allowed to fluctuate according to (2).

2) *Effects On Non-critical Load Power and the Charging & Discharging of the Battery Bank:* The wind power injected into the grid, the charging and discharging power of the battery bank and the non-critical load power are measured and recorded for the two time intervals in Fig. 9. It can be seen that the wind power is not steady because of the intermittent wind profile. In the first time interval using output voltage control, the non-critical load power remains stable as its voltage  $v_o$  is stable (as shown in Fig. 8). The reason that the mains voltage  $v_s$  is stable is due to the charging and discharging of the battery bank. The charging and discharging power profile in the first time interval of Fig. 9 has a waveform that is opposite to the wind power variations. Therefore, it counteracts the wind power variations so that constant power is supplied to the non-critical load in the first time interval. This point is proved by the constant  $v_o$  and constant non-critical load power in the first time interval of Figs. 8 and 9, respectively.

The input voltage control used in the second time interval enables  $v_o$  to fluctuate as shown in Fig. 8. Such non-critical load voltage fluctuation in turn allows the non-critical load power to vary as can be seen in Fig. 9. It is important to note that the variation profile of the non-critical load power follows the variation of the wind power profile in Fig. 9. This important point means that the mains voltage is now regulated by both the electric spring (with input voltage control) and the battery bank. Because the electric spring shares the task of balancing the power supply and demand, the amount of charging and discharging power of the battery bank can be reduced. This is reflected by

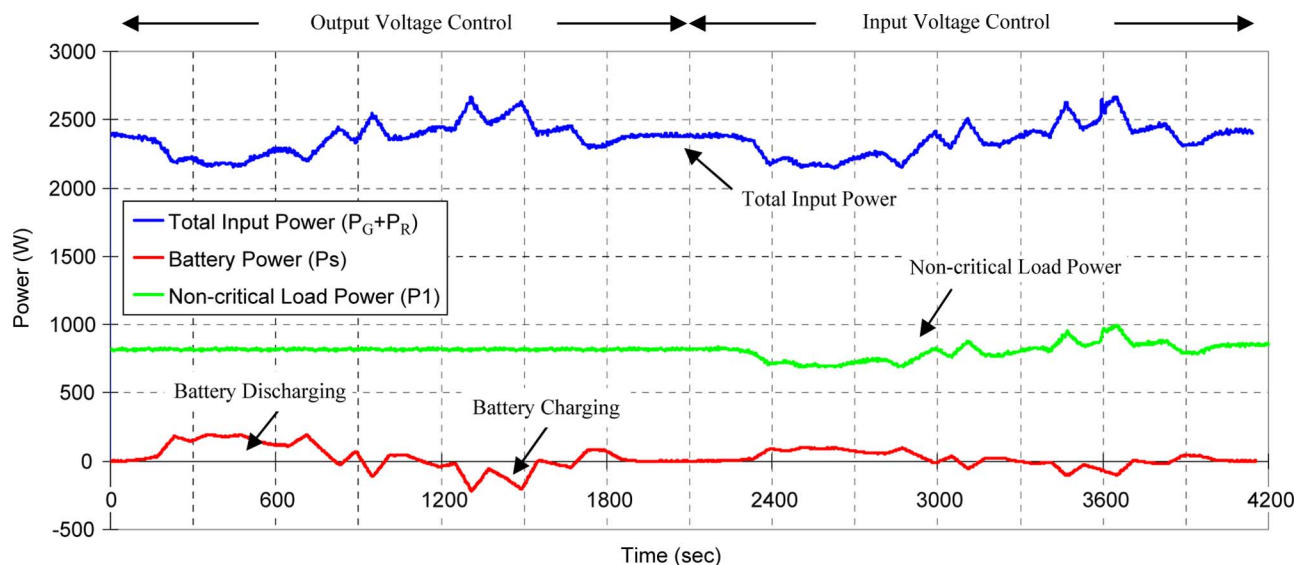

Fig. 9. Measured average powers of the wind power simulator ( $P_G + P_R$ ), battery storage ( $P_S$ ) and non-critical load ( $P_1$ ).

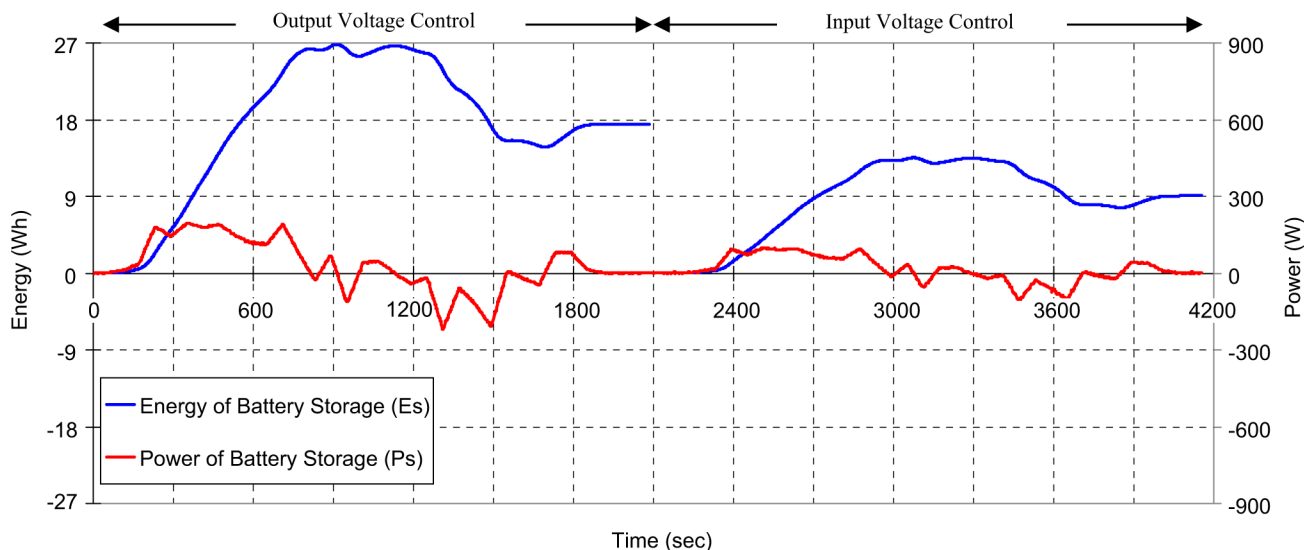

Fig. 10. Measured power ( $P_s$ ) and energy change ( $E_s$ ) of the battery storage.

the fact that the charging and discharging power profile in the first time interval is much larger than that in the second interval in Fig. 9.

3) *Voltage Variations On the Non-critical Load:* The variation of ac voltage ( $v_o$ ) for the non-critical load in Fig. 8 is not negligible. The voltage ripple can be as high as 10% of the nominal voltage. Therefore, only electric loads that can tolerate a certain degree of mains voltage fluctuation should be chosen as non-critical loads. Examples of non-critical loads are electric water heaters and electric heating systems. Lighting systems are usually designed to work with 180 V to 265 V. Therefore, public lighting systems such as those used in car parks, corridors, and stairways of buildings can be considered to be non-critical loads.

In addition, power electronics researchers are working on new smart electric loads that are adaptive to future grid with substantial voltage variation. For example, a new generation of large-scale smart LED lighting systems able to tolerate large voltage variations of at least 40 V without causing noticeable

light fluctuation has been reported in [27]. With new smart load research based on power electronics technology, it is envisaged that more smart electric loads such as smart refrigerators and fan drives that are adaptive to mains voltage fluctuations will be developed in the near future. For electric appliances that are sensitive to mains voltage variations, they should be considered as critical loads.

4) *Comparison on Energy Storage Requirement:* The charging and discharging profiles of the battery banks in the two time intervals are converted into energy profiles and plotted in Fig. 10. The energy storage requirement, namely the Watt-hour (Wh) value, of the battery bank for the two intervals are computed by integrating the charging and discharging power with time. In this practical example, the maximum Wh value without using input voltage control in the first interval is approximately 27 Wh. With the use of electric springs, the energy requirement can be reduced to approximately 13.5 Wh. Therefore, a reduction of 50% in energy storage requirement

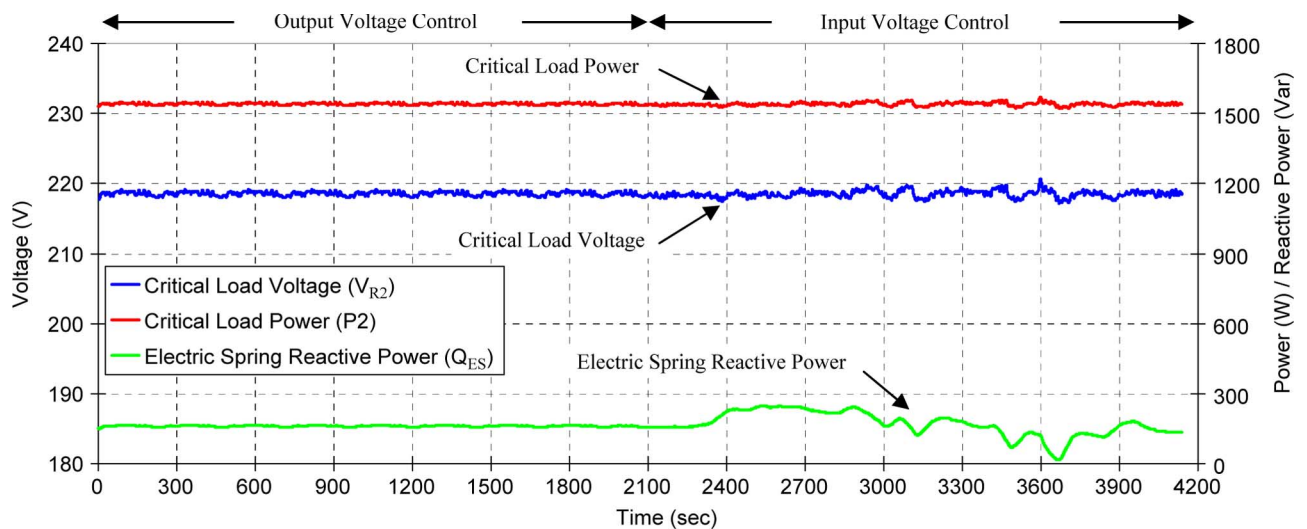

Fig. 11. Measured electric spring reactive power ( $Q_{ES}$ ), critical load voltage ( $V_{R2}$ ) and power ( $P2$ ).

has been achieved in this example. These measurements confirmed the theoretical prediction stated in (12).

5) *Reactive Power of Electric Spring*: Fig. 11 shows the variation of the reactive power of the electric spring in relation to the output voltage and input voltage control. It should be noted that the reactive power profile of the electric spring under the input voltage control follows the charging and discharging profile of the battery shown in Fig. 10. This means that both the battery and electric spring are working together in balancing the power supply and demand. Because of the energy-balancing role played by the electric spring, the energy storage requirements of the battery can be reduced.

The voltage and power of the critical load are also included in Fig. 11. It is clear that the voltage stays within the 1% tolerance of 220 V and the power for the critical load remains essentially constant within tight tolerance. The results confirm that the electric spring provides reactive power control of the non-critical load and reduces energy storage without affecting the critical load operation.

## V. CONCLUSIONS

In this paper, the differences between the output voltage control and the input voltage control of a reactive power controller are highlighted. While energy storage is an effective but expensive means to balance power supply and demand, an analysis and practical confirmation are presented to show that electric springs can reduce energy storage requirements in a power grid. Electric springs allow the non-critical load power to vary with the renewable energy profile. By reducing the instantaneous power imbalance of power supply and demand, electric springs allow the non-critical load demand profile to follow the power generation profile and reduce the energy storage requirements in power grid. This important point has been theoretically proved and practically verified in an experimental setup. Due to the advantageous features such as enabling the load demand to follow the power generation, the reduction of energy storage requirements, the reactive power compensation for voltage regulation, and the possibility of both active and reactive power

control [28], electric springs open a door to distributed stability control for future smart grid with substantial penetration of intermittent renewable energy sources.

## ACKNOWLEDGMENT

The authors gratefully acknowledge the help of Dr. Richard Silversides and Mr. Nathaniel Bottrell of Imperial College London in the setup of the power grid test bed. The authors would like to thank the Department of Electrical & Electronic Engineering, Imperial College London for providing the facilities in the Maurice Hancock Smart Energy Laboratory. The authors also thank the University of Hong Kong and Imperial College London for supporting the patent applications of the inventions.

## REFERENCES

- [1] D. Westermann and A. John, "Demand matching wind power generation with wide-area measurement and demand-side management," *IEEE Trans. Energy Convers.*, vol. 22, no. 1, pp. 145–149, 2007.
- [2] P. Palensky and D. Dietrich, "Demand side management: Demand response, intelligent energy systems, and smart loads," *IEEE Trans. Ind. Inform.*, vol. 7, no. 3, pp. 381–388, 2011.
- [3] P. Varaiya, F. Wu, and J. Bialek, "Smart operation of smart grid: Risk-limiting dispatch," *Proc. IEEE*, vol. 99, no. 1, pp. 40–57, 2011.
- [4] I. Koutsopoulos and L. Tassioulas, "Challenges in demand load control for the smart grid," *IEEE Netw.*, vol. 25, no. 5, pp. 16–21, 2011.
- [5] A. Mohsenian-Rad, V. W. S. Wong, J. Jatskevich, R. Schober, and A. Leon-Garcia, "Autonomous demand-side management based on game-theoretic energy consumption scheduling for the future smart grid," *IEEE Trans. Smart Grid*, vol. 1, no. 3, pp. 320–331, 2011.
- [6] M. Parvania and M. Fotuhi-Firuzabad, "Demand response scheduling by stochastic SCUC," *IEEE Trans. Smart Grid*, vol. 1, no. 1, pp. 89–98, 2010.
- [7] M. Pedrasa, T. D. Spooner, and I. F. MacGill, "Scheduling of demand side resources using binary particle swarm optimization," *IEEE Trans. Power Syst.*, vol. 24, no. 3, pp. 1173–1181, 2009.
- [8] P. Kienzle and G. Andersson, "Valuing investments in multi-energy conversion, storage, and demand-side management systems under uncertainty," *IEEE Trans. Sustainable Energy*, vol. 2, no. 2, pp. 194–202, 2011.
- [9] A. J. Conejo, J. M. Morales, and L. Baringo, "Real-time demand response model," *IEEE Trans. Smart Grid*, vol. 1, no. 3, pp. 236–242, 2010.
- [10] A.-H. Mohsenian-Rad and A. Leon-Garcia, "Optimal residential load control with price prediction in real-time electricity pricing environments," *IEEE Trans. Smart Grid*, vol. 1, no. 2, pp. 120–133, 2010.

- [11] A. J. Roscoe and G. Ault, "Supporting high penetrations of renewable generation via implementation of real-time electricity pricing and demand response," *IET Renewable Power Gener.*, vol. 4, no. 4, pp. 369–382, 2010.
- [12] S. C. Lee, S. J. Kim, and S. H. Kim, "Demand side management with air conditioner loads based on the queuing system model," *IEEE Trans. Power Syst.*, vol. 26, no. 2, pp. 661–668, 2011.
- [13] G. C. Heffner, C. A. Goldman, and M. M. Moezzi, "Innovative approaches to verifying demand response of water heater load control," *IEEE Trans. Power Del.*, vol. 21, no. 1, pp. 388–397, 2006.
- [14] A. Brooks, E. Lu, D. Reicher, C. Spirakis, and B. Wehl, "Demand dispatch," *IEEE Power Energy Mag.*, vol. 8, no. 3, pp. 20–29, 2010.
- [15] H. Kanchev, D. LuF, ColasV, Lazarov, and B. Francois, "Energy management and operational planning of a microgrid with a PV-based active generator for smart grid applications," *IEEE Trans. Ind. Electron.*, vol. 58, no. 10, pp. 4583–4592, 2011.
- [16] S. Y. R. Hui, C. K. Lee, and F. F. Wu, "Power control circuit and method for stabilizing a power supply," PCT Patent Application 61/389,489, Oct. 4, 2010.
- [17] S. Y. R. Hui, C. K. Lee, and F. F. Wu, "Electric springs — a new smart grid technology," *IEEE Trans. Smart Grid*, vol. 3, no. 3, pp. 1552–1561, Sep. 2012.
- [18] W. Casson and H. J. Sheppard, "Technical and economic aspects of the supply of reactive power in England and Wales," *Proc. IEE Part A, Power Eng.*, vol. 108, no. 42, pp. 507–526W, 1961.
- [19] J. Dixon, L. Moran, and J. Rodriguez, "Reactive power compensation technologies: State-of-the-art review," *Proc. IEEE*, vol. 93, no. 12, pp. 2144–2164, 2005.
- [20] H. K. Tyll and F. Schettle, "Historical overview on dynamic reactive power compensation solutions from the begin of ac power transmission towards present applications," in *Proc. IEEE Power Syst. Conf. Expo. (PSCE '09)*, pp. 1–7.
- [21] P. Sauer, "Reactive power and voltage control issues in electric power systems," *Appl. Math. Restructured Elect. Power Syst.*, pp. 11–24, 2005.
- [22] Y. Rong, C. Li, H. Tang, and X. Zheng, "Output feedback control of single-phase UPQC based on a novel model," *IEEE Trans. Power Del.*, vol. 24, no. 3, pp. 1586–1597, 2009.
- [23] H. Fujita, Y. Watanabe, and H. Akagi, "Control and analysis of a unified power flow controller," *IEEE Trans. Power Electron.*, vol. 14, no. 6, pp. 1021–1027, 1999.
- [24] K. Sen and E. J. Stacey, "UPFC-unified power flow controller: theory, modeling, and applications," *IEEE Trans. Power Del.*, vol. 13, no. 4, pp. 1453–1460, 1998.
- [25] S. Kannan, S. Jayaram, and M. Salama, "Real and reactive power coordination for a unified power low controller," *IEEE Trans. Power Syst.*, vol. 19, no. 3, pp. 1454–1461, 2004.
- [26] Y. Kim, J. S. Kim, and S. H. Ko, "Three-phase three-wire series active power filter, which compensates for harmonics and reactive power," *IEE Proc.—Elect. Power Appl.*, vol. 151, no. 3, pp. 276–282, 2004.
- [27] C. K. Lee and S. Y. R. Hui, "A design methodology for smart LED lighting systems driven by weakly-regulated power grids," *IEEE Trans. Smart Grid*, vol. 2, no. 3, pp. 548–554, Sep. 2011.
- [28] S. C. Tan, C. K. Lee, and S. Y. R. Hui, "General steady-state analysis and control principle of electric springs with active and reactive power compensations," *IEEE Trans. Power Electron.*, vol. 28, no. 8, pp. 3958–3969, Aug. 2013.



**Chi Kwan Lee** (M'08) received the B.Eng. and Ph.D. degrees in electronic engineering from the City University of Hong Kong, Kowloon, Hong Kong, in 1999 and 2004, respectively.

He was a Postdoctoral Research Fellow in the Power and Energy Research Centre at the National University of Ireland, Galway, from 2004 to 2005. In 2006, he joined the Centre of Power Electronics in City University of Hong Kong as a Research Fellow. In 2008–2011 he was a Lecturer of Electrical Engineering at the Hong Kong Polytechnic University.

He was a Visiting Academic at Imperial College London, U.K., in 2010–2011. Since January 2012, he has been an Assistant Professor at the Department of Electrical & Electronic Engineering, the University of Hong Kong. His current research interests include applications of power electronics to power systems, advanced inverters for renewable energy and smart grid applications, reactive power control for load management in renewable energy systems, wireless power transfer, energy harvesting and planar electromagnetics for high frequency power converters. He is a co-inventor of the electric springs and a planar EMI filter.



**S. Y. (Ron) Hui** (M'87–SM'94–F'03) received his B.Sc. (Eng) Hons at the University of Birmingham, U.K., in 1984 and a D.I.C. and Ph.D. at Imperial College London, U.K., in 1987.

He previously held academic positions at the University of Nottingham, U.K. (1987–90), the University of Technology, Sydney, Australia (1990–91), the University of Sydney (1992–96), and the City University of Hong Kong (1996–2011). Currently, he is the holder of the Philip Wong Wilson Wong Chair Professorship at the University of Hong Kong. Since

July 2010, he has concurrently held the Chair Professorship of Power Electronics at Imperial College London. He has published over 200 technical papers, including more than 160 refereed journal publications and book chapters. Over 55 of his patents have been adopted by industry.

Dr. Hui is a Fellow of the IET. He has been an Associate Editor of the IEEE TRANSACTIONS ON POWER ELECTRONICS since 1997 and an Associate Editor of the IEEE TRANSACTIONS ON INDUSTRIAL ELECTRONICS since 2007. He has been appointed twice as an IEEE Distinguished Lecturer by the IEEE Power Electronics Society in 2004 and 2006. He served as one of the 18 Administrative Committee members of the IEEE Power Electronics Society and was the Chairman of its Constitution and Bylaws Committee from 2002–2010. He received the Teaching Excellence Award in 1998 and the Earth Champion Award in 2008. He won an IEEE Best Paper Award from the IEEE IAS Committee on Production & Applications of Light in 2002, and two IEEE Power Electronics Transactions Prize Paper Awards for his publications on Wireless Charging Platform Technology in 2009 and on LED System Theory in 2010. His inventions on wireless charging platform technology underpin key dimensions of Qi, the world's first wireless power standard, with freedom of positioning and localized charging features for wireless charging of consumer electronics. He is a co-inventor of the electric springs. In November 2010, he received the IEEE Rudolf Chope R&D Award from the IEEE Industrial Electronics Society, the IET Achievement Medal (The Crompton Medal) and was elected to the Fellowship of the Australian Academy of Technological Sciences & Engineering.