

Bachelor's Thesis

Degree programme in Information Technology

2010

Weichi Zhang

# **DESIGN CONSIDERATIONS OF IMPLEMENTING A MOBILE WIRELESS LOCAL AREA NETWORK**

**- CASE STUDY: "GOD'S EYES" VIDEO  
SURVEILLANCE SYSTEM**



**TURUN AMMATTIKORKEAKOULU**  
TURKU UNIVERSITY OF APPLIED SCIENCES

BACHELOR'S THESIS (UAS) | ABSTRACT

TURKU UNIVERSITY OF APPLIED SCIENCES

Degree programme in Information Technology

Spring 2010 | 41

Advisor(s)

Zhang Weichi

## Abstract

Benefitting from the mobility of cellular network and broadband internet services of wireless network, people are demanding to access internet ubiquitously. The telecommunication operators are considering Wireless Local Area Network technology to be complementary to the third generation telecommunication technology.

This thesis is aiming to discover the design considerations of implementing Mobile Wireless Local Area Network which is the integration of mobile telephone network and wireless local area network. Firstly, it introduces different standards and system structures throughout the evolution of cellular technology. Secondly, it focuses on the key issues of implementing Wireless Local Area Network. Then, the argument of integrating 3G and WLAN is examined by comparing the technical details of these two standards which are the most popular wireless technologies nowadays. Finally, a detailed implementation plan of video surveillance system over mobile wireless local area network is presented.

### KEYWORDS:

Mobile Telephone Network, Wireless LAN, Mobile Wireless LAN, Video Surveillance System

<b>TABLE OF CONTENTS</b>	
<b>ACRONYMS AND ABBREVIATIONS</b>	<b>V</b>
<b>1 INTRODUCTION</b>	<b>1</b>
<b>2 OVERVIEW OF MOBILE TELEPHONE NETWORK</b>	<b>2</b>
<b>2.1 Analog Cellular System</b>	<b>3</b>
<b>2.2 Digital Cellular System</b>	<b>4</b>
2.2.1 GSM	4
2.2.2 CDMA	5
2.2.3 GPRS	6
<b>2.3 The 3G</b>	<b>6</b>
2. 3.1 WCDMA	6
2. 3.2 CDMA 2000	7
2. 3.3 TD-SCDMA	8
2. 3.4 WiMax	9
<b>3 OVERVIEW OF WIRELESS LOCAL AREA NETWORK</b>	<b>11</b>
<b>3.1 IEEE Standards</b>	<b>11</b>
<b>3.2 Network Architecture</b>	<b>12</b>
<b>3.3 WLAN Frame Transmission</b>	<b>16</b>
<b>3.4 Authentication and Security</b>	<b>17</b>
<b>4 DESIGNING A MOBILE WIRELESS LOCAL AREA NETWORK</b>	<b>19</b>
<b>4. 1 Comparison of 3G and WLAN</b>	<b>19</b>
<b>4. 2 Interworking architectures of MWLAN</b>	<b>21</b>
4.2.1 Loose Coupling Model	21
4.2.2 Tight Coupling Model	22
<b>4. 3 Rules and Approaches of Designing MWLAN</b>	<b>23</b>
4.3.1 Rules of Designing	23
4.3.2 Approaches of Designing	24
<b>4. 4 Applications of MWLAN</b>	<b>25</b>
<b>5 CASE STUDY</b>	<b>27</b>
<b>5. 1 GEVSS over MWLAN</b>	<b>27</b>
<b>5. 2 Project Plan</b>	<b>28</b>
<b>5. 3 System Network Structure</b>	<b>29</b>
<b>5. 4 Performance Showcase</b>	<b>30</b>

<b>6 SUMMARY</b>	<b>33</b>
<b>REFERENCES</b>	<b>34</b>
<b>APPENDIX</b>	<b>37</b>

## ACRONYMS AND ABBREVIATIONS

<b>AMPS</b>	Advanced Mobile Phone System
<b>MS</b>	Mobile Station
<b>BSS</b>	Base Station Subsystem
<b>BST</b>	Base Station Transceiver
<b>BSC</b>	Base Station Centre
<b>MSC</b>	Mobile Switching Centre
<b>PSTN</b>	Public Switched Telephone Network
<b>AMPS</b>	Advanced Mobile Phone System
<b>EV-DO</b>	Evolution-Data Optimized
<b>EDGE</b>	Enhanced Data Rates for GSM Evolution
<b>DECT</b>	Digital Enhanced Cordless Telecommunications
<b>QoS</b>	Quality of Service
<b>IEEE</b>	Institute of Electrical and Electronic Engineers
<b>SSID</b>	Service Set Identifier
<b>QPSK</b>	Quadrature Phase Shift Keying
<b>B3G</b>	Beyond 3G
<b>3GPP</b>	3rd Generation Partnership Project
<b>ETSI</b>	European Telecommunications Standards Institute
<b>ITU</b>	International Telecommunication Union
<b>ADSL</b>	Asymmetric Digital Subscriber Line
<b>DDN</b>	Digital Data Network
<b>CA</b>	Client Authentication

- SMS** Short Message Service
- MMS** Multimedia Message Service
- BSS** Business Support System
- IPCAM** IP Network Camera

<b>FIGURES</b>	
<b>FIGURE 1: A CELLULAR NETWORK MODEL</b>	<b>2</b>
<b>FIGURE 2: THE WORLD'S FIRST WIRELESS TELEPHONE IN COMMERCIAL MARKET</b>	<b>3</b>
<b>FIGURE 3: BASIC STRUCTURE OF THE ORIGINAL GSM CELLULAR NETWORK</b>	<b>5</b>
<b>FIGURE 4: WCDMA NETWORK DIAGRAM</b>	<b>7</b>
<b>FIGURE 5: CDMA2000 WIRELESS NETWORK INFRASTRUCTURE</b>	<b>8</b>
<b>FIGURE 6: NETWORK STRUCTURE OF TD-SCDMA</b>	<b>8</b>
<b>FIGURE 7: WIMAX NETWORK DIAGRAM</b>	<b>9</b>
<b>FIGURE 8: D-LINK WDA-1320 WIRELESS G DESKTOP ADAPTER</b>	<b>12</b>
<b>FIGURE 9: TP-LINK TL-WN322G 54M WIRELESS USB ADAPTER</b>	<b>12</b>
<b>FIGURE 10: CISCO AIRONET 1200</b>	<b>13</b>
<b>FIGURE 11: CISCO AIRONET 1200 WITH ANTENNAS</b>	<b>13</b>
<b>FIGURE 12: ROAMING</b>	<b>14</b>
<b>FIGURE 13: SAMPLE WIRELESS AD HOC NETWORK</b>	<b>15</b>
<b>FIGURE 14: CSA INTEGRATION WITHIN THE CISCO UNIFIED WIRELESS NETWORK ARCHITECTURE</b>	<b>16</b>
<b>FIGURE 15: RELATIONSHIP BETWEEN MOBILITY AND DATA RATE OF WIRELESS TECHNOLOGY</b>	<b>21</b>
<b>FIGURE 16: (A) TIGHT AND (B) LOOSE INTERWORKING ARCHITECTURE OF 3G /WLAN NETWORKS</b>	<b>22</b>
<b>FIGURE 17: SYSTEM NETWORK STRUCTURE</b>	<b>29</b>
<b>FIGURE 18: VIDEO SURVEILLANCE ON PC CLIENT SOFTWARE</b>	<b>31</b>
<b>FIGURE 19: VIDEO SURVEILLANCE ON 3G CLIENT SOFTWARE</b>	<b>32</b>
<b>FIGURE 20: PING 58.249.57.141</b>	<b>38</b>
<b>FIGURE 21: PING 58.248.37.17</b>	<b>39</b>
<b>FIGURE 22: PING 58.248.37.16</b>	<b>39</b>
<b>FIGURE 23: PING 116.21.75.17</b>	<b>40</b>
<b>FIGURE 24: PING 202.108.22.142</b>	<b>40</b>
<b>FIGURE 25: PING 124.40.42.56</b>	<b>41</b>

**TABLES**

<b>TABLE 1: MOBILE TELEPHONE NETWORK SPECIFICATIONS</b>	<b>10</b>
<b>TABLE 2: COMPARISON OF 802.11 WG STANDARDS</b>	<b>11</b>
<b>TABLE 3: SPECIFICATIONS OF 3G AND WAN</b>	<b>20</b>
<b>TABLE 4: IP ADDRESS OF IPCAMS</b>	<b>31</b>



# 1 INTRODUCTION

Nowadays, high-mobility Mobile Telephone Network (MTN) and high-bandwidth Wireless Local Area Network (WLAN) are the most popular wireless technologies. However, deploying either MTN or WLAN cannot meet the demands of access to broadband IP network ubiquitously. This phenomenon forces us to consider integrating MTN networks with WLAN together. Some sophisticated telecommunication operators hastened to merge these two networks together and deploy their cutting edges such as mobile phone that works on Wi-Fi [1]. However, from the author's opinion, the technology of integrating these two networks can be applied to use in broader fields, such as online conferences, online diagnosis, video surveillance and so on.

This thesis aims to find out that why these two heterogeneous networks should be integrated and that how to integrate them together. In other words, we will focus on the design considerations of implementing MWLAN which is the integration of the two hybrid networks. Specially, an actual case -- "God's Eyes" Video Surveillance System -- from a project of author's own experience in his internship is introduced as an example of implementing MWLAN.

After a brief introduction to this thesis, Chapter 2 introduces the evolution and technologies development of mobile telephone network, longitudinally compares telecommunication technologies among different generations. Chapter 3 describes the fundamental knowledge of Wireless Local Area Network, and introduces different types of wireless technologies. Chapter 4 then gives the latitudinal comparison between mobile telephone network and wireless network and introduces the design considerations of implementing MWLAN. Chapter 5 describes an actual case of mobile wireless local area network, and introduces the technical details of building up a video camera surveillance system over mobile wireless local area network.

Summary and outlook to this thesis comes in the end chapter, and details of some technical documents and technology concepts will be described in Appendix.

## 2 OVERVIEW OF MOBILE TELEPHONE NETWORK

The Mobile Telephone Network that we are using every day is in fact the Cellular Network owned by the telecommunication operators. What is the cellular network? In a short word, it is the radiophone service network which consists of hundreds of “cells”. Each cell which is set up with a base station is actually a hexagonal sub-area of the cellular network. This cellular network structure looks like the shape of a "honeycomb" (see Figure 1), and thus the mobile telephone network is called the cellular network.

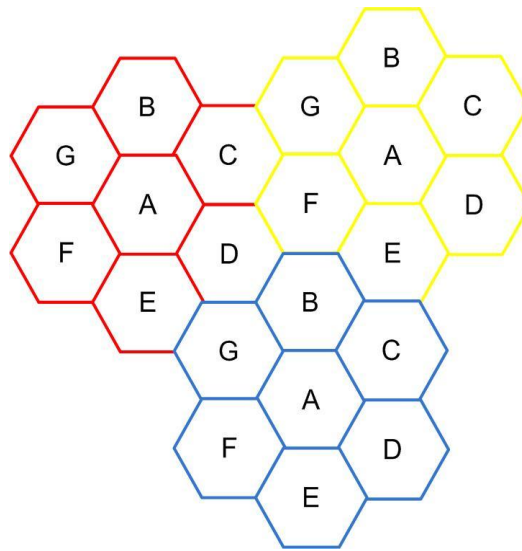

Figure 1: A cellular network model

Cellular networks are widely used because of a mathematical conjecture—the regular hexagon is considered to be the graphic which covers the largest area while using the least nodes. For the purpose of saving the cost of equipments in construction, the regular-hexagon-based network is the optimum utilization of network coverage.

Using frequency multiplexing technology, cellular network became a telecommunication model for all generations. Because each cell uses a set of cellular frequencies, this set of frequencies will not be used by any other adjacent cells. As Figure 1 shows, seven cells are for one group; each cell (from A to G) of one group uses different frequency, but the adjacent group can use these frequencies back. This kind of design make

cellular system has larger capacity than the MTS system and accommodates more users, while making mobile telephone network available as a commercial service.

## 2.1 Analog Cellular System

The first generation of mobile telecommunication technology (1G) is based on radio analog technology of the analog cellular system. The analog cellular system was once the advanced technology (such as AMPS) that enables ordinary people to use wireless telephone (see Figure 2).



**Figure 2: The world's first wireless telephone in commercial market [2]**

*“The analog cellular system was a successful model in wireless communication and led to the digital cellular systems with several evolutions from FDMA to TDMA and to CDMA as of today. There are many clever techniques that have been implemented in the analog system. In the analog system, the signaling channels are only used for call establishing. After the call is connected, the traffic channel handles both voice and signaling by using the property of Manchester code. The use of SAT (Supervisory Audio Tone) for on-hook and off-hook as well as the identification of cells is also clever; of course, the invention of handoffs, used while at a weak-signal condition (at cell boundary), is another great contribution [3].”*

However, as number of analog cell phone users was growing, the analog cellular system could not feed the expanding needs of mobile communication from the mobile phone users, and its technical shortages appeared:

- Low voice quality and security

- Limited performance and radio coverage range
- Lacks of end-user products

To overcome these obstacles, the digital cellular system was deployed to take over.

## **2.2 Digital Cellular System**

The second generation of mobile telecommunication technology (2G) is based on digital cellular technology. As the core technology of 2G, the digital voice transmission technology is different from 1G using analog voice transport technology. The development of technologies such as GSM and CDMA advantages the digital cellular system to break through the limitations of the analog cellular system. By transmitting the digital signals effectively and consuming less radio power, the bandwidth of digital cellular system extraordinarily increases. So forth, the voice quality was improved and the telephone service was no longer limited to voice service but also data or even multimedia service.

Using TDMA and CDMA digital modulation and an independent channel to send signal, 2G improves the capacity and performance of the system. GSM standard and CDMAOne standard are representatives of these two digital modulation technologies.

### **2.2.1 GSM**

Global System for Mobile Communication (GSM) is a 2G standard which is most widely used in the world. Advanced technology such as digital detection, Automatic Retransmission Query (ARQ) techniques and even the OSI Model is introduced to GSM, which improves voice quality, data quality, picture/vision quality (after GPRS is developed in digital cellular system) and service quality [3].

Figure 3 illustrates the basic structure of the original GSM cellular network.

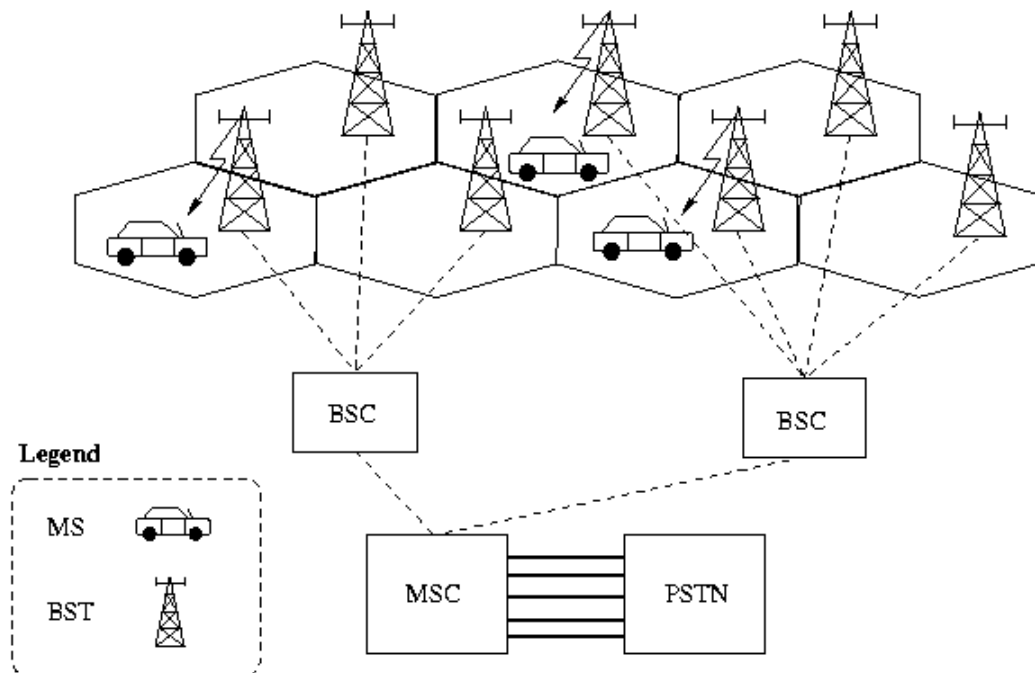

Figure 3: basic structure of the original GSM cellular network [3]

This GSM Cellular network is composed of three main parts:

- Mobile Station (MS)
- Base Station Subsystem (BSS)
- *Switching Subsystem (SS)*

Mobile Stations are the network terminal equipments, such as cellular phone or car phones. Base Station Subsystem includes Base Station Transceiver (BST) and Base Station Controller (BSC). The Mobile Switching Centre (MSC) which connects to the Public Switched Telephone Network (PSTN) is a main element within the switching subsystem (aka core network) area of the mobile telephone network [5].

### 2.2.2 CDMA

Code Division Multiple Access (CDMA) is a branch of digital technology, developed over spread spectrum technology. It is designed for large capacity, high-quality, integrated services, soft switching, and international roaming.

CDMA is a catalyst of the next generation telecommunication technology, as WCDMA, CDMA2000 and TD-SCDMA inherited code division multiple access technology. Because using code division to distinguish user signals, CDMA uses spread spectrum technology to increase bandwidth for achieving multiple access.

### 2.2.3 GPRS

General Packet Radio Service (GPRS) is a telecommunication service based on packet switching technology. GPRS is GSM based technology because they use the same frequency band, bandwidth, burst structure, wireless modulation standard, frequency hopping rules and the same TDMA frame structure. GPRS rises up data rate from 56 Kbps to 114Kbps, providing continuous connection to IP network for cell phone and computer users, featuring advantages of relative high speed and always-online.

## 2.3 The 3G

exponential growth of data traffic has spread from the fixed network to a wireless network, which also includes the mobile telephone network. GPRS -based low data rate 2G network cannot accommodate such high-bandwidth applications as online-movie, online video surveillance etc. To ease the bottleneck in the growth of mobile network service, the third generation of mobile telecommunication technology (3G) appeared on the scene. Currently there are four standards of 3G network: WCDMA, CDMA2000, TD-SCDMA and WiMax.

### 2. 3.1 WCDMA

Wideband Code Division Multiple Access (WCDMA) is a technical specification based on development of the GSM network. For this reason, WCDMA is backward compatible to GSM/GPRS network.

The core network (see Figure 4) of WCDMA can be logically divided into circuit switched network and packet switched network, with responsible for circuit switching business (voice service) and packet switching business (broadband multimedia service).

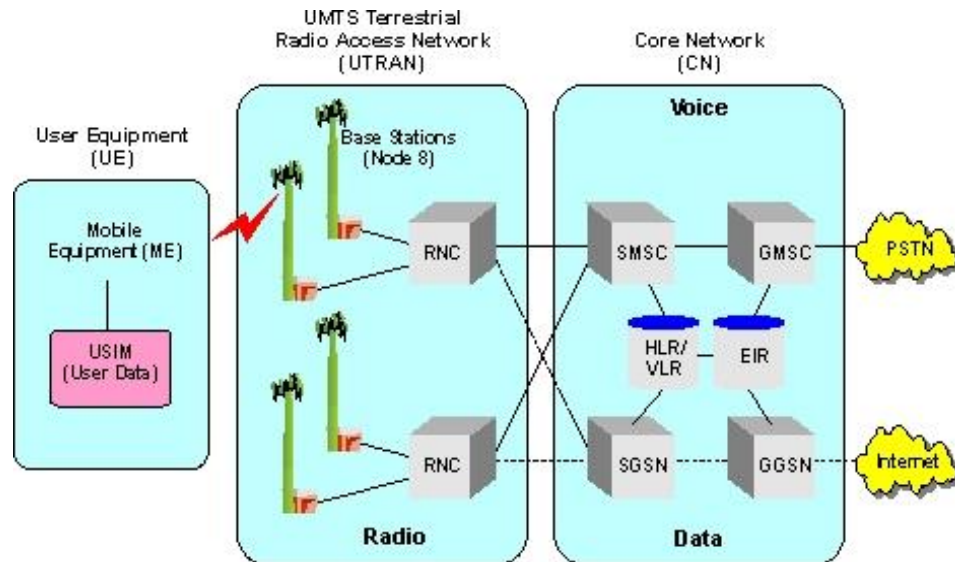

Figure 4: WCDMA Network Diagram [6]

By changing the spread spectrum (for data rate of services lower than 128kbit/s) and multi-code parallel transmission (for data rate of services higher than 128kbit/s), WCDMA can flexibly provide multi-data-rate transmission services and multimedia services.

### 2. 3.2 CDMA 2000

CDMA2000 is the broadband version of the narrowband CDMAOne. Its packet domain is based on the mobile IP technology of the packet switched network. Radio Access Network provides rich interfaces of adaptation layer over the ATM switches based platform. The downlink signals generated by the Base Transceiver Station (aka Base Station, see figure 5) are orthogonal to each other [7]. The Channels of these downlink signals use interference detection to improve the system capacity.

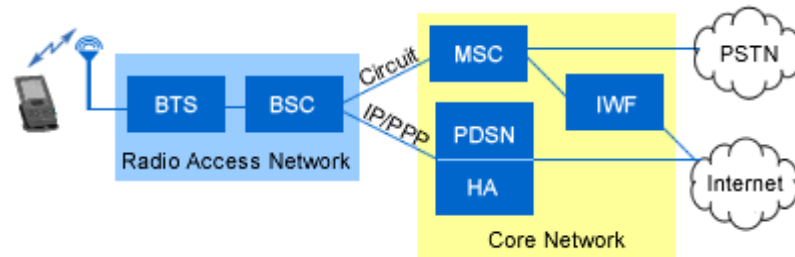

Figure 5: CDMA2000 wireless network infrastructure [8]

### 2. 3.3 TD-SCDMA

Time Division Synchronous Code Division Multiple Access (TD-SCDMA) integrates the industry's leading mature technologies including TDMA, FDMA and CDMA keeping the compatibility with GSM/GPRS network and enabling direct upgrade from 2G to 3G. Key technologies of TD-SCDMA comprises intelligent antenna, joint detection, Multi-timeslot CDMA, DS-SS-CDMA, synchronous CDMA, software radio, Low Chip Rate (LCR), changeable spreading system, adaptive power control, etc [9]. From the Figure 6, we can examine that the network structure is similar to TDMA-based and CDMA-based network.

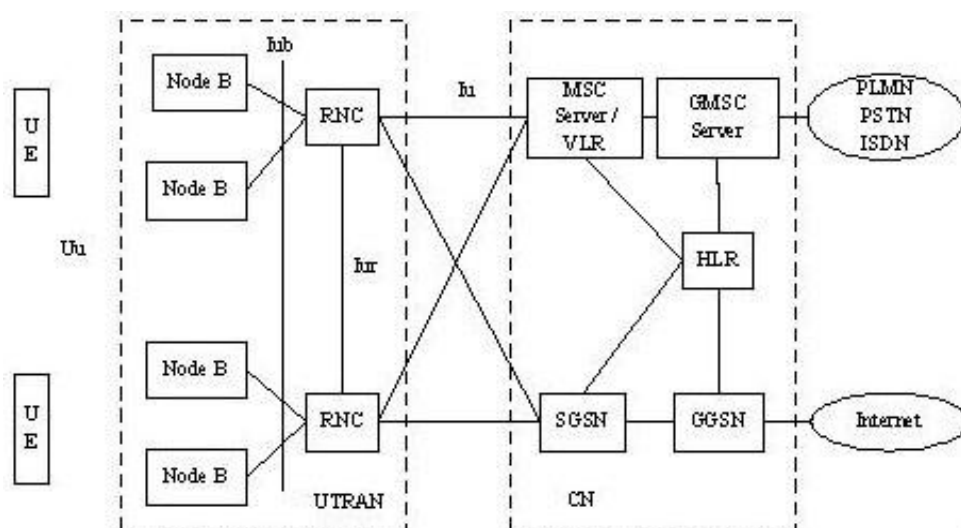

Figure 6: Network structure of TD-SCDMA [10]



### 2. 3.4 WiMax

Worldwide Interoperability for Microwave Access, also goes by the name of IEEE 802.16, is a high speed broadband technology with extensive wireless coverage. Although ITU approved WiMax as a standard of 3G, the industry consider WiMax together with WLAN as Beyond 3G (B3G) system because there is no traditional voice service in WiMax as we can see from its network diagram (Figure 7).

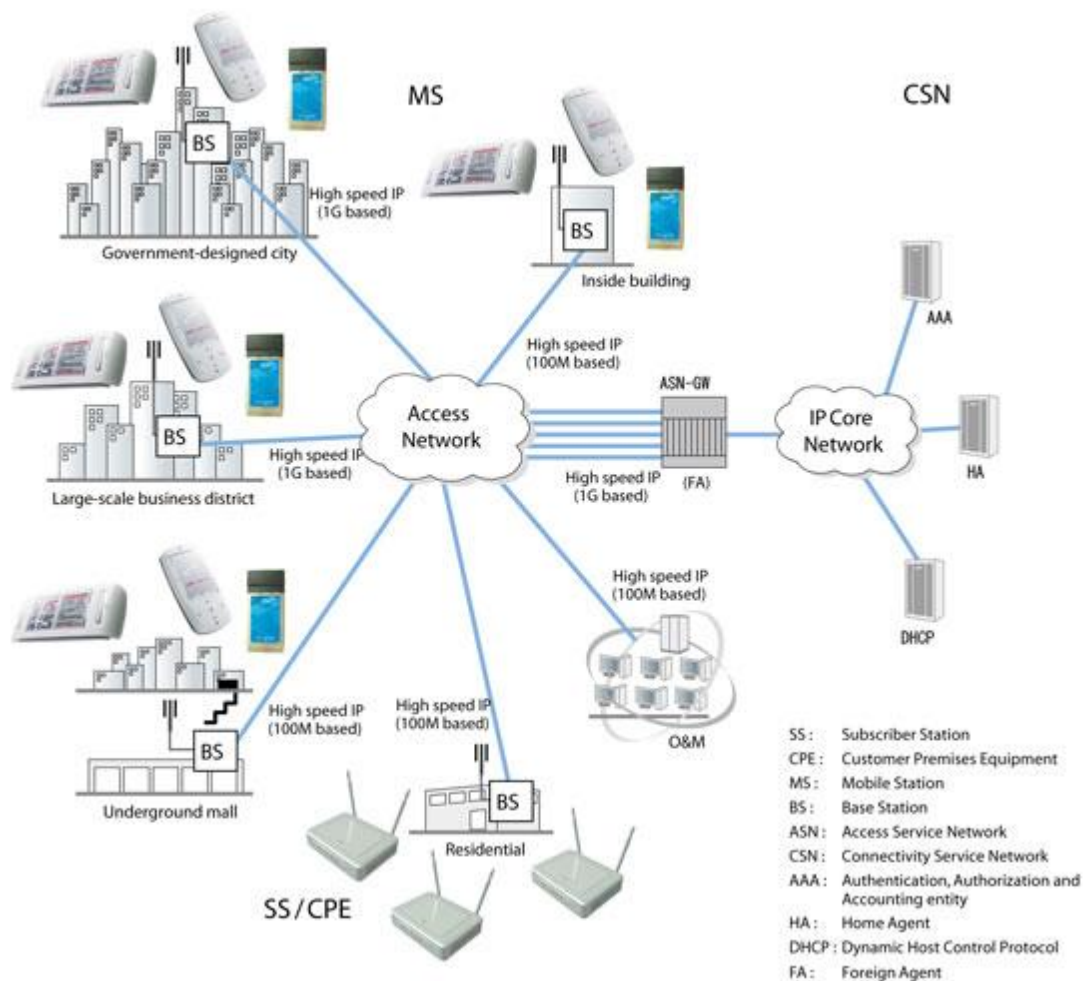

Figure7: WiMax network diagram [11]

As we can see from the diagram, packet data can be sent from mobile station to access network, then to IP core network. Voice data used to be sent through circuit switched network doesn't appear here. Instead of using traditional voice service, WiMax enables Voice over Internet Protocol (VoIP) technology, but users still need GSM network to travel out of the WiMax coverage area.

From Table 1 of mobile telephone network specifications, it is clear that the trend of mobile telephone network is becoming All-IP network, which provides high system capacity and data rates with services of high mobility and broadband access to IP network.

**Table 1: Mobile telephone network specifications**

<b>Generation</b>	<b>Mobile Technology / Switching Method</b>	<b>Sample Deployed System</b>	<b>Data rate</b>	<b>Services Offered</b>
<b>1G</b>	Analog Cellar / Circuit Switched	AMPS	9.6 Kbps	Voice
<b>2G</b>	Digital Cellular / Circuit Switched and Packet Switched	GSM, cdmaOne, GPRS, EDGE	144 Kbps	Voice, SMS, Packet Data
<b>3G</b>	Digital Cellular / Circuit Switched and Packet Switched	WCDMA, CDMA200, TD-SCDMA	14 Mbps	Voice, Multimedia

### 3 OVERVIEW OF WIRELESS LOCAL AREA NETWORK

The demands for wireless connections in high data rates are increasing rapidly [7]. Thanks to this, Wireless Local Area Network (WLAN) technology develops diversely and fast. As mentioned before, cellular network has more coverage and mobility than WLAN. However, the core marketing value of WLAN is that WLAN technology is suitable for high-density demand and higher throughput and speed than cellular network [12]. WLAN and cellular network, each has their merits. WLAN should be integrated with mobile telephone network as a supplement technology of MWLAN. Through introducing following technical details of WLAN, this view will be further amplified.

#### 3.1 IEEE Standards

The common wireless network standard between manufacturer and network user is as important as the common currency money between seller and buyer. You cannot use a 802.11a device in 802.11b network as you cannot use euros in China. What's worse, there was even no 802.11a/b standard to be referred when choosing between the network types and the device types until the IEEE's standards for WLAN. These standards are known as the members of the IEEE 802.11 Working Group (WG) today, and Wi-Fi is its trademark in commercial market.

**Table 2: Comparison of 802.11 WG standards**

Standard	802.11a	802.11b	802.11g	802.11n
Frequency bands	5 GHz	2.4 GHz	2.4 GHz	2.4/5 GHz
Data rate	54 Mbps	11 Mbps	54 Mbps	150 Mbps
Modulation Type	64QAM	DQPSK	OFDM	OFDM

As shown in table 2, the maximum data rate of WLAN is up to 150Mbit/s of 802.11n, which is far more than 3G's (excluding B3G's) data speed. As the supplement technology of MWLAN, the 802.11a/b/g standards are the most popular deployed wireless standards. Various kinds of wireless terminal devices are available in the market for different users. Building up WLANs and developing applications on top of wireless network is becoming relatively easy and cost-effective for both individuals and companies.

### 3.2 Network Architecture

A wireless network includes at least two nodes which are two devices with WLAN adapter. Figure 8 shows an embedded WLAN adapter. Figure 9 shows a plugin USB wireless adapter. These two nodes can be both desktop workstation and notebook computer. As long as they are equipped with wireless adapters, they are peers of this private peer-to-peer network. In this network environment, each device can be the server or client, but the throughput and the security of this network connection are relatively low. Another technical defect is that WLAN adapters from different manufacturers are often incompatible with each other.



Figure 8: D-Link WDA-1320 Wireless G Desktop Adapter [13]



Figure 9: TP-Link TL-WN322G 54M Wireless USB Adapter [14]

A wireless Access Point (AP), as shown in Figure 10, connects to wired LAN through landline, providing connectivity to wired LAN and access to Internet. AP is attached with antennas (see Figure 11) which are used for receiving and transmitting radio signals. These radio signals will cover a range of area, and this particular area is called cell. This cell of WLAN acts similarly as the cell of mobile telephone network mentioned before, but it is composited by APs instead of base stations.



Figure 10: Cisco Aironet 1200 [15]

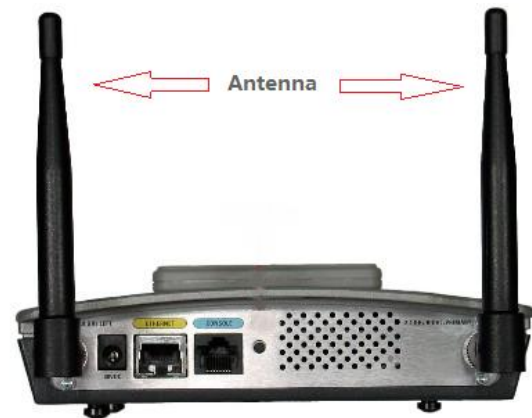

Figure 11: Cisco Aironet 1200 with antennas [15]

Usually, the size of the cell can range from 91.4 to 152.4 meters, depending on the size and *gain* of the AP, and the geographical condition and architectural construction of the location where the AP is installed [16]. A huge wireless network formed by APs supports roaming which is similar to the services in mobile telephone network. Each of these AP can be established within a certain coverage range of their respective WLAN. Wireless devices (such as notebook, netbook, and cell-phone with Wi-Fi) can enjoy seamless roaming through these overlapping WLANs (see Figure 12).

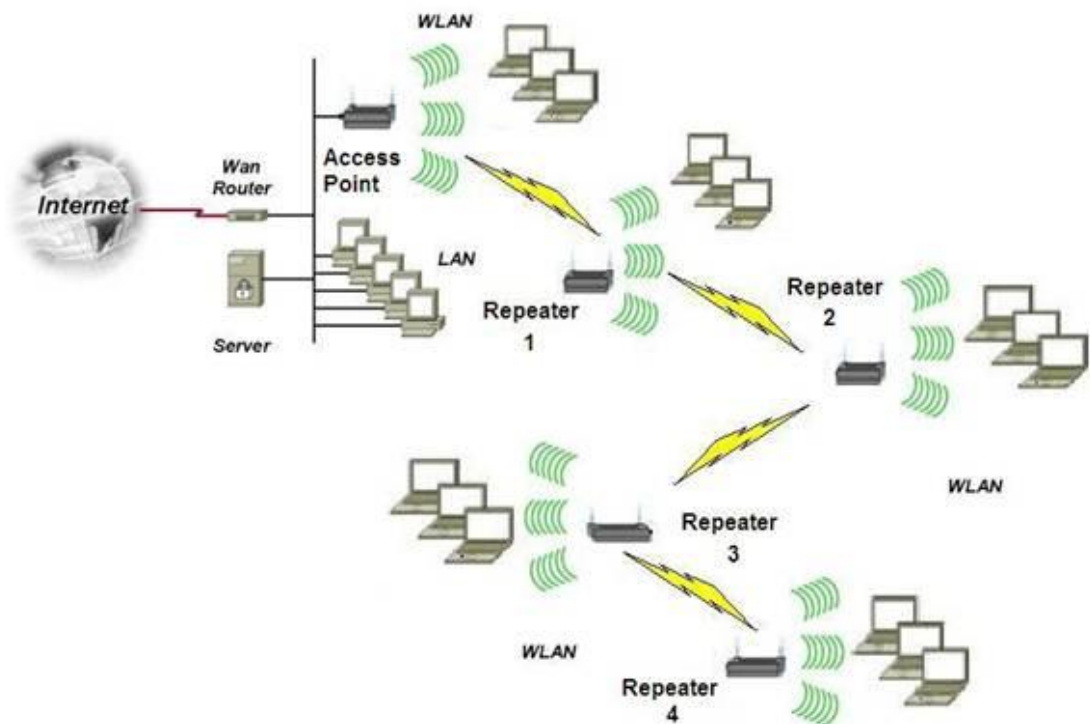

Figure 12: Roaming [17]

It is worth noting, however, WLAN overlapping rate of seamlessly roaming will play a key role. Also because of this overlapping rate issue, the coverage of the wireless network is outmatched by the mobile telephone network's coverage. The next chapter will examine this issue in detail.

## Types of WLAN

In general, there are two types of WLAN: peer-to-peer network and infrastructure network.

- Peer-to-peer network: consists of a group of computers which equipped with wireless network adapters. These computers are directly connected to each other within the same workgroup name, SSID and WEP, and they are able to communicate with each other without needing a central AP. The *Ad Hoc Network* (Figure 13) is a typical type of peer-to-peer network.

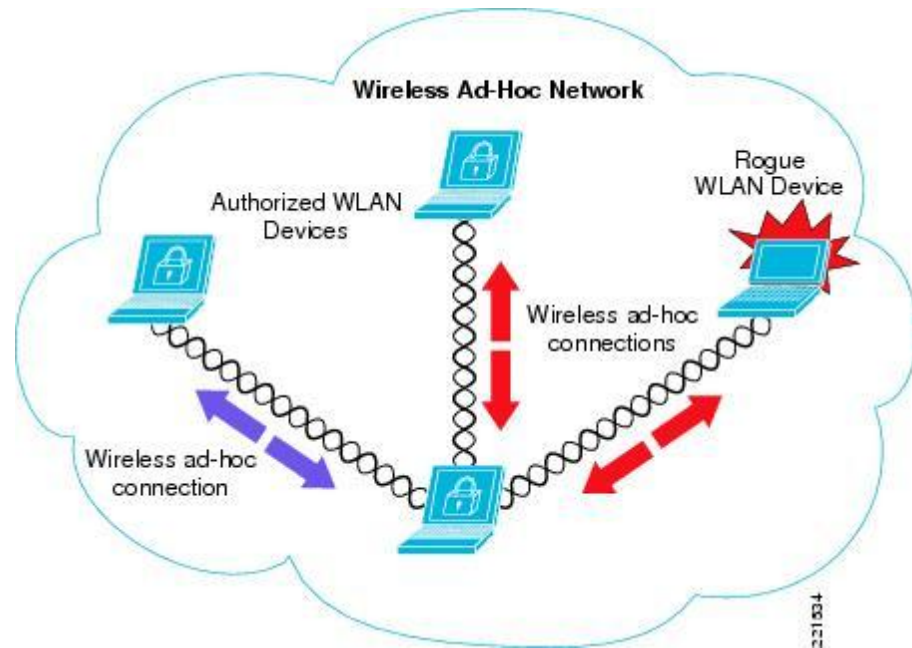

Figure 13: Sample Wireless Ad Hoc Network [18]

- Infrastructure network: the connectivity between wireless devices and the diverse and complex WLAN is established among wireless bridges, wireless gateways, wireless access controllers, and wireless access servers, basing on an AP as the central hub of the network. Infrastructure network is the mostly deployed WLAN topology (Figure 14).

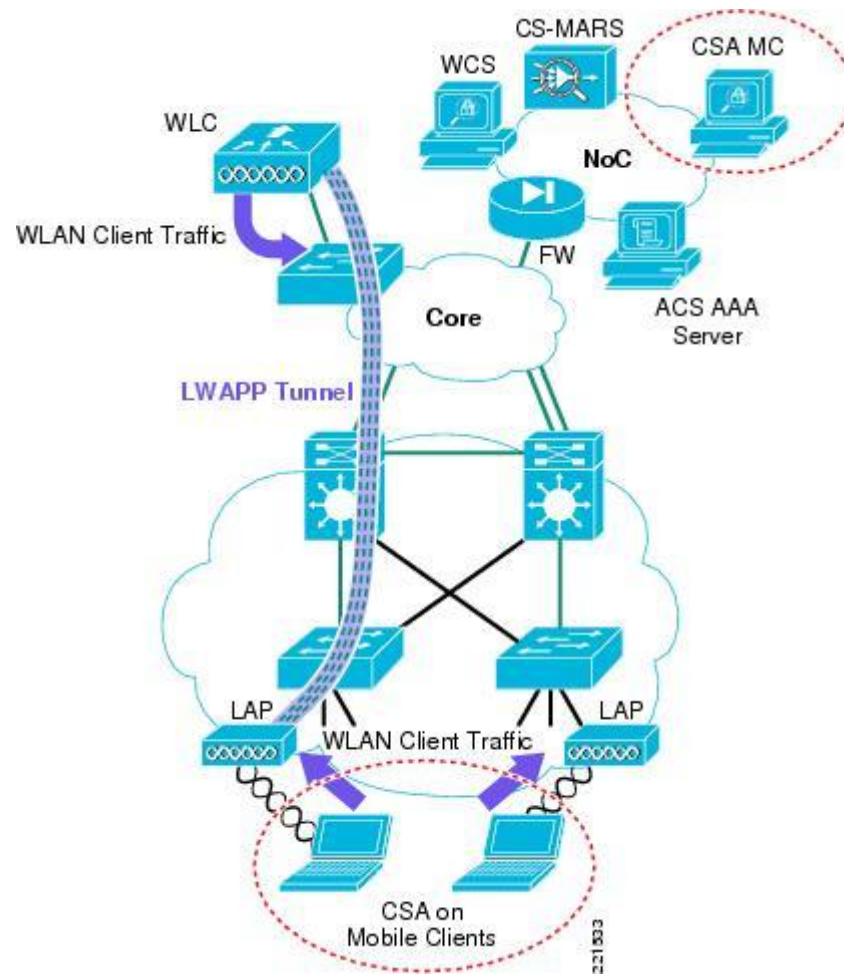

Figure 14: CSA Integration within the Cisco Unified Wireless Network Architecture [18]

### 3.3 WLAN Frame Transmission

Though WLAN shares technologies such as routing and switching with LAN, they belong to different IEEE WG standards. LAN is covered by the IEEE 802.3 WG which also refers to Ethernet. For this reason, WLAN do not pass the 802.3 frame. “Usually the WLAN frame size is limited to 1518 bytes because it is most commonly connected to a wired Ethernet network.” [16]



### 3.4 Authentication and Security

WLAN authentication is the process of authenticating the wireless device. There are two methods of authentication:

- Open system: This process is an open connectivity standard in which only the SSID must match [16]. For open system authentication to work both wireless device and wireless Access Point must have exactly the same SSID.
- Share key: An encryption method is required in this process. Besides SSID, user needs to share the same encryption key as configured in the wireless AP.

Non-secure WLANs can expose network traffic and resources to unauthorized users. Such individuals can use ARP spoofing to exploit network resources and capture others' privacy such as online-chatting records, email information and even bank account information. So, security is a principal consideration for implementing a WLAN network. Understanding the encryption types below helps network structure designer choose the suitable method of securing WLAN.

#### Encryption Types of 802.11 WG [19]

- WEP: Wired Equivalency Privacy, the original security standard for wireless LANs, easily exploited by software that can break the encryption after capturing traffic and recognizing encryption patterns.
- 802.1X: 802.1X is the IEEE standard for wired and wireless LAN access control. It provides a means of authenticating and authorizing devices attached to a LAN. 802.1X defines the Extensible Authentication Protocol (EAP). EAP uses a central authentication server to authenticate each network user. EAP also has some vulnerabilities.
- LEAP: Lightweight Extensible Authentication Protocol (LEAP), developed by Cisco, is based on the 802.1X authentication framework but addresses several weaknesses using dynamic WEP and sophisticated key management. LEAP also adds MAC address authentication.

- PEAP: Protected Extensible Authentication Protocol (PEAP) provides secure transport of authentication data, including passwords and encryption keys. With PEAP, wireless clients can be authenticated without certificates, simplifying the secure wireless LAN architecture.
- WPA: Wi-Fi Protected Access (WPA) is a subset of the 802.11i security standard and is expected to replace WEP. WPA combines Temporal Key Integrity Protocol (TKIP) and 802.1X for dynamic key encryption and mutual authentication.
- TKIP: Temporal Key Integrity Protocol (TKIP) is part of the IEEE 802.11i encryption standard. TKIP provides per-packet key mixing, a message integrity check, and a re-keying mechanism, fixing the flaws of WEP.
- WPA2: WPA2 is second generation WPA, providing Wi-Fi users a high level of assurance that only authorized users can access their wireless networks. WPA2 is based on the final IEEE 802.11i amendment to the 802.11 standard.

## **4 DESIGNING A MOBILE WIRELESS LOCAL AREA NETWORK**

Mobile Wireless Local Area Network (MWLAN), as it can be interpreted from its name, is the combination of two most popular wireless technologies – Mobile Telephone Network (MTN) and Wireless Local Area Network (WLAN). The interworking architectures of these two wireless networks are adopted as the solution of integrating 3G and WLAN by 3G Partnership Project (3GPP). This chapter expounds the complementary relationship between 3G and WLAN, introduces the interworking models and the applications for these two heterogeneous wireless networks and demonstrates rules and approaches for designing MWLAN.

### **4.1 Comparison of 3G and WLAN**

WLAN provides extra channel capacities with radio coverage of 50 meters or 200 meters radius at indoor or outdoor environment by utilizing cell sectorization and multiple-input multiple-output (MIMO) techniques. On the other hand, the main advantage of WLAN is the low cost deployment: the total cost of deploying a large number of APs is still smaller than the cost of deploying a 3G network [14].

As shown in Table 3, 3G network provides wider area coverage which WLAN can't. 3G works at 2.1 GHz licensed frequency band whilst WLAN works at 2.4 GHz unlicensed frequency band. Besides, auctions for 3G spectrum licenses bring up the cost of 3G services deployment [20].

Table 3: Specifications of 3G and WLAN

Technology	3G (WCDMA)	WLAN (802.11g)
Frequency Band (GHz)	2.1	2.4
Data Rate (Mbps)	14	54
Coverage (m)	200 – 10,000+	50 indoors and 200 outdoors
Modulation Scheme	QPSK	OFDM/DSSS

Both WLAN and 3G can offer broadband and high-speed wireless connections while earlier wireless technologies cannot. Through Table 3, we can see that the data rate of WLAN are almost four times higher than 3G, meaning that WLAN offers more bandwidth, and the OFDM modulation makes WLAN achieve high data rate in a limited area. For these reasons, WLAN is more suitable for broadband wireless access with limited mobility, while 3G is more suitable for low-density demand for wireless connectivity with high mobility.

The main difference between 3G and WLAN is the mobility limitation of their terminal devices. 3G network can be broadly deployed because of its matured techniques of high-speed roaming for mobile stations, while WLAN is restricted by location-dependent availability and limited terminal speed/mobility. As we mentioned, the 3G system of Mobile Telephone Network is more complicated and expensive to implement than WLAN, but its high range coverage guarantees users' uninterrupted connectivity and stable QoS even during high-speed moving. However, comparing to WLAN, 3G's relatively low data rates in some hot-spot area of high-density demands of Internet services can not ensure better QoS, because of the limited capacity of 3G network. Figure 15 reveals the relationship between mobility and data rate of wireless technology. The more data rates WLAN offers, the less mobility it provides.

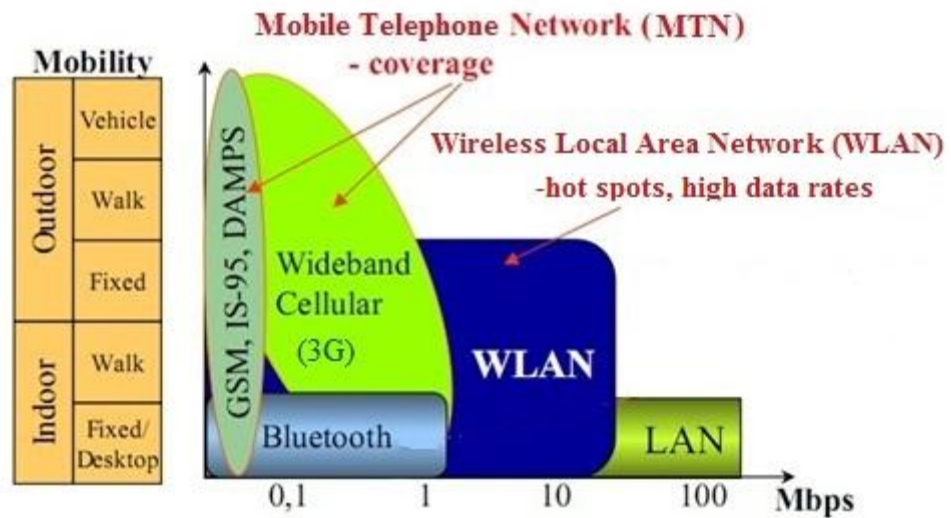

Figure 15: Relationship between mobility and data rate of wireless technology [21]

The above analysis leads to a point that using the advantages of 3G and WLAN can bring out the MWLAN implementation of long coverage, wide bandwidth, high speed and mobility, multi access and cost effective.

## 4. 2 Interworking architectures of MWLAN

There are two different coupling models for integrating MTN and WLAN: loose and tight interworking. The MWLAN interworking architectures have been discussed and standardized by IEEE and ETSI. Therefore, ETSI proposed six scenarios for 3G and WLAN interworking, according to the integration level from shallow to deep, they are: Common Billing and Customer Care, 3GPP system based Access Control and Charging, Access to 3GPP system Packet Switched based services, Service Continuity, Seamless Services and Access to 3GPP Circuit Switched Services [22].

### 4.2.1 Loose Coupling Model

In the loose coupling model (Figure 16 (a)), WLAN is attached to the core network of 3G network as a supplementary technology. WLAN and 3G network remain almost apart except from sharing the AAA server in order to avoid intermixing traffic flows of these

two different access techniques. This interworking model ensures these two networks operate separately and the 802.11 standard of WLAN unchanged. For this reason, implementing loose coupling model is relatively easy while the telecommunication operator just need to focus on deploying WLANs beyond their existed 3G network.

Sharing the AAA framework, the 3G operator can use the unified authentication system in these two heterogeneous networks, collect the user information from WLAN for generating common billing invoice to clients, and ensure roaming service for customers by subscribing agreements with other operators. [23]

#### 4.2.2 Tight Coupling Model

In tight coupling model (Figure 16 (b)), 3G nodes, also referred to base stations, and WLAN are connected to the 3G core network. By this way, the MWLAN takes full advantages of the existed 3G mechanism such as mobility, security and QoS. However, there are two underlying defects of tight coupling model.

Firstly, in order to connect to 3G core network, WLAN devices are required to tailored and customized for supporting both UMTS and CDMA. Secondly, in this interworking model, WLAN brings traffic flows and signals to 3G backbone network. Comparing to WLAN, 3G network is characterized by different transfer model and traffic flows. For this reason, the 3G backbone network is required to be redesigned in mechanism.

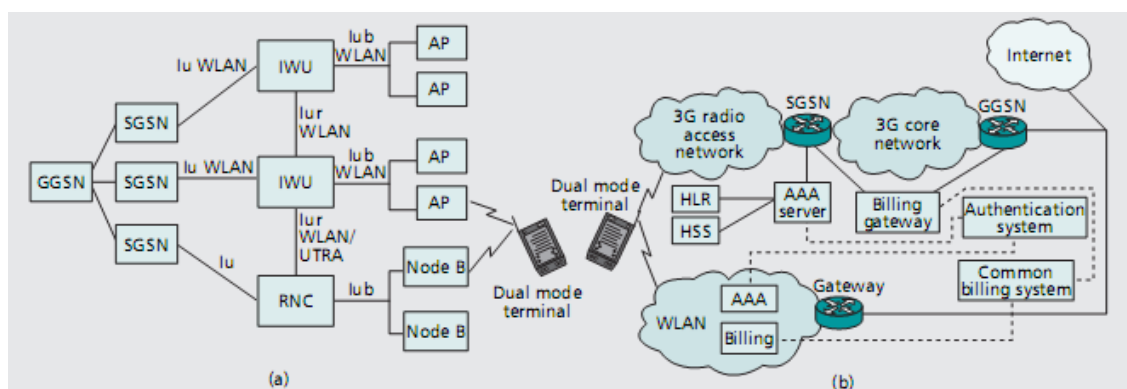

Figure 16: (a) Tight and (b) loose interworking architecture of 3G /WLAN networks [20]

### 4. 3 Rules and Approaches of Designing MWLAN

To implement MWLAN, there should be rules and approaches.

#### 4.3.1 Rules of Designing

- Forward-looking

The network design should be forward-looking by means of using advanced devices and techniques to ensure that the core network architecture and key technology will not be changed with the developing techniques in a period of time, and can be applied to the application of new technologies.

- Practicability

The network design should also consider the actual situation of the project and actual needs of users, so as not to be too ahead of technology caused the waste of investment.

- Reliability

Whether the network architecture is reasonable, whether the selection of network equipments is appropriate and whether the quality of construction is normative etc. will affect the reliability of network operation. Thus, ensuring the network reliability is an important principle of network design. In addition to this, the important equipments are required to have redundancy backups.

- Openness

During the process of designing, one must consider whether the applied technical standards and network protocols are compliance with international norms or industrial standards, which in order to ensure the compatibility and extendibility of under-designed network. For WLAN, one can refer to aforementioned IEEE 802.11 WG; and ITU as 3G.

- Wireless Radiation

Deploying wireless network should follow the legislations of a country. Usually, the terminal uses transmitting power less than 5mW to avoid long-term radiation to human bodies from larger transmitting power.

- Interference

The integration of MWLAN causes uncoordinated interference, which in turn reduces the coverage of wireless access. Interference management should be concerned when designing network.

- Security

wireless network supports various security features such as using centralized authentication and encryption to each packet. In the process of designing network, security issues among radio access layer, core network layer and application layer should be considered.

#### 4.3.2 Approaches of Designing

- Site Survey

When designing MWLAN, we need to conduct the site survey to determine the best placement and coverage, or overlap for transmitter devices. Because wireless signal is propagated linearly in the air, the transmission of radio waves, capability of data receiving and transfer speed is affected by the surrounding objects. We should measure how many obstacles such as walls at indoor area and buildings at open area for eliminating interference.

- Network Structure

Designing network structure should refer to the two aforementioned interworking architectures. After choosing the coupling model, 3G standard, WLAN standard, corresponding terminal devices and protocols should be considered as well.

- Troubleshooting Management

Concerning to the issues such as traffic overload, signal blind area, signal interference and malicious access, we can use automatic RF technique to monitor and spot the surrounding radio signals. Besides, the interoperability issue such as expired-session when switching network between 3G and WLAN must be taken into account and addressed for solutions referring to the six scenarios proposed by ETSI.



- Securing Network

We can secure the MWLAN not only in terms of network structure, hardware devices, security policies and RF detecting, but also cryptographic techniques such as public-key encryption and signing, AAA technologies, and security manager for inspecting and monitoring downloaded code in applications layer. [12]

- Redundancy Configuration

Key hardware such as wireless controller is required to be back up for software and hardware redundancy. Some important APs can be duplicated back up.

- QoS

“IEEE 802.11e defines QoS mechanisms for wireless gear that gives support to bandwidth-sensitive applications such as voice and video [24].” Referred to IEEE 802.11e, we can adjust higher priority for voice and video transfer than normal data transfer when transferring data in MWLAN.

#### **4. 4 Applications of MWLAN**

MWLAN can be widely implemented to public areas such as amusement parks, hotels, airports and railway stations to achieve online surfing; can be used in government office buildings, schools, enterprises and institutions to achieve mobile office, to facilitate meetings and classes; can be used in medical assistance to provide online diagnosis service in a moving ambulance etc.

for the harsh environment such as older buildings, desert areas, etc., for the frequently changing environment such as various exhibition buildings; for the temporary need for broadband access, mobile workstation, the establishment of MWLAN is the ideal choice. MWLAN network can be applied to following industry:

- Sales Industrial Application
- Logistics Applications
- Application of Electric Power Industry

- Application of the Service sector
- Education and Industrial Applications
- Application of the Securities Industry
- Art gallery Application
- Small office / home office applications
- Office applications between the corporate office building

## 5 CASE STUDY

This case is one of the applications of MWLAN which is based on a project of video surveillance system of China Unicom where I served my internship. It introduces a video surveillance system called “God’s Eyes” Video Surveillance System (GEVSS) which works on the MWLAN network. By implementing loose coupling model of MWLAN, both 3G and WLAN are integrated together, thus the defect of traditional low-speed mobile telephone network which limits the performance of GEVSS can be solved. The performance showcase proves the high data rates and low latencies of MWLAN.

### 5. 1 GEVSS over MWLAN

Traditional mobile communication has a fatal flaw – low transfer data rate. Even with the most advanced H.264 video encoding technology, the transfer signal of all the way clear and full frame rate in video surveillance will consume more than 200Kbps throughput. The “God’s Eyes” Video Surveillance System (GEVSS) is a generalized concept of video surveillance business that provides internal management and security features such as remote video monitoring of professional services to consumers. Furthermore, GEVSS is an important part of the broadband system. Through building up a service platform for video surveillance service over broadband IP network including IEEE 802.3, IEEE 802.11, and 3G/B3G, GEVSS provides customers services such as access to platform resources and video surveillance.

GEVSS innovatively combines original landline broadband applications with 3G network applications to support video surveillance through online streaming media to 3G mobile client. By using broadband networks which consist of IEEE 802.3 and IEEE 802.11 and WCDMA network from China Unicom, decentralized and independent image-collecting points can access to Internet through ADSL, DDN, WLAN or 3G, so that GEVSS can provide client with unified control, storage and management in cross regions and create a new, visualized and vision-expanded and audition-expanded management tool.

## 5. 2 Project Plan

loose interworking model of MWLAN is chosen for this project because it requires a few changes to the existed 3G network and wired network of China Unicom, and it is a fast and cheap deployment which meets customer's requirements in this case. China Unicom has widely deployed WCDMA standard for 3G network. Thus implementing MWLAN requires building WLAN infrastructures which should be compatible with the WCDMA network in this circumstance. For these reasons, the project of "GEVSS over MWLAN" mainly focuses on WLAN implementation plan.

Before deploying MWLAN, there are three phases for this plan:

- Location site survey phase

In this phase, we first implement RF site survey by using such site survey tools as Cisco Aironet NIC, Symbol Spectrum24 or Agere Orinoco. Then we need to determine the coverage area and number of APs. The optimization of implementing MWLAN should be not only considered in terms of coverage, but also the capability of load balancing to guarantee QoS. Furthermore, wireless signal overlapping is very important because it guarantees the utilization of roaming.

- Planning wireless nodes phase

Positioning APs should follow the principles: the coverage areas of APs are seamless and the overlapped coverage areas are the smallest among coverage areas. The first principle ensures every single corner is under covered while the second principle minimizes the number of deployed APs.

Planning wireless nodes phase includes selecting WLAN standards and channels. Using 802.11a is suitable for transferring and sharing data in conference room; using 802.11b satisfies the demands of checking emails and browsing web pages in lounges; using 802.11g is the best choice for SOHO business. The wireless signal has to work on different channels to reduce interference. We can use frequency multiplexing technology as MTN for WLAN.

- Selecting wireless devices phase

It is no doubt that the larger coverage the AP has, the better mobility service it offers. However, larger coverage requires larger power from the wireless device. Too large

radio power is bad for health. selecting wireless devices should consider whether they are harmful to people and whether the transfer data rates of them are stable. Furthermore, the security features of devices are most important. Good quality wireless devices provide not only the common encryption services such as WEP, but also IP routing features such as IP filtering or VPN. Some of them are equipped with Stateful Packet Inspection (SPI) techniques to protect Denial of Service (DoS) attack.

### 5.3 System Network Structure

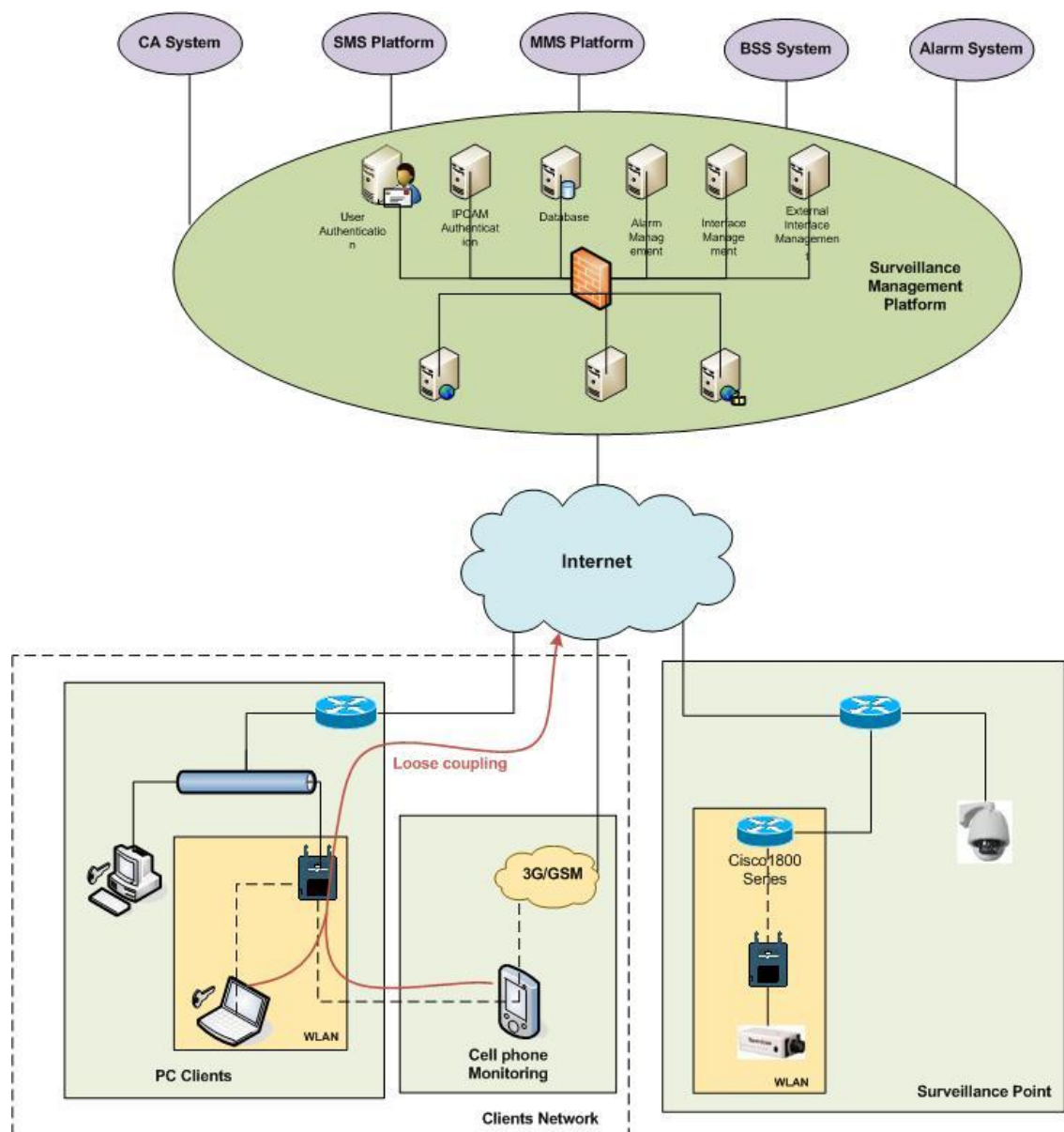

Figure 17: System network structure

As shown in Figure 17, the GEVSS is mainly composed of three parts: Surveillance Management Platform, Surveillance Point and Client Network. In this case study, the Client Network of GEVSS is based on the loose coupling model of MWLAN. A client carrying a 3G/Wi-Fi dual mode device can get access to Internet through 3G network or WLAN. In this scenario, an outdoor mobile phone client wants to achieve real-time monitoring from the Surveillance Point. The request information from the cell phone reaches the Surveillance Management Platform through internet. After authentication, the cell phone client achieves the video stream from the IPCAM.

#### **5. 4 Performance Showcase**

The table 4 shows the IP address of four cameras installed in different geographical locations and the additional IP address from two internet websites are used for comparison. The time delays for each address are shown by Figure 20 – figure 25 in Appendix. The video stream with a speed of 25 frames per second can be played online fluently under an average time delay of 4 seconds. From the Ping results of Figure 5.61 – figure 5.66, we can find out that the every round-trip time for test packets sent form a local host are within the permissible 4 seconds, meaning that GEVSS works over MWLAN smoothly.

Table 4: IP Address of IPCAMs

IPCAM IP Address	IPCAM Physical Address	Memo
58.249.57.141	confidential	Port: 881
58.248.37.17	confidential	Port:80
58.248.37.16	confidential	Port:80
116.21.75.17	confidential	Port:884
202.108.22.142 (external testing address)	/	Port:80
124.40.42.56 (external testing address)	/	Port:80

Video surveillance on PC client software



Figure 18: Video surveillance on PC client software

### Video surveillance on 3G client software:



Figure 19: Video surveillance on 3G client software



## 6 Summary

In this thesis we firstly discussed the technologies and architectures of the Mobile Telephone Network and Wireless Local Area Network. For MTN, we found that 3G network can be broadly deployed because of its matured techniques of high-speed roaming for mobile stations, but it is less competitive than WLAN for implementing especially in the area with a great number of users. For WLAN, it is relatively more applicable than MTN to provide broadband access for high-density users' area, but it is restricted by location-dependent availability and limited wireless device speed/mobility.

Secondly, we analyze the relative technical specifications between MTN and WLAN through comparing frequency bands, data rates, coverage areas and modulation schemes. All the attributes from these two networks lead to the conclusion that they have complementary advantages and disadvantages. This is the reason for integrating and developing MTN and WLAN into MWLAN.

After comparing these two networks, the interworking architectures, the rules and methods of designing MWLAN are discussed for how to implement MWLAN. Furthermore, we addressed the industry fields where MWLAN can be applied to.

In the end, a case study shows the deployment of MWLAN in the field of video surveillance. The testing results from the performance showcase prove that the design considerations of implementing MWLAN are feasible. My thesis work is done till here, but the work of implementing MWLAN are expected to be continued by exploring the possibilities of applying MWLAN in different fields.

## Reference

- [1] [www-document]. T-Mobile @Home - General Information,  
<http://support.t-mobile.com/doc/tm23449.xml> (Accessed 18 June 2010)
- [2] [www-document]. Available at:  
<http://www.motorola.com/staticfiles/Business/Corporate/US-EN/history/feature-cell-phone-development.html> (Accessed 18 June 2010)
- [3] Lee, William C. Y., Wireless and Cellular Telecommunications, New York, NY, USA: McGraw-Hill, 2005. p 26,59
- [4] Lourens O. Walters & P. S. Kritzinger, 2000, ACM New York, NY, USA, Volume 7 , Issue 2
- [5] [www-document]. GSM Network Architecture,  
[http://www.radio-electronics.com/info/cellulartelecomms/gsm\\_technical/gsm\\_architecture.php](http://www.radio-electronics.com/info/cellulartelecomms/gsm_technical/gsm_architecture.php) (Accessed 18 June 2010)
- [6] [www-document]. Available at:  
[http://www.wirelessdictionary.com/wireless\\_dictionary\\_WCDMA\\_definition.html](http://www.wirelessdictionary.com/wireless_dictionary_WCDMA_definition.html)  
(Accessed 18 June 2010)
- [7] Andreas F.Molisch, Wireless Communications, John Wiley & Sons, Ltd., 2009, p 500,541
- [8] [www-document]. Available at:  
<http://www.altera.com/end-markets/wireless/cellular/cdma2000/wir-3gcdma2000.html>  
(Accessed 18 June 2010)
- [9] WCDMA, Wireless Network Design and Optimize, Posts & Telecom Press, 2007, p 5
- [10] [www-document]. Available at:  
<http://www.funocn.com/englishsite/ShowWireless.asp?menuNum=3> (Accessed 18 June 2010)

- [11] [www-document]. Available at: <http://cpe.kmutt.ac.th/wiki/index.php/WiMax2>  
(Accessed 18 June 2010)
- [12] Minoru Etoh, Next Generation Mobile Systems: 3G and Beyond, John Wiley & Sons, Ltd., 2005, p 94, 283-284
- [13] [www-document]. Available at: <http://www.dlink.com/products/?pid=WDA-1320>  
(Accessed 18 June 2010)
- [14] [www-document]. Available at:  
<http://www.wireless-driver.com/download/tplink/tp-link-tl-wn322g-54m-wireless-usb-adapter-drivers-download.htm> (Accessed 18 June 2010)
- [15] [www-document]. Available at: <http://www.cisco.com> (Accessed 18 June 2010)
- [16] Cisco Networking Academy Program CCNA 1 and 2 Companion Guide, Third Edition, Cisco Press, 2003, p164,166,167
- [17] [www-document]. Available at: <http://www.ccareuae.com/Wireless.html>  
(Accessed 18 June 2010)
- [18] [www-document]. 802.11 Basics,  
[www.bb-elec.com/bb-elec/literature/tech/wireless\\_basics.pdf](http://www.bb-elec.com/bb-elec/literature/tech/wireless_basics.pdf), p3 (Accessed 18 June 2010)
- [19] [www-document]. Available at:  
[http://www.cisco.com/en/US/docs/solutions/Enterprise/Mobility/secwlandg20/ch7\\_2\\_SPMb.html](http://www.cisco.com/en/US/docs/solutions/Enterprise/Mobility/secwlandg20/ch7_2_SPMb.html) (Accessed 18 June 2010)
- [20] IEEE Wireless Communications 536-1284, Services in Interworking 3G and WLAN Environments, IEEE, October 2004
- [21] [www-document]. Wireless-LAN: a Complement to 3G for Wireless Access,  
[http://www.nordunet2002.dk/powerpoint/a\\_\\_christian\\_bergljung.pdf](http://www.nordunet2002.dk/powerpoint/a__christian_bergljung.pdf), p3 (Accessed 18 June 2010)
- [22] ETSI TR 122 934 V9.0.0 (2010-01), "Interworking scenarios", p15
- [23] Korhonen, Juha. *Introduction to 3G Mobile Communications (Second Edition)*. Norwood, MA, USA: Artech House, Incorporated, 2003. p464

- [24] [www-document]. Available at: <http://www.networkworld.com/details/6224.html>  
(Accessed 18 June 2010)
- [25] [www-document]. Available at:  
<http://www.networkworld.com/newsletters/wireless/2010/032210wireless2.html>  
(Accessed 18 June 2010)
- [26] [www-document].  
[http://www.garethjmsaunders.co.uk/pc/net\\_wfwg\\_01\\_hardware.html](http://www.garethjmsaunders.co.uk/pc/net_wfwg_01_hardware.html), Thursday 13  
May 2010 (Accessed 18 June 2010)

## Appendix

### ***Switching Subsystem***

It is the core network of GSM, consist of home location register, visitor location register and mobile services switching center.

### ***Manchester code***

The Manchester code, also known as Phase Encoding, is an encoding method which synchronously encodes the clock rate and data of the "01" bit stream.

### ***Hub***

A hub is the most simple central connection device. It is simply a device that provides a connection between the ports that allows the computers plugged into it to talk to one another. Hubs typically provide from 4 to 24 connections, allowing anything from 2 to 24 devices to communicate with one another [25].

### ***Switches***

Switches are a little more complicated than your simple hub. All you need to know is that They handle the connections between devices a little better than hubs, as each port is assigned its own dedicated bandwidth. If that last part didn't mean anything to you do not worry: if you have the choice between a hub and a switch and can afford it, I would always choose a switch [25].

## Gain

Gain measures respectively the ratio of output current, voltage, or power to input current, voltage, or power. Gain is usually expressed in dB. If the ratio is less than one, negative in dB scale, there is a loss between input and output [26].

## Testing result from different IPCAM addresses

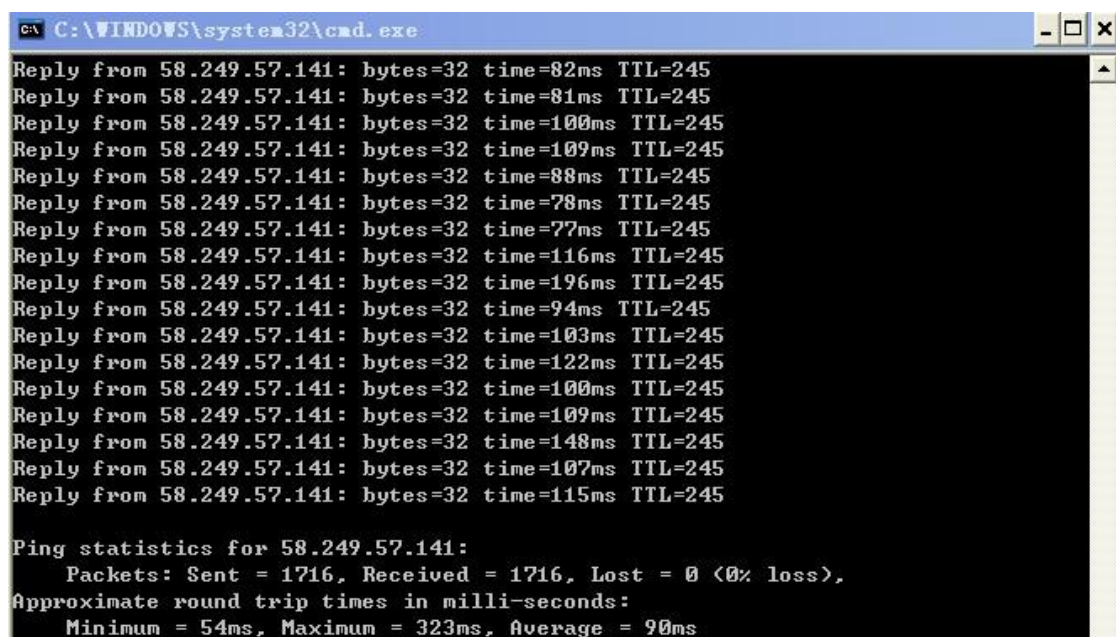

```
ca\ C:\WINDOWS\system32\cmd.exe
Reply from 58.249.57.141: bytes=32 time=82ms TTL=245
Reply from 58.249.57.141: bytes=32 time=81ms TTL=245
Reply from 58.249.57.141: bytes=32 time=100ms TTL=245
Reply from 58.249.57.141: bytes=32 time=109ms TTL=245
Reply from 58.249.57.141: bytes=32 time=88ms TTL=245
Reply from 58.249.57.141: bytes=32 time=78ms TTL=245
Reply from 58.249.57.141: bytes=32 time=77ms TTL=245
Reply from 58.249.57.141: bytes=32 time=116ms TTL=245
Reply from 58.249.57.141: bytes=32 time=196ms TTL=245
Reply from 58.249.57.141: bytes=32 time=94ms TTL=245
Reply from 58.249.57.141: bytes=32 time=103ms TTL=245
Reply from 58.249.57.141: bytes=32 time=122ms TTL=245
Reply from 58.249.57.141: bytes=32 time=100ms TTL=245
Reply from 58.249.57.141: bytes=32 time=109ms TTL=245
Reply from 58.249.57.141: bytes=32 time=148ms TTL=245
Reply from 58.249.57.141: bytes=32 time=107ms TTL=245
Reply from 58.249.57.141: bytes=32 time=115ms TTL=245

Ping statistics for 58.249.57.141:
    Packets: Sent = 1716, Received = 1716, Lost = 0 (0% loss),
    Approximate round trip times in milli-seconds:
        Minimum = 54ms, Maximum = 323ms, Average = 90ms
```

Figure 20: Ping 58.249.57.141

```

C:\WINDOWS\system32\cmd.exe
Reply from 58.248.37.17: bytes=32 time=75ms TTL=244
Reply from 58.248.37.17: bytes=32 time=64ms TTL=244
Reply from 58.248.37.17: bytes=32 time=83ms TTL=244
Reply from 58.248.37.17: bytes=32 time=82ms TTL=244
Reply from 58.248.37.17: bytes=32 time=81ms TTL=244
Reply from 58.248.37.17: bytes=32 time=80ms TTL=244
Reply from 58.248.37.17: bytes=32 time=79ms TTL=244
Reply from 58.248.37.17: bytes=32 time=78ms TTL=244
Reply from 58.248.37.17: bytes=32 time=77ms TTL=244
Reply from 58.248.37.17: bytes=32 time=76ms TTL=244
Reply from 58.248.37.17: bytes=32 time=85ms TTL=244
Reply from 58.248.37.17: bytes=32 time=75ms TTL=244
Reply from 58.248.37.17: bytes=32 time=74ms TTL=244
Reply from 58.248.37.17: bytes=32 time=73ms TTL=244
Reply from 58.248.37.17: bytes=32 time=82ms TTL=244
Reply from 58.248.37.17: bytes=32 time=91ms TTL=244
Reply from 58.248.37.17: bytes=32 time=80ms TTL=244

Ping statistics for 58.248.37.17:
    Packets: Sent = 1670, Received = 1670, Lost = 0 (0% loss),
    Approximate round trip times in milli-seconds:
        Minimum = 57ms, Maximum = 221ms, Average = 81ms

```

Figure 21: Ping 58.248.37.17

```

C:\WINDOWS\system32\cmd.exe
Reply from 58.248.37.16: bytes=32 time=75ms TTL=244
Reply from 58.248.37.16: bytes=32 time=75ms TTL=244
Reply from 58.248.37.16: bytes=32 time=73ms TTL=244
Reply from 58.248.37.16: bytes=32 time=72ms TTL=244
Reply from 58.248.37.16: bytes=32 time=71ms TTL=244
Reply from 58.248.37.16: bytes=32 time=80ms TTL=244
Reply from 58.248.37.16: bytes=32 time=79ms TTL=244
Reply from 58.248.37.16: bytes=32 time=78ms TTL=244
Reply from 58.248.37.16: bytes=32 time=77ms TTL=244
Reply from 58.248.37.16: bytes=32 time=76ms TTL=244
Reply from 58.248.37.16: bytes=32 time=75ms TTL=244
Reply from 58.248.37.16: bytes=32 time=74ms TTL=244
Reply from 58.248.37.16: bytes=32 time=83ms TTL=244
Reply from 58.248.37.16: bytes=32 time=82ms TTL=244
Reply from 58.248.37.16: bytes=32 time=80ms TTL=244
Reply from 58.248.37.16: bytes=32 time=79ms TTL=244
Reply from 58.248.37.16: bytes=32 time=77ms TTL=244

Ping statistics for 58.248.37.16:
    Packets: Sent = 1648, Received = 1648, Lost = 0 (0% loss),
    Approximate round trip times in milli-seconds:
        Minimum = 58ms, Maximum = 258ms, Average = 81ms

```

Figure 22: Ping 58.248.37.16

```

C:\WINDOWS\system32\cmd.exe
Reply from 116.21.75.17: bytes=32 time=391ms TTL=114
Reply from 116.21.75.17: bytes=32 time=480ms TTL=114
Reply from 116.21.75.17: bytes=32 time=431ms TTL=114
Reply from 116.21.75.17: bytes=32 time=280ms TTL=114
Reply from 116.21.75.17: bytes=32 time=348ms TTL=114
Reply from 116.21.75.17: bytes=32 time=457ms TTL=114
Reply from 116.21.75.17: bytes=32 time=416ms TTL=114
Reply from 116.21.75.17: bytes=32 time=434ms TTL=114
Reply from 116.21.75.17: bytes=32 time=354ms TTL=114
Reply from 116.21.75.17: bytes=32 time=364ms TTL=114
Reply from 116.21.75.17: bytes=32 time=353ms TTL=114
Reply from 116.21.75.17: bytes=32 time=383ms TTL=114
Reply from 116.21.75.17: bytes=32 time=333ms TTL=114
Reply from 116.21.75.17: bytes=32 time=382ms TTL=114
Reply from 116.21.75.17: bytes=32 time=401ms TTL=114
Reply from 116.21.75.17: bytes=32 time=421ms TTL=114
Reply from 116.21.75.17: bytes=32 time=421ms TTL=114

Ping statistics for 116.21.75.17:
    Packets: Sent = 1570, Received = 1561, Lost = 9 (0% loss),
    Approximate round trip times in milli-seconds:
        Minimum = 153ms, Maximum = 624ms, Average = 331ms

```

Figure 23: Ping 116.21.75.17

```

C:\WINDOWS\system32\cmd.exe
Reply from 202.108.22.142: bytes=32 time=132ms TTL=53
Reply from 202.108.22.142: bytes=32 time=141ms TTL=53
Reply from 202.108.22.142: bytes=32 time=130ms TTL=53
Reply from 202.108.22.142: bytes=32 time=129ms TTL=53
Reply from 202.108.22.142: bytes=32 time=129ms TTL=53
Reply from 202.108.22.142: bytes=32 time=129ms TTL=53
Reply from 202.108.22.142: bytes=32 time=129ms TTL=53
Reply from 202.108.22.142: bytes=32 time=129ms TTL=53
Reply from 202.108.22.142: bytes=32 time=129ms TTL=53
Reply from 202.108.22.142: bytes=32 time=129ms TTL=53
Reply from 202.108.22.142: bytes=32 time=129ms TTL=53
Reply from 202.108.22.142: bytes=32 time=129ms TTL=53
Reply from 202.108.22.142: bytes=32 time=129ms TTL=53
Reply from 202.108.22.142: bytes=32 time=139ms TTL=53
Reply from 202.108.22.142: bytes=32 time=139ms TTL=53
Reply from 202.108.22.142: bytes=32 time=138ms TTL=53

Ping statistics for 202.108.22.142:
    Packets: Sent = 1520, Received = 1513, Lost = 7 (0% loss),
    Approximate round trip times in milli-seconds:
        Minimum = 113ms, Maximum = 306ms, Average = 132ms

```

Figure 24: Ping 202.108.22.142



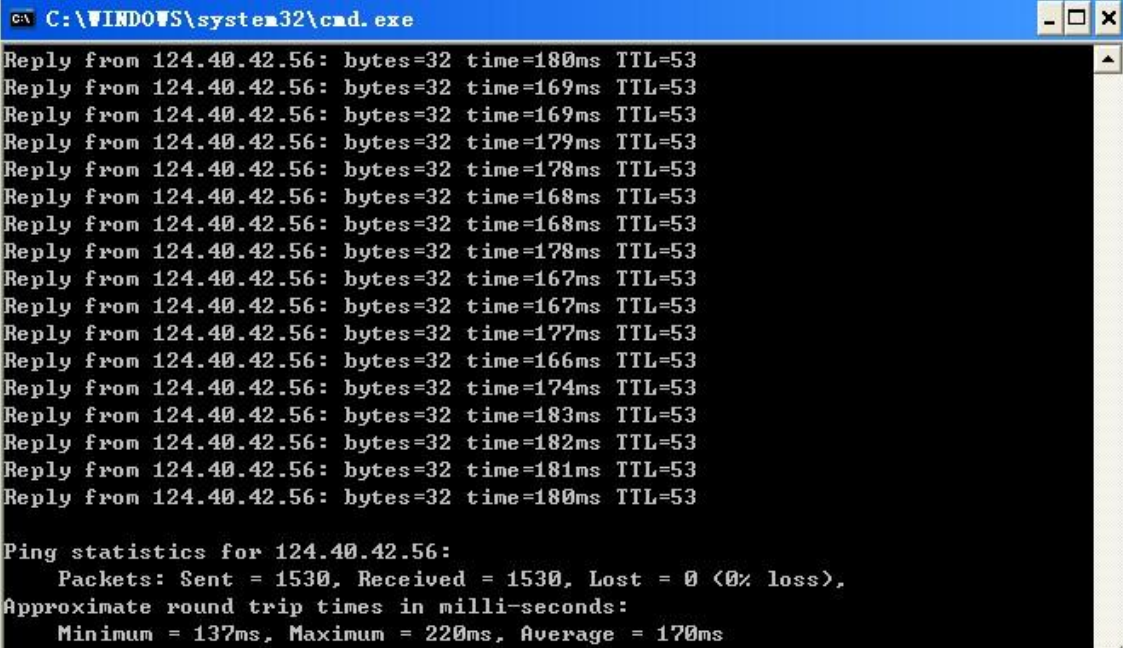

```
C:\WINDOWS\system32\cmd.exe
Reply from 124.40.42.56: bytes=32 time=180ms TTL=53
Reply from 124.40.42.56: bytes=32 time=169ms TTL=53
Reply from 124.40.42.56: bytes=32 time=169ms TTL=53
Reply from 124.40.42.56: bytes=32 time=179ms TTL=53
Reply from 124.40.42.56: bytes=32 time=178ms TTL=53
Reply from 124.40.42.56: bytes=32 time=168ms TTL=53
Reply from 124.40.42.56: bytes=32 time=168ms TTL=53
Reply from 124.40.42.56: bytes=32 time=178ms TTL=53
Reply from 124.40.42.56: bytes=32 time=167ms TTL=53
Reply from 124.40.42.56: bytes=32 time=167ms TTL=53
Reply from 124.40.42.56: bytes=32 time=177ms TTL=53
Reply from 124.40.42.56: bytes=32 time=166ms TTL=53
Reply from 124.40.42.56: bytes=32 time=174ms TTL=53
Reply from 124.40.42.56: bytes=32 time=183ms TTL=53
Reply from 124.40.42.56: bytes=32 time=182ms TTL=53
Reply from 124.40.42.56: bytes=32 time=181ms TTL=53
Reply from 124.40.42.56: bytes=32 time=180ms TTL=53

Ping statistics for 124.40.42.56:
    Packets: Sent = 1530, Received = 1530, Lost = 0 (0% loss),
    Approximate round trip times in milli-seconds:
        Minimum = 137ms, Maximum = 220ms, Average = 170ms
```

Figure 25: Ping 124.40.42.56