

To2052m5
24 JAN 1992

INSTITUTE OF
TERRESTRIAL
ECOLOGY
MERLEWOOD



**Institute of
Terrestrial
Ecology**



ITE has administrative headquarters north and south, and the geographical distribution of its 250 staff in six Research Stations throughout Britain allows efficient use of resources for regional studies and provides an understanding of local ecological and land use characteristics.

This report is an official document prepared under contract between the customer and the Natural Environment Research Council. It should not be quoted without the permission of both the Institute of Terrestrial Ecology and the customer.

ITE NORTH

Edinburgh Research Station
(Admin HQ for ITE North)
Bush Estate
Penicuik
Midlothian EH26 0QB
Tel: 031 445 4343; Telex 72579
Fax: 031 445 3943

Banchory Research Station
Hill of Brathens
Glassel
Banchory
Kincardineshire AB31 4BY
Tel: 033 02 3434
Fax: 033 02 3303

Merlewood Research Station
Grange-over-Sands
Cumbria LA11 6JU
Tel: 05395 32264; Telex 65102
Fax: 05395 34705

ITE SOUTH

Monks Wood Experimental Station
(Admin HQ for ITE South)
Abbots Ripton
Huntingdon
Cambs PE17 2LS
Tel: 048 73 381; Telex 32416
Fax: 048 73 467

Bangor Research Unit
University College of North Wales
Deiniol Road
Bangor
Gwynedd LL57 2UP
Tel: 0248 370045; Telex 61224
Fax: 0248 355365

Furzebrook Research Station
Wareham
Dorset BH20 5AS
Tel: 0929 551518
Fax: 0929 551087

The ITE Research Marketing Officers for ITE North and South are based at Banchory and Monks Wood, respectively.

INSTITUTE OF TERRESTRIAL ECOLOGY

(NATURAL ENVIRONMENT RESEARCH COUNCIL)

Project T02052M5

COUNTRYSIDE SURVEY 1990

Mapping the land cover of Great
Britain using satellite remote
sensing: a demonstrator project
in remote sensing.

Second Interim Report to the
British National Space Centre

R M Fuller, A R Jones, G B Groom & A G Thomson* and N J Brown

Jointly funded by
The Natural Environment Research Council
The British National Space Centre
(Department of Trade and Industry)
The Department of Environment

Environmental Information Centre
Institute of Terrestrial Ecology
Monks Wood Experimental Station
Abbots Ripton, Huntingdon
Cams PE17 2LS

* ITE Bangor

January 1992



CONTENTS

	Page
SUMMARY	2
INTRODUCTION	3
THE AIMS OF THE REMOTE SENSING IN COUNTRYSIDE 1990	4
THE AIMS OF THIS REPORT	4
SCHEDULE OF WORK	5
THE SAMPLE-BASED FIELD SURVEY	8
LAND COVER MAPPING FROM SATELLITE IMAGES	9
FORWARD LOOK FOR 1992	38
CONCLUSIONS	38
REFERENCES	39
ACKNOWLEDGEMENTS	40
TABLE 1	17
TABLE 2	18
TABLE 3	28

SUMMARY

1. Landsat satellite images are being used to compile a digital map of land cover of Great Britain, complete with estimates of accuracy.
2. Maps are being integrated with sample-based, field survey data; the study will demonstrate use of results in a vector GIS.
3. This report outlines methods, reviews the work schedule, records availability of imagery, identifies target land cover classes, outlines progress in analyses and presents a forward look for the coming year.
4. The study uses combined summer and winter data to help accurately distinguish target classes. Images, covering c.85% of Britain, have already been purchased; the cover will be completed by choosing from existing images, supplemented with new material, acquired by mid-1992.
5. These images are being geometrically corrected to a 25 m grid-cell, registered to National Grid, before combining as a 6-band composite image (using red, near IR and middle IR bands from each of the summer and winter images).
6. Target classes number 25 types, now shown to be suitable for coverage of all Britain. The present list includes 16 seminatural vegetation types (some managed for agriculture and forestry), 2 water classes, 2 bare and 5 man-made cover types including arable and developed land.
7. Interactive 'training' identifies sample areas of the target classes, from which extrapolations classify whole scenes, using a maximum likelihood method. An iterative procedure, with built-in checks, is used to derive accurate end-products. Final validation will compare the cover-maps with detailed field maps of 533, one kilometre, squares, recorded in 1990.
8. 'Knowledge based' corrections are made, where necessary to correct systematic errors: for example, a coastline is defined, where needed, to remove confusion between maritime and terrestrial cover-types.
9. The schedule of work is given and indicates that the proposed timetable is realistic.
10. In the calendar year 1992, the aim will be to complete the classification of Britain, to undertake most of the validation, and to mosaic scenes into continuous cover-maps for 100 km squares.



INTRODUCTION

There has been no complete map of the land cover of Britain since the early 1960s (Coleman & Maggs 1965) and no published map since that made in the 1930s (Stamp 1962). The process of land use planning in Britain has been based, at best, on piecemeal surveys, which are often incomplete and maybe incompatible. Experiments with Landsat Thematic Mapper (TM) images, especially studies in lowland Cambridgeshire and upland Snowdonia (Fuller et al. 1989 a & b, Jones & Wyatt, 1989; Fuller & Parsell, 1990; Griffiths & Wooding, 1989), have shown that the data are capable of providing information on major cover types and land uses, at field by field scale, for all of Britain. The use of composite summer/winter data has proved particularly useful to improve the detail and accuracy available from satellite imagery (Fuller & Parsell 1990).

This is the second Interim Report of this project, describing a programme of work to compile a national, digital, land cover map. The product is an integral part of the Countryside 1990 survey, which aims to provide information on the land use and ecology of Great Britain in 1990, to assess past changes, and is a baseline against which to measure changes in the future.

THE AIMS OF THE REMOTE SENSING IN COUNTRYSIDE 1990

1. To compile a digital map of land cover in Great Britain, based on a hierarchical classification of important major land cover types.
2. To make quantitative assessments of accuracy of end-products.
3. To integrate the map with the field survey data of Countryside 1990 and with other topographic and thematic data in a Geographical Information System (GIS) environment.
4. To produce demonstrator GIS output in vector format.

THE AIMS OF THIS REPORT

To record progress as at December 1991, specifically:

1. To record image-availability and purchases
2. To identify and justify a list of target land cover classes
3. To describe methods
4. To outline progress in analyses
5. To record summaries of results
6. To outline a programme of work for the next year

SCHEDULE OF WORK

The methods involve two distinct elements (Figure 1). First, a very detailed field survey was based on a stratified random sample of 1 km British National Grid (BNG) squares (Barr 1990). Second, a more generalised census is based on computer classification of satellite images.

The satellite mapping involves geometric correction of summer and winter scenes, co-registration of summer-winter pairs of scenes, field reconnaissance of sample areas, maximum likelihood classification based on field reconnaissance, followed by validation; thereafter, the data are integrated into full cover-maps and GIS, then used in demonstration projects. These stages are summarised in Figure 2.

Figure 1

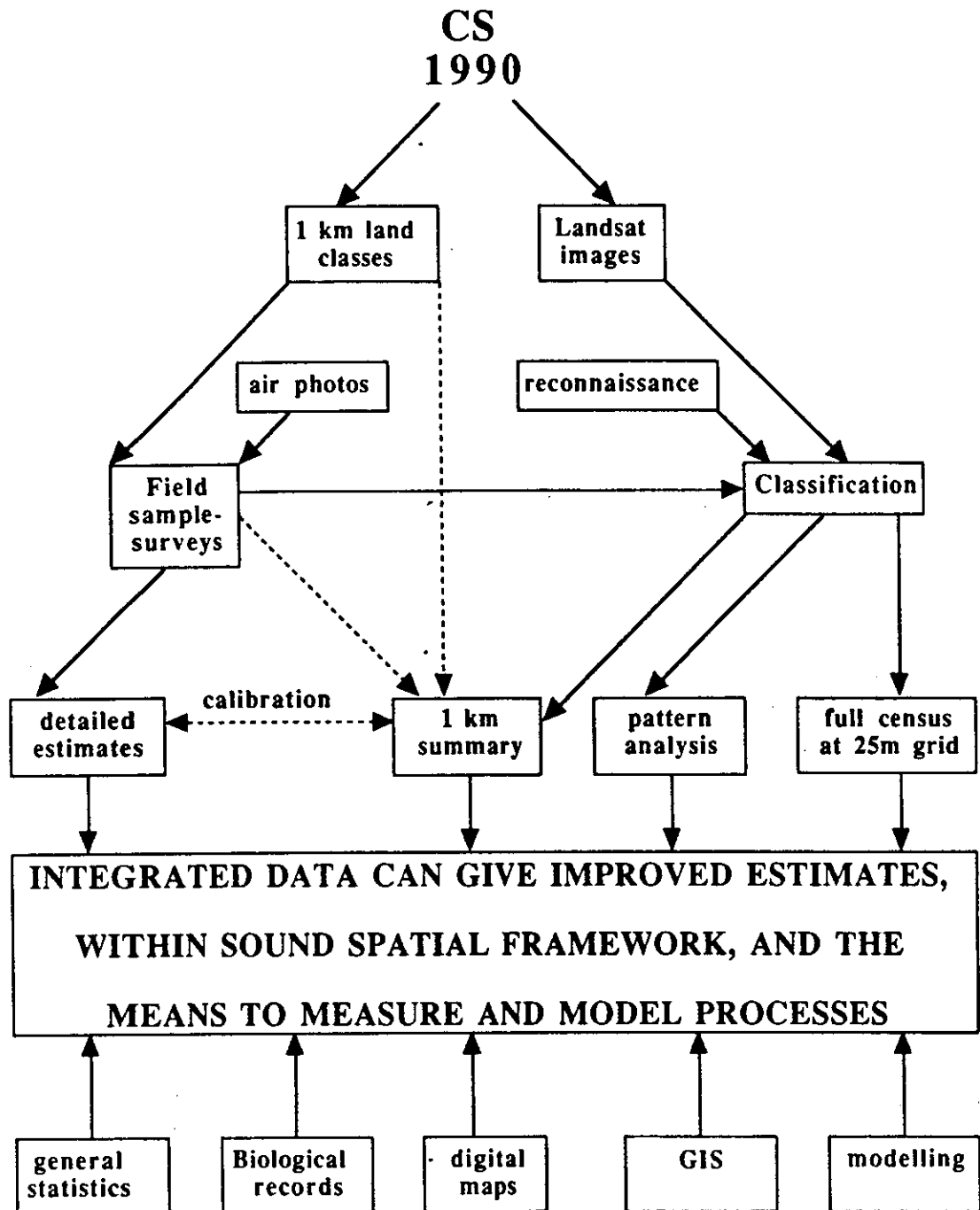

Countryside 1990 - the relationships between the field and satellite surveys

Figure 2

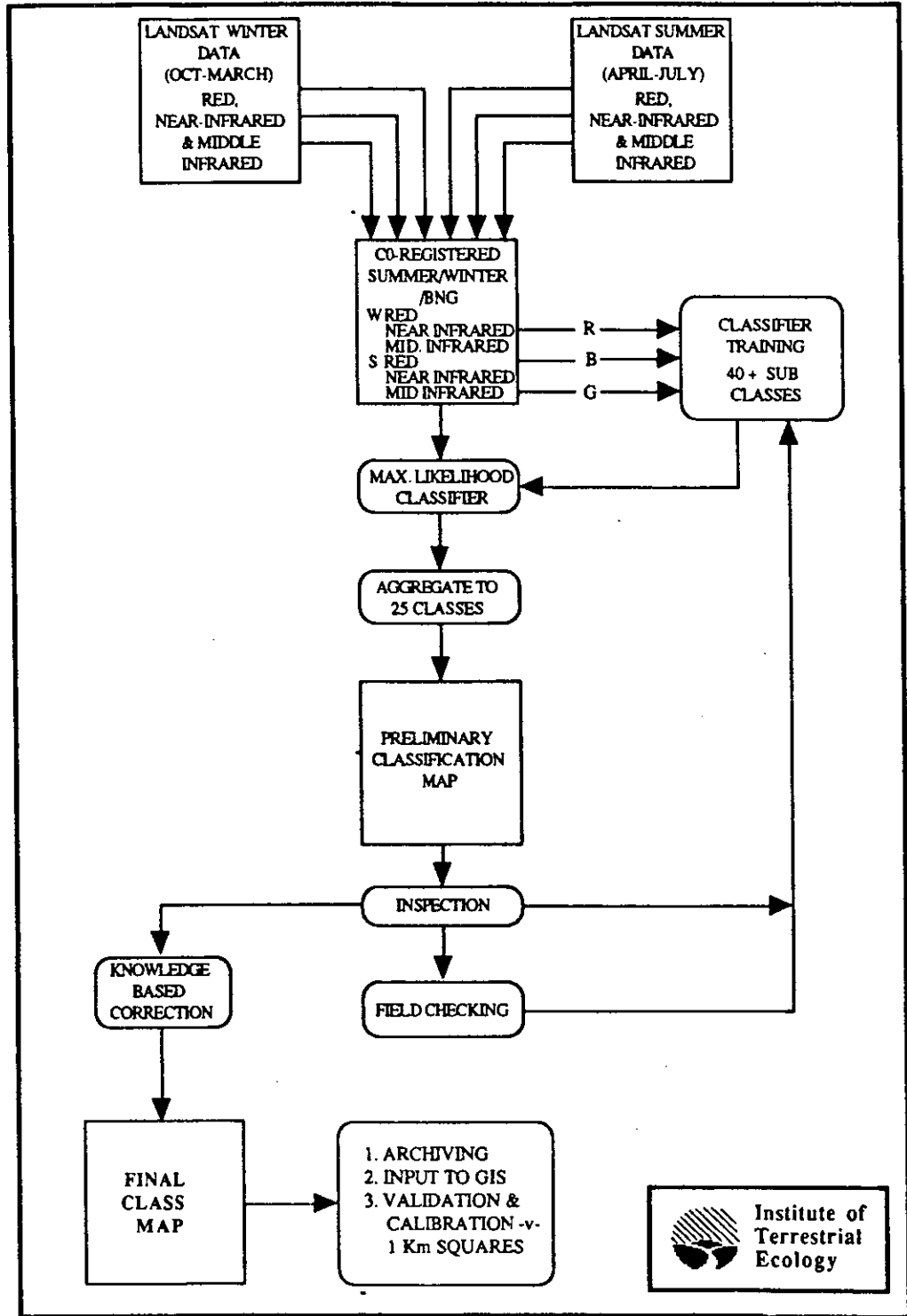

Diagram summarising methods used to produce land cover maps of Great Britain

THE SAMPLE-BASED FIELD SURVEY

STRATIFICATION

The stratification of the field-survey used a computer-classification of all Ordnance Survey, National Grid, 1 km squares in Britain. This derived summary data from thematic and topographic maps; the data were then used to make a multivariate analysis to give 32 land classes and allocate each square to one of the 32 classes (Bunce & Heal 1984). A stratified random sample of 508 squares was chosen with the sample-size weighted according to the National extent of each class. This sample was used for detailed field survey.

FIELD RECORDING OF 1 KM SQUARES

The sample-based field survey was successfully completed in late summer 1990. Summary methods were published by Barr (1990). Fuller details appear in Countryside Survey (CSS) Report 90/7 to the Department of Environment (CSS 1990). Field-surveyors annotated maps, which included OS outlines supplemented with airphoto-interpreted vegetation boundaries, linear and point features (eg hedges, trees). Field-records gave ground cover, plant species dominance, land use, with specific information on linear and point features, and detailed plant-quadrat data at selected sites. The field data are being digitised within an ArcInfo GIS to form GIS files for each square, with species- and other attribute-data held on an ORACLE database.

DIGITISING

The digitising of field survey maps at ITE Merlewood has been completed for c. 40 squares; the remaining 470 have had all linear features digitised, with completion now expected in summer 1992. Nine examples have been passed to Monks Wood for pilot studies in the integration with satellite maps. This involved transfer from the ArcInfo GIS to a Laserscan system - details are given in the section on validation.

LAND COVER MAPPING FROM SATELLITE IMAGES

LANDSAT IMAGE COVER

Eight Landsat paths cover Britain (Figure 3). The orbits overlap very substantially in these northern latitudes, from about 45% in southern England, and exceeding 50% from the Scottish border northwards. This means that it is possible to use alternate paths of data in Scotland to still achieve full cover but, in England, it is necessary to buy every path. Note, however, that paths may vary slightly - this is clearly evident in a plot of the quick-looks used in the NRSC's 'Landsat 4 & 5 Worldwide Reference Index for the British Isles' (see Figure 4). The choice of alternate scenes must be made on individual merit.

The land cover mapping involves computer classification of paired summer and winter Landsat Thematic Mapper (TM) scenes to give 25 land cover types based on a 25 m grid. The baseline date for the mapping is 1990 but, to accommodate any image shortages, an extended period of plus or minus an expected 2 years is allowed.

DEFINITION OF SUMMER AND WINTER IMAGES

This study uses summer and winter data, in composite, to help separate the various target classes. So, for example, arable areas alternate between full plant cover and bare ground in a year, semi-natural vegetation retains full cover; deciduous trees are distinguished from evergreens; deciduous rough grasslands differ from permanently green agricultural grasslands; urban areas and bare ground are distinguished by their bare appearance in summer and winter. (Fuller & Parsell, 1990).

The appropriate definition of 'winter' and 'summer' has been clarified in discussion with ecologists and agriculturalists, who are familiar with the phenology of the local vegetation in various regions of Britain. The consensus is that the summer period safely includes May to July, inclusive, that August to mid-October represents a transition period and that winter covers the time from mid-October (in practice the date of the first frosts) to around mid-March. Late March and April are transition periods which are best avoided in the selection of summer-winter images. In practice, the useful periods shift with altitude; they also vary from north to south and east and west in Britain and are inevitably dependent on the year in question. Therefore it is essential to take summer/winter pairs on their own merit, taking advice based on local knowledge of vegetation, cropping and climate.

IMAGE SEARCH

The search for images is based on National Remote Sensing Centre quick-look photographs of TM images acquired by Landsat within the study period. The library of quick-looks, 1988 to June 1990, was examined as a starting point. Cloud-free scenes and quarter-scenes were identified from these. Note that the DOE part-funding has placed a priority on processing data for England and Wales; also that Scotland is the subject of a Macaulay Land Use Research Institute (MLURI) land cover mapping project which lessens our priority for Scottish cover. However, image-availability has been the ultimate determinant of the timetable for image processing.

Figure 3

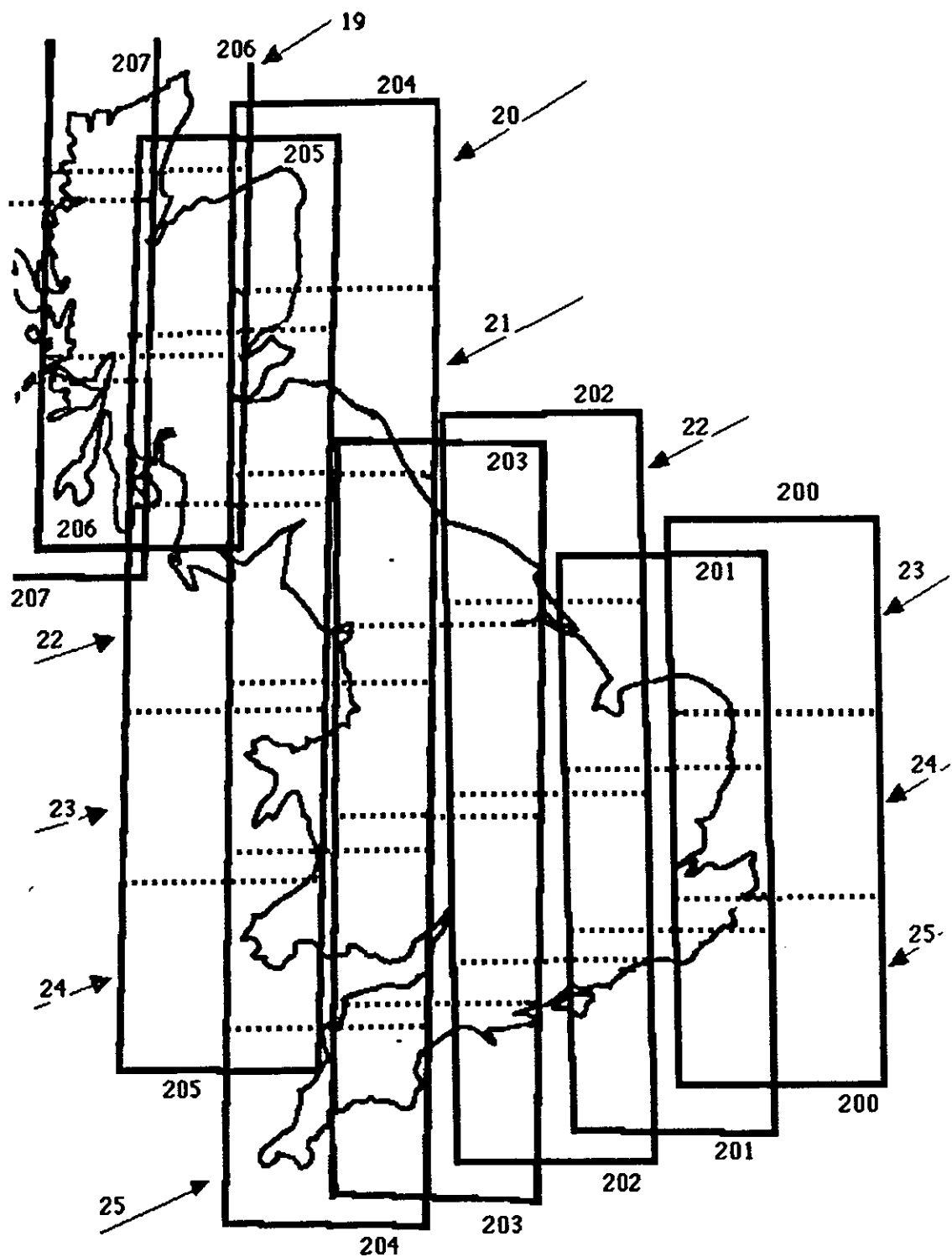

Landsat paths covering Great Britain

Figure 4

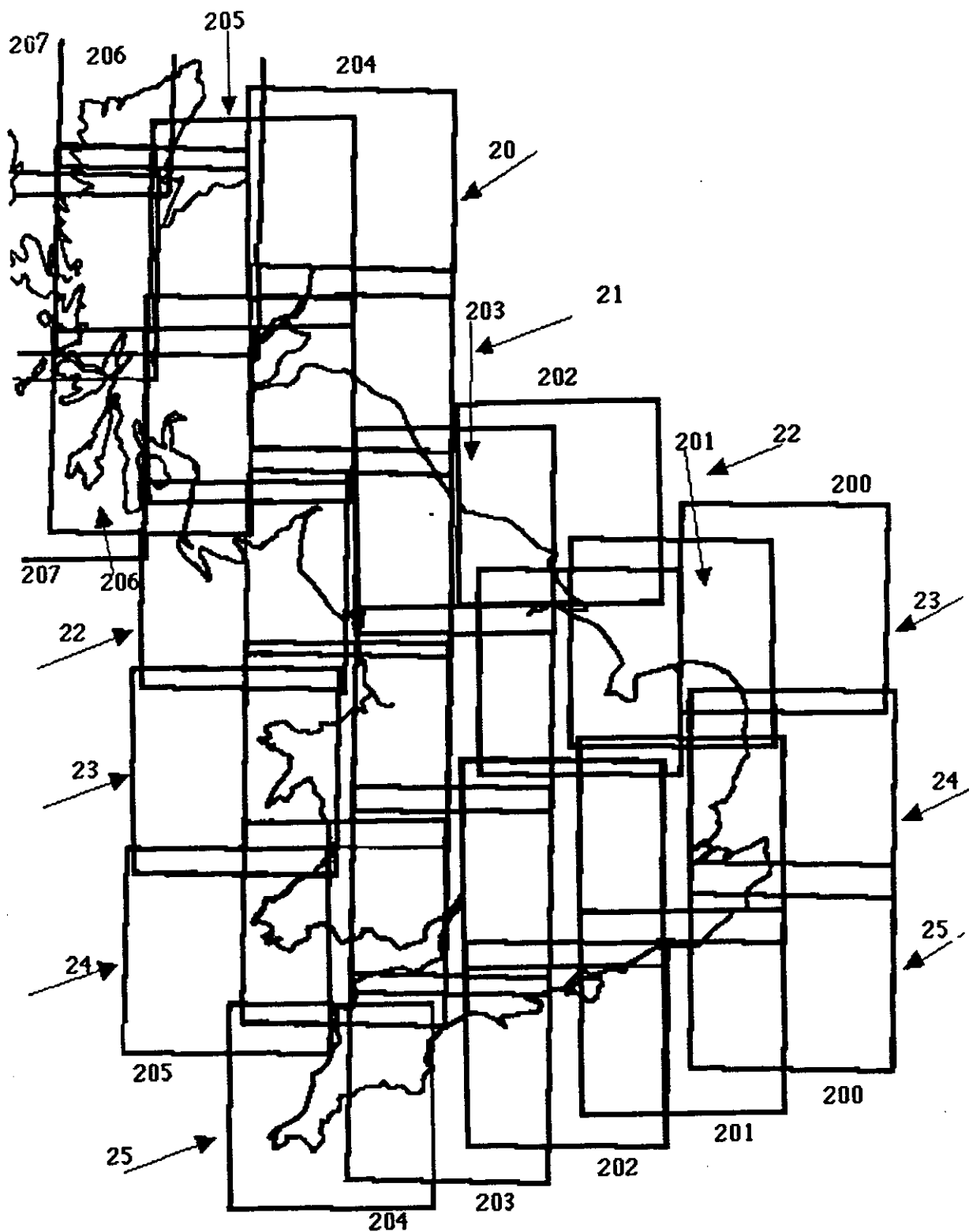

A plot of positions of Landsat scenes as shown on the 'Landsat 4 and 5 Worldwide Reference for the British Isles'

The NRSC continue to send new quick-looks to ITE Monks Wood for continued updates of the evaluations (usually running up to one month behind the current date). By 5.12.90. we had examined quick-looks of cover up imaged 21.11.90. We also have listings of those scenes which have been acquired as archive material. It is then possible to build up a picture of suitable imagery which is immediately available from the NRSC and imagery which could be purchased, via the NRSC, from Eurimage.

Results indicate that, even without any new acquisitions, the summer-winter coverage of Britain is 95% complete, with the remaining 5% being imaged on one or other date. A satisfactory conclusion will not be constrained by data-shortages, as single images can be used in those regions where multi-date composites are not available. The winter data are those generally missing in the 5% of Britain where coverage is incomplete. Hopefully, the remainder of winter 1991-92 will fill all gaps in the coverage. Figure 5 shows those scenes already purchased for analysis. Images in stock amount to cover of about three-quarters of Britain.

SCHEDULE OF PROCESSING

The study is expected to involve the processing of about 60 quarter-scenes of combined summer and winter data (Figure 5). In many cases these will be in the form of full scenes, elsewhere they will be individual quarter scenes. The net result will be a total of about 30 summer-winter paired scenes and part-scenes to analyse.

The overlap between images means that alternate paths can provide near full cover, so intervening paths may be required to provide just a 10-20 km ribbon of data to the map (except where scattered cloud-cover mars adjacent scenes). Thus, in all, about 18 main-path scenes or part-scenes will require detailed attention in classification, and about 8 intervening scenes will be classified more quickly (in perhaps half the time). Taking the allowed period of nine quarters, we would expect to classify an average of 2 main-path images and 1 intervening image per quarter. Initial purchases and analyses of data have concentrated on the 'main' paths.

In the early stages of processing, when methods were being developed and tested, the analyses proceeded more slowly, but as routines were developed, the rate of map production has increased. Figure 6 records the planned schedule of activities and the progress to date. Figure 5 illustrates the coverage of images and their status in processing.

'HOUSEKEEPING'

The successful conclusion of such a complex project, with vast quantities of data, undergoing many processes before completion, and drawing on several members of staff, requires careful attention to detail. To ensure the smoothest possible flow, 1.4 gigabytes of computer disk storage has been dedicated to this project, allowing each summer and winter pair, for each scene, to be corrected, amalgamated, and classified with the minimum of file deletion to create space. A standard nomenclature has been derived for file handling to ensure that any team member can identify any listed file, and immediately assess progress. A micro-computer based reference system has also been created to allow easy retrieval of project information in map form. The sequence of maps has been made available to DTI with each quarterly report (Figure 5).

Figure 5

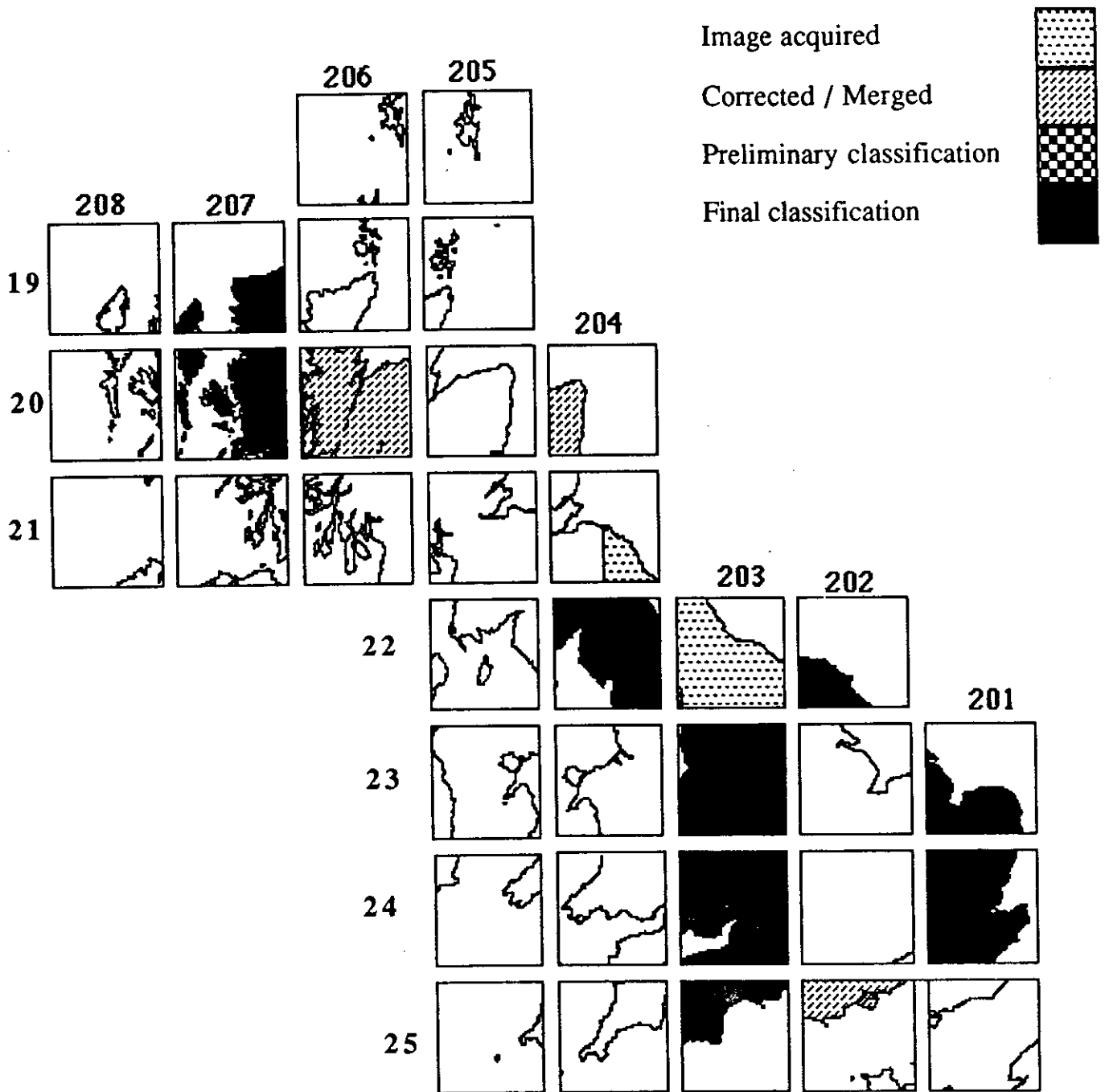

Status of data processing, December 1991.

Figure 6

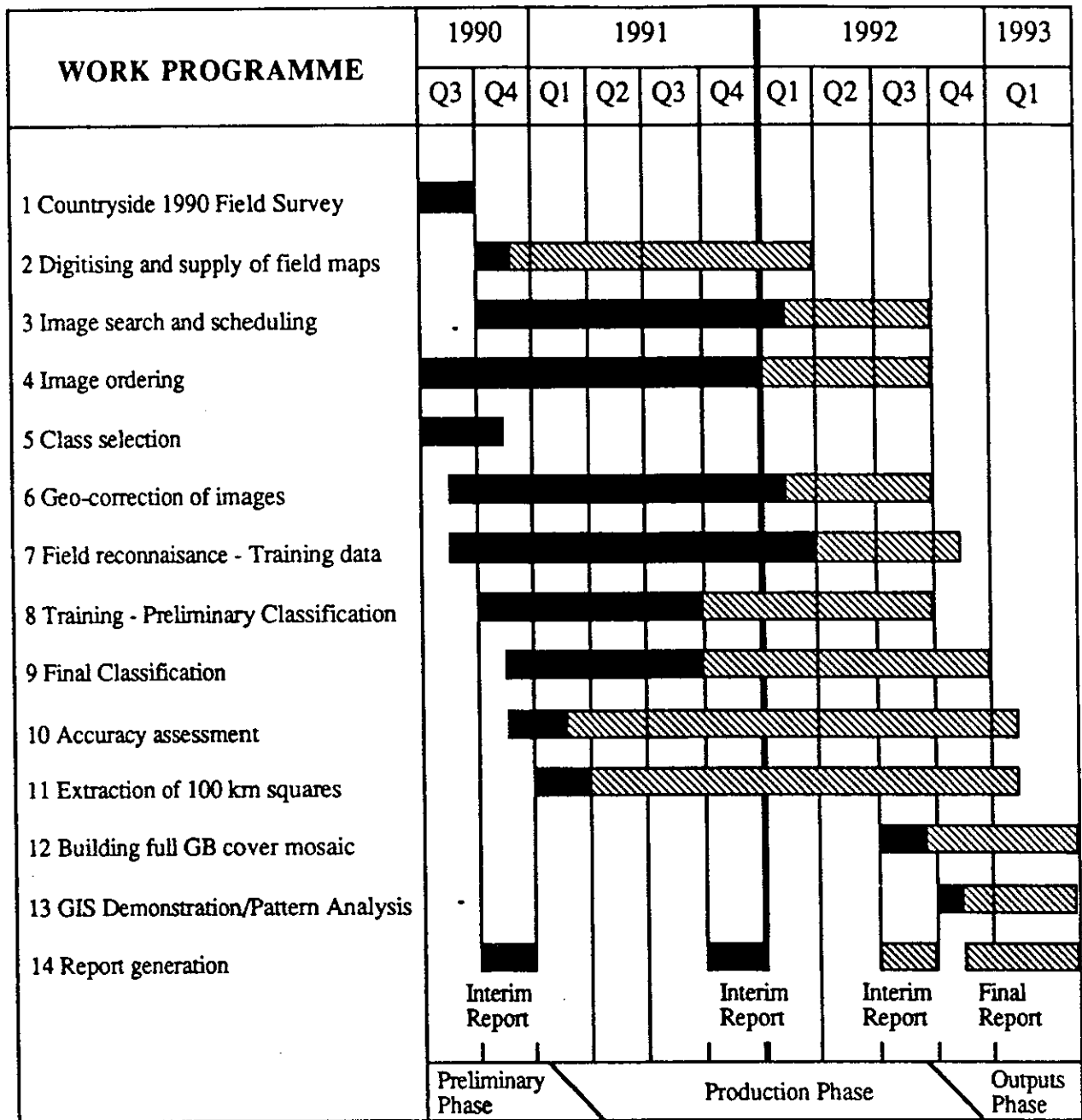

Planned schedule of activities and progress to date (black bars), December 1991.

GEOMETRIC CORRECTION AND IMAGE CO-REGISTRATION

Landsat TM data are geometrically corrected to BNG. Many images have been purchased from NRSC as geometrically corrected scenes. Otherwise, control points are defined interactively on the International Imaging Systems (IIS) M75 image processor. The procedure uses 1:50 000 Ordnance Survey maps mounted on a digitising table, to derive 'true' position of control points identified on the input image. The relationship between image-coordinates and BNG is calculated using a polynomial model. The image is then resampled to fit this polynomial model, to produce an output image of a chosen pixel size (here, 25 m), with a BNG map projection.

Various algorithms are available for deriving interpolated DN values for pixels in the new output grid. Nearest neighbour and cubic convolution resampling schemes were considered. Earlier tests (Fuller & Parsell, 1990) indicated that neither method produced consistently more accurate classmaps. The nearest neighbour algorithm better preserved boundaries, whilst the cubic method smoothed variations, tending to remove odd, misclassified, within-field, pixels. However, smoothing algorithms, applied after classification, may do this job as effectively. The conclusion was that cubic convolution resampling, which best models the natural variations in radiance across an image, is most appropriate for use here. It will give better within-field classification with less 'noise'. Furthermore, the field survey of CS 1990 is designed to give quantitative assessments of linear features. The strength of remote sensing is in its use for studying areal features, so the choice of resampling algorithm accords with this.

Cubic convolution is therefore used to derive output pixel values which are written into the new 25 m grid cells of the corrected image. Corrections aim to achieve a sub-pixel (ie <25 m) mean residual error at control points. This was true of both the NRSC- and ITE-corrected images. Figure 5 shows which scenes have been geometrically corrected to date.

The summer/winter composite images are made by co-registering scenes or part scenes to give a single output image. This image contains six bands of data, three each from the original summer and winter data, namely Landsat TM bands 3,4 and 5 - ie red, near and middle infrared. These bands were chosen because they represent wavelengths with characteristic reflectances from vegetation, and are less affected by haze-problems than the blue-green end of the visible spectrum (Fuller *et al.* 1989, Fuller & Parsell 1990).

CLASS SELECTION

Class selection (Appendix 1) has been influenced, by user requirements, by reference to other surveys (Table 1), but ultimately by what is feasible, with acceptable levels of error. A consultative exercise has been undertaken, as given in the First Interim Report (Table 2). This produced 15 written responses and several telephoned replies, all generally favourable.

Some responses showed that users would like more detail, others felt the list over-ambitious; and comments on specific classes were often contradictory. The distinctions between upland and lowland heaths and upland and lowland grasslands were thought by some to be artificial, based on subdividing a continuum. Knowledge-based separation would seem better than attempting to use spectral differences. Furthermore, a GIS can tailor the definition to specific user-requirements. But

Table 1. (overleaf)

A preliminary list of land cover classes and their relation to other recent land cover surveys. Note that the number of classes increased from this original list of 22 cover types to 25 cover types after the consultation exercise.

Key to Table 1

SURVEY	ORGANISATION/DATE
<u>CS 1990</u> Countryside 1990	ITE/DOE/DTI 1990-
<u>ECOLUC</u> Ecology of Land Use Change	ITE/DOE 1984-9
<u>MLC</u> Monitoring Landscape Change	NRSC/Huntings/DOE 1984
<u>Landcov</u> Landcover Scotland	MLURI/SDD 1988-92
<u>CORINE</u> Coordination of Information on Environment	various/EEC 1986-90-?
<u>UN ECE</u> United Nations Economic & Social Council	Proposed stats class'n
<u>NCMS</u> National Countryside Monitoring Scheme	NCC 1985-
<u>Nat Parks</u> Monitoring Landscape Changes in National Parks	Silsoe/CC 1989-
<u>%</u> Percent Cover	Bunce & Jenkins 1989

TABLE 1

LANDSAT CLASS	CS 1990	ECOLUC/NRSC	MILC	LANDCOV SCOTLAND	CORINE	UN ECE	NRCS	NAT PARKS	%
sea/estuary	sea 38	-	F1 coast/estuary	-	5.2.1 lagoon 5.2.2 estuary 5.2.3 sea	7.2 tidal water	-	F1 open water coastal or estuarine	-
inland water	water 51-55	-	F2 open water	water 18	5.1.1 water cse 5.1.2 water body	7.1 inland water open water	-	F2 open water inland	3.2
beach/flats	coastal 31-7	-	-	beach 23-5	3.3.1 beach 4.2.3 flats	6.2 beaches	-	G3 coastal features	1.9
saltmarsh	saltmarsh 116	-	F3c saltmarsh	saltmarsh 190	4.2.1 saltmarsh	-	-	-	-
grass heath	agricultural 101	-	G3 sand/shingle	marum dune 211	-	-	-	-	-
pasture/amenity grass	mown 145	agricultural grass	E2a pasture G4b amenity	improved 90-7 airfield 4 golf course 5	1.4.1 urban gr 1.4.2 sport 2.3.1 pasture 3.2.1 natural	3.9 recreation 1.3 meadow/past	semi-improved & improved grass, recreational	E2a improved	17.5
meadow/verge/unimproved	upland grass 102 calc 105, unimp'd 137	s'nat upland past upland pasture	E2b rough pasture E2c neglected past	smooth gr 150-3 155-8, 160-3 links 212-3	-	-	unimproved grass	E2b unimproved	5.2
fen/marsh/rough	bogs 111-4, herb 134, forb 138-40	-	F3b freshwater marsh	wetlands 200-3	4.1.1 marsh	4.1.2 lowland bog	lowland mirtu wet ground	F3 wetland veg	-
grass moor	moorland grass 103, bog 111	grass moor, mixed grass moor, bog	D2 upland grass moor, F3a peat bog	Nardus/Molinia 140-3, bogs 180-6, 220-3 burnt 112-3, 116-7 122-3, 126-7	4.1.2 peat bog	5.3 mountain grass 4.1.1 upland bog	blanket mire	D2 upland grass moor	8.9
burnt moor	burnt moor 144	burnt	-	-	-	-	-	-	-
upland dwarf shrub	moor shrub heath 104	heather, h+grass pioneer, bracken	D1 upland heath	wet h 120-1, 124-5 undiff'd 130-7	3.2.2 moor/heath	-	heather moor montane heath bracken	D1 upland heath h-grass mosaic D3 bracken	8.3 1.6
bracken	Pteridium 156	bracken	D3 bracken	bracken 170-3	-	-	-	-	-
heather heath	lowland hth 108	-	D4 lowland heath D5 gorse	dry heather 110-1 114-5	5.1 heath	-	maritime heath	D4 lowland heath	-
scrub/orchard	scrub 210, orchard 132	-	G4 scrub G1c orchard/hops	scrub 82	3.2.4 scrub 2.2.2 orchard	2.5 other wood 1.2 perma't crop	scrub orchard	C4 scrub	1.1
deciduous/mixed	trees 222, 231-52	broadleaf/mixed	C1 broadleaved C3 mixed wood C2 coniferous	broadleaved 76 undiff'd six 79 coniferous 70, 73	3.1.1 broadleaf 3.1.3 mixed wd 3.1.2 conifer	2.3 non-conifer 2.4 mixed 2.2 coniferous	b'leaved wood/ plant'n, mixed conifer wood/ plantation	C1 broadleaved C3 mixed forest C2 coniferous high forest	2.4 6.1
evergreen	trees 211, 223-8	conifer	-	-	-	-	-	-	-
arable	arable 14, 117-31, 143, ley 146	arable	E1a arable/akt gdn	arable 100-7	2.1.1 arable	1.1 arable 1.5 fallow	arable	E1 cultivated	28.6
ruderal weed	vacant 138 neglected 141 abandoned 142 residential 421	-	-	-	-	-	-	-	-
suburban	commerce 422 industry 423-6	developed	G3a housing G3c transport G3e derelict G2 rock G4d mineral	dev rural 1, 2, 3, 6 built-up 20 road 21, rail 22 bare 10-18, 210 felled 84	1.1.1 cont. urb 1.2 indust. 1, 3, 2 1.3.3 constr 1.3.1 extraction 3.3.2 rocks 3.3.3 sparse veg	3.1.1 1-2 storey 1.4 agri build 3.1.2 3+ storey 3.2.3 4, 3.5 dump 3.7, 3.8 dev'd	built	H3 isol'd rural H1 built up	13.0
urban/industrial	physiographic 1-16, quarry 432-3 felling 281	-	clear felled	-	-	-	recent felled	D7 peat, G2 rock H2 quarries C5 clear felled new plantings	0.7
bare	-	-	-	-	-	-	-	-	-
felled	-	-	-	-	-	-	-	-	-

CLASSES EXCLUDED FROM LANDSAT CLASSIFICATION

(NR limited area covered by NRSC, hence limited list of classes)

linear/points/misc. 56-67, 108-9, 115, 201-3, 146-56, 157-68, 175-97, 204-8, 215-8, 256-364, 427-31, 441-471, 501-524, 301-79, 401-8, 415-22, 431-73

A linear/small features
B isolated features

cloud 26
snow 27
4. mixed mosaic lines/points
recent plough wood 83
open canopy plantation 85

2.1.1 perw irrign
2.1.3 rice
2.2.2-3 vine, olive
2.4 heterogeneous agricultural Categories, undefined, sclerophyl labelled
4.2 Tundra
4.2.2 salines
6.1.2 snow
Categories, undefined, labelled
'other ****'

young plant'n
marginal inund'n
parkland

Table 2. A list of the organisations consulted regarding the land classes to be identified in the land cover mapping project.

Nature Conservancy Council
NERC/ESRC LUP
Scottish Development Department
Silsoe College
Birkbeck College, University of London
British Association of Remote Sensing Companies
British National Space Centre
British Trust for Ornithology
European Commission, Brussels
CLUWRR, Newcastle University
Countryside 1990 - Advisory Committee
Countryside Commission
Countryside Commission for Scotland
Department of Agriculture and Fisheries for Scotland
Department of the Environment, Air Quality, Rural Affairs
Department of Trade and Industry
Department of Transport
Economic and Social Research Council
FARMSTAT
Forestry Commission
Her Majesty's Inspector of Pollution
Hunting Surveys Ltd
Institute of Freshwater Ecology
Institute of Hydrology
Institute of Terrestrial Ecology (other stations)
Lands Tribunal for Scotland
Macaulay Land Use Research Institute
Ministry of Agriculture, Fisheries and Food
National Remote Sensing Centre
National Rivers Authority
Natural Environment Research Council Institutes
Nature Conservancy Council (and derivatives)
Rothamsted Experimental Station
Scottish Office
Silsoe College, Bedfordshire
Soil Survey Land Research Centre
University College London
University of York
University of Newcastle-upon-Tyne (NELUP)
Wageningen Agricultural University, Netherlands
Water Research Centre
Welsh Office
Wye College, Kent

simple rules, eg altitudinal zones, might disregard the confounding effects of latitude and longitude.

Some people noted that widespread classes (eg the agricultural grasslands) deserved further subdivision: this point is fully accepted, but comments of others rightly noted how difficult it was to relate reflectance differences in grasslands to real agricultural meaning: management practices can easily obscure the nature of the sward.

Some remarked on the rarity of some classes and questioned their choice as specific classes: this point is taken and in many cases we intend to simplify the classification by aggregating rarer classes (eg ruderal weeds) into related, more common, ones, at least for display purposes.

The consultation, coupled with our own growing experiences of fieldwork and classification, covering very diverse areas of Britain, has led us to adopt a strategy which was suggested in the consultation exercise. The target classes are achieved by defining a large number of spectrally unique subclasses. These will be aggregated to give the target classes (renamed to convey as exact a definition as is possible). However, because some may feel the separation of rarer or more difficult classes is inappropriate, we will present maps without the full range of distinctions - that is, like-classes will be coloured the same. Furthermore, the hierarchical nature of the classification would enable users to subdivide at very simple levels, eg land and water, vegetated and bare. Summary-statistics could use the same approach. However, the full subclass-details would be resident in the top layer of the cover-database, and readily accessible. The adopted classification is explained in detail in Appendix 1.

In summary, there would be a hierarchical classification: this could range from a few very basic cover-types, separated with high levels of accuracy. This classification would subdivide into a shortlist of 19 spectrally distinct major or 'key' classes (Figure 7); beyond these, the original list of 25 target classes (Figure 7) would be defined using extra contextual information; these details would not always carry the same accuracy levels as the 19 key classes, they might be based on divisions which some users would wish to refine. The full list of 25 classes would not necessarily show on all maps and in data summaries; but they would be consistently available for all of Britain. Ultimately, there will be the subclass data, unvalidated as subclasses, not entirely consistent, not used for normal display or data summaries, but resident in archive for specialist consultation.

FIELD RECONNAISSANCE

The procedure of classification is based on an extrapolation from sample statistics derived from examples of 'training data' defined on the image analysis system. These training areas are selected to be typical examples of their class. They are based on knowledge derived, in a field-reconnaissance survey.

Figure 7

NUMBERING AND NOMENCLATURE FOR CLASSES IN THE LAND COVER OF BRITAIN

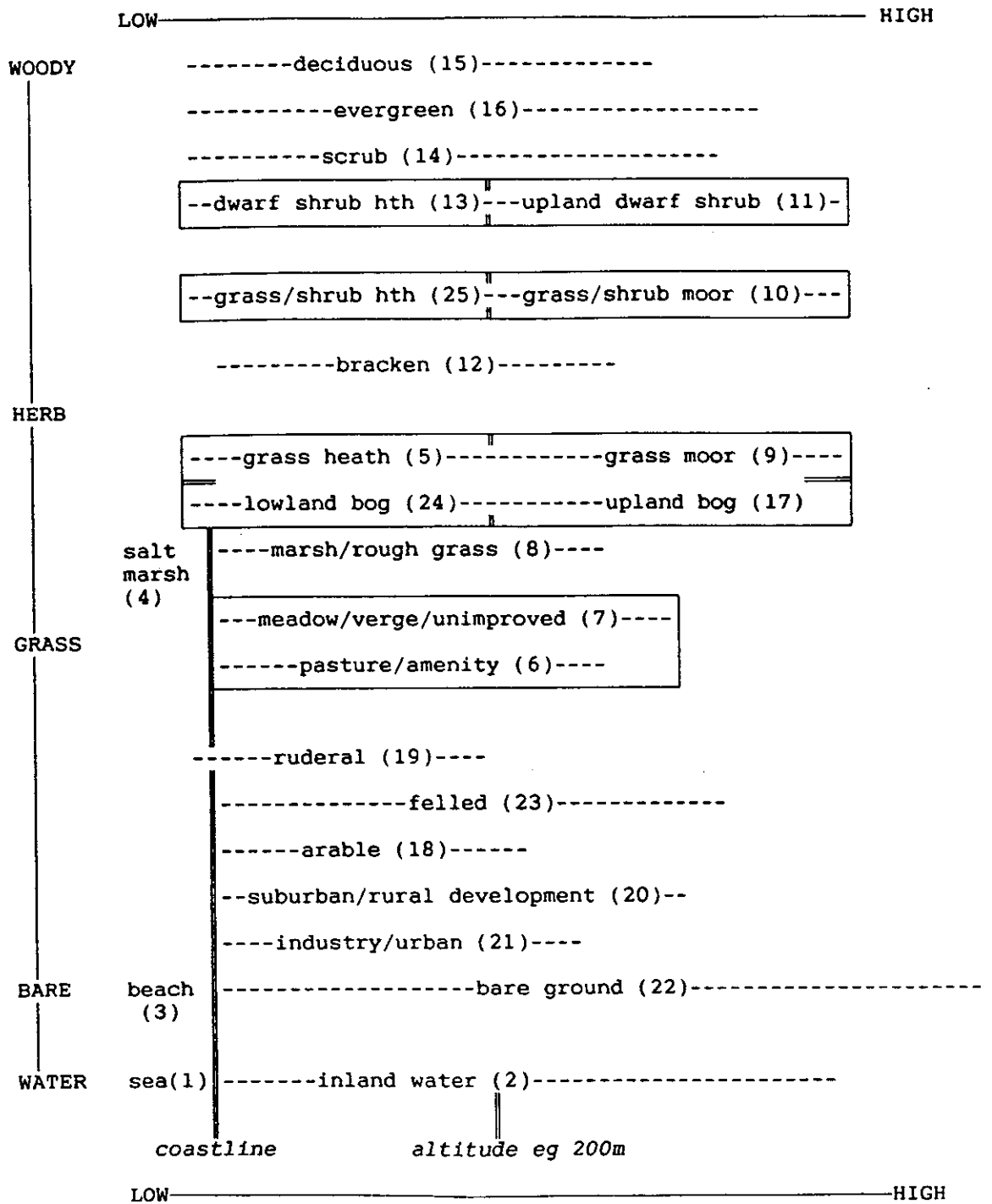

The land cover classification used in the Landsat mapping of Britain.

The collection of ground data for training involved, at first, a preliminary classification based on visual interpretation of imagery, plus existing knowledge (including maps etc.) This identified unclassified areas on the classmap, and showed gaps in our knowledge of good training areas, thus directing our field reconnaissance. However, the practice of initial classification was found to be counter-productive in areas where our existing knowledge was scant. Under such circumstances, poorly interpreted training areas often needed replacement once field-reconnaissance had identified good examples of pure subclasses. Consequently, field reconnaissance now precedes any training.

Photographic copies of the images are made using the usual band-combination (winter near-IR, summer mid-IR and red bands to the red, green and blue display channels respectively (Fuller & Parsell 1990)). A route is planned which encompasses as much as possible of the diversity of the landscape to be covered. The route is photographed and printed at around 1:60000 scale. Photographs are annotated whilst following the route in a vehicle, but with frequent stops to examine species-contents and any other factors which might affect the exact classification of an area. Typically, field reconnaissance identifies the cover in about 1200 land/water parcels per Landsat scene. A sample of such information is then used for definition of subclasses and training areas. Field reconnaissance has been completed for all stock-scenes, except for the south-coast fringe. This represents about three-quarters of all intended field reconnaissance (Figure 5).

TRAINING THE MAXIMUM LIKELIHOOD CLASSIFIER

Training the image classifier involves outlining groups of pixels which are representative of the particular classes or subclasses intended for classification. As a minimum we would expect to define one training class for all of the 25 target-classes to be found on the scene under analysis. In practice most classes require further subdivision, whenever distinct variants are seen. Arable land, for example, may show many subclasses representing the specific crops: they would probably need even further subdivision into spring and winter-sown examples. In hilly areas it is usually necessary to identify strongly sunlit and darkly shaded variants of a subclass. Some classes may require 5-10 subclasses, others may only need one. Overall, 70-80 subclasses represents a typical number for most scenes.

Extrapolation finds all other pixels in the scene with the same spectral characteristics as the subclasses used in training. The procedure in use is the maximum likelihood classifier (Schowengerdt 1983). The classifier allocates each pixel to its nearest subclass (in statistical terms) or rejects pixels if dissimilar to all available subclasses. By defining a rejection threshold, it is possible to reject more or less of the scene. Here we have defined all but the very rarest of subclasses so the threshold is varied in order to classify 99% or more of land/water parcels, though with odd minor mist- or cloud-covered parts rejected.

If a class is over-extensive after classification, and if examination of training areas identifies two or more variants of the class,

subdivision will usually rectify the problem. In effect, it tightens the standard deviations, such that the class becomes statistically less variable, thereby capturing less 'stray' pixels in the scene. In other circumstances, a cover type may be under-represented in a classification, and examination of unclassified parts of the scene, or overclassified parts of other classes, identifies a colour-subclass not used in training. Here it would be necessary to add examples of such colours, usually as samples of a new subclass. The process of training and classification is an iterative one, relying on preliminary classification, inspection of results, edition or addition of training subclasses, then reclassification, towards a final cover map.

Ideally, this iterative procedure would incorporate objective measures of whether subclasses and the selected training areas fulfilled the statistical assumptions of the classifier. In practice, the software is not in place to adequately test this assumption. Hence, the procedures for image classification are partly subjective, with some element of art and science. However, this is also true of airphoto-interpretation, or plant species identification or many other visual interpretations made in science. We overcome the risk of gross error by building checks into the outcome of classifications, in particular, by scoring the correspondence between the cover map and the field reconnaissance data. Finally, the subclasses and their training areas are amended, as necessary, using check-areas as additional training data, to correct consistent discrepancies of omission and commission. Thus a final classification is achieved by an iterative procedure of training, classification and retraining, until results are assessed to be satisfactory.

The IIS has a maximum likelihood classifier implemented in a particularly fast form using the pipeline processors of the M75 (Settle & Briggs 1987). It is thanks to this software that it is feasible to undertake this massive exercise. Even then a classification takes 3-6 hours of processing time. The CPU-based procedure, which is a little more sophisticated, would probably take 30 hours to run; clearly this would preclude the use of the iterative approach, as defined above. Training and classification has been completed for scenes covering some 80% of England, 30% of Wales and 10% of Scotland (Figure 8).

KNOWLEDGE-BASED CORRECTIONS

Some classes cannot always be reliably separated purely on the basis of spectral differences. Contextual information, either drawn from outside sources, or derived from the data, can help correct any errors.

Coastal masking

Urban and suburban areas are often confused with beaches. Sea and inland water bodies are not very different in spectral signatures. Saltmarshes may be confused with arable crops. By defining a coastline, it is possible to impose the rule that terrestrial habitats are only found inland of the line, maritime habitats to seawards. Most seminatural habitats can fall in either area (wooded cliffs, wetland dune slacks, grazed upper saltmarshes are options). The definition of the coastline is therefore generally

Figure 8

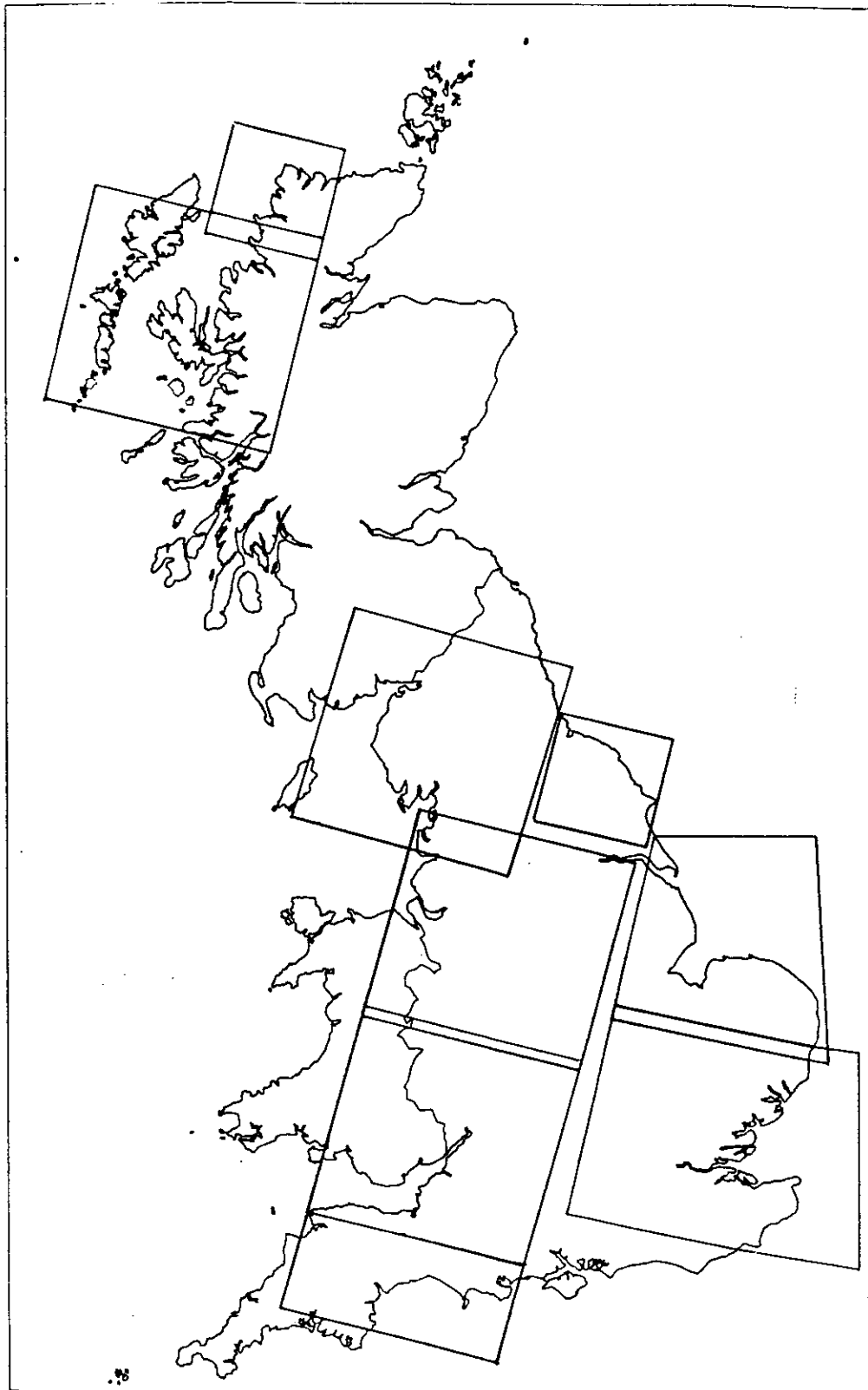

Areas classified, December 1991.

straightforward, taking a line through any seminatural vegetation which separates the shoreline from the arable and urban areas. Only where these meet the shore is it necessary to define an exact line. The definition is done interactively on the image processor.

Moorland masking

The problems of separating upland and lowland cover-types have been mentioned above. Generally, the separations can be made spectrally, with about 70% success. Thus, we can filter out small pockets of misclassified lowland habitat, using a knowledge that it is surrounded by extensive upland areas. In order to generalise, the cover map is reduced to one-fifth scale, and cover types are reduced to two, upland and lowland types. A 9 x 9 majority filter is used to remove outliers of upland (ie less than 41 pixels, equivalent to 1600 ha at full resolution). A 'maximum-filter' is then used to grow the remaining upland region, to fill holes: a 9 x 9 kernel window means that upland regions will grow by about 8 pixels (at one-fifth reduction this equivalent to 1000 m) all-round, therefore filling any lowland parcels of 2000 m across or less, and extending the upland mask 1000 m outwards. The new, dilated mask is then enlarged x5 back to full size, and smoothed using a 5 x 5 majority filter to smooth the 'boxy' outline of the upland area. Clearly, this procedure is not without significant problems: it can grow the upland region into lowlands that were correctly identified; and it eliminates small areas of upland which had been correctly mapped. Nonetheless, it has a beneficial effect on classification accuracy for the vast majority of upland moorlands and lowland heaths. It also has the advantage that it relies on a knowledge of majority-cover, rather than some arbitrary altitude mask. In the consultative exercise on the cover types to be used, several people commented that moorlands came down towards sea level in north-west Scotland whereas in eastern England, in the North York Moors, the moorland might be above 300 m. This masking procedure allows for such regional variations. Individual users will need to make their own judgement as to whether they wish to use the distinctions or re-aggregate the upland-lowland classes, and use alternative contextual information (eg altitude masks) to make the distinction.

Urban/suburban masking

The complex mosaics of vegetation and built-up land in urban areas can suffer from minor misregistrations between summer and winter images, which give pixels the same characteristic as arable land, namely a bare appearance on one date, vegetated the other: where urban trees overhang tarmac and concrete, the same can arise: these lead to some patches of vegetation in urban areas being misclassified as arable areas. An urban mask is made using urban and suburban pixels. Holes in the mask are then filled using a 5 x 5 kernel majority-filter. The resulting mask is then used to correct urban arable areas. Any such patches which fall under the mask are changed to suburban pixels. Other classes such as deciduous and coniferous trees, water bodies grasslands are allowed to remain as they are normal features of urban environments.

Local interactive corrections

Sometimes odd clouds obscure a small part of the summer or winter image; pockets of haze might also cause very occasional difficulties.

In such cases, it is possible to classify using just the one good date, cut out the area covered with haze, cloud or shadow and insert a patch from the single-date cover map.

In some areas, odd cover types (eg peat cuttings), perhaps too small to train as subclasses, get misclassified; in such circumstances, it is possible to take out a 'tile' of the cover map, renumber the cover value in a locality to the correct value, and place the corrected 'tile' back into the cover map.

CHECKING MAPS AGAINST FIELD RECONNAISSANCE DATA

Field reconnaissance data are used to score the success or otherwise, field by field, of the cover maps. Each land or water parcel annotated on the field reconnaissance photographs is inspected on the cover map. The cover is taken to be that shown by the majority of pixels in the parcel; in other words discontinuities, whether real or artifacts, are ignored. A confusion matrix is constructed from the scores for all land/water parcels. Table 3 gives results for the combined scores of images 201-023, 201-024, 202-022, 203-023 and 203-024 (see Figure 5).

Results show that 5720 land/water parcels, recorded in the field, were scored on the cover maps from these scenes. Comparing direct correspondence shows 75.3% agreement between field and Landsat maps. However, this figure is based on separations which include distinctions between pastures and meadows. Such distinctions represent a potentially transient situation, are only possible in the field for perhaps half of all fields given a single date visit, and are only intended as a guide (see class descriptions). Aggregation of the two classes gives 84.1% correspondence. The distinction between dwarf shrub moor and grass/shrub moor represents a division of a continuum which is open to subjectivity, and confusions are likely to be due to discrepancies in field recording. The same applies in separating urban and suburban areas. Discounting such differences gives a concordance of 85.1%. Such a figure agrees with levels of accuracy achieved in the pilot studies on which this project was based (Fuller *et al.* 1989, Fuller & Parsell 1990). The figure matches the target level of accuracy defined in the project plan. However, it should be realised that the sample of 5720 land/water parcels was not necessarily representative of the full study area, indeed it was chosen to highlight unusual areas. Such a bias towards cover types which are rare or unusual almost certainly obscures the greater levels of accuracy achieved in classifying the more commonplace cover types. Hence the indication of an 85% 'accuracy' in classification can only be taken as a guide.

Full validation is taking place against a stratified random sample, using the 1 km field-survey squares of Countryside 1990.

VALIDATION AGAINST DIGITISED 1 KM FIELD SURVEY SQUARES

The final validation phase will use digitised map data of the 1 km squares recorded in the sample-based field survey of Countryside 1990.

Following discussions and field meetings between the field and Landsat survey coordinators, it has been agreed that the field

Table 3. A confusion matrix showing correspondence (%) between field-cover (down) and map-cover (across), based on scoring 5720 land/water parcels. Values representing concordance between field and map-classes are highlighted in bold text.

	0	1	2	3	4	5	6	7	8	9	10	11	12	13	14	15	16	17	18	19	20	21	22	23	
	unclass sea	Inland water	Inland water	beach/flats	salt-marsh	grass heath	pasture meadow	rough grass	rough grass	upland grass	grass heather d.shrub	upland grass/heather d.shrub	bracken heath	heather scrub	decid. woods	conif. woods	ruderal weeds	ruderal weeds	suburb	suburb	urban	bare ground	felled forest		
Sea																									
Inland water			1.35																						
Beach/flats				0.03																					
Saltmarsh					0.21																				
Grass-heath						0.17																			
Pasture	0.03						16.26	7.13	0.33	0.86	0.12	0.03	0.03	0.09	0.02	0.02	0.03	0.03	0.03	0.03	0.02	0.02	0.02	0.02	
Meadow	0.02						1.75	3.53	0.24	0.07				0.03				0.09	0.02	0.02	0.02	0.02			
Rough grass	0.03				0.05	0.07	0.03	0.09	1.19	0.09	0.02			0.09	0.02			0.09							
Upland grass							0.17	0.05	1.03	0.02	0.02	0.02													
Dwarf shrub/grass										0.91															
Dwarf shrub							0.03	0.07		0.21	0.17	1.26	0.14		0.02						0.02				
Bracken							0.07	0.07	0.05	0.03	0.02	2.59	0.03	0.03	0.16			0.02	0.02	0.02	0.02				
Heather Heath									0.05				0.44	0.02	0.02										
Scrub	0.03						0.02	0.16	0.19	0.02	0.07	0.07	0.03	0.02	0.59	0.31		0.09	0.09	0.10					
Deciduous							0.02	0.02	0.10	0.05		0.05	0.44	0.02	0.10	9.51	0.40	0.19	0.19	0.02					
Coniferous	0.07								0.02	0.03	0.05	0.05		0.03	0.03	1.59	6.03	0.09	0.09						
Arable	0.47		0.02		0.31		0.17	1.01	0.21							0.02		22.73	0.16	1.19	0.23	0.35	0.05	0.05	
Ruderal weeds	0.02																	0.12	0.12	0.05					
Suburban	0.02						0.03	0.03	0.02	0.02								0.17	0.02	5.38	0.35	0.05	0.02	0.02	
Urban	0.03																	0.23	0.23	0.47	1.28	0.40	0.40	2.41	
Bare	0.02																	0.26	0.02	0.09	0.12	0.82		1.33	

survey's 'primary codes' (CSS 1990) will provide an suitable basis for comparison. The only exceptions are, first, where secondary codes (on species and their cover) are required to subdivide the broad agricultural grassland class of the field survey, second, where field bracken-cover is needed to compare with Landsat bracken areas. Otherwise, the primary codes give a subdivision, equal to or greater than that of the Landsat map, and thus provide appropriate comparisons.

Developing an optimal method for comparison of squares is vital to satisfactory progress with a procedure which is to be repeated 500+ times. After this development phase, the job becomes a repetitive procedure, undertaken as batch-processing, with limited interactive work.

The Merlewood data arrives in ArcInfo export format as four 'coverages' based on the field recording sheets for physiographic features, agriculture/natural vegetation, forestry/woodland and buildings/structures/communications with a separate text file for polygon seed points. A conversion programme changes the data from ArcInfo to Laserscan format. The four different coverage files are then combined into one and given national grid local origin coordinates and a map scale, as all this information is stripped from the file during the transfer process. The file is then ready for the 'clean up' processes, to remove duplicate lines and lines that do not join up properly. When this is complete, the file can be run through an initial checking stage of the polygon forming program. The next stage is to generate a seed point file from the text file that arrives from Merlewood. This is done by running a BASIC program to convert the text file into a Laserscan map file.

Once the first two stages are complete the polygon forming programme can be run, and then the resulting file is rasterised. At present the file is being rasterised at 5 m resolution and 25 m resolution, the 5 m resolution file then being subsampled to produce a 25 m pixel to give two slightly different output files. The next process is to convert the land cover file from IIS format into Laserscan raster format so that we have the two products in the same raster format. Once both sets of data are in Laserscan raster format a programme is run to convert them into text format for validating using a FORTRAN programme.

We have also been experimenting with the files in raster format in Laserscan 'Horizon' to view the results on the system. Unfortunately it has not been possible to actually count the number of pixels of the same value that are coincident on the two products and so are 'correct', or the number of pixels that are 'incorrect', as the coincident values (based on Landsat cover-types and field feature-codes) are different on the two products. For statistical analysis of the data it is more convenient to use the FORTRAN program.

BUILDING THE MOSAIC OF FULL GB LAND COVER

Land cover maps of scenes 201-023 and 201-024 have been mosaicked together for demonstration purposes. Building a mosaic of full GB land cover has continued, with the data stored as 100 km tiles

Figure 9

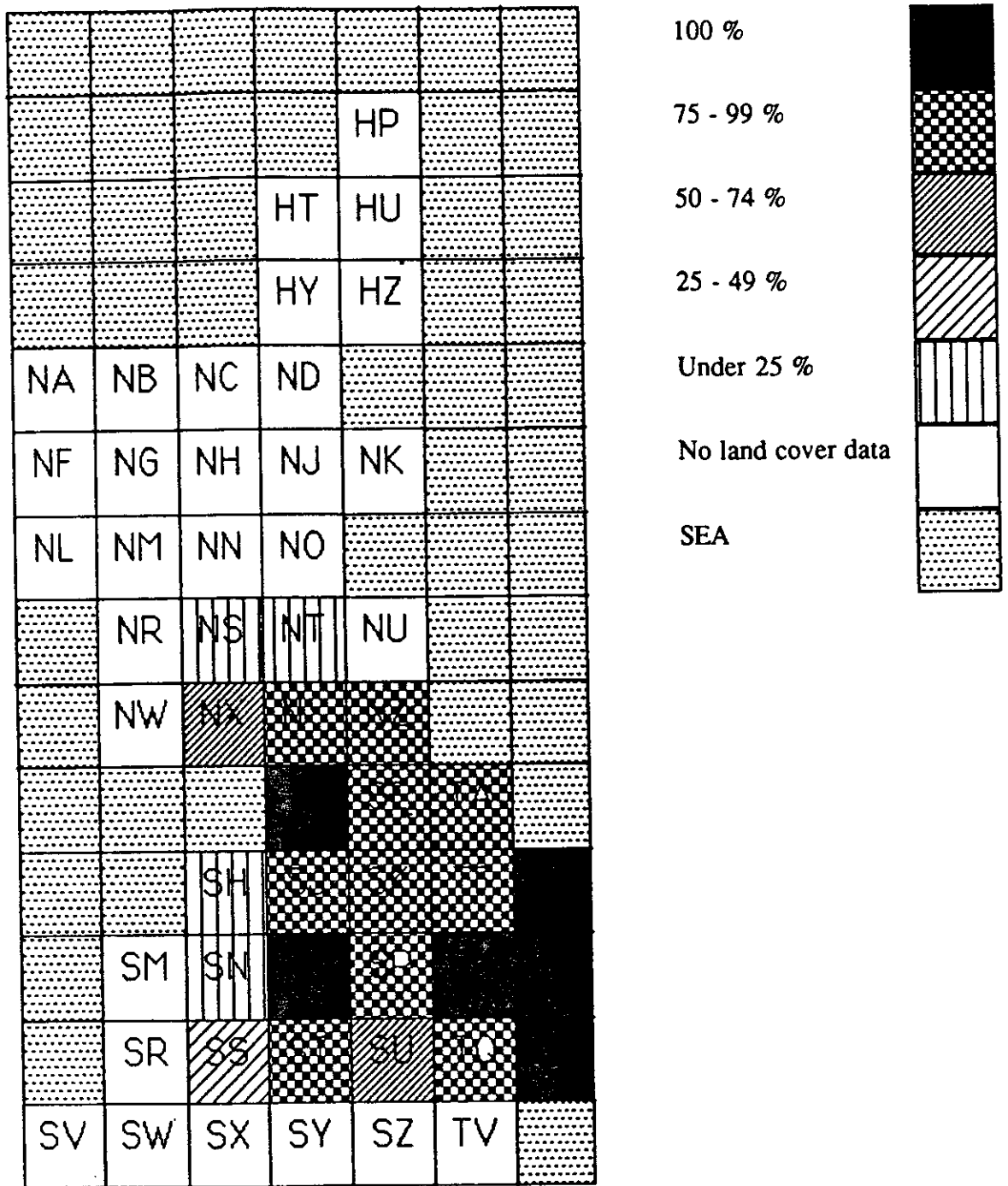

Ordnance Survey 100 km grid squares filled or part-filled by completed cover-maps.

(see Figure 9). These are made as 'jigsaws' from the appropriate sections of each scene. As a scene-classification is completed, the sections are 'cut out' and stored in their 100 km tile. Building the mosaic will simply involve butt-joining the tiles. Merging will be used to give maps and data covering all of Great Britain.

HARD COPY MAP PRODUCTION

Hard copy production will provide outputs at various scales and resolutions. Full resolution maps of small areas have been produced routinely and demonstrated to various end-users. Figures 10-13 give examples of output from a thermal wax printer, showing parts of London, the Norfolk Broads, the North York Moors and Ardnamurchan.

The quality of the classification is immediately apparent from examination of these plots. In London (Figure 10) it is possible to see the urban centre (dark grey) giving way to suburban areas (light grey) and the grass areas (green) of the London Parks such as Hyde Park (top left) with the Serpentine (blue); note the fine detail, for example the 'herring-bone' of suburban streets or the bridges (grey) across the Thames.

The Broads map (Figure 11) clearly shows the semi-natural vegetation of river valleys; for example the River Bure from Wroxham (grey - top left) is lined by wet 'carr' woodlands (pink) with extensive reed beds (yellow); the River Ant (top, centre) also has extensive reed beds which give way to grasslands (green) where the Ant and Bure meet; by the time the River Thurne (top right) meets these Rivers, grasslands are punctuated by extensive areas of drained land used for arable farming (dark brown). The surrounding landscape is also predominantly arable.

The North York Moors map (Figure 12) shows the heather moorlands (mauve), with the regular pattern of burnt moor (dark green) comprising mixed grass and regenerating heather, so favoured by grouse. Note the steep valley sides with bracken (orange), dropping down to the valley floor of pastures and meadows (green).

The Ardnamurchan map (Figure 13) shows upland grass-heather moor (dark green) with bogs (khaki) and moorland grassland (light tan) in a distinctive ring of hills associated with the underlying geology.

Thermal wax plots cannot match the quality provided by film-writing which produces a negative for photographic printing. A full resolution 8 inch by 10 inch SPECTRASCAN plot has been made by the film-writer at the National Remote Sensing Centre. The image covers South-east England. Large format (c. 1 metre) prints have been displayed at the meeting on the 'Land Use Change: Causes and Consequences', Newcastle; at the Royal Agricultural Show, Stoneleigh; and at the Paris Air Show. The DTI already has a large transparent copy for display-purposes.

Hard copy production has now provided a SPECTRASCAN negative of the north-west England scene as a summer-winter composite. This very striking image will take enlargement to about 1.5 m square before the film grain starts to show. The negative is available to produce

Figure 10

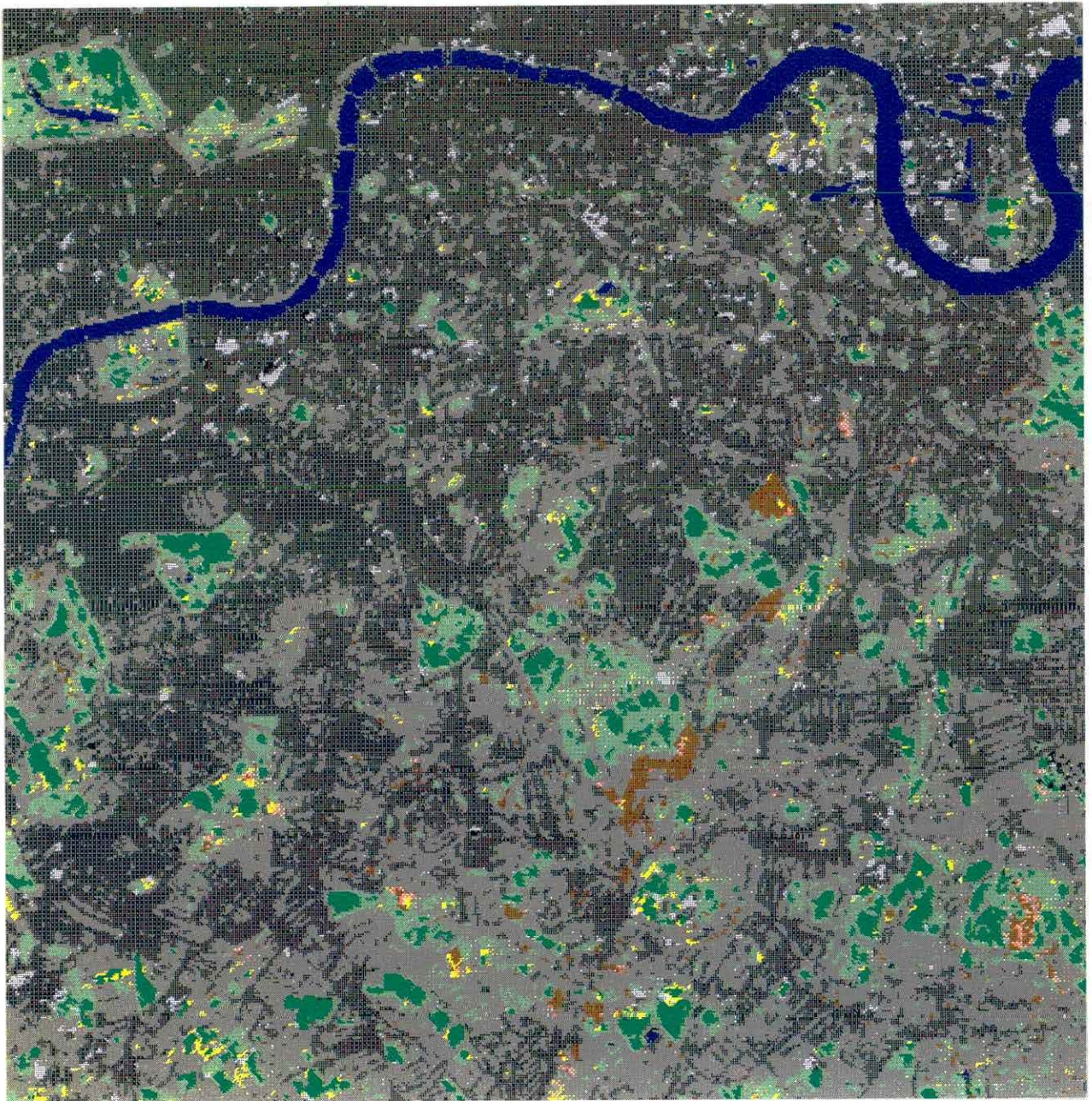

A 12.8 km x 12.8 km section of the land cover map for central London: it is possible to see the urban centre (dark grey) giving way to suburban areas (light grey) and the grass areas (green) of the London Parks such as Hyde Park (top left) with the Serpentine (blue); note the fine detail, for example the 'herring-bone' of suburban streets or the bridges (grey) across the Thames.

Figure 11

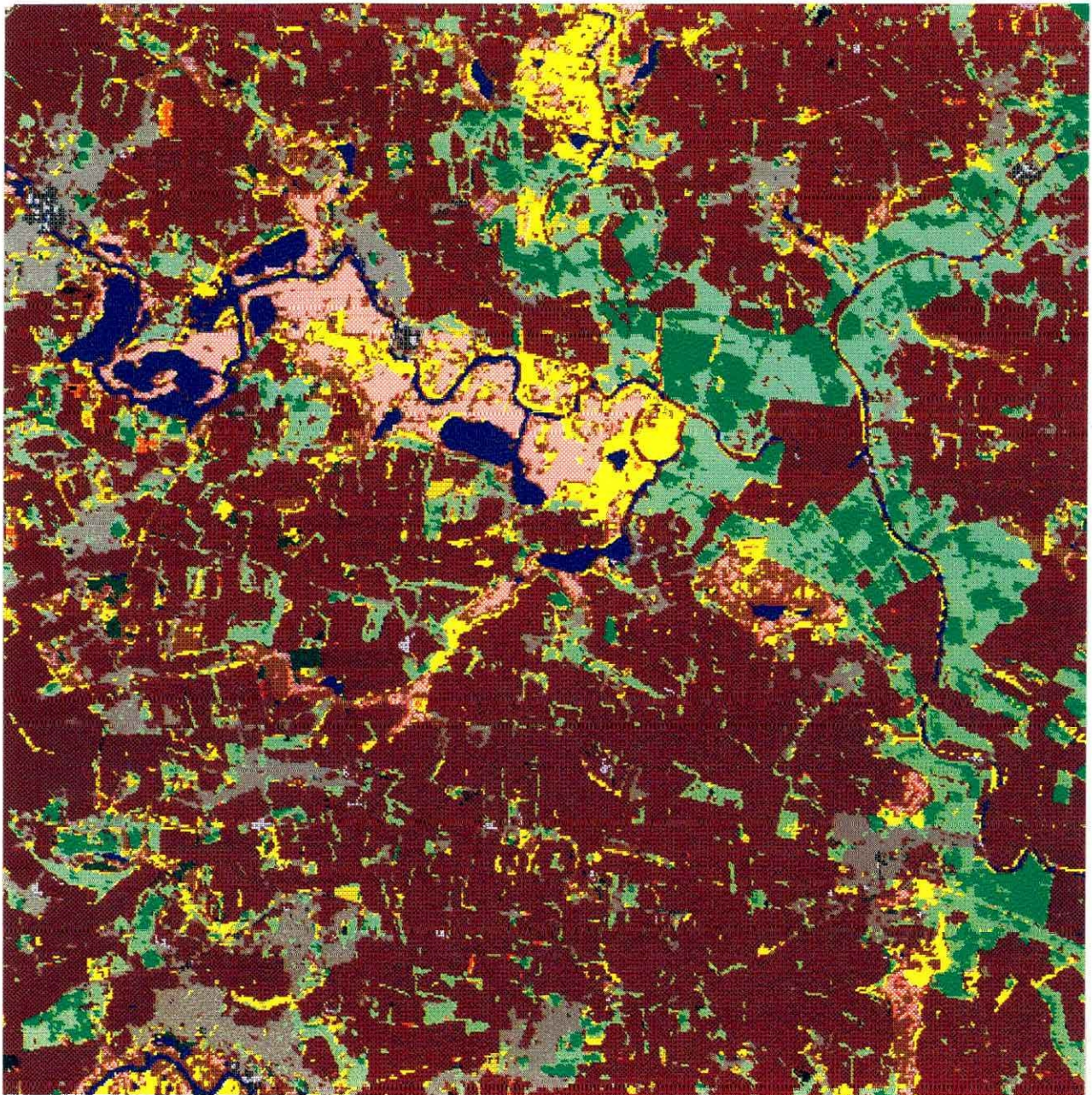

A 12.8 km x 12.8 km section of the land cover map for the Norfolk Broads: it clearly shows the semi-natural vegetation of river valleys; for example the River Bure from Wroxham (grey - top left) is lined by wet 'carr' woodlands (pink) with extensive reed beds (yellow); the River Ant (top, centre) also has extensive reed beds which give way to grasslands (green) where the Ant and Bure meet; by the time the River Thurne (top right) meets these Rivers, grasslands are punctuated by extensive areas of drained land used for arable farming (dark brown). The surrounding landscape is also predominantly arable.

Figure 12

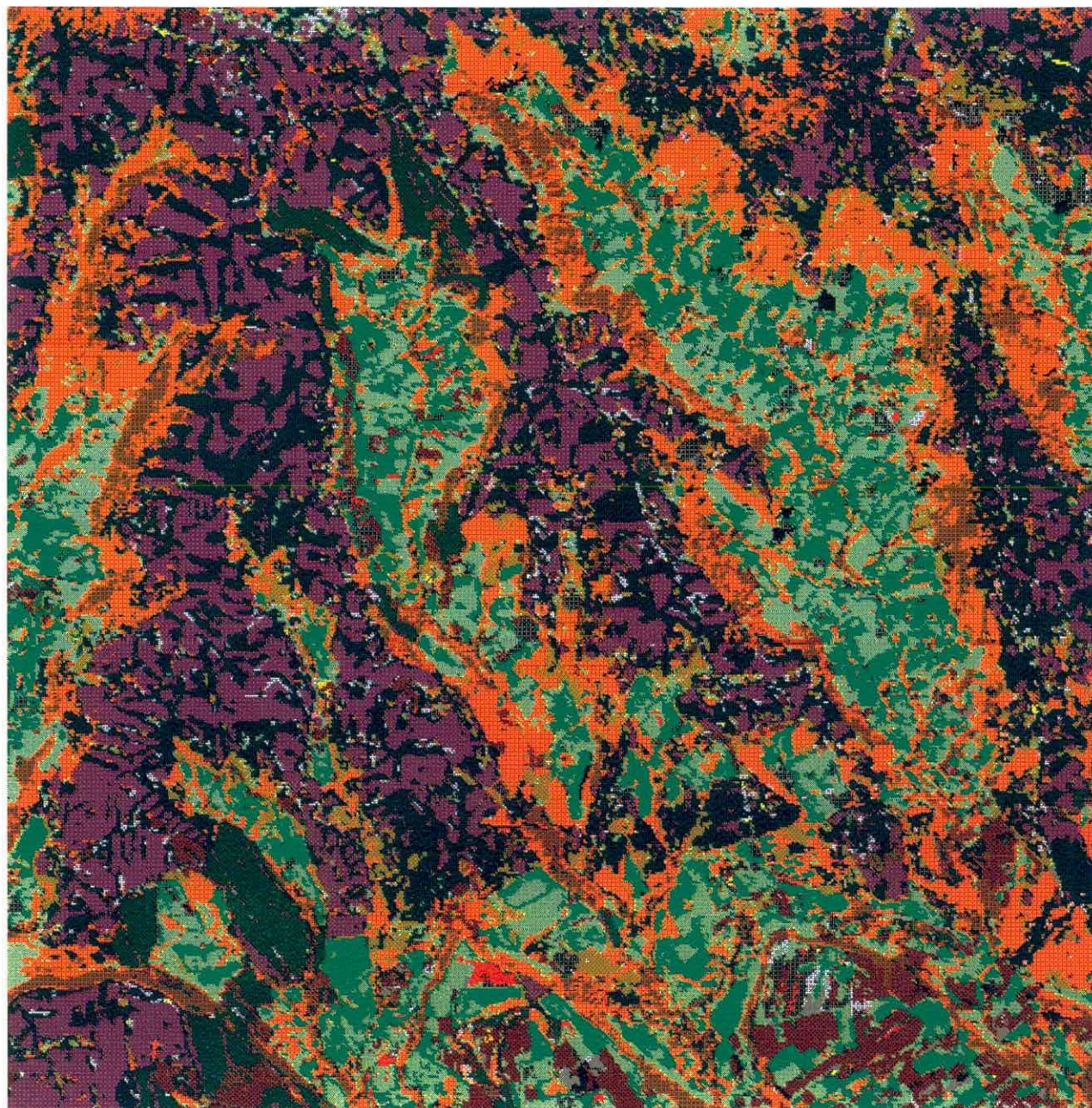

A 12.8 km x 12.8 km section of the land cover map for the North Yorks Moors; it shows the heather moorlands (mauve), with the regular patterns of burn moorland (dark green) comprising mixed grass and the regenerating heather which is so important to grouse. Note the steep valley sides with bracken (orange), dropping down to the valley floor of pastures and meadows (green).

Figure 13

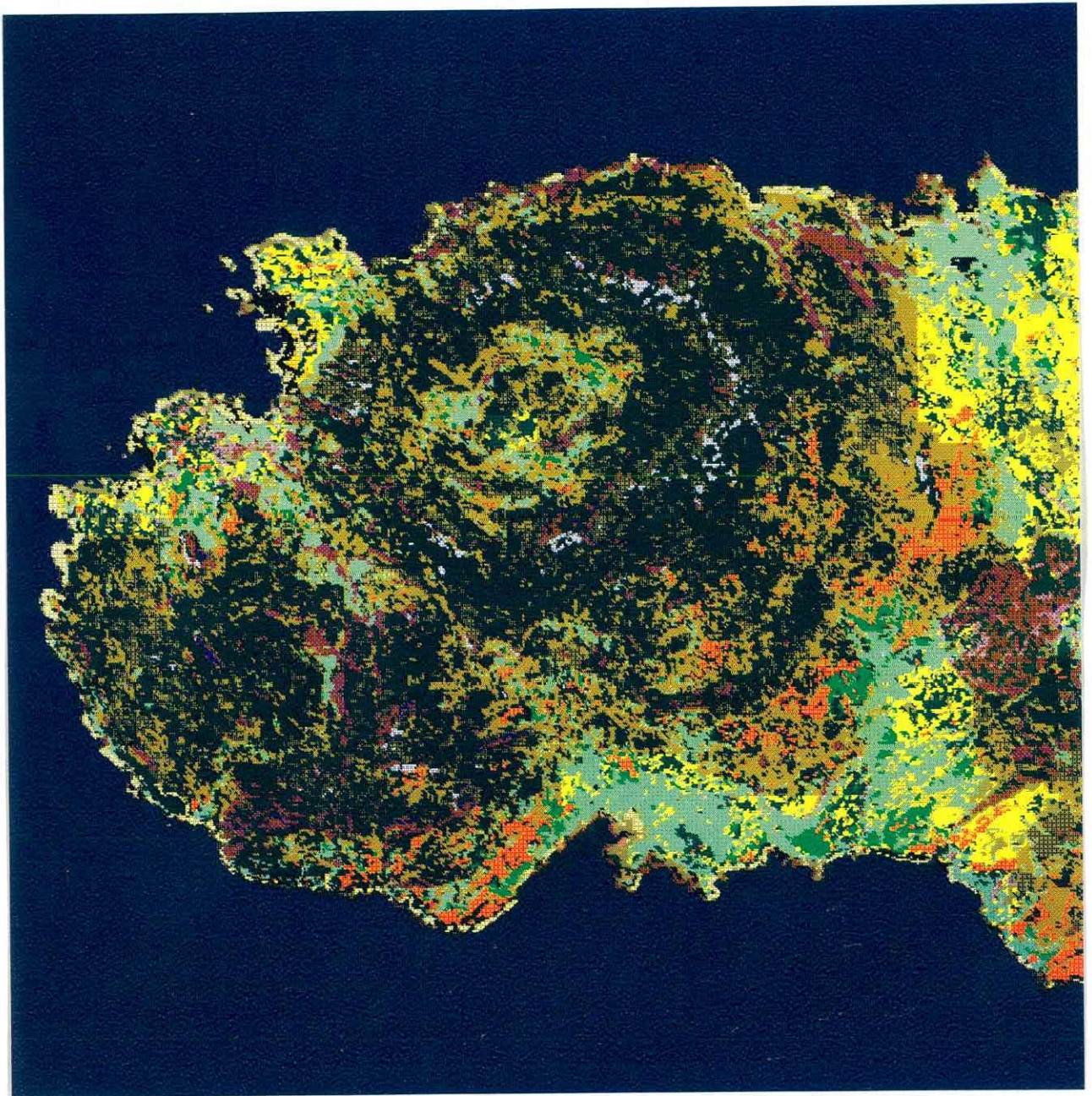

A 12.8 km x 12.8 km section of the land cover map Ardnamurchan: it shows upland grass-heather moor (dark green) with bogs (khaki) and moorland grassland (light tan) in a distinctive ring of hills associated with the underlying geology. Note the bracken (orange) of lower slopes giving way to grasslands (green) in the valleys, with a shoreline beaches and rocks (sand coloured).

display prints for use with cover maps. Future outputs require arationalisation of colours to reflect the similarities and differences between habitats and to maximise distinctions between key classes. New versions of the colour maps will be produced during the coming winter.

GIS DEMONSTRATION

GIS demonstration work has started with the export of sample areas from the IIS image analysis system to the Laserscan GIS, and this has included early trials of raster-to-vector conversion. These procedures have since been used on a 75 km x 50 km test area centred on the Thames estuary. This was successfully converted from raster to vector data. Such conversion highlighted the problems of dealing with large databases, such as the cover map will provide. This relatively small area, one-sixtieth of all Britain, contained 80000 polygons. There is no commercial GIS which could realistically handle such detailed vector information for all of Britain. Simplification, by filtering out all small parcels, would be possible, but risks throwing away useful information. Simplification was a necessary part of conventional cartography when a cartographer had to individually draw and classify every parcel. It is not a necessary part of raster image classification. So, unless it can be shown that the fine detail is 'noise' rather than data, the detail should not be lost for mere convenience. It would be far better to examine ways of storing and accessing raster data, converting to vector only where necessary, perhaps temporarily. The Laserscan system may have such potential, and methods will be tested during the continuing GIS demonstration phase of this project.

An additional GIS requirement for DoE and other users, and especially for analyses in conjunction with the field survey, is the summary of data at 1 km and other grid sizes. We have adapted existing software which can now provide proportional cover, per grid cell, of all land cover types in each cell. So, for example, Norfolk data have been provided to the British Trust for Ornithology, summarised as 23 arrays (for 23 cover types), with score per tetrad (2 km x 2 km square). Such data will be related to common bird census data, also collected in tetrads. Maps will be summarised per kilometre square for later use with land class maps and summary statistics.

The data are also being summarised, as 1 km grid data, recording broad distributions of landscape components in an ORACLE database. This will be used to develop a user-accessible dataset, microcomputer-based, for applications purposes. The data, combined with the ITE field survey summaries, will also improve cover-estimates derived from the latter, and allow sophisticated interrogation of the integrated datasets.

PATTERN ANALYSIS

In the Ecology of Land Use Change ECOLUC project for the DoE, Griffiths and Wooding (1989) outlined methods for analyses of landscape patterns, using data derived from a classification of Landsat images. They employed concepts such as:

1. Patch size, patch frequency.
2. Fragmentation, isolation.

3. Boundary measures.
4. Density/diversity.

It is intended to develop this work using the more extensive data of the current project. First, this will require development of functions in the Laserscan Horizon GIS that mimic the types of pattern analyses already achieved and described by Griffiths and Wooding. Their work was essentially raster-based. There is limited value in converting these techniques to Laserscan Horizon if there are advantages in continuing to use a raster-based environment. However, it has been noted that a vector-based GIS is operationally simpler for assessing the nature of polygon boundaries (Johnston & Bonde, 1989) and boundary data are especially important in landscape terms, especially in the arable landscape. Therefore, effort will be devoted to making some of these 'raster techniques' operational within the Horizon GIS, and applied to the land cover map.

The following sections aim to describe, briefly, how the measures of pattern might be applied:

Patch size, patch frequency

It is proposed to use routines developed to classify individual land cover types into a range of parcel sizes to then produce size-frequency distribution statistics. These techniques have been developed in the raster-based software of Horizon.

Boundary measures

It will be possible to calculate the length of boundaries between contiguous cover types. Thus we might make measurements of the degree of association between cover types e.g the length of bracken, contiguous with heather moorland, hence the potential front for bracken-invasion of moorland. Preparatory work has begun with the vector-conversion of a test area of land cover data. This vector-conversion has been done both with and without interpolation. The boundaries made without interpolation will not degrade the accuracy of boundary measurement at all but will not take advantage of the visual improvement offered by vector graphics. However at smaller scales the 'stepping' effect of raster based boundaries is not visible.

Fragmentation, isolation

The pattern analysis will examine the perimeter/area ratio of features to measure of fragmentation. This would be possible for individual cover types or for land parcels generally, irrespective of type. Measurements of parcel and perimeter lengths are much more accurate in vector form; however in this case, the vectors we are measuring will have been derived from raster pixels using raster/vector transfer or some form of raster/vector overlaying on the Horizon screen. In these circumstances it is probable that vector measurements will actually be less accurate than the original raster equivalent. This type of problem will need to be quantified. Where use is made of alternative vector data, such as the Bartholomews topographic data, in conjunction with the raster land cover data, then accuracies will probably be improved compared with use of raster values alone.

Measures of isolation will use vector buffer zones applied to selected classes. For instance applying a 200 m zone to identify how many woodlands are isolated from neighbouring woodlands by more than this amount; also, to see how much of some other cover-type, such as grassland, is within 200 metres of woodland. Various threshold distances could be used.

Density/diversity

Measures of density and diversity are best created and more suitable for vector rather than raster analysis. It is possible to identify and count parcels and to impose a threshold-size, for instance, highlighting the number and distribution of woodlands below a threshold size.

The analyses of pattern will examine cover-information may also draw on data from other sources: for example, it may be of interest to quantify cover types within fixed distances of roads as defined from published maps, to count woodlands on chalk soils or to estimate bracken boundary-lengths above a mapped contour level.

It must be emphasized that the raster capabilities within Horizon are rather limited and do not approach the ability of the IIS. Even where vector data is used there are still some fundamental limitations. For instance whereas it is easy to define regions in vector, such as Cambridgeshire, this is not easily imposed on the raster file that can be displayed simultaneously. Achieving efficient ways of doing raster calculations within specific vector parcels may involve complex software development which begins to move away from standard methodological development towards more fundamental system design. This is a task for the GIS manufacturer who has immediate access to the software design people originally responsible for the system creation. In collaboration with BNSC, LaserScan are developing the 'next generation' GIS. ITE (B K Wyatt & N J Brown) have had detailed discussion with the LaserScan development team. They were made aware of the importance of developing the raster capability within Horizon and, indeed, the new system is being produced for use with raster data as one of their prime objectives. There will be a point within the near future when ITE are likely to receive an early version of this 'new GIS' for user-testing which will open up opportunities for raster-vector integration at levels not routinely available. This will in fact be a vital step forward if the cover map is to be useable, routinely, extensively, at full resolution, and for any part of Britain.

APPLICATIONS - DEMONSTRATOR PROJECTS

There are a number of pilot projects under way or advanced in their planning which will demonstrate the use of the cover data in studies of the environment. These include:

- analyses of land cover and common bird census-data for Norfolk (with British Trust for Ornithology)
- comparisons with Macaulay Land Use Research Institute, airphoto-based, Land Cover of Scotland

- use of land cover data in the Newcastle University Land Use Project on river catchments
- comparisons with Ministry of Agriculture, airphoto-based, cover maps of Environmentally Sensitive Areas
- Terrestrial Initiative in Global Environmental Research, proposals to estimate carbon pools (with Institute of Hydrology (IH))
- use of cover data in IH 'Water Information System'
- use of land cover data for Expert System on Pesticide Loading of Waters (with FARMSTAT, IH, Soil Survey Land Research Centre, Water Research Centre)
- ITE monitoring of the land used by radio-tagged birds
- mapping habitat sensitivity (ITE for Her Majesty's Inspectorate of Pollution)
- heath and moor survey (DoE, MAFF)

While such uses remain as pilot-studies, it is possible to undertake such commitments without significant impact on the production phase of the work. Insofar as these studies will be reported as GIS demonstrators (see above) they also fit with the general theme of the project.

FORWARD LOOK FOR 1992

The aims in 1992 will be to adhere closely to the planned schedule of activities as given in the original project outline (see Figure 6 of this report). Specifically, this should involve completing the classification of all scenes. Most of the validation will be completed, and data will be extracted as 100 km squares, ready for final construction of the full national land cover map. GIS demonstration and pattern analyses will continue. Some limited rescheduling might involve interchanging elements of the classification, validation and GIS work, for logistical reasons of staff and equipment availability. However, work continues towards a completion of the present schedule of activities in early 1993.

CONCLUSIONS

The methods for mapping the land cover of Great Britain have been developed, tried and tested such that each stage of the work is mostly routine. Procedures for validation and GIS integration have been firmly established though further testing is required. However, every step involved in the project has now been tested and feasibility has been demonstrated. Figures 5 and 6 indicate that the timetable for the project is realistic. Now that the early development phase is completed, the rate of production matches original intentions. Rescheduling has sometimes been necessary to take best advantage of seasons for field work, image availability, software developments etc. However, on balance, the project is going according to plan: slippages are counter-balanced by advances elsewhere. Perhaps most in doubt, at the start, was the availability of images; this no longer poses a problem. Also questioned was the difficulty of transferring the techniques developed mostly in lowlands to the upland situation. We have now successfully classified several areas around 1000 m in South Wales, the Lake District and Western Scotland, with no particular difficulties. The classification scheme has been tested sufficiently that it can undoubtedly be applied throughout all of Britain. The quality of the product is self-evident in the maps which have been demonstrated. The initial field-checks indicate that the general level of accuracy is on target. Full validation will hopefully confirm this.

GIS demonstrators have started ahead of schedule, and initial stages in the definition of patterns for analysis are in progress. More importantly, demonstrations in the applications of the data are also well advanced with many and varied studies. User-interest is growing very quickly.

REFERENCES

- Barr, C.J. 1990. Mapping the changing face of Britain. *Geographical Magazine*, 62, 44-47.
- Bunce, R.G.H. & Heal, O.W. 1984. Landscape evaluation and the impact of changing land use on the rural environment: the problems and an approach. In: *Planning and ecology*, edited by R.D. Roberts & T.M. Roberts. London: Chapman & Hall.
- Coleman, A. & Maggs, K.R.A. 1965. *Land use survey handbook: an explanation of the second land use survey of Britain on the scale of 1:25000*. Ramsgate, Second land use survey publication.
- CSS, 1990. *Countryside 1990: field handbook*, unpublished.
- Fuller, R.M., Parsell R.J., Oliver, M. & Wyatt, G. 1989a. Visual and computer classifications of remotely-sensed images. A case study of grasslands in Cambridgeshire. *International Journal of Remote Sensing International Journal of Remote Sensing*, 10, 193-210.
- Fuller, R.M., Jones, A.J., & Wyatt, B.K. 1989b. Remote sensing for ecological research: problems and possible solutions. In: *Remote sensing for operational applications; 15th annual conference of the Remote Sensing Society*, 155-164. Reading: RSS.
- Fuller, R.M. & Parsell, R.J. 1990. Classification of TM imagery in the study of land use in lowland Britain: practical considerations for operational use. *International Journal of Remote Sensing*, 11, 1901-1917.
- Griffiths G.H. & Wooding, M.G. 1989. *Use of satellite data for the preparation of land cover maps and statistics. Final report to the Department of the Environment. Volume 1, main report*. NRSC unpublished contract report to DoE.
- Johnston, C.A. & Bode, J. 1989. Quantitative analysis of ecotones using a geographic information system. *Photogrammetric engineering and remote sensing*, 55, 1643-1647.
- Jones, A.J. & Wyatt, B.K. 1989. Remote sensing for monitoring and inventory of protected landscapes; resource management in a less-favoured area. In: *Remote sensing for operational applications: 15th annual conference of the Remote Sensing Society*, 193-200. Reading : RSS.
- Schowengerdt, R.A. 1983. *Techniques for image processing and classification in remote sensing*. London, Academic Press.
- Settle, J.J. & Briggs, S.A. 1987. Fast maximum likelihood classification of remotely-sensed imagery. *International Journal of Remote Sensing*, 8, 723-734.

Stamp, L.D. 1962. *The land of Britain: its use and misuse*, 3rd edn. London, Longmans.

ACKNOWLEDGMENTS

With a project of this size, many people contribute to the end-product. Those people, and even their parent organisations, are too numerous to identify individually. Needless to say, however, the authors are most grateful to all those who have helped in designing this project, identifying images, defining the classes to be used, determining the methods for analyses, inspecting the results, and checking this and other reports. We are especially grateful to the organisations who are funding this work.

LAND COVER CLASSES:

A DESCRIPTION

INTRODUCTION

The following descriptions outline the proposed ITE Landsat-derived classification (Table 1) and define cover-types. The choice of classes is based on personal experience within the ITE Remote Sensing Unit, in surveys made from ground, air and space; it is made after consulting other published surveys, and after personal communication with surveyors. The list represents a compromise between what would be ideal for wide-ranging users, and what is feasible to map, at this scale, from remote sensing. End-users and other surveyors have had the opportunity to comment on, and thereby influence, the final classification - the comments are built into the class descriptions. The numbering of classes reflects the time at which they were added to the classification.

The classes chosen represent an aggregation of many subclasses: for example, wheat, barley and oilseed rape are subclasses of the 'arable' class. These subclasses have been reduced to a short-list of target 'classes' which are considered ecologically meaningful, consistently recognisable from the selected imagery, and realistic in terms of their likely accuracy.

It would be possible to recombine subclasses differently, for example a map of 'graminoids' might be produced by aggregating all grass subclasses, including natural grasslands, agricultural pastures and arable cereals. Very likely, specialist users will require a 'tailor-made' aggregation to meet specific objectives, and this could be done digitally, by reference to the original maps of subclasses. Such users would have to accept that subclasses might not be distinguished consistently (eg not all images were of appropriate date to separate, for example, wheat from barley within the arable class).

The descriptions aim to record any limitations which would prevent further subdivisions to consistent standards. All classes are subject to the provision that they are only mapped if they are above the minimum mappable size, namely two pixels, ie 0.125 ha, though in practice it cannot be said that all 0.125 ha features will be shown - this will depend on how strong the spectral signature of a feature is and how pixels fall with respect to that feature. Minimum consistently mappable area could be 5 ha (Townshend 1983). In practice, the real value is probably between these two extremes, and perhaps nearer to 0.5 to 1 ha: this will only become apparent with quantitative validation, later in the project.

At present, the list distinguishes lowland and upland categories which are very similar, for example lowland heather and upland dwarf shrub. These classes have spectral characteristics which allow their separation, but not with the same level of accuracy as would be available in separating classes with entirely different characteristic species. Regional upland and lowland masks have been created from the cover-classes and coarsely filtered in order to generalise the classification into local and upland types. Some users may feel that other measures of context (eg altitude) are criteria for separation, in which case such separations are best made in a Geographical Information System.

Agricultural grassland subdivisions have been taken further than spectral signatures may justify, because of the importance and extent of agricultural swards (see later). The situation with grasslands is complex: in addition to the interplay of species and altitude, there are extra difficulties imposed by soil-acidity, wetness and, more especially, by complex and changing patterns of grassland-management. In the continua from lowland to upland, from wet to dry, from basic to acid soils and from natural to intensively managed, many classes might be identified. Agriculturalists and conservationists may not necessarily define the same classes, nor would a class be consistent from one agricultural region to another - a rough pasture in SE England might be considered to be good in montane Scotland for example. It is also true that discrete classes may not be spectrally separable, especially where management (eg mowing) obscures the characteristic appearance of the various components. Those classes which are defined here are thought to be ecologically meaningful and separable with good reliability. They are, most importantly, intended to be consistent throughout Britain.

DESCRIPTIONS OF LAND COVER CLASSES USED IN THE MAPPING OF GB

SEA/ESTUARY (class 1)

This category includes all open sea and coastal waters, including estuaries, normally inland to the point where the waterway is constricted to 1 pixel or its continuity is broken by a bridging point. An exception is where waterways open up again into major estuarine features, such as Breydon water near Great Yarmouth or many of the sea lochs on the north-west Scottish coast. The division will be immediately evident by reference to classmaps. It is not intended to accurately show the limit of saline or tidal waters, which may extend much further inland.

Fuller key-name: Sea, coastal waters and estuaries, inland to the first bridging point or barrier.

INLAND WATERS (class 2)

Inland waters include all mappable fresh waters and any estuarine waters which are excluded in the above category. The maps record only those areas which are water-covered on both the winter and summer images. Thus, reservoirs with summer draw-down, or winter-flooded meadows are classified to the summer class (ie bare or grassland in these examples).

Fuller key-name: inland fresh waters and estuarine waters above the first bridging point or barrier.

BEACH/FLATS (class 3)

The beach/flats category includes intertidal mud, silt, sand, shingle and rocks. It also includes bare maritime habitats above the tide-line, such as shingle beaches, mobile sand dunes and bare rocks or soil of coastal cliffs. A covering of sparse vegetation, such as pioneer saltmarsh, dune or shingle species will not put the beach into a vegetated class unless the majority of the substratum is covered.

Distinction of this cover type is dependent on the level of the tide on the days of imaging (the lower tide being used to define the lower limit of the beach). Thus discrepancies can arise where high tides prevailed on imaging.

Fuller key-name: bare coastal mud, silt, sand, shingle and rock, including coastal accretion and erosion features above high water.

SALTMARSH/SEAWEED (class 4)

Areas of seaweeds are sometimes sufficiently extensive to show as vegetated intertidal plant communities. They may comprise the green alga *Enteromorpha intestinalis* or the brown wracks (*Pelvetia canaliculata*, *Fucus* spp. and *Ascophyllum nodosum*) growing on rocks, boulders and sometimes gravels, sands and muds. Saltmarshes are intertidal sand-, silt- or mud-based habitats, colonised by halophytic grasses such as *Puccinellia* spp., and herbs such as *Limonium* spp., *Aster tripolium* and *Triglochin maritima*. They remain mostly green in winter. For the purposes of this classmap, only those marshes up to

normal high water spring tides (ie those flooded monthly) are included. The upper saltmarsh, inundated only on extreme high-water spring tides, is dominated by coarse grasses such as *Agropyron* spp.. These are classified accordingly as rough grasslands.

Distinction of this cover type is dependent on the level of the tide on the days of imaging (the lower tide being used to define the lower limit of the seaweed beds or saltmarshes). Thus discrepancies can arise where high tides prevailed on imaging.

Fuller key name: intertidal seaweed beds and saltmarshes up to normal levels of high water spring tides.

AGRICULTURAL AND AMENITY GRASSLANDS (classes 6 9 and 7)

Agricultural grasslands comprise many types, from newly sown leys, of single species, to largely unimproved swards of indigenous species. This range is subdivided in many different ways by the many different surveys of grasslands (see Fuller 1987). Here we must be constrained by what is possible, with acceptable accuracy, using satellite imaging. Certainly, the class 'agricultural and amenity grasslands' can be identified with good consistency. It characteristically forms a cropped sward, comprising finer grass species (eg *Festuca*, *Agrostis*, *Lolium* and *Poa* spp.) often with many other grasses and herbs. The sward is maintained by mowing and/or grazing, such that coarser species of grass, herbs and scrub cannot become dominant.

In agricultural and conservation terms, there is an important distinction between 'improved' and 'unimproved' swards. Improvement may involve reseeding, herbicide treatments, and/or fertiliser applications which promote the growth of 'preferred' species, especially *Lolium perenne*. Swards which are essentially 'unimproved', or which have reverted, contain a dominant proportion of indigenous species (Fuller 1987).

Improved pastures or close-mown amenity swards are mostly distinguishable on satellite imagery: they remain green in both summer and winter. Unimproved swards are generally used at a low intensity and are typically unenclosed. They are also likely to be discernible from intensive pastures because of their rougher texture, their weed content and the quantity of plant litter they carry in winter (all factors which affect overall reflectance). The problem is that hay meadows, of both the lowlands and the partially improved lower slopes of upland areas, could be confused with either improved or unimproved swards, depending on the stage of management in the particular year of imaging eg growing hay, standing hay, cut hay, aftermath-grazed. This obviously depends on the date of the image available for classification (and only days may separate the four types).

The classification will identify two subclasses of agricultural/amenity grassland, which might be retained as separate class numbers in the database, but could be aggregated to a single colour-class for map and data outputs, depending on the measured accuracy and user requirements. It should be realised that the classes are readily inter-changeable by changing management practices, and such changes may take place on a cyclical basis (eg where swards are mown one year grazed another). The two agricultural/amenity grass subclasses are described below.

Pasture/amenity turf (class 6)

Pastures and amenity turf grasslands are managed either as agriculturally productive swards or mown as amenity grasslands. They are mostly agriculturally 'improved' by reseeded and/or fertiliser use and would normally contain high quantities of *Lolium perenne* and/or other preferred species. Their key characteristic is that they did not, at either date of imaging (summer or winter), have any detectable quantity of dead plant material, nor a substantial uncropped stand of living material. This implies that the swards were grazed or cut and thus maintained as a turf throughout the growing period. This management prevented the sward from reaching flowering height in summer and ensured that there was little or no standing crop of plant litter to influence the winter-reflectance of the sward.

Fuller key-name: pastures and amenity swards, mown or grazed, to form a turf throughout the growing season.

Meadows, verges and seminatural cropped swards (class 7)

Meadows and verges include grasslands which are managed, but mostly at a lesser intensity than the 'mown/grazed turf' class. Partial improvement favours productive species such as *Lolium perenne*, and herbicide treatment may reduce the content of broadleaved 'weeds' but some of the swards in this category represent the traditional hay meadows which have escaped improvement. The swards may be mown for hay and perhaps aftermath-grazed.

Seminatural swards may have much the same appearance. *Festuca/Agrostis* swards are typical of the indigenous, essentially unimproved grasslands, of neutral to acid soils, mostly enclosed, formerly covering much of Britain's grazing land, but now restricted to upland margins and odd pockets of lowlands, usually on floodplains. The swards are characterised by *Festuca rubra* and/or *ovina*, *Agrostis stolonifera*, *A. tenuis* and/or *A. canina*, often with substantial quantities of rushes (*Juncus* spp.), sedges (*Carex* spp.) and broadleaved plants. Alternatively, the seminatural grasslands may be agriculturally non-productive swards which are managed by occasional cutting to prevent excessive weed or scrub growth, eg roadside verges, country parks, golf course semi-rough areas.

The key characteristic of this class is that the swards were not a short-cropped turf throughout the year - either they were grazed at low intensity such that patches of unpalatable species became sufficiently dominant to produce a higher standing crop than on pastures. Or the swards were used for hay and appeared as a long grass sward awaiting mowing or grazing: or, perhaps, they had recently been mown for hay. The important characteristic is that they were cropped by the time of winter imaging, to remove the much of the standing crop of grass. Thus, by winter they were mostly green rather than a straw-coloured stand of plant-litter as would be typical of natural swards of coarse grasses. This class forms a transition, often in appearance, perhaps in species contents and productivity, often in terms of time (ie improving or reverting) and especially space (a transition zone), between improved pastures and the 'natural' grasslands of heaths and moors.

Fuller key-name: Meadows, verges, low intensity amenity grasslands and seminatural cropped swards, not maintained as a short turf.

LOWLAND ROUGH HERBACEOUS (classes 8 and 19)

The lowland rough herbaceous classes comprise two types, separated to distinguish established rough swards from new colonisation.

Marsh/rough grassland (class 8)

This category includes lowland herbaceous vegetation of fens, marshes, upper saltmarshes, and rough or derelict ground. The characteristic feature of this category is that the swards are not significantly cropped by mowing or grazed by stock. In fact most are unenclosed grasslands, abandoned from economic use. The result is that they have a high standing crop of vegetation, most of which dies back in winter, leaving a dense plant litter.

Fuller key-name: lowland marsh/rough grasslands, mostly uncropped and unmanaged, forming grass and herbaceous communities, of mostly perennial species, with high winter-litter content.

Ruderal weeds (class 19)

The ruderal weeds cover-type is generally bare ground being colonised by annual and short-lived perennial plants, usually with a considerable remnant of bare ground, especially in winter. The ground may be naturally bare, eg shingle beaches, or abandoned arable land, eg setaside, or derelict industrial works such as demolished factories, gravel pits etc. This category is rarely extensive enough to map, was chosen to classify what might have been extensive areas of setaside, and is aggregated with the rough grass class for maps and most data summaries.

Fuller key-name: ruderal weeds colonising natural and man-made bare ground.

BRACKEN (class 12)

The bracken class is herbaceous vegetation dominated by *Pteridium aquilinum*. It may be upland or lowland, mixed with grass and other species. The obvious characteristic is that the distinctive colour of winter bracken dominates the reflectance of the community.

Fuller key-name: bracken-dominated herbaceous communities.

GRASS HEATHS AND MOORS (classes 5 and 9)

There are potential problems of confusion between lowland grass heaths and upland grass moors, largely because the species complements are similar. However, there are sufficient differences that spectral separation may be reliable. It has also proved possible to separate the two using a digital mask to correct regional misclassifications (see introduction). Some users of the maps and data may choose to aggregate the two classes, for later separation in a GIS, but using their own contextual definition based on altitude, climate, latitude and longitude or combinations of any such variables.

Lowland grass heaths (class 5)

This category includes coastal dunes and inland grasslands typically growing on sandy soils, usually acid in character. The species might include, on coastal dunes, *Ammophila arenaria*, *Festuca rubra* and *Carex arenaria* and a wide variety of herbaceous species, often winter annuals. Inland, and on mature 'grey' dunes, all but *Ammophila* might be present, but acid-loving species are typical, including *Festuca ovina*, *Agrostis* spp. and *Deschampsia flexuosa* set in a carpet of lichens and mosses (Duffey et al. 1974). The latter species are also characteristic of marginal hill-grasslands and a zone of seminatural acid grassland may lie between the agricultural grasslands of lower hill-slopes and moorland communities on the hill tops. These swards are characteristic of north-western Britain, mostly on land between 100-200m, but right down to sea level in north-west Scotland.

In winter, the lowland grass heaths have substantial quantities of dead plant litter, distinguishing the lowland grass heaths from agricultural swards, but the litter content is less than is typical of coarse rough grasslands, offering a spectral distinction from these.

Fuller key-name: seminatural, mostly acid, grasslands of dunes, heaths and lowland-upland margins

Montane/hill grass (class 9)

This category includes upland swards, mostly of deciduous grasslands, often referred to as grass moorland or upland grassy heath. They are typically dominated by *Nardus stricta* and/or *Molinia caerulea*, with *Festuca ovina*, *Deschampsia caespitosa*, *Juncus* spp. often including sparse cover of upland dwarf shrubs. These swards form large tracts of mostly unenclosed hill-grasslands, lightly grazed often by sheep.

Fuller key-name: montane/hill grasslands, mostly unenclosed *Nardus/Molinia* moorland.

DWARF SHRUB HEATHS (classes 13 and 11)

Lowland heath (class 13)

Lowland heath refers to communities with high contents of heather (*Calluna*), ling (*Erica* spp.) but perhaps mixed with broom (*Cytisus scoparius*), gorse (*Ulex* spp.). It is mostly evergreen, hence different from other scrub communities. Almost invariably, it represents vegetation on sandy soils, in characteristic sites like the Brecklands, and the Dorset and Surrey Heaths, or on extensive coastal dune systems.

Fuller key-name: lowland evergreen shrub-dominated heathland.

Upland dwarf shrub moorland (class 11)

The upland dwarf shrub communities include heather (*Calluna vulgaris*), ling (*Erica* spp.) and bilberry (*Vaccinium* spp.) moorlands. Though dominated by woody shrubs, these may be mixed with herbaceous species, especially those of the montane grasslands. The dwarf shrub moorlands may be managed by muir-

burning, in which case they may be bare, for most of the first year after burning; then the dwarf-shrub/grass mixture (class 10) is found until dwarf shrub growth again dominates the cover.

Fuller key-name: upland evergreen dwarf shrub-dominated moorland.

DWARF SHRUB/GRASS MIXTURES (classes 10 and 25)

Dwarf shrub/grass moorland (class 10)

This cover type is fairly commonplace on some marginal hill grazing land, especially in northern and western parts of Britain, where grazing prevents the dominance of dwarf shrub species. It is also extensive in *Calluna* moorland, as a result of muir-burning to maintain young heather regrowth to promote grouse populations. Initial regrowth produces grassy swards, which over a period of years revert to heather-cover. As the heather senesces, so moorland is re-burnt, with a repeat cycle of perhaps 10 years. Whereas other transient cover-features of management (eg haycutting, arable crop-type) are not defined because of their short-lived nature, the 10-year cycle is judged long enough to justify the distinction between currently managed and unmanaged areas. The proportionate cover of *Calluna* which is required to alter the classification from 'burnt' back to 'dwarf shrub' is not yet clear: this will become evident on comparison of classmaps with corresponding 1 km field squares of Countryside 1990.

Fuller key-name: upland, dwarf shrub/grass moorland.

Dwarf shrub/grass heath (class 25)

This category complements the above moorland variety of dwarf shrub/grass mixtures. However, because intensive grazing of lowland heaths is no longer practiced, the incidence of this class is rare. It will be found where knowledge-correction has identified an area of shrub/grass mixture as being in a lowland zone.

Fuller key-name: lowland, dwarf shrub/grass heathland.

UPLAND AND LOWLAND BOGS (classes 17 and 24)

Bogs are widespread in upland areas especially to the north and west of Britain. They are also found locally in lowland areas. They are characterised by permanent waterlogging, resulting in depositions of acidic peat. As with other heathland and moorland classes, a distinction is made between upland and lowland variants of this class.

Upland bogs (class 17)

Upland bogs have many of the species of grass and dwarf shrub heaths and moors, but are characterised by water-logging, perhaps with surface water, especially in winter. The water-logging promotes species such as bog myrtle (*Myrica gale*) and cotton grass (*Eriophorum* spp.) in addition to the species of grass and dwarf shrub moorlands.

Lowland bogs (class 24)

Lowland bogs are rare in much of Britain, due to drainage and peat extraction. However, local large areas of bog are to be found on the west coast of Scotland. They carry most of the species of upland bogs, but in an obviously lowland context, with *Myrica gale* and *Eriophorum* spp. being highly characteristic.

SCRUB/ORCHARD (class 14)

Scrub and orchard areas are deciduous, often with substantial herbaceous vegetation. Typical species include willow (*Salix* spp.) in wetlands, or hawthorn (*Crataegus monogyna*), brambles (*Rubus fruticosus* agg.) and saplings or small trees: these include, of course, fruit trees. Although commonplace, the scrub category is rarely extensive enough to record more than just a few pixels. The exceptions are in areas of orchards (though these are only found in a few areas), and in seminatural vegetation, for example, the willow-carr woodlands of the Broads or hawthorn scrub on chalk downland. For map-production purposes and in most data summaries it is intended to amalgamate the scrub and deciduous woodland classes.

Fuller key-name: deciduous scrub and orchards.

DECIDUOUS WOOD (class 15)

This category includes all deciduous trees, broadleaved and coniferous. The deciduous characteristic separates it from evergreen species, as it appears bare in winter. However, deciduous woodland has a unique spectral signature which separates it from other deciduous vegetation and from arable land. Mixed woodland may be included with this category, though continuous evergreen stands, where greater than minimum mappable area, will be separated.

Fuller key-name: Deciduous broadleaved, coniferous and mixed woodlands.

EVERGREEN WOOD (class 16)

Evergreen woodland includes most coniferous species, plus other evergreens such as holly (*Ilex aquifolium*), Rhododendron (*R. ponticum*), yew (*Taxus baccata*) or Holm oaks (*Quercus ilex*). As well as remaining in leaf all year round, the species generally have very dark leaves or needles, giving them unique signatures in both summer and winter.

Fuller key-name: Conifer and broadleaved evergreen trees.

ARABLE LAND (class 18)

Arable land includes all land under annual tillage, especially for cereals, horticulture etc. It also includes leys in their first year, ie if they were bare at the time of the winter imagery. Other land, vegetated at the time of summer imagery but bare soil during the winter, is also included in this land cover type: hence any temporarily bare ground (eg from scrub-clearance, development, mining or soil tipping) would be classified in this category.

Fuller key-name: arable and other seasonally or temporarily bare ground.

SUBURBAN/FARMS (class 20)

The suburban/farms category includes all land where the pixels of the Landsat image have recorded a mixture of built-up land and permanent vegetation. Most suburban and rural developments, where the buildings and associated car-parks etc. remain small enough that they do not fill all of each pixel, are included in this cover-type. Small rural industrial estates, glasshouses, railway stations, larger rural roads, villages, small retail sites are all included in this class.

Fuller key-name: suburban and rural developed land comprising buildings and/or roads but with some cover of permanent vegetation

URBAN/INDUSTRIAL (class 21)

The urban/industrial class covers all developments which are large enough to completely fill individual pixels, to the exclusion of significant quantities of permanent vegetation. It includes cities, large town centres, major industrial and commercial sites, major areas of concrete and tarmac, plus permanent bare ground associated with these developments, such as car-parks and tips.

Fuller key-name: industrial, urban and any other developments, lacking permanent vegetation.

BARE GROUND (class 22)

The bare ground category includes all 'natural' surfaces such as rock, sand, gravel or soil, though their origin has often not been natural: the exceptions are coastal features which classify as beaches/flats. Ground which has been bared by human activities, or by livestock would be included. Imported surfaces of sand or gravel (eg car parks) would also be classed as bare ground.

Fuller key-name: ground bare of vegetation, surfaced with 'natural' materials.

FELLED FOREST (class 23)

Recently felled forest, still bare from felling and the associated disturbance, usually with large quantities of brush-wood etc, comprise this class. As they revegetate, felled areas recolonise and enter other classes: generally they pass through a short phase (perhaps one year) as ruderal weeds, then become rough grassland, later scrub, and, if replanted, after perhaps ten years, felled areas take the appropriate deciduous or evergreen class.

Fuller key-name: felled forest, still largely bare ground and forestry waste.

REFERENCES

Duffey, E., Morris, M.G., Sheail, J., Ward, L.K. & Wells, T.C.E. 1974. *Grassland ecology and wildlife management*. London: Chapman & Hall.

Fuller, R.M. 1987. The changing extent and conservation interest of lowland grasslands in England and Wales: a review of grassland surveys 1930-1984. *Biological conservation* 40, 281-300.

Townshend, J.R.G. 1983. Effects of spatial resolution on the classification of land cover type. In: *Ecological mapping from ground, air and space* edited by R.M. Fuller. Cambridge: Institute of Terrestrial Ecology.

Table 1. A suggested Landsat classification of Great Britain into land cover classes. Classes which are boxed together are those where spectral separation may be unreliable. In some cases, problems of spectral confusion (eg between beaches and other bare ground) is overcome by knowledge-based correction (eg using a digital coastline): in these circumstances, the classes are not boxed. Elsewhere (eg the use of altitude in separating 'lowland grass heath' from 'grass moors') the dividing line is less clear and could present difficulties, at least outside of a GIS environment, so the classes are boxed together.

NUMBERING AND NOMENCLATURE FOR CLASSES IN THE LAND COVER OF BRITAIN

