



<b>Title</b>	<b>CPW-coupled-fed elliptical monopole UWB antenna with dual-band notched characteristic</b>
<b>Author(s)</b>	<b>Zhang, J; Cheung, SW; Yuk, TI</b>
<b>Citation</b>	<b>The 2012 Progress In Electromagnetics Research Symposium (PIERS 2012), Kuala Lumpur, Malaysia, 27-30 March 2012. In Progress in Electromagnetics Research Symposium, 2012, p. 823-827</b>
<b>Issued Date</b>	<b>2012</b>
<b>URL</b>	<b><a href="http://hdl.handle.net/10722/165221">http://hdl.handle.net/10722/165221</a></b>
<b>Rights</b>	<b>Creative Commons: Attribution 3.0 Hong Kong License</b>

# CPW-coupled-fed Elliptical Monopole UWB Antenna with Dual-band Notched Characteristic

J. Zhang, S. W. Cheung, and T. I. Yuk

Department of Electrical and Electronic Engineering  
The University of Hong Kong, Hong Kong, China

**Abstract**— This paper presents the results of a coplanar-waveguide (CPW)-coupled-fed elliptical monopole UWB antenna (CCFEMUA) with a dual band-notched characteristic. The antenna has a large bandwidth covering the frequency band from 2.4 GHz to 15.2 GHz with the return loss larger than 10 dB. Two band notches at 3.7 GHz and 4.8 GHz are realized by cutting two half-elliptical-arc slots on the radiation patch. The return loss, radiation pattern, peak gain and efficiency of the antenna are studied using computer simulation.

## 1. INTRODUCTION

The FCC (Federal Communications Commission) released an unlicensed frequency band of 3.1–10.6 GHz for ultra-wideband (UWB) applications in 2002 [1]. Since then design of UWB antennas has been attracting much attention. UWB commonly refers to signals or systems that either have a large relative or a large absolute bandwidth [2]. Such large bandwidth offers specific advantages of low power consumption and high data rate which promise solutions for short-range and high-speed indoor mobile communications. The design of UWB antennas is quite challenging because it has to satisfy the requirements of wide impedance bandwidth, omnidirectional radiation pattern, constant gain, high radiation efficiency, constant group delay, low profile and easy manufacturing [3]. Besides these, the UWB antennas should also have notch characteristic to prevent interfering with other systems using frequency bands with the UWB.

UWB antennas with different radiator shapes such as square [4], circular [5], pentagonal [6], hexagonal [7], elliptical [8], ring [9] and trapezoidal [10], different types such as monopoles [6–8, 10–12], dipoles [13] and slot antennas [9], different feeding structures such as microstrip [6, 7, 10, 11], co-planar-waveguide (CPW) [8, 9, 12] and coaxial [14], and different methods for creating the band-notched characteristics have been studied [8, 15, 16]. In this paper, we propose a very simple design of a CPW-coupled-fed elliptical monopole UWB antenna (CCFEMUA) with dualband notched characteristic. The two band notches are achieved by cutting two arc slots on the radiator. The return loss, radiation pattern, peak gain, and efficiency are studied using the EM simulation tool CST.

## 2. ANTENNA DESIGN

The configuration of the proposed dualband notched CCFEMUA is shown in Fig. 1. The antenna is composed of a feeding structure on one side of the substrate and a radiating patch on the other side of it. The antenna is designed in a substrate with a dielectric constant of  $\epsilon_r$  and thickness of  $h$ . The radiating patch has a simple elliptical shape with the major and minor axes having lengths of  $2rx$  and  $2ry$  in the  $y$  and  $z$  directions, respectively. The feeding structure is a CPW terminated with a trapezium patch with a topline of  $w_3$ , baseline of  $w_2$  and height of  $d$  as shown in Fig. 1. The trapezium patch is used to couple the signal from the CPW to the radiating patch on the other side of the substrate. The width of the CPW tapers from  $w_1$  to  $w_2$  for achieving good impedance match. Two notch bands at 3.7 GHz and 4.8 GHz are generated by cutting two half-elliptical-arc slots on the radiating patch as shown in Fig. 2. The lower arc slot in Fig. 2(a) and upper arc slot in Fig. 2(b) are responsible for the notch bands at 3.7 GHz and 4.8 GHz, respectively.

## 3. RESULTS AND DISCUSSIONS

The proposed dual-band notched CCFEMUA is optimized in terms of impedance bandwidth using the EM simulation tool, CST. The simulated return loss in Fig. 3 show that the antenna has an impedance bandwidth (return loss  $> 10$  dB) from 2.4 to 15.2 GHz, covering the bandwidth from 3.1–10.6 GHz for UWB applications. The two notch bands are created at 3.7 GHz and 4.8 GHz.

The simulated radiation patterns of the antenna in the  $x$ - $y$ ,  $x$ - $z$  and  $y$ - $z$  planes at 2.4, 3.0, 3.7, 4.8, 10.0 and 15.2 GHz are shown in Fig. 4. Due to the wavelength is much larger than the antenna

size at 2.4 and 3.0 GHz, the patterns in the  $x$ - $y$  plane are approximately omnidirectional. The radiation patterns in the  $x$ - $z$  and  $y$ - $z$  planes are approximately symmetrical along the  $y$ -axis. As the electrical length of the radiator increases at the higher frequencies of 10 GHz and 15.2 GHz, the radiation patterns in the  $y$ - $z$  plane are still symmetrical along the  $y$ -axis, but side lobes appear. The radiation patterns in the  $x$ - $z$  plane become asymmetrical because the front (with the feed-line structure) and back (with the radiator) of the antenna structure are not symmetrical. At the notch frequencies of 3.7 GHz and 4.8 GHz, it can be seen that the peak gains are suppressed by about 6 and 5 dB, respectively, compared to that at 3 GHz.

The simulated peak gain and efficiency of the antenna are shown in Fig. 5. It can be seen that there are two notches occurring at the notched frequencies of 3.7 and 4.8 GHz, with the gains

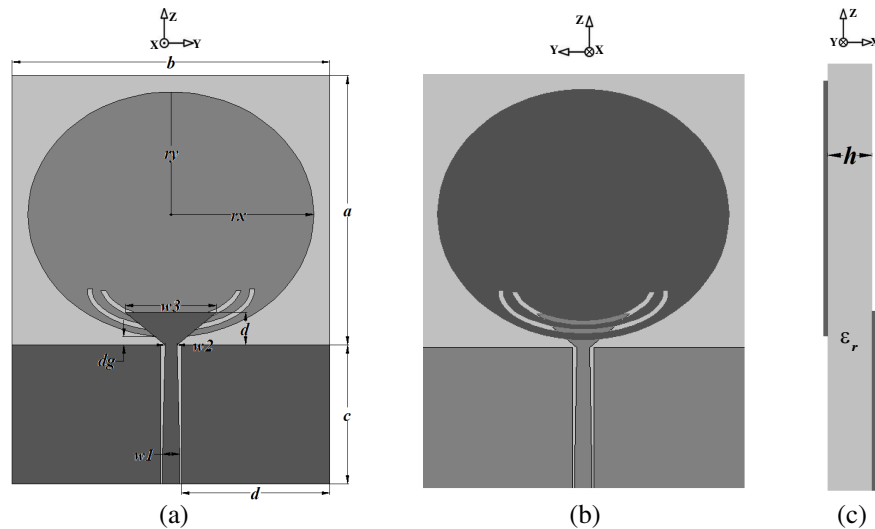

Figure 1: Geometry of antenna. (a) Front view, (b) back view and (c) side view.  $\epsilon_r = 3.5$ ,  $h = 0.8$  mm,  $r_x = 18$  mm,  $r_y = 15$  mm,  $w_1 = 2.2$  mm,  $w_2 = 1.5$  mm,  $w_3 = 11.5$  mm,  $d = 4$  mm,  $d_g = 1$  mm,  $a = 33$  mm,  $b = 40$  mm,  $c = 17$  mm,  $d = 18.7$  mm.

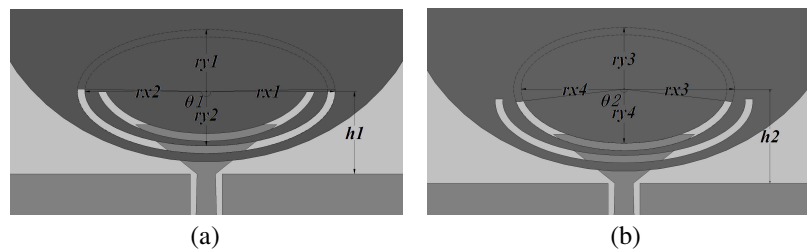

Figure 2: Half-elliptical-arc slots with large scale Dimensions of (a) lower slot with  $h_1 = 6.7$  mm,  $\theta_1 = 185^\circ$ ,  $r_{x1} = 10.5$  mm,  $r_{y1} = 5$  mm,  $r_{x2} = 9.9$  mm,  $r_{y2} = 4.4$  mm, and (b) upper slot with  $h_2 = 7.7$  mm,  $\theta_2 = 155^\circ$ ,  $r_{x3} = 9$  mm,  $r_{y3} = 5$  mm,  $r_{x4} = 8.4$  mm,  $r_{y4} = 4.4$  mm.

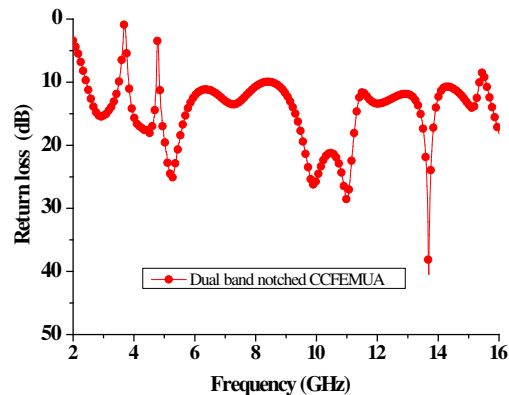
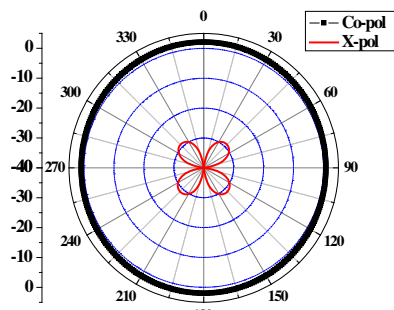
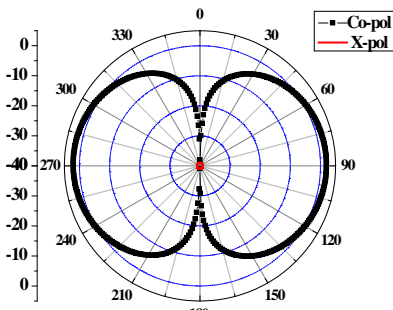

Figure 3: Return loss.



(a)



(b)

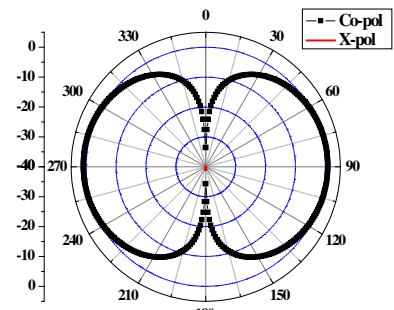

(c)

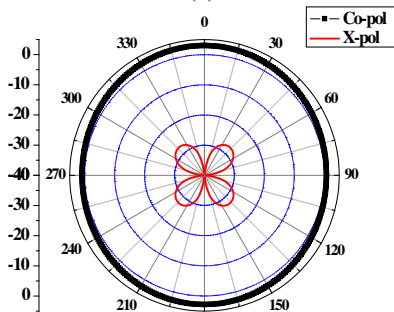

(d)

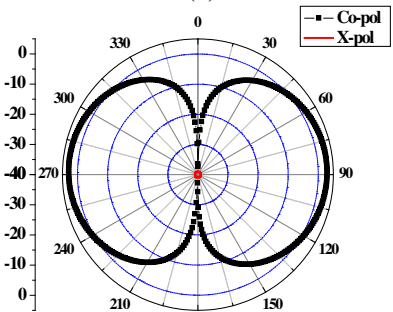

(e)

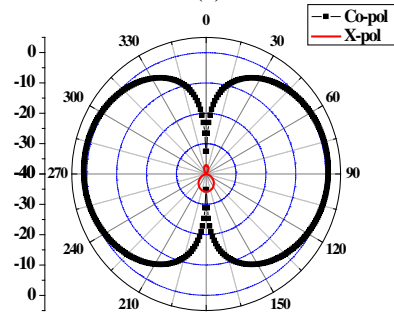

(f)

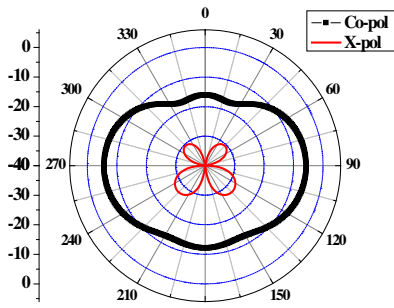

(g)

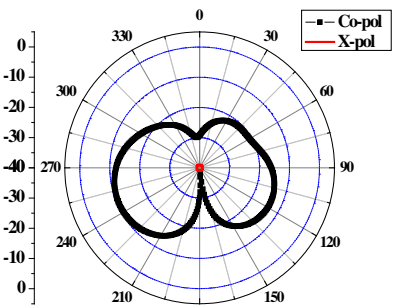

(h)

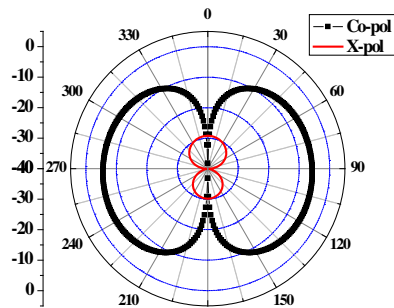

(i)

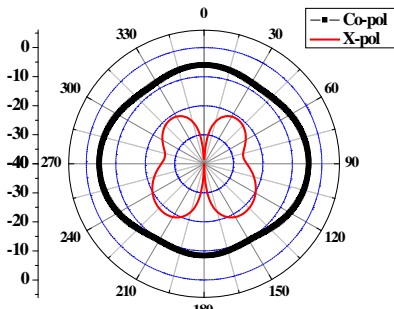

(j)

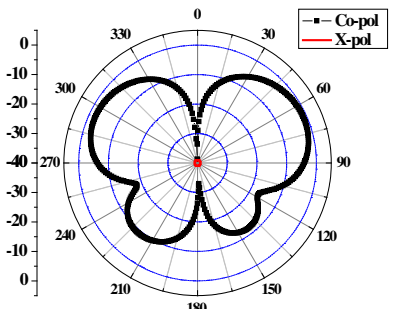

(k)

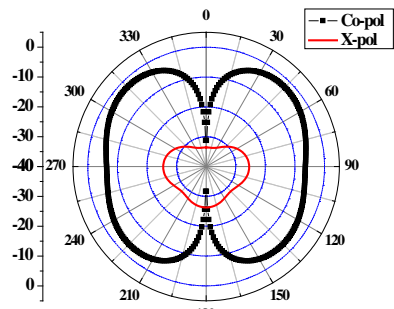

(l)

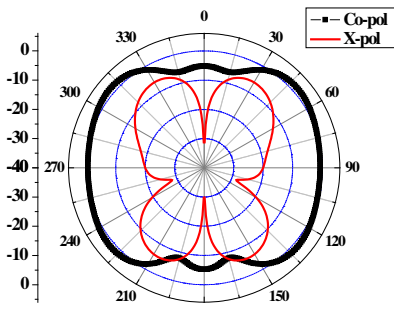

(m)

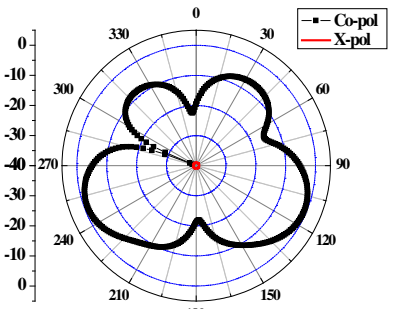

(n)

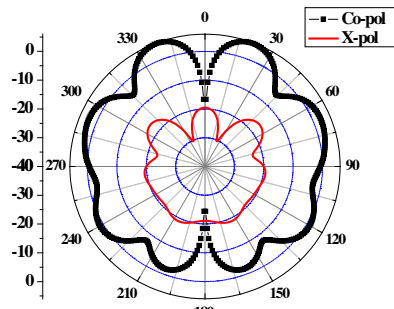

(o)

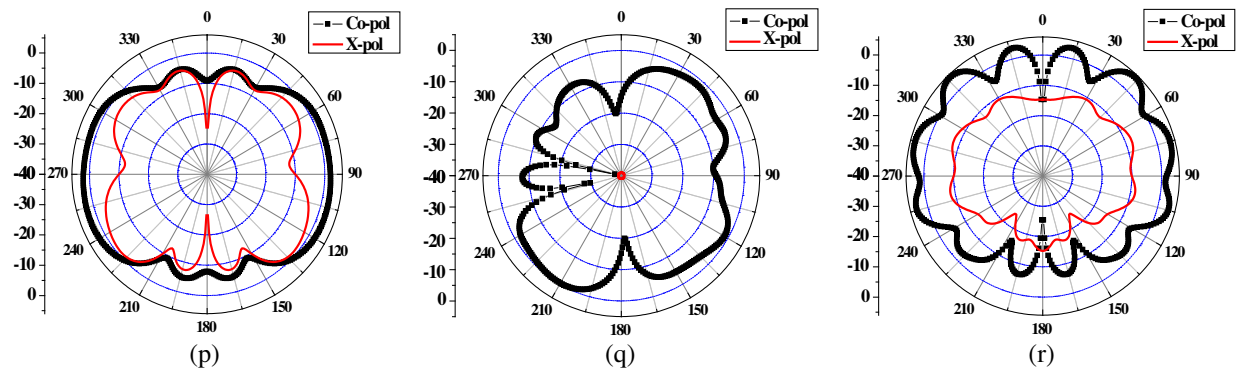

Figure 4: Simulated radiation patterns. 2.4 GHz in (a)  $x$ - $y$ , (b)  $x$ - $z$  and (c)  $y$ - $z$  plane; 3 GHz in (d)  $x$ - $y$ , (e)  $x$ - $z$  and (f)  $y$ - $z$  planes; 3.7 GHz in (g)  $x$ - $y$ , (h)  $x$ - $z$  and (i)  $y$ - $z$  planes; 4.8 GHz in (j)  $x$ - $y$ , (k)  $x$ - $z$  plane and (l)  $y$ - $z$  planes; 10 GHz in (m)  $x$ - $y$ , (n)  $x$ - $z$  plane and (o)  $y$ - $z$  planes; 15.2 GHz in (p)  $x$ - $y$ , (q)  $x$ - $z$  plane and (r)  $y$ - $z$ .

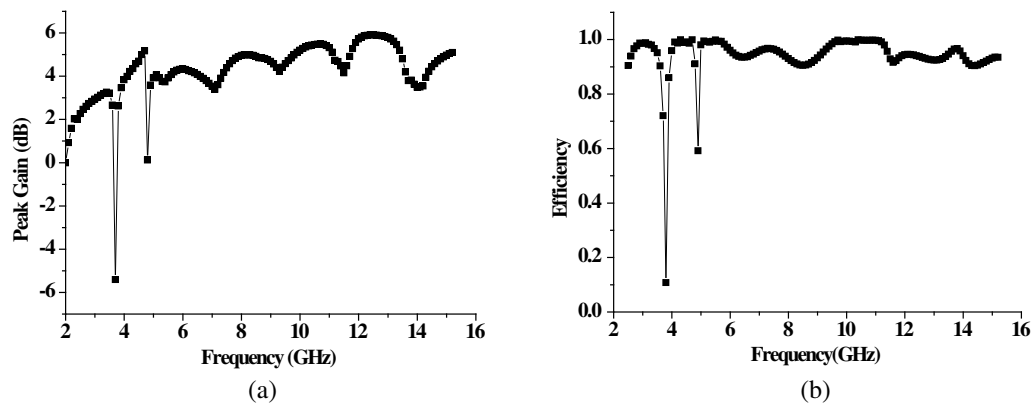

Figure 5: Efficiency and peak gain. (a) peak gain, (b) efficiency.

suppressed to  $-5$  dBi and  $0.1$  dBi and radiation efficiencies reduced to 10% and 60%, respectively.

#### 4. CONCLUSIONS

The design of a CCFEMUA with a dual band-notched characteristic has been presented. The antenna is simple and has a CPW-coupled-fed structure with an elliptical patch for radiation. Two half-elliptical-arc slots are cut on the radiator to generate two band notches at 3.7 GHz and 4.8 GHz. Simulation results have shown that it has a wide operation bandwidth of 2.4–15.2 GHz and approximately omnidirectional radiation patterns, and so is suitable for UWB applications.

#### REFERENCES

1. Federal Communications Commission, First Report and Order, Revision of Part 15 of the Commission's Rules Regarding Ultra-wideband Transmission Systems, FCC 02-48, Apr. 2002.
2. Schantz, H., *The Art and Science of Ultra Wideband Antennas*, Artech House Inc., 2005.
3. Ghavami, M., L.B. Michael, and R. Kohno, *Ultra Wideband Signals and Systems in Communication Engineering*, John Wiley and Sons, New York, USA, 2004.
4. Ojaroudi, M., C. Ghobadi, and J. Nourinia, "Small square monopole antenna with inverted T-shaped notch in the ground plane for UWB application," *IEEE Antennas and Wireless Propagation Letters*, Vol. 8, 728–731, 2009.
5. Chiaw, C. C. and M. R. Kamarudin, "Novel design of circular UWB antenna," *Asia Pacific Microwave Conference*, Singapore, 1977–1979, 2009.
6. Shrivastava, V. and Y. Ranga, "Ultra wide band CPW-fed printed pentagonal antenna with modified ground plane for UWB applications," *IET International Conference on Wireless Mobile and Multimedia Networks*, 1–2, Beijing, China, 2008.
7. Panda, J. R. and R. S. Kshetrimayum, "A compact CPW-fed hexagonal 5 GHz/6 GHz band-notched antenna with an U-shaped slot for ultrawideband communication systems," *International Conference on Signal Processing and Communications*, Bangalore, India, 1–5, 2010.

8. Weng, Y. F., S. W. Cheung, and T. I. Yuk, “Compact ultra-wideband antennas with single band-notched characteristic using simple ground stubs,” *Microwave and Optical Technology Letters*, Vol. 53, No. 3, Mar. 2011.
9. Azim, R., M. T. Islam, and N. Misran, “Printed circular ring antenna for UWB application,” *International Conference on Electrical and Computer Engineering*, 361–363, Dhaka, Bangladesh, 2010.
10. Lee, S. H., J. K. Parka, and J. N. Lee, “A novel CPW-fed ultra-wideband antenna design,” *Microwave and Optical Technology Letters*, Vol. 44, No. 5, Mar. 2005.
11. Nazli, H., E. Bicak, B. Turetken, and M. Sezgin, “An improved design of planar elliptical dipole antenna for UWB applications,” *IEEE Antennas and Wireless Propagation Letters*, Vol. 9, 264–267, 2010.
12. Zhang, Z. C., C. J. Guo, J. Ding, and Y. Su, “A novel printed UWB monopole antenna fed by coaxial cable,” *International Conference on Microwave and Millimeter Wave Technology*, 25–27, 2010.
13. Chu, Q.-X. and Y.-Y. Yang, “A compact ultrawideband antenna with 3.4/5.5 GHz dual band-notched characteristics,” *IEEE Transactions on Antennas and Propagation*, Vol. 56, No. 12, 3637–3644, Dec. 2008.
14. Eshtiaghi, R., J. Nourinia, and C. Ghobadi, “Electromagnetically coupled band-notched elliptical monopole antenna for UWB applications,” *IEEE Transactions on Antennas and Propagation*, Vol. 58, No. 4, 1937–1402, Apr. 2010.
15. Weng, Y. F., W. J. Lu, S. W. Cheung, and T. I. Yuk, “UWB antenna with single or dual-band notched characteristic for WLAN band using meandered ground stubs,” *Loughborough Antennas & Propagation Conference*, 767–760, Nov. 2009.
16. Weng, Y. F., S. W. Cheung, and T. I. Yuk, “An antenna for UWB and bluetooth standards with band-notched characteristic,” *International Conference on Ultra-wideband*, 170–174, Sep. 2009.