

Title	Design of a single ultra-low-loss magnetic ballast for a wide range of T5 high-efficiency fluorescent lamps
Author(s)	Ng, WM; Lin, DY; Hui, SY
Citation	IEEE Transactions on Industrial Electronics, 2012, v. 59 n. 4, p. 1849-1858
Issued Date	2012
URL	http://hdl.handle.net/10722/155685
Rights	IEEE Transactions on Industrial Electronics. Copyright © IEEE

Design of a Single Ultra-Low-Loss Magnetic Ballast for a Wide Range of T5 High-Efficiency Fluorescent Lamps

W. M. Ng, *Member, IEEE*, Deyan Y. Lin, *Member, IEEE*, and S. Y. Hui, *Fellow, IEEE*

Abstract—A patent-pending single design of an ultralow-loss (ULL) magnetic ballast for T5 high-efficient (T5-HE) fluorescent lamps rated from 14 to 35 W is presented. Based on the use of a nonlinear physical low-pressure discharge lamp model, it is discovered that the same set of ballast parameters can be chosen for operating T5-HE 14-, 21-, 28-, and 35-W lamps at their respective rated power at a mains voltage in the range of 220–240 V. With energy efficiency higher than and lifetime much longer than their electronic counterparts and being recyclable, the ULL ballasts offer a more environmentally friendly solution to T5-HE lamps than electronic ballasts. This single-ballast design offers great convenience to both ballast manufacturers and users, because only one product design can cover a range of the most popular T5-HE lamps. Both theoretical analysis and experimental results are included to confirm the validity of the proposal.

Index Terms—Energy saving, lighting control, sustainable lighting technology.

I. INTRODUCTION

THERE has been a trend of using electronic ballasts to replace magnetic ballasts in the last two decades. Up to 2007, it was often believed that electronic ballasts were more energy efficient than magnetic ballasts [1], [2]. However, the short lifetime of electrolytic capacitors commonly used in electronic circuits in lighting applications has been a serious concern, because it limits the lifetime of the entire lighting products [3]–[5]. Typical rated lifetimes of electronic ballasts for compact and tubular fluorescent lamps are 10 000 h (i.e., 1.1 years for 24-h operation) and 15 000 h (1.7 years), respectively. Such short lifetimes mean that a huge amount of electronic waste would have been accumulated due to the use of these electronic ballast products. The health consequences of electronic waste accumulation in the environment and their adverse impacts on environment are very serious, as pointed out in many research papers [6], [7]. Efforts in reducing electronic

Manuscript received July 28, 2010; revised October 15, 2010 and November 22, 2010; accepted December 28, 2010. Date of publication March 14, 2011; date of current version November 1, 2011. This work was supported in part by the Center for Power Electronics, City University of Hong Kong, and in part by the Hong Kong Research Grant Council under Project CityU 122606.

W. M. Ng and D. Y. Lin are with the Department of Electronic Engineering, City University of Hong Kong, Kowloon, Hong Kong (e-mail: eewmng@cityu.edu.hk; deyanlin@student.cityu.edu.hk).

S. Y. Hui is with the Department of Electrical and Electronic Engineering, The University of Hong Kong, Hong Kong, and also with the Department of Electrical and Electronic Engineering, Imperial College London, London, U.K. (e-mail: ronhui@eee.hku.hk).

Color versions of one or more of the figures in this paper are available online at <http://ieeexplore.ieee.org>.

Digital Object Identifier 10.1109/TIE.2011.2126534

TABLE I
INITIAL ASSESSMENT OF LOSS COMPONENTS [11]

Lamp Type	T8 36W	T5 28W
Rated voltage (V _{rms})	103	167
Rated current (Arms)	0.44	0.175
Conduction loss (i^2R)	100%	16%
Core loss ($\propto I$ or ϕ)	100%	40%

components in electronic ballasts have been made [18], and a large-scale lighting network based on recyclable magnetic ballasts has found to be successful [19].

The energy-efficient T5 fluorescent lamps were originally introduced to the lighting market for use with electronic ballasts only. For example, the classifications of ballasts for T5 lamps include electronic ballasts only, and magnetic ballasts are not even considered [8]. Unlike T8 lamps, T5 lamps are high-voltage lamps. While the nominal ON-state lamp voltage of T8 36-W lamps is about 100 V, that of T5 high-efficient (T5-HE) 28-W lamps is about 175 V, which is close to the 220–240-V mains voltage. Thus, it seems that the lamp arc of a T5 28-W lamp may not be able to sustain when it is used with a traditional magnetic ballast. The misunderstanding that T5 lamps cannot be used with magnetic ballasts has been dispelled in [9]. The inductive–capacitive (LC) ballasts previously proposed in countries with low ac mains voltage of 110 V [10] have offered a good solution to overcome the high-lamp-arc-voltage problem, because the capacitive voltage has an opposite polarity of the inductor voltage and therefore cancels part of the voltage drop across the inductor. Contrary to traditional perception, it has been practically proven in [11] that ultralow-loss (ULL) ballasts are, in fact, more energy efficient than electronics ballasts for T5 lamps. The reason for the ULL feature is mainly due to the “low-current” feature of the high-voltage lamps, as illustrated in comparison of T8 and T5 lamps in Table I [12], [13]. The low-current features of T5 lamps imply that the conduction loss and core loss in the choke for T5 lamps will be significantly lower than those in the choke for T8 lamps.

Based on a physical low-pressure discharge lamp model [12], [13], it is further shown in this paper that a single set of LC parameters can be used for powering a range of T5-HE lamps rated from 14 to 35 W. This new discovery leads to the possibility of using one single ballast product for a range of popular T5-HE lamps, including 14-, 21-, 28-, and 35-W lamps. Some preliminary results were reported in a conference paper in [17]. In this paper, the theoretical predictions of the parameters are included. More explanations and relevant references

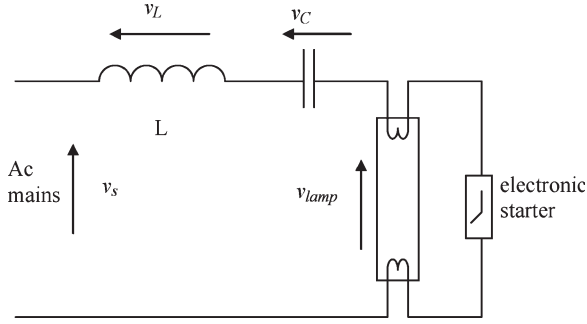

Fig. 1. Schematic of a ULL magnetic ballast system based on an LC circuit for the ULL ballast driven system.

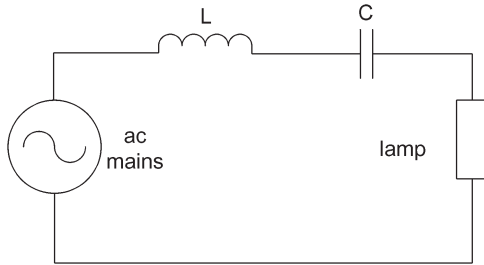

Fig. 2. Simplified circuit model.

are provided. Practical results obtained from T5-HE 14-, 21-, 28-, and 35-W lamps are included to confirm the theoretical predictions. Due to the legal restrictions on the authors, the filament heating and starting processes cannot be disclosed at this stage and therefore are not the focus of this paper. These issues will be addressed in the future when approval is granted for disclosure. Because of the use of magnetic chokes as in the traditional magnetic ballasts, the proposed ULL ballast is particularly suitable for public lighting systems in which reliability against extreme weather conditions is needed and the size of the ballasts is not critical. The proposed system can be dimmed with lamp current control described in [20] via the adjustment of the ac input voltage, as explained in [19].

II. ULL BALLAST AND DISCHARGE LAMP MODEL

Fig. 1 shows the diagram of an ULL magnetic ballast based on an LC circuit. The ballast consists of an inductor and a capacitor. An electronic starter with end-of-life detection is used for lamp ignition. For the analysis, a simplified model of the ballast circuit shown in Fig. 2 is used.

The discharge lamp model is based on the following equations: The steady-state circuit equation for the circuit in Fig. 1 can be expressed in phasor notation as

$$V_s = I_s (r + j(\omega L - 1/\omega C)) + V_{\text{lamp}} \quad (1)$$

where V_s is the ac input voltage, I_s is the input current, r is the winding resistance of the inductor, L is the capacitance, and V_{lamp} is the total voltage across the lamp. For T5-HE lamps, the rated current is specified at 175 mA. From (1), the lamp current equation is

$$I_s = \frac{(V_s - V_{\text{lamp}})}{(r + j(\omega L - 1/\omega C))}. \quad (2)$$

Since V_{lamp} is a highly nonlinear function of time when the lamp is operated at mains frequency, it is appropriate to use an accurate lamp model. To precisely determine the LC ballast parameters for a range of T5-HE lamps, the physical discharge lamp model reported in [12] and [13] is adopted for this study. This lamp model has the unique feature of including the electron density as a variable. This feature allows the model to predict the “turn-on voltage spike” of the discharge lamps, as shown in simulated voltage waveforms in Figs. 9(b)–20(b). For high-voltage lamps with lamp voltage close to the mains voltage, such as T5 28-W lamps, the presence of such voltage spike is an indication that sufficient voltage is available to sustain the lamp arc in each half-cycle of the ac mains.

The lamp model equations are listed as follows:

$$\frac{dT_e}{dt} = a_1(i^2 R - P_{\text{rad}} - P_{\text{con}})/n_e \quad (3)$$

$$P_{\text{rad}} = a_2 n_e \exp(-ea_3/kT_e) \quad (4)$$

$$P_{\text{con}} = a_4(T_e - T_g) * n_e \quad (5)$$

$$\frac{dn_e}{dt} = n_e(v_i - v_{\text{diff}}) \quad (6)$$

$$R = \frac{l}{n_e e \mu_e s} \quad (7)$$

$$v_i = a_5 \exp(-ea_6/2kT) + a_7 E \quad (8)$$

$$v(t) = a_8 L \frac{di}{dt} + r i + R i + V_{\text{ele}} \quad (9)$$

$$v_{\text{diff}} = (2.4/R_a)^2 D_a \quad (10)$$

$$\mu_e = \frac{6701960}{T_e} \quad (11)$$

$$E = i/(n_e e \mu_e s) \quad (12)$$

$$D_a = \mu_i k(T_e + T_g)/e \quad (13)$$

$$\mu_i = a_9 * 0.14 \quad (14)$$

$$T_g = a_{10} i^2 R + T_0 \quad (15)$$

$$\frac{dv_c}{di} = \frac{i}{C} \quad (16)$$

where T_e is the electron temperature, i is the lamp current, R is the lamp resistance, P_{rad} is the radiation loss in the lamp, P_{con} is the thermal conduction loss in the lamp, n_e is the electron density, k is the Boltzmann constant, e is the charge on an electron, v_i is the ionization frequency of every electron, $v(t)$ is the power supply voltage, L is the ballast inductance, r is the ballast resistance, V_{ele} is the electrode voltage drop in the lamp, v_{diff} is the diffusion frequency of every electron, μ_e is the electron mobility, μ_i is the ion mobility, T_g is the gas temperature, T_0 is the lamp wall temperature, C is the ballast capacitance, and V_c is the voltage across the capacitor in the LC ballast.

It can be seen from (3)–(10) that there are ten coefficients for the model. For each type of T5-HE lamps, these coefficients can be obtained from feeding the measured lamp voltage and current waveforms into the model and then use an intelligent algorithm to select the coefficients in order to satisfy an

TABLE II
MODEL PARAMETERS FOR T5 LAMPS

	14W	21W	28W	35W
$a1$	6.23e22	1.34e22	3.11e22	1.21e22
$a2$	4.59e-12	8.52e-12	6.60e-12	6.44e-12
$a3$	33.09	14.43	8.23	44.68
$a4$	1.17e-19	1.91e-19	7.40e-19	1.21e-18
$a5$	8.98e10	3.74e10	3.17e10	7.99e10
$a6$	23.34	26.38	23.50	23.07
$a7$	6.85	3.19	1.64	2.19
$a8$	5.58e15	9.89e15	1.50e15	2.18e14
$a9$	1.01	0.98	1.03	1.00
$a10$	130.00	136.45	114.50	103.97

objective function. Mathematically, the objective function can be expressed as an optimum problem as follows:

$$\begin{aligned}
 & J(a_1, a_2, a_3, a_4, a_5, \dots, a_{10}) \\
 & = \min \left[\sum (V_i - V_i^*)^2 + \sum (I_i - I_i^*)^2 \right] \\
 & a = (a_1, \dots, a_{10}) \in S
 \end{aligned} \tag{17}$$

where V_i and I_i are the simulating voltage and current values, V_i^* and I_i^* are the sampled voltage and current waveforms corresponding to the values of V_i and I_i at the same time, and S is the potential solution space. A set of $\{a_1 \dots a_{10}\}$ should be searched in a space of potential solutions, so that the right side of (17) will be minimized.

III. THEORETICAL ANALYSIS AND PARAMETER DETERMINATION

Experiments have been set up to obtain the measured lamp voltage and current waveforms. With the use of (1) and (2), initial estimation of the inductor and capacitor values can be obtained. Lamp ignition is assisted with the use of an electronic starter. If an ac input voltage higher than the ac mains voltage is needed, an ac power supply with output voltage control is used to increase the ac input voltage for the experiments in order that the T5-HE lamps can be operated and their current and voltage waveforms can be obtained. Under this experimental stage, the values of the ballast inductor and capacitors need not be optimized. Based on the modeling approach described in the last section and the preliminary experimental data, the coefficients for T5-HE 14-, 21-, 28-, and 35-W lamps are obtained and tabulated in Table II. These four sets of coefficients are used in the analysis for determining the values of the inductor and capacitor.

Using this physical discharge lamp model, the LC values of the ULL ballast that can generate lamp power of $\pm 5\%$ of the rated power for the T5 lamps at 14, 21, 28, and 35 W are generated and plotted in Fig. 3. For each T5 lamp, the upper curve refers to the power at 1.05 of the rated power, whereas the lower curve refers to that at 0.95 of the rated power. The procedure for generating each LC curve is based on the model equations (3)–(16) and the parameters in Table I. A matrix of lamp power values is constructed with a practical range of ballast inductor L from 0.2 to 6 H (with an increment 0.2 H) and a practical range of capacitor C from 1 to 3 μF (with an

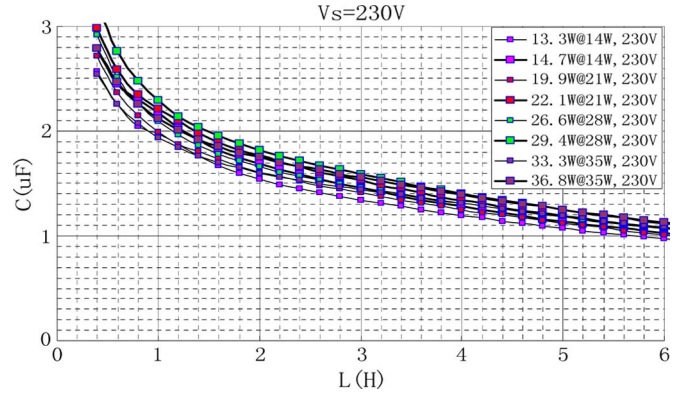

Fig. 3. Predicted lamp power curves with 5% tolerance for T5-HE 14-, 21-, 28-, and 35-W lamps.

increment of 0.1 μF). For each pair of LC values, $v(t)$ is used as a time-stepping function of a 230-V 50-Hz sinusoidal function. The time-stepping procedure generates the lamp voltage $v_{\text{lamp}} = Ri + V_{\text{ele}}$ [from (9)] and the lamp current by solving (16). The instantaneous lamp power is the product of the lamp voltage and lamp current. After the time-stepping procedure completes one full mains cycle, the average lamp power can be determined for each pair of the LC values. These values fill up the matrix table. Then, from the matrix table, the values of the rated power of 1.05 and 0.95 can be selected to plot the respective curves.

Observation of the theoretical results in Fig. 3 shows that the $\pm 5\%$ power curves of the LC sets for the rated-power levels of 14, 21, 28, and 35 W of the T5 lamps almost overlap on each other. This important discovery points to the possibility that any set of the LC values chosen from these overlapped curves can be used to power the whole range of T5 lamps from 14 to 35 W. If this possibility can be practically realized, then one LC ballast design can be used for T5-HE lamps from 14 to 35 W. This attractive feature means that ULL ballast manufacturers can develop only one ballast product to cover T5-HE lamps of 14–35 W, instead of making one ballast product for each lamp type. The accuracy of the physical discharge model has been confirmed previously [12]. Fig. 4 shows the measured and simulated voltage-current characteristic of a T5-HE 28-W lamp.

IV. EXPERIMENTAL VERIFICATION

In order to confirm that this interesting discovery is correct in practice, three sets of LC values are chosen for developing the practical LC ballast prototypes. These three sets of ballasts are tested with the T5-HE lamps of 14–35 W at an ac mains voltage of 230 V and 50 Hz. The three sets of LC values of the ULL ballasts are listed in Table III. Measurements of the lamp power for T5-HE 14-, 21-, 28-, and 35-W lamps are obtained after the respective systems are operated for at least 30 min and are tabulated in Table III.

These power measurements are consistent with the rated-power values. The power measurements of the three sets of ULL ballasts are plotted with the simulated power curves (of $\pm 5\%$ of rated power) for T5-HE lamps of 14, 21, 28, and

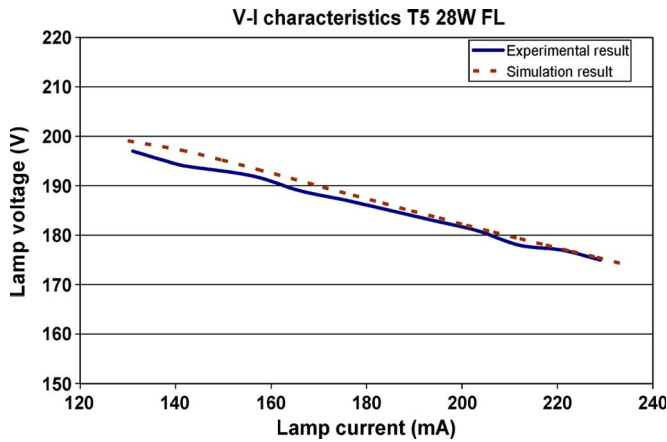

Fig. 4. Simulated and measured voltage–current characteristic of T5 28-W lamp [11].

TABLE III
BALLAST PARAMETERS AND MEASURED LAMP POWER

Ballast / Lamp	T5 14W	T5 21W	T5 28W	T5 35W
2.56H, 1.63uF	15.22 W	20.56 W	28.12 W	35.32 W
3.09H, 1.565uF	15.8 W	20.83 W	27.33 W	33.78 W
4.6H, 1.347uF	14.79 W	21.61 W	28.4 W	34.16 W

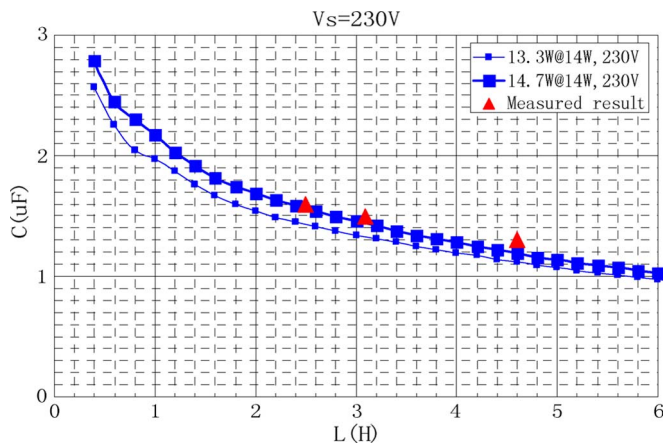

Fig. 5. Simulated lamp power curves with 5% tolerance and three lamp power measurements for T5-HE 14-W lamps.

35 W in Figs. 5–8, respectively. It can be seen that the lamp power measurements are generally consistent with the predictions. An important conclusion can now be drawn that each set of LC values can be used to power the T5 lamps from 14 to 35 W. These results confirm that a single LC set can be designed to power T5-HE lamps from 14 to 35 W.

A. ULL Ballast Design With $L = 2.56$ H and $C = 1.63 \mu\text{F}$

Based on the use of one set of LC values $L = 2.56$ H and $C = 1.63 \mu\text{F}$, the measured lamp voltage, lamp current, and lamp power are recorded for T5-HE 14-, 21-, 28-, and 35-W lamps, as shown in Figs. 9(a)–12(a), respectively. The corresponding simulated results with the same scales for each type of waveforms are included in Figs. 9(b)–12(b), respectively. It

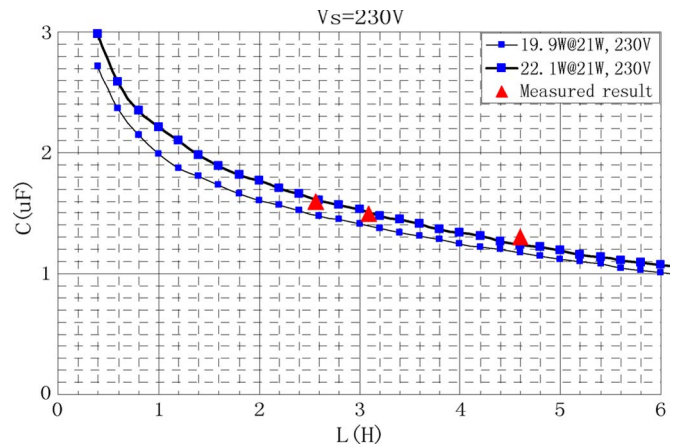

Fig. 6. Simulated lamp power curves with 5% tolerance and three lamp power measurements for T5-HE 21-W lamps.

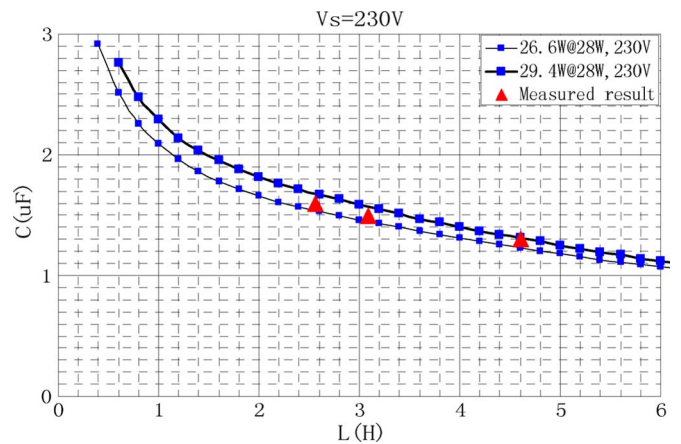

Fig. 7. Simulated lamp power curves with 5% tolerance and three lamp power measurements for T5-HE 28-W lamps.

can be seen that the physical lamp model is accurate enough to predict the lamp voltage, current, and power. The simulated lamp power and measured lamp power are highly consistent. These results confirm the fact that one ULL ballast design can be used to power T5 lamps from 14 to 35 W. It should be noted that the lamp voltage and current waveforms are typical of fluorescent lamps. The lamp power values are consistent with the respective rated power of these lamps.

It is also important to note that the current waveforms of these four types of T5-HE lamps are almost identical, as expected from T5-HE lamps that have identical current ratings according to the manufacturers’ data sheets. The difference lies in the lamp voltages, because the lamp power of T5-HE lamps is proportional to the length of the lamp tube. These practical measurements therefore confirm the discovery that one single ULL ballast design can power a range of T5-HE lamps from 14 to 35 W.

B. ULL Ballast Design With $L = 3.09$ H and $C = 1.56 \mu\text{F}$

A second set of ULL ballast with $L = 3.09$ H and $C = 1.56 \mu\text{F}$ is used to repeat the tests. The measured waveforms for T5-HE 14-, 21-, 28-, and 35-W lamps are shown in

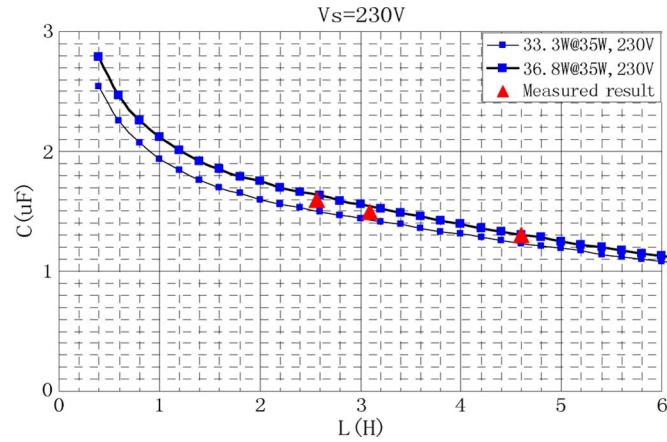

Fig. 8. Simulated lamp power curves with 5% tolerance and three lamp power measurements for T5-HE 35-W lamps.

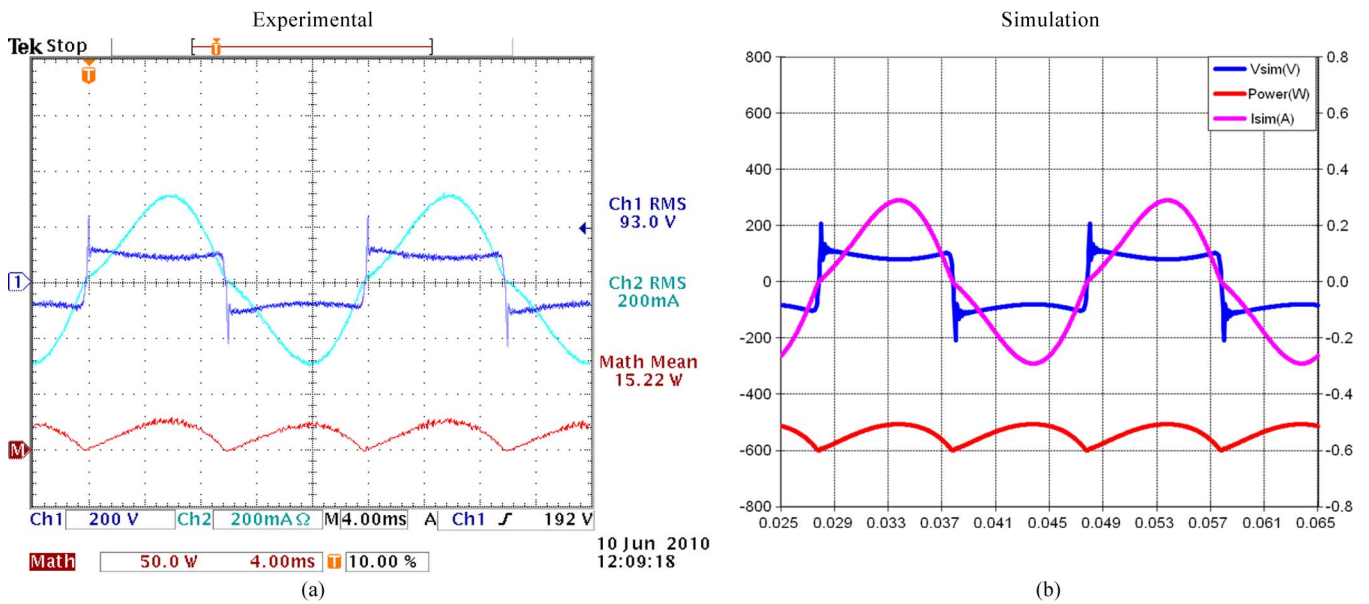

Fig. 9. (a) Measured lamp voltage, current, and power of T5 14-W lamps using a ULL ballast with $L = 2.56$ H and $C = 1.63 \mu\text{F}$. (b) Simulated lamp voltage, current, and power of T5 14-W lamps using a ULL ballast with $L = 2.56$ H and $C = 1.63 \mu\text{F}$.

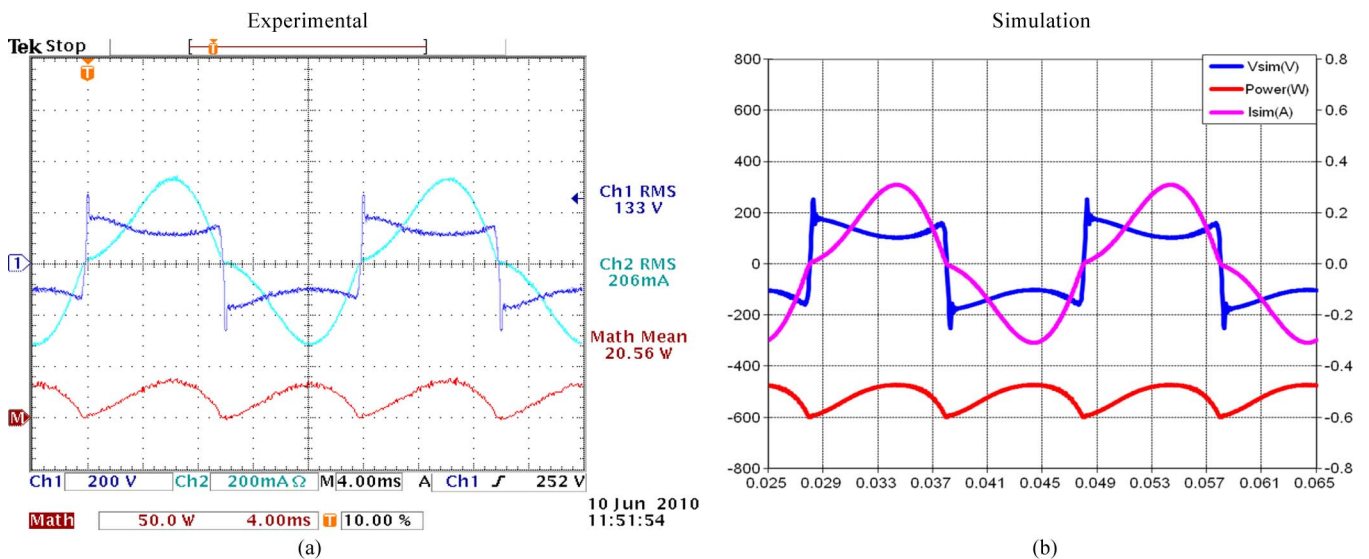

Fig. 10. (a) Measured lamp voltage, current, and power of T5 21-W lamps using a ULL ballast with $L = 2.56$ H and $C = 1.63 \mu\text{F}$. (b) Simulated lamp voltage, current, and power of T5 21-W lamps using a ULL ballast with $L = 2.56$ H and $C = 1.63 \mu\text{F}$.

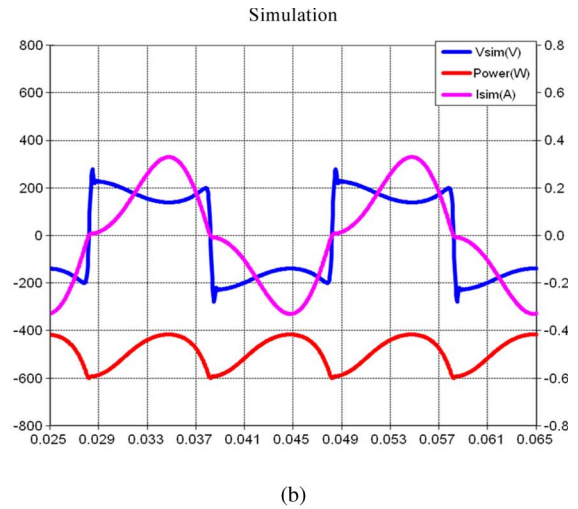
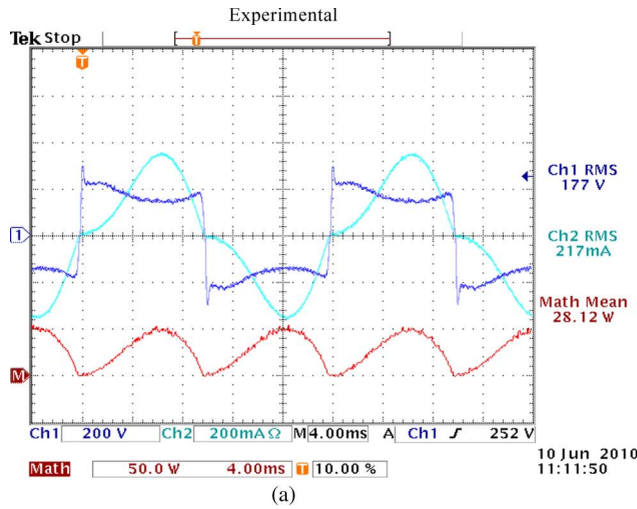

Fig. 11. (a) Measured lamp voltage, current, and power of T5 28-W lamps using a ULL ballast with $L = 2.56$ H and $C = 1.63$ μ F. (b) Simulated lamp voltage, current, and power of T5 28-W lamps using a ULL ballast with $L = 2.56$ H and $C = 1.63$ μ F.

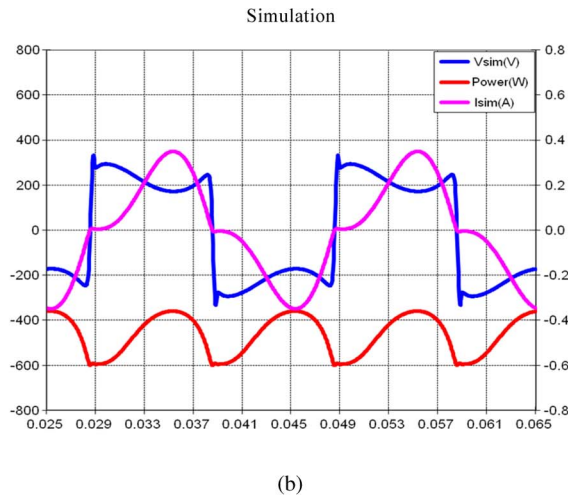
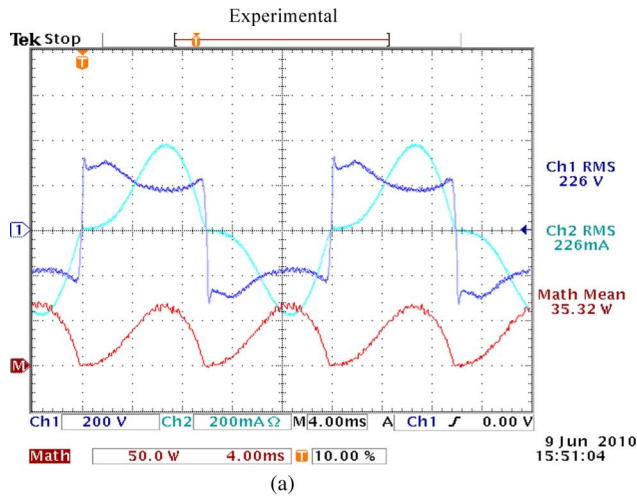

Fig. 12. (a) Measured lamp voltage, current, and power of T5 35-W lamps using a ULL ballast with $L = 2.56$ H and $C = 1.63$ μ F. (b) Simulated lamp voltage, current, and power of T5 35-W lamps using a ULL ballast with $L = 2.56$ H and $C = 1.63$ μ F.

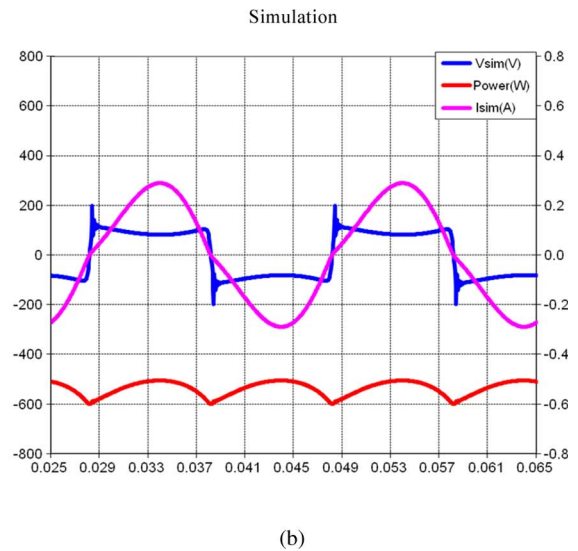
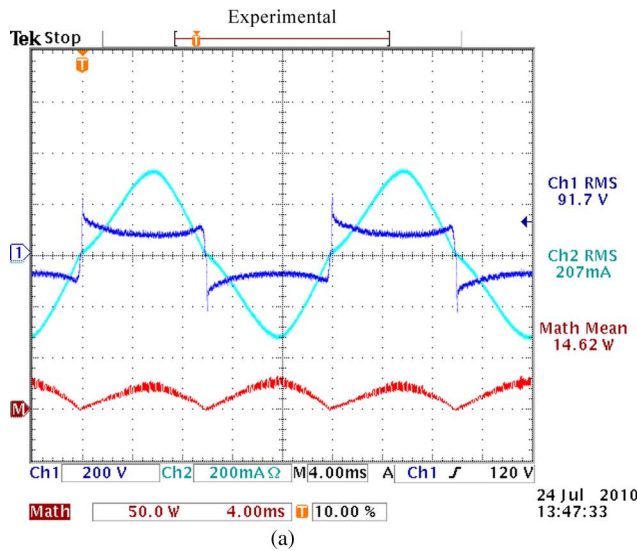

Fig. 13. (a) Measured lamp voltage, current, and power of T5 14-W lamps using a ULL ballast with $L = 3.09$ H and $C = 1.56$ μ F. (b) Simulated lamp voltage, current, and power of T5 14-W lamps using a ULL ballast with $L = 3.09$ H and $C = 1.56$ μ F.

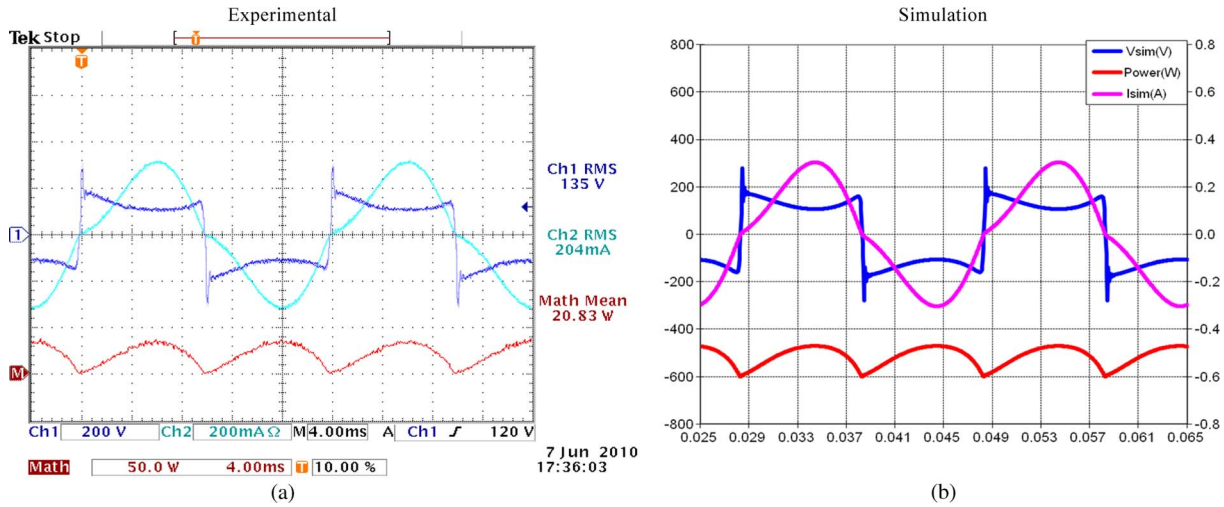

Fig. 14. (a) Measured lamp voltage, current, and power of T5 21-W lamps using a ULL ballast with $L = 3.09$ H and $C = 1.56$ μ F. (b) Simulated lamp voltage, current, and power of T5 21-W lamps using a ULL ballast with $L = 3.09$ H and $C = 1.56$ μ F.

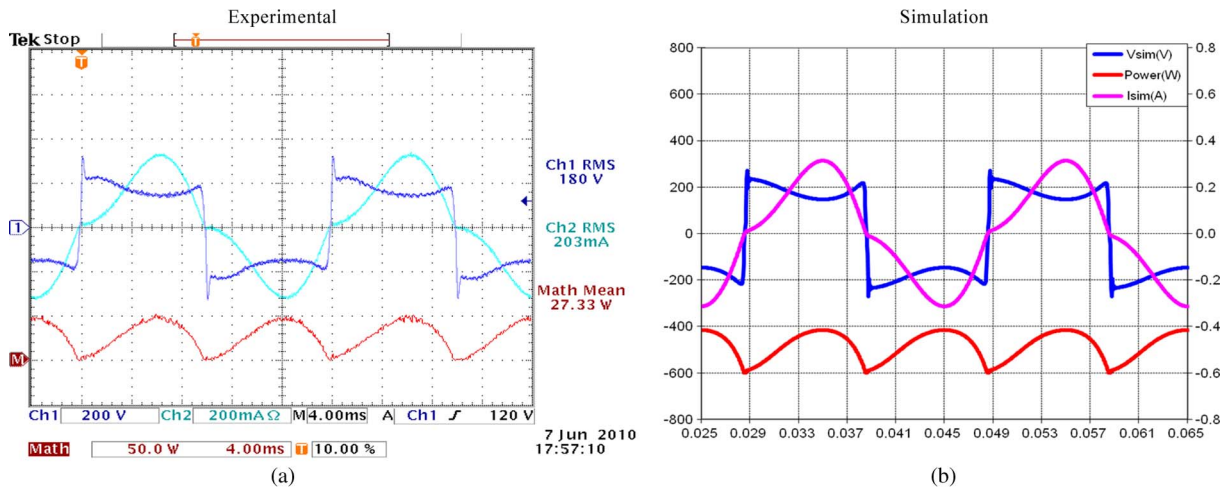

Fig. 15. (a) Measured lamp voltage, current, and power of T5 28-W lamps using a ULL ballast with $L = 3.09$ H and $C = 1.56$ μ F. (b) Simulated lamp voltage, current, and power of T5 28-W lamps using a ULL ballast with $L = 3.09$ H and $C = 1.56$ μ F.

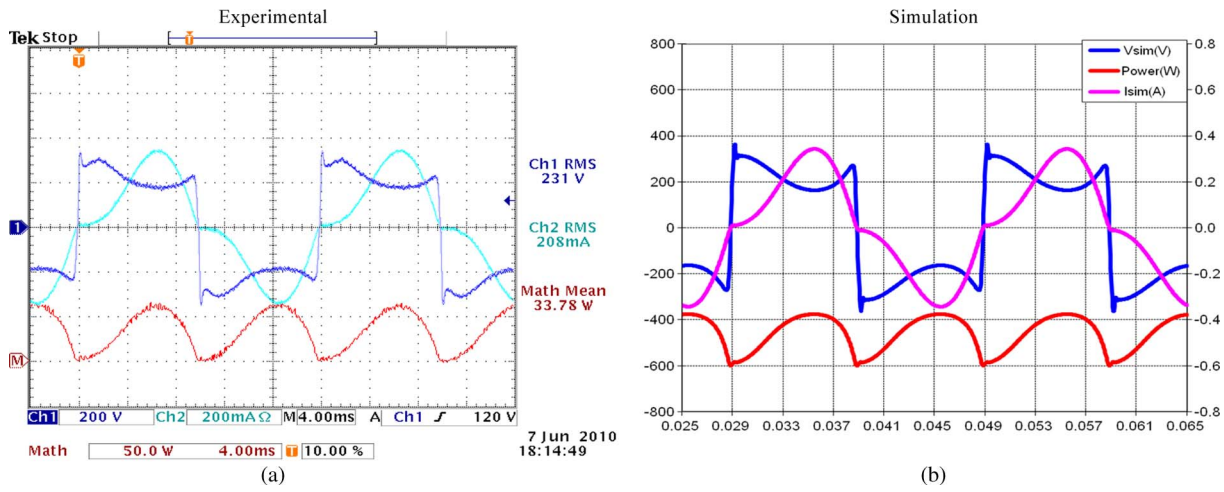

Fig. 16. (a) Measured lamp voltage, current, and power of T5 35-W lamps using a ULL ballast with $L = 3.09$ H and $C = 1.56$ μ F. (b) Simulated lamp voltage, current, and power of T5 35-W lamps using a ULL ballast with $L = 3.09$ H and $C = 1.56$ μ F.

Figs. 13(a)–16(a), respectively. The corresponding simulated waveforms are displayed in Figs. 13(b)–16(b), respectively. Again, these results confirm the accuracy of the physical lamp

model, and the argument that one ULL ballast design can be used to power a range of T5 lamps at their respective rated-power levels.

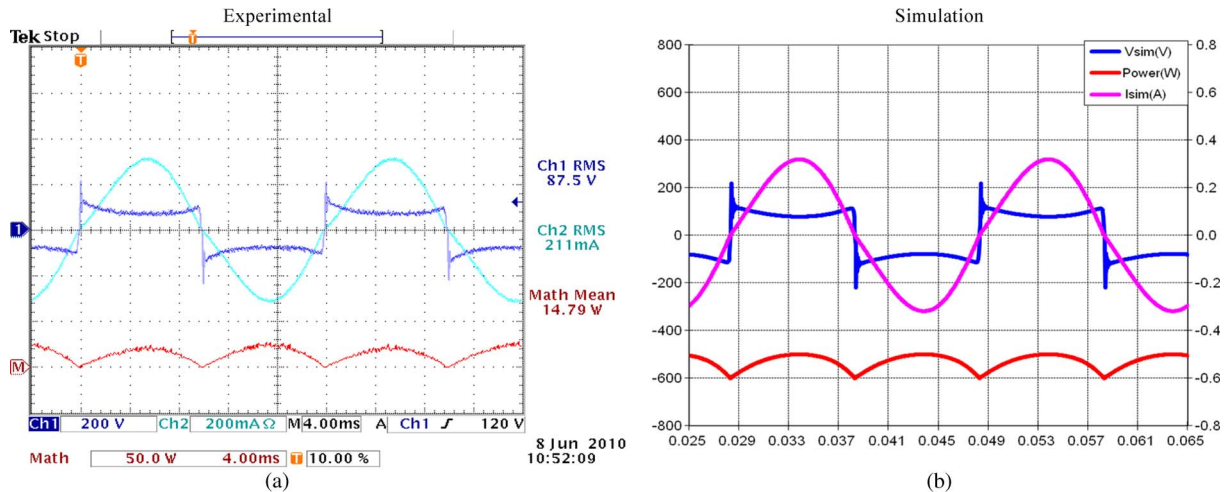

Fig. 17. (a) Measured lamp voltage, current, and power of T5 14-W lamps using a ULL ballast with $L = 4.60$ H and $C = 1.35$ μ F. (b) Simulated lamp voltage, current, and power of T5 14-W lamps using a ULL ballast with $L = 4.60$ H and $C = 1.35$ μ F.

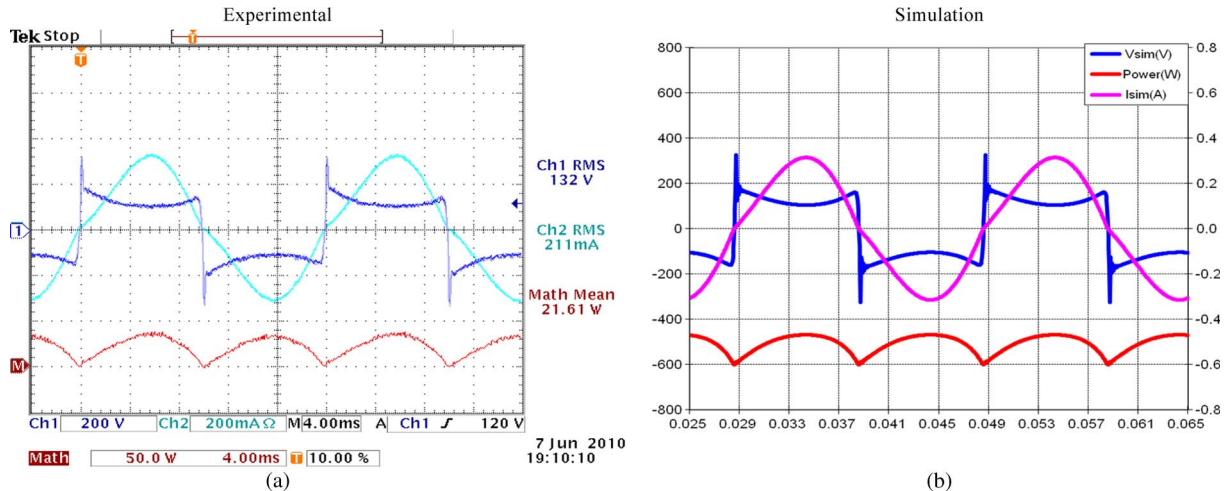

Fig. 18. (a) Measured lamp voltage, current, and power of T5 21-W lamps using a ULL ballast with $L = 4.60$ H and $C = 1.35$ μ F. (b) Simulated lamp voltage, current, and power of T5 21-W lamps using a ULL ballast with $L = 4.60$ H and $C = 1.35$ μ F.

C. ULL Ballast Design With $L = 4.60$ H and $C = 1.35$ μ F

In order to strengthen the point that any set of inductor and capacitor values within the predicted region of Fig. 3 can be used to drive a range of T5 lamps in their rated power, the third ULL ballast with $L = 4.60$ H and $C = 1.35$ μ F is used for further evaluation. The measured waveforms are displayed in Figs. 17(a)–20(a) for T5-HE 14-, 21-, 28-, and 35-W lamps, respectively. The corresponding simulations in Figs. 17(b)–20(b) once more confirm the model accuracy and the use of a single ULL ballast design for a range of T5 lamps.

The simulations and measurements obtained from these three ULL ballasts indicate that, as long as the LC values are chosen within the predicted region in Fig. 3, a single ULL ballast design can be used to drive for T5 lamps from 14 to 35 W at their rated-power levels. This unique feature of T5 lamps enables ballast manufacturers to design one ULL ballast product for a range of T5 lamps. This new feature is very advantageous to the ULL ballasts, because electronic ballasts are usually designed for specific lamp power. In practice, one may choose a small

inductor value according to the predicted region in Fig. 3 in order to reduce the size of the inductor and its associated costs.

ULL ballasts are more simple and reliable than electronic ballasts. It has been proven that they can meet the A2 Class, which is the most energy efficient category for nondimmable ballasts [11]. In addition, the majority of their product materials such as magnetic cores and copper windings can be recycled at the end of their lifetime. Therefore, it is envisaged that the ULL ballasts can offer a genuine sustainable lighting solution to the lighting industry. The filament heating [15], which is a topic outside the scope of this paper, can be handled by customized electronic starter for T5 lamps [10]. Without high-frequency switching, the ULL ballast will not cause electromagnetic interference with radio-frequency identification systems [16].

V. CONCLUSION

In this paper, the concept of using one set of LC values for the ULL ballast to drive T5-HE lamps of 14, 21, 28, and

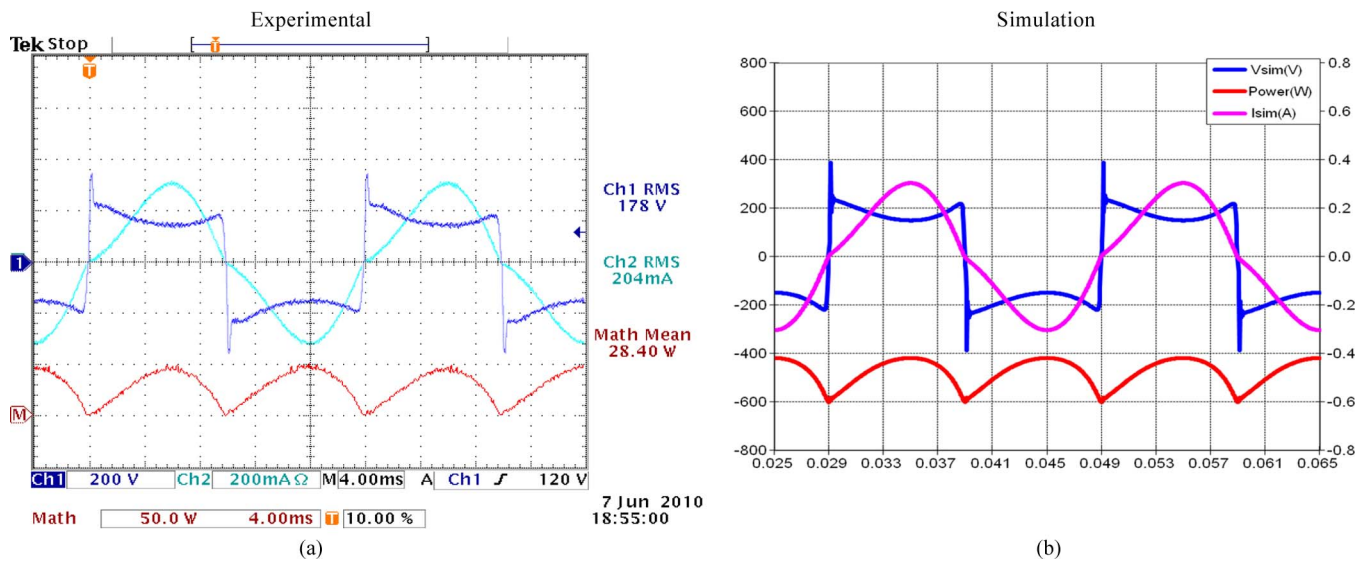

Fig. 19. (a) Measured lamp voltage, current, and power of T5 28-W lamps using a ULL ballast with $L = 4.60$ H and $C = 1.35$ μ F. (b) Simulated lamp voltage, current and power of T5-28 W lamps using a ULL ballast with $L = 4.60$ H and $C = 1.35$ μ F.

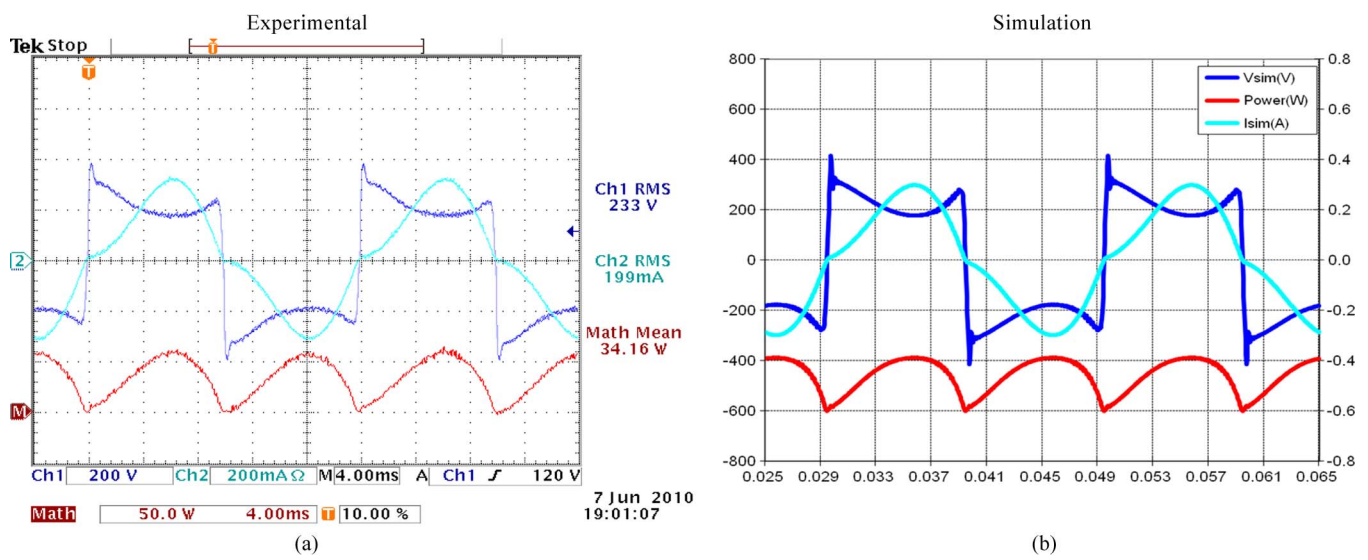

Fig. 20. (a) Measured lamp voltage, current and power of T5-35 W lamps using a ULL ballast with $L = 4.60$ H and $C = 1.35$ μ F. (b) Simulated lamp voltage, current, and power of T5 35-W lamps using a ULL ballast with $L = 4.60$ H and $C = 1.35$ μ F.

35 W at their respective rated power has been theoretically developed and practically confirmed. This new discovery enables a universal ULL ballast design for a wide range of T5-HE lamps, making such design attractive in the manufacturing process. As previously confirmed [11], the ULL ballasts are as energy efficient as electronic ballasts. Without using an electrolytic capacitor and with the use of simple and passive components, they are expected to have much longer lifetime than their electronic counterparts. Since the inductor core and winding can be recycled at the end of the product lifetime, the ULL ballast technology for T5 lamps is a sustainable lighting technology that has the potential of outperforming existing electronic ballast technology in terms of energy saving, long lifetime, and recyclability. The appropriate choice of the LC values depends on a combination of factors such as the size, cost, and power losses of the inductor. The ballast manufac-

turers should make decisions according to the applications and design constraints.

REFERENCES

- [1] R. S. Simpson, *Light Control: Technology & Applications*, 7th ed. South Strathfield, Australia: Focus Press, 2003.
- [2] M. Alonso, "Electronic Ballasts," in *Power Electronics Handbook*, M. H. Rashid, Ed. New York: Academic, 2007, ch. 22.
- [3] P. T. Krein and R. S. Balog, "Cost-effective hundred-year life for single-phase inverters and rectifiers in solar and IED lighting applications based on minimum capacitance requirements and a ripple power port," in *Proc. IEEE Appl. Power Electron. Conf.*, Feb. 15–19, 2009, pp. 620–625.
- [4] G. Linlin, R. Xinbo, X. Ming, and Y. Kai, "Means of eliminating electrolytic capacitor in ac/dc power supplies for LED lightings," *IEEE Trans. Power Electron.*, vol. 24, no. 5, pp. 1399–1408, May 2009.
- [5] Y. X. Qin, H. S. H. Chung, D. Y. Lin, and S. Y. R. Hui, "Current source ballast for high power lighting emitting diodes without electrolytic capacitor," in *Proc. 34th Annu. Conf. IEEE IECON*, 2008, pp. 1968–1973.

- [6] A. Leung, W. Luksemburg, A. Wong, and M. Wong, "Spatial distribution of polybrominated diphenyl ethers and polychlorinated dibenzo- p-dioxins and dibenzofurans in soil and combusted residue at guiyu, an electronic waste recycling site in southeast China," *Environ. Sci. Technol.*, vol. 41, no. 8, pp. 2730–2737, Apr. 2007.
- [7] C. S. C. Wong, N. S. Duzgoren-Aydin, A. Aydin, and M. H. Wong, "Evidence of excessive releases of metals from primitive e-waste processing in Guiyu, China," *Environ. Pollut.*, vol. 148, no. 1, pp. 62–72, Jul. 2007.
- [8] Federation of National Manufacturers Associations for Luminaires and Electrotechnical Components for Luminaires in the European Union (CELMA), Guide for the Application of Directive 2000/55/EC on Energy Efficiency for Ballasts for Fluorescent Lighting, Annex III, Issue 3.1, p. 14, Jul. 2007.
- [9] D. E. Rothenbuhler, S. A. Johnson, G. A. Noble, and J. P. Seubert, "Preheating and starting circuit and method for a fluorescent lamp," U.S. Patent 5 736 817, Apr. 7, 1998.
- [10] D. E. Rothenbuhler and S. A. Johnson, "Resonant voltage multiplication, current-regulating and ignition circuit for a fluorescent lamps," U.S. Patent 5 708 330, Jan. 13, 1998.
- [11] S. Y. R. Hui, D. Y. Lin, W. M. Ng, and W. Yan, "A 'Class-A2' ultra-low-loss magnetic ballast for T5 fluorescent lamps," in *IEEE Trans. Power Electron.*, Feb. 2011, vol. 26, no. 2, pp. 622–629.
- [12] D. Lin, W. Yan, G. Zissis, and S. Y. R. Hui, "A simple physical low pressure discharge lamp model," in *Proc. IEEE ECCE.*, 2009, pp. 2051–2058.
- [13] Y. Wei, E. Tam, and S. Y. Hui, "A semi-theoretical fluorescent lamp model for time-domain transient and steady-state simulations," *IEEE Trans. Power Electron.*, vol. 22, no. 6, pp. 2106–2115, Nov. 2007.
- [14] S. Y. R. Hui, W. M. Ng, and D. Y. Lin, "A passive LC ballast and method of manufacturing a passive LC ballast," Patent application number: PCT/IB2009/007 289, Nov. 3, 2009.
- [15] S. Ben Yaakov, M. Shvartsas, and G. Ivensky, "HF multiresonant electronic ballast for fluorescent lamps with constant filament preheat voltage," *IEEE Trans. Ind. Appl.*, vol. 44, no. 1, pp. 61–67, Jan./Feb. 2008.
- [16] G. Ibrahim and A. Plytage, "UHF RFID systems; Their susceptibility to backscattered signals induced by electronic ballast driven fluorescent lamps," *IEEE Trans. Antennas Propag.*, vol. 58, no. 7, pp. 2473–2478, Jul. 2010.
- [17] W. M. Ng, D. Y. Lin, and S. Y. R. Hui, "A single eco-friendly ultra-low-loss magnetic ballast for a wide range of T5 high-efficient fluorescent lamps," in *Proc. IEEE Energy Convers. Conf. Expo.*, 2010, pp. 1321–1326.
- [18] R. Orletti, M. A. Co, D. S. L. Simonetti, and J. L. de Freitas Vieira, "HID lamp electronic ballast with reduced component number," *IEEE Trans. Ind. Electron.*, vol. 56, no. 3, pp. 718–725, Mar. 2009.
- [19] W. Yan, S. Y. Hui, and H. S.-H. Chung, "Energy saving of large-scale high-intensity-discharge lamp lighting networks using a central reactive power control sys," *IEEE Trans. Ind. Electron.*, vol. 56, no. 8, pp. 3069–3078, Aug. 2009.
- [20] S.-C. Tan, "General n-level driving approach for improving electrical-to-optical energy-conversion efficiency of fast-response saturable lighting devices," *IEEE Trans. Ind. Electron.*, vol. 57, no. 4, pp. 1342–1353, Apr. 2010.



W. M. Ng (M'04) received the B.Eng. and M.Phil degrees in electronic engineering from City University of Hong Kong, Kowloon, Hong Kong, in 1998 and 2004, respectively.

He is currently a Research Fellow with the Department of Electrical and Electronic Engineering, The University of Hong Kong and is also a Ph.D. research student at the University of Hong Kong. His research interests include a dc–dc converter, gas discharge modeling and applications, computer-aided simulation techniques, lighting science, and

sustainable lighting technology.



Deyan Y. Lin (M'09) was born in China in 1972. He received the B.Sc. and M.A.Sc. degrees in electrical engineering from Huazhong University of Science and Technology, Wuhan, China, in 1995 and 2004, respectively. He is currently working toward the Ph.D. degree with the Department of Electronic Engineering, City University of Hong Kong, Kowloon, Hong Kong.

From 1995 to 1999, he was an Assistant with the Department of Electrical Engineering, Jiangnan University, Wuhan, where he became a Lecturer later.

Since 2008, he has been a Senior Research Assistant with the City University of Hong Kong. His current research interests include modeling, control, and simulation of gas-discharge lamps.

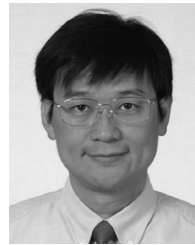

S. Y. (Ron) Hui (F'03) received the B.Sc. (Eng.) Hons from the University of Birmingham, Birmingham, U.K., in 1984 and the D.I.C. and Ph.D. degrees from Imperial College of Science and Technology, London, U.K., in 1987.

From 1987 to 1990, he was a Lecturer with the University of Nottingham, Nottingham, U.K. In 1990, he joined the University of Technology, Sydney, Australia. In 1992, he was appointed Senior Lecturer at the University of Sydney, Sydney, where he became a Reader in 1995. He joined the City University of Hong Kong (CityU), Kowloon, Hong Kong, as a Professor, in 1996, and was promoted to Chair Professor in 1998. From 2001 to 2004, he was an Associate Dean of the Faculty of Science and Engineering, CityU. Since July 2011, he has held Chair Professorships with both the Department of Electrical and Electronic Engineering, The University of Hong Kong, and the Department of Electrical and Electronic Engineering, Imperial College London, London. He has authored more than 200 technical papers, including more than 150 refereed journal publications and book chapters. He is the holder of more than 50 patents, which have been adopted by the industry.

Dr. Hui is a Fellow of the Institution of Engineering and Technology (IET). He has been an Associate Editor for the IEEE TRANSACTIONS ON POWER ELECTRONICS since 1997 and an Associate for the IEEE TRANSACTIONS ON INDUSTRIAL ELECTRONICS since 2007. He has been appointed twice as an IEEE Distinguished Lecturer by the IEEE Power Electronics Society in 2004 and 2006. He served as one of the 18 Administrative Committee members of the IEEE Power Electronics Society and was the Chairman of its Constitution and By-Laws Committee from 2002 to 2010. He was the recipient of the Teaching Excellence Award at CityU in 1998, Earth Champion Award in 2008, IEEE Best Paper Award from the IEEE IAS Committee on Production and Applications of Light in 2002, two IEEE Power Electronics Transactions Prize Paper Awards for his publication in Wireless Battery Charging Platform Technology in 2009 and for his paper on LED system theory in 2010, and the IEEE Rudolf Chope R&D Award from the IEEE Industrial Electronics Society and the IET Achievement Medal (The Crompton Medal) in November 2010. He was elected to the Fellowship of the Australian Academy of Technological Sciences and Engineering in November 2010. His inventions on wireless charging platform technology underpin key dimensions of Qi, which is the world's first wireless power standard, with freedom of positioning and localized charging features.