



Title	High-sensitivity optical preamplifier for WDM systems using an optical parametric amplifier
Author(s)	Liang, Y; Li, J; Chui, PC; Wong, KKY
Citation	IEEE Photonics Technology Letters, 2009, v. 21 n. 20, p. 1562-1564
Issued Date	2009
URL	http://hdl.handle.net/10722/155574
Rights	Creative Commons: Attribution 3.0 Hong Kong License

High-Sensitivity Optical Pre-amplifier for WDM Systems Using an Optical Parametric Amplifier

Yu Liang, Jia Li, P. C. Chui, and Kenneth K. Y. Wong, *Member, IEEE*

Abstract—We propose and demonstrate a novel pre-amplifier to improve receiver sensitivity for a 10-Gb/s return-to-zero on-off keying format by using a fiber optical parametric amplifier. Receiver sensitivity can reach down to -42 dBm at bit-error rate $= 10^{-9}$. This sensitivity is only 1.1 dB off the quantum limit. The crosstalk issue is also investigated for this dual-end detection scheme in a wavelength-division-multiplexing system.

Index Terms—Optical parametric amplifier (OPA), pre-amplifier, receiver sensitivity.

I. INTRODUCTION

PREAMPLIFICATION is an enabling technology for optical communication. It can extend system span and reduce the cost effectively in long-haul lightwave systems by improving the receiver sensitivity. Currently, erbium-doped fiber amplifier (EDFA) has been widely employed in receivers due to technological maturity. Previous experiments have demonstrated that optical pre-amplifiers can achieve low receiver sensitivities of -37.2 dBm with 33-dB gain [1] and -38.8 dBm with 46-dB gain [2] at 10 Gb/s. These techniques are also employed in wavelength-division-multiplexing (WDM) systems which are prevalent today. On the other hand, fiber-based optical parametric amplifier (OPA) with femtosecond response time [3], high gain [4] and wide gain bandwidth [5], has been demonstrated to be a candidate as a pre-amplifier [6] and amplifier in WDM systems [7]. Therefore, in this letter, we propose and demonstrate a novel pre-amplifier to improve receiver sensitivity by using dual-end detection (i.e., signal plus idler) of OPA for return-to-zero on-off keying (RZ-OOK) WDM systems.

II. PRINCIPLE AND EXPERIMENTAL SETUP

The principle of pre-amplifier based on OPA is shown in Fig. 1. By launching a weak RZ-OOK signal together with a strong pump into nonlinear medium, both the amplification of the weak signal and the generation of a new component called idler will occur by extracting power from the strong pump. As a result, the pattern on signal can be transcribed to the idler, while the pump will be depleted simultaneously. By feeding both

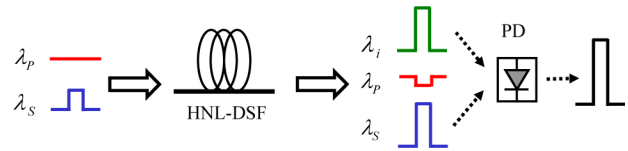

Fig. 1. Principle of proposed pre-amplifier.

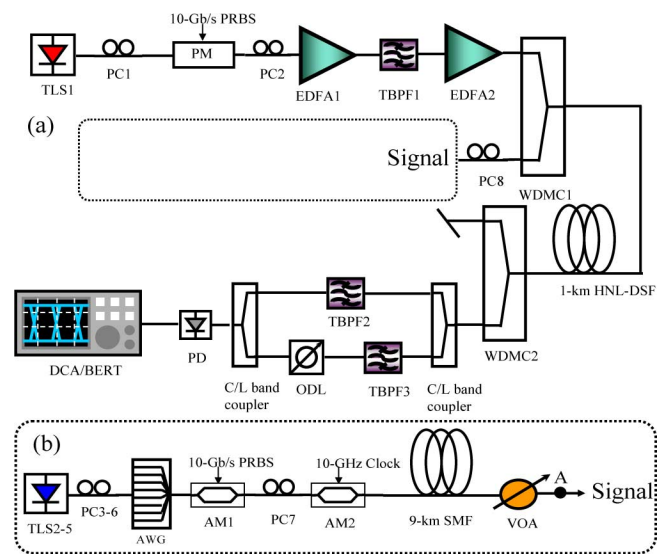

Fig. 2. Experimental setup of (a) pre-amplifier and (b) four WDM channels transmitter.

the amplified signal and the idler into a photodetector (PD), constructive superposition can enhance the amplitude of output. Therefore, an output electrical signal with higher voltage swing is obtained. By implementing this dual-end detection scheme in each channel of WDM systems, extra amplification can be obtained.

The experimental setup is shown in Fig. 2, with part (a) as the pre-amplifier. The nonlinear medium used for OPA is a spool of 1-km highly nonlinear dispersion-shifted fiber (HNL-DSF) with a nonlinear coefficient $\gamma \approx 14 \text{ W}^{-1} \cdot \text{km}^{-1}$ and zero-dispersion wavelength $\lambda_0 \approx 1560$ nm. The OPA pump is supplied from a tunable laser source (TLS1) with emission wavelength at 1561.1 nm. It is phase-modulated with 10-Gb/s $2^{31} - 1$ pseudorandom binary sequence (PRBS) for stimulated Brillouin scattering (SBS) suppression. The phase-dithered pump is then amplified by two EDFAs (EDFA1 and EDFA2) to 27.7 dBm with a tunable bandpass filter (TBPF1) between them to reduce the amplified spontaneous emission (ASE) noise before entering into EDFA2. In Fig. 2(b), the dashed line box shows the signal part. Four signal laser sources (TLS2-5)

Manuscript received May 14, 2009; revised July 18, 2009. First published August 25, 2009; current version published October 02, 2009. This work was supported in part by a grant from the Research Grants Council of the Hong Kong Special Administrative Region, China (Projects HKU 7172/07E and HKU 7179/08E).

The authors are with the Photonic Systems Research Laboratory, Department of Electrical and Electronic Engineering, The University of Hong Kong, Hong Kong, China (e-mail: yliang@eee.hku.hk; jiali@eee.hku.hk; pcchui@eee.hku.hk; kywong@eee.hku.hk).

Color versions of one or more of the figures in this letter are available online at <http://ieeexplore.ieee.org>.

Digital Object Identifier 10.1109/LPT.2009.2030507

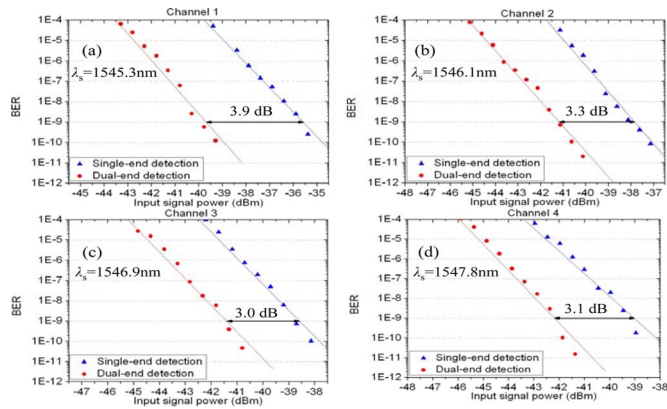

Fig. 3. BER plots of (a) channel 1, (b) channel 2, (c) channel 3, and (d) channel 4.

with wavelengths from 1545.3 to 1547.8 nm are combined by an arrayed waveguide grating (AWG) with channel spacing of 100 GHz. Then the four lightwaves are intensity-modulated by two Mach-Zehnder intensity modulators (MZ-IM) with 10-Gb/s $2^{31} - 1$ PRBS and 10-GHz clock, respectively, to carve RZ-OOK format. A spool of 9-km single-mode fiber (SMF) is used to decorrelate the four channels. The pump and signals are combined using a WDM coupler (WDMC1) and launched into HNL-DSF for parametric amplification. Maximum OPA gain is attained by aligning the state of polarizations (SOPs) of signals and pump through polarization controllers PC2 and PC8. Then the pump is filtered out by WDMC2. The signals and idlers are split by a C/L -band coupler, while the corresponding signal and idler are filtered by TBPF2 and TBPF3 with 0.2-nm bandwidth. In addition, the path length difference is compensated by an optical delay line (ODL). The two paths are combined again using another C/L -band coupler. The output is monitored through a bit-error-rate tester (BERT) with 10-GHz bandwidth PD (Agilent 83434A). The input signal power is measured at the input port of PC8 (denoted as point A in Fig. 2) and controlled by a variable optical attenuator (VOA) for bit-error-rate (BER) measurement. The input loss, including PC8, WDMC1, and fusion splices, is 0.6 dB. The insertion losses between output of HNL-DSF and PD of signal and idler branches are 9 and 7.2 dB. These losses are comparable with the corresponding loss of EDFAs [1], [2].

III. RESULTS

In order to quantify the benefit of dual-end detection, BER of single- and dual-end detection schemes for four 10-Gb/s RZ-OOK WDM channels are measured and shown in Fig. 3. From channels 1 to 4 at wavelengths 1545.3 to 1547.8 nm with 100-GHz spacing, their receiver sensitivities at $\text{BER} = 10^{-9}$ can achieve -35.6 , -37.8 , -38.5 , and -38.9 dBm by single-end detection using only amplified signals. Their differences can be explained by the different parametric gain experienced by each channel, as shown in Fig. 4, which shows the spectra at the output of the 1-km HNL-DSF. The internal parametric gains experienced by the four channels are 33, 35, 37, and 37 dB, respectively, which

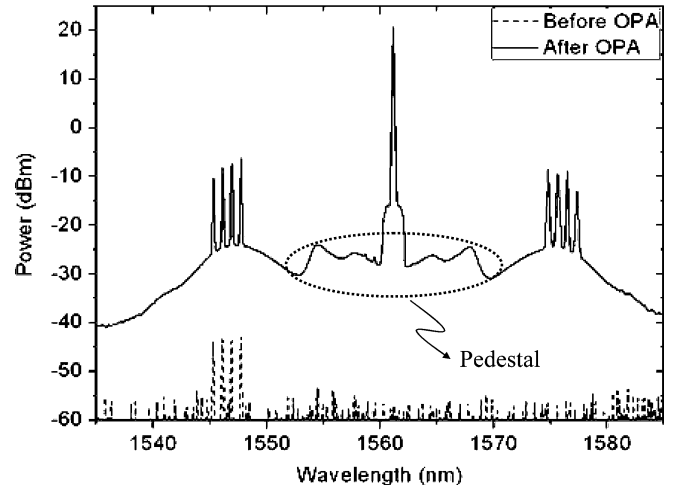

Fig. 4. Spectra before and after OPA at the output of HNL-DSF.

can be measured from the spectra as shown in Fig. 4. In other words, the channel in the high-gain region can achieve lower sensitivity. These single-end sensitivities are better than [6]. Note that the passband of WDMC1 for the pump branch is from 1554.8 to 1563.4 nm, which carves ASE noise to form the pedestal at the bottom of pump in Fig. 4. Using the dual-end detection scheme, the receiver sensitivities can achieve -39.5 , -41.1 , -41.5 , and -42 dBm, respectively. They are even lower than [1] and [2]. The sensitivity of channel 4 is only 1.1 dB off the quantum limit of -43.1 dBm [8]. However, the single-end detection sensitivities are still at least 4.2 dB away from the theoretical limit. Therefore, performance is dominated by ASE noise and receiver electronic noise other than signal photon number fluctuations. When the idler is added and the input signal power is reduced, the noise level is not greatly affected. The electrical output power from PD and the dominant noise are unchanged. Hence, BER can be maintained and sensitivities can be improved. More than 3-dB improvements are measured because of the different insertion losses of signal and idler branches. The net black box gain of idler is 1.8 dB higher than that of the signal. It indicates that the sensitivity of the idler is lower than that of the signal at the same input signal power.

Four-wave mixing (FWM) and cross-gain modulation (XGM) are two distinct effects limiting the deployment of fiber OPA in WDM systems. When the channels copropagate through the nonlinear gain medium of OPA, the signal-signal FWM and spurious FWM tones will occur [9]. XGM will induce different instantaneous parametric gain for each channel in a WDM system if the total output signal power is high. These effects will degrade the performance of using OPA as preamplifiers and can be reflected by BER curve and receiver sensitivity. For preamplification, each channel exhibits fairly low input power, which makes XGM effects insignificant [10]. In order to investigate the FWM-induced crosstalk, the FWM-tones are measured with one signal channel switched OFF in each measurement. The spectra of output signals with channels 1 to 4 switched OFF in sequence are shown in Fig. 5. The total input power is controlled by VOA so that channel 1 (worst) can reach $\text{BER} = 10^{-9}$ while other channels are below 10^{-9} of BER.

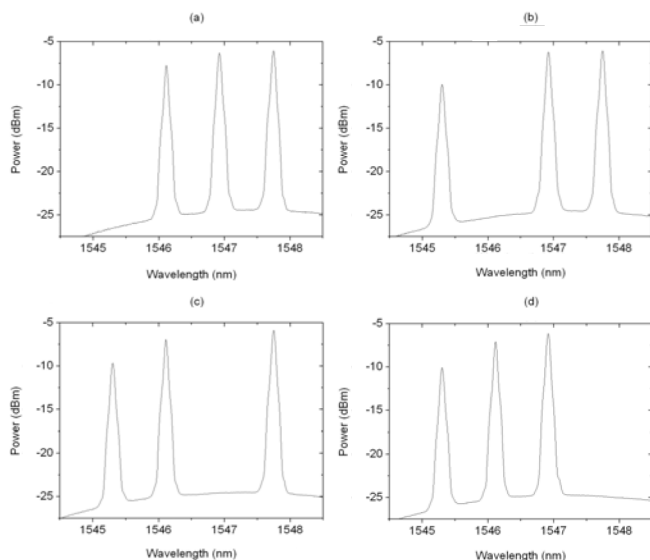

Fig. 5. Spectra of post-OPA signals with (a) channel 1 OFF, (b) channel 2 OFF, (c) channel 3 OFF, and (d) channel 4 OFF.

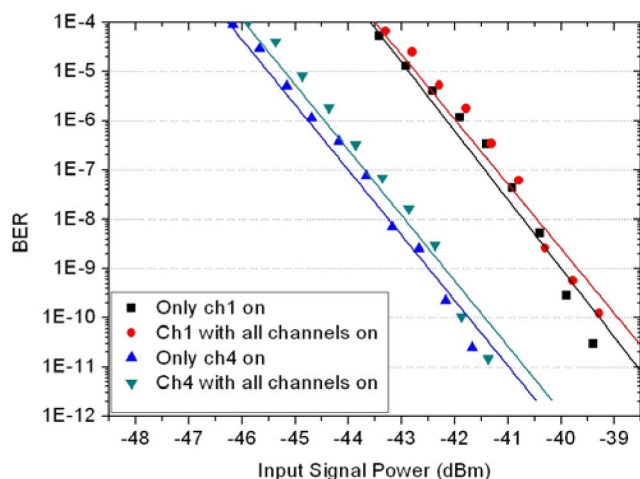

Fig. 6. BER of channel 1 and 4 with other channels ON and OFF.

The FWM-tones are not observable for all channels in Fig. 5. It shows that the FWM-tones are at least 15–20 dB lower than signals and cannot induce crosstalk using such low input power. The same measurement is implemented amongst idlers and no FWM-tone can be observed. Comparisons of channel 1 (worst) and channel 4 (best) with other channels switched ON and OFF are investigated in terms of receiver sensitivity. In Fig. 6, channels 1 and 4 are degraded by only 0.3 dB at $\text{BER} = 10^{-9}$ when the other WDM channels are switched ON compared to

the receiver sensitivities when only channel 1 or 4 is switched ON. This indicates that the multichannel preamplification is not affected by the crosstalk from other WDM channels and its performance is comparable to single-channel amplification.

IV. CONCLUSION

We demonstrated a novel receiver sensitivity improvement scheme for a 10-Gb/s RZ-OOK signal using constructive superposition of signals and idlers in OPA for WDM systems by dual-end detection. Receiver sensitivity down to -42 dBm was realized which was only 1.1 dB above the quantum limit. Crosstalk due to FWM and XGM were not observable. This scheme would be useful for improving performance of OPA-assisted receivers in WDM systems.

ACKNOWLEDGMENT

The authors would like to acknowledge Prof. M. E. Marhic for fruitful discussion and Sumitomo Electric Industries for providing the HNL-DSF.

REFERENCES

- [1] T. Saito, Y. Sunohara, K. Fukagai, S. Ishikawa, N. Henmi, S. Fujita, and Y. Aoki, "High receiver sensitivity at 10 Gb/s using an Er-doped fiber preamplifier pumped with a 0.98 μm laser diode," *IEEE Photon. Technol. Lett.*, vol. 3, no. 6, pp. 551–553, Jun. 1991.
- [2] R. I. Laming, A. H. Gnauck, C. R. Giles, M. N. Zervas, and D. N. Payne, "High-sensitivity two-stage erbium-doped fiber preamplifier at 10 Gb/s," *IEEE Photon. Technol. Lett.*, vol. 4, no. 12, pp. 1348–1350, Dec. 1992.
- [3] M. E. Marhic, *Fiber Optical Parametric Amplifiers, Oscillators and Related Devices*. Cambridge, U.K.: Cambridge Univ. Press, 2007.
- [4] T. Torounidis, P. A. Andrekson, and B. E. Olsson, "Fiber-optical parametric amplifier with 70-dB gain," *IEEE Photon. Technol. Lett.*, vol. 18, no. 10, pp. 1194–1196, May 15, 2006.
- [5] M. E. Marhic, K. K. Y. Wong, and L. G. Kazovsky, "Wide-band tuning of the gain spectrum of one-pump fiber optical parametric amplifiers," *IEEE J. Sel. Topics Quantum Electron.*, vol. 10, no. 5, pp. 1133–1141, Sep./Oct. 2004.
- [6] J. Hansryd and P. A. Andrekson, "Broad-band continuous-wave-pumped fiber optical parametric amplifier with 49-dB gain and wavelength—Conversion efficiency," *IEEE Photon. Technol. Lett.*, vol. 13, no. 3, pp. 194–196, Mar. 2001.
- [7] T. Torounidis, H. Sunnerud, P. O. Hedekvist, and P. A. Andrekson, "Amplification of WDM signals in fiber-based optical parametric amplifiers," *IEEE Photon. Technol. Lett.*, vol. 15, no. 8, pp. 1061–1063, Aug. 2003.
- [8] P. S. Henry, "Error-rate performance of optical amplifiers," in *Proc. OFC'89*, Houston, TX, 1989, Paper ThK3.
- [9] F. Forghieri, R. W. Tkach, and A. R. Chraplyvy, I. P. Kaminow and T. L. Koch, Eds., "Fiber nonlinearities and their impact on transmission systems," in *Optical Fiber Telecommunications IIIA*. San Diego, CA: Academic, 1997.
- [10] J. M. C. Boggio, E. A. M. Fagotto, M. E. Marhic, F. A. Callegari, and H. L. Fragnito, "Amplification of 12 \times 10 Gb/s WDM signals with negligible FWM crosstalk in a double-pumped fiber optical parametric amplifier," *Opt. Commun.*, vol. 280, no. 2, pp. 468–471, 2007.