



Title	Fast and wide tuning wavelength-swept source based on dispersion-tuned fiber optical parametric oscillator
Author(s)	Zhou, Y; Cheung, KKY; Li, Q; Yang, S; Chui, PC; Wong, KKY
Citation	Optics Letters, 2010, v. 35 n. 14, p. 2427-2429
Issued Date	2010
URL	http://hdl.handle.net/10722/135102
Rights	Creative Commons: Attribution 3.0 Hong Kong License

Fast and wide tuning wavelength-swept source based on dispersion-tuned fiber optical parametric oscillator

Yue Zhou,¹ Kim K. Y. Cheung,¹ Qin Li,¹ Sigang Yang,¹ P. C. Chui,¹ and Kenneth K. Y. Wong^{1,2,*}

¹Department of Electrical and Electronic Engineering, The University of Hong Kong, Pokfulam Road, Hong Kong

²At present on leave at the Massachusetts Institute of Technology, Cambridge, Massachusetts, USA.

*Corresponding author: kywong@eee.hku.hk

Received May 10, 2010; revised June 23, 2010; accepted June 23, 2010;

posted June 29, 2010 (Doc. ID 128221); published July 12, 2010

We demonstrate a dispersion-tuned fiber optical parametric oscillator (FOPO)-based swept source with a sweep rate of 40 kHz and a wavelength tuning range of 109 nm around 1550 nm. The cumulative speed exceeds 4,000,000 nm/s. The FOPO is pumped by a sinusoidally modulated pump, which is driven by a clock sweeping linearly from 1 to 1.0006 GHz. A spool of dispersion-compensating fiber is added inside the cavity to perform dispersion tuning. The instantaneous linewidth is 0.8 nm without the use of any wavelength selective element inside the cavity. 1 GHz pulses with pulse width of 150 ps are generated. © 2010 Optical Society of America

OCIS codes: 060.2320, 060.4370, 190.4380.

Wavelength-swept sources play important roles in biomedical imaging [1] and sensing applications [2]. A desirable wavelength-swept source has features such as a wide wavelength range, fast sweep rate, high linearity, and narrow linewidth in order to capture maximal interferometric information or enhance the spatial resolution. Previous efforts on wavelength-swept sources have been demonstrated in erbium-doped fiber lasers [3], semiconductor lasers, and optical parametric oscillators [4]. However, most of the time these techniques can only operate at certain wavelength ranges [3] or the setup is complicated and requires a dedicated alignment of optimal operation. On the other hand, fiber optical parametric oscillators (FOPOs) [5–8] eliminate the need for alignment and allow swept signal generation in potential regions where a practical gain medium may not yet be available. Using the FOPO configuration, a wavelength-swept source has been demonstrated with a 329 nm tuning range, but the cumulative speed is limited to 70,000 nm/s [9]. Therefore, it is highly desirable to increase the speed of such a swept source.

It is common practice to use filters inside the laser cavity to perform wavelength tuning and fast sweeping. However, they are basically mechanically tunable filters, and the mechanical sweeping speed is normally limited to tens of kilohertz, if not megahertz. For example, the Fourier-domain mode-locking technique, which is based on high-speed Fabry–Perot filters, has been proposed and demonstrated in a semiconductor optical amplifier (SOA) [10] and a fiber optical parametric amplifier (FOPA) [11]. An alternative way to perform tunability is by means of dispersion tuning [12–14]. Dispersion tuning is a relatively simple and economic approach, and the approach does not produce filter-induced cavity loss. Moreover, since the dispersion-tuning technique does not require any filter in the cavity, the speed can be potentially enhanced by this approach. Previous work using dispersion-tuning in an SOA demonstrated a speed of 200 kHz [14], and it is promising for the same technique to be applied in an FOPO configuration.

In this Letter, we demonstrate a fully fiber-integrated FOPO with a wavelength range of 109 nm and a sweep rate of 40 kHz pumped by a simple clock-modulated pump. Tuning is achieved by changing the clock frequency linearly from 1 to 1.0006 GHz. A 150 m highly nonlinear dispersion-shifted fiber (HNL-DSF) is deployed inside a cavity as the parametric gain medium. Pulses with pulse width of 150 ps are generated. This scheme has the potential to be a cost-effective source in generating swept signal for biomedical imaging outside the conventional wavelength window.

Consider a FOPO cavity that has a spool of HNL-DSF as the parametric gain medium. After a single path through the fiber, a few signal wavelength components inside the parametric gain region can be generated at the same time. Different wavelength components propagate at different group velocities because of dispersion. Thus, the round-trip time is wavelength dependent. Only the wavelength component with a round-trip time that is an integral multiple of the separation between the pump pulses will have a maximum overlap with the pump pulse and oscillate in the cavity. Suppose the optimized signal wavelength component here is λ_{S1} , and the corresponding pump clock frequency is f_1 . However, when the clock frequency that is used to modulate the pump changes from f_1 to f_2 , the corresponding succeeding pump pulse will have a separation with the signal pulse λ_{S1} at the fiber input, which is

$$\Delta T \approx \frac{n \cdot L \cdot |f_2 - f_1|}{c \cdot f_2}, \quad (1)$$

where n is the refractive index at the reference wavelength, L is the cavity length, and c is the velocity of light in free space. Since the wavelength component λ_{S1} has a time separation ΔT with the pump, it cannot oscillate inside the cavity. However, there is a wavelength component λ_{S2} that also has a separation ΔT with λ_{S1} due to the cavity dispersion, which is

$$\Delta T = |t(\lambda_{S1}) - t(\lambda_{S2})| \approx L|D(\lambda_c)| |\lambda_{S1} - \lambda_{S2}|, \quad (2)$$

where $\lambda_c = (\lambda_{S1} + \lambda_{S2})/2$, $t(\lambda)$ is the round-trip time of the signal wavelength λ , and $D(\lambda)$ is the equivalent group-velocity dispersion at wavelength λ . Thus, the λ_{S2} will be synchronized with the succeeding pump pulse, so it can start oscillating. Therefore, a different pump clock frequency will lead to a different oscillating wavelength. By this dispersion-tuning method, wavelength tuning can be achieved accordingly by adjusting the clock frequency.

The experimental setup of the FOPO is shown in Fig. 1. The cw pump with a fixed wavelength of 1555.5 nm was phase modulated by a phase modulator (PM) using a 10 Gbit/s pseudorandom binary sequence (PRBS) with pattern length $2^7 - 1$ in order to increase the threshold for stimulated Brillouin scattering. The pump was then intensity modulated by a Mach-Zehnder modulator (MZM) driven by a clock source to produce a sinusoidally modulated pump. The clock frequency can be swept from 1 to 1.0006 GHz linearly with 40 kHz speed. Afterward, the pump was amplified, filtered, and coupled into the cavity for parametric amplification through the wavelength-division-multiplexing coupler (WDMC1). The average power of the pump was measured to be 0.85 W after the erbium-doped fiber amplifier, EDFA2. Note that the cavity included a 150 m long HNL-DSF (HNDS1614CA-4-3-1, Sumitomo Electric Industries) as the gain medium, which had nonlinear coefficient of $30 \text{ W}^{-1} \text{ km}^{-1}$, a zero-dispersion wavelength of 1554 nm, and a dispersion slope of $0.02 \text{ ps/nm}^2/\text{km}$. The FOPO output spectrum was monitored by an optical spectrum analyzer (OSA) through a 1/99 coupler. WDMC2 and WDMC3 were combined to ensure that only the signal (longer wavelength sideband) can oscillate inside the cavity by blocking the undesired pump and idler. A 90/10 coupler in the cavity provided 90% feedback and 10% output. Tuning was achieved by adjusting the clock frequency, with no further adjustment of other components. The 200 m dispersion-compensating fiber (DK-425, Lucent Technologies) in the cavity is used to provide enough dispersion in the cavity to perform dispersion tuning, as used in [13,14]. It had a dispersion of -96.6 ps/nm/km at 1600 nm. The optical delay line (ODL) in the

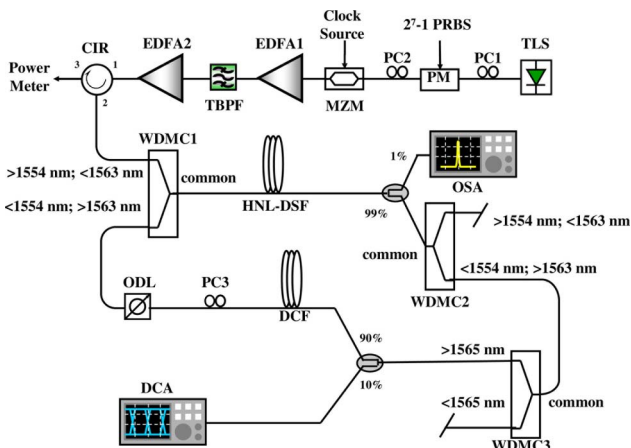

Fig. 1. (Color online) Experimental setup of the FOPO. PC, polarization controller; EDFA, erbium-doped fiber amplifier; TBPF, tunable bandpass filter; OSA, optical spectrum analyzer; MZM, Mach-Zehnder modulator; ODL, optical delay line; CIR, circulator.

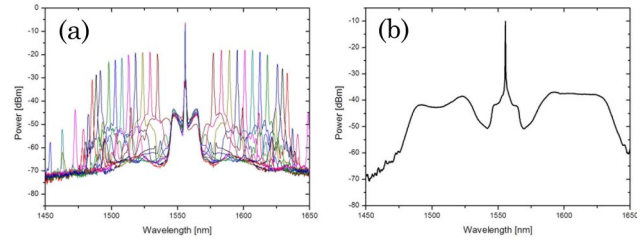

Fig. 2. (Color online) (a) Static optical spectra measured at HNL-DSF output using OSA; (b) dynamic optical spectrum measured at HNL-DSF output using OSA.

cavity was used to adjust the cavity length so the signal could be synchronized with the pump. Once optimized, it is not necessary to adjust the ODL during wavelength tuning. The remaining fiber in the cavity was standard single-mode fiber (SMF), which was used to connect the components in the cavity and which had a dispersion of 17 ps/nm/km and a dispersion slope of $0.06 \text{ ps/nm}^2/\text{km}$ at 1550 nm. The total length of this discrete SMF was 20 m. The output waveform of the signal was recorded by using a digital communication analyzer (DCA).

Figure 2(a) shows the static optical spectra measured at the HNL-DSF output when the pump is modulated with discrete clock frequency. The pump power remained the same for each tuning. Wavelength tuning is achieved by changing the clock frequency from 1 to 1.0006 GHz, with no further adjustment of other components. The achievable tuning range is from 1484 to 1535 nm and from 1577 to 1635 nm, which is as wide as 109 nm, with a wavelength span of 151 nm. The smaller peaks are high-order parametric components. Further tuning is limited by the gain region of the FOPA when the pump wavelength is fixed at 1555.5 nm. The tuning range can be potentially improved by pursuing a different kind of fiber, which may have a wider FOPA gain bandwidth than the HNL-DSF we used in this Letter.

In Fig. 2(b), we show the dynamic optical spectrum when using swept clock frequency scanning linearly from 1 to 1.0006 GHz, with a sweeping speed of 40 kHz. A flat wide spectrum is achieved. The output has less than 10 dB power ripples from 1484 to 1534.6 nm, and from 1577.6 to 1634.8 nm, which is as wide as 107.8 nm, and matches very well with the 109 nm tuning range obtained from Fig. 2(a). The intensity of the spectrum is lower than the spectra shown in Fig. 2(a), which is due to the integral time of the peak-hold function of the OSA when the sweep rate is fast, as discussed in [14]. The total sweep rate is more than $4,000,000 \text{ nm/s}$, which is 50 times larger than that reported in [9].

Figure 3 shows the experimentally measured sideband (oscillating) wavelengths (circles) as a function of clock frequency. The superimposed solid curve is the theoretical prediction using Eqs. (1) and (2). The agreement between the experimental and theoretical wavelengths is excellent. The measured tuning sensitivity is 97 nm/MHz , which matches well with the calculated value of 96 nm/MHz . Therefore, linear operation of the swept source is achieved.

Figure 4 shows the signal waveform at 1601 nm measured by the DCA. The repetition rate of the signal is measured to be 1.00024 GHz, the same as the frequency of the sinusoidal clock that was used to modulate the pump.

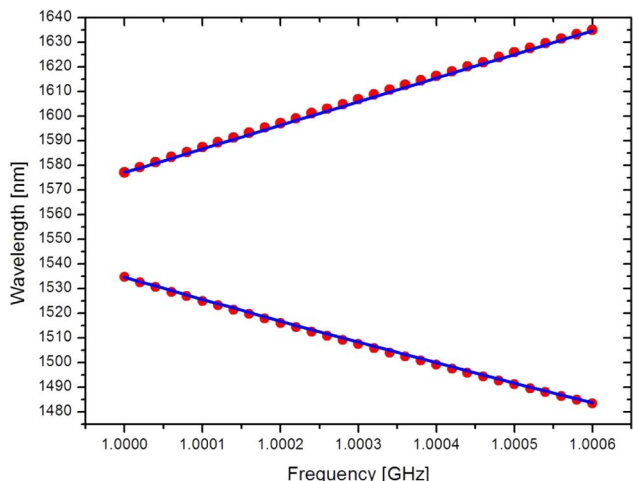

Fig. 3. (Color online) Experimental measured sideband wavelengths as a function of clock frequency (circles). Theoretical oscillating wavelengths predicted by Eqs. (1) and (2) (solid curves).

The pulse width measured from the DCA is 150 ps, which is narrower than the sinusoidal pump, due to the pulse compression effect of the FOPO [6]. The noise at the mark level is inherited from the noise of the EDFAs. The timing jitter (rms) of the signal is measured to be 5.76 ps, which is primarily due to the phase dithering of the pump. The output power of the FOPO is 9.6 dBm, corresponding to an external conversion efficiency of 1.1%. The relatively low external efficiency is primarily due to the low output coupling ratio, which is 10% in the current configuration. A limitation to the sweep speed of the FOPO is the cavity length. To keep the FOPO operating, the walk-off between consecutive, overlapping signal pulses must not be larger than half the pulse duration. Thus, after one round trip, the total wavelength shift of the signal pulses must be lower than a certain value. The shorter the cavity length, the smaller the round-trip time of the signal, which leads to a smaller total wavelength shift and allows a higher sweep speed. By pursuing a

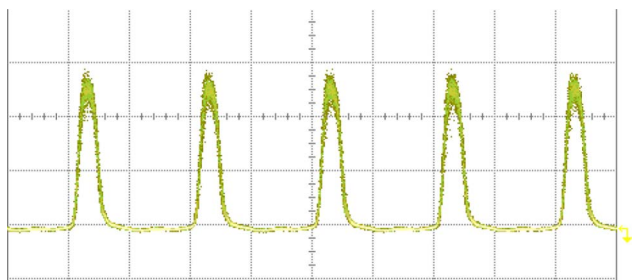

Fig. 4. (Color online) Waveform of the output pulses at 1601 nm.

faster clock source and a shorter cavity length, the sweep speed can be further increased.

In conclusion, a fast and wide tuning range wavelength-swept FOPO was demonstrated. With dispersion tuning in the cavity, a wide wavelength range of 109 nm and a fast sweep rate of 40 kHz were obtained. The cumulative speed exceeds 4,000,000 nm/s. Pulses are generated with a pulse width of 150 ps at a repetition rate of 1 GHz. By pursuing different kinds of fiber, the tuning range is expected to be improved. Moreover, the swept speed can be further increased by adopting a higher speed swept clock generator and a shorter cavity length. This scheme has the potential to be a cost-effective source in generation of swept signals for biomedical imaging and sensing applications in the non-conventional wavelength bands.

The work described in this Letter is partially supported by grants from the Research Grants Council of the Hong Kong Special Administrative Region, China (projects HKU 7179/08E and HKU 7183/09E). The authors also acknowledge Sumitomo Electric Industries for providing the HNL-DSF.

References

1. S. R. Chinn, E. A. Swanson, and J. G. Fujimoto, *Opt. Lett.* **22**, 340 (1997).
2. Y. Wang, Y. Cui, and B. Yun, *IEEE Photonics Technol. Lett.* **18**, 1539 (2006).
3. P. F. Wysocki, M. J. F. Digonnet, and B. Y. Kim, *Opt. Lett.* **15**, 879 (1990).
4. M. E. Klein, A. Robertson, M. A. Tremont, R. Wallenstein, and K.-J. Boller, *Appl. Phys. B* **73**, 1 (2001).
5. M. E. Marhic, *Fiber Optical Parametric Amplifiers, Oscillators And Related Devices* (Cambridge U. Press, 2007).
6. J. E. Sharping, *J. Lightwave Technol.* **26**, 2184 (2008).
7. G. K. L. Wong, S. G. Murdoch, R. Leonhardt, J. D. Harvey, and V. Marie, *Opt. Express* **15**, 2947 (2007).
8. Y. Zhou, K. K. Y. Cheung, S. Yang, P. C. Chui, and K. K. Y. Wong, *Opt. Lett.* **34**, 989 (2009).
9. B. P. P. Kuo, N. Alic, P. F. Wysocki, and S. Radic, "Simultaneous NIR and SWIR wavelength-swept generation over record 329 nm range using swept-pump fiber optical parametric oscillator," presented at the *Optical Fiber Communication Conference*, San Diego, Calif., USA, 21–25 March 2010, postdeadline paper PA9.
10. R. Huber, D. C. Adler, and J. G. Fujimoto, *Opt. Lett.* **31**, 2975 (2006).
11. K. H. Y. Cheng, B. A. Standish, V. X. D. Yang, K. K. Y. Cheung, X. Gu, E. Y. Lam, and K. K. Y. Wong, *Opt. Express* **18**, 1909 (2010).
12. R. H. Stolen, C. Lin, and R. K. Jain, *Appl. Phys. Lett.* **30**, 340 (1977).
13. S. Yang, K. K. Y. Cheung, Y. Zhou, and K. K. Y. Wong, *IEEE Photonics Technol. Lett.* **22**, 580 (2010).
14. Y. Nakazaki and S. Yamashita, *Opt. Express* **17**, 8310 (2009).