



<b>Title</b>	<b>Diffusion-weighted balanced SSFP (DW-bSSFP): a new approach to diffusion tensor imaging</b>
<b>Author(s)</b>	<b>Cheung, MMH; Cheung, JSC; Xiao, L; Chow, AMK; Chan, KWY; Wu, EX</b>
<b>Citation</b>	<b>The ISMRM-ESMRMB Joint Annual Meeting 2010, Stockholm, Sweden, 1-7 May 2010.</b>
<b>Issued Date</b>	<b>2010</b>
<b>URL</b>	<b><a href="http://hdl.handle.net/10722/129729">http://hdl.handle.net/10722/129729</a></b>
<b>Rights</b>	<b>Creative Commons: Attribution 3.0 Hong Kong License</b>

# Diffusion-weighted Balanced SSFP (DW-bSSFP): A New Approach to Diffusion Tensor Imaging

M. M. Cheung<sup>1,2</sup>, J. S. Cheung<sup>1,2</sup>, L. Xiao<sup>1,2</sup>, A. M. Chow<sup>1,2</sup>, K. W. Chan<sup>1,2</sup>, and E. X. Wu<sup>1,2</sup>

<sup>1</sup>Laboratory of Biomedical Imaging and Signal Processing, The University of Hong Kong, Pokfulam, Hong Kong, China, People's Republic of, <sup>2</sup>Department of Electrical and Electronic Engineering, The University of Hong Kong, Pokfulam, Hong Kong, China, People's Republic of

**Introduction** DW-EPI offers high acquisition speed, however it generally suffers from low spatial resolution and geometric distortion. SSFP is a possible alternative to perform diffusion imaging with higher resolution and with no distortion artifacts that is inherent in EPI. Analytical analysis of DW-SSFP can be complicated because relaxation terms cannot be decoupled from the effect of diffusion. The effect of diffusion on gradient echo sequences has been studied extensively (1-9), and several studies were performed to explore the feasibility of obtaining and interpreting DWI and DTI using DW-SSFP (1-3,6). In these studies, pulsed unipolar diffusion gradients were used in the SSFP sequence. Though unipolar gradient of short duration can provide high diffusion sensitivity, it is sensitive to the flip angle and bulk motion as compared with bipolar gradient (4). Yet no attempts have been reported so far introducing diffusion gradients into bSSFP sequence, except one study incorporating diffusion weighting in preparatory module prior to the sequence (10). With the advance of hardware system, bSSFP has been gaining importance recently due to its high SNR-efficiency and unique T2/T1-weighted contrast (11). In this work, we formulate the diffusion effect in bSSFP sequence with a pair of bipolar diffusion gradients.

**Theory** A pair of bipolar gradients with amplitude  $G_d$  and duration  $2\delta$  was added into the TrueFISP sequence as shown in Fig. 1. The analytical expression was derived from the Bloch Torrey's equation (12) in a way similar to the procedures in (5) and (6). Assuming the phase is totally refocused and the off-resonance effect is negligible, we derived that the exact transverse magnetization  $M$  in steady state with alternating RF pulse with the presence of diffusion sensitizing gradients is:

$$M(\theta, \frac{TR}{2}) = \frac{e^{-bD} M_0 \sin \alpha (1 - E_1)}{(1 + e^{-2bD} E_2 \cos \alpha - E_1 \cos \alpha - e^{-2bD} E_1 E_2)}, \quad [1]$$

where  $\alpha$  is the magnitude of the flip angle,  $M_0$  is the initial magnetization,  $b$  is the conventionally defined diffusion weighting factor ( $b = \frac{2}{3}(\gamma G_d)^2 \delta^3$ ) (13),  $E_1 = e^{-TR/T1}$ ,  $E_2 = e^{-TR/T2}$ . When there is no diffusion ( $D=0$ ), Eq.(1) reduces to the expression of transverse magnetization in bSSFP (14). Assuming the T1 effect is negligible when  $TR \ll T1$  (i.e.,  $E_1=1$ ), we can express the diffusion attenuation as:

$$\frac{S}{S_0} = \frac{e^{-bD} (1 - E_2)}{(1 - E_2 e^{-2bD})}, \quad [2]$$

where  $S_0$  is the signal intensity obtained with  $G_d=0$ . When  $E_2 e^{-bD} \ll 1$ , the signal attenuation can be approximated by

$$S/S_0 = e^{-bD} \quad [3]$$

## Experimental Demonstration

All the MR acquisitions were performed with a Bruker PharmaScan 7T scanner with maximum gradient of 360mT/m. **Gd phantom** Gadolinium phantom (1mM) was scanned. The proposed DW-bSSFP sequence was applied with the following parameters: TR/TE=46/13ms,  $\delta=10$ ms, FOV=45x45mm<sup>2</sup>, acquisition matrix=128x128, slice thickness=1mm, NEX=16. In order to verify the independency of flip angle to the signal decay, diffusion sensitizing gradients ( $\delta=8$ ms,  $G=108$  mT/m,  $b=285$  s/mm<sup>2</sup>) along the readout direction using different flip angles (15°, 30°, 45°, 60°, 75°) were used. The acquisition was repeated 8 times with each flip angle. The dependency of signal attenuation with flip angles is plotted in Fig. 2. There was no statistical significance (ANOVA) among signal attenuations of different flip angles. However, the standard deviations were large in certain flip angles, as the optimized flip angle was around 50° computed from the measured T1 (55ms) and T2 (226ms) of the phantom.

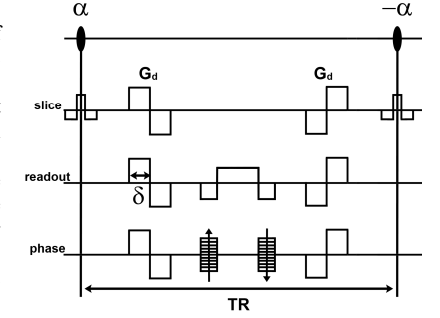

Fig. 1. Proposed DW bSSFP sequence with two bipolar gradients ( $G_d$ ) inserted with  $TE=TR/2$ . All the imaging and diffusion gradients are balanced.

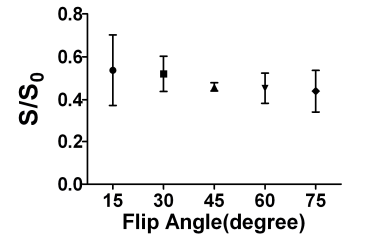

Fig. 2. Signal attenuation vs the flip angle (Mean±SD). The 1mM Gd phantom was scanned with diffusion gradient ( $\delta=8$ ms,  $G=108$  mT/m,  $b=285$  s/mm<sup>2</sup>) along readout direction for 8 repetitions.

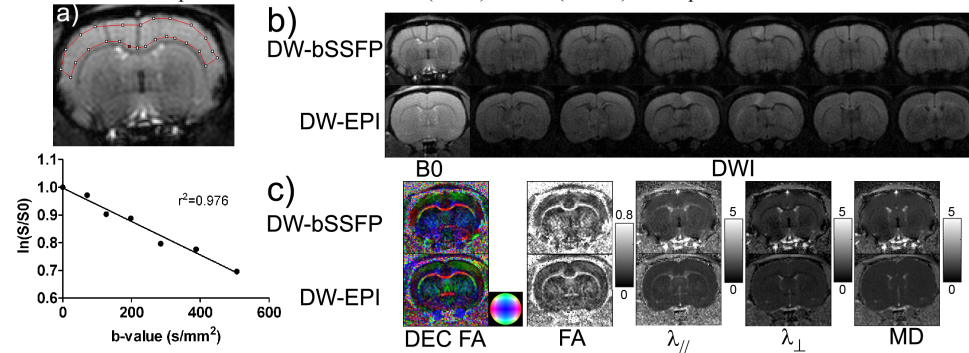

Fig. 3. a) By drawing an ROI on the cortex and plotting the signal intensity against b-value, the signal decay is nearly monoexponential to the b-value. b) DWIs along 6 different directions and B0 images using DW-bSSFP and DW-EPI. Note that the diffusion attenuation of anisotropic white matter varies with the direction of applied diffusion gradient. c) DTI parametric maps (directionally encoded colour FA,  $\lambda_{//}$ ,  $\lambda_{\perp}$ , MD). Unit of diffusivities are mm<sup>2</sup>/ms.

attenuation among different diffusion gradient directions. Therefore, DW-bSSFP is able to provide microstructural information regarding tissue anisotropy. DTI was also computed and the parametric maps are shown in Fig. 3c. Note that the relatively long TE in our sequence caused signal loss in some regions with high susceptibility as shown in Fig. 3. Nonetheless, the image quality can be improved with a stronger gradient system, in which TR can be reduced. Thus, the proposed sequence may be useful in clinical systems, as the susceptibility effect scales with field strength.

**Conclusion** In this work, we have presented the analysis of DW-bSSFP with the incorporation of bipolar gradients in a symmetrical way. With suitable choice of TR and b-value, the effect of relaxation terms could be minimized. DW-bSSFP may allow us to perform DTI in high resolution without geometric distortion.

**Reference** 1.McNab JA et al. Neuroimage 2009 2.McNab JA et al. MRM 2008 3.Deoni SC et al. MRM 2004 4.Ding S et al. MRM 1995 5.Kaiser R et al. J Chem Phys 1974. 6.Wu EX et al. J Magn Reson 1990 7.Zur Y et al. MRM 1997 8.Buxton RB et al. MRM 1993 9.Carney CE et al. MRM 1991 10.Absil J et al. ISMRM 2007 11.Scheffler K et al. Eur Radiol 2003 12.Torrey HC et al. Phys Rev 1956 13.Stejskal EO et al. J Chem Phys 1965 14.Haacke EM et al. John Wiley & Sons 1999 15.Hasan KM et al. JMRI 2001

**In vivo rat brain** A normal adult SD rat (280g) was scanned using the proposed DW-bSSFP sequence with the following parameters: TR/TE=38/19ms,  $\delta=8$ ms,  $b=989$ s/mm<sup>2</sup>, FA=30°, FOV=32x32mm<sup>2</sup>, acquisition matrix=128x128, NEX=16. Fieldmap-based shimming technique was applied prior to diffusion experiment. Diffusion encoded gradients were applied along 6 directions in an icosahedral scheme (15). 8-shot SE-EPI (TR/TE=3200/28ms,  $\delta/\Delta=5/10$ ms,  $b=1000$ s/mm<sup>2</sup>) was also applied with the same slice localization and resolution for comparison. Signal attenuation was fitted into Eq. (3). DTI parametric maps were computed by DTIStudio (JHU). The high correlation coefficient ( $r=0.987$ ) between the logarithm of signal attenuation of DW-SSFP and b-value demonstrated that the assumptions to reach Eq.(3) are valid *in vivo*. DWI and B0 images are shown in Fig. 3b. The well aligned white matter shows a dependency of signal