



Title	A tight bound for combinatorial edge guards in orthogonal polygons
Other Contributor(s)	University of Hong Kong. Dept. of Computer Science.
Author(s)	Yiu, S. M.
Citation	
Issued Date	1993
URL	http://hdl.handle.net/10722/54862
Rights	Creative Commons: Attribution 3.0 Hong Kong License

COMPUTER SCIENCE PUBLICATION

**A TIGHT BOUND FOR COMBINATORIAL EDGE GUARDS
IN ORTHOGONAL POLYGONS**

S.M. Yiu

Technical Report TR-93-07

Nov. 1993



**DEPARTMENT OF COMPUTER SCIENCE
FACULTY OF ENGINEERING
UNIVERSITY OF HONG KONG
POKFULAM ROAD
HONG KONG**

UNIVERSITY OF HONG KONG
LIBRARY

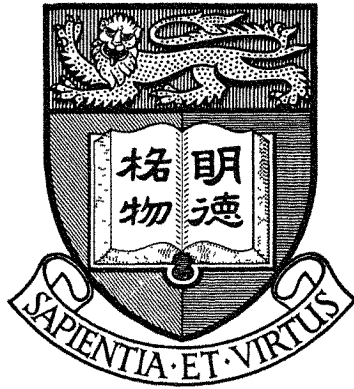

*This book was a gift
from*

Dept. of Computer Science
The University of Hong Kong

A Tight Bound for Combinatorial Edge Guards in Orthogonal Polygons

S.M. Yiu

Department of Computer Science
University of Hong Kong
Hong Kong
(email: syiu@cse.hku.hk)

Abstract

This note gives an example to show that $\lfloor n/5 \rfloor$ combinatorial diagonal guards are sometimes necessary for orthogonal polygons. This closes the gap between the lower bound and upper bound. The example also gives the same lower bound for the combinatorial edge guards in orthogonal polygons and the bound can be shown to be tight.

1 Introduction

An *orthogonal (rectilinear)* polygon is one whose edges alternate between horizontal and vertical. A *diagonal guard* as defined by O'Rourke[1] is one which can patrol the segment between two vertices provided that the segment lies entirely in the polygon. A polygon is said to be covered by a set of diagonal guards if every point of the polygon is *weakly visible* from at least one guard of the set. A point is said to be weakly visible from a segment if there exists a point in the segment such that the line joining those two points is entirely inside the polygon. Given any convex quadrilateralization of a polygon, define a quadrilateralization graph (we will call it a quad graph below) as follows: the nodes of the graph are the vertices of the polygon and the arcs are the edges of the polygon plus the added diagonals of the quadrilateralization. A *combinatorial diagonal guard* is a pair of nodes in the graph which across any arc and a *combinatorial edge guard* is a pair of nodes which corresponds to an edge of the original polygon. A quadrilateralization graph is said to be dominated by a set of combinatorial guards if every quadrilateral face shares at least a node with some of the guards.

In [1, section 3.4], O'Rourke posed the following question: Are $\lfloor (3n+4)/16 \rfloor$ combinatorial diagonal guards always sufficient to dominate any quad graph of an

orthogonal polygon where n is the number of vertices of the polygon? The question was answered by Shermer [2] negatively. He gave an example to show that there exists quad graphs which require $\lfloor (5n+6)/26 \rfloor$ combinatorial diagonal guards. However, whether the bound is tight was still an open question. In this note, we gave another example to show that sometimes $\lfloor n/5 \rfloor$ combinatorial diagonal guards are necessary which matches the upper bound given by Aggarwal (cited in [1]). And the same example will establish the same lower bound for the combinatorial edge guard for orthogonal polygons and it will be shown that the bound is tight.

2 Lower Bound for Combinatorial Diagonal/Edge Guards for Orthogonal Polygons

The following example shows that there exists quad graph of orthogonal polygons which require $\lfloor n/5 \rfloor$ combinatorial guards. Figure 1a shows an 10-nodes quad graph which requires two guards. Figure 1b shows each additional of 10 nodes require 2 more guards. Each numbered quadrilateral face requires its own guard because these quadrilateral faces are not connected to each other by any single edge or diagonal. Figure 1(c) shows how to generalize it to n nodes.

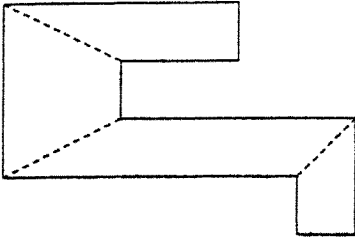

Figure (1a)

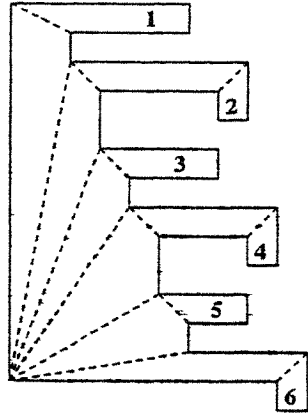

Figure (1b)

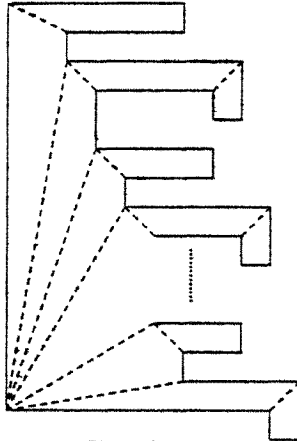

Figure (1c)

Lower Bound: Combinatorial Mobile/Diagonal/Edge Guards for Orthogonal Polygon.

Figure (1a): 10 vertices require 2 guards.

Figure (1b): Each additional of 10 vertices require two more guards.

Figure (1c): Generalize to show that n vertices require $\lfloor n/5 \rfloor$ guards.

3 Sufficiency for Combinatorial Edge Guards in Orthogonal Polygon

In this section, we will show that $\lfloor n/5 \rfloor$ combinatorial edge guards are always sufficient to dominate any quad graphs of any convex quadrilateralizable polygons.

Lemma 1: Let q be the number of any quadrilaterals of a convex quadrilateralizable polygon of n vertices, $n = 2q + 2$.

Proof: It follows directly from the equality, $(n-2)\pi = 2\pi q$. Hence, the term $\lfloor n/5 \rfloor$ will be replaced by $\lfloor (2q+2)/5 \rfloor$ throughout the proof.

Lemma 2: Let Q be a quadrilateralization of a convex quadrilateralizable polygon P . There always exists a diagonal D in Q that partitions P into two pieces, one of which contains 2, 3 or 4 quadrilaterals.

Proof (O'Rourke [1]): Let D be a diagonal that cuts off a minimum number of quadrilaterals that is at least 2. Let $k \geq 2$ be this minimum number. Assume F is the quadrilateral face supported by D . The region cut through by the other sides of F cannot contain more than one quadrilateral according to the minimality of k (figure 2), so $k \leq 4$.

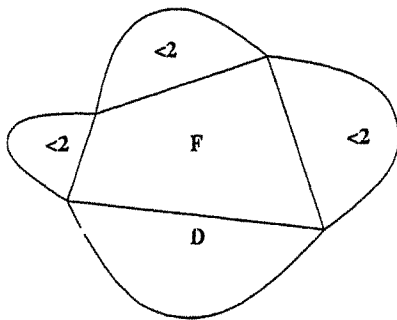

Diagonal D cuts off a minimum number of quadrilaterals > 1

Lemma 3: The piece cut out in lemma 2 can always be dominated by one edge guard if it contains exactly 2 or 3 quadrilaterals. And it can be dominated by two edge

guards if it contains 4 quadrilaterals. In case of 2 or 4 quadrilaterals, one end of the diagonal D can always share a node with one of the guards.

Proof: In figure 3, it shows the possible configurations of the cut off part and it is easy to see that the above lemma holds for all cases where g shows the possible location of the guard(s) in each case.

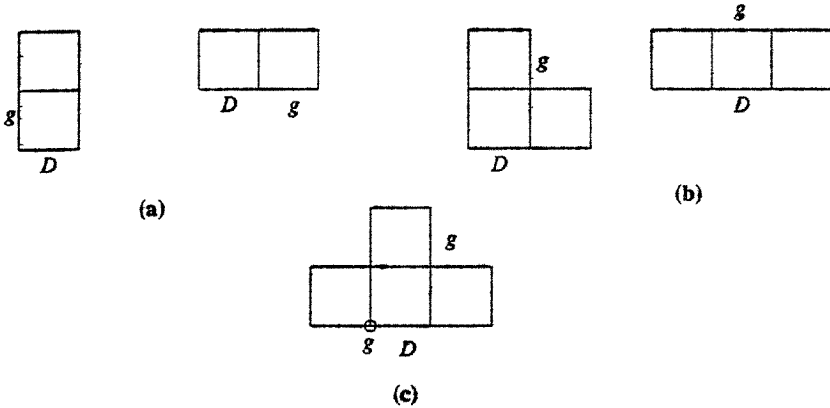

Figure 3: possible configurations of the cut off part when $k = 2$ (a), 3 (b) and 4 (c)

Before proceeding to the next lemma, let us take a look on the behaviour of the values of the number $\lfloor (2q+2)/5 \rfloor$. From the following table, we can see the number of guards increases only at some critical values of q . We will use induction to prove our main result, $\lfloor (2q+2)/5 \rfloor$ guards are sufficient. According to lemma 3, we will cut off either 2, 3 or 4 quadrilaterals from the given graph and apply the induction hypothesis to the remaining part. It works nicely for most values of q . For example, if $q = 7$ and we cut off 2 quadrilaterals from it. The remaining part will have 5 quadrilaterals and requires only 2 guards together with one guard for the cut off part which gives the sufficiency of three guards. However, if $q = 6$, the induction step is not that straight forward and requires the sharing of guards between the cut off part and the remaining portion. So, in the induction step, two more lemmas, lemmas 4 and 5, will be used to ensure the sharing between the two portions is possible. And the assumption used in both lemmas is in fact the induction hypothesis of the main theorem we are going to show.

q	$\lfloor (2q+2)/5 \rfloor$
2	1
3	1
4	2
5	2
6	2
7	3
8	3
9	4
10	4
11	4
12	5
⋮	⋮
⋮	⋮
⋮	⋮
$5k$	$2k$
$5k+1$	$2k$
$5k+2$	$2k+1$
$5k+3$	$2k+1$
$5k+4$	$2k+2$

Table 1: behaviour of $\lfloor (2q+2)/5 \rfloor$

Lemma 4: Suppose $\lfloor (2q+2)/5 \rfloor$ combinatorial edge guards are always sufficient to dominate any quad graph of a convex quadrilateralizable polygon and an edge E is called *essential* if without placing a guard on this edge, more than $\lfloor (2q+2)/5 \rfloor$ are required. Then for $q = 5k+3$, all edges are not essential.

Proof: The proof is by induction on k . If $k = 0$, there are only two configurations for the quad graph. It is easy to check that all the edges are not essential which establishes the induction basis. Now, for the induction step, if either end of E is of degree 2, then the edge is obviously not essential. Assume both ends of E are of degree > 2 . Now, let Q be the quadrilateral face supported by e and the degree of Q is defined as the number of disconnected subgraphs resulting from the removal of Q .

Case 1: Q is of degree 2.

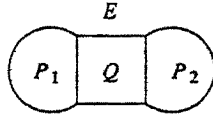

Figure 4: Q is of degree 2

Subcase 1a: P_1 has $5k_1$ quadrilaterals and P_2 has $(5k_2+2)$ quadrilaterals.

Partition the graph into two subgraphs, G_1 and G_2 , as shown in figure 5. Note that the numbers in the regions denote the number of quadrilaterals in that region mod 5. G_1 will have $(5k_1+1)$ quadrilaterals and G_2 will have $(5k_2+3)$ quadrilaterals. By the assumption, G_1 requires $2k_1$ edge guards while G_2 needs $2k_2+1$ guards. In both subgraphs, if a guard is put at the edge E , it can be easily replaced by one other than E since there exists a node of E which is degree 2 in either case. Hence, without putting a guard at E , the graph can still be dominated by $\lfloor (2q+2)/5 \rfloor$ guards.

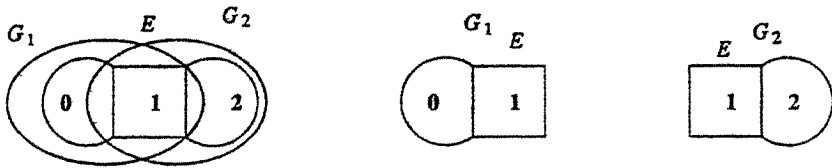

Figure 5: subcase 1a

Subcase 1b: P_1 has $(5k_1+1)$ quadrilaterals and P_2 has $(5k_2+1)$ quadrilaterals.

Partition the graph as shown into two subgraphs, G_1 and G_2 . G_1 requires $2k_1$ guards while G_2 requires $2k_2$ guards. If either (a,b) or (c,d) (say, (a,b)) is included in one of G_1 or G_2 , then it can be replaced by two edge guards, namely (a,e) and (b,f) . If both (a,b) and (c,d) are included, replace them by the edge guard (b,d) and two other edge guards, (a,e) and (c,g) . If none of them is included, dominate the middle quadrilateral by adding the edge guard (b,d) . In all cases, $2k+1$ guards suffice.

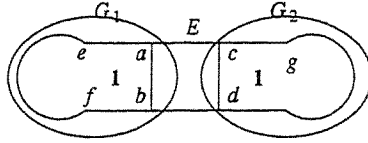

Figure 6: subcase 1b

Subcase 1c: P_1 has $(5k_1+3)$ quadrilaterals and P_2 has $(5k_2+4)$ quadrilaterals.

Partition the graph as shown into G_1 and G_2 . By the hypothesis, G_1 has $(5k_1+3)$ quadrilaterals and can be dominated by $2k_1+1$ edge guards without putting any guard at (a,b) . G_2 has $(5k_2+5)$ quadrilaterals, so can be dominated by $2k_2+2$ guards, so in total, $(2k_1+2k_2+3)$ edge guards are sufficient to dominate the original graph. i.e. $(2k+1)$ guards suffice.

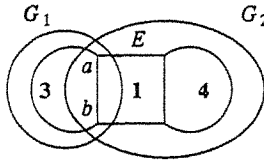

Figure 7: subcase 1c

Case 2: Q is of degree 3.

P_1 , P_2 and P_3 are the quad graphs obtained by cutting off Q . Let q_1 , q_2 and q_3 be the number of quadrilaterals in P_1 , P_2 and P_3 respectively.

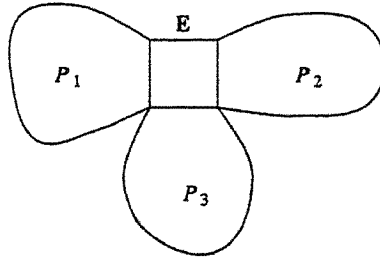

Figure 8: Q is of degree 3

Subcase 2a: $q_1 = (5k_1)$ and $q_2 + q_3 = (5k_2+2)$.

Partition the original graph into two subgraphs, G_1 and G_2 , as shown. By the assumption, G_1 requires $2k_1$ guards and G_2 requires $(2k_2+1)$ guards and none of the guards will be placed at E (if one is placed at E , it can be easily fixed as described in the above), so $(2k+1)$ guards suffice to dominate the original graph.

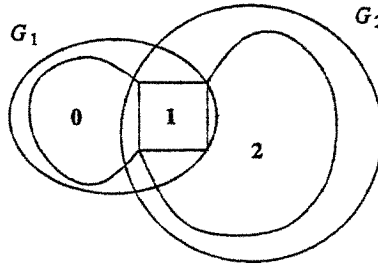

Figure 9: subcase 2a

Subcase 2b: $q_1 = (5k_1+1)$ and $q_2 + q_3 = (5k_2+1)$.

There are five possible configurations. In case (a), G_1 has $(5p_1+3)$ quadrilaterals and G_2 has $(5p_2+1)$ quadrilaterals. By the hypothesis and assumption, G_1 requires $(2p_1+1)$ guards without putting any at E while G_2 requires $2p_2$ guards. Since there must be a guard placed at vertex a or b in G_2 , so if a guard is placed at (a,b) in G_1 , then it can be replaced by another one easily. Case (b) is the same as subcase 2a. Case

(c) is the same as subcase 2c. Case (d) is the same as subcase 2e and case (e) is the same as subcase 2d.

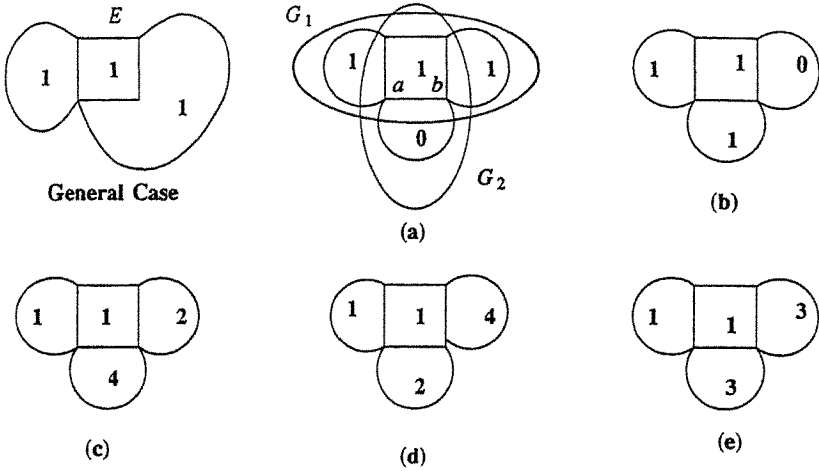

Figure 10: subcase 2b

Subcase 2c: $q_1 = (5k_1+2)$ and $q_2 + q_3 = (5k_2)$.

Partition the original graph into two subgraphs, G_1 and G_2 , as shown. By the assumption, G_1 requires $(2k_1+1)$ guards and G_2 requires $2k_2$ guards and none of the guards will be placed at E , so $(2k+1)$ guards suffice to dominate the original graph.

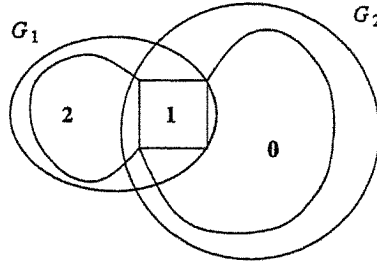

Figure 11: subcase 2c

Subcase 2d: $q_1 = (5k_1+3)$ and $q_2 + q_3 = (5k_2+4)$.

Partition it into G_1 and G_2 . G_1 requires at most $(2k_1+1)$ guards without putting any at (a,b) and G_2 requires at most $(2k_2+2)$ guards, so at most $(2k+1)$ guards are required.

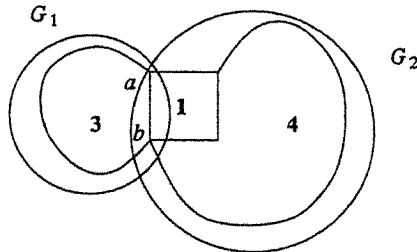

Figure 12: subcase 2d

Subcase 2e: $q_1 = (5k_1+4)$ and $q_2 + q_3 = (5k_2+3)$.

Cut off P_1 and Q . Augment the graph as shown by adding one extra quadrilaterals $abcd$ to it (figure a). The augmented graph will have $(5k_1+6)$ quadrilaterals, so requires $(2k_1+2)$ guards. To dominate the quadrilateral $abcd$, the guard at d must exist, otherwise the guard which dominates the quadrilateral $abcd$ can be replaced by one at d since it will only dominate the added quadrilaterals. Assume the guard at d exists, augment the remaining graph by adding two quadrilaterals as shown (figure b).

Again if a guard is placed at (e,f) , it can be deleted when the two augmented pieces are recombined to form the original graph since Q is already covered by the guard at d . Otherwise, (g,h) must exist and it can be deleted in the original graph since h and d coincide in the original graph. In all cases, at most $(2k+1)$ guards suffice.

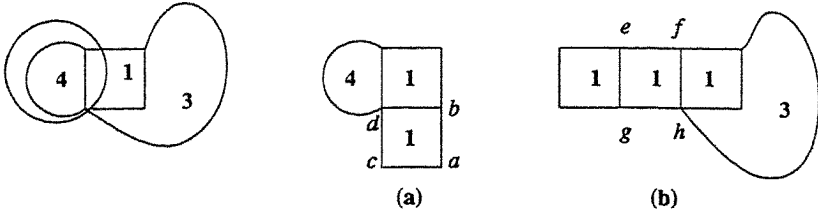

Figure 13: subcase 2e

Lemma 5: Suppose $\lfloor (2q+2)/5 \rfloor$ combinatorial edge guards are always sufficient to dominate any quad graph of a convex quadrilateralizable polygon, let E be any edge of a quad graph, if a vertex guard is available that we may choose to place at either end of E , then for $q = 5k+4$, an addition of $(2k+1)$ edge guards are sufficient to dominate any quad graph.

Proof: The proof is by induction on k . If $k = 0$, there are only four possible configurations and it is not hard to check that for each edge, if a vertex guard can be placed at either end of it, an addition of 1 edge guard is sufficient to dominate the graph. This establishes the induction basis. Now, let Q be the quadrilateral supported by E . There are two cases depending on the degree of Q .

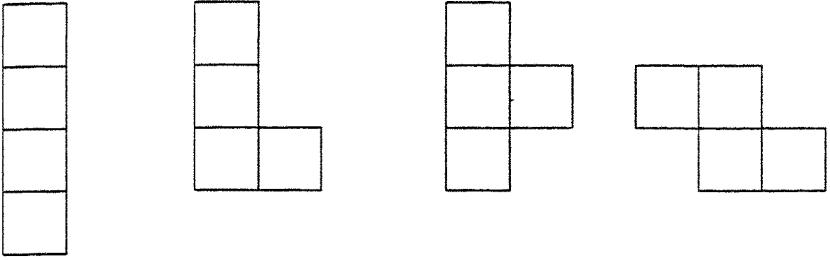

Figure 14: possible configurations of 4 quadrilaterals

Case 1: Degree of Q is 1.

In this case, cut off Q at the only diagonal f and leave the graph with $(5k+3)$ quadrilaterals and apply lemma 4, the graph can be dominated by $(2k+1)$ edge guards without putting any guards at f .

Case 2: Degree of $Q > 1$.

Without loss of generality, assume Q is of degree 3. P_1 , P_2 and P_3 are the quad graphs obtained by cutting off Q . Let q_1 , q_2 and q_3 be the number of quadrilaterals in P_1 , P_2 and P_3 respectively. And assume $q_1 > 0$.

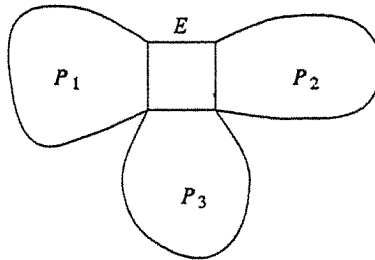

Figure 15: Q is of degree 3

Subcase 2a: $q_1 = 5k_1$ and $q_2+q_3 = (5k_2+3)$.

Partition the graph as shown into two subgraphs, G_1 and G_2 . Apply the induction and hypothesis, G_1 requires at most $2k_1$ guards and G_2 requires at most $(2k_2+1)$ guards.

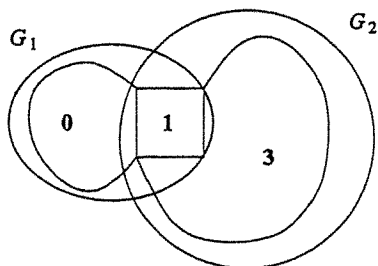

Figure 16: subcase 2a

Subcase 2b: $q_1 = (5k_1+1)$ and $q_2 + q_3 = (5k_2+2)$.

Partition the graph as shown. G_1 requires at most $2k_1$ guards while G_2 requires at most $(2k_2+1)$ guards. If in G_1 , a guard is placed at (a,b) , then the vertex guard can be put at a and replace the guard (a,b) by another one at b .

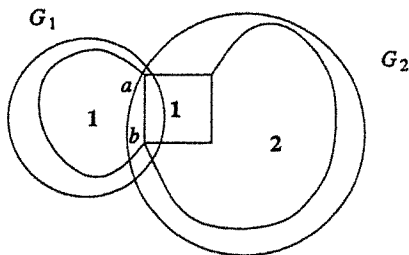

Figure 17: subcase 2b

Subcase 2c: $q_1 = (5k_1+2)$ and $q_2 + q_3 = (5k_2+1)$.

There are five possible cases. Case (a) is the same as subcase 2b. Case (b) is the same as subcase 2a. In case (c), partition the graph into three subgraphs, G_1 , G_2 and G_3 . In G_1 , apply lemma 4, at most $(2k_1+1)$ guards are required without putting any at (a,d) . To dominate Q , either the guard (a,b) exists, in this case, it can be deleted and replaced by the vertex guard at a since it only dominates the quadrilateral Q . Or the guard at c must exist. Similarly for G_3 . If one guard is deleted from either G_1 or G_3 , append Q to G_2 . Otherwise, there must be guards at c and e , we can apply the

hypothesis to G_2 , in all cases, at most $(2k+1)$ guards are needed. Case (d) is the same as case (e) of subcase 2e and case (e) is the same as subcase 2d. Lastly, there is a special case when $q_2 = 0$ (case (f)). Partition it into two subgraphs, G_1 and G_2 . G_1 requires at most $(2k_1+1)$ guards without putting any at (a,b) . Similar to the above argument, either one guard can be deleted or a guard must exist at c . Then, G_2 will require at most $2k_2$ guards without putting one at (c,d) .

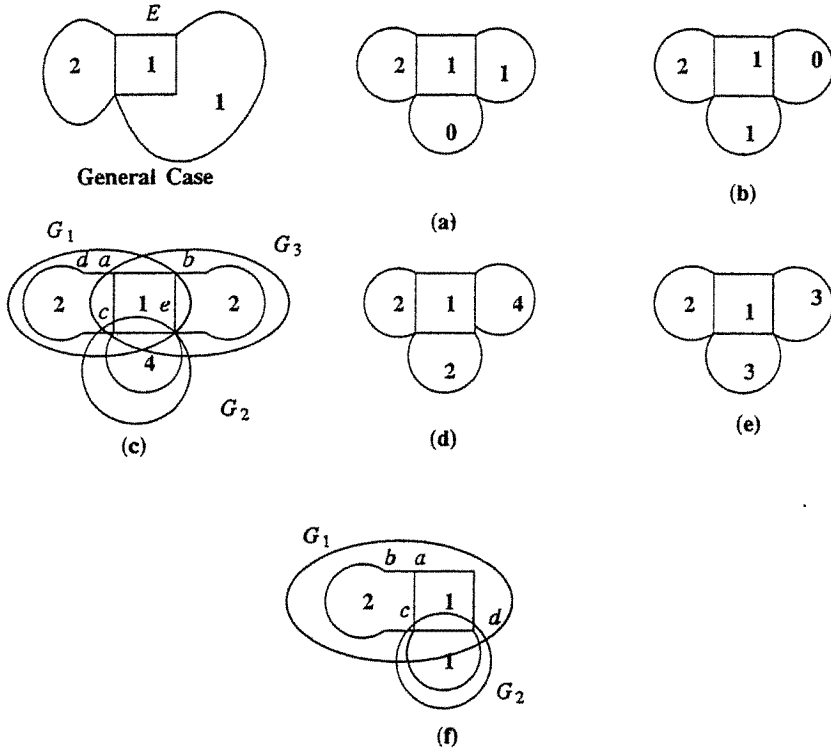

Figure 18: subcase 2c

Subcase 2d: $q_1 = (5k_1+3)$ and $q_2 + q_3 = (5k_2)$.

Partition the graph into two subgraphs, G_1 and G_2 . G_1 requires at most $(2k_1+1)$ guards and G_2 requires at most $2k_2$ guards. If any guard is placed at (a,b) , it can be

fixed easily as in previous cases.

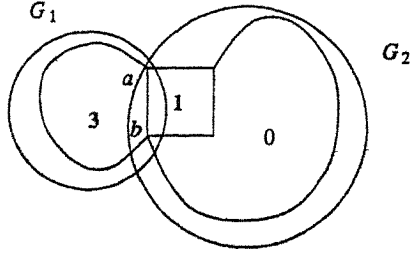

Figure 19: subcase 2d

Subcase 2e: $q_1 = (5k_1+4)$ and $q_2 + q_3 = (5k_2+4)$.

There are five possible cases. In case (a), partition the graph into two subgraphs, G_1 and G_2 . Apply the assumption and hypothesis, at most $(2k+1)$ guards are required. Case (b) is the same as subcase 2a. Case (c) is the same as subcase 2d and case (d) is the same as subcase 2b. For case (e), cut off G_1 and augment the remaining subgraph G_2 as shown. G_2 requires at most $(2k_2+2)$ guards. If the guard (a,b) exists, then it can be deleted by putting the vertex guard at b . Otherwise, the guard at c must exist. In the former case, append Q back to G_1 and the resulting subgraph will need at most $(2k_1+2)$ guards. In the latter case, place the vertex guard of E at a and apply the hypothesis to G_1 since both a and c are covered. Two other special cases, cases (f) and (g) when q_2 or q_3 is equal to 0. In case (f), assume a vertex guard can be put at either a or b and apply the hypothesis to G_1 . If the vertex guard is required at a , append Q to G_2 which requires at most $(2k_2+2)$ guards. The result follows. Otherwise, if the vertex guard is required at b , we put an additional guard at (b,c) and assign the vertex guard to d , apply the induction to G_2 . In case (g), assign the vertex guard at a and add a guard at (b,c) , apply induction to both subgraphs, G_1 and G_2 .

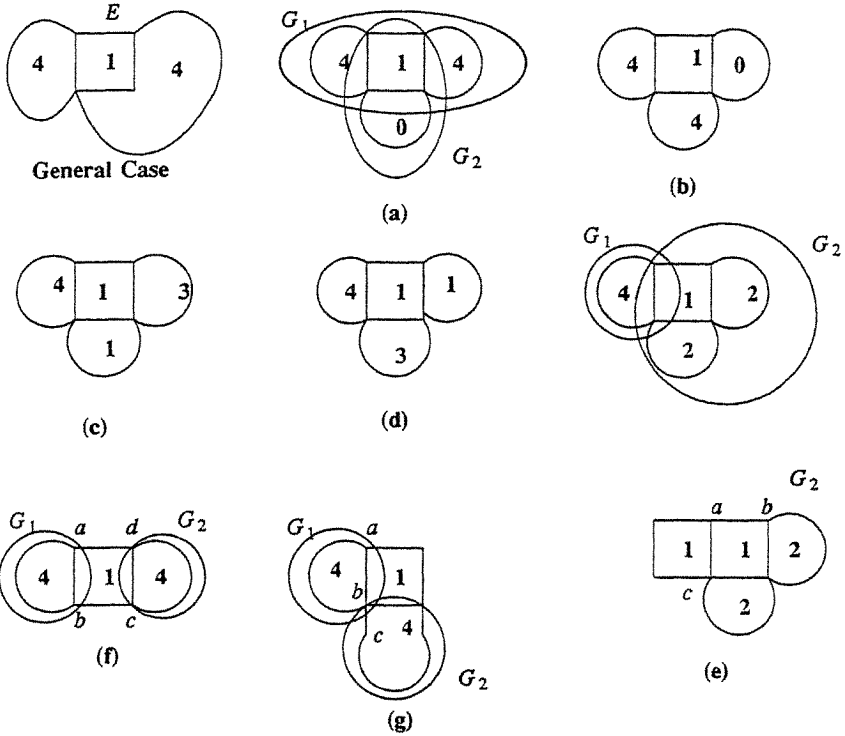

Figure 20: subcase 2e

Theorem: $\lfloor (2q+2)/5 \rfloor$ combinatorial edge guards are always sufficient to dominate any quad graph of a convex quadrilateralizable polygon for $q \geq 2$.

Proof: The proof is by induction on q , the number of quadrilaterals. If $q = 2$, then one guard suffices. Assume for all $q' < q$, $\lfloor (2q'+2)/5 \rfloor$ guards suffices. Lemma 3 shows that there exists a diagonal d that cuts off a minimum of 2, 3 or 4 quadrilaterals.

Case 1: 2 quadrilaterals are cut off.

After 2 quadrilaterals are cut off, the remaining graph will have $(q-2)$ faces. By the hypothesis, it can be dominated by $\lfloor [2(q-2)+2]/5 \rfloor$ guards. This gives $\lfloor (2q+2)/5 \rfloor - 1$ guards except when $q = 5k+1$. If D is assigned a guard, it can be replaced by another one easily since by lemma 3, one end of D can always share a node with a guard for the cut off part. Now consider the exceptional case:

The remaining portion will have $5(k-1)+4$ quadrilaterals. There are only two possible configurations for the cut off part. In either case, there exists an edge in the remaining part with either of its end points covered by the guard in the cut off part, so by lemma 5, the remaining portion can be dominated by an addition of $(2k+1)$ guards.

Case 2: 3 quadrilaterals are cut off.

In this case, the remaining quad graph will have only $(q-3)$ faces. By the hypothesis, it can be dominated by $\lfloor [2(q-3)+2]/5 \rfloor$ guards. If one of these guards is located at the diagonal D , it can be removed easily as shown in the following diagrams. So, $\lfloor (2q+2)/5 \rfloor$ edge guards are always sufficient.

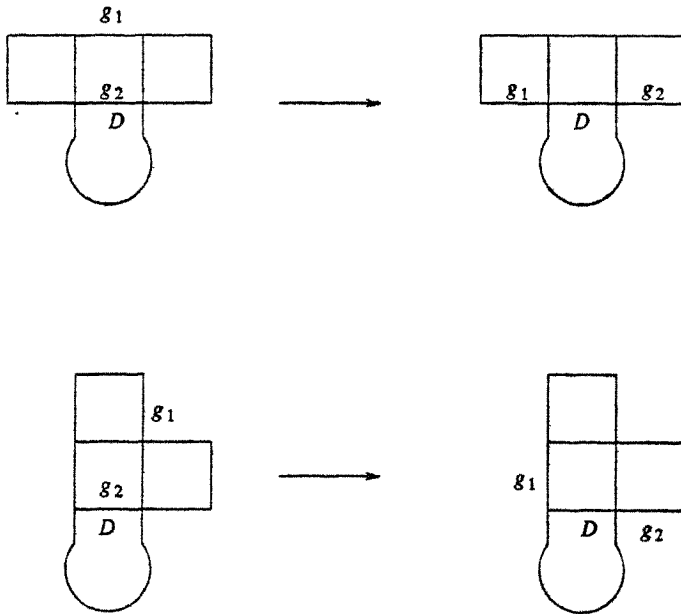

Figure 21: how to remove the guard at D

Case 3: 4 quadrilaterals are cut off.

Similarly in this case, the straight forward induction works except when $q = 5k+1$ or $5k+3$ where sharing with the edge guard for the cut off part is needed. Again, if a guard is placed at D , it can be easily replaced since by lemma 3, D always shares a vertex with a guard of the cut off part. Now consider the two exceptional cases. As shown in the graph, there is always a guard at either end of D which lies on an edge of the remaining graph.

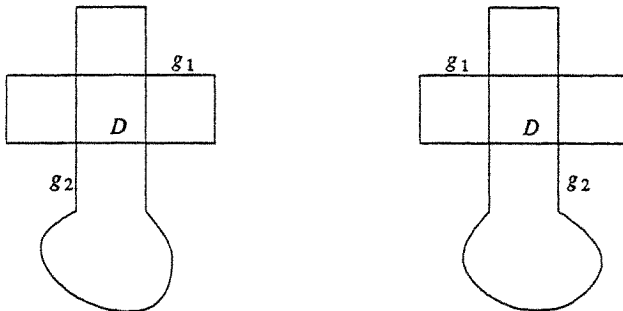

Figure 22: two possible locations of the guards for the cut off part

Subcase 1: $q = 5k+3$.

The remaining part of the graph will have $5(k-1)+4$ faces. By the above observation, the condition of lemma 5 is satisfied, so it can be dominated by an addition of $(2k-1)$ edge guards. Together with the two guards for the cut off part, at most $(2k+1)$ guards suffice.

Subcase 2: $q = 5k+1$.

In this case, the remaining subgraph will have $5(k-1)+2$ faces. Let M be the quadrilateral supported by D in the remaining subgraph, there will be three possible cases depending on the degree of M .

Subcase 2a: Degree of $M = 1$.

Let E be the diagonal connecting M to the rest of the subgraph. Cut through E , leave a subgraph with only $5(k-1)+1$ faces, by the induction hypothesis, it can be dominated by $(2k-2)$ guards. If E is assigned a guard, it can be replaced easily since one of the end point of E can always be shared by one guard of the cut off part. In other words,

$2k$ edge guards are sufficient to dominate the whole graph.

Subcase 2b: Degree of $M > 2$.

Let P_1, P_2 and P_3 be the subgraphs obtained by cutting off M and q_1, q_2 and q_3 be the number of quadrilaterals in P_1, P_2 and P_3 respectively.

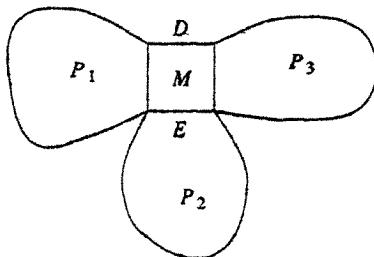

Figure 23: M is of degree > 2

Subcase 2b1: $q_1 = (5k_1)$ and $q_2 + q_3 = (5k_2+1)$

It can be further divided into five cases. Case (a) is the same as subcase 2b2. In case (b), partition the graph into three subgraphs, G_1, G_2 and G_3 . G_1 requires at most $2k_1$ guards. If (a,c) is assigned a guard, it can be deleted since the guard for the cut off part can be placed at (a,c) (please recall that one guard of the cut off part can be placed on the edge of the remaining graph as long as one of the end vertices of d is covered), similarly for G_3 . Therefore, if either (a,c) or (b,d) is assigned, one can be deleted. Otherwise, there must be guards at vertices e and f . In all cases, if (e,f) has been assigned in G_2 , it can be replaced by two edge guards in the former case and by one edge guard in the latter case. At most $2k$ edge guards are required. In case (c), place the guard for the cut off part at (b,d) . Apply lemma 5 to G_2 , the result follows easily. Case (d) is the same as subcase 2b4. Lastly, for case (e), the total number of guards required by three subgraphs is $2k+1$, one guard must be deleted otherwise we will spend one more guard. Similar to case (b), either one guard can be deleted in G_1 or G_3 or there must be guards at vertices e and f . In the former case, append M to G_2 to make sure no guard will be placed at (e,f) . In the latter case, apply lemma 5 to G_2 which requires one less guard since both vertices of (e,f) has been covered. There is a special case when $q_3 = 0$, case (f). Partition the graph as shown, and for G_1 , if the guard (a,b) exists, it can be replaced by the guard for the cut off part and if (c,d)

is assigned a guard in G_2 , it can be replaced by two edge guards at c and d . Otherwise, the guard at c must exist in G_1 , in this case, if (c,d) is assigned a guard, it can be replaced by one at d , the result follows easily.

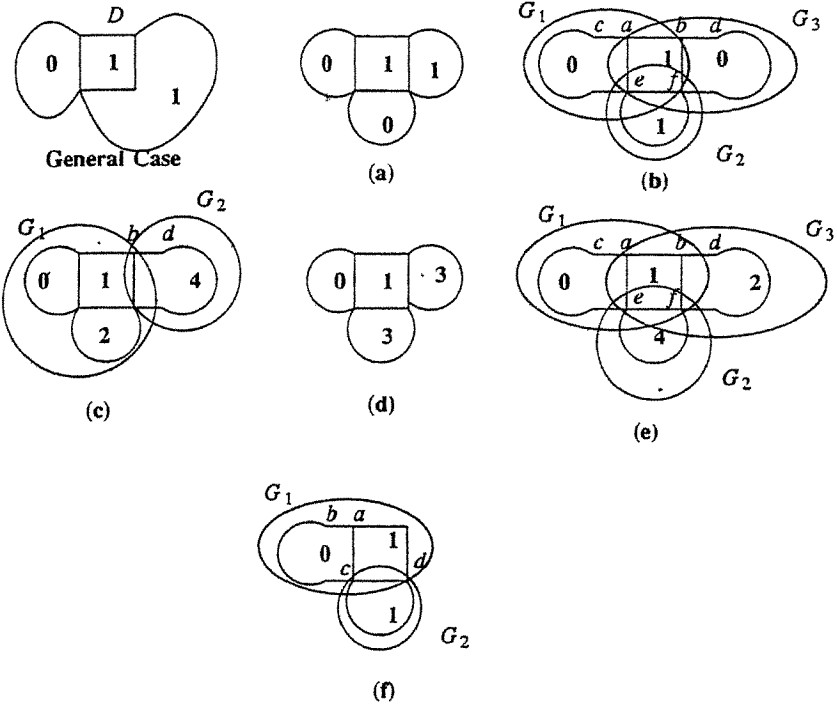

Figure 24: subcase 2b1

Subcase 2b2: $q_1 = (5k_1+1)$ and $q_2 + q_3 = (5k_2)$

Assign the guard of the cut off part at (a,c) and partition the graph into two sub-graphs, G_1 and G_2 . G_1 requires at most $2k_1$ guards without putting any in (a,e) since a has been covered (if a guard is placed at (a,e) , it can be replaced by one at vertex e). Altogether $2k$ edge guards are sufficient to dominate the whole graph.

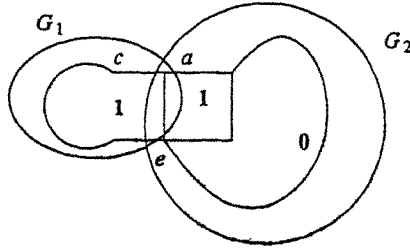

Figure 25: subcase 2b2

Subcase 2b3: $q_1 = (5k_1+2)$ and $q_2 + q_3 = (5k_2+4)$

There are five possible cases. Case (a) is the same as case(c) of subcase 2b1. Case (b) is the same as case (e) of subcase 2b1. Case (c) is the same as subcase 2b4. Case (d) is the same as subcase 2b2. In case (e), partition the graph into three subgraphs, G_1 , G_2 and G_3 . Apply lemma 4 to G_1 without putting any guard at (e,g) , and similarly apply lemma 4 to G_3 without putting any guard at (f,h) . So, either (a,c) or (b,d) exists and one can be deleted since the guard for the cut off part can be put at either (a,c) or (b,d) . Or both G_1 and G_3 need a guard at (e,f) . In this case, replace them by (e,i) and (f,j) . Since for G_2 , a guard must exist at (e,i) or (f,j) , so in G_2 , one guard can be deleted. In all cases, one guard can be deleted, so at most $2k$ guards are needed. Lastly, there is a special case when $q_3 = 0$, case (f). In this case, G_1 will either have a guard at (a,c) , so it can be deleted or have a guard at e . In the latter case, place the guard for the cut off part at (b,d) , apply lemma 5 to G_2 since e and d are covered, the result follows.

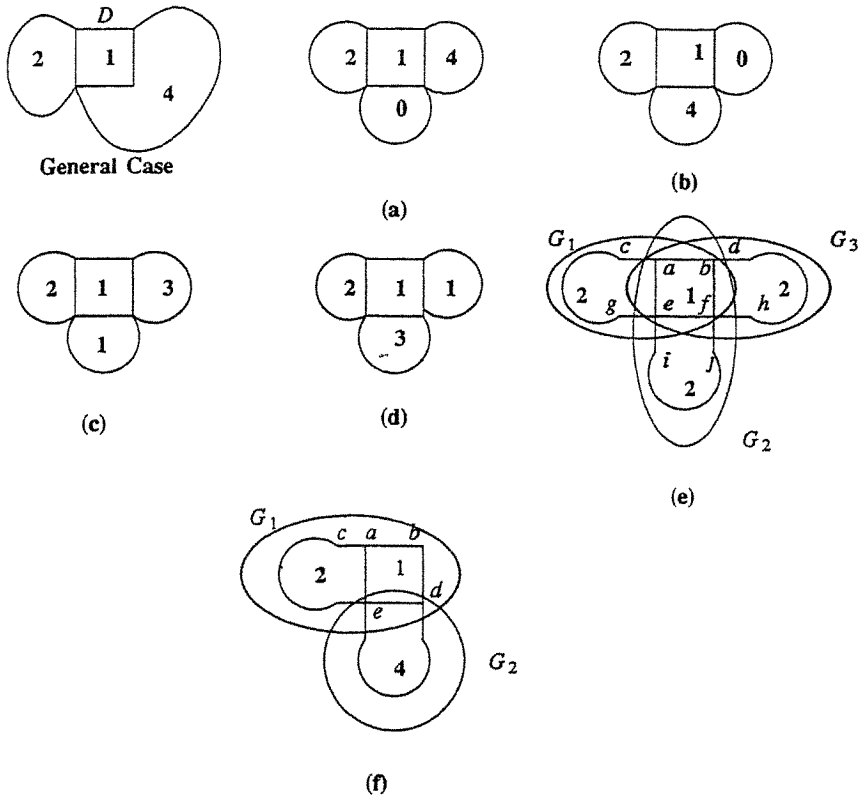

Figure 26: subcase 2b3

Subcase 2b4: $q_1 = (5k_1+3)$ and $q_2 + q_3 = (5k_2+3)$

Partition the graph into G_1 and G_2 as shown. Apply lemma 4 to G_1 without putting any guard at (a,e) . Place the guard for the cut off part at (b,d) and apply lemma 5, so at most $2k$ guards are needed.

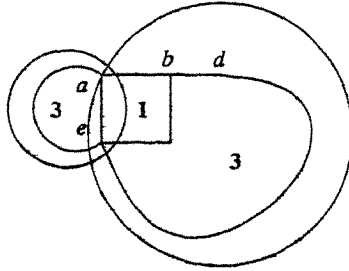

Figure 27: subcase 2b4

Subcase 2b5: $q_1 = (5k_1+4)$ and $q_2 + q_3 = (5k_2+2)$

This case is exactly the same as case (c) of subcase 2b1.

Corollary: $\lfloor n/5 \rfloor$ combinatorial edge guards are always sufficient to dominate any quad graph of an orthogonal polygon.

Proof: It has been proved that orthogonal polygons are convexly quadrilateralizable [1], so the result follows easily.

Acknowledgements:

I would like to thank my supervisor, Dr. Andrew Choi, for his careful reading of the manuscript and his very helpful comments and discussions which not only make some of the ideas clearer, but also improve the readability of the paper.

References:

- [1] J. O'Rourke, *Art Gallery Theorems and Algorithms*, Oxford University Press, 1987.
- [2] T. Shermer, *Several Short Results in the Combinatorics of Visibility*, Technical Report CMPT TR-91-02, Simon Fraser U., May 1991.

X08964991

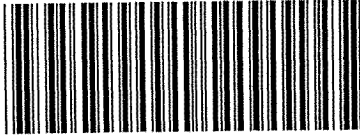

XP 511.6 Y51

Yiu, S. M.

A tight bound for
combinatorial edge guards in
orthogonal polygons

Hong Kong : Department of
Computer Science, Faculty of

