



<b>Title</b>	<b>Transfer capability computations in deregulated power systems</b>
<b>Author(s)</b>	<b>Shaaban, MMAM; Ni, Y; Wu, FF</b>
<b>Citation</b>	<b>The 33rd Annual Hawaii International Conference on System Sciences Proceedings, 4-7 January 2000</b>
<b>Issued Date</b>	<b>2000</b>
<b>URL</b>	<b><a href="http://hdl.handle.net/10722/46206">http://hdl.handle.net/10722/46206</a></b>
<b>Rights</b>	<b>Creative Commons: Attribution 3.0 Hong Kong License</b>

## Transfer Capability Computations in Deregulated Power Systems

Mohamed Shaaban (St. M. IEEE)

Yixin Ni (S. M. IEEE)

Felix F. Wu (Fellow, IEEE)

Center for Electrical Energy Systems  
Department of Electrical and Electronics Engineering  
The University of Hong Kong  
Hong Kong

### ABSTRACT

With the recent trend towards deregulating power systems around the world, transfer capability computation emerges as the key issue to a smoothly running power market with multiple transactions. Total transfer Capability (TTC) is the basic measure for evaluating Available transfer capability (ATC). This paper presents the calculation of TTC through an optimal power flow approach. The objective function is to maximize the sum of the sending end-end generation and receiving-end load of specified buses. The constraints are ac power flow equations and system operation limits. Sequential Quadratic Programming (SQP) method is used for the optimization process. IEEE 30 bus system is used for testing the proposed algorithm and the results compared favorably with that from the Continuation Power Flow (CPF) method.

*Keywords:* Electric power deregulation, total transfer capability, optimal power flow.

### 1. INTRODUCTION

The concept of competitive industries rather than regulated ones has become prominent in the past few years. Economists and political analysts have promoted the idea that free markets can drive down costs and prices thus reducing inefficiencies in power production. This change in the climate of ideas has fostered regulators to initiate reforms to restructure the electricity industry to achieve better service, reliable operation, and competitive rates. Deregulation of the power industry was first initiated in United Kingdom, followed suit in Norway and Australia.

The U.S. electricity industry has reportedly taken the plunge towards deregulation. The Federal Energy Regulatory Commission (FERC), recognizing the centrality of open transmission to real competition, has mandated that transmission must be open to all comers. FERC, in conjunction with North American Electric Reliability Council (NERC), endorsed the exchange of transmission service information through Open Access Same-Time Information Network (OASIS). One of the main functions of the OASIS is to post Available Transfer Capability (ATC) information [1]

Available transfer capability (ATC) is the measure of the ability of interconnected electric systems to reliably move or transfer power from one area to another over all transmission lines or paths between those areas under specified system conditions. It is clear that ATC information is significant to the secure operation of deregulated power systems as it reflects physical realities of the transmission system such as customer demand level, network paradigm, generation dispatch and transfer between neighboring systems. In order to obtain ATC, the total transfer capability (TTC) should be evaluated first where TTC is the largest flow through selected interfaces or corridors of the transmission network which causes no thermal overloads, voltage limit violations, voltage collapse or any other system problems such as transient stability. Other parameters involved in ATC calculations are the Transmission Reliability Margin (TRM) and Capacity Benefit Margin (CBM) [1]. However, since dedicated methodologies for determining TRM and CBM may vary among regions, sub-regions, and power pools, this paper addresses the calculation of TTC as the basis of ATC evaluation.

One of the most common approaches for transfer capability calculations is the continuation power flow (CPF) [2, 3]. CPF is a general method for finding the maximum value of a scalar parameter in a linear function of changes in injections at a set of buses in a power flow problem. In principle, CPF increases the loading factor in discrete steps and solves the resulting power flow problem at each step. CPF yields solutions at voltage collapse points. However, since CPF ignores the optimal distribution of the generation and the

loading together with the system reactive power, it can give conservative transfer capability results.

This paper features an OPF-based procedure for calculating the total transfer capability (TTC). The method is based on full AC power flow solution which accurately determines reactive power flow, and voltage limits as well as the line flow effect. The objective function is to maximize total generation supplied and load demand at specific buses. The mathematical formulation of the proposed method is presented and the algorithm is tested on the IEEE 30 bus system to show its capability.

## 2. PROBLEM FORMULATION

The OPF-based TTC calculation algorithm described below enables transfers by increasing the load, with uniform power factor, at a specific load bus or every load bus in the sink control area, and increasing the real power injected at a specific generator bus or several generators in the source control area until limits are incurred. The main assumptions for this method are [5]:

- A current state estimation of the power system is available and the operating point is secure and stable.
- The system is properly controlled and can provide enough damping to keep steady-state stability.
- The system has sufficiently large stability margin; hence it can survive disturbances and shift to another stable operating point.
- System voltage limit is reached before the system loses voltage stability.

Only thermal limits and bus voltage limits are considered as well as generator active and reactive power limits.

Mathematically, TTC calculation problem can be represented as:

$$\begin{aligned} & \text{Maximize} && J = f(x, u) \\ & \text{s.t.} && \\ & && g(x, u) = 0; \\ & && h^{\min} \leq h(x, u) \leq h^{\max} \end{aligned} \quad (1)$$

Where  $f(x, u)$  is the objective function,  $x$  represents the system state variable vector and  $u$  the control parameter vector.  $g(x, u)$  is the equality constraint function vector and  $h(x, u)$  the inequality constraint function vector. The cost function  $J$  is defined to be the sum of total generation of a specific generator or a group of generators (designated as  $S$ ) and total load of a specific load bus or a cluster of load buses (designated as  $R$ ), i.e.

$$J = \sum_{k \in S} P_{Gk} + \sum_{d \in R} P_{Ld} \quad (2)$$

Where  $P_{Gk}$  is the generation at bus  $k$  and the  $P_{Ld}$  is the load at bus  $d$ .

The  $g(x, u) = 0$  is the power flow equality constraint which is described [ 6]:

$$\begin{aligned} \phi_P &= P_i - V_i \sum_{j=1}^N V_j (G_{ij} \cos \theta_{ij} + B_{ij} \sin \theta_{ij}) = 0 \\ \phi_Q &= Q_i - V_i \sum_{j=1}^N V_j (G_{ij} \sin \theta_{ij} - B_{ij} \cos \theta_{ij}) = 0 \\ i &\neq \text{ref. bus}, \theta_{\text{ref}} = 0 \end{aligned} \quad (3)$$

Where  $P_i, Q_i$  are the active and reactive power injection at bus  $i$ ;  $V_i \angle \theta_i$  is the voltage at bus  $i$  and  $\theta_{ij} = \theta_i - \theta_j$ ;  $G_{ij} + jB_{ij}$  is the corresponding element in system Y-matrix. The power injection at bus  $i$  is defined as

$$P_i = P_{Gi} - P_{Li}, \quad Q_i = Q_{Gi} - Q_{Li} \quad (4)$$

Where  $P_{Gi}$  and  $Q_{Gi}$  are the real and reactive power generation at bus  $i$ , while  $P_{Li}$  and  $Q_{Li}$  the real and reactive load at bus  $i$ . With bus voltages magnitudes, including the Ref. Bus, and bus voltage phase angles, except the Ref. Bus where  $\theta_{\text{Ref}} = 0$ , are taken as state variables  $x$ , It is evident that if a set of  $u$  is given  $x$  can be solved from Eq. (3).

The inequality constraints are as follows,

(a) The generation and load limits:

$$\begin{aligned} P_{Gk}^{\min} &\leq P_{Gk} \leq P_{Gk}^{\max} \quad (k \in S) \\ Q_{Gi}^{\min} &\leq Q_{Gi} \leq Q_{Gi}^{\max} \\ 0 &\leq P_{Ld} \leq P_{Ld}^{\max} \quad (d \in R) \end{aligned} \quad (5.a)$$

Where  $P_{Gk}^{\max}$  and  $P_{Gk}^{\min}$  are the upper and lower limits of the generator active power at bus  $k$ .  $Q_{Gi}^{\max}$  and  $Q_{Gi}^{\min}$  are reactive power limits for generator  $i$ .  $P_{Ld}^{\max}$  is the upper limit of the of the load active power which is constrained by distribution facility capacity.

(b) The bus voltage limits applied to all buses in the network:

$$V_i^{\min} \leq V_i \leq V_i^{\max} \quad (5.b)$$

(c) The current limits of transmission lines based on thermal considerations:

$$0 \leq I_{ij} \leq I_{ij}^{\max} \quad (5.c)$$

Where  $I_{ij}$  and  $I_{ij}^{\max}$  are the actual and maximum current of line  $i-j$  respectively.  $I_{ij}$  can be calculated from  $V_i, V_j$  and parameters of line  $i-j$ . Equations (1) to (5) constitute the mathematical model of the OPF-based TTC computation. In this study, the system state variables are:

- Voltage magnitudes and phase angles of all buses except Ref. bus phase angle which is set to be zero.

The control variables are:

- Real power output of generator  $k$  ( $P_{Gk}$ ),  $k \in S$ .
- Real power of load  $d$  ( $P_{Ld}$ ),  $d \in R$ .
- Reactive power of each generator ( $Q_{Gi}$ ).

### 3. OPTIMIZATION

The advanced Sequential Quadratic Programming (SQP) method is selected to solve the TTC-OPF problem since it was recently developed and proven to be an effective method for constrained nonlinear programming [7].

For the general purpose optimization problem in the form given as (here both  $x$  and  $u$  in Eq. (1) are considered as  $x$ ):

$$\begin{aligned} & \text{Min } f(x) \\ & \text{s.t.} \\ & g_i(x) = 0 \quad (i = 1, 2, \dots, p) \\ & h_j(x) \leq 0 \quad (j = 1, 2, \dots, m) \end{aligned} \quad (6)$$

The corresponding Lagrangian function  $L(x, \lambda)$  is formed as

$$L(x, \lambda) = f(x) + \sum_{i=1}^p \lambda_i g_i(x) + \sum_{j=1}^m \lambda_{p+j} h_j(x) \quad (7)$$

Where  $\lambda_i$  ( $i=1,2,\dots,(p+m)$ ) is the Lagrange multiplier for the active  $i$ th equality and inequality constraint. We can define a corresponding approximate quadratic programming sub-problem. It can be proven that the QP sub-problem at the  $k$ -th iteration is equivalent to another QP sub-problem defined as:

$$\begin{aligned} & \text{Min } \nabla f(x^k)^T s + 0.5s^T [H_k] s \\ & \text{s.t.} \\ & g_i(x^k) + \nabla g_i(x^k)^T s^k = 0 \quad (i = 1, 2, \dots, p) \\ & h_j(x^k) + \nabla h_j(x^k)^T s^k \leq 0 \quad (j = 1, 2, \dots, m) \end{aligned} \quad (8)$$

Where  $[H_k]$  is a positive definite matrix that is taken initially as an identity matrix and updated in subsequent iterations so as to converge to the real Hessian matrix of the Lagrangian function of Eq. (7) which will be explained below. The vector  $s^k$  to be optimized is served as the search direction, i. e.

$$x^{k+1} = x^k + \alpha^k s^k \quad (9)$$

Where  $\alpha$  is the optimal step length along the search direction  $s^k$  found by minimizing the merit function [7]:

$$\text{Min. } f(x^{k+1}) + \sum_{i=1}^p \lambda_i g_i(x^{k+1}) + \sum_{j=1}^m \lambda_{p+j} \cdot \max[0, h_j(x^{k+1})] \quad (10)$$

The update of the Hessian matrix  $H$  after the  $k$ -th iteration to improve the quadratic approximation is given as [7]

$$H_{k+1} = H_k - H_k^T d_k d_k^T H_k / (d_k^T H_k d_k) + \gamma \gamma^T / (d_k^T d_k)$$

where

$$\begin{aligned} d_k &= x^{k+1} - x^k \\ \gamma &= \theta Q_k + (1 - \theta) H_k d_k \end{aligned}$$

$$Q_k = \nabla_x L(x^{k+1}, \lambda^{k+1}) - \nabla_x L(x^k, \lambda^k) \quad (11)$$

$$\theta = \begin{cases} 1.0 & \text{(if } d_k^T Q_k \geq 0.2 d_k^T H_k d_k) \\ \frac{0.8 d_k^T H_k d_k}{d_k^T H_k d_k - d_k^T Q_k} & \text{(otherwise)} \end{cases}$$

Where  $L$  is given by Eq. (7) and the constants 0.2 and 0.8 can be changed based on numerical experience.

Using the above mentioned equations, TTC calculation procedure can be summarized as follows:

- Step 1: Calculate base load flow to get  $x^{(0)}$  and assume initially the Hessian matrix is unity
- Step 2: Evaluate the gradients of the objective function and constraint functions
- Step 3: Solve QP sub-problem in Eq. (8) to get optimal search direction  $s$
- Step 4: Find optimal step length  $\alpha$  and update  $x$  by Eq. (9)
- Step 5: Update the Hessian matrix  $[H]$  by Eq. (11)
- Step 6: Check convergence. If it is converged, then output results and stop; otherwise go to step 2 to next iteration.

### 4. IEEE 30 BUS TEST RESULTS

The IEEE 30-bus system, shown in Figure 1, is adopted as the test system. The system has 3 areas with 2 generators in each area. Generators in each area are assumed to belong to the same owner and the loads belong to the same load serving entity. Transactions between different control areas are investigated, i.e., TTC will be evaluated between areas. The base load flow is given in the Appendix. Some buses retain low voltage profile like buses 7, 8, and 19, while line 6-8 is more than 90% loaded. Several cases are studied with three case results presented below.

*Case 1: the transfer capability from area 2 to area 1*

Using the proposed OPF-based TTC method, the generation of area 2 increases from 56.2 MW to 70.0 MW and the load at area 1 from 84.5 MW to 99 MW. The loads are modeled as a constant power factor load. The active loading vector of area 1, excluding intermediate or zero loading buses, after and before this transaction is shown in table 1. TTC is 99 MW and the limit was the overloading of line 21-22. Since the objective function maximizes the total generation in area 2 and the total load in area 1, both the generation and load increments are not uniformly distributed in each area. Hence, using a common loading factor, typically of CPF method, might lead to in a conservative TTC results due to the improper allocation of generations and loads. EPRI Voltage STABILITY (VSTAB) [8]

was utilized for calculating the transfer between area 2 and 1 by CPF. TTC calculated with CPF is 88.5 MW which is more conservative than the one obtained by the proposed method. The overload of line 6-8 was the limiting condition using CPF. Clearly CPF incremented the load with only 5 MW that was enough to trigger the overload in line 6-8 which was almost fully loaded before this transaction occurs.

*Case 2: the transfer capability from area 3 to area 1*

The loads in area 1 increase gradually with the generation of area 3 increased accordingly. The proximity of lines 21-22, 5-23, and 6-8 to be overloaded were the limiting condition in this case. Using the suggested method, the generation at area 3 is increased from 48.5 MW to 94.9 MW while the load at area 1 is increased from 84.5 MW to 129.5 MW. TTC is found to be 129.5 MW. Continuation power flow results was 89.5 MW when line 6-8 is 2% overloaded. The discrepancy between TTC results of both methods is significant particularly for this case. VSTAB scales up the generation in the same loading direction regardless of limits imposed on line 6-8 but the proposed OPF method identifies that instantly and redispaches power generation and load distribution of specified sources and sinks as well as reactive power generation to avoid any overloading or other violations.

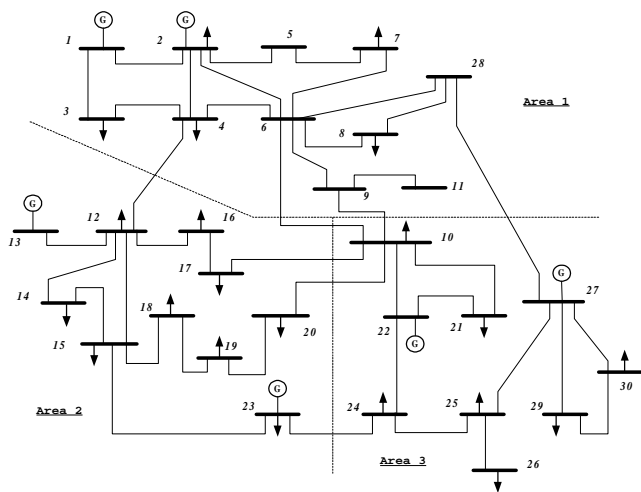

Figure 1. IEEE 30-bus system

Table 1. Active loading of area 1 in MW for a transaction between area 2 and area 1

Bus #	2	3	4	7	8
Before	21.7	2.4	7.6	22.8	30.0
After	36.25	2.4	7.6	22.8	30.0

*Case 3: the transfer capability from area 3 to area 2*

The transfer capability between area 3 and area 2 is 107 MW using the proposed technique. The overload that took place in line 25-27 hindered the algorithm

from further increase in the specified transfer. The load active power vector of area 2 in bus number sequence is [39.72, 0.0, 6.2, 8.2, 3.5, 9.0, 3.2, 9.5, 2.2, 25.48] MW. The loads on bus 12 and bus 23 are the only ones to experience an increase during the optimization process. The increase of loads is extremely non-uniform. TTC calculated using CPF is much less than its counterpart using the proposed OPF method. TTC equals to 61 MW by CPF because of the overload of line 21-22. The critical load of area 2 of the nose point for that case is 257 MW with 22 voltage violations and 15 line overloads. This confirms again that the system usually hits the operation limits at a much lower loading condition than it hits the nose point. This result justifies the assumption made in earlier section.

In these tests, the developed program converges very well in OPF calculation since it uses Newton’s method in solving nonlinear equations and starts from a steady state operating point. However it should be pointed out that SQP method has the possibility of converging to a local minimum/maximum especially in a highly nonlinear system. Therefore further tests on stressed and ill-conditioned systems are required.

**5. CONCLUSION**

A new formulation for OPF to calculate the Total Transfer Capability TTC is reported in this paper. The objective function is the total generation and load increase on specific source and sink nodes. The thermal limits of transmission lines, voltage bounds of buses, and upper and lower limits of generator power are considered as well as load flow equations. The advanced sequential quadratic programming method is extended for TTC calculation. An algorithm has been developed and tested on the IEEE 30-bus system. Computer results show that the proposed method is very effective, and with good convergence characteristics as well, in determining TTC. The main conclusions of the paper are:

- The proposed OPF-based TTC algorithm works well in determining TTC between different areas subject to system operation limits.
- OPF-based TTC approach can re-dispatch generator reactive power outputs and optimally distribute the increment of loads and generations on the specific buses, therefore it can reach the maximum TTC, while The CPF technique usually gives a conservative estimation of TTC for the lack of the optimization function.

**ACKNOWLEDGEMENT**

The authors would like to thank EPRI, USA for their kind donation of VSTAB software for our academic research.

**REFERENCES**

- [1] Transmission Transfer Capability Task Force, "Available Transfer Capability Definitions and Determination", North American Electric Reliability Council, Princeton, NJ, June 1996.
- [2] V. Ajjarapu and C. Chrity, "The Continuation Power Flow: A Tool for Steady State Voltage Stability Analysis", *IEEE Transactions on Power Systems*, Vol. 7, No. 1, pp. 416-423, February 1992.
- [3] H. D. Chinag, A. J. Flueck, K. S. Shah and N. Balu, "CPFLOW: A practical Tool for Tracing Power System Steady-State Stationary Behavior Due to the Load and Generation Variations", *IEEE Transactions on Power Systems*, Vol. 10, No. 2, pp. 623-634, May 1995.
- [4] G. C. Ejebe, J. Tong, J. G. Waight, J. G. Frame, X. Wang and W. F. Tinney, "Available Transfer Capability Calculations", *PE-321-PWRS-0-10-97*.
- [5] M. Shaaban, Y. Ni, H. Dai and F. Wu, "Considerations in Calculating Total Transfer Capability", *Proc. Of the International Conference on Power System Technology*, Beijing, Vol. 2, pp. 1356-1360, August 1998.
- [6] A. J. Wood and B. F. Wollenberg, "Power Generation, Operation, and Control", *John Wiley & Sons*, 2nd edition, 1996.
- [7] S. S. Rao, "Engineering Optimization: Theory and Practice", *John Wiley & Sons*, 3rd edition, 1996.
- [8] Powerch Labs Inc., "Voltage Stability Analysis Program (VSTAB) User's Manual", *Prepared for EPRI, USA*, 1997.

**APPENDIX**

IEEE 30 bus system data

Total load of area 1 = 84.5 MW  
 Total load of area 2 = 56.2 MW  
 Total load of area 3 = 48.5 MW

Current generation of area 1 = 87 MW  
 Current generation of area 2 = 56.2 MW  
 Current generation of area 3 = 48.5 MW  
 Available generation of area 1 = 160 MW  
 Available generation of area 2 = 70 MW  
 Available generation of area 3 = 105 MW

The operating point of the 30-bus system (P/Q: MVA)

Bus No.	Area No.	V (p.u.)	Angle (deg.)	Generation		Load	
				P	Q	P	Q
1	1	1.00	0.0	26.03	0.0	0.0	0.0
2	1	1.00	-0.42	60.97	38.57	21.7	12.7
3	1	0.98	-1.50	--	--	2.4	1.2
4	1	0.98	-1.77	--	--	7.6	1.6
5	1	0.98	-1.82	--	--	0.0	0.0
6	1	0.97	-2.24	--	--	0.0	0.0
7	1	0.96	-2.61	--	--	22.8	10.9
8	1	0.96	-2.70	--	--	30.0	30.0
9	1	0.98	-2.97	--	--	0.0	0.0
10	3	0.98	-3.35	--	--	5.8	2.0
11	1	0.98	-2.97	--	--	0.0	0.0
12	2	0.99	-1.51	--	--	11.2	7.5
13	2	1.00	1.50	37.0	11.69	0.0	0.0
14	2	0.98	-2.28	--	--	6.2	1.6
15	2	0.98	-2.29	--	--	8.2	2.5
16	2	0.98	-2.62	--	--	3.5	1.8
17	2	0.98	-3.37	--	--	9.0	5.8
18	2	0.97	-3.46	--	--	3.2	0.9
19	2	0.96	-3.93	--	--	9.5	3.4
20	2	0.97	-3.85	--	--	2.2	0.7
21	3	0.99	-3.47	--	--	17.5	11.2
22	3	1.00	-3.38	21.59	40.34	0.0	0.0
23	2	1.00	-1.58	19.2	8.13	3.2	1.6
24	3	0.99	-2.62	--	--	8.7	6.7
25	3	0.99	-1.67	--	--	0.0	0.0
26	3	0.97	-2.12	--	--	3.5	2.3
27	3	1.00	-0.81	26.91	10.97	0.0	0.0
28	1	0.97	-2.25	--	--	0.0	0.0
29	3	0.98	-2.11	--	--	2.4	0.9
30	3	0.97	-3.02	--	--	10.6	1.9