



<b>Title</b>	<b>Multi-access radio resource management using multi-agent system</b>
<b>Author(s)</b>	<b>Feng, Z; Yu, K; Ji, Y; Zhang, P; Li, VOK; Zhang, Y</b>
<b>Citation</b>	<b>Ieee Wireless Communications And Networking Conference, Wcnc, 2006, v. 1, p. 63-68</b>
<b>Issued Date</b>	<b>2006</b>
<b>URL</b>	<b><a href="http://hdl.handle.net/10722/45940">http://hdl.handle.net/10722/45940</a></b>
<b>Rights</b>	<b>Creative Commons: Attribution 3.0 Hong Kong License</b>

# Multi-access Radio Resource Management using Multi-Agent System

FENG Zhiyong<sup>1</sup>, YU Kai<sup>1</sup>, JI Yang<sup>1</sup>, ZHANG Ping<sup>1</sup>, Victor O.K. Li<sup>2</sup>, ZHANG Yongjing<sup>1</sup>

(1. WTI Labs, Beijing University of Posts and Telecommunications, Beijing 100876, China;

2. Multimedia Networking Lab, Department of Electrical and Electronic Engineering, University of Hong Kong, Hong Kong, China)

**Abstract**—Coexistence of heterogeneous networks such as cellular, Wireless Local Area Network (WLAN), Ultra-wideband (UWB) etc. brings new challenges. It is perceived that current radio resource management mechanism cannot meet the requirements of multi-radio access technologies (Multi-RATs). This paper proposes a novel intelligent multi-agent radio resource management system, which is self-organized and distributed to ensure the coexistence of Multi-RATs. Radio resource is managed by a macro control and management system using control factors and validation mechanism, instead of micro control for individual users. The goal is to increase radio resource utilization efficiency, maximize system capacity and meet the QoS requirements of different services.

**Keywords** - multi-access radio networks; coexistence; Multi-Agent; control factors; intelligent

## I. INTRODUCTION

A Beyond 3G network is characterized by the efficient integration of multiple radio access technologies in a common network, and terminals with reconfigurable capabilities, thus imposing new requirements on the radio resource management (RRM). Conventional RRM cannot cope with the increasing demands imposed by both networks and users. Consequently, fueled by the successive emergence of different radio access technologies in the last few years, researchers are contemplating new concepts such as ubiquitous computing, nomadic access, and seamless service, leading to best service experience to mobile subscribers.

Multi-access radio resource management (MRRM) has come into the spotlight only in the last three years. Existing research efforts are mostly focused on centralized management, which means that one or more central entities coordinate different RAT-specific RRM entities. In [1] and [2], 3GPP has discussed and standardized common radio resource management (CRRM), where GSM and EDGE as well as Wideband CDMA (WCDMA) are managed in an integrated fashion through the CRRM server. In [3]-[5], Joint Radio Resource Management (JRRM) is presented by Siemens. The core concepts of this management system are “service-split” and “multi-homing”. JRRM splits the service into fundamental part and enhanced part and the former is delivered by RAT with large coverage range, e.g. UMTS, while the latter by RAT with high bandwidth, e.g. HIPERLAN/2.

From the perspective of future business development, however, the centralized RRM mode is unrealistic, since a

central management entity coordinating RATs is required. It should be noted that existing and emerging RATs will be operated by different network providers (NPs) in the future. Generally, NPs do not share information regarding the exact structure of their networks, especially the cell layout. Therefore, it is unnecessary and impossible to establish a central management entity to coordinate the heterogeneous networks.

An alternative solution is adopting distributed Multi-access Radio Resource Management mode. In [6], the relationship of distributed networks is discussed and a comparison between centralized and distributed modes is presented. However, the detailed procedure is not available in this paper. In [7], the application of computational intelligence (CI) technologies for the development of appropriate, sophisticated new service and network resource management systems for composite radio environments (SNRMS-CRE) is defined, but deployment of CI is not discussed in detail. In [8], the functional components of the management system for composite radio environments (MS-CRE) are introduced, as the evolution of SNRMS-CRE in [7].

An analysis of the state-of-the-art MRRM in heterogeneous networks reveals that almost all efforts attempt to construct the management platform or design new mechanisms to improve the network-centric performance. Most of them handle the detailed RRM decisions concerning individual users or cells, thus increasing the network loading significantly. In the meantime, an important issue, the coexistence of Multi-RATs in the same geographical area, is neglected. In the future, each RAT should possess a certain market share, since each technology is tailored to reach a particular market, or particular type of user with specific service need. Therefore, a question naturally arises: how does one guarantee the coexistence of different RATs?

To address the aforementioned unresolved problem, this paper proposes a novel distributed intelligent Multi-Agent System (MAS), which is self-organized to solve the problem due to the coexistence of multi RATs operated by different NPs. Compared with the issues addressed by the existing JRRM, MAS is mainly concerned with the coexistence of different RATs in a specific geographical area. The agent performs a macro control and management function by using control factors and validation mechanism instead of micro control handling detailed RRM decisions concerning individual users. The purpose of this paper is to discuss the architecture of the distributed intelligent MAS and the main mechanism.

<sup>1</sup>This research is supported by the NSFC/RGC Joint Research Scheme, Project No. 60318004, N\_HKU706/03 and National 863 High Tech Program of China, No. 2004AA119030.

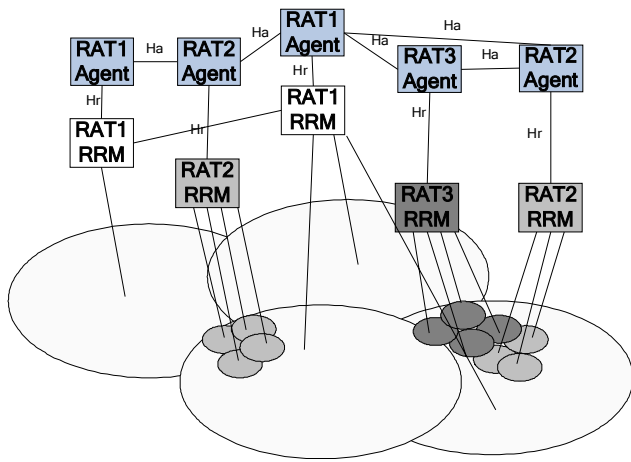

Figure 1. Multi-agent system architecture model

The rest of this paper is organized as follows. Section II presents MAS, including the system infrastructure and agent relation to other RAN functions. Section III details the different functions of the agent, involving the specific function of the cognitive layer, reaction layer and memory layer. In Section IV, the work flow between different agents is introduced. Section V concludes this paper.

## II. MULTI-AGENT SYSTEM

This section presents the architecture of the Multi-Agent System and its mechanism. The network deployment and the corresponding relations with specific protocol stacks are also described.

### A. Network architecture

The Multi-Agent System is illustrated in Fig. 1 with three kinds of radio access networks. The MRRM functions are performed by the agent, which is isolated from the RAT-specific RRM functions. Only the pair of agents that handle overlapping cells needs to have a peer-to-peer relation. The agent is responsible for collecting the status information of the underlying specific RAT and the information of neighboring agents. Based on the obtained information, the agent deals with the coexistence-related issues, including optimization of the Objective Function (OF) of the local network and satisfaction of the Boundary Function (BF) of the neighboring network, and inter-network handover. On the one hand, according to OF, the adjustment performed by the agent can overcome adverse situation (e.g. overload). On the other hand, according to BF, the adjustment can guarantee the coexistence of both RATs. In other words, the adjustment will not cause destructive effects on neighboring RAT.

As for deployment, taking WCDMA for example, one agent can control one Radio Network Subsystem (RNS) or several RNSs according to the specific traffic volume of the geographical area. It should be noted that the agent is a logical entity. Therefore, the agent can be a standalone server or be integrated into other existing management entities, e.g. RNC. With respect to granularity, since the user distribution and service traffic of each cell differ from others, the agent collects

the status information and performs adjustment on a cell basis. Regarding cost, the agent is required only in the scenario where the two RATs overlap with each other in the same geographical area.

The relationship between agents is self-organized. Each agent has cooperative capabilities and competitive capabilities, trying to maximize the outcome of a specific objective. However, the global objective of the system is achieved through the collaboration of all agents.

### B. The basic entities and interfaces

The key element in the architecture shown in Fig. 1 is the agent, which is a new functional component to support multi-access radio resource management. The agent performs all the resource management and control functions for radio networks with overlapping cells. The agent is an intelligent element, which collects the information both from the radio network under its control and from other agents. It can actively search cells overlapped with other radio networks and actively detects whether it is necessary to trigger resource adjustment according to the received information. When performing resource adjustment, the agent not only considers the requirement of the local network, but also the requirements of networks with overlapping cells. The agent performs macro control by using control factors and validation mechanism.

The involved interfaces illustrated in Fig. 1 are briefly discussed below.

**Hr:** This interface is used to carry information between the RAT and the corresponding agent. Through this interface, an agent collects radio network information such as parameters related to radio resource, parameters about performance, etc., and sends control factors to the RAT.

**Ha:** The Agent-Agent interface is used to carry information concerning:

- Inter-network resource adjustment and coordination
- Status information of each other

### C. The relationship between Agent and other RAN functions

Naturally, an agent is located at the control plane [6], but that is not to say that it is completely decoupled from the user plane. In fact, there are functions that can be classified as agent functions that benefit from being closely coupled or even integrated with the user plane functionality. Moreover, an important control plane role of RRM and Agent is to handle configuration and reconfiguration of the user plane.

For example, a mapping of Agent to WCDMA system is depicted in Fig. 2, where the agent is isolated from the RRM of RAT, and controls the RRM of RAT by control factor. The function of an agent belongs to the network layer, and is over the RRC protocol in the WCDMA protocol architecture of the Uu implemented interface.

## III. INTERNAL FUNCTIONALITY SPLIT

This section discusses the internal architecture of an agent in detail, including the cognitive layer, reaction layer and

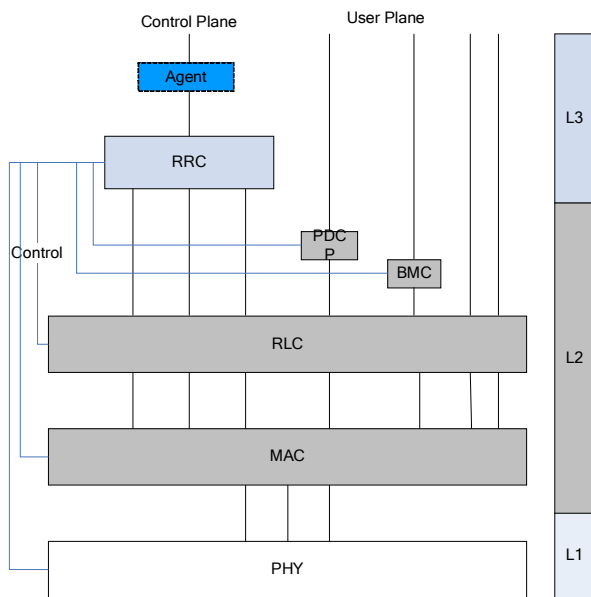

Figure 2. Relations between agent and other RAN functions of

memory layer. In order to better clarify the processing mechanism, some new definitions are also introduced. Fig. 3 depicts the agent internal architecture.

#### A. Cognitive layer

The cognitive layer monitors the controlled radio network and other agents. It can find overlapping cells according to the information either from RAT or from other agents, and can also determine when to perform the adjustment. The cognitive layer comprises the radio cognitive module (RCM) and the cooperation cognitive module (CCM).

RCM collects the status information of the controlled RAT via the Hr interface. RCM perceives automatically whether it is necessary to trigger control or adjustment of the reaction layer. Within RCM, a set of thresholds configured by the reaction layer are defined, e.g. maximum loads, maximum delay, maximum packet loss, etc. Once any of the above statistics exceeds its corresponding threshold, the adjustment is triggered. Alternatively, the agent may execute the adjustment periodically to ensure the operation status is on track.

Besides, RCM also transfers control factors (see Section II-B) and other control information to the control RAT. Some control factors are for the radio network, and others are for the end users. The trigger threshold could be adjusted as per the real situation by the control subsystem. RAT broadcasts adjustable factors and other parameters to mobile terminals, and the network is selected accordingly.

Each agent has its own eigenvector that identifies the agent's features, which is composed of parameters related to resource and control factors. CCM collects the eigenvectors of other agents via the Ha interface and the evaluation results (see Section II-B) of other network. CCM perceives automatically whether it is necessary to trigger control or adjustment of the reaction layer.

#### B. Reaction layer

The control module of the reaction layer is the core control module of the agent and achieves macro-control of the heterogeneous network radio resource. The computation of the control module is triggered by either the change of local RAT or the change of neighbor agents with the overlapping cells. The control module consists of the computation module and the validation module. The functions of the control module are described as follow.

1) *Setting trigger thresholds of cognitive layer:* The thresholds would change with the change of time and are related to the radio transmission environment. These data are stored in the memory layer, and the setting of the trigger thresholds is performed adaptively by the reaction layer.

2) *Managing overlapping cells:* With the information from the cognitive layer, the control module can get the overlapping information with other RATs; then, the control module will store the information in the memory layer and notify the agents of the overlapping cells.

3) *Adjusting radio resource:* The objective function in the control module is used during the adjustment of the radio resource to deal with the coexistence of different RATs. In order to realize the optimization of resource in different radio networks and meet the QoS requirements of different services, the objective function is not only related to the satisfaction degree of the users in the local network, but also related to the satisfaction degree of neighbor-network covering the same area. The objective function is optimized by adjusting the control factors.

4) *Using control factors:* Control factor is a set of variable parameters used to direct each subscribers to select the most suitable RAN in order to adjust the distribution of services. It should contain the following parameters: price and admission control parameters in the network side such as radio network load, mobility capability supported and radio network access conditions. The control factors of the radio network can only be changed by the agent which controls this radio network.

5) *Coordinating with the neighboring agents:* When the adjustment of resource is triggered by other agents, the agent can evaluate whether other agents' behaviors are proper, and then respond with the evaluation result to that agent whose eigenvector parameters have been changed. If the evaluation result is positive, this agent will not be changed. On the contrary, if the evaluation result is negative, this agent will also adjust control factors and the respective eigenvector parameters. After a period of adjustment, the system will achieve a new balance.

6) *Verifying the adjustment results:* In the control module a validation mechanism is used to evaluate whether the adjustment is appropriate. This validation mechanism is based on interactive procedures between different RATs, and is achieved by the validation module.

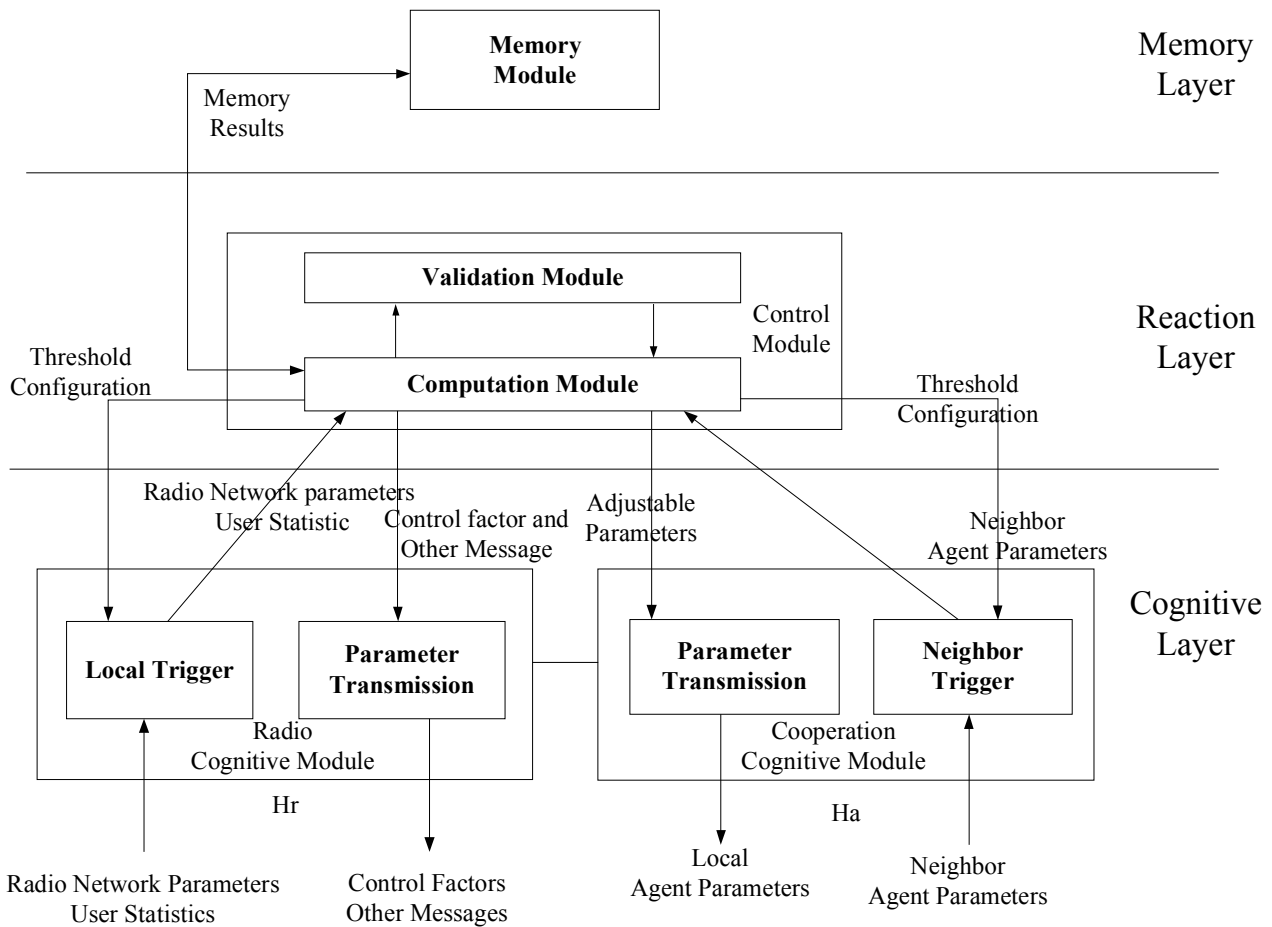

Figure 3. Agent architecture

### C. Memory layer

To accelerate the adjustment and for intelligent control, the memory module is adopted in the memory layer. For each successful adjustment, the memory module should save the results. When the computational module faces a similar situation, the existing suitable adjustment results can be obtained directly from the memory module rather than by recalculation and re-verification. The control subsystem can also get the control policy from the memory layer. Besides, this module has self-learning capabilities, i.e. it can learn from other agents and from itself to enhance efficiency.

## IV. MECHANISM AND PROCEDURES

In order to clearly explain the mechanism of MAS, a work flow of the multi-agent system, which consists of two networks: network A and network B, is depicted as follows (see Fig. 4):

1) Radio cognitive module of network A processes information from the radio network and judges whether it is necessary to send the parameters to the control subsystem or to trigger the control subsystem's adjustment algorithm. It may be a periodic report or a threshold triggered report.

2) After receiving the adjustment trigger request, the control subsystem of network A reads the parameters of network B through the cooperation cognitive module.

3) According to the parameters of the two networks, the control subsystem checks whether adjustment is needed. If so, the control subsystem firstly checks the memory layer to see whether a similar case has appeared. If so, the experience data stored in the memory layer will be exploited by the control subsystem; if not, the adjustment mechanism will be triggered. After the adjustment the results will be checked by the validation module. The control factors change after adjustment.

4) The control subsystem notifies the cooperating cognitive module of network A to send the eigenvector including adjustment parameters to the agent of network B.

5) The cooperating cognitive module of network B triggers the control subsystem of network B after receiving the changed eigenvector of network A.

6) The control subsystem in network B checks whether the adjustment of network A has impact on network B and there are two cases:

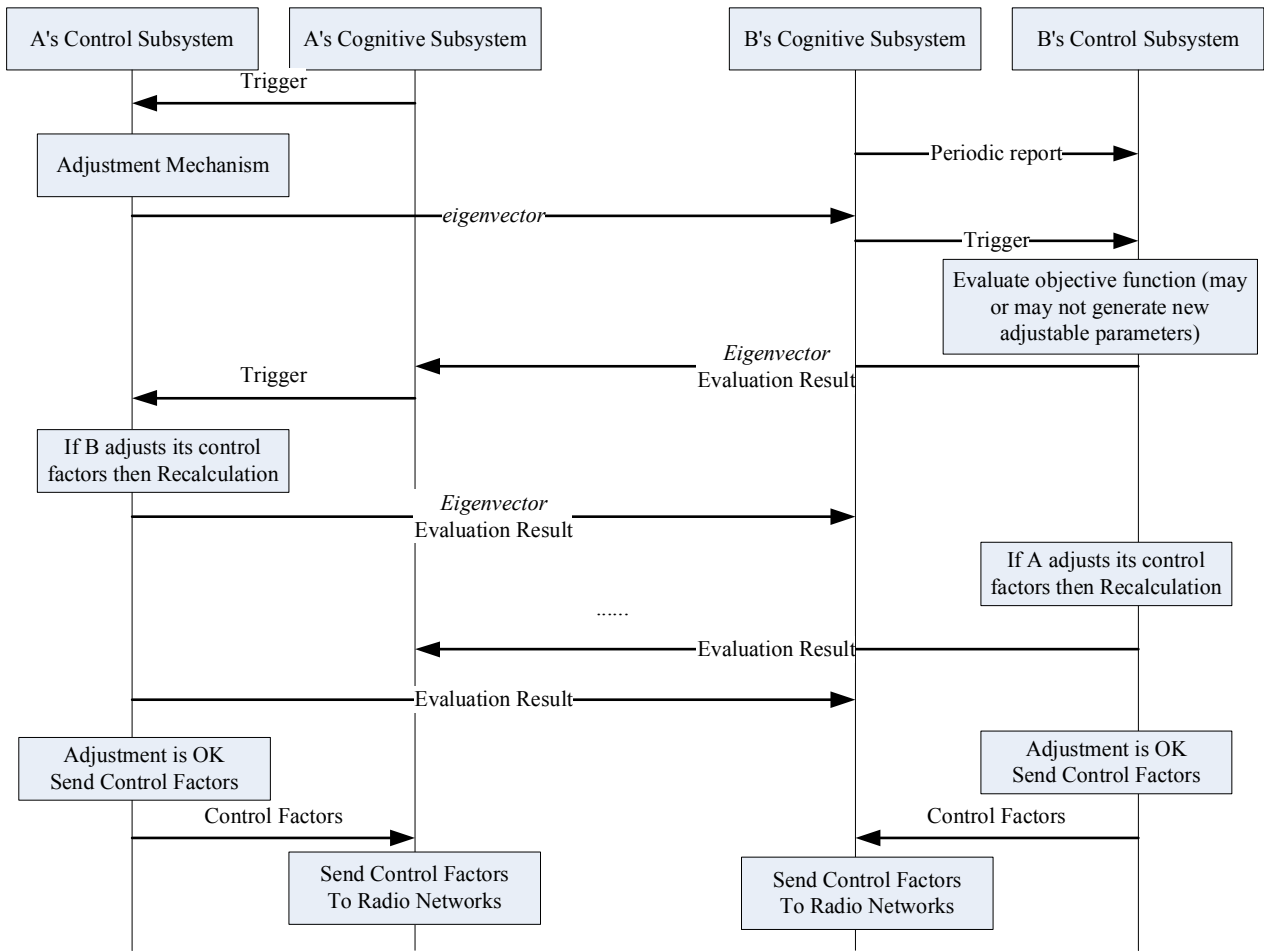

Figure 4. Work flow between two agents

a) Network B will send an affirmative evaluation result to network A to confirm the adjustment result if network B verifies that coexistence is possible through computing the objective function and the evaluation of the validation module;

b) Network B will send a negative evaluation result to network A to deny the adjustment result if system B determines that coexistence is impossible or the value of network B is lost through computing the objective function and the evaluation of the validation module. At the same time network B changes its control factors.

7) Network B sends its evaluation result and its eigenvector to network A.

8) The control subsystem of network A checks the received evaluation result and eigenvector of network B. If the evaluation result is affirmative, the adjustment phase terminates and continues to the next step. If the evaluation result is negative, network A adjusts itself again on the foundation of the adjustment of network B, then goes back to Step 4).

9) The control subsystem of network A and network B both send its control factors to its radio cognitive module

respectively, then send adjustment result and correlative parameters to the memory module.

## V. SUMMARY AND FUTURE WORK

The emergence of B3G will be characterized by the coexistence of different radio technologies, thus requiring advanced radio resource management. The following summarizes the main contribution of our work. Firstly, a novel distributed intelligent Multi-Agent System (MAS), which is a self-organized system to manage the coexistence of multi-RATs operated by different NPs, is presented. Different from existing MRRM, in order to improve the efficiency of radio networks, the multi-agent system performs a macro-control-and-manage function by using control factor and validation mechanism, instead of the micro-control handling detailed RRM decisions concerning individual users. Secondly, the multi-agent system is mainly concerned with the coexistence of different RATs. It considers not only the satisfaction of local network, but also the satisfaction of neighboring network with overlapping cells. In this paper, we also discuss the functions of agent, its working mechanism and specific procedures related to this mechanism.

However, there are still many open issues in the system. One of the difficulties identified is how to make the agent generic and open, and independent of radio networks. Another issue is how to set the trigger threshold and control factors of different radio networks properly. Further, for the radio networks belonging to different NPs, the parameters transferred between radio networks may be limited or different. Besides this, another direction for future research is of testing this multi-agent system in practical networks.

The heterogeneity of the radio networks brings many challenging problems to MRRM. It is natural that our framework has numerous open issues for further study. This article may serve as the trigger point of our series of related research results.

#### REFERENCES

- [1] 3GPP TR 25.881 v5.0.0 "Improvement of RRM across RNS and RNS/BSS (Release 5)" .
- [2] 3GPP TR 25.891 v0.3.0 "Improvement of RRM across RNS and RNS/BSS (Release 6)" .
- [3] J. Luo, R. Mukerjee, M. Dillinger, et al., "Investigation of radio resource scheduling in WLANs coupled with 3G cellular network," *IEEE Communications Magazine*, 41(6): 108–115, 2003.
- [4] J. Luo, E. Mohyeldin, N. Motte and M. Dillinger, "Performance Investigations of ARMH in a Reconfigurable Environment," *SCOUT Workshop*, 16th, Paris, France Sep., 2003.
- [5] J. Luo, E. Mohyeldin, M. Dillinger, P. Demestichas, K. Tsagkaris, G. Dimitrakopoulos, and E. Schulz, "Performance Analysis of Joint Radio Resource Management for Reconfigurable Terminals with Multi-class Circuit-switched Services," *WWRF 12th Meeting*, WG6, Toronto, Canada, Nov., 2004.
- [6] P. Magnusson, J. Lundsjo, J. Sachs, and P. Wallentin, "Radio resource management distribution in a beyond 3G multi-radio access architecture," *Global Telecommunications Conference, IEEE* , 29 Nov.-3 Dec. 2004 Page(s):3472 - 3477 Vol. 6.
- [7] P. Demestichas, V. Stavroulaki, L. Papadopoulou, A. Vasilakos and M. Theologou, "Service configuration and distribution in composite radio environments," *IEEE Transactions on Systems, Man and Cybernetics*, 2003, 33(4): 69-81.
- [8] P. Demestichas and V. Stavroulaki, "Issues in introducing resource brokerage functionality in B3G, composite radio, environments," *IEEE Wireless Communications*, 2004 11(5): 32-40.