



Title	LED wireless
Author(s)	Pang, G; Kwan, T; Liu, H; Chan, CH
Citation	IEEE Industry Applications Magazine, 2002, v. 8 n. 1, p. 21-28
Issued Date	2002
URL	http://hdl.handle.net/10722/44859
Rights	©2002 IEEE. Personal use of this material is permitted. However, permission to reprint/republish this material for advertising or promotional purposes or for creating new collective works for resale or redistribution to servers or lists, or to reuse any copyrighted component of this work in other works must be obtained from the IEEE.

LED WIRELESS

A novel use of LEDs to transmit audio and digital signals

BY GRANTHAM PANG, THOMAS KWAN, HUGH LIU, & CHI-HO CHAN

THE SUPERIORITY OF LIGHT-EMITTING diodes (LEDs) over incandescent lights, due to long life expectancy, high tolerance to humidity, low power consumption, and minimal heat generation, is well supported. LEDs are used in message display boards, signal devices, and many other means of illumination. One important characteristic of LEDs is that they are semiconductor devices capable of fast switching with the addition of appropriate electronics. That is, the visible light emitted by LEDs can be modulated and encoded with audio information for broadcasting. Therefore, in addition to their normal functions as indication and illumination devices, LEDs can be used as communication devices for transmitting and broadcasting audio and digital information. Hence, they can become part of wireless optical-communication systems. This article describes an information system for the broadcasting of audio and digital signals using visible LEDs.

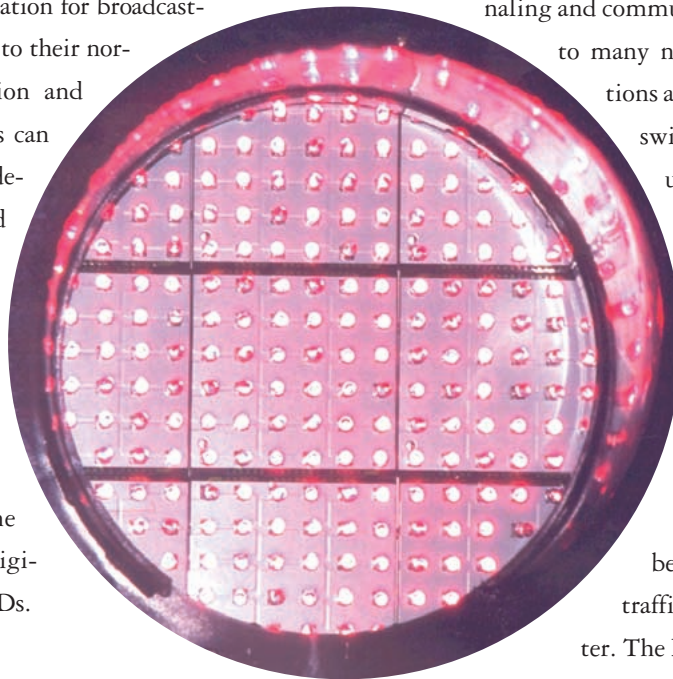

Background

Billions of visible LEDs are produced each year, and the emergence of high-brightness AlGaAs and AlInGaP devices has given rise to many new markets [1]-[3]. The surprising growth of activity in, relatively old, LED technology has been spurred by the introduction of AlInGaP devices. Recently developed AlGaInN materials

have led to improvements in the performance of bluish-green LEDs [1]. The entire visible spectrum is occupied with these LEDs, which have luminous efficacy peaks much higher than those for incandescent lamps [3], [4]. This advancement has led to the production of large-area full-color outdoor LED displays with diverse industrial applications.

The novel idea of this article is to modulate light waves from visible LEDs for communication purposes [5]-[8]. This concurrent use of visible LEDs for simultaneous signaling and communication, called *iLight*, leads

to many new and interesting applications and is based on the idea of fast switching of LEDs and the modulation of the visible-light waves for free-space communications. The feasibility of such an approach has been examined and hardware has been implemented with experimental results. The implementation of an optical link has been carried out using an LED traffic-signal head as a transmitter. The LED traffic light (Fig. 1) can

be used for either audio or data transmission. Audio messages can be sent using the LED transmitter, and a receiver located at a distance around 20 m away can play back the messages with a speaker. Another prototype that resembles a circular speed-limit sign with a 2-ft diameter (Fig. 2) was built. The audio signal can be received in open air over a distance of 59.3 m or 194.5 ft. For

data transmission, digital data can be sent using the same LED transmitter, and experiments were set up to send a speed limit or location ID information.

The work reported in this article differs from the use of infrared (IR) radiation as a medium for short-range wireless communications [9], [10]. Currently, IR links and local-area networks are available. IR transceivers for use as IR data links are widely available in the market. Some systems are comprised of IR transmitters that convey speech messages to small receivers carried by persons with severe visual impairments. The Talking Signs system is one such IR remote signage system developed at the Smith-Kettlewell Rehabilitation Engineering Research Center [11], [12]. It can provide a repeating, directionally selective voice message that originates at a sign. Comparison between IR and other media, such as radio and microwave, is given in [13]. However, there has been very little work on the use of visible light as a communication medium.

The availability of high-brightness LEDs makes the visible-light medium even more feasible for communications. All products with visible-LED components (like a LED traffic signal head) can be turned into an information beacon. This iLight technology has many characteristics that are different from IR. The iLight transceivers make use of the direct line-of-sight (LOS) property of visible light, which is ideal in applications for providing directional guidance to persons with visual impairments. On the other hand, IR has the property of bouncing back and forth in a confined environment. Another advantage of iLight is that the transmitter provides easy targets for LOS reception by the receiver. This is because the LEDs, being on at all times, are also indicators of the locations of the transmitter. A user searching for information has only to look for lights from an iLight transmitter. Very often, the device is concurrently used for illumination, display, or visual signage. Hence, there is no need to implement an additional transmitter for information broadcasting. Compared with an IR transmitter, an iLight transmitter has to be concerned with even brightness. There

should be no apparent difference to a user on the visible light that emits from an iLight device.

It has long been realized that visible light has the potential to be modulated and used as a communication channel with entropy. The application has to make use of the directional nature of the communication medium because the receiver requires a LOS to the audio system or transmitter. The locations of the audio signal broadcasting system and the receiver are relatively stationary. Since the relative speed between the receiver and the source are much less than the speed of light, the Doppler frequency shift observed by the receiver can be safely neglected. The transmitter can broadcast with a viewing angle close to 180° . This article aims to present an application of high-brightness visible LEDs for establishing optical free-space links.

System Description

A block diagram representation of the schematic diagram of the transmitter design is shown in Fig. 3, and a developed prototype is shown in Fig. 4. The audio signal from a cassette tape or CD player has small amplitude, hence, amplification of this audio signal is necessary. The audio amplifier is used to amplify the weak audio signal and shift the average voltage level of the audio signal to an appropriate level so that the signal is within the capture range of a voltage-controlled oscillator (VCO). A VCO chip is used to modulate the incoming audio signal variations from the audio amplifier and generate the FM signal. A square wave VCO is used instead of sine

wave because there are only two states (on and off) for the LEDs. The carrier frequency is set at 100 kHz with a maximum frequency deviation of ± 50 kHz. The modulated signal is transmitted by the switching of the LEDs. The frequency of switching is high enough that the perceivable light appears to be constantly illuminated to the human eye.

A block diagram schematic and a prototype of the audio receiver are shown in Figs. 5 and 6, respectively. The photo-detector is used to detect a light signal from the transmitter and convert it into an electrical signal. The limiting pre-amplifier is used to amplify the electri-

HIGH-BRIGHTNESS
LEDS ARE
GETTING MORE
POPULAR AND
ARE OPENING
UP A NUMBER
OF NEW
APPLICATIONS.



Photograph of a LED traffic light.



Circular sign.

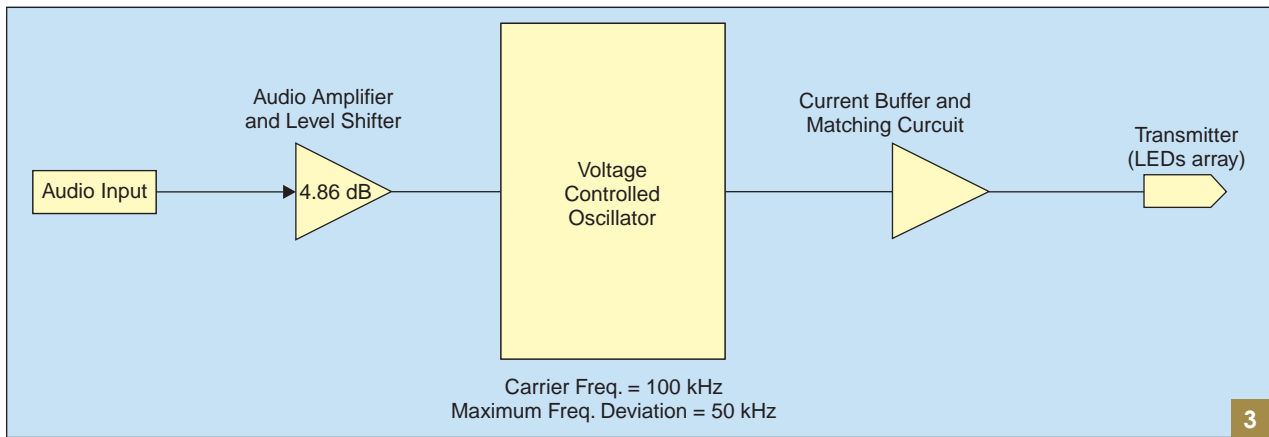

Block diagram representation of the schematic diagram of the transmitter design.

cal signal from the photo-detector for the next stage. The data-reproducing circuit is used to reconstruct the square wave. The differentiator circuit is used to produce pulses according to the square wave. The pulse generator is used to convert the pulses from the differentiator into sharp pulses for use by the integrator and envelope detector in the next stage for the demodulation of the signal. The band-pass filter is then used to smooth out the distortions from the integrator and envelope detector to produce an appropriate waveform. Finally, the power amplifier is used to amplify the weak signal from the band-pass filter so that the audio signal would be comfortable for hearing. Below is a more detailed description of each stage.

Photo-Detector Circuit

The photo-detector circuit consists of a photodiode and a resistor. One end of the photodiode is coupled to the current limiting resistor with the other end coupled to ground. Since the signal from the photo-detector circuit is small, amplification is needed for the next stage. The limiting pre-amplifier circuit consists of two op-amplifiers as well as some resistors and diodes. The diodes are used to limit the input voltage level to a desired level (such as between -0.7 and 0.7 V). This circuit aims to amplify the input signal to a certain level, and a comparator is used to produce rectangular signal pulses. Two pre-amplifiers are used in this circuit because using one pre-amplifier will require a very high gain amplifier. Hence, two pre-amplifi-

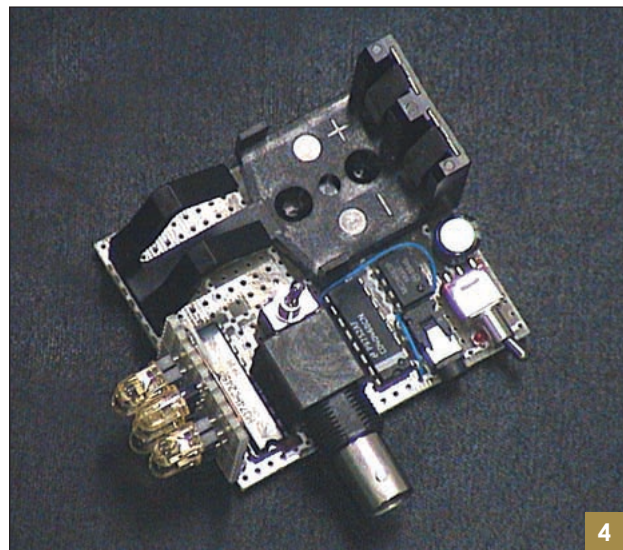

Prototype of an audio transmitter.

ers, each with lower gain, are used to achieve a high gain with reduced noise.

Data-Reproducing Circuit

Next, a data-reproducing circuit, which consists of an operational amplifier, a resistor, and two NAND Schmitt

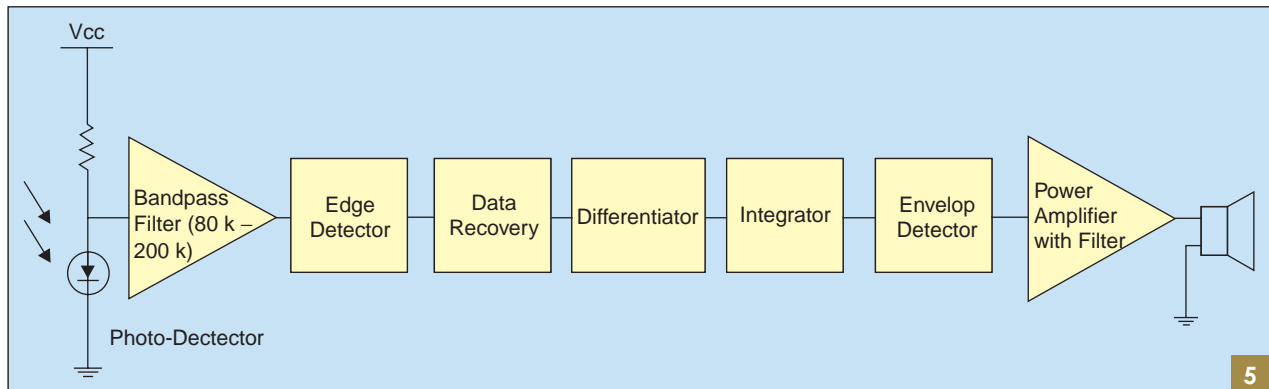

Block diagram representation of the schematic diagram of the audio receiver design.

TABLE 1. LED TRAFFIC SIGNAL HEAD SPECIFICATIONS

Signal color	Red
Construction	441 red ultra-bright LEDs with a luminous intensity of 2000 mcd @20 mA
Diameter	8 in
Nominal usage	17 V; 2 A
Nominal power consumption	34 W
Luminous intensity	300 cd
Viewing angle $2\alpha_{1/2}$ (half power)	30°
Distance for audio transmission (outdoors)	Over 20 m

triggers, is used. Its function is to produce rectangular pulses from the amplified signal in the previous stage. An operational amplifier is used as a comparator which uses virtual ground as a reference. The NAND Schmitt trigger gates are used to enhance the noise immunity and to correct

LEDs can be used as communication devices for transmitting and broadcasting information.

edges from low to high voltage levels due to the slow rate of the amplifier. Two NAND Schmitt trigger gates are used instead of one so that the signal will not be inverted. Then, a differentiator circuit consisting of a capacitor and a resistor is used to detect the leading edges of the pulse with the trailing edges blocked by a diode. Next, there is the circuit of a pulse generator. A Schmitt trigger gate is used as a pulse

generator, and the output gives the inverted version of pulses from the differentiator.

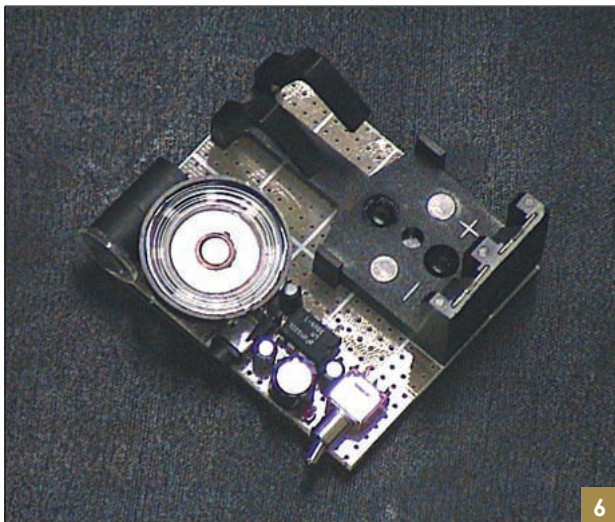

6
 Prototype of an audio receiver.

Integrator and Envelope Detector

An integrator and envelope detector can be found next. The integrator is an envelope detector, and double integrations are carried out. If the inverted pulses from the pulse generator contain high frequency, the frequency of integration is higher and the voltage level of the output would be higher. However, if the inverted pulses contain low frequency, the frequency of integration is lower and the voltage level of the output would be lower. In this way, the modulated signal would be reconstructed.

Band-Pass Filter

Next, a band-pass filter is used. The output signal from the previous stage, integrator and envelope detector, has many distortions. A band-pass filter is used to filter out all the high-frequency distortions. The higher cut-off frequency depends on a capacitor and resistor. A lower cutoff is also used to filter out the low-frequency noise, such as the 50-Hz power line frequency. The output signal from the band-pass filter is an audio signal.

Power Amplifier

The final stage of the receiver circuit is a power amplifier, the output of which is connected to the speaker. The objective is for the delivery of the audible messages through a speaker or headphone/ear jack.

Applications of the Visible-LED system

High-brightness LEDs are increasingly being used in traffic lights due to their low power consumption and minimal required maintenance, which can be translated into considerable cost savings each year [14]. For example, Philadelphia, Pennsylvania, USA, is replacing all of its 28,000 red signals with LEDs, with an estimated annual cost savings of \$1.2 million. The next stage of development will involve the three-color LED signals. In Singapore, there has been a complete change of traffic signals from incandescent to LED [15]. The \$12.7 million project has replaced all 60,000 incandescent lamps in 1,600 intersections of the city. Again, power and maintenance savings, as well as safety, are cited as the reasons for the replacement. An LED traffic signal can use only 18 ultra-bright LEDs and is warranted for five years. LED power consumption is only 8-12 W, compared with around 150 W used by its incandescent counterpart [16].

With the ideas and developments described in this article, an LED traffic light can be used as an audio broadcasting device, in addition to their normal function of being an indication and signaling device. A receiver some distance away pointing at the traffic light can receive voice messages. For drivers, the message can announce the time until the next signal change. For pedestrians or people with visual impairments, the voice message can tell location or directional information.

The above development allows a concurrent use of traffic lights because it can broadcast local traffic information, location and road information to both pedestrians and road users, and simultaneously perform its normal function of being a traffic-signaling device. The LED traffic light, called Intelligent Traffic Light, becomes a new kind of

short-range information beacon. Essentially, all LED-based traffic signs, displays, or illumination devices can perform the above functions.

Other applications can be found in a museum or exhibit-hall environment. The information on an individual exhibit can be broadcast via a plurality of LEDs, which is also used for the purpose of illumination. With the guest pointing the receiver to the relevant LEDs on a transmitter, with the headphone or ear jack attached to the portable receiver, he can listen to the audio message about the specific exhibit item he is interested. Thus, the indoor environment can remain quiet while the guests stroll in the museum. This is a major advantage over conventional broadcasting systems in that individuals with receivers have the freedom of choice to receive specific messages without hearing any unwanted announcement, music, or commercials.

Implementation and Experimental Results

An LED traffic-signal head made up of 441 high-brightness LEDs (Fig. 3) has been implemented in the Industrial Automation Research Laboratory at The University of Hong Kong (<http://ial.eee.hku.hk>). Each LED is a Hewlett Packard high intensity AlInGaP type with a luminous intensity of 2000 mcd at 20-mA rated driving current, and the viewing angle is 30°. The specifications of the LED traffic-signal head is given in Table 1.

The radiation pattern of the LED traffic light is given in Fig. 7. An HP Audio Analyzer, which has a low-distortion signal source with a signal analyzer, is then used for audio measurement of the visible-light LED audio broadcasting panel. The frequency response of the communication channel occupied by the audio signal was determined. Here, the frequency of the audio signal transmitted via the LEDs was varied, and the response was observed using the HP audio analyzer. The frequency response is not as flat as may be expected from the enormous bandwidth of visible light. This is due to the limitations inherently governed by the VCO in the transmitter and the discriminator used at the receiver. The frequency-response characteristic of the system is shown in Fig. 8. In another measurement on the signal-to-noise ratio (SNR), the result is shown in Fig. 9.

The same Intelligent Traffic Light has also been used for data transmission. Digital data can be sent using the same LED transmitter, and experiments have been set up to send

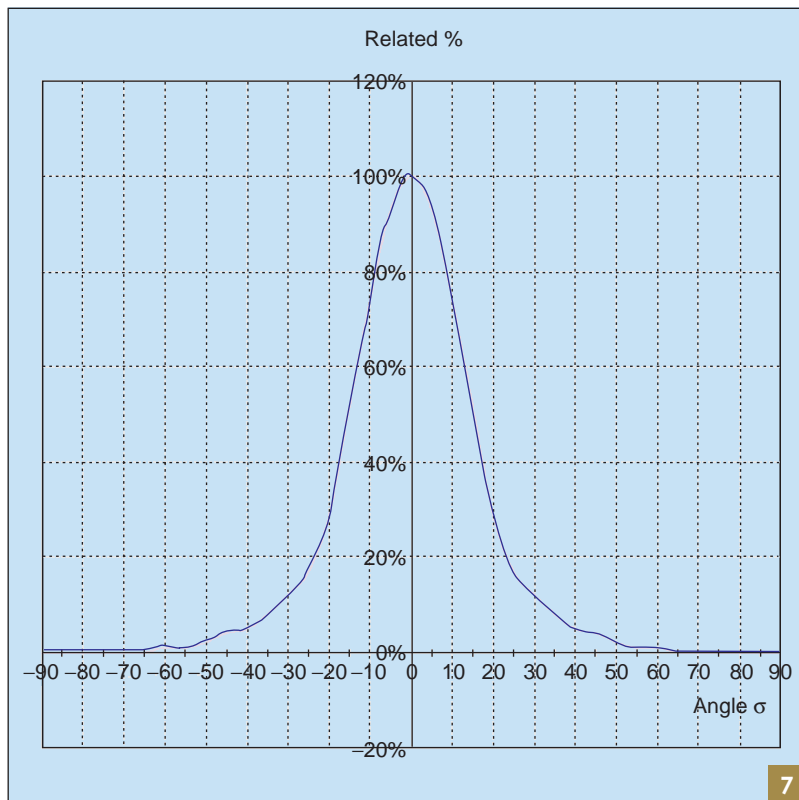

Radiation pattern of the LED traffic light.

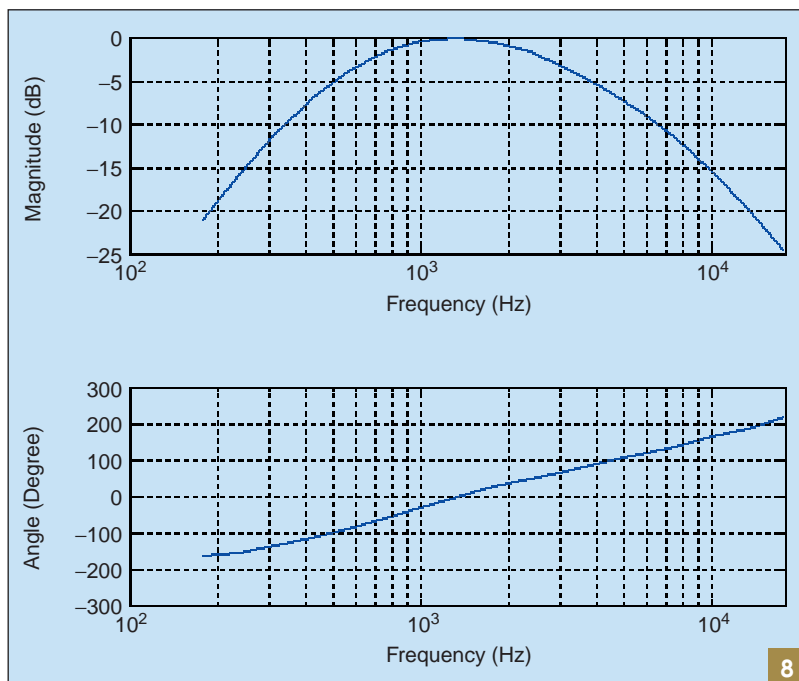

Frequency-response characteristics of the system.

digital information. A receiver, which resembles a portable traveler location system, has been implemented to obtain the demodulated signal. The block diagram of the receiver is shown in Fig. 10.

TABLE 2. BER EXPERIMENT RESULTS

Power of visible-light signal at the receiver	BER
0.5 μ W	2.1315×10^{-3}
0.6 μ W	5.2177×10^{-7}
0.7 μ W	2.4835×10^{-7}
0.8 μ W	9.1982×10^{-8}
1.8 μ W	$< 2.2155 \times 10^{-10}$

A bit error rate (BER) experiment for the LED traffic light has been performed (Fig. 11). In the experiment, frames of data were transmitted continuously from a computer to the serial communication interface circuit via the printer port of the computer. The modulated signal is transmitted by the LED traffic light. The visible-light signal was transmitted to the receiver, and the serial-communication interface performs demodulation of the data. The computer at the receiver side would compare the received

data with the transmitted data. The number of error bits would be recorded.

The data frames transmitted by the LED traffic light contained a pseudo-random series of data divided into 31 data blocks. The transmission speed of the visible-light communication channel is 128 kbps. The indoor ambient-light power was measured by an optical power meter and found to be 12 μ W. Table 2 shows the results of the BER test.

It is observed that the BER decreases as the power (or luminance) transmitted by the LED traffic light increases. In other words, the brighter the traffic light, the smaller is the BER. It has been found by another experiment that BER increases with the separation between the traffic light and the receiver. A graph of $\log(\text{BER})$ plotted against $\log(\text{separation})$ is approximately linear. On light intensity L received by the receiver, there is an approximate linear relationship between $\log(L)$ and $\log(\text{separation})$. The two above imply a linear relationship between $\log(\text{BER})$ and $\log(L)$.

In a real situation, there will be other visible-light sources nearby. One example would be the headlight of a vehicle traveling in the opposite lane. Thus, the effect of a headlight was evaluated. This situation was simulated by placing a lamp with a 100-W light bulb beside the LED traffic light. The BERs for the traffic light signal at 0.7 μ W were compared. Without the headlight, the BER is 2.4835×10^{-7} . With the headlight, the BER is 1.1232×10^{-6} . This shows that light source interference would increase the BER.

The laboratory has also developed a number of prototypes to demonstrate the feasibility of the iLight technology. Figs. 12-14 show the different types of displays and the receivers that have been developed.

Conclusions

High-brightness LEDs are getting more popular and are opening up a number of new applications, especially with improved efficiency and new colors.

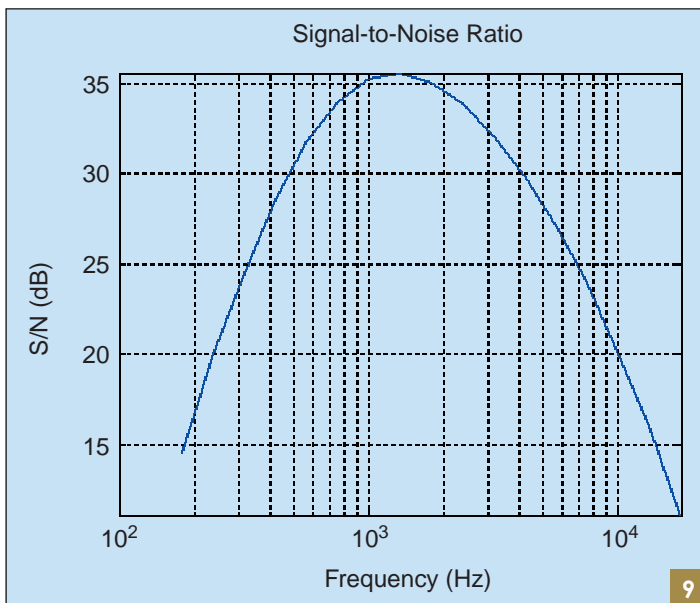

Measurement on the SNR.

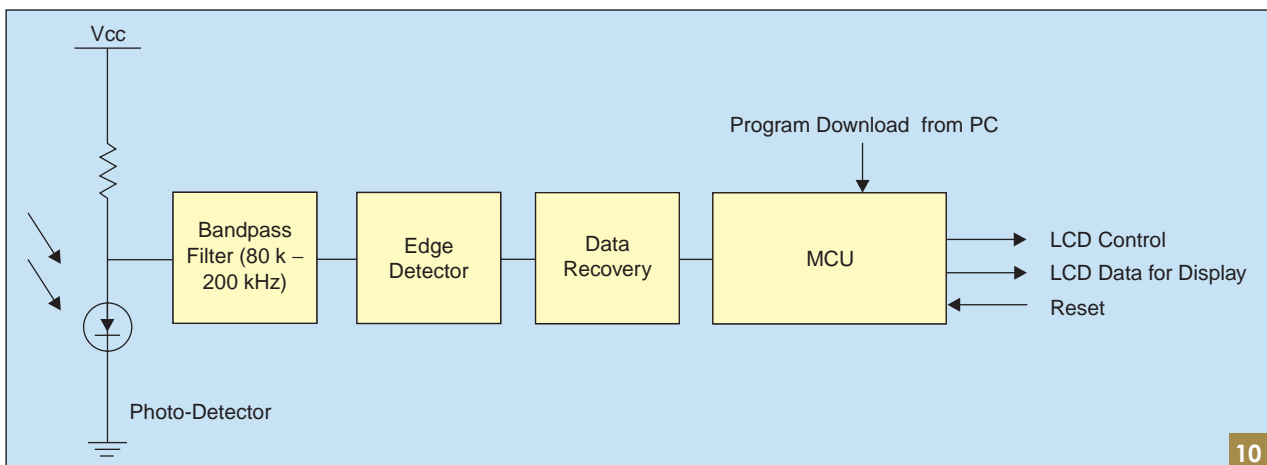

An iLight digital receiver.

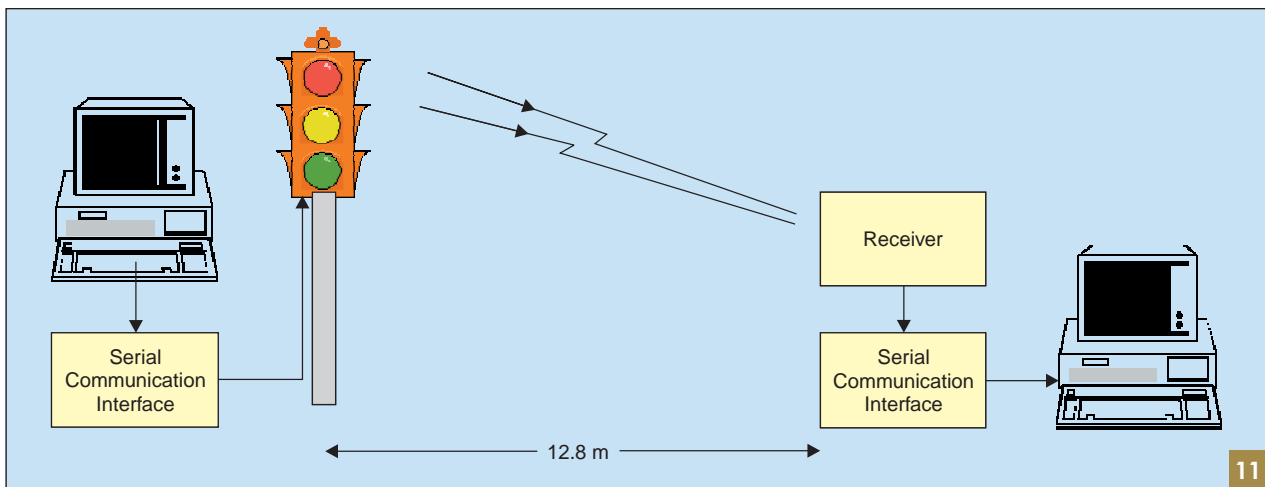

BER experimental setup.

In this article, the novel idea based on the fast switching of LEDs and the modulation of visible light is developed into a new kind of information system. A visible-LED audio system that makes use of visual-light rays to transmit audio messages to a remotely located receiver is described. Such a system made up of high-brightness visible LEDs can provide the function of open space, wireless broadcasting of audio signals. It can be used as an information beacon for short-distance communication.

As a medium for wireless short-range communication, visible light has both advantages and disadvantages when compared with IR, microwave, and radio media. On one hand, LEDs and photodetectors capable of high-speed operation are available at low cost. Like the IR, the visible spectral region is unregulated worldwide and FCC licenses are not necessary, as the commission does not regulate the visible-light frequencies. Both IR and visible light penetrate through glass, but not through walls. For transmission to be possible, there must be no obstructions standing in the way of the visible-LED light beam as it requires a clear LOS between the sending side (LED) and receiving side, whereas IR also allows nondirected and non-LOS link design. Like microwaves, visible-LED light beams follow a straight-line path and are well suited for the wireless delivery of large quantities of voice and data information. In practical use, one should take advantage of this highly directional feature of LEDs.

On the other hand, LEDs also have many drawbacks. They are suitable for short range only, as the photodetector current is proportional to the received power. Intensity modulation with direct detection seems the only practical transmission method. The SNR of a direct-detection receiver is proportional to the square of the received optical power. It should also be mentioned that the relationship be-



Headphone receiver of audio signal.

tween the radiant intensity and distance from the receiver follows the inverse square law. Hence, as a communication medium, it has limited range and is subject to noise arising from sunlight, incandescent lighting, and fluorescent lighting. It is not suitable for broadcasting signals over a wide coverage area or over long ranges.

Any illumination device making use of high-brightness visible LEDs can be used as a kind of short-range information beacon. Many interesting examples are given in this article. One example is an LED traffic light for the support of roadside-to-vehicle communications. There are many potential novel uses of visible light from LEDs as a communication medium. This concurrent use of LEDs for simultaneous signaling and communications will open up many new applications.

THE CONCURRENT
USE OF LEDs FOR
SIMULTANEOUS
SIGNaling AND
COMMUNICATIONS
WILL OPEN UP
MANY NEW
APPLICATIONS.

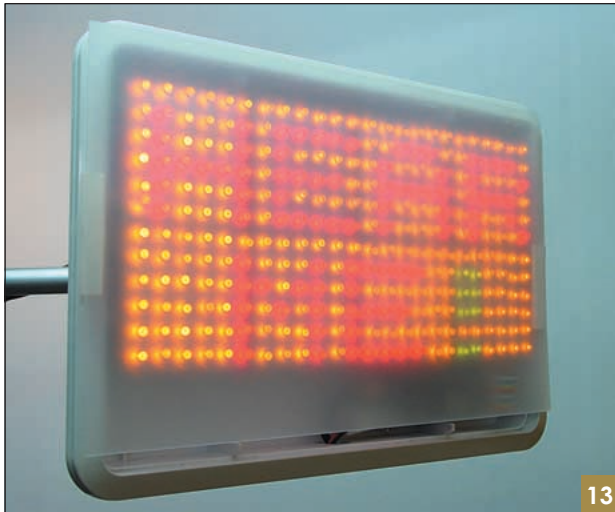

13

LED display as an iLight audio transmitter.

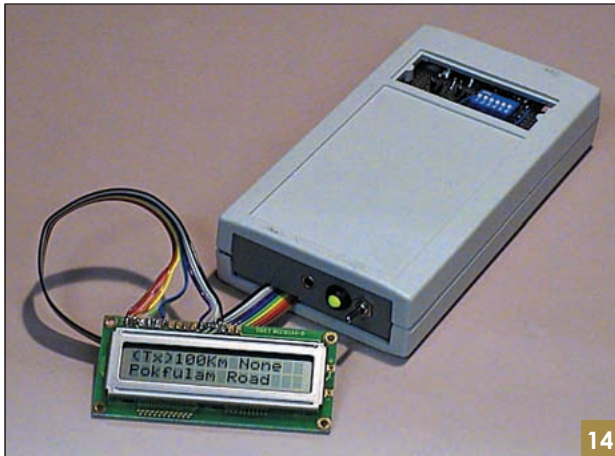

14

Prototype of digital receiver.

Acknowledgements

The authors would like to thank Professor E.S. Yang for sharing the idea of using LEDs for communications, and The University of Hong Kong for financial support of this work

References

- [1] G.B. Stringfellow and M.G. Craford, *Semiconductors and Semimetals*, vol. 48, *High Brightness Light Emitting Diodes*. New York: Academic, 1997.

- [2] M.G. Craford, "LEDs challenge the incandescents," *IEEE Circuits Devices Mag.*, vol. 8, pp. 24-29, Sept. 1992.
- [3] K. Werner, "Higher visibility for LEDs," *IEEE Spectr.*, vol. 31, pp.30-39, July 1994.
- [4] P.P. Smyth, P.L. Eardley, K.T. Dalton, D.R. Wisley, P. McKee, and D. Wood, "Optical wireless—A prognosis," in *SPIE Proc. Wireless Data Transmission*, 1995, vol. 2601, pp. 212-225.
- [5] G. Pang, C.H. Chan, and T. Kwan, "Tricolor light emitting diode dot matrix display system with audio output," *IEEE Trans. Ind. Applicat.*, vol. 37, pp. 534-540, Mar./Apr. 2001.
- [6] G. Pang, T. Kwan, C.H. Chan, and H. Liu, LED traffic light as communication device, in *Proc. IEEE/IEEJ/JSAI Int. Conf. Intelligent Transport Syst.*, Tokyo, Japan, 1999, pp. 788-793
- [7] G. Pang, H. Liu, C.H. Chan, and T. Kwan. (1998). "Vehicle location and navigation systems based on LEDs," in 5th World Congr. Intelligent Transport Syst. [CD-ROM]. Paper 3036.
- [8] G. Pang, C.H. Chan, H. Liu, and T. Kwan. (1998). "Dual use of LEDs: Signalling and communications in ITS," in 5th World Congr. Intelligent Transport Syst. [CD-ROM]. Paper 3035.
- [9] T.S. Chu and M.J. Gans, "High speed infrared local wireless communication," *IEEE Commun. Mag.*, vol. 35, pp. 4-10, Aug. 1997.
- [10] M. Meyer, "Infrared LEDs," *Compound Semicond.*, pp. 39-40, May/June 1996.
- [11] W. Loughborough, "Talking signs—An accessibility solution for the blind and visually impaired," presented at the 12th CMBEC/1st Pan-Pacific Symp., Vancouver, Canada, 1986.
- [12] B.L. Bentzen and P.A. Mitchell. (1995). "Audible signage as a wayfinding aid: Comparison of 'verbal landmarks' and 'talking signs'." [Web site] California Council of the Blind and Assn. for the Advancement of the Blind, Berlin, MA. Available: <http://www.ski.org/Rehab/WCrandall/General/ACBPAPER.HTM>
- [13] J.M. Kahn and J.R. Barry, "Wireless infrared communications," *Proc. IEEE*, vol. 85, pp.265-298, Feb. 1997.
- [14] J. O'Connell, "The Philadelphia story," *Traffic Technology Int.*, pp. 106-110, Aug./Sept. 1997.
- [15] "Stop-Go in Singapore," *ITS Int.*, p. 47, July/Aug. 2000.
- [16] N. Behura, "LED traffic signals—Why not now?," *ITS Int.*, pp. 39-40, July/Aug. 2000.

Grantham Pang (gpang@eee.hku.hk), Thomas Kwan, Hugh Liu, and Chi-Ho Chan are with The University of Hong Kong. This article first appeared in its original form at the 1999 IEEE IAS Annual Meeting.