



Title	Grouted jetted precast concrete sheet piles: Method, experiments, and applications
Author(s)	Xu, GH; Yue, ZQ; Liu, DF; He, FR
Citation	Canadian Geotechnical Journal, 2006, v. 43 n. 12, p. 1358-1373
Issued Date	2006
URL	http://hdl.handle.net/10722/44620
Rights	Creative Commons: Attribution 3.0 Hong Kong License

Grouted jetted precast concrete sheet piles: Method, experiments, and applications

G.H. Xu, Z.Q. Yue, D.F. Liu, and F.R. He

Abstract: This paper introduces an innovative technology—grouted jetted precast concrete piling—that increases the efficiency of piling operations in coastal regions. The technology includes the following steps: (i) casting concrete piles factory-designed especially for jetting and grouting; (ii) jetting to drive the concrete piles with a crane on a floating ship or platform into soil; and (iii) grouting to enhance the sheet pile connections and to increase the pile bearing capacity. This technology was applied to a number of piling construction projects at the mouth of the Yellow River Delta in China, and this experience demonstrated that it is a robust, fast track, cost-effective, and environmentally friendly piling method.

Key words: piling technique, sheet pile, jetting, retaining walls, coastal infrastructure, Yellow River.

Résumé : Cet article introduit une technologie innovatrice, soit des pieux préfabriqués en béton foncés par jet et injectés, qui augmente l'efficacité des opérations de mise en place de pieux dans les régions côtières. La technologie comprend les étapes suivantes : (i) mouler des pieux de béton conçus spécialement en manufacture pour la mise en place par jet et injection; (ii) mise en place par jet pour fonder les pieux de béton avec une grue sur un chaland flottant ou une plate-forme sur le sol; et (iii) injecter pour augmenter le lien entre les pieux palplanches et pour accroître la capacité portante du pieu. Elle a été mise en application sur un certain nombre de projets de construction de pieux à l'embouchure du Delta de la Rivière Jaune en Chine, et cette expérience a démontré qu'elle est une méthode de construction de pieux robuste, rapide, économique et qui respecte l'environnement.

Mots clés : technique de construction de pieu, palplanche, murs de soutènement, infrastructure côtière, Rivière Jaune.

[Traduit par la Rédaction]

Introduction

It has long been recognized that the use of water jetting is a very effective method of driving piles into soil, particularly firm clay, sands, or loose gravel (Shestopal 1959; Tsinker 1977). Jetting can be used for driving concrete or heavy timber piles and sheet piles including wide flange, T-shaped, or similar concrete sheet piles. It is a relatively quiet driving process because it does not shake the ground, and it can also help to minimize damage to piles in hard clay or dense sand. It should be particularly suitable for construction work in coastal regions, where water is plentiful for jetting. Seawater can be used for jetting, and its use has no noticeable effect on the natural environment.

In the 1980s U.S. Navy civil engineers developed a pre-fabricated footing with an internal water-jetting system. It was used to install steel piles in all types of sea floors. It ac-

commodated pile placement in clay, silt, sand, gravel, and even rock or coral. The jetting system enabled the footing to drive through the seabed until it was buried by its own weight (Tsinker 1988).

Conventional jetting methods have not been widely used in pile installation for coastal marine structures around the world. It has been suggested that the soil adjacent to a jetted pile is disturbed by jetting and that the soil later undergoes consolidation as the excess pore pressure dissipates. As a result, the structure and properties of the surrounding soil are significantly changed (Hameed et al. 2000). The soil adjacent to a jetted pile becomes a disturbed zone with unknown properties and characteristics, reducing pile bearing capacity.

To increase pile bearing capacity, jetting is not allowed for the final impact driving. Instead, conventional impact driving techniques are used for the final setting of jetted piles (Tsinker 1988; Hameed et al. 2000). Other techniques have also been used. For example, filling boulders, cobbles, and coarse gravels into the loose zone between the pile and the surrounding soil has been used to increase the pile bearing capacity (Tsinker 1988).

These two methods for increasing the bearing capacity of jetted piles are costly and time consuming. It is also difficult to predict the pile bearing capacity of jetted piles and to achieve satisfactory control over the filling of large hard materials in the loose zone. Impact-driven piles are reported to have better load-bearing features than jetted-driven piles under comparable soil conditions (Tsinker

Received 13 December 2004. Accepted 22 August 2006.
Published on the NRC Research Press Web site at
<http://cgj.nrc.ca> on 19 January 2007.

G.H. Xu and D.F. Liu. School of Environment and Construction, Ocean University of China, Qingdao, P.R. China.

Z.Q. Yue.¹ Department of Civil Engineering, The University of Hong Kong, Pokfulam Road, Hong Kong, P.R. China.

F.R. He. Petroleum Management Bureau, Consultative Committee of Shengli, Dongying, P.R. China.

¹Corresponding author (e-mail: yueqzq@hkucc.hku.hk).

1988), though they may cause failures in soft soils (Li et al. 2005a, 2005b).

In this paper, we present an innovative piling method, which we call the grouted jetted precast sheet piling method, to resolve the bearing capacity issue associated with conventional pile jetting in coastal regions. We have developed a new jetting technique that retains the main advantage of the traditional jetting technique—its quietness—while minimizing disturbance to the soil around the pile. Furthermore, we developed a grouting technique to firmly connect adjacent sheet piles and to improve the shear strength of the disturbed soil zone adjacent to the jetted pile. This paper provides a detailed description of this new piling method and discusses a number of experiments to assess its effectiveness. It also provides examples of its recent application in a number of civil infrastructural projects on the coast of northern China, near the mouth of the Yellow River.

Grouted jetted precast concrete sheet piling method

General

The conventional jetting technique uses a straight jetting pipe with a single nozzle at its tip to disturb and weaken the ground and to lead the pile into the weakened ground by gravity (Fig. 1). The water jet spreads into the soil in the form of a cone (Fig. 2a). This jetting method disturbs and weakens the soil around the pile, resulting in lower pile bearing capacity.

In the new jetting technique, the jetting pipe is incorporated within the pile (Fig. 2a) or the sheet pile (Fig. 2b), and instead of a single nozzle (Figs. 1 and 2a) a large number of smaller nozzles (Fig. 2b) are used for jetting water. The water is jetted from the small holes at the pile toe in the form of a uniform rectangular column. As a result, the soil beneath and adjacent to the sheet pile toe can be vertically cut. The disturbed gap between the sheet pile and the undisturbed soil is relatively small, typically 10–20 mm wide.

Set up

The new grouted jetted piling method consists of a floating platform with a crane to lift the piles and two pump systems (Fig. 3). The pile sinks vertically into water and soil at the chosen position by its own weight. One of the two pump systems is for jetting water and the other is for grouting. The sheet pile has a central pipe for jetting.

Concrete sheet pile special features

Besides the normal reinforcement, the precast concrete sheet pile design includes several nonstandard items.

Central pipe

The sheet pile has a steel pipe along its central axis (Fig. 4). The pipe is open at the pile head for connection with a plastic hose and transfers pressured water from the hose to the pile toe.

Fig. 1. Conventional jetting of water in the form of a cone from one nozzle at the toe of a jet pipe adjacent to a pile (modified from Tsinker 1988).

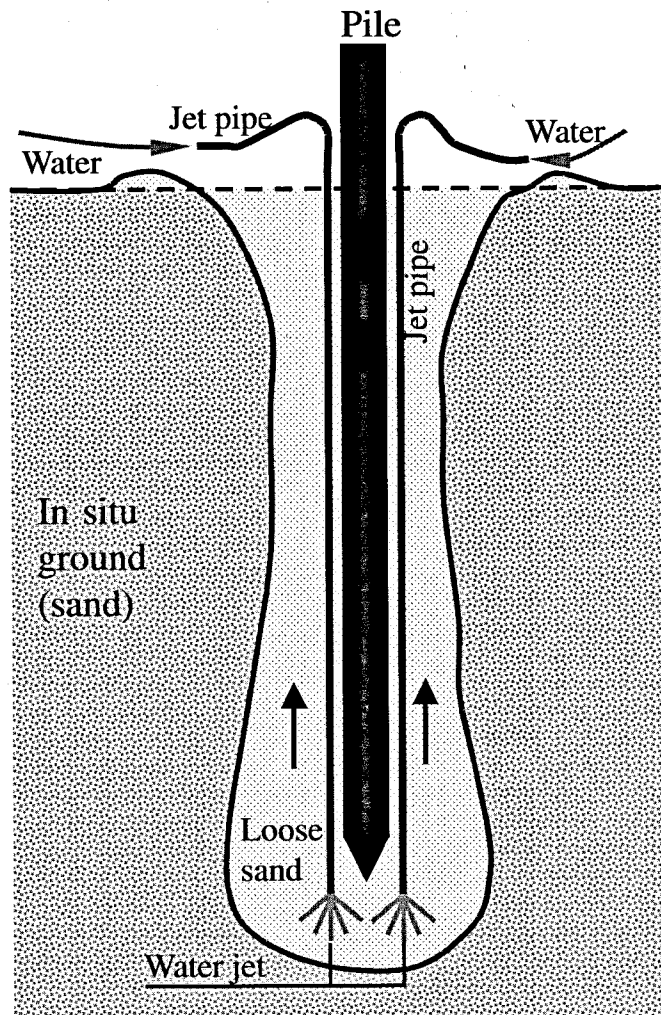

Toe nozzle pipe

The pile toe has a steel pipe in the horizontal direction for jetting water into the soil where the pile is to be inserted (Fig. 5). This toe pipe contains a large number of regularly spaced holes about 3 mm in diameter. The central pipe is connected with the toe pipe. Water from the central pipe is directed into the toe nozzle pipe and is jetted through the small holes into the soil.

I-beam

A steel I-beam is partially cast in the concrete sheet pile along one of its sides (Fig. 6). The I-beam is flanked by two semicircular channels.

Rectangular tube

A steel tube with rectangular cross-section (rectangular tube) is cast in the concrete sheet pile along the side opposite to the I-beam (Fig. 7). The rectangular tube has a narrow opening slightly thicker than the I-beam web but narrower than the I-beam flanges. The inner width of the rectangular tube is slightly larger than the width of the I-beam flange.

Fig. 2. New jetting methods for jetting of water from internal pipe within piles. (a) Jetting of water from one nozzle at a toe of a pile in the form of a cone. (b) Jetting of water from many smaller nozzles at a concrete sheet pile toe in the form of many downward flow lines with high speed.

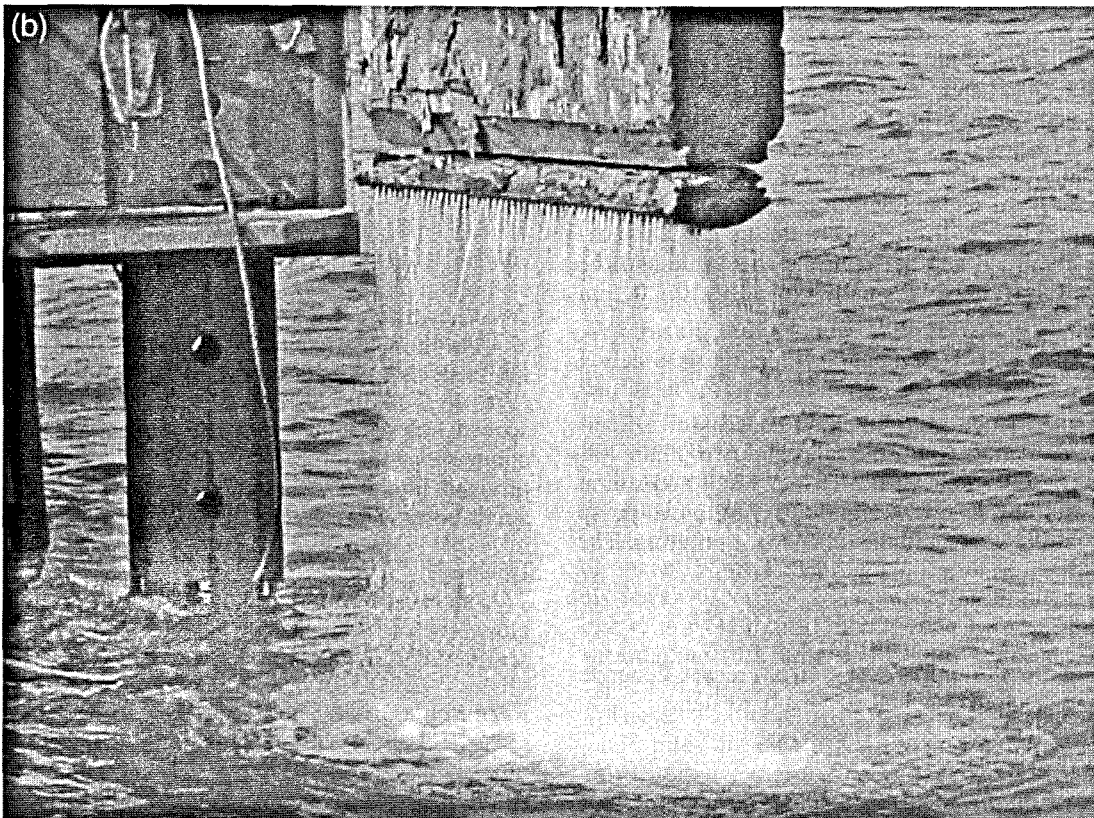

Fig. 2. New jetting methods for jetting of water from internal pipe within piles. (a) Jetting of water from one nozzle at a toe of a pile in the form of a cone. (b) Jetting of water from many smaller nozzles at a concrete sheet pile toe in the form of many downward flow lines with high speed.

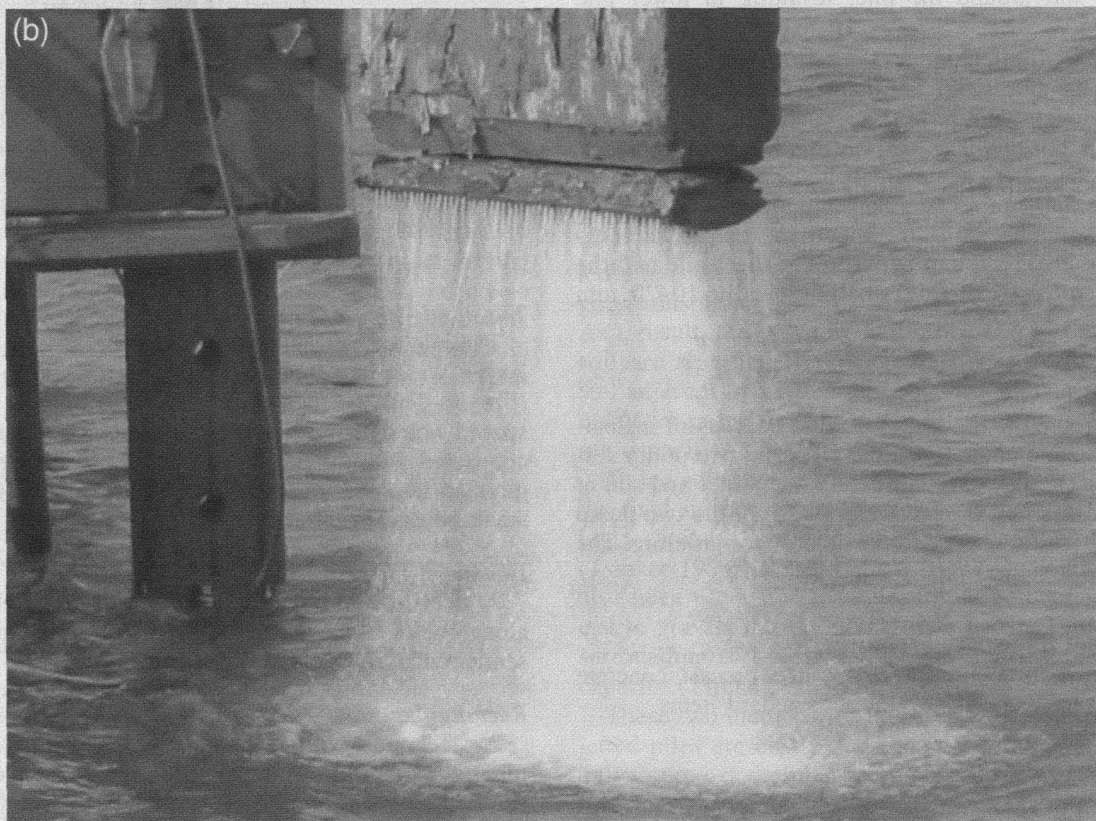

Fig. 3. General view of the grouted jetted precast concrete sheet piling method.

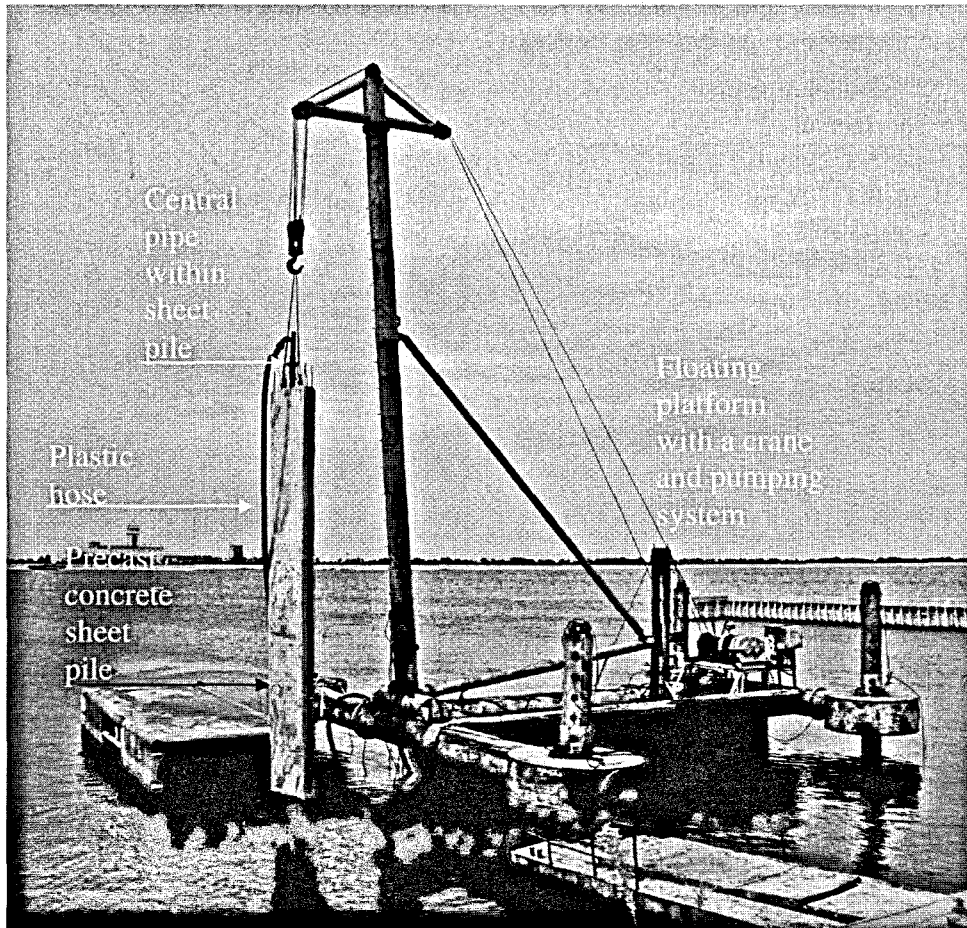
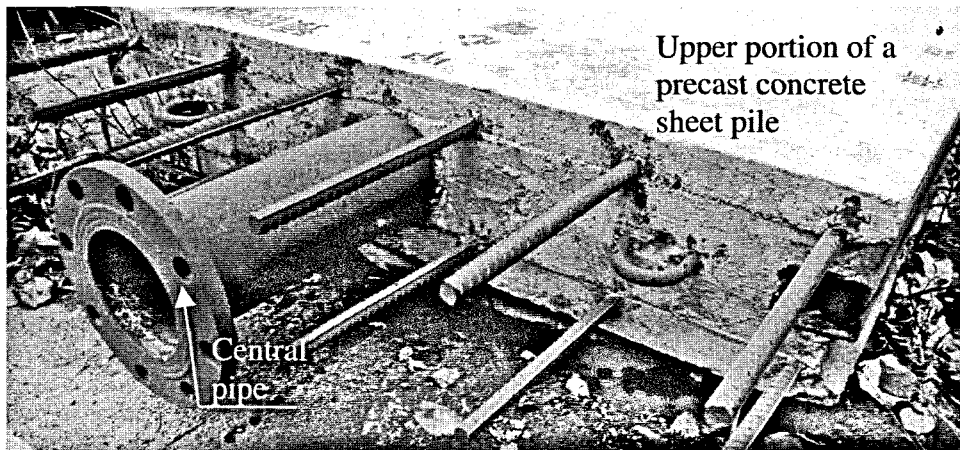

Fig. 4. Central pipe in precast concrete sheet pile for jetting and steel reinforcements for connection.



The inner length of the rectangular tube is longer than the length of the half web plus the thickness of the flange. The rectangular tube is also flanked by two semicircular channels cast in concrete.

The bottom ends of the I-beam, the rectangular tube, and the four semicircular open channels are 1 m above the sheet pile toe.

Jetting for pile driving

When the sheet pile is erected at the right position, water under pressure is pumped into the vertical central pipe via a plastic hose. The plastic hose is connected to a series of small nozzles at the pile toe, which jet the water into the soil (Fig. 2b). The pumping pressure is about 1.5 to 2.0 MPa. The total water discharge rate is about 50–80 L/s.

Fig. 3. General view of the grouted jetted precast concrete sheet piling method.

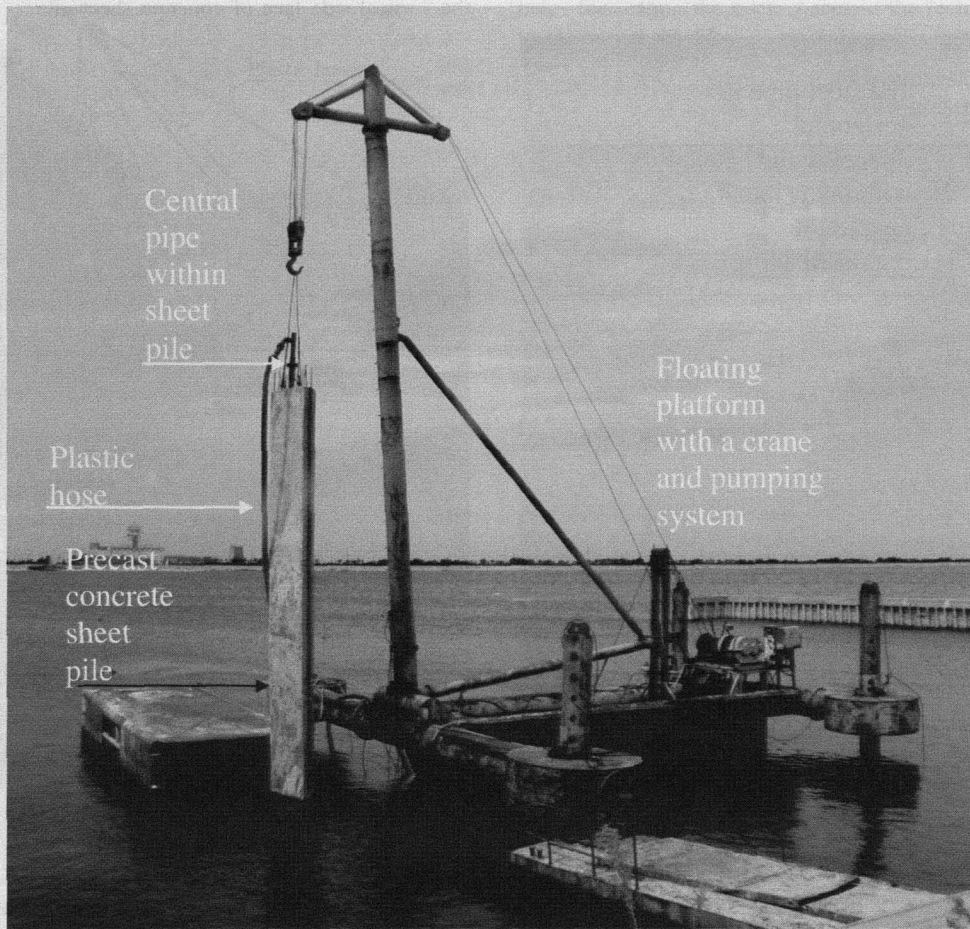
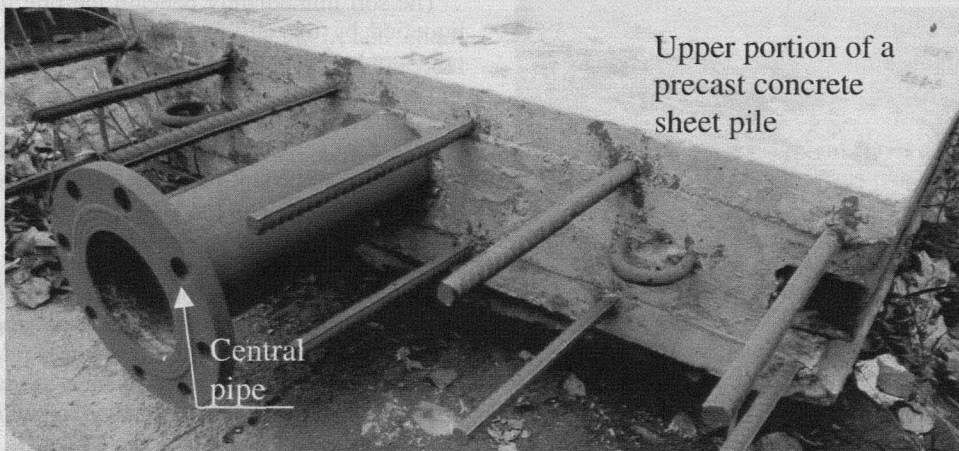

Fig. 4. Central pipe in precast concrete sheet pile for jetting and steel reinforcements for connection.



The inner length of the rectangular tube is longer than the length of the half web plus the thickness of the flange. The rectangular tube is also flanked by two semicircular channels cast in concrete.

The bottom ends of the I-beam, the rectangular tube, and the four semicircular open channels are 1 m above the sheet pile toe.

Jetting for pile driving

When the sheet pile is erected at the right position, water under pressure is pumped into the vertical central pipe via a plastic hose. The plastic hose is connected to a series of small nozzles at the pile toe, which jet the water into the soil (Fig. 2b). The pumping pressure is about 1.5 to 2.0 MPa. The total water discharge rate is about 50–80 L/s.

Fig. 5. Steel pipe with nozzles horizontally buried in sheet pile toe for jetting.

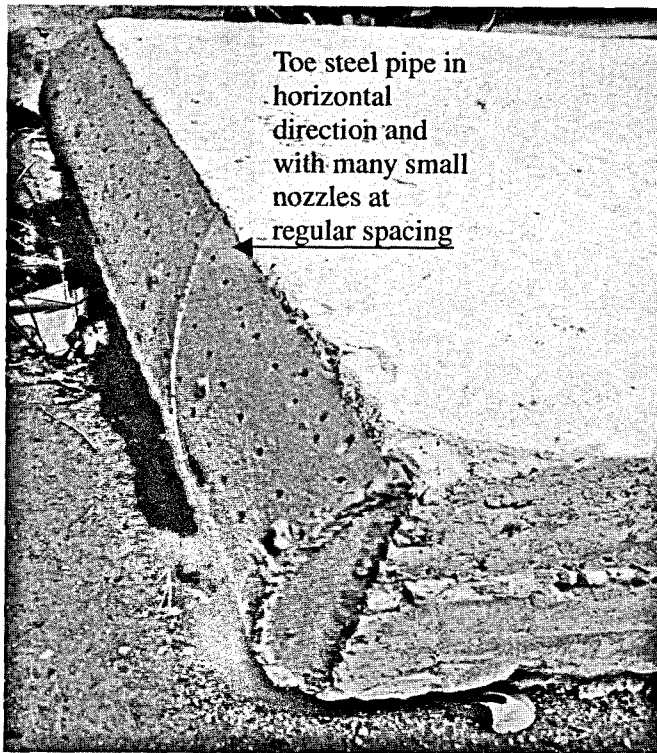

Toe steel pipe in horizontal direction and with many small nozzles at regular spacing

Fig. 7. Rectangular steel tube and two semicircular channels on the vertical side face of concrete sheet pile.

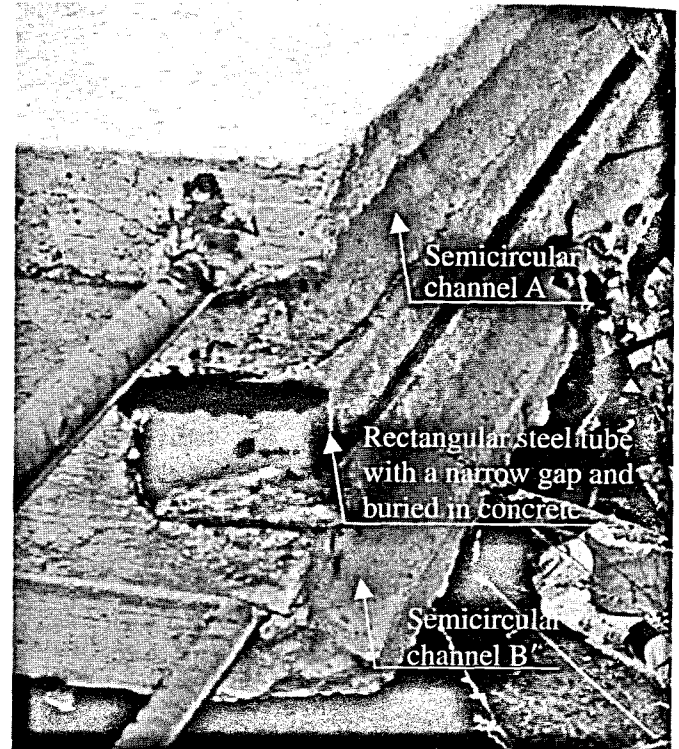

Semicircular channel A

Rectangular steel tube with a narrow gap and buried in concrete

Semicircular channel B

Fig. 6. I-shaped steel beam and two semicylindrical channels on the vertical side face of concrete sheet pile.

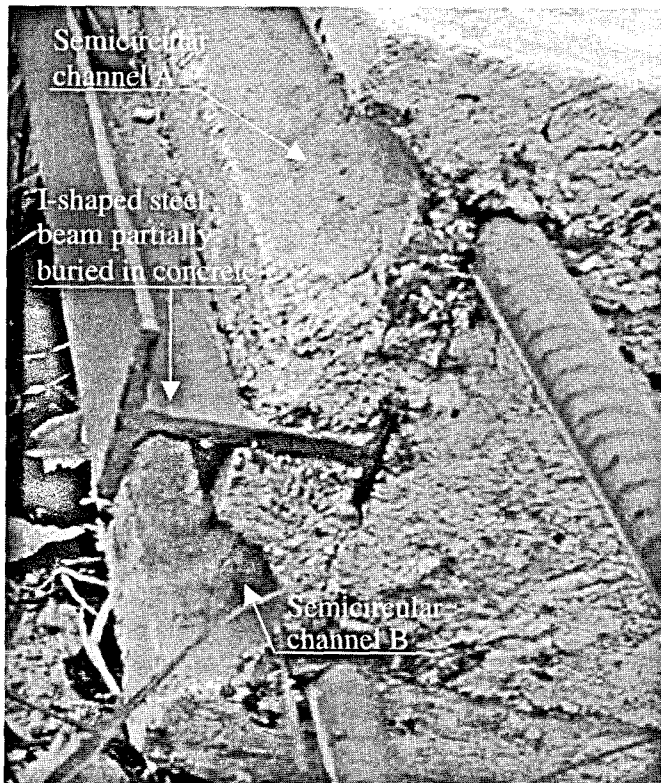

Semicircular channel A

I-shaped steel beam partially buried in concrete

Semicircular channel B

To ensure that the small holes at the pile toe do not become blocked with sand or gravel, the water for pumping and jetting should not contain any solid particles. Our experience suggests that the content of solid particles in the water should not be more than 0.1% of the total water weight.

The soil immediately beneath the pile toe is loosened and liquefied by the jetting action, enabling the concrete sheet pile, controlled by the crane, to sink into it by its own weight. The crane operator continues jetting until the pile reaches the design depth. When the pile sinks to a point about 0.5 m above its design depth, he reduces the water discharge rate and water pressure so as to minimize soil disturbance beneath the permanent pile toe.

Once the first pile has been installed, a similar process is used to install the second pile. Before jetting, the free flange of the I-beam on one vertical side face of the second sheet pile should be inserted into the rectangular tube on one vertical side face of the first sheet pile. The free flange of the second pile I-beam fits inside the rectangular tube of the first sheet pile. This process is repeated with all subsequent piles.

Figure 8 illustrates the pile installation technique. This technique reduces the width of the disturbed soil zone adjacent to the pile. Our experience has shown that the disturbed soil zone width is in the order of 10–20 mm.

Grouting for sheet pile connection

As described above, two sheet piles are installed side by side into the ground. One of the two I-beam flanges of the second sheet pile is inserted into the rectangular tube of the

Fig. 5. Steel pipe with nozzles horizontally buried in sheet pile toe for jetting.

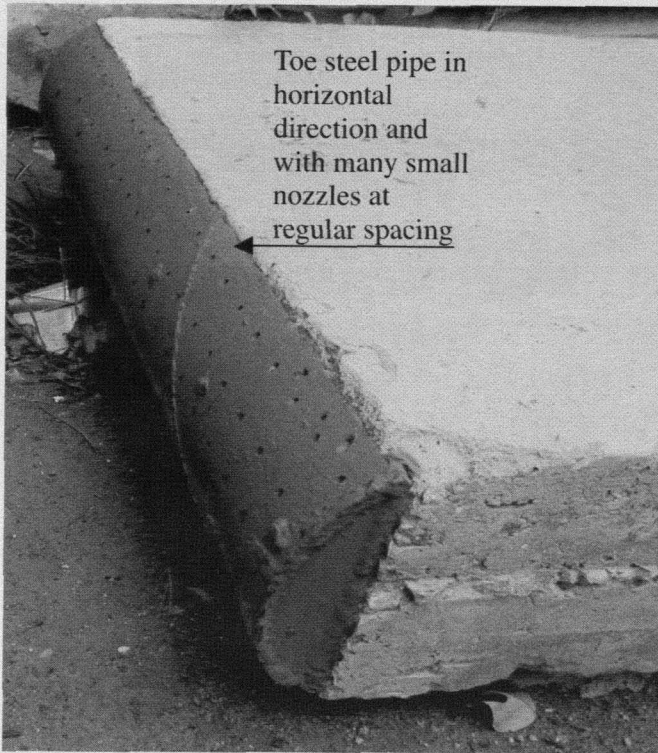

Fig. 7. Rectangular steel tube and two semicircular channels on the vertical side face of concrete sheet pile.

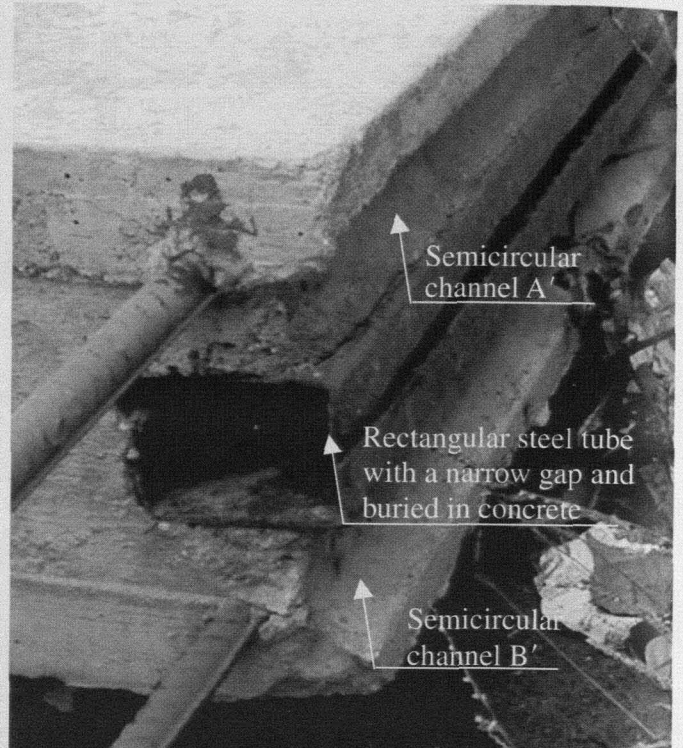
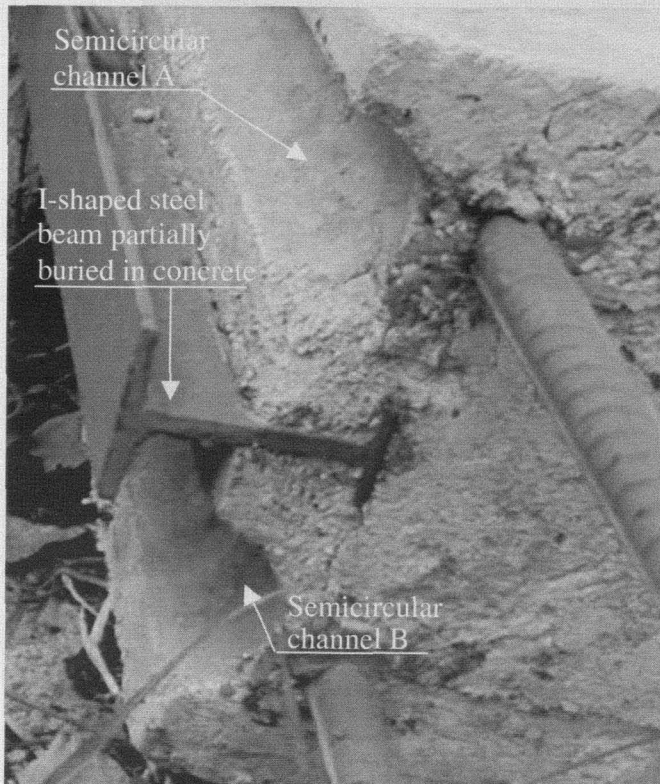

Fig. 6. I-shaped steel beam and two semicylindrical channels on the vertical side face of concrete sheet pile.



To ensure that the small holes at the pile toe do not become blocked with sand or gravel, the water for pumping and jetting should not contain any solid particles. Our experience suggests that the content of solid particles in the water should not be more than 0.1% of the total water weight.

The soil immediately beneath the pile toe is loosened and liquefied by the jetting action, enabling the concrete sheet pile, controlled by the crane, to sink into it by its own weight. The crane operator continues jetting until the pile reaches the design depth. When the pile sinks to a point about 0.5 m above its design depth, he reduces the water discharge rate and water pressure so as to minimize soil disturbance beneath the permanent pile toe.

Once the first pile has been installed, a similar process is used to install the second pile. Before jetting, the free flange of the I-beam on one vertical side face of the second sheet pile should be inserted into the rectangular tube on one vertical side face of the first sheet pile. The free flange of the second pile I-beam fits inside the rectangular tube of the first sheet pile. This process is repeated with all subsequent piles.

Figure 8 illustrates the pile installation technique. This technique reduces the width of the disturbed soil zone adjacent to the pile. Our experience has shown that the disturbed soil zone width is in the order of 10–20 mm.

Grouting for sheet pile connection

As described above, two sheet piles are installed side by side into the ground. One of the two I-beam flanges of the second sheet pile is inserted into the rectangular tube of the

Fig. 8. Sketch showing jetting sheet pile driven at pile toe.

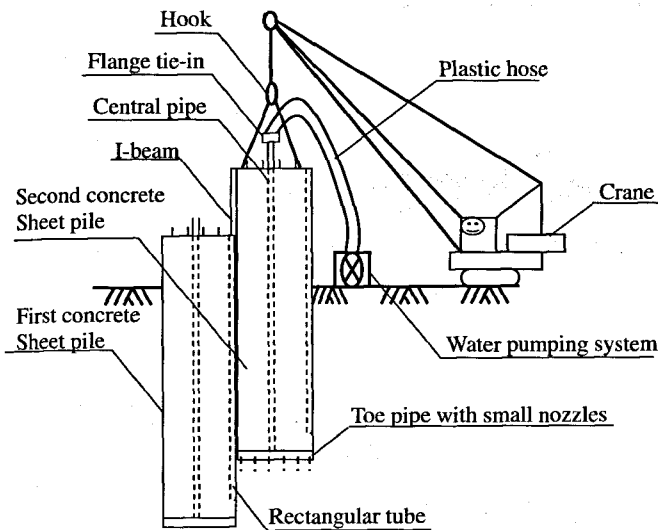
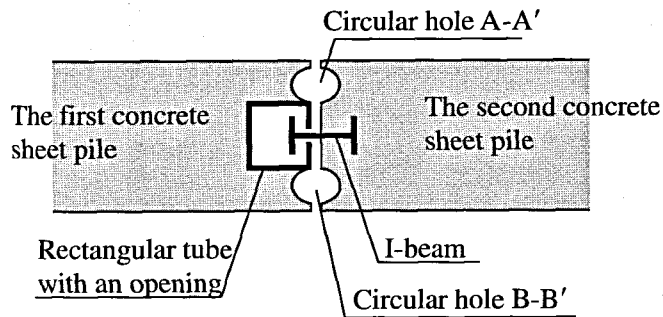

Fig. 9. Horizontal cross-section showing initial connection between two sheet piles before grouting.



first sheet pile. The corresponding four semicircular channels of the two sheet piles form two vertical cylindrical holes whose cross-sections A-A' and B-B' are shown in Fig. 9. Inevitably, the two cylindrical holes, the steel tube, and the gap between the sidewalls of the two concrete piles become filled with liquid mud. This must be cleaned away from the spaces at the pile connection before the tube hole and the wall gap are grouted. The procedure is described below.

Step 1: Isolating the liquid mud at the connection of two sheet piles

The mud must be isolated from the external source of soil and water surrounding the piles to be removed from the tube and the wall gap. The two vertical cylindrical holes A-A' and B-B' are designed to do this. The isolation procedure is as follows.

The two holes are also filled with liquid mud, which would affect the grout if it came into direct contact with the mud. To protect the grout from the liquid mud in each of the two holes, a long cylindrical bag is used. The bag is made of thin flexible plastic sheeting and is extremely flexible. The bag is slightly wider and longer than the vertical cylindrical holes A-A' and B-B'. It has only one opening at its head.

Fig. 10. Horizontal section showing the grouted two circular holes for sealing the open spaces in the rectangular tube and between two sheet piles.

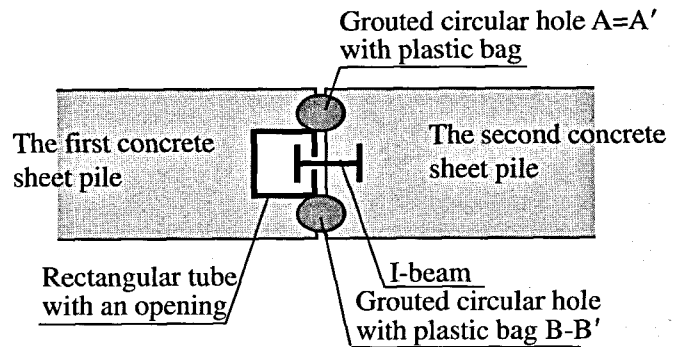

A small amount of fresh and liquid grout is poured into the top of the bag and allowed to settle at its bottom. The bottom of the bag is then inserted into the hole A-A'. The gravity force of the fresh grout stretches the bag vertically and carries the bag bottom down through the vertical hole to its base in the soil. Additional fresh grout is then poured into the bag above the pile head under low pressure. The mud in the hole is forced to flow out of the hole because of the pressure of the fresh grout in the bag. A similar procedure is used for the hole B-B'. The results are shown in Fig. 10.

Over time, the liquid grout in the two plastic bags in the holes A-A' and B-B' hardens. The hardened grout in a bag fully contacts the concrete surface of the piles as shown in Fig. 11 at Guang-nan reservoir. Consequently, the two hardened grout bags in the vertical holes A-A' and B-B' form two solid columns completely isolating the mud within the tube and the sidewall gap.

Step 2: Removing mud from the tube and wall gap

Subsequently, a steel pipe with a single nozzle at its end is inserted into the mud within the rectangular tube at the pile connection. Clean water is then pumped into the bottom end of the tube through the pipe to flush the mud out of the tube and the wall gap. Because of the isolation of the two grouted bags, the mud can be washed out and replaced by clean water. The mud mixes with the clean water and flows out of holes at the top of the tube and the wall gap.

Step 3: Grouting the tube with the I-beam at the connection

Fresh grout is then pumped into the bottom end of the tube through the steel pipe. The fresh grout gradually fills up the tube and the wall gap while the clean water in the tube and gap is being flushed out at the top because fresh grout is heavier than water. The process is completed when the fresh grout begins to flow out of the tube.

The steel pipe is then slowly pulled out of the tube, which is filled with fresh grout. The removal of the steel pipe may cause the fresh grout level in the tube and the wall gap to fall slightly, and additional grout may be added. The grout should have a unit weight of about 18 kN/m³.

Fig. 8. Sketch showing jetting sheet pile driven at pile toe.

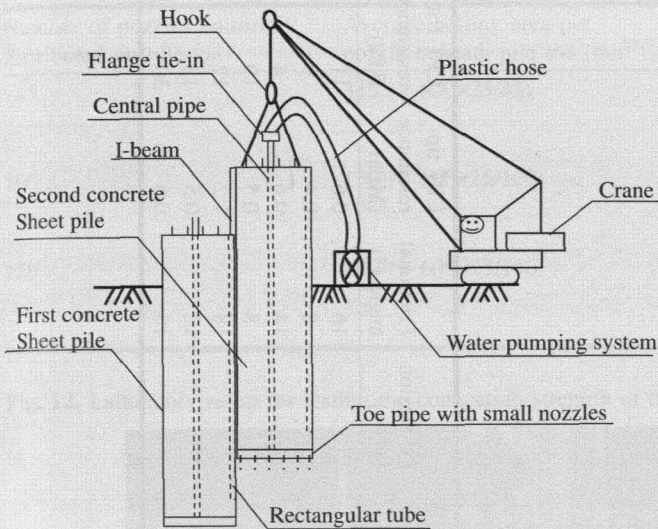
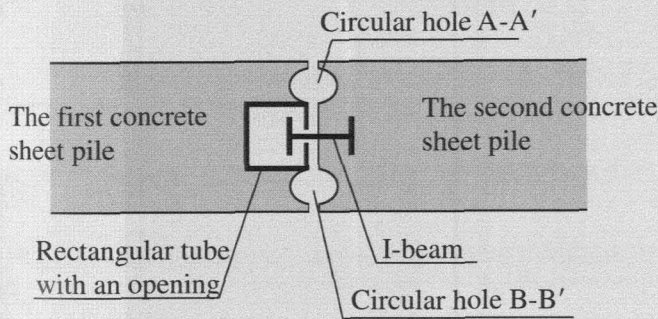

Fig. 9. Horizontal cross-section showing initial connection between two sheet piles before grouting.



first sheet pile. The corresponding four semicircular channels of the two sheet piles form two vertical cylindrical holes whose cross-sections A-A' and B-B' are shown in Fig. 9. Inevitably, the two cylindrical holes, the steel tube, and the gap between the sidewalls of the two concrete piles become filled with liquid mud. This must be cleaned away from the spaces at the pile connection before the tube hole and the wall gap are grouted. The procedure is described below.

Step 1: Isolating the liquid mud at the connection of two sheet piles

The mud must be isolated from the external source of soil and water surrounding the piles to be removed from the tube and the wall gap. The two vertical cylindrical holes A-A' and B-B' are designed to do this. The isolation procedure is as follows.

The two holes are also filled with liquid mud, which would affect the grout if it came into direct contact with the mud. To protect the grout from the liquid mud in each of the two holes, a long cylindrical bag is used. The bag is made of thin flexible plastic sheeting and is extremely flexible. The bag is slightly wider and longer than the vertical cylindrical holes A-A' and B-B'. It has only one opening at its head.

Fig. 10. Horizontal section showing the grouted two circular holes for sealing the open spaces in the rectangular tube and between two sheet piles.

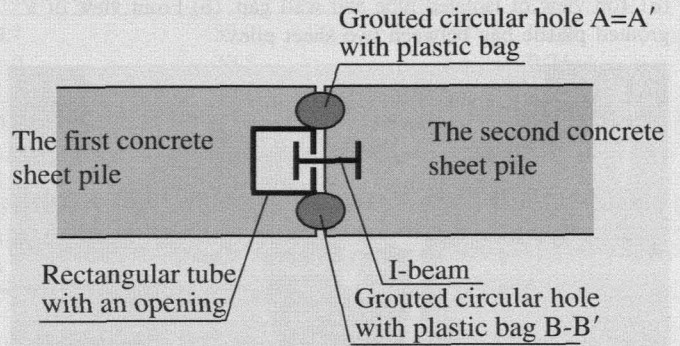

A small amount of fresh and liquid grout is poured into the top of the bag and allowed to settle at its bottom. The bottom of the bag is then inserted into the hole A-A'. The gravity force of the fresh grout stretches the bag vertically and carries the bag bottom down through the vertical hole to its base in the soil. Additional fresh grout is then poured into the bag above the pile head under low pressure. The mud in the hole is forced to flow out of the hole because of the pressure of the fresh grout in the bag. A similar procedure is used for the hole B-B'. The results are shown in Fig. 10.

Over time, the liquid grout in the two plastic bags in the holes A-A' and B-B' hardens. The hardened grout in a bag fully contacts the concrete surface of the piles as shown in Fig. 11 at Guang-nan reservoir. Consequently, the two hardened grout bags in the vertical holes A-A' and B-B' form two solid columns completely isolating the mud within the tube and the sidewall gap.

Step 2: Removing mud from the tube and wall gap

Subsequently, a steel pipe with a single nozzle at its end is inserted into the mud within the rectangular tube at the pile connection. Clean water is then pumped into the bottom end of the tube through the pipe to flush the mud out of the tube and the wall gap. Because of the isolation of the two grouted bags, the mud can be washed out and replaced by clean water. The mud mixes with the clean water and flows out of holes at the top of the tube and the wall gap.

Step 3: Grouting the tube with the I-beam at the connection

Fresh grout is then pumped into the bottom end of the tube through the steel pipe. The fresh grout gradually fills up the tube and the wall gap while the clean water in the tube and gap is being flushed out at the top because fresh grout is heavier than water. The process is completed when the fresh grout begins to flow out of the tube.

The steel pipe is then slowly pulled out of the tube, which is filled with fresh grout. The removal of the steel pipe may cause the fresh grout level in the tube and the wall gap to fall slightly, and additional grout may be added. The grout should have a unit weight of about 18 kN/m³.

Fig. 11. Photographs showing the steel tube and I-beam and internal spaces between two concrete sheet piles isolated with two grouted plastic bags within the two circular cylindrical holes. (a) Top view of isolated tube and wall gap. (b) Front view of a grouted plastic bag between two sheet piles.

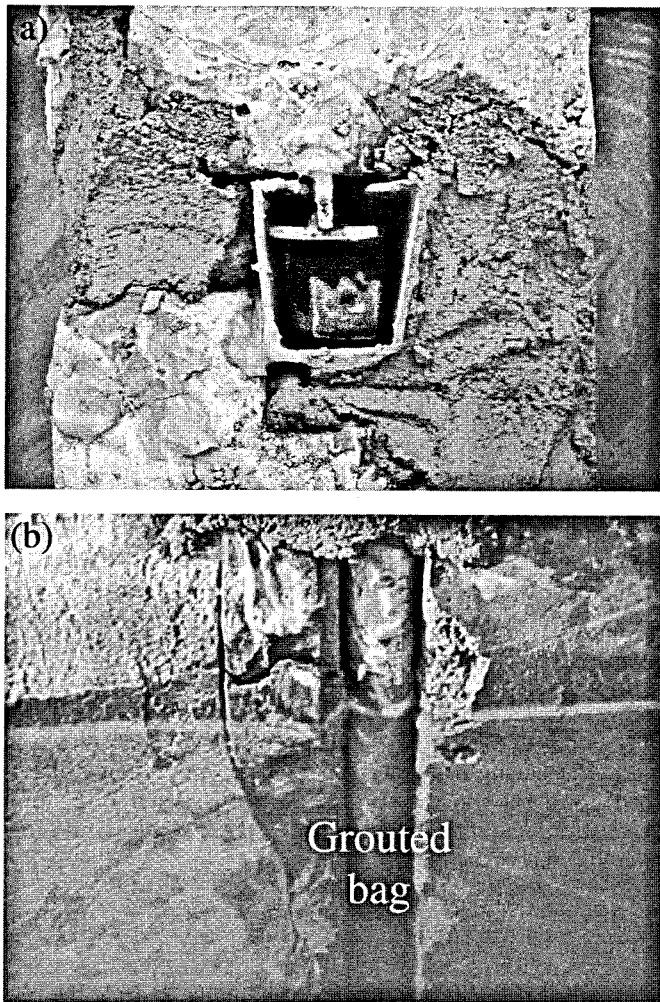

Grouting the open space of the toe pipe and central pipe

To improve the structural strength of the pile the internal spaces of the toe pipe and the central pipe must be grouted. Clean water is pumped into the toe pipe through the steel pipe to flush out the mud within the toe pipe and the central pipe. Fresh grout is then pumped into the toe pipe to fill the internal spaces of the toe pipe and the central pipe.

The central steel pipe should be removed before cleaning and grouting. The concrete sheet pile should be designed and built to enable the central pipe to be retrieved after pile installation.

Grouting for strengthening disturbed soils

The soils beneath and immediately adjacent to the concrete sheet pile are disturbed and loosened. Although the disturbed soils are within 10–20 mm, it may be necessary to strengthen them with grouting. Fresh grout can be pumped into the disturbed zones through the steel pipe after it is in-

Table 1. Representative values of the soil physical and mechanical properties for testing pile driving speed by jetting.

Strata No.	Soil type	Bottom depth (m)	Specific gravity	Natural water content (%)	Natural weight (kN/m ³)	Natural unit			Elastic modulus of deformation (MPa)	Cohesion (kPa)	Frictional angle (°)	CPT tip resistance (MPa)	CPT friction resistance (kPa)
						Natural water content (%)	Natural weight (kN/m ³)	Natural unit					
1	Silt	2.2	2.68	28.1	19.1	0.80	30.1	18.9	12.2	10	16	0.6	11
2	Clay	2.9	2.74	41.8	18.0	1.15	47.0	23.3	3.7	16	8	0.4	9
3	Silt	5.5	2.70	31.1	19.0	0.86	31.3	17.9	11.8	11	14	0.6	4
4	Clay	6.9	2.74	39.8	18.1	1.12	43.1	21.8	3.5	14	8	0.5	19
5	Silty clay	9.6	2.67	26.1	19.5	0.72	27.3	19.3	4.3	5	18	1.2	12
6	Silt	13.1	2.69	31.5	18.9	0.87	27.7	15.1	9.3	10	12	0.5	18
7	Silty clay	14.4	2.67	23.3	19.5	0.76	25.7	18.2	6.1	7	16	0.6	30

Fig. 11. Photographs showing the steel tube and I-beam and internal spaces between two concrete sheet piles isolated with two grouted plastic bags within the two circular cylindrical holes. (a) Top view of isolated tube and wall gap. (b) Front view of a grouted plastic bag between two sheet piles.

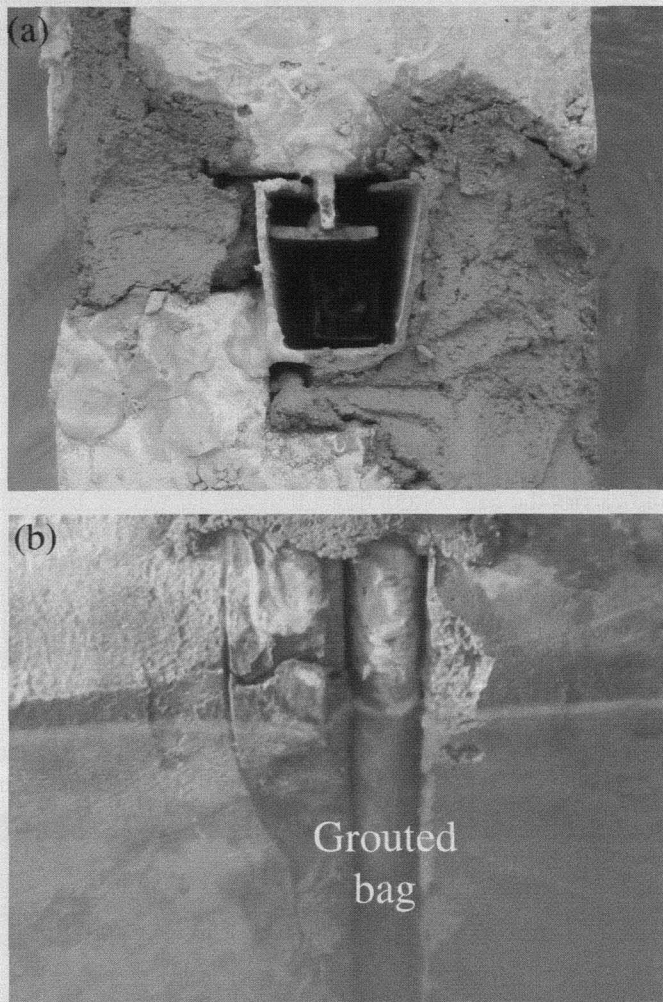

Grouting the open space of the toe pipe and central pipe

To improve the structural strength of the pile the internal spaces of the toe pipe and the central pipe must be grouted. Clean water is pumped into the toe pipe through the steel pipe to flush out the mud within the toe pipe and the central pipe. Fresh grout is then pumped into the toe pipe to fill the internal spaces of the toe pipe and the central pipe.

The central steel pipe should be removed before cleaning and grouting. The concrete sheet pile should be designed and built to enable the central pipe to be retrieved after pile installation.

Grouting for strengthening disturbed soils

The soils beneath and immediately adjacent to the concrete sheet pile are disturbed and loosened. Although the disturbed soils are within 10–20 mm, it may be necessary to strengthen them with grouting. Fresh grout can be pumped into the disturbed zones through the steel pipe after it is in-

Table 1. Representative values of the soil physical and mechanical properties for testing pile driving speed by jetting.

Strata No.	Soil type	Bottom depth (m)	Specific gravity	Natural water content (%)	Natural weight (kN/m ³)	Void ratio	Liquid limit (%)	Plastic limit (%)	Elastic modulus of deformation (MPa)	Cohesion (kPa)	Frictional angle (°)	CPT tip resistance (MPa)	CPT friction resistance (kPa)
1	Silt	2.2	2.68	28.1	19.1	0.80	30.1	18.9	12.2	10	16	0.6	11
2	Clay	2.9	2.74	41.8	18.0	1.15	47.0	23.3	3.7	16	8	0.4	9
3	Silt	5.5	2.70	31.1	19.0	0.86	31.3	17.9	11.8	11	14	0.6	4
4	Clay	6.9	2.74	39.8	18.1	1.12	43.1	21.8	3.5	14	8	0.5	19
5	Silty clay	9.6	2.67	26.1	19.5	0.72	27.3	19.3	4.3	5	18	1.2	12
6	Silt	13.1	2.69	31.5	18.9	0.87	27.7	15.1	9.3	10	12	0.5	18
7	Silty clay	14.4	2.67	23.3	19.5	0.76	25.7	18.2	6.1	7	16	0.6	30

Table 2. Results of the sheet pile driving speed by jetting with different pressure and nozzles.

Number of nozzles uniformly distributed on pile toe	Average cutting area per nozzle beneath pile toe (mm ²)	Pressure of jetted water (MPa)	Total time for driving pile 7.3 m into soil (min)	Driving speed (m/min)
45	333 (= 600×25/45)	0.7	39.0	0.18
		1.0	30.5	0.24
		1.3	26.5	0.28
100	150 (= 600×25/100)	0.7	33.0	0.22
		1.0	19.0	0.38
		1.3	10.6	0.69
150	100 (= 600×25/150)	0.7	28.0	0.26
		1.0	17.5	0.42
		1.3	8.0	0.91

Fig. 12. Laboratory setup for testing the connection strength of three concrete panels.

serted into the pile toe area. Once the fresh grout filled in the disturbed soil zones consolidates and hardens, the grouted soils will have higher shear strength to support the pile.

Main construction steps

The grouted jetted precast concrete sheet piling method includes the following main construction steps:

- (i) casting specially designed concrete sheet piles for jetting, grouting, and connection,
- (ii) jetting to drive the precast concrete piles by their own weight into soil from either a floating or anchored piling platform,
- (iii) cleaning and grouting the connection zone between two concrete sheet piles and the internal pipes in the sheet piles,

(iv) grouting the disturbed soil zones beneath and adjacent to the pile, and

(v) constructing pile caps to integrate and strengthen the grouted and jetted precast concrete sheet piles.

In the following section, we present the results of laboratory experiments and field tests to assess the new piling method.

Experiments and results

Jetting driving speed

The purpose of the first field trial was to determine the optimum jetting speed by varying the number of small nozzle holes and the jetting pressure. The experiment was conducted at a site in northern China at the mouth of the Yellow River. The soil had seven strata consisting of clay, silty clay,

Table 2. Results of the sheet pile driving speed by jetting with different pressure and nozzles.

Number of nozzles uniformly distributed on pile toe	Average cutting area per nozzle beneath pile toe (mm ²)	Pressure of jetted water (MPa)	Total time for driving pile 7.3 m into soil (min)	Driving speed (m/min)
45	333 (= 600×25/45)	0.7	39.0	0.18
		1.0	30.5	0.24
		1.3	26.5	0.28
100	150 (= 600×25/100)	0.7	33.0	0.22
		1.0	19.0	0.38
		1.3	10.6	0.69
150	100 (= 600×25/150)	0.7	28.0	0.26
		1.0	17.5	0.42
		1.3	8.0	0.91

Fig. 12. Laboratory setup for testing the connection strength of three concrete panels.

serted into the pile toe area. Once the fresh grout filled in the disturbed soil zones consolidates and hardens, the grouted soils will have higher shear strength to support the pile.

Main construction steps

The grouted jetted precast concrete sheet piling method includes the following main construction steps:

- (i) casting specially designed concrete sheet piles for jetting, grouting, and connection,
- (ii) jetting to drive the precast concrete piles by their own weight into soil from either a floating or anchored piling platform,
- (iii) cleaning and grouting the connection zone between two concrete sheet piles and the internal pipes in the sheet piles,

(iv) grouting the disturbed soil zones beneath and adjacent to the pile, and

(v) constructing pile caps to integrate and strengthen the grouted and jetted precast concrete sheet piles.

In the following section, we present the results of laboratory experiments and field tests to assess the new piling method.

Experiments and results

Jetting driving speed

The purpose of the first field trial was to determine the optimum jetting speed by varying the number of small nozzle holes and the jetting pressure. The experiment was conducted at a site in northern China at the mouth of the Yellow River. The soil had seven strata consisting of clay, silty clay,

Table 3. Representative values of the soil physical and mechanical properties for static loading tests of single jetted sheet piles.

Strata No.	Soil type	Bottom depth (m)	Specific gravity	Natural water content (%)	Natural weight unit (kN/m ³)	Void ratio	Liquid limit (%)	Plastic limit (%)	Elastic modulus of deformation (MPa)	Cohesion (kPa)	Frictional angle (°)	CPT tip resistance (MPa)	CPT friction resistance (kPa)
1	Silty clay	4.8	2.68	19.4	20.0	0.61	25.1	14.1	6.3	11	35	1.6	30
2	Silt	9.4	2.67	27.2	19.7	0.73	29.7	21.4	19.4	9	36	2.4	30
3	Silty clay	9.9	2.70	35.7	18.9	0.94	34.9	19.8	4.2	8	21	1.0	10
4	Silt	10.6	2.68	26.5	19.7	0.72	29.0	21.1	18.2	10	33	2.0	30
5	Clay	11.9	2.74	40.3	18.1	1.14	45.2	22.3	3.2	3	6	0.8	8
6	Silt	13.9	2.67	23.8	20.1	0.66	28.6	20.3	20.0	8	40	4.0	40
7	Mud clay	17.4	2.74	45.7	17.5	1.28	42.8	21.3	4.4	6	11	1.0	10

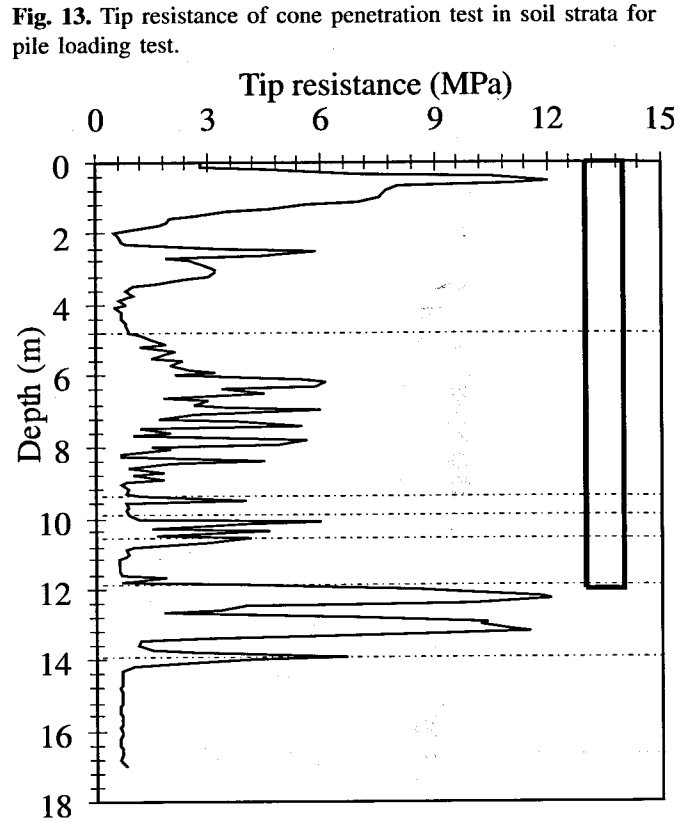

Fig. 13. Tip resistance of cone penetration test in soil strata for pile loading test.

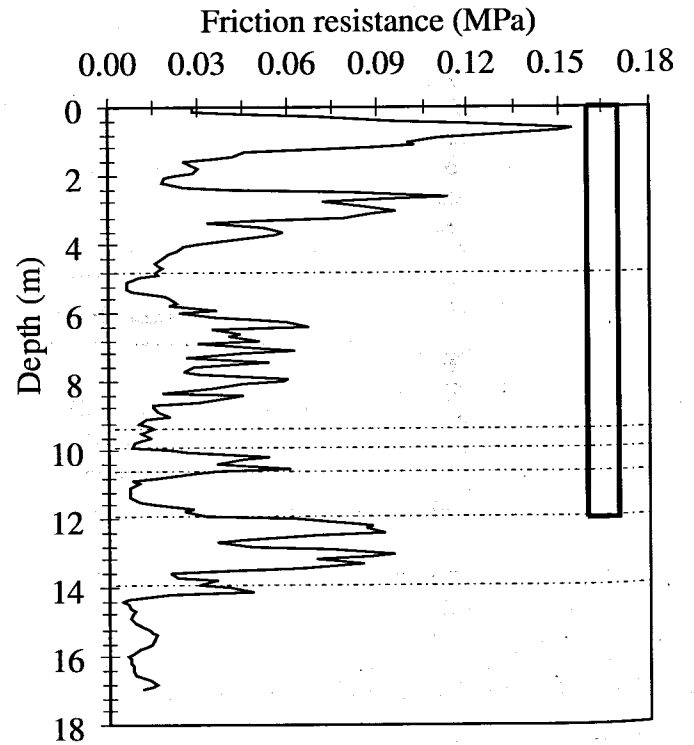

Fig. 14. Friction resistance of cone penetration test in soil strata for pile loading test.

Fig. 15. Axial force distribution with depth in the first sheet pile with grout.

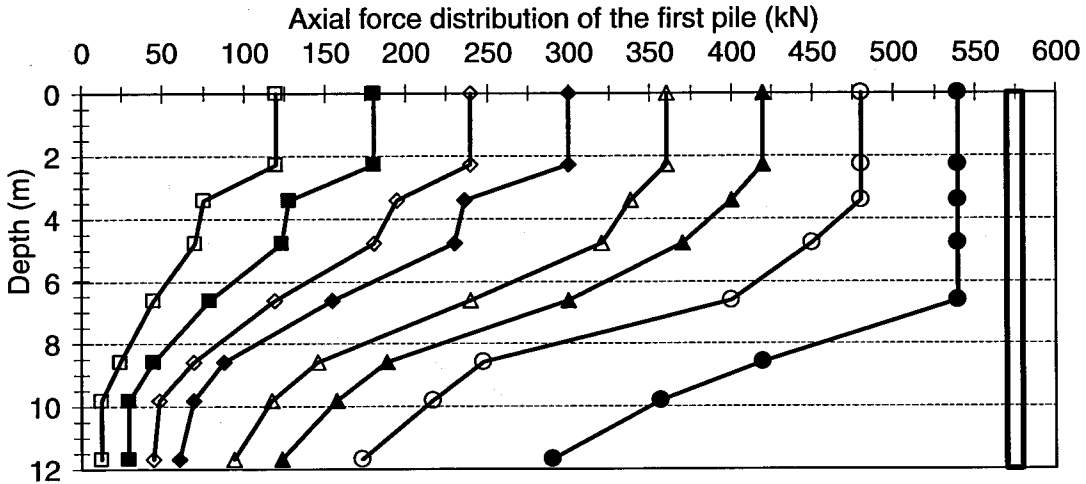

Fig. 16. Axial force distribution with depth in the second sheet pile without grout.

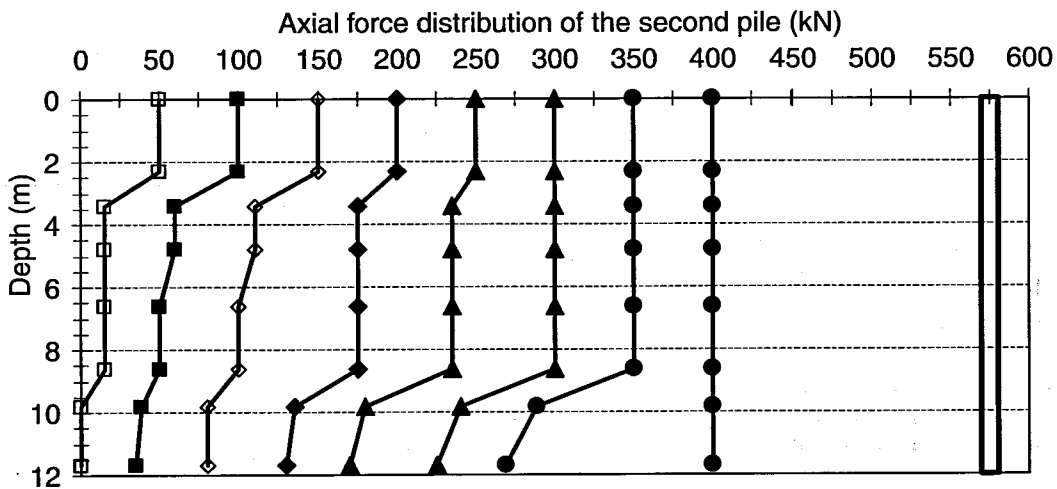

Fig. 17. Pile head settlement with applied load for the first sheet pile with grout.

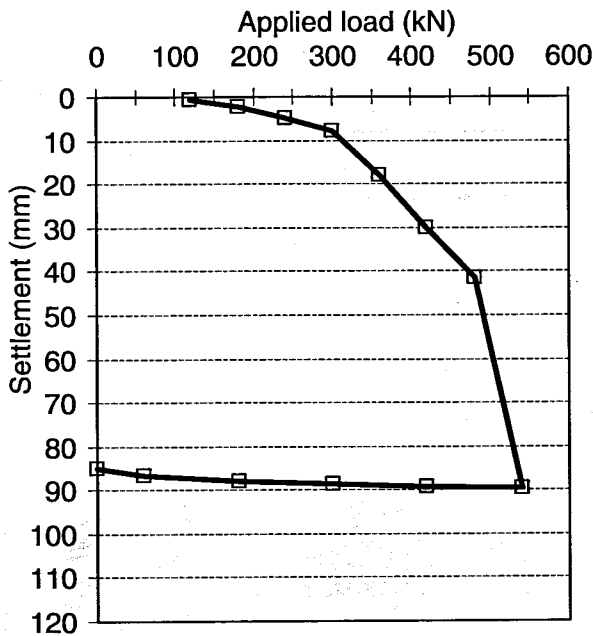

Fig. 18. Pile head settlement with applied load for the second sheet pile without grout.

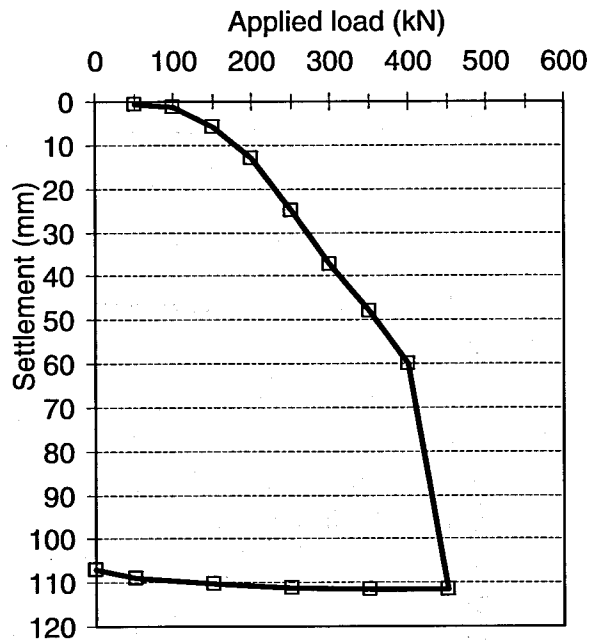

Fig. 19. Photograph showing a trial pit adjacent to a concrete sheet pile.

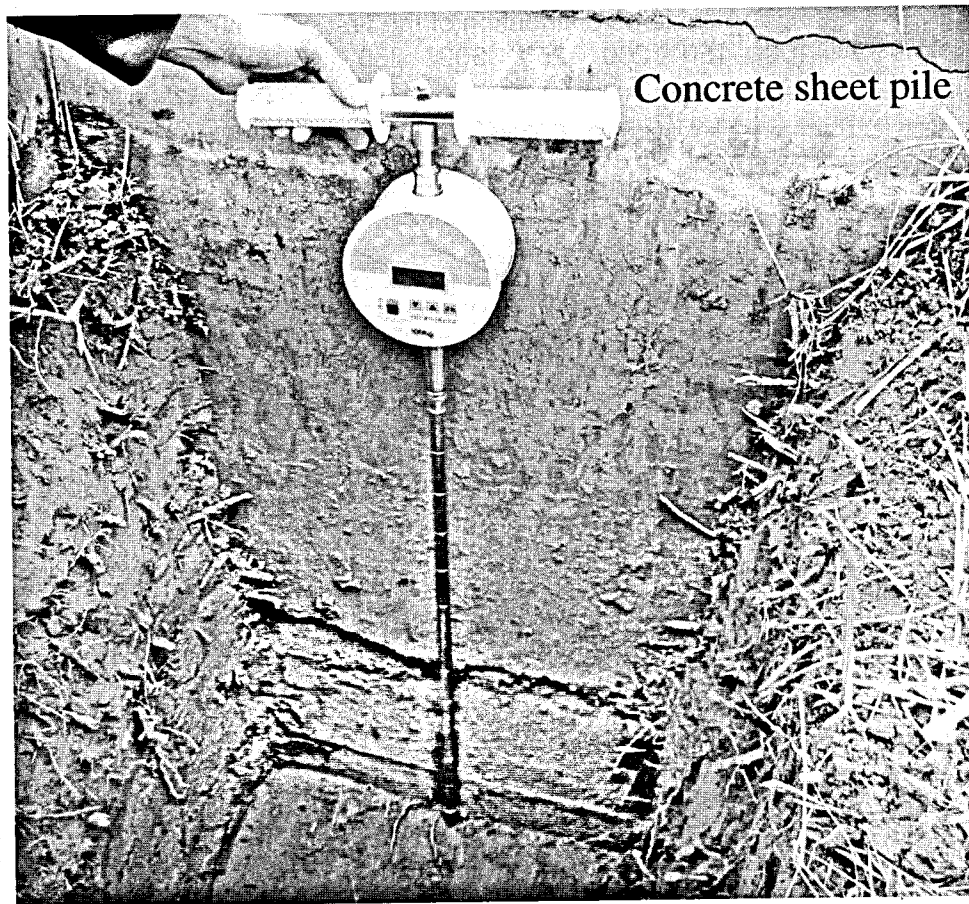

Fig. 20. Photograph showing the soil condition at the bottom of the trial pit in Fig. 19.

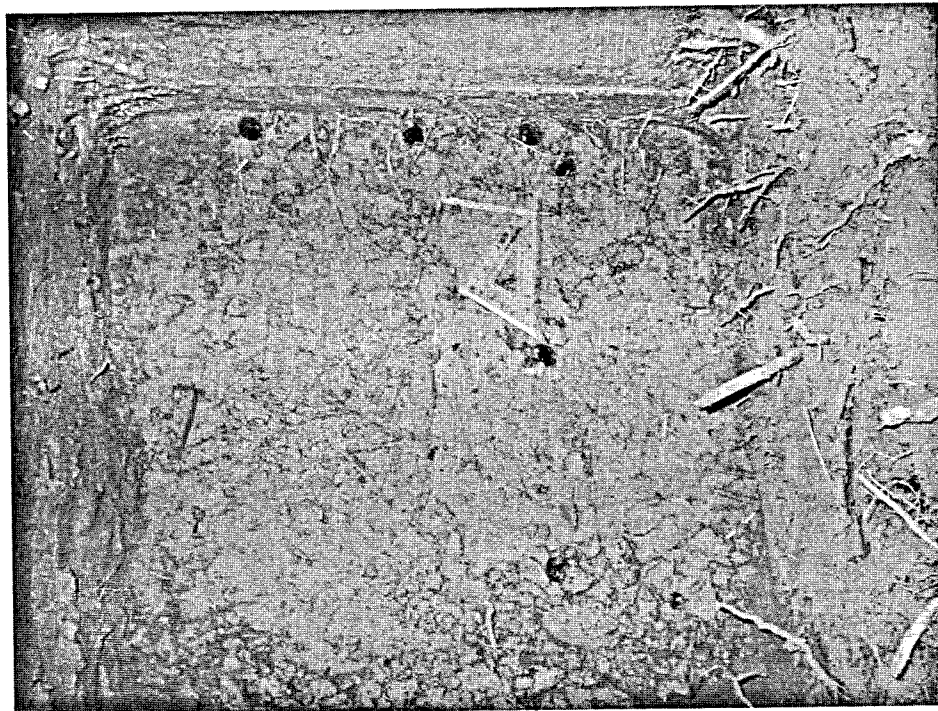

Fig. 19. Photograph showing a trial pit adjacent to a concrete sheet pile.

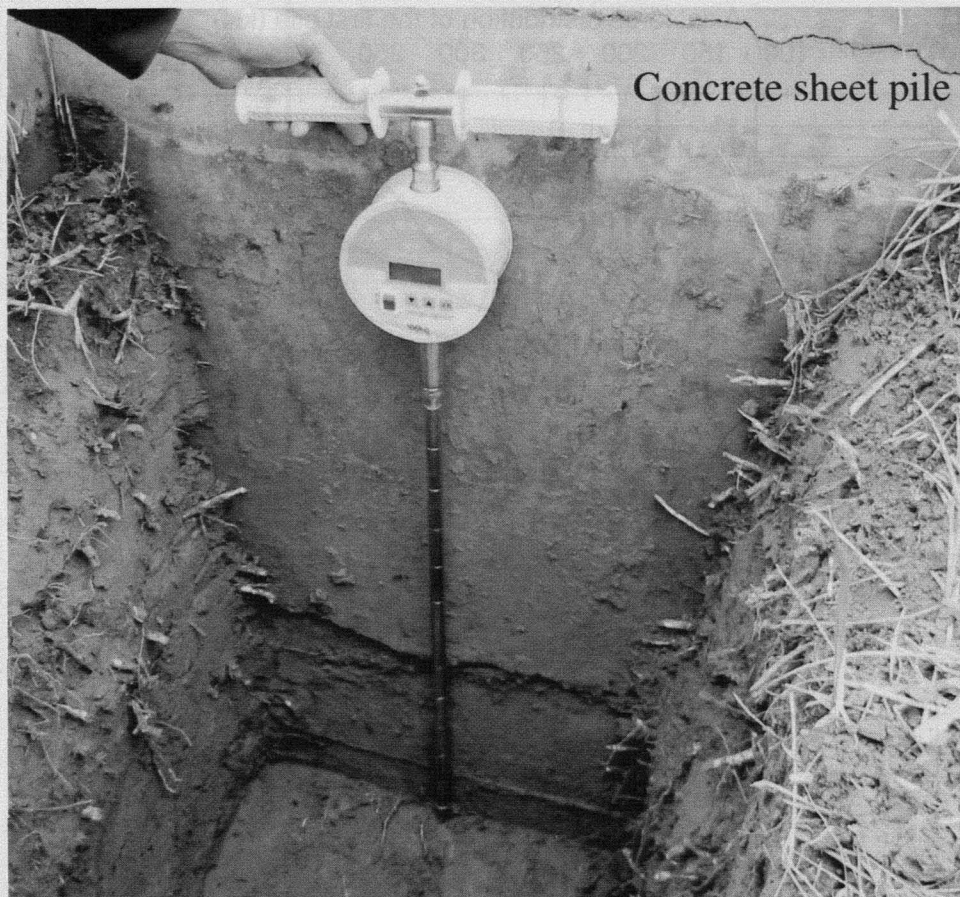

Fig. 20. Photograph showing the soil condition at the bottom of the trial pit in Fig. 19.

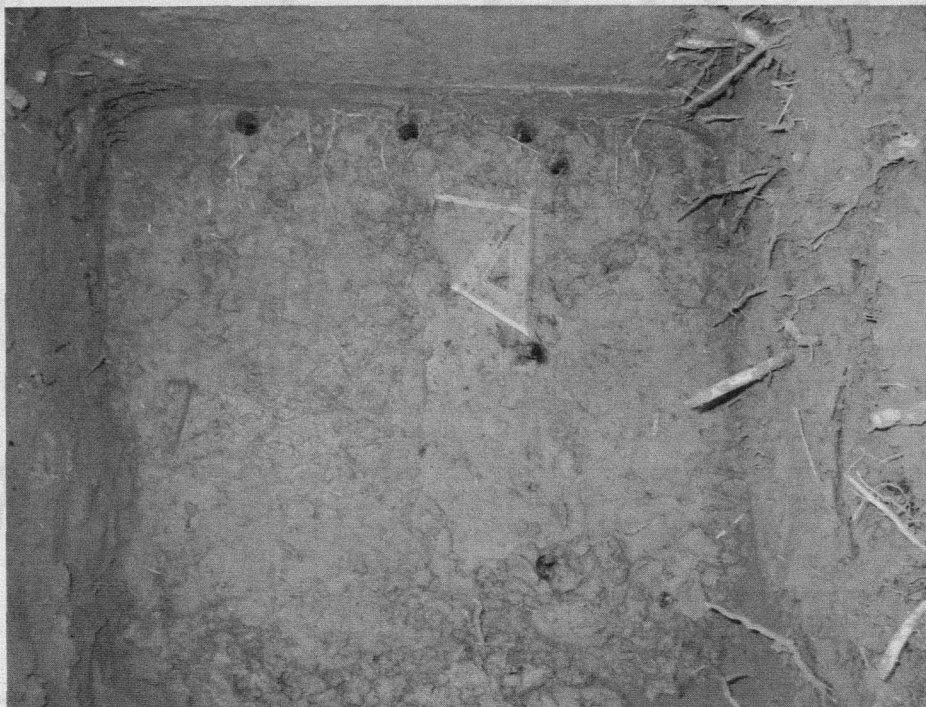
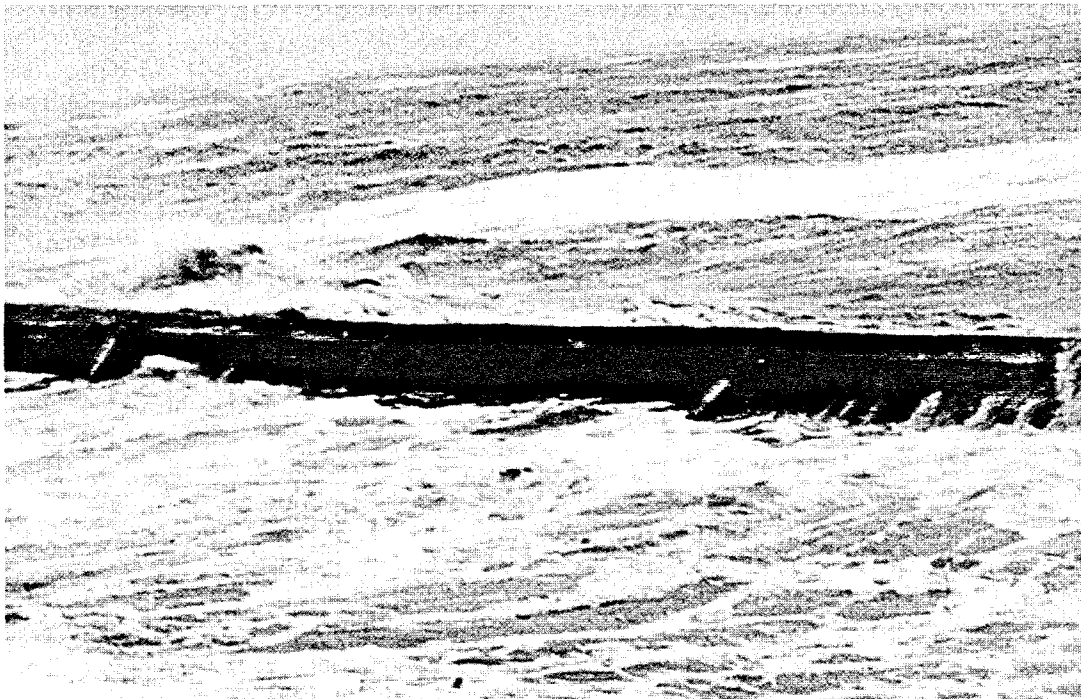

Fig. 21. Breakwater constructed with grouted jetted precast concrete sheet piling method in near shore of Bohai Sea, China.



and silt from ground surface to a depth of 14.4 m. The groundwater table was near the ground surface. Details of the physical and mechanical properties of the soils are given in Table 1. The concrete sheet pile was 8.0 m in length, 0.6 m in width, and 0.25 m in thickness. The central pipe diameter was 100 mm. Three toe pipes of equal size were used, one with 45 small nozzle holes, the second with 100, and the third with 150. All the holes had a uniform diameter of 3.2 mm. The pile was driven into soil for 7.30 m by jetting. Three different water pressures (0.7, 1.0, and 1.3 MPa) were used.

The results of these nine different combinations are listed in Table 2. Basically, the greater the number of nozzle holes and the higher the water pressure, the faster the speed of installation.

Connection strength of sheet piles

Laboratory tests were carried out to examine the strength of sheet piles at their connections (Fig. 12). Three concrete panels (left, middle, and right) were used. The three panels were fixed together using the method described above, where the steel I-beam and tube were used as the reinforcement for the grouting. The I-beam had its cross-section dimensions as follows: flange length equal to 80 mm, web width equal to 40 mm, and wall thickness equal to 4 mm. The steel tube had its cross-section dimensions as follows: length equal to 80 mm, width equal to 60 mm, wall thickness equal to 4 mm, and the opening gap equal to 10 mm. Each of the three concrete panels was 0.30 m long, 0.15 m wide, and 0.30 m thick.

The middle panel was placed 0.05 m above the left and right panels. The connection between the middle panel and each of the other two panels was 0.25 m high and 0.30 m

wide. The test was carried out on the 28th day after grouting of the two connections of the three panels. A first steel plate was placed above the middle panel. A second steel plate on the support platform was placed beneath the left and right panels. An axial load was applied to the first steel plate on the upper surface of the middle panel and was then transferred to the second steel plate with the left and right panels.

Three failure tests were conducted. The axial load for the failure at the two connections of the three panels was about 316 kN. The failures were found within the panel concrete for the steel I-beam or tube. The grouted connections between the left panel and the middle panel or between the middle panel and the right panel did not fail. The average shear strength of the panel connections for three tests was equal to 2.1 MPa (i.e., 316 kN/(0.25 m × 0.30 m)/2).

Static load tests of individual sheet piles

Static pile load tests were carried out on two individual concrete sheet piles at Guang-nan reservoir. The two sheet piles were jetted into ground at a site near the mouth of the Yellow River. The two sheet piles were 12 m long. Their cross-sections were rectangular and were 1 m wide and 0.3 m thick. The two piles were driven into the soil stratum completely by jetting. The disturbed soil zone adjacent to the first sheet pile was strengthened by grouting. The grouting was not applied to the second sheet pile. The two piles were completely buried in soil strata. The static loading tests were conducted on the 60th day after pile installation. Strain gauges were also installed on the steel reinforcements of the two sheet piles at different depths:

The soils had the following seven strata: silty clay, silt, silty clay, silt, clay, silt, and mud clay. The groundwater table was 3.5 m below the ground surface. The soil physical

Fig. 21. Breakwater constructed with grouted jetted precast concrete sheet piling method in near shore of Bohai Sea, China.

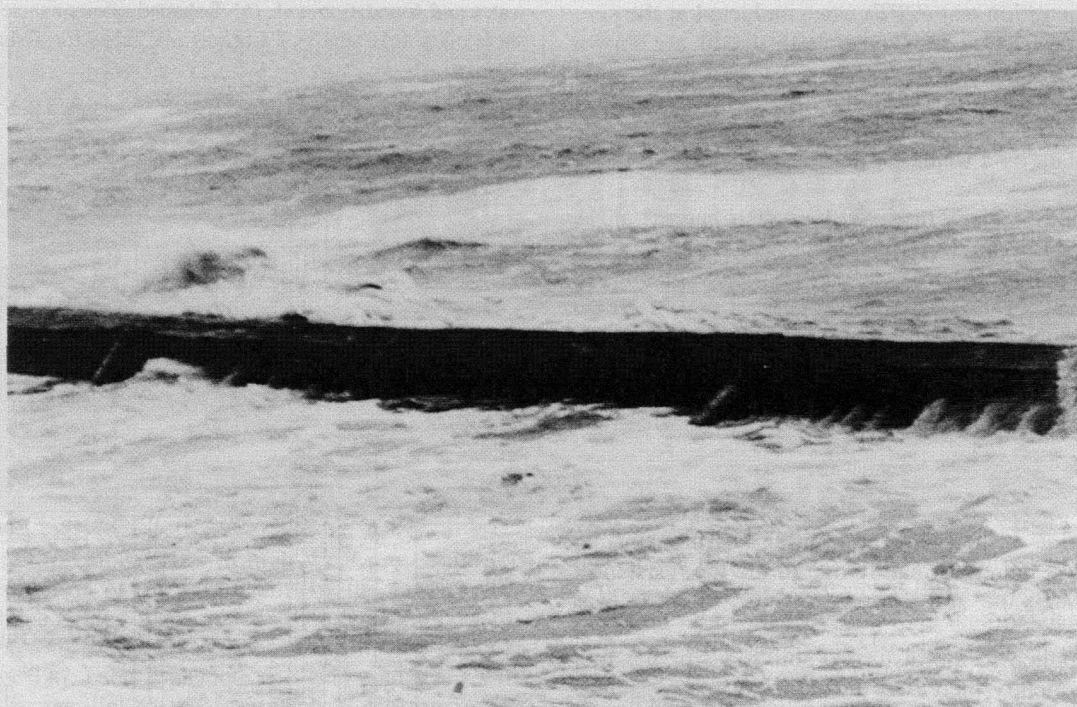

and silt from ground surface to a depth of 14.4 m. The groundwater table was near the ground surface. Details of the physical and mechanical properties of the soils are given in Table 1. The concrete sheet pile was 8.0 m in length, 0.6 m in width, and 0.25 m in thickness. The central pipe diameter was 100 mm. Three toe pipes of equal size were used, one with 45 small nozzle holes, the second with 100, and the third with 150. All the holes had a uniform diameter of 3.2 mm. The pile was driven into soil for 7.30 m by jetting. Three different water pressures (0.7, 1.0, and 1.3 MPa) were used.

The results of these nine different combinations are listed in Table 2. Basically, the greater the number of nozzle holes and the higher the water pressure, the faster the speed of installation.

Connection strength of sheet piles

Laboratory tests were carried out to examine the strength of sheet piles at their connections (Fig. 12). Three concrete panels (left, middle, and right) were used. The three panels were fixed together using the method described above, where the steel I-beam and tube were used as the reinforcement for the grouting. The I-beam had its cross-section dimensions as follows: flange length equal to 80 mm, web width equal to 40 mm, and wall thickness equal to 4 mm. The steel tube had its cross-section dimensions as follows: length equal to 80 mm, width equal to 60 mm, wall thickness equal to 4 mm, and the opening gap equal to 10 mm. Each of the three concrete panels was 0.30 m long, 0.15 m wide, and 0.30 m thick.

The middle panel was placed 0.05 m above the left and right panels. The connection between the middle panel and each of the other two panels was 0.25 m high and 0.30 m

wide. The test was carried out on the 28th day after grouting of the two connections of the three panels. A first steel plate was placed above the middle panel. A second steel plate on the support platform was placed beneath the left and right panels. An axial load was applied to the first steel plate on the upper surface of the middle panel and was then transferred to the second steel plate with the left and right panels.

Three failure tests were conducted. The axial load for the failure at the two connections of the three panels was about 316 kN. The failures were found within the panel concrete for the steel I-beam or tube. The grouted connections between the left panel and the middle panel or between the middle panel and the right panel did not fail. The average shear strength of the panel connections for three tests was equal to 2.1 MPa (i.e., $316 \text{ kN}/(0.25 \text{ m} \times 0.30 \text{ m})/2$).

Static load tests of individual sheet piles

Static pile load tests were carried out on two individual concrete sheet piles at Guang-nan reservoir. The two sheet piles were jetted into ground at a site near the mouth of the Yellow River. The two sheet piles were 12 m long. Their cross-sections were rectangular and were 1 m wide and 0.3 m thick. The two piles were driven into the soil stratum completely by jetting. The disturbed soil zone adjacent to the first sheet pile was strengthened by grouting. The grouting was not applied to the second sheet pile. The two piles were completely buried in soil strata. The static loading tests were conducted on the 60th day after pile installation. Strain gauges were also installed on the steel reinforcements of the two sheet piles at different depths.

The soils had the following seven strata: silty clay, silt, silty clay, silt, clay, silt, and mud clay. The groundwater table was 3.5 m below the ground surface. The soil physical

and mechanical properties are shown in Table 3. A conventional cone penetration test (CPT) was conducted at the site. The CPT tip and friction resistances with depths are shown in Figs. 13 and 14, respectively. The CPT data shows that the sheet pile toe bearing soil stratum was a 2 m thick silt stratum with a CPT tip resistance of 4 MPa. This soil stratum was underlain by a weak mud clay with a CPT tip resistance of 1 MPa.

Figures 15 and 16 show the axial load distributions along the first grouted sheet pile and the second ungrouted sheet pile at different applied loading levels. Figures 17 and 18 show the settlements of the first grouted sheet pile head and the second ungrouted sheet pile head as the applied loading increased.

The results shown in Figs. 14–18 prompt the following observations:

- The first sheet pile had a limiting bearing capacity of 540 kN, the second 400 kN.
- The second pile had zero shaft resistance at the limiting load application of 400 kN. The limiting bearing capacity of 400 kN was therefore mainly due to the toe resistance, which indicates the soil capacity at the pile toe was 1.3 MPa.
- The grout applied to the disturbed soil zone for the first sheet pile evidently increased the skin and toe resistance of the surrounding soils.
- At the pile head settlement of 40 mm, the first and the second piles had bearing capacity values of 480 and 320 kN, respectively, which indicates that the grouting caused a net increase in the pile capacity of 50% (i.e., $(480-320)/320$).

It is therefore evident (i) that the ungrouted sheet pile had adequate bearing capacity; and (ii) that the grouting of disturbed soils improved the pile bearing capacity.

Trial pit adjacent to concrete sheet pile

To examine the disturbed soil zone adjacent to the concrete sheet pile, a trial pit as shown in Fig. 19 was dug adjacent to an existing concrete sheet pile installed by the new jetting method at the 5th Channel in Yellow River Mouth. Figure 20 shows the soil condition at the bottom of the trial pit. The trial pit was 600 mm wide, 600 mm long, and 600 mm deep. The disturbed soil zone adjacent to the concrete pile was not easily distinguishable from the surrounding soil and appeared to be less than 20 mm wide.

Applications

Breakwater

A breakwater was built in July 1998 at a coastal site in northern China on the shore of the Bohai Sea (Fig. 21) near a former mouth of the Yellow River. The breakwater was constructed using the grouted jetted precast sheet piling method, and the aim of the experiment was to determine whether this breakwater could resist heavy seabed erosion.

In recent years the sea has encroached severely on the southern shores of the Bohai Sea. The shore and seabed at the breakwater site were originally formed as a result of the deposition of sediment at one of the mouths of the Yellow River. In 1976 this particular mouth dried up, and the Yellow

Fig. 22. Details of the breakwater. (a) Cross-section of the breakwater and foundation soil. (b) T-shaped pile connected with three sheet piles. (c) Details of I-beams and tubes for T-shaped pile.

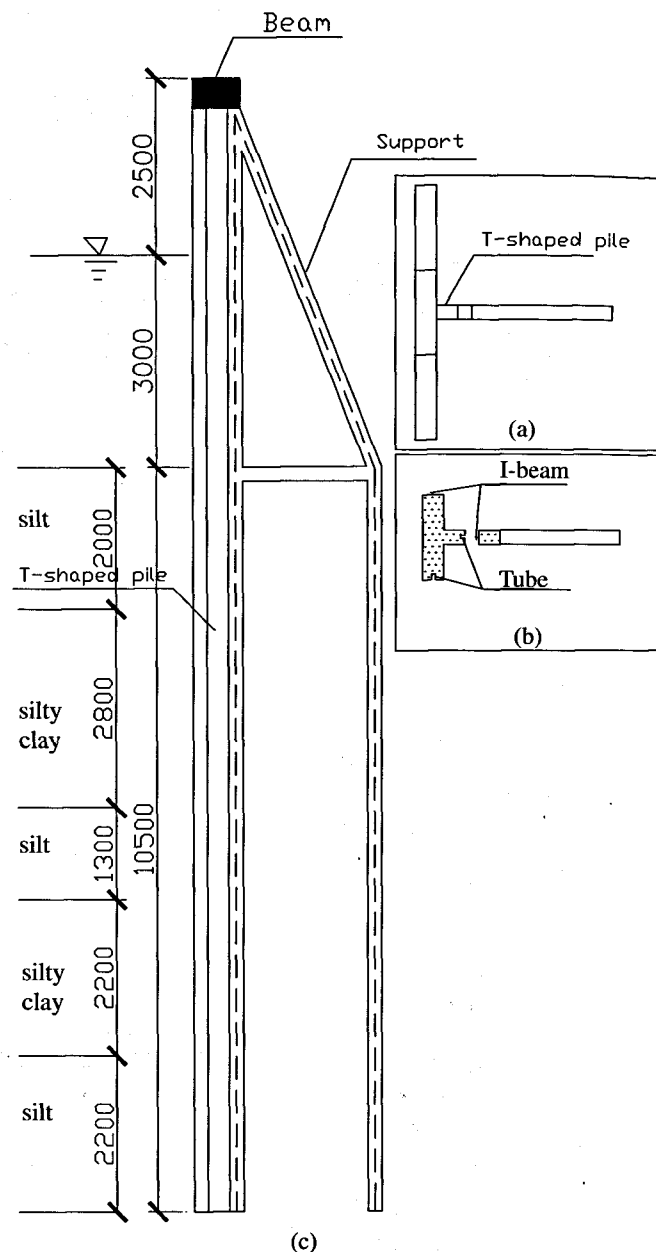

River began to discharge its main flow at Qing-shui-gou. As a result, sediment deposition at the breakwater site came to an end. A few years later the Bohai Sea began to encroach on the site, drowning a considerable land area. A long protective embankment to prevent further encroachment was built along the new shoreline. However, continued erosion has lowered the seabed and weakened the embankment foundation soils.

The breakwater was located 30 m outside the main embankment. Figure 22 shows details of the sheet pile design and construction. In addition to the concrete sheet piles, concrete T-shaped piles were also used. Each pile was 1.2 m wide, 0.3 m thick, and 16.0 m long. At the top of the break-

Fig. 23. Water discharge control lock at Yellow River Mouth (photo taken in 2003).

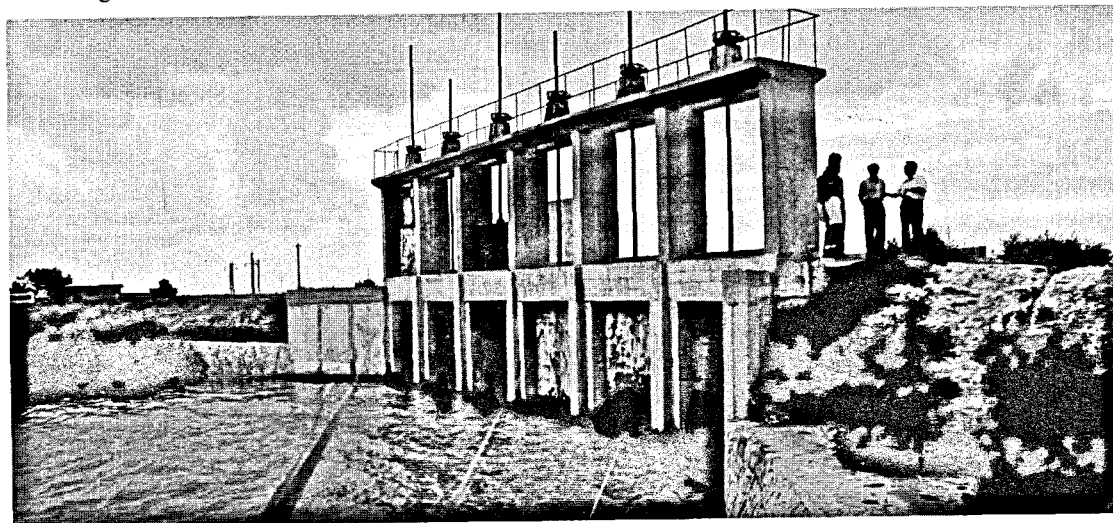

water, steel reinforcements 0.3 m high were preset and left for later construction of pile cap beams by the cast-in-place method. T-shaped piles were added for lateral support behind the front wall of the breakwater at 6.0 m intervals. As shown in Fig. 22a, each T-shaped pile was connected with two sheet piles parallel to the front wall and a third sheet pile perpendicular to the front wall. As shown in Fig. 22b, each T-shaped pile was connected with the other three sheet piles by one I-beam and two rectangular tubes. The third sheet pile was 2 m wide, 0.3 m thick, and 16 m long.

Immediately after the breakwater was finished the piles were immersed in 3 m of seawater, and their bases were buried in 10.5 m of soil. Their tops protruded 2.5 m above the water. The reinforced concrete capping was 0.4 m high and 0.3 m wide. As shown in Fig. 22c, the foundation soils were mainly fine soils. Their physical and mechanical properties are similar to those given in Tables 1 and 3. Between 1998 and 2002 the seabed in front of the breakwater had eroded to a depth of about 1 m by wave action. At present, the breakwater is still standing.

Water discharge control lock

A water discharge control lock was also built at the main mouth of the Yellow River (Fig. 23). The lock was constructed in 1997 with the grouted jetted precast concrete piling method. The precast concrete sheet piles had a total length of 11.0 m. As shown in Figs. 23 and 24, three types of sheet piles were designed and used: lateral sheet piles, middle sheet piles, and lock sheet piles. The lock sheet pile is open in its upper portion, where a gate plate is installed for controlling the water flow through the control lock.

The thickness of the sheet piles buried in soil was 0.65 m. The piles had their lower 6.0 m buried in the soils. The soils were mainly clay and silt. The main bearing soil was silt (Fig. 24), and the fluctuation of the river water level was about 2 m. Since 1997, the lock has been functioning well.

Wastewater treatment pools

The piling method was also used to construct several wastewater treatment pools in 2000 near Wang-jia-gang Vil-

lage. Each pool was 3.5 m deep, 15 m wide, and 56 m long (Fig. 25), and was constructed by excavation. The excavated pit depth was 4 m. The soils were mainly silt and silty clay.

Before excavation, precast sheet piles were installed by jetting and then grouted together in-place to form impervious diaphragm walls. Each individual sheet pile was 7.5 m long, 1.20 m wide, and 0.25 m thick. After grouting, the capping beams of the walls were constructed by the cast-in-place method. The sheet piles had steel bars 0.2 m long on the pile head. These vertical bars were further connected with the horizontal steel bars for the wall capping beams. After completion of the excavation, a geotextile and a rock fill layer were placed on the excavated base of the pool. An impervious concrete plate base was then constructed by cast-in-place with steel reinforcements. So far, the pools have been functioning well.

Summary and conclusions

Jetting for pile driving has many advantages. In particular, it does no harm to the environment and is an efficient technique. However, conventional jetting methods produce a large disturbed and liquefied soil zone surrounding the pile, which can significantly reduce pile bearing capacity in ways difficult to predict.

In this paper, we have presented an innovative pile jetting method that minimizes the extent of the disturbed zone adjacent to the pile and provides greater control of the piling process. The new technique generates uniform streams of highly pressurized water from many small nozzle holes at the pile toe, minimizing disturbance to the surrounding soils and conserving their shear strength. We have also presented an innovative grouting method to lock and seal together sheet piles to form continuous pile groups and (or) diaphragm walls. This ensures the quality of the connection grouting for adjacent sheet piles.

We have presented four experiments and their results. They are used to demonstrate (i) the high jetting efficiency, (ii) the high grouting strength for sheet pile connection, (iii) the high pile bearing capacities with and without grouting of disturbed soil zone adjacent to the pile, and (iv) the

Fig. 24. Details of the sheet pile design for the water discharge control lock.

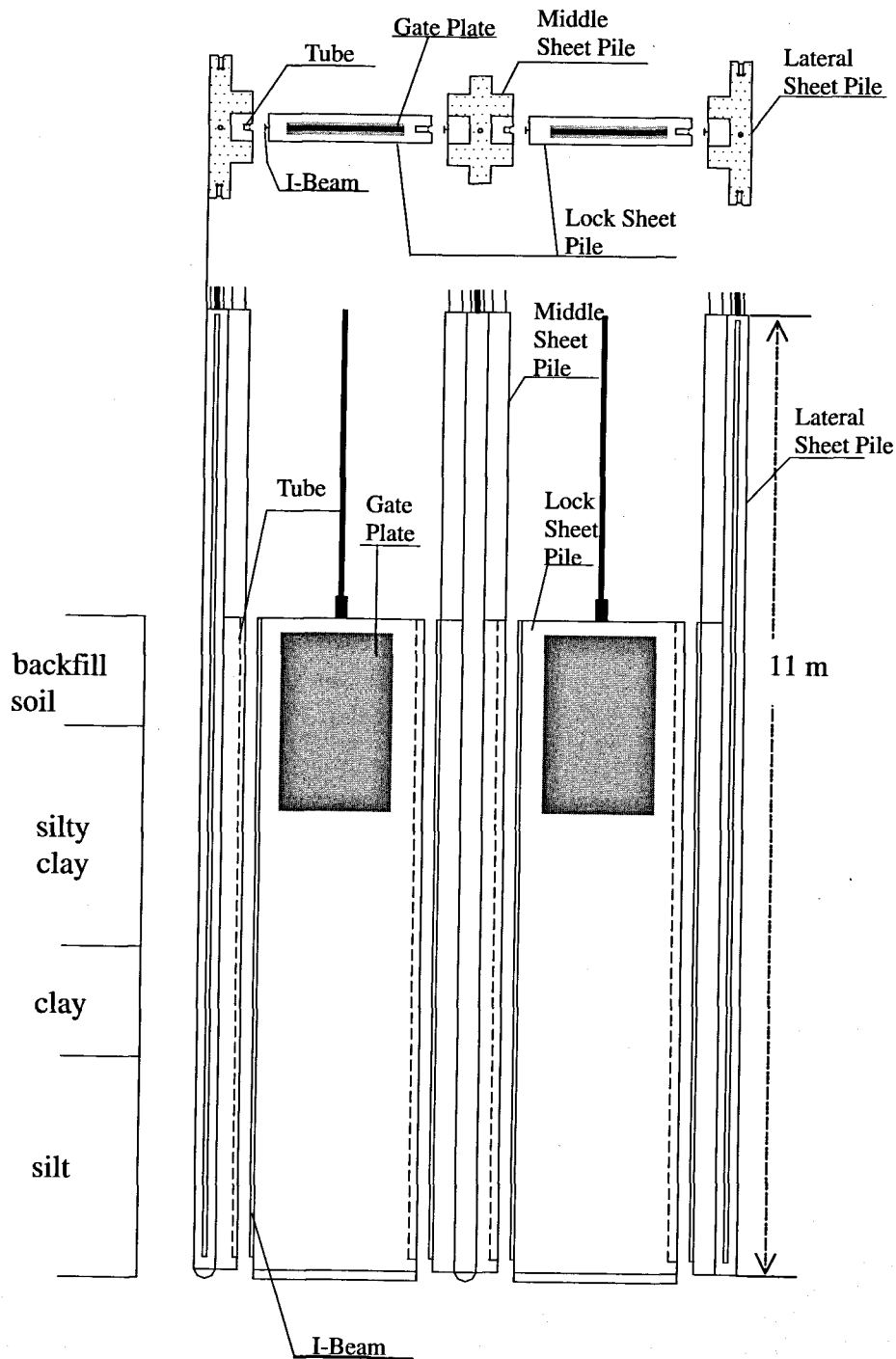

narrow disturbed soil zone, respectively. We have also presented some practical values of the design parameters for jetting and grouting. These practical values were obtained from trials near the mouth of the Yellow River. They are useful for further applications in other similar ground regions.

Finally, we have described three practical applications of the proposed jetted grouted precast concrete sheet piling method in building projects in sites near the mouth of the

Yellow River. These applications were selected from more than 20 such projects in the region over the past 10 years, including seawalls, breakwaters, bridges, wharfs or piers, bridge piles, culvert piles, diaphragm walls for wastewater pools, water flow control locks, and water flow discharge channels. We have also shown that the proposed method can be used in a range of civil engineering projects in coastal regions where the main soil types are sediments and the water is shallow.

Fig. 25. Grouted jetted precast concrete sheet piles for the diaphragm walls of wastewater treatment pools (photo taken in 1999).

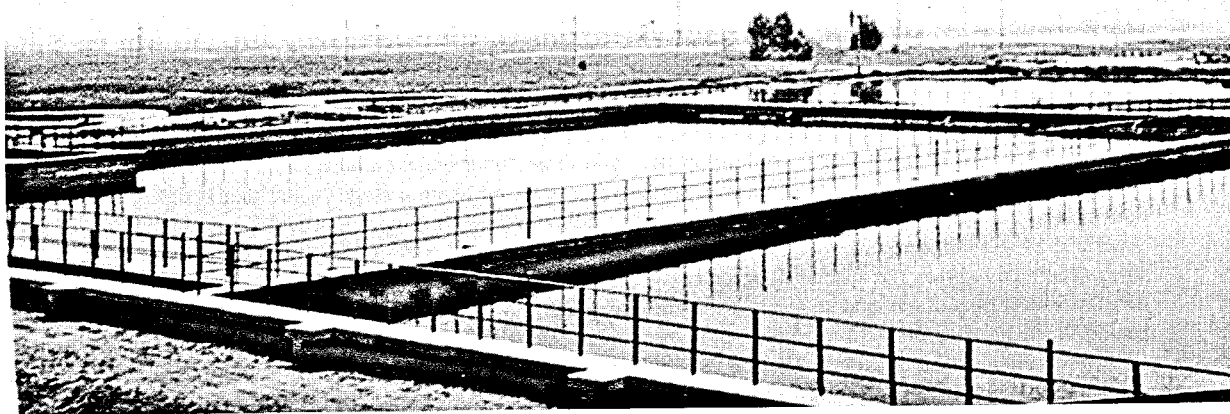

Acknowledgements

The authors would like to acknowledge the financial support they have received for this project from Hong Kong's Research Grants Council, the National Science Foundation of China (Project No. 40472137), and Key Scientific and Technological Projects of Shandong Province (Project No. 2004GG3204003). The authors would also like to thank Professor Arun J. Valsangkar, the Associate Editor, and the two reviewers for their comments on an early draft of this paper.

References

- Hameed, R.A., Gunaratne, M., Putcha, S., Kuo, C., and Johnson, S. 2000. Lateral load behavior of jetted piles. *Geotechnical Testing Journal*, ASTM, 23(3): 358–368.
- Li, S., Yue, Z.Q., Tham, L.G., Lee, C.F., and Yan, S.W. 2005a. Slope failure in underconsolidated soft soils during the development of a port in Tianjin, China. Part 1: Field investigation. *Canadian Geotechnical Journal*, 42(1): 147–165.
- Li, S., Yue, Z.Q., Tham, L.G., Lee, C.F., and Yan, S.W. 2005b. Slope failure in underconsolidated soft soils during the development of a port in Tianjin, China. Part 2: Analytical study. *Canadian Geotechnical Journal*, 42(1): 166–183.
- Shestopal, A.O. 1959. Jetting of pipes, piles, and sheet piles. Hydroproject Institute. Moscow, USSR. [In Russian.]
- Tsinker, G.P. 1977. Performance of jetted anchor piles with widening. *Journal of Geotechnical Engineering Division, ASCE*, 103(GT3): 213–226.
- Tsinker, G.P. 1988. Pile jetting. *Journal of Geotechnical Engineering, ASCE*, 114(3): 326–334.