



**This electronic thesis or dissertation has been  
downloaded from Explore Bristol Research,  
<http://research-information.bristol.ac.uk>**

*Author:*

**Pickard, Laura Rhian**

*Title:*

**Towards Efficient Composites Manufacture Through In-Process Monitoring and Knowledge Management**

**General rights**

Access to the thesis is subject to the Creative Commons Attribution - NonCommercial-No Derivatives 4.0 International Public License. A copy of this may be found at <https://creativecommons.org/licenses/by-nc-nd/4.0/legalcode>. This license sets out your rights and the restrictions that apply to your access to the thesis so it is important you read this before proceeding.

**Take down policy**

Some pages of this thesis may have been removed for copyright restrictions prior to having it been deposited in Explore Bristol Research. However, if you have discovered material within the thesis that you consider to be unlawful e.g. breaches of copyright (either yours or that of a third party) or any other law, including but not limited to those relating to patent, trademark, confidentiality, data protection, obscenity, defamation, libel, then please contact [collections-metadata@bristol.ac.uk](mailto:collections-metadata@bristol.ac.uk) and include the following information in your message:

- Your contact details
- Bibliographic details for the item, including a URL
- An outline nature of the complaint

Your claim will be investigated and, where appropriate, the item in question will be removed from public view as soon as possible.



**This electronic thesis or dissertation has been  
downloaded from Explore Bristol Research,  
<http://research-information.bristol.ac.uk>**

*Author:*

**Pickard, Laura Rhian**

*Title:*

**Towards Efficient Composites Manufacture Through In-Process Monitoring and Knowledge Management**

**General rights**

Access to the thesis is subject to the Creative Commons Attribution - NonCommercial-No Derivatives 4.0 International Public License. A copy of this may be found at <https://creativecommons.org/licenses/by-nc-nd/4.0/legalcode>. This license sets out your rights and the restrictions that apply to your access to the thesis so it is important you read this before proceeding.

**Take down policy**

Some pages of this thesis may have been removed for copyright restrictions prior to having it been deposited in Explore Bristol Research. However, if you have discovered material within the thesis that you consider to be unlawful e.g. breaches of copyright (either yours or that of a third party) or any other law, including but not limited to those relating to patent, trademark, confidentiality, data protection, obscenity, defamation, libel, then please contact [collections-metadata@bristol.ac.uk](mailto:collections-metadata@bristol.ac.uk) and include the following information in your message:

- Your contact details
- Bibliographic details for the item, including a URL
- An outline nature of the complaint

Your claim will be investigated and, where appropriate, the item in question will be removed from public view as soon as possible.

# *Towards Efficient Composites Manufacture Through In-Process Monitoring and Knowledge Management*

Laura Rhian Pickard

A dissertation submitted to the University of Bristol in accordance with the requirements for award of the degree of Doctor of Engineering in the Faculty of Engineering.

October 2018

72069 words





# *Abstract*

This thesis covers topics ranging from cure cycle optimisation to knowledge management, in-process XCT Scanning to lessons learned, dielectric monitoring to procurement of large equipment. Tying these seemingly disparate themes together is a simple aim- to contribute to an improvement in the efficiency composites manufacturing, through better understanding of both the physical and managerial aspects of such.

Tracking the volume of defects during cure of a sample with a newly developed method for in-process XCT Scanning- using industrial equipment only- contributes to our understanding of the level of accuracy required in layup. Using dielectric monitoring to optimise, follow and control the cure cycle used can result in lower energy- or faster- cure without compromising on the final product. And understanding of how knowledge transfer differs in industry and academia, and the business processes required to make use of these new technologies, can help to bring these benefits to companies, particularly the small and medium sized enterprises (SMEs) who often lack a specialised research and development department, but can benefit from flexibility far beyond that of a corporate behemoth.

Knowledge transfer studies, carried out with companies and academic institutions in the UK and Canada, provide an understanding of how these organisations learn. A combination of simple but illuminating opinion questions, knowledge network analysis and a new tweak on the classic skills matrix- with a check that helps to balance out individual bias; these studies themselves have proved useful to many of the participating organisations.

With this in mind, a combination of original, practical research and reference to that which has been done before was used to produce a demonstration of knowledge transfer aimed at SMEs, taking that which had previously been almost exclusively in the academic realm and aiming squarely at the industrial sector. This tool, showing the potential benefits (and issues) of using dielectric and DC cure monitoring in industrial processes was supplied to volunteer companies for their feedback. Combined with the real, practical demonstration of using this technology with industrial equipment to achieve more efficient cure of a composite part of varying thickness, a step forward has been made on the journey from laboratory to factory.



# *Acknowledgements*

This work was supported by the Engineering and Physical Sciences Research Council through the EPSRC Industrial Doctorate Centre in Composites Manufacture [EP/K50323X/1] and by the National Composites Centre, which hosted the work as the EngD sponsoring organisation. Equipment purchased under the EPSRC Atoms to Applications grant [EP/K035746/1] was vital to the work.

The author was registered with the University of Bristol and benefited from interacting with many people from the Advanced Composites Collaboration for Innovation and Science group. This work has also involved collaboration with members of the Language Of Collaborative Manufacturing team from the Universities of Bath and Bristol and a very useful two month secondment with the Composites Research Network, University of British Columbia.

I would also like to acknowledge the organisations who participated in the Knowledge Transfer Studies, and to thank the individuals at each who helped to arrange my visits and chased up questionnaires. I promised to anonymise the results, so sadly cannot name you here. Thanks to Composites UK, NCC and CRN for the contacts.

This project would not have been possible without the guidance of my four supervisors, Professor Ivana Partridge, Professor Kevin Potter, Dr Dan Kells and Paul Shakspeare. Thank you very much for all the help and advice, particularly for your patience during the writing up.

Thank you to Dr George Maistros of Advise-DETA, Dr Nikos Pantelelis of Synthesites and the team at ASC for assistance in setting up the sensor systems with the autoclave and interpreting the results. There are too many individuals at NCC and the University of Bristol to name everyone, but I wish to particularly thank Andy Kinsman and Lucy Neaves for all the hard work involved in obtaining the necessary equipment and Dr Julie Etches for all the health and safety advice. Thank you to Dr Anastasia Koutsomitopoulou, Dr James Kratz and Katie Smith for working with me, and to Miles Holt for his determination to get to the bottom of the DMA problem. Special thanks to Hannah Watkins for a huge amount of data entry and to Logan Wang for his work on the videos. Thank you to Dr Giuseppe Dell'Anno for his enthusiasm regarding my knowledge transfer work. At CRN, special thanks to Janna Fabris and Professor Anoush Poursartip for sharing their work and to Suzana Topic and Bryn Crawford for arranging my visit to Okanagen.

Particular thanks to Jo Brooks and Maria Aviles for all your hard work over the past few years.

Most importantly, thank you to my parents for your kindness, patience and endless supply of tea.



# *Author's Declaration*

I declare that the work in this dissertation was carried out in accordance with the requirements of the University's *Regulations and Code of Practice for Research Degree Programmes* and that it has not been submitted for any other academic award. Except where indicated by specific reference in the text, the work is the candidate's own work. Work done in collaboration with, or with the assistance of, others, is indicated as such. Any views expressed in the dissertation are those of the author.

SIGNED: ..... DATE:.....



# Table of Contents

<b>1</b>	<b>Introduction</b>	<b>1</b>
<b>1.1</b>	<b>Scope of Work</b>	<b>1</b>
<b>1.2</b>	<b>Problem Statements</b>	<b>2</b>
1.2.1	Knowledge transfer in academia and composites SMEs	2
1.2.2	Measurement of defect and feature evolution during cure	2
1.2.3	Cure monitoring for optimisation, active process control and quality assurance	3
1.2.4	Knowledge transfer resource for technology transfer from academia to industry	3
<b>1.3</b>	<b>Thesis Structure</b>	<b>4</b>
<b>1.4</b>	<b>Advanced Composites</b>	<b>5</b>
<b>1.5</b>	<b>Uses of Composite Parts</b>	<b>6</b>
<b>1.6</b>	<b>Manufacturing</b>	<b>7</b>
1.6.1	Route 1	8
1.6.2	Route 2	8
1.6.3	Cure	10
1.6.3.1	Vacuum bagging	10
1.6.3.2	Ovens and autoclaves	11
<b>1.7</b>	<b>Efficiency</b>	<b>12</b>
1.7.1	Energy efficient cure	12
1.7.1.1	Dielectric monitoring	13
1.7.1.2	Comparative measurements	15
1.7.2	Reducing scrap rate	17
1.7.2.1	Dielectric monitoring	17
1.7.2.2	Defect tolerances	18
<b>1.8</b>	<b>Knowledge management</b>	<b>19</b>
1.8.1	Knowledge Transfer in a Business	20

1.8.1.1	From Data to Wisdom	20
1.8.1.2	Information Management	21
1.8.1.3	People (with) Skills	21
1.8.1.4	Knowledge Networks	21
1.8.2	The Composites Competency Crisis	22
1.8.2.1	Academia to Industry	22
<b>1.9</b>	<b>The National Composites Centre</b>	<b>23</b>
<b>1.10</b>	<b>The EngD in Composites Manufacture</b>	<b>24</b>
<b>2</b>	<b>Literature Review</b>	<b>25</b>
<b>2.1</b>	<b>Scope</b>	<b>25</b>
<b>2.2</b>	<b>The Cure Process</b>	<b>26</b>
2.2.1	Time-Temperature Transformation diagram	26
2.2.2	Cure Kinetics	27
2.2.2.1	Isothermal degree of cure	28
2.2.2.2	Relating degree of cure to $T_g$	28
2.2.2.3	Model for Hexcel M21 resin	29
2.2.2.4	Model for Hexcel 8552 Resin	30
<b>2.3</b>	<b>In-Process Monitoring in Composites Manufacture</b>	<b>32</b>
<b>2.4</b>	<b>Dielectric Analysis (DEA) for Cure Monitoring</b>	<b>33</b>
2.4.1	Sensor technologies	34
2.4.1.1	Microwave cavity	34
2.4.1.2	Parallel plate electrodes	34
2.4.1.3	Interdigitated sensors	36
2.4.2	Resin Response to Sinusoidal Voltage	39
2.4.2.1	Electrode polarisation	40
2.4.2.2	Charge migration	41
2.4.2.3	Dipole relaxation	41
2.4.2.4	Interfacial polarisation	42



2.4.2.5	Combining the signals	43
2.4.3	Equivalent Circuit Analysis	44
2.4.4	Using $Z''$ to Track the Cure	45
2.4.4.1	Comparison to DSC results for isothermal cure	46
2.4.4.2	Determining degree of cure from IIM for dynamic cure	48
2.4.5	Technology transfer- can Dielectric Cure Monitoring be useful in Industry?	51
2.4.5.1	Waste reduction	52
2.4.5.2	Cure Optimisation	52
<b>2.5</b>	<b>Comparison to other cure monitoring techniques</b>	<b>53</b>
2.5.1	Direct Current (DC) resistance analysis	53
2.5.2	Thermocouples	54
2.5.3	Infrared Spectroscopy	54
2.5.4	Ultrasonic Cure Monitoring	55
<b>2.6</b>	<b>Microfocus X-Ray Computed Tomography for Defect Tracking</b>	<b>56</b>
2.6.1	XCT of Composites for Defect Evaluation	56
2.6.1.1	Measuring voids with XCT	57
2.6.2	XCT Studies of Changing Objects	59
2.6.2.1	Multiple Samples	59
2.6.2.2	4D XCT: Time resolved imaging	61
2.6.3	Industrial Applicability	64
2.6.3.1	Example: Tow gaps and ply drops in Automated Fibre Placement	64
2.6.3.2	Void growth	66
2.6.3.3	Defects can be unavoidable	67
<b>2.7</b>	<b>Knowledge Management</b>	<b>68</b>
2.7.1	All In The Mind?	68
2.7.1.1	Codifying knowledge	68
2.7.1.2	Interpersonal knowledge transfer	69
2.7.1.3	Codification or Personalisation?	71

2.7.2	Learning Organisations	72
2.7.3	Knowledge Audits	74
2.7.3.1	Questionnaires	75
2.7.3.2	Knowledge Network Analysis	76
2.7.4	Technology transfer and SMEs	81
2.7.5	Knowledge Matters	82
<b>2.8</b>	<b>Review Conclusions</b>	<b>84</b>
2.8.1	Knowledge transfer within and between academic and composites SMEs	84
2.8.2	Using micro X-ray CT scanning to track defects	85
2.8.3	Dielectric analysis for monitoring degree of cure	86
2.8.4	Knowledge Transfer Resource for Dielectric Cure Monitoring	87
<b>3</b>	<b><i>Knowledge Transfer in Academia and Composites SMEs</i></b>	<b>88</b>
<b>3.1</b>	<b>Rationale</b>	<b>88</b>
<b>3.2</b>	<b>Knowledge Transfer Studies</b>	<b>89</b>
3.2.1	Aims	89
3.2.2	Value to participating company	90
3.2.3	Development of questionnaire	90
3.2.3.1	First pilot study	90
3.2.3.2	Second pilot study	90
3.2.3.3	Final questionnaire	91
3.2.4	Participating Organisations	92
3.2.5	Knowledge Networks	93
3.2.5.1	Network Diagram construction	96
3.2.5.2	Limitations of this approach	98
<b>3.3</b>	<b>Key Findings: Knowledge Networks</b>	<b>99</b>
3.3.1	Case Study: Authority measurements in Company 8	99
3.3.1.1	Comparing HITS and Pagerank	99
3.3.2	Links between participating organisations	101

3.3.2.1	Communities and knowledge transfer between organisations _____	103
3.3.3	Case study: Before And After- Pilot study team _____	109
<b>3.4</b>	<b>Competence Matrices _____</b>	<b>112</b>
3.4.1	Case Study: Working Cultures at Company 6 _____	115
<b>3.5</b>	<b>Aggregate results of opinion-based questions _____</b>	<b>118</b>
3.5.1	Organisation categories _____	118
3.5.2	Participant demographics _____	119
3.5.3	Current State of Knowledge Transfer _____	120
3.5.3.1	Opinions on knowledge management in the organisations _____	120
3.5.3.2	Tasks during a project _____	122
3.5.3.3	Current knowledge transfer practices _____	123
3.5.4	Preferences for learning _____	124
3.5.4.1	Willingness to contribute to a wiki or forum _____	128
<b>3.6</b>	<b>Conclusions _____</b>	<b>130</b>
<b>4</b>	<b><i>In-Process XCT Scanning to Track Evolution of Prepreg Features During Cure.</i> _____</b>	<b>136</b>
<b>4.1</b>	<b>Abstract _____</b>	<b>136</b>
<b>4.2</b>	<b>Introduction _____</b>	<b>136</b>
4.2.1	Defect types _____	137
4.2.2	M21 cure _____	138
<b>4.3</b>	<b>Initial experiments _____</b>	<b>139</b>
4.3.1	Building work nearby _____	139
4.3.2	First proof of concept _____	140
4.3.2.1	Thermocouple positioning _____	141
4.3.2.2	Sample slippage _____	141
4.3.2.3	Shading correction _____	142
4.3.2.4	Scan settings _____	142
4.3.2.5	Sample positioning _____	142
<b>4.4</b>	<b>Experimental setup _____</b>	<b>143</b>

<b>4.5</b>	<b>Sample Geometries</b>	<b>146</b>
4.5.1	Tow Gap	146
4.5.2	Ply Drop	146
4.5.3	Glass fibre-M21 sample	147
<b>4.6</b>	<b>Method</b>	<b>148</b>
4.6.1	Temperature measurement baseline	148
4.6.2	X-ray CT settings	149
4.6.3	Void analysis	149
<b>4.7</b>	<b>Results</b>	<b>151</b>
4.7.1	Tow Gap	151
4.7.1.1	Comparison to theoretical resin behaviour	154
4.7.2	Ply Drop	156
4.7.2.1	Higher temperature runs, for comparison to tow gap samples.	157
4.7.2.2	Lower temperature runs- gelation during cool down.	158
4.7.3	Glass fibre samples	158
4.7.4	Comparing start, minimum and end total void volumes	159
4.7.5	Lateral fibre movement: Comparison of Tow Gap and Ply Drop defect evolution	160
4.7.5.1	Microscopy	161
<b>4.8</b>	<b>Conclusions and future work</b>	<b>162</b>
<b>5</b>	<b><i>Cure Cycle Optimisation and Control with Dielectric Monitoring</i></b>	<b>164</b>
<b>5.1</b>	<b>Abstract</b>	<b>164</b>
<b>5.2</b>	<b>Introduction</b>	<b>164</b>
5.2.1	Important Advisory	165
<b>5.3</b>	<b>Equipment</b>	<b>166</b>
5.3.1	Sensor systems	167
<b>5.4</b>	<b>Part and Materials</b>	<b>169</b>
<b>5.5</b>	<b>Method</b>	<b>172</b>
5.5.1	Test part construction	172

5.5.2	Cure	174
5.5.3	Use of Cure Monitoring Systems	175
5.5.4	DSC and DMA analysis	176
5.5.5	Cure simulations with Raven software.	177
<b>5.6</b>	<b>Cure Cycles and Active Process Control</b>	<b>178</b>
5.6.1	180°C cures	180
5.6.2	Low temperature cures	182
5.6.3	Sensor triggered cures	185
<b>5.7</b>	<b>Results</b>	<b>188</b>
5.7.1	Exotherm temperatures	188
5.7.2	Material properties	189
5.7.2.1	Sample extraction	189
5.7.2.2	Digital Scanning Calorimetry	189
5.7.2.3	Dynamic Mechanical Analysis	191
5.7.3	Technology Evaluation	193
5.7.3.1	Comparison of sensor results, laboratory tests and simulation	193
5.7.3.2	Practicalities and ease of use	216
5.7.4	Energy and Cost	219
<b>5.8</b>	<b>Conclusions and Future Work</b>	<b>221</b>
<b>6</b>	<b><i>Knowledge Transfer Resource for Dielectric Cure Monitoring</i></b>	<b>223</b>
<b>6.1</b>	<b>Exploring the Knowledge Transfer Resource</b>	<b>223</b>
<b>6.2</b>	<b>Principles and Structure</b>	<b>223</b>
6.2.1	Preferred Knowledge Transfer Methods Among Composites Workers	223
6.2.2	Structure Based on Industrial Requirements	224
6.2.3	Format of Knowledge Transfer Resource	226
<b>6.3</b>	<b>Development of Content</b>	<b>227</b>
<b>6.4</b>	<b>Conclusion</b>	<b>228</b>
<b>7</b>	<b><i>Discussion</i></b>	<b>229</b>

<b>7.1</b>	<b>Knowledge Transfer Studies</b>	<b>229</b>
7.1.1	Value of Knowledge Transfer Studies to participating organisations	230
7.1.2	Lack of links between Academia and Composites SMEs in this study	232
7.1.3	Knowledge Transfer in Academia and Industry	234
<b>7.2</b>	<b>In-Process micro-XCT Scanning for Defect Tracking</b>	<b>236</b>
7.2.1	Demonstration of In-Process micro-XCT during composite cure	236
7.2.2	Evolution of studied defects during cure	237
<b>7.3</b>	<b>Dielectric Cure Monitoring for Process Optimisation</b>	<b>238</b>
7.3.1	Active Process Control and Quality Assurance	238
7.3.2	Comparison of dielectric analysis results to laboratory tests	240
7.3.3	Discrepancy between simulation and other measures	241
<b>7.4</b>	<b>Knowledge transfer resource for dielectric cure monitoring</b>	<b>242</b>
<b>7.5</b>	<b>Future work</b>	<b>244</b>
<b>8</b>	<b>Conclusions</b>	<b>248</b>
	<b>References</b>	<b>251</b>
	<b>Appendix 1: Knowledge Transfer Study Questionnaire</b>	<b>270</b>
	<b>Appendix 2: Steps in Void analysis macro</b>	<b>274</b>
	<b>Appendix 3: DSC Certificate of Calibration</b>	<b>275</b>
	<b>Appendix 4: DMA Certificate of Calibration 1</b>	<b>276</b>
	<b>Appendix 5: DMA Certificate of Calibration 2</b>	<b>277</b>
	<b>Appendix 6: Knowledge Transfer Resource Slides</b>	<b>278</b>
	<b>Appendix 7: Knowledge in Practice Document for Dielectric (and DC) Cure and Resin Arrival Monitoring And Control Using Electrode Based Sensors</b>	<b>286</b>
	<b>Appendix 8: List of Electronic Materials</b>	<b>318</b>

## *Table of Figures*

Figure 1.1: Making a composite part. ....	5
Figure 1.2: UK Composite Market according to Composites Leadership Forum. Reproduced from [2]	7
Figure 1.3: The Schuler Press at the National Composites Centre. Image from National Composites Centre.[5] .....	8
Figure 1.4: Hand layup of prepreg. Image from National Composites Centre.[5] .....	9
Figure 1.5: Automated Fibre Placement Robots on 7m linear axis. Each head can lay up 8x 6.35mm width tows [8]. Images from National Composites Centre.[5] .....	9
Figure 1.6: Bagging diagram for a composite part.....	11
Figure 1.7: Autoclave, 11.2m long x 3.55m diameter [8]. Image from National Composites Centre.[5] .....	12
Figure 1.8: Hexcel's recommended cure cycle for 8552. Reproduced from Hexcel 8552 Data Sheet [15]. .....	13
Figure 1.9: Charged particle response to alternating current .....	14
Figure 1.10: Dielectric sensors for tool mounting (left, ~1cm diameter) and internal use (~1cm width strip).....	14
Figure 1.11: Example of $T_g$ measurement using DMA. ....	16
Figure 1.12: Automated Fibre Placement type tapes placed on a curved hemisphere. Reproduced from [26]. .....	18
Figure 1.13: Micro X-ray Computed Tomography Scanning.....	19
Figure 1.14: A Knowledge Network. Diagram generated using UCINet [30]. .....	22
Figure 1.15: The National Composites Centre facilitates technology transfer from academia to industry. [5].....	23
Figure 1.16: Non-Artist's Impression of the EngD.....	24
Figure 2.1: Time-temperature transformation diagram. Reproduced from [35] .....	26
Figure 2.2: Comparison of experimental and theoretical models for cure of M21. Reproduced from [43] .....	30

Figure 2.3: NCAMP model for 8552 resin, with parameters for DiBenedetto equation. Reproduced from [23] .....	31
Figure 2.4: (a) Parallel plate electrodes, with electric field through the whole sample, and (b) interdigitated electrode with fringing electric field. Reproduced from [46]. .....	34
Figure 2.5: Parallel plate sensors for Resin Transfer Moulding. Reproduced from [74].....	35
Figure 2.6: Flexible electrode. Figure 2.7: Parallel plate and interdigitated electrodes. Reproduced from [77] .....	36
Figure 2.8: Penetration of fringing field into test material. Reproduced from [17] .....	36
Figure 2.9: A sensor designed for mounting in a tool surface.    Figure 2.10: A resin cell in use.....	37
Figure 2.11: Flexible interdigitated electrode (Lacomtech, Daejeon, Korea). Reproduced from [91] .	38
Figure 2.12: Comparison of standard and microscale sensors (smallest scale is mm). Reproduced from [93] .....	39
Figure 2.13: Relative permittivity and dielectric loss during the cure of an epoxy resin. Graphs reproduced from [104]. Titles and annotations, showing the clearest feature of each contributing factor, added here. ....	43
Figure 2.14: Equivalent circuit representation of electrodes and resin in a system with a single static dipole relaxation and no interfacial polarisation. Based on [88].....	44
Figure 2.15: Illustration of $\log Z'$ and $\log Z''$ versus $\log$ frequency, 3 zones of the cure. Reproduced from [88]. ....	45
Figure 2.16: Plot of $\log Z''$ as a function of frequency during isothermal cure of RTM6 resin at 140 °C, reproduced from [101] . ....	46
Figure 2.17: Plot of $\log Z''$ peak value against cure time, isothermal cure of RTM6 at 140 °C, compared to degree of cure (fractional conversion) measured by DSC. Reproduced from [101]. ....	46
Figure 2.18: Evolution of $\log Z''$ peak and degree of cure (conversion) scaled relative to the minimum and maximum for isothermal cure of RTM6. Reproduced from [101] .....	47
Figure 2.19: Normalised $\log IIM$ (grey) and degree of cure (black) vs cure time. Reproduced from [20] .....	47
Figure 2.20: $\log IIM$ and degree of cure (fractional conversion) for dynamic cure of RTM6 at 0.25°C/min. Reproduced from [105]. ....	48



Figure 2.21: Comparison of DSC heat flux curves with derivative of IIM. Reproduced from [105].	48
Figure 2.22: Comparison of DSC and IIM measurements for dynamic cures of RTM6. Reproduced from [105].	49
Figure 2.23: DSC and IIM derived rates of reaction for cure of RTM6 at 0.6°C/min. Reproduced from [94].	50
Figure 2.24: Comparison of DSC and simplified IIM derived degree of cure. Reproduced from [89].	51
Figure 2.25: Degree of cure vs time as measured by DEA and FTIR spectroscopy. Reproduced from [67].	55
Figure 2.26: Cone beam XCT with a flat panel detector. Reproduced from [134].	56
Figure 2.27: Surface determination for scan of a carbon fibre-epoxy sample. Reproduced from [139]. Annotations added.	57
Figure 2.28: Influence of threshold on porosity. The left picture is a slice from a CT volume. The three pictures on the right show the voids measured at different thresholds. Reproduced from [142].	58
Figure 2.29: Thresholds (Th1-5) on grey value histogram for a composite part. Reproduced from [142].	59
Figure 2.30: Porosity during prepreg impregnation, multiple samples. Reproduced from [27].	60
Figure 2.31: Porosity, viscosity and temperature over time, recommended cure cycle. Reproduced from [28].	60
Figure 2.32: Porosity, viscosity and temperature over time, optimised cure cycle. Reproduced from [28].	61
Figure 2.33: Strategies for time resolved XCT of a changing single sample. Reproduced from [136].	62
Figure 2.34: XCT slices showing a water bubble (diameter ~4.2mm) in epoxy resin (without fibre reinforcement) during cure. Reproduced from [150].	64
Figure 2.35: Tow steering in Automated Fibre Placement. Reproduced from [4].	64
Figure 2.36: Where AFP tapes are laid up around a corner, either the radius becomes too tight, causing wrinkling (a), or a gap is necessary (b). Reproduced from [154].	64
Figure 2.37: AFP tow cuts at boundaries create gaps and overlaps. Reproduced from [153].	65
Figure 2.38: Comparison of experimental result (left) and end state of simulation. Reproduced from [151].	66

Figure 2.39: Projected green laser lines show the acceptable positional limits for tapes being laid down by an AFP machine. AFP tape is usually ~6mm wide. Reproduced from [4]. ..... 67

Figure 2.40: Moteleb and Woodman’s Knowledge Management Modelling Matrix. Reproduced from [176]..... 71

Figure 2.41: An example of a sociogram- a sociometric star. Reproduced from [166] ..... 76

Figure 2.42: Sociograms of an expert consultant group, reproduced from [191]. Names are disguised. .... 77

Figure 2.43: Ties between wineries and Government Support Institutions in Mendoza and San Juan, reproduced from [206]. Data based on interviews with a range of staff members carried out in 2004-05. [206] ..... 81

Figure 3.1: Passive to active scale of learning. Reproduced from [31]...... 94

Figure.3.2: Example of a push network, from second pilot study. For simplicity, only participants are shown..... 94

Figure 3.3: A network diagram with key people who link subgroups highlighted. Taken from the second pilot study (pull network). For simplicity, only participants are shown. .... 95

Figure 3.4: Illustration of calculation of Authority,  $a_p$ , and Hub,  $h_p$ , for page  $p$ , reproduced from [195] ..... 96

Figure 3.5: Illustration of a simplified PageRank calculation, reproduced from [194] ..... 97

Figure 3.6: Illustration of a Rank Sink, reproduced from [194] ..... 98

Figure 3.7: Push and pull networks for Company 8, with nodes sized by Authority, Hubs and Weighted PageRank (no damping). Nodes highlighted in green represent known senior figures at the company. Person PN03 is highlighted in red, person PN11 in yellow and person NN01 in blue. Non-participants labelled in red. .... 100

Figure 3.8: Pull network for all participants. Nodes sized by weighted PageRank with no damping. .... 101

Figure 3.9: Push network for all participants. Nodes sized by PageRank with no damping. .... 102

Figure 3.10: Pull network from the second pilot study coloured by modularity class, with nodes sized by PageRank with no damping. Only participants are shown. .... 103

Figure 3.11: Pull network of all organisations by modularity class (clique). Note that academic group 2 and company 2 register as a single clique and that the groups within the research institution and

academic group 1 do not line up with the capability teams in the RI or the universities within the academic group, with academics combined with RI staff in some cliques. Nodes sized by PageRank with no damping ..... 107

Figure 3.12: Push network of all organisations by modularity class (clique). Again academic group 2 and company 2 register as a single clique. Here the groups within the research institution and academic group 1 combine differently to the pull network. Nodes sized by PageRank with no damping. .... 108

Figure 3.13: Pilot group push network, coloured by modularity class and node size by pagerank with no damping. Non-participants labelled in red. .... 109

Figure 3.14: Pilot group pull network, coloured by modularity class and node size by pagerank with no damping. Non-participants labelled in red. .... 109

Figure 3.15: Same team during final study, push network. Coloured by modularity class from the pilot study, with those who were not in the pilot study in blue. Nodes sized by weighted pagerank with no damping. Non-participants are labelled in red. .... 110

Figure 3.16: Same team during the final study, push network. Coloured by modularity class from this round. Nodes sized by weighted pagerank with no damping. Non-participants are labelled in red. .... 110

Figure 3.17: Same team during final study, pull network. Coloured by modularity class from the pilot study, with those who were not in the pilot study in blue. Nodes sized by weighted pagerank with no damping. Non-participants are labelled in red. .... 111

Figure 3.18: Same team during the final study, pull network. Coloured by modularity class from this round. Nodes sized by weighted pagerank with no damping. Non-participants are labelled in red. .... 111

Figure 3.19: extract from a competence matrix using the theory/practical split. Each column represents a person. Staff rate themselves from 0 to 5, with 5 being a world class expert. .... 113

Figure 3.20: The same extract with the addition of results from the knowledge network analysis, showing both the number (yellow) and sum of ratings (red) of connections from others in the team. .... 114

Figure 3.21: The anonymised Competence Matrix for Company 6. .... 115

Figure 3.22 (left): Company 6 pull network coloured by self-rated competence at a key Laminating skill (laminating a 1-8-1 carbon mould, practical component). Darker purple is higher rated, white is zero. Non-participants are in red. Nodes sized by weighted PageRank with no damping. ....	117
Figure 3.23 (right): Company 6 pull network coloured by self-rated competence at a key Fitting skill (drilling, practical component). Darker blue is higher rated, cream is lower rated. Non-participants are in red. Nodes sized by weighted PageRank with no damping. ....	117
Figure 3.24: Number of participants in each category from Canada and the UK. ....	118
Figure 3.25: Participant ages by organisation type. ....	119
Figure 3.26: Participant job types by organisation type. Job types were selected on a Venn diagram showing Computer, Hands-on, Meetings and intersections between each and all three. ....	119
Figure 3.27: Percentage of participants who agree (4 or 5 out of 5) with the statements given. ....	121
Figure 3.28: number of participants who answer yes (green), sometimes (yellow) or no (red) when asked whether or not they or their teams carry out the listed tasks. ....	122
Figure 3.29: Percentage of participants in each organisation type who consider the listed knowledge transfer methods useful. ....	123
Figure 3.30: Percentage of participants who ranked these options in their top 3 choices when asked 'where do you go to first for specific queries?' ....	124
Figure 3.31: Percentage of participants who ranked these options in their top 3 choices when asked 'where do you go first for generic information'? ....	125
Figure 3.32: Percentage of participants who rank each option as 'useful' (4, 5 or 6 out of 5). ....	126
Figure 3.33: How often would you be willing and have time to contribute to a wiki or forum? Percentage of participants by organisation type. ....	128
Figure 3.34: How often would you be willing and have time to contribute to a wiki or forum? Raw number of participants shown by job type, across all participating organisations. ....	129
Figure 4.1: M21 viscosity (green) and degree of cure (purple) over selected cure cycle (temperature in red). Based on cure kinetics model of Kratz et al. [43] ....	138
Figure 4.2: Nikon XTH-320 CT Scanner ....	139
Figure 4.3: Start of cure ....	140
Figure 4.4: Scan 5 (40 minutes). ....	140

Figure 4.5: Scan 10 (90 minutes).....	140
Figure 4.6: Scan 15 (140 minutes), high density contaminant circled.....	141
Figure 4.7: Scan 20 (190 minutes).....	141
Figure 4.8: Scan 25 (240 minutes), cooling.....	141
Figure 4.9: Experimental setup showing cure apparatus and sample.....	143
Figure 4.10: Experimental equipment in XTH-320 CT scanner cabinet.....	144
Figure 4.11: Experimental setup viewed from above.....	145
Figure 4.12: Close-up view of bagged sample, in position for curing.....	145
Figure 4.13: Scatter free radiographs of sample before (left) and after (right) cure. False colour, with shading correction. Looking end-on at the gap. The black is the ceramic rod and the material to the side and in front of the sample is bagging tape. The acrylic lid is in a bluer colour above. The sides of the acrylic ring and the bag can be seen in grey.....	146
Figure 4.14: Tow gap (a) and Ply drop (b) sample lay-up near the central gaps. (a) shows [0,90] symmetrical layup, with two 0 degree plies in the centre, with the gap in the fibre direction. (b) shows all 90 layup, with the gap across the fibre direction. Arrows mark the expected direction of lateral fibre movement in the tow gap case. The ply drop sample will show if resin movement is sufficient to fill the gap.....	147
Figure 4.15: Temperature measurement baseline.....	148
Figure 4.16: Drawing the region of interest on the 3D reconstruction of the first scan of a tow gap sample. The same region of interest is used on each reconstruction. Space is allowed below the gap as the sample will shrink vertically as it consolidates.....	149
Figure 4.17: Applying region of interest to 3D reconstruction of the last scan. The gap is still within the region.....	150
Figure 4.18: Identifying voids using VG studio max, for the reconstruction shown in Figure 4.16. Extracted void volumes in the region of interest are shown in blue, along each axis and in a 3D representation (black panel), behind a table listing the voids.....	151
Figure 4.19: Tow gap void evolution during cure. Blue bars are total void volume within the region of interest (different shade for each run), red/orange lines show temperature, estimated according to section 4.6.1.....	152

Figure 4.20: Slices through scans of a tow gap sample shown at the start (23 degrees C), 1 hour (39 degrees C), 2 hours (66 degrees C) and the end of the cure: 7 hours 20 minutes, cooled to 69 degrees C. Note that while voids are no longer visible in the 3rd picture, new voids have formed in the final scan of the batch..... 153

Figure 4.21: Distribution of void volumes for first tow gap run. .... 154

Figure 4.22: Comparison of tow gap void evolution with M21 resin behaviour. Resin behaviour calculated from the model of Kratz et al. [43] ..... 154

Figure 4.23: Ply drop void evolution during cure. Blue bars are total void volume within the region of interest (different shade for each run), red/orange lines show temperature, estimated according to section 4.6.1. Two different temperature cure cycles are shown. .... 156

Figure 4.24: Defect evolution and resin behaviour, ply drop gap with ~150°C hold. Resin behaviour calculated from the model of Kratz et al. [43] ..... 157

Figure 4.25: Defect evolution and resin behaviour, ply drop gap with hold at ~140°C. Resin behaviour calculated from the model of Kratz et al. [43] ..... 158

Figure 4.26: Lack of correlation between (a) start and end void volumes, (b) start and minimum void volumes, and (c) minimum and end void volumes in the region of interest. Type 1 is a tow gap, type 2 a ply drop. .... 159

Figure 4.27: Comparison of tow gap and ply drop defect evolution. Resin behaviour calculated from the model of Kratz et al. [43] Tow gap run 1 and ply drop run 1 are shown, as these are closest in hold temperature..... 160

Figure 4.28: Microscopy image of tow gap sample after cure. Magnified cross section through deliberate defect zone only. .... 161

Figure 4.29: Microscopy image of ply drop sample after cure. Magnified cross section through deliberate defect zone only. .... 161

Figure 5.1: The bespoke autoclave (2m internal diameter x 3m length) at the National Composites Centre, with pass-throughs for cure monitoring sensors. The control computer is at the front left. A test part is inside the autoclave, thermocouples attached. .... 166

Figure 5.2: A closer view of a pass-through for the Advise dielectric cure monitoring system. Two channels, each consisting of two cables for sensor data and one thermocouple, enter the autoclave at this point, through a machined flange plate attached to a DN50 port (internal diameter 50mm) for pass-throughs..... 166

Figure 5.3: Signal processing system and control PC for the Advise DETA-Scope Dielectric Analysis system. Two channels and two thermocouples are active. The PC screen shows the monitoring software: temperature (white) and conductivity (red) from one sensor on a completed cure..... 167

Figure 5.4: A Synthesites Optimold cure sensor (left) with a commercial Netzsch Kapton substrate electrode as used with the Advise DETA system (right). The Kapton electrode is approximately 1cm wide..... 167

Figure 5.5: An Optimold signal processing system from Synthesites. This can be attached to a single DC cure monitoring sensor. The PC- not shown- can process signals from multiple sensors simultaneously, measuring resistance and temperature. .... 168

Figure 5.6: Sensor connection points inside the autoclave. Advise DETA sensors and associated thermocouples are connected on the upper two channels. The sensor connectors for the Synthesites Optimold system have been modified- at both ends- to use the lower two channels... 168

Figure 5.7: A test part connected up to the sensor systems (left), vacuum hoses (left top) and autoclave thermocouples (right), inside the bespoke autoclave. The autoclave has an internal diameter of 3m. .... 169

Figure 5.8: Diagram showing the planned layup for a stepped wedge. The blue curves on the side view indicate that plies should be offset slightly to avoid sharp corners at each step, as this causes bridging of the bagging materials and hence poor consolidation in corners. .... 170

Figure 5.9: Three views of a cured stepped wedge. The wedge is 300mm x 150mm. .... 171

Figure 5.10: A GIA electrode (left) with a Netzsch Kapton substrate electrode (right), as used with the Advise DETA cure monitoring system. The Kapton substrate electrode is approximately 1cm wide. The interdigitated electrodes are visible on the GIA electrode, but hidden under a glass fibre veil on the Kapton electrode. The veil prevents the electrode shorting on conductive material such as carbon fibres. .... 172

Figure 5.11: Vacuum bagging diagram for the stepped wedge, showing sensor positions, bagging materials and breach ports for vacuum hoses- one to apply the vacuum and another to monitor it. .... 173

Figure 5.12: A cured stepped wedge in the autoclave with vacuum hoses, DEA sensors (gold strips passing into PEEK connector protection cylinders, J type thermocouples (black and white) and DC sensors (red and white) are connected front and rear. K type thermocouples (green and white) are on the right. .... 174

Figure 5.13: The energy monitor on the autoclave electrical cabinet, showing current and total energy usage in kWh. Readings were taken before and after each cure. .... 174

Figure 5.14: Typical output from the Optimold sensors, with two sensors during a two hold cure. Due to the cables used, the values given for temperature and resistance are not accurate- they are later adjusted by reference to the autoclave thermocouples- but the graph shapes indicate the progress of the cure. .... 175

Figure 5.15: Cable compensation in the Advise DETA system ..... 175

Figure 5.16: Examples of viscosity and degree of cure signals from the Advise DETA system, two sensors shown..... 176

Figure 5.17: The manufacturer’s recommended cure cycle for 8552. Reproduced from Hexcel datasheet [13]. ..... 178

Figure 5.18: Autoclave pressure sensor and thermocouple output for cure cycle 1. Thermocouple 3 is very noisy so was removed as a control thermocouple as the readings were unreliable. Here we can see an exotherm in the thick end just before the 180°C hold ..... 181

Figure 5.19: Autoclave thermocouple and pressure sensor output for cure cycle 2, a single hold at 180°C. The exotherm occurs just before the cycle enters the 180°C hold..... 182

Figure 5.20: Raven process map for 8552 using the NCAMP model, with paths for different cure cycles shown. Isotemporal contours have increments of 1 minute (green), 10 minutes (red), 30 minutes (blue) and 60 minutes (magenta). The red diagonal line represents the relationship between degree of cure and  $T_g$ . ..... 183

Figure 5.21: Autoclave thermocouple and pressure sensor output for cure cycle 3, a dual hold at lower temperature (for the second hold only). ..... 184

Figure 5.22: Autoclave thermocouple and pressure sensor output for cure cycle 4. The slight depressurisation during the exotherm is due to rapid cooling by the autoclave’s automatic systems, in an attempt to return the thicker end of the wedge to the desired temperature- in this case 160°C. .... 185

Figure 5.23: Autoclave thermocouple and pressure sensor output for failed cure cycle 5. Here the dielectric sensor in the thin end of the wedge failed, so the autoclave was moved to the cool down segment when only the thick end had reached 85% degree of cure, resulting in a more truncated cure than true cure cycle 5. Hereafter referred to as cycle 7. .... 186



Figure 5.24: Autoclave thermocouple and pressure sensor output for cure cycle 5. After the initial hold at 110°C, the cure proceeds towards a 180°C hold as in cure cycle 1. When the Advise DETA dielectric sensors in both extremes of the wedge report a degree of cure of 85% or more (the thick end reaches 85% first), the autoclave automatically moves to the cool down segment of the cure. 187

Figure 5.25: Autoclave thermocouple and pressure sensor output for cure cycle 6. The autoclave ramps up the temperature towards 180°C for a single hold, and automatically moves to the cool down phase when the Advise DETA dielectric sensors report a degree of cure of over 85% in both extremes of the wedge. .... 187

Figure 5.26: Approximate indication of cutting lines (red) and possible sample sites (blue) on stepped wedges, with samples from close to the central red line being preferred. Samples were supposed to be taken from the centre of each step vertically, though in some DMA samples this was not the case. These were repeated and the effect of sample positioning is highlighted in the DMA section. .... 189

Figure 5.27: DMA results for the first stepped wedge, cure cycle 1 (standard). The cure cycle is shown on the inset graph.  $\tan \delta$  is shown for all five steps, from 1 (thinnest) to 5 (thickest). .... 192

Figure 5.28: Sim: Theoretical simulation for Step 5 in cure cycle 1. The cure cycle is shown in blue, and the expected temperature of the part at the top (full line) middle (dashed line) and bottom (dotted line) is in cyan. Degree of cure (blue dashed line),  $T_g$  (red line) and resin viscosity (green line) are shown for the centre of the step. Degree of cure is on the external right axis and resin viscosity on the internal right axis. .... 195

Figure 5.29: Sim\_data: Simulation for Step 5 of cure cycle 1 based on thermocouple data from the centre of the step. The temperature profile from the thermocouple is the blue line. Degree of cure is on the external right axis and resin viscosity on the internal right axis. .... 195

Figure 5.30: Comparison of  $T_g$  by DMA  $\tan \delta$  peak (green), Raven simulation based on thermocouple data (Sim\_data)(darker blue) and Raven simulation based on theoretical cure cycle (Sim) (lighter blue). .... 197

Figure 5.31: Comparison of Degree of Cure by DSC (green), Raven simulation based on thermocouple data (Sim\_data) (darker blue) and Raven simulation based on theoretical cure cycle (Sim) (lighter blue). .... 199

Figure 5.32:  $T_g$  - degree of cure relationship for 8552 based on laboratory tests, DMA  $\tan \delta$  peak and DSC respectively. Red oval: steps 1 and 2 for cure cycle 4, DMA thought to be anomalous. Blue oval: step 5 from cure cycles 2 and 6, where the exotherm is highest and degree of cure is highest. Purple:

Standard temperature full length cure. Green: cool full length cures. Error bars are not shown here for ease of viewing..... 202

Figure 5.33:  $T_g$  - degree of cure relationship from Raven simulations based on thermocouple data. .... 203

Figure 5.34: The study used to develop the NCAMP model shows that the drop in  $T_g$  at high degree of cure due to degradation is not included in this model. Reproduced from [23]..... 204

Figure 5.35: Laboratory and simulation based on thermocouple data results for  $T_g$  - degree of cure relationship, disregarding laboratory results showing  $T_g$  degradation and anomalies. 2<sup>nd</sup> order polynomial trendlines. .... 204

Figure 5.36: Comparison of  $T_g$  measurements for the thin end of the wedge (Step 1) for each cure cycle. Error bars are  $\pm 8^\circ\text{C}$  for DMA and  $\pm 5^\circ\text{C}$  for DEA. Note that the DMA measurement for cure cycle 4 is anomalous, here the DEA measurement is noticeably higher than the DMA measurement. .... 206

Figure 5.37: Comparison of  $T_g$  measurements for the thick end of the wedge (Step 5) for each cure. Error bars are  $\pm 8^\circ\text{C}$  for DMA and  $\pm 5^\circ\text{C}$  for DEA. The two full temperature single hold cures, where step 5 experienced  $T_g$  degradation, are the only cases where the DEA measurement exceeds the DMA measurement..... 206

Figure 5.38: Comparison of degree of cure measurements for the thin end of the wedge (Step 1) for each cure cycle. Error bars are  $\pm 2\%$  for DSC and  $\pm 2\%$  for DEA. The target of 85% degree of cure is marked in yellow..... 209

Figure 5.39: Comparison of degree of cure measurements for the thick end of the wedge (Step 5) for each cure cycle. Error bars are  $\pm 2\%$  for DSC and  $\pm 2\%$  for DEA. The target of 85% degree of cure is marked in yellow..... 209

Figure 5.40: Comparison of degree of cure data for the thin (upper) and thick (lower) ends of the stepped wedge throughout the manufacturer’s recommended cure cycle. Temperature measurements in red, data from DEA sensors in yellow, simulation based on thermocouple measurements in blue. .... 210

Figure 5.41: Comparison of DEA sensor results to laboratory DMA and DSC tests and Raven simulations based on thermocouple data, following Figure 5.35. The laboratory results showing  $T_g$  degradation and those which are anomalously low  $T_g$  are not included. The uppermost DEA result is the equivalent of one of these where the laboratory results show degradation. .... 211

Figure 5.42: Output from Advise DETA system for cure cycle 1. The top pane shows conductivity (white) and temperature (red) in step 1. The middle pane shows viscosity in step 1 (white) and step 5 (red). The lower pane shows degree of cure in step 1 (white) and step 5 (red). ..... 212

Figure 5.43: Optimold DC sensor output for cure cycle 1. The thick lines represent temperature and the thin lines resistance. The offset in temperature can clearly be seen here- the first hold is at 110°C for both ends of the wedge, and the second at 180°C, again for both ends. The orange highlight shows a feature which the Synthesites model for this resin currently cannot fit, shown more clearly in Figure 5.45. .... 213

Figure 5.44: Illustration of  $T_g$  estimate provided by Synthesites, in this case for cure 0 at the thin end. .... 214

Figure 5.45: Optimold sensor outputs for cure cycle 7. The thick lines denote temperature and the thin lines denote resistance. Note the offset between the temperature measurements, these are not correct, but can be corrected in post-processing. However, Synthesites indicated that the plateau in the resistance lines (highlighted in orange) cannot be fitted to their model..... 215

Figure 5.46: Damaged electrical connector for an Advise DETA-Scope flexible connector. Approximately 1cm in width. Connector and disconnected wire circled in blue. Here the solder has given way when the sensor was removed. In the background, a GIA sensor which has absorbed resin can be seen. .... 217

Figure 5.47: Protective cover for connector, with flexible sensor attached. Sensor ~1cm wide. .... 218

Figure 6.1: Landing page of Knowledge Transfer Resource for Dielectric Monitoring in Composites Manufacture. .... 225

Figure 6.2: Manufacturing use cases slide design showing the five industrial categories of Fabris and Poursartip [115] alongside links to case studies, a video and external references, plus a quick return to the landing page. .... 226

Figure 6.3: Case study slide which links to the ‘How it works’ science section (comparison to laboratory tests) and one of the relevant industrial categories (Equipment), with reference to the source (Thesis). .... 227

Figure 7.1: Horizontal slices through the centre of CT reconstructions of a tow gap during cure. Top left: original defect. Top right: 1 hour, 39°C, resin flowing into defect. Bottom left: 2 hours, 66°C, gap appears full. Bottom right, end of cure, voids now visible in position of original defect. Chapter 4. .... 237

Figure 7.2: Active process control. When both sensors reach 85% degree of cure (lower graph) the autoclave automatically cools down and ends the cure (upper graph). Sensor controlled single hold cure, Chapter 5..... 239

## Table of Tables

Table 1.1: Materials for bagging a composite part.....	11
Table 1.2: Definitions of knowledge management terms .....	20
Table 2.1: Cure kinetics parameters for M21 resin, from model by Kratz et al [43] .....	30
Table 2.2: Table listing popular cure monitoring techniques, reproduced from [46]. .....	33
Table 3.1: Self rating levels in questionnaire .....	113
Table 5.1: Vacuum bagging materials.....	173
Table 5.2: Cure cycles to be tested. ....	179
Table 5.3: Exotherm extent in steps 4 and 5, to the nearest °C. The autoclave’s stated accuracy is +/- 3°C. Single hold cures are highlighted and 160°C cures are in italics. ....	188
Table 5.4: Degree of cure of each step in each wedge as determined by Digital Scanning Calorimetry, taking the mean of three tests for each value. ....	190
Table 5.5: $T_g$ measured by DMA $\tan \delta$ for each step in each wedge. For cure cycle 2, a drop in $T_g$ can be seen for step 5- this may be due to degradation caused by the exotherm. Anomalous results in red. ....	192
Table 5.6: Cure cycles. The reader is strongly advised to take a photograph of this for easy reference. ....	193
Table 5.7: $T_g$ by DMA compared to Raven simulations based on thermocouple data (Sim_data) and on theoretical cure cycles and heat transfer model (Sim). Results for each step from thin (Step 1) to thick (Step 5). DMA results in red are considered anomalous. ....	196
Table 5.8: Degree of cure by DSC compared to Raven simulations based on thermocouple data (Sim_data) and on theoretical cure cycles and heat transfer model (Sim). Results for each step from thin (Step 1) to thick (Step 5). ....	196
Table 5.9: Comparison of $T_g$ results from DMA, DEA and Raven simulation based on thermocouple data. ....	207
Table 5.10: Degree of cure results from DSC, DEA and Raven simulation based on thermocouple data .....	208

Table 5.11: Table of results comparing $T_g$ estimates by DMA, DEA, DC sensors (Optimold) and Raven simulation based on thermocouple data. Synthesites did not supply an indication of the error on their $T_g$ estimate. ....	215
Table 5.12: Energy usage, cost, equivalent carbon dioxide emission and equivalent miles that can be driven in a standard petrol car for that amount of emission, for each cure cycle. $T_g$ values are as measured by DMA tan $\delta$ peak and degree of cure values are as measured by DSC. The suggested optimum cure cycle of these options, 6, is highlighted in green and the recommended cure cycle, 0, is highlighted in cyan for comparison. ....	219
Table 5.13: Cure cycles, for reference. ....	219







# Chapter 1

## 1 Introduction

### 1.1 Scope of Work

This thesis seeks to contribute to improving the efficiency of the manufacture of advanced composite parts. In-process monitoring techniques can be used to both optimise aspects of the manufacturing process and to further our understanding of defect evolution. Effective knowledge transfer is vital both to run a manufacturing business efficiently and to enable the transfer of useful technologies from academia to industry.

The work presented herein includes a study of knowledge transfer both within and between academic and research organisations and Small and Medium Enterprises (SMEs) in the advanced composites space. Through questionnaires carried out with as many people as possible at each organisation, knowledge transfer is studied at the individual level. Knowledge network visualisations are presented and discussed. The same study gathered data on participants preferred methods for learning, which informed the design of the Knowledge Transfer Resource for dielectric monitoring.

This resource includes background information on the technology and how it can be used in composites manufacture, relevant results from the literature and results obtained in this work.

Degree of cure and glass transition temperature measured using dielectric cure monitoring sensors are compared to simulation and to laboratory tests for a varying thickness part, over a variety of different cure cycles. The dielectric sensors are used for active process control, in this instance cooling the autoclave when a specified degree of cure is reached or exceeded in both extremes of thickness. Energy usage over different cure cycles is compared and the practicalities of using this sensor system in an industrial environment are discussed.

Tracking of defect evolution is carried out using in-process micro-XCT, where small composite parts are cured in-situ in an industrial CT scanner, and fast scans used to study the changes in the defect, achieving the first in-process micro-XCT scans through the cure of an advanced composite item. This was used to track the changes in void volume as two defect types- tow gaps and ply drops- were cured, both demonstrating the potential utility of the method and showing evidence for an increase in void volumes at minimum resin viscosity. The two defect types are compared.

## 1.2 Problem Statements

### 1.2.1 Knowledge transfer in academia and composites SMEs

A study of knowledge transfer within and between academic groups and SMEs in the composites industry may highlight problems, allowing them to be fixed, and inform the development of improved knowledge transfer between academia and industry.

Knowledge is held in the minds of employees, and thus can walk out of the door if not transferred within the organisation. Lack of communication, or an individual not knowing who to talk to about a particular issue, can cause problems in any organisation. Small and Medium sized Enterprises can miss out on useful new developments or assistance in solving problems knowledge transfer links with academia are insufficient. Preferred methods of learning may differ between academia and industry. Knowledge management practices include techniques for studying these issues, which have not thus far been applied to the organisations in question.

A knowledge transfer study is carried out by questionnaires with academic groups and SMEs in two countries, plus a research institution with a remit for improving links between academia and industry in one of the countries. Individual results are provided to the participating institutions. Collectively the results are used to provide a snapshot of knowledge transfer between the participating institutions and opinions and preferences in the different types of organisations.

### 1.2.2 Measurement of defect and feature evolution during cure

If the evolution of defects or features could be measured during the cure process, it would then be possible to test aspects of a design or the response of unavoidable defects to different cure cycles during the research and development phase for a new product.

Unintentional defects can lead to scrappage, unavoidable defects- which occur due to the part geometry- affect the properties of the final part and hence the amount of material needed. As resin flows and fibres shift, the defect may undergo significant changes during cure, which may not be obvious from only 'before' and 'after' measurements or multiple partially cured samples- in which the defect geometry will vary. Fast and high resolution micro-XCT scans can be achieved using a synchrotron, but this is not a practical solution for regular use in industry.

An industrial micro-XCT scanner is equipped with a heated tool and vacuum system to enable cure of small composite items within the cabinet. This method is used to track the evolution of two types of gap in the composite layup, one of which is expected to close over more than the other during cure due to lateral fibre movements. This is the first demonstration of in-process micro-XCT during composite cure.

### 1.2.3 Cure monitoring for optimisation, active process control and quality assurance

Active process control based on real time measurements of material properties during cure would allow the cure of composite items to be optimised while ensuring the required material properties are obtained. The record of measurements taken throughout the cure may be used for quality assurance.

Standard, recommended cure cycles must work for composite parts of varying geometry made from material with variation between batches, while absolutely guaranteeing that certain final material properties are obtained, so can use significantly more time, energy and hence money than is needed. Material properties are not commonly tracked during the cure. Temperature measurements in combination with a theoretical model of the cure may be used as a proxy, but this does not allow for variations in resin batches, and if measured only in set places may miss issues such as temperature gradients across the autoclave. Dielectric analysis can be used to track material properties during cure but is little known in industry.

A dielectric analysis system is integrated with an industrial autoclave for cure monitoring and control. Stepped wedge test parts with dielectric sensors at the thin and thick extremes are cured following a range of different cycles, including cases where the autoclave automatically ends the cure and cools down when the required material properties are obtained, demonstrating active process control. Energy use is monitored. The results of the dielectric analysis system are compared to laboratory tests and simulation to assess their reliability and the practicalities of using this system in an industrial environment are considered.

### 1.2.4 Knowledge transfer resource for technology transfer from academia to industry

An industrially focused knowledge transfer resource could assist in facilitating technology transfer from academia to industry.

Technologies, such as dielectric cure monitoring, may languish in academia for decades without successful transfer to industry despite potential to be useful. Small and Medium sized Enterprises may have sufficient flexibility to test new developments and make use of them, but often do not have large research and development departments. Industrialists, particularly at SMEs, may not have access to academic forms of communication such as journals. Industrial needs for a technology are different to academic needs.

A knowledge transfer resource for the example technology of dielectric cure monitoring is constructed, designed around industrial requirements when considering a new technology and case studies of useful applications, with reference to the preferences for knowledge transfer in the composites industry from the questionnaire based study described above.

### 1.3 Thesis Structure

This first chapter introduces the themes and techniques relevant to this work and is intended to be an easily understood primer for those who have not encountered either advanced composites or knowledge management before. Knowledge derived from existing literature is codified in the form of Chapter 2, where more detail on the scientific background can be found.

A study of knowledge transfer within and between academic groups and composites manufacturing businesses, focused on Small and Medium sized Enterprises, is presented in Chapter 3. Development of a new procedure, in-process micro-XCT Scanning, for the tracking of defect evolution during cure (Chapter 4); and application of existing technology, little used in industry, to cure cycle optimisation, in the form of dielectric cure monitoring (Chapter 5); and have been selected to demonstrate both their potential for improving composites manufacture and the value of knowledge transfer from academia to industry.

An industrially focused knowledge transfer resource for dielectric cure monitoring is presented in Chapter 6. This is an example of a format which could be applied to a variety of topics and technologies, and includes multimedia elements. This chapter is best experienced with reference to the knowledge transfer resource itself, included as a linked .ppt file on the attached memory stick, though images of the slides are also included in the appendix.

The author discusses the implications of the results and potential opportunities for expanding on this work in Chapter 7. Conclusions are summarised in Chapter 8.

The remainder of this chapter comprises an overview of the general background to the work carried out in this thesis, intended for the non-specialist reader.

## 1.4 Advanced Composites

A composite is, by definition, anything made of more than one material [1]. This could be aggregate, reinforced concrete- even wood, consisting of naturally occurring fibres and resins. However, in advanced composites, the term is used a reference to continuous fibre reinforced plastics.

'Carbon fibre' is generally considered a high-tech item, used to create cutting-edge aircraft, formula 1 cars and lightweight bicycles. In all these examples, the 'carbon fibre' components are in fact advanced composites. For ease, these will henceforth be referred to as *composites*, where an individually manufactured piece is a *composite part*.

Other fibre reinforcements exist- glass fibre is often cheaper and widely used in everything from boats to bathtubs, wind turbine blades, pressure vessels and more. Aramids such as Kevlar can also be used. As sustainability becomes an ever more important consideration, research is ongoing towards use of natural fibres, such as cellulose, in reinforcements.

While the fibres are perhaps the more celebrated partner, without resin there would be no composite parts. A bicycle made only of carbon fibre, without resin, would collapse under gravity into a pile of fabric. The resin- a plastic- is crucial to the structural properties of the final part, for the reinforcement can only be of use when reinforcing something.



Figure 1.1: Making a composite part.

Resins fall into two categories- thermoplastics and thermosets. Thermoplastics can be melted and separated from the fibres, so are in principle good for recycling, but are expensive, often require higher temperatures for processing and are not suitable for all applications. Most manufacturing at the moment focuses on thermoset resins, which undergo a chemical reaction during the process, permanently forming the part into the desired shape.

This is an energy intensive process, involving heat and pressure. The resin starts to flow as heat is applied, allowing it to move between the fibres. As the heat increases, chemical bonds form within the resin, crosslinking between polymer chains until the part is permanently fixed in the desired shape. This is referred to as *curing*. This process itself gives off more heat- so one must be careful to control the conditions to avoid a runaway exothermic reaction (*exotherm*) and associated building evacuation.

---

### **Degree of cure**

*A part with 100% degree of cure is as fully crosslinked as possible. In reality, this is near impossible to achieve, as the rate of increase of degree of cure slows as the 3D polymer structure becomes full of bonds. For practical purposes, the required degree of cure varies depending on what the part will be used for.*

### **Glass transition temperature, $T_g$**

*In its low temperature state, a cured polymer resin is glassy- hard and rigid. Above the glass transition temperature,  $T_g$ , the interlinked polymer chains can move over each other so the resin becomes rubbery.  $T_g$  is determined by the chemistry of the resin and the degree of cure. As cure proceeds, the polymer chains become increasingly interlinked, so at a higher degree of cure the glass transition occurs at a higher temperature, though the relationship may not be linear. It is not a discrete, definite temperature, but a range over which the transition occurs, so different methods of measuring  $T_g$  may give slightly different results. For most applications, where a rubbery part is not desirable, the glass transition temperature of the cured composite dictates the upper bound of its usable working temperature.*

---

## 1.5 Uses of Composite Parts

Composite parts, properly designed, can be far lighter than equivalent parts made of metals or other materials while delivering the required properties for the part to carry out its function. Unlike homogenous materials, the fibres in a composite part can be positioned to deliver different properties in different directions.

These advantages, among others, have led to the creation of a large and growing industry. The 2016 UK Composites Strategy [2] estimates the current size of the UK market in composites manufacture at £2.3bn, with a forecast of reaching up to £12bn by 2030. This is across a diverse range of sectors, as shown. For the global market, the same report claims:

*“The Global Market for composite products in 2013, across all sectors, had a value of US \$68.1bn. The overall market is expected to grow at around 6.5% CAGR over the next 7 years to about \$105.8bn in 2020.” [2]*



Percentage figures are Compound Annual Growth Rate (CAGR). The forecast figures reflect the view of UK supply chain companies in research carried out by the NCC in mid-2015.

Figure 1.2: UK Composite Market according to Composites Leadership Forum. Reproduced from [2]

An example can be seen in BMW's investment in composites manufacture- including investing in their carbon fibre supply chain- in order to make the i3, and some subsequent vehicles, with a mostly composite chassis [3]. The increasing popularity of such electric cars, needing to maximise range from a limited amount of battery, and increased taxes on fuel and carbon dioxide emissions do a lot to encourage lightweight vehicles even where environmental concerns fail to motivate.

As advanced composites become more prevalent, then, it is increasingly vital to manufacture them efficiently. Fewer parts discarded due to defects reduces pressure on the limited supply of material, as well as saving money. Energy efficient manufacturing processes are of obvious value, and the underpinning knowledge management required to ensure these new technologies are used in the best possible way are equally important, along with identifying expert people and working to help them pass on what they know and ensuring a supply of suitable staff for the future.

## 1.6 Manufacturing

There are many routes to manufacture, which, for thermosetting composites, can be split into two broad categories:

- 1) Form fibres into desired shape, add resin, cure
- 2) Combine fibres and resin, make into desired shape, cure

The fibres may be unidirectional, woven into a fabric, or braided into a three dimensional shape. Where the structural requirements are minimal, short strands of chopped fibre may also be used. This is a possible fate for fibres recovered from recycling of composite parts.

### 1.6.1 Route 1

Where dry fibres are used, they may be placed into a mould or shaped over a tool by hand or, where the shape is appropriate, using robotic tools, including Automated Fibre Placement (AFP). [4] The resin may be poured or injected into a mould or heated press, or infused with the help of a vacuum pump. Monitoring and controlling resin flow is an area of interest as any dry spots left after cure render the part scrap. Where a heated press is used, the part is cured while in the press. Otherwise, it is heated after resin infusion (e.g. in an oven), unless a room temperature curing resin is used.



Figure 1.3: The Schuler Press at the National Composites Centre. Image from National Composites Centre.[5]

### 1.6.2 Route 2

Fibres and resin can be combined and shaped as part of the same process. Pressure vessels and pipes are often made by *filament winding*, where the fibres pass through a resin bath on their way to being wound around a mandrel. The final product must be cured, usually in an oven or autoclave. In *pultrusion*, the cure is part of the process- fibres are combined with resin and pulled through a heated die, which cures the resin, resulting in long parts with the same cross-sectional shape.

For parts where structural properties are not so important, short fibres can be combined with resin and applied to a mould like a thick liquid, often as a spray. Again, this must then be cured.

However, one of the most common manufacturing methods involves sheets or tapes of fibre reinforcement pre-impregnated with resin, known as *prepreg*. This is a sticky fabric, which can be laid up into the desired shape for the part by either humans or robots. A laminator places pre-cut plies of prepreg onto a tool, manipulating the material to ensure it fits correctly into every detail of the shape and pressing it down to stick each layer in place. The design of the part must account for the way the material needs to be stretched and positioned to achieve the desired shape.





Figure 1.4: Hand layup of prepreg. Image from National Composites Centre.[5]

While advances are being made in the robotic realm, including pre-shearing and robots with multiple tools [6], most complicated parts- such as aircraft fuselage panels- are laid up by hand, as robots have yet to duplicate the dexterity and range of movement available to a human. Manually achieving sub millimetre accuracy is extremely difficult, even with the aid of projected guidance lines [4], and skilled laminators are in high demand. For either flat panels or shapes with simple, smooth curvature, Automated Tape Laying (for flat panels) and Automated Fibre Placement (for curved parts) can be used. Prepreg (or sometimes dry fibre) tape is deposited onto a shaped tool by a roller on an articulated robotic arm. Without the heat of a human hand to warm the fabric and enable it to stick, the robot must instead use a lamp or laser. Among many possible defects, gaps between prepreg tows, parallel to the fibre direction, can occur and where the tape ends, with a cut across the fibre direction, the next tape cannot be lined up exactly, resulting in either an overlap or a small area where a layer of prepreg is missing before the next tape starts, referred to as a ply drop [7]. These defects affect the final properties of the part, and sometimes cannot be avoided due to the part geometry.

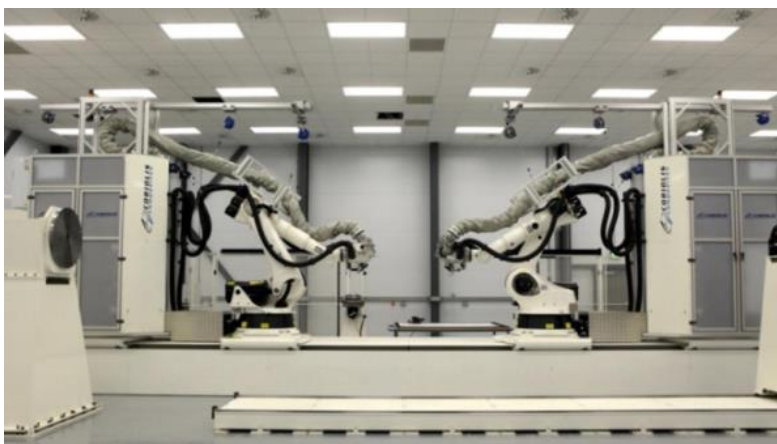

Figure 1.5: Automated Fibre Placement Robots on 7m linear axis. Each head can lay up 8x 6.35mm width tows [8]. Images from National Composites Centre.[5]

### 1.6.3 Cure

Whether in an autoclave, press, oven, heated tunnel or even at room temperature, the thermosetting resin must be cured. Heat provides the activation energy for the formation of chemical bonds in the resin. These reactions are exothermic, so heat from the initial reactions can then contribute to the energy required for the next bonds to form, and so on. Controlling the temperature in the composite part is vital, to ensure that sufficient bonds form but prevent a runaway exothermic reaction from occurring. If the resin is overheated it may burn (if oxygen is available) or otherwise break down.

Autoclaves, ovens and heated presses can contain thermocouples linked to their temperature control systems, ensuring the equipment and the composite therein does not overheat. Thermocouples placed in contact with the part, or- where the structural effects are unimportant- inside the part, can be used. This is the most common form of cure monitoring, tracking the temperature only.

Pressure and/or vacuum are used to ensure good consolidation in the composite, minimising gaps, air pockets (voids) and, where liquid resin has been used, dry spots. This is vital where the composite part is important for structural integrity, such as a spar in an aeroplane wing, but matters even in non-life-threatening situations. One would not take a bath in a tub with a hole.

#### 1.6.3.1 *Vacuum bagging*

With the exception of presses and closed resin transfer moulds, where the composite part is cured between two matching halves of a shape which join tightly together, the composite part will be cured inside a vacuum bag.

In this example, for prepreg cured in an autoclave, the composite is covered in multiple layers of material. Release film is a thin, flexible plastic, which does not stick to resin- so it prevents the resin from sticking to anything else. Breather is a porous cloth which serves to ensure there are air paths from the whole part to the vacuum pump, preventing the top layer from sealing around the valve and cutting off the rest of the part. This top layer is the vacuum bag: a thick, flexible plastic sheet suitable for use at high temperatures. Cork can be used as a support for thermocouples or sensors.

The vacuum bag is stuck to the tool with a thick and sticky tape suitable for use at the cure temperature (bagging tape), into which the bag edges are pressed to ensure a good seal. Breach ports connect the bag to hoses which plug into a vacuum pump or the integral vacuum system of an autoclave or oven.

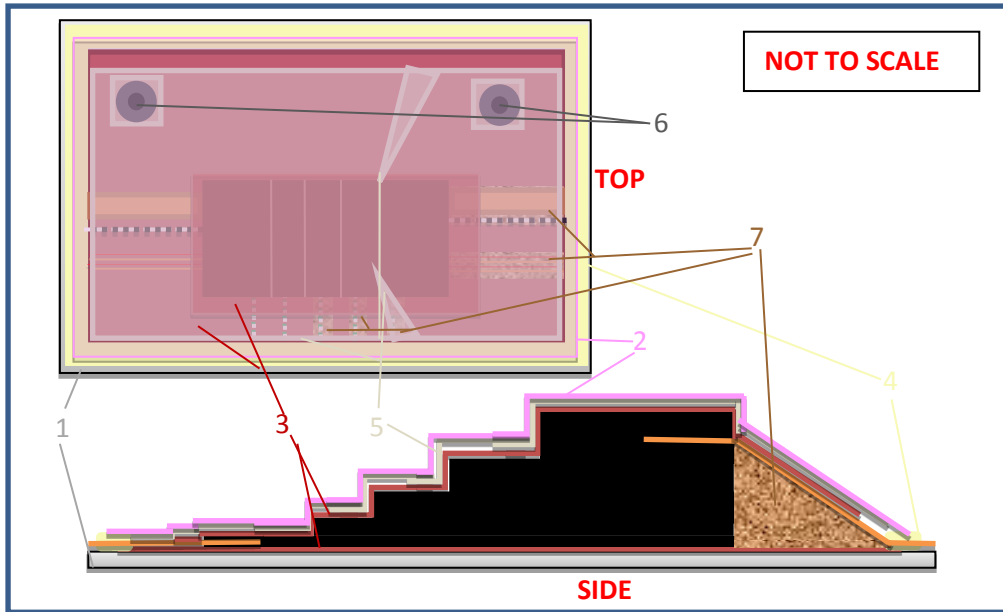

Figure 1.6: Bagging diagram for a composite part.

No.	Description
1	Tool Plate
2	Vacuum bag
3	Release film (non perf)
4	Bagging tape (up to 200°C)
5	Breather fabric
6	Vacuum breach port locations
7	Cork

Table 1.1: Materials for bagging a composite part.

Vacuum is sufficient to noticeably consolidate the composite part, and for some applications this is all that is needed. Where the final part must be further consolidated, an autoclave or press is used.

#### 1.6.3.2 Ovens and autoclaves

Once vacuum bagged, the part is often cured in an oven or autoclave. The vacuum ports and any thermocouples are connected to the autoclave. The cure cycle is specified as a recipe. After curing the part is removed and de-bagged. The composite part is now set in the desired shape.



Figure 1.7: Autoclave, 11.2m long x 3.55m diameter [8]. Image from National Composites Centre.[5]

## 1.7 Efficiency

When considering these many routes to manufacture, a business must weigh up the requirements for the final part against the pros and cons of each. An AFP- built bathtub might do the job, but unless the customer is especially gullible the business will not recoup the costs of manufacture. Composite parts for spacecraft are not likely to be made by short fibre sprayup [9]–[12].

The principles of using both knowledge management and in-process monitoring to increase manufacturing efficiency can be applied to any of these routes. Indeed, a better understanding of knowledge transfer can be useful in any industry. An AFP-type defect in prepreg layup was studied when developing In-Process XCT Scanning. Cure cycle optimisation has been studied by instrumenting an autoclave, as autoclaves remain popular in industries such as aerospace and are energy intensive.

### 1.7.1 Energy efficient cure

The recommended cure cycle for the widely used Hexcel 8552 prepreg [13] in a small (2m working diameter by 3m working length) autoclave uses approximately 180kWh of energy (see Chapter 5), and takes 6 hours. Most industrial autoclaves are far larger. For a business running continually; 3 runs per day, 7 days per week; with even this small autoclave, the yearly cost of this energy would be ~£28,000 and the equivalent yearly emission of carbon dioxide would be ~100 tonnes [14].

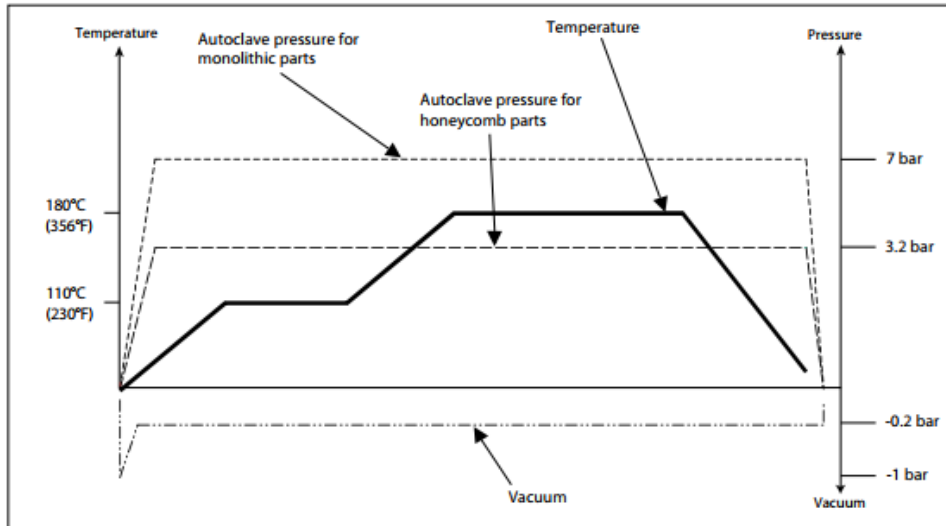

Figure 1.8: Hexcel's recommended cure cycle for 8552. Reproduced from Hexcel 8552 Data Sheet [15].

The recommended cycle, quite reasonably, errs on the side of caution. However, if the part should reach the required degree of cure- which varies with the part design and its intended job- early in this cycle, following this recipe may use energy- and hence money- needlessly.

Simulation can be used to predict the best possible cure cycle for a part- where 'best' might mean lowest energy usage, quickest that does not result in a runaway exotherm, or cheapest that fits in a standard factory shift pattern, among other things. However, simulation does not always reflect reality- particularly where the conditions may vary rather than sticking to a theoretical ideal.

The progress of the cure can be tracked directly using sensors placed in contact with the resin [16]. Either through trial and error or combined with a theoretical model, these sensors can be used to optimise the cure cycle for the part. Direct feedback from the sensors to the autoclave control system could, in theory, be used to adjust the cure cycle based on what is really happening [17]. An implementation of this- automatically cooling the autoclave when the required degree of cure is reached- is trialled in Chapter 5.

#### 1.7.1.1 Dielectric monitoring

Dielectric monitoring has long been used to study composites and resins in academia [18]–[20] but to date, is rarely seen in an industrial setting. The technology is based on the response of the resin to an electric field. Electrodes are placed in contact with the resin, and a field is applied, with a setup somewhat like a capacitor. Using alternating current, the charges on the electrodes switch back and forth, and the charged species in the resin respond accordingly. The response changes with the frequency of the current. This is measured and used to infer the properties of the resin.

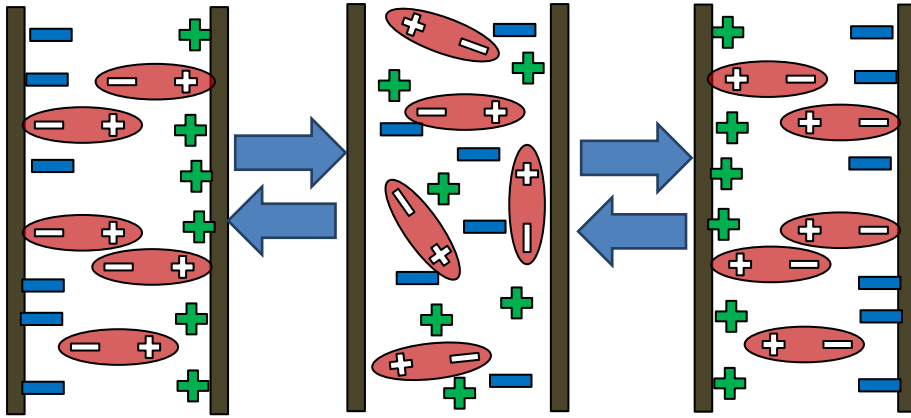

Figure 1.9: Charged particle response to alternating current

As the resin cures, new chemical bonds form and so the response to the applied current changes. On the most basic level, one can see that when the response ceases to noticeably change- and is still within the limits of the equipment, little will be gained by continuing to hold the resin at that temperature. With the addition of a model of the resin behaviour- there are many resins, with different chemical components, so they all respond differently- the degree of cure and glass transition temperature can be tracked by the monitoring system software.

A simpler system based on the same principle of response to an electric field is a direct current (DC) sensor. This measures the resistivity between the two electrodes and can also be used to see when the cure has gone as far as it is going to. It cannot give as much information as the DEA system but may be sufficient for many applications.

A sensor consists of an interdigitated electrode on either a flexible substrate or a robust, reusable mounting for integration into a tool plate. Where carbon fibre, which is electrically conductive, is used, the sensor must be covered with a veil- usually made of glass fibre- through which the resin can pass but the carbon fibre cannot, to avoid shorting.

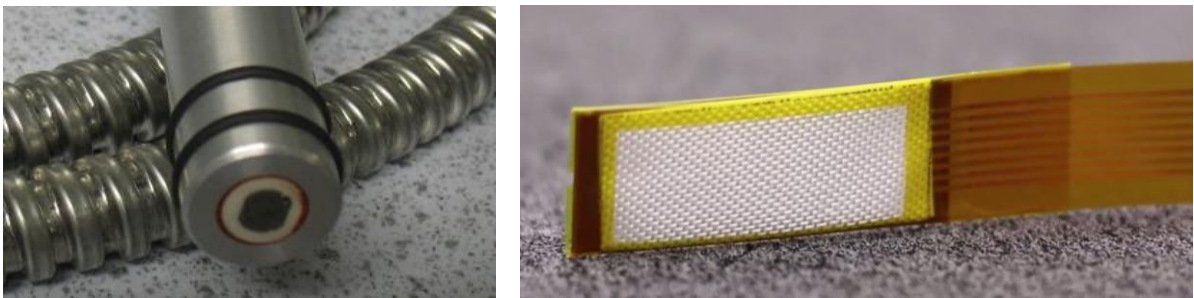

Figure 1.10: Dielectric sensors for tool mounting (left, ~1cm diameter) and internal use (~1cm width strip).

A tool mounted sensor will only track the progress of the cure at the surface. Flexible sensors can be laid up inside a part. Once cured into place, these can be unwelcome as they affect the structural properties. Internal sensors do however give a far clearer overall picture, as cure at critical points inside the part can be measured. The cure will often proceed differently in areas of different thickness. A thick stack of prepreg might initially take longer to heat up than a thinner one- but once the exothermic reaction starts, it will emit more heat.

It seems reasonable to suggest that internal sensors could be used during the prototyping phase, then a tool mounted sensor during manufacture. When using carbon fibre, it is important that the sensor be shielded with glass fibre so that the conductive carbon does not cause it to short out.

#### 1.7.1.2 Comparative measurements

In order to test the dielectric sensors, their measurements must be compared to something. A combination of simulation and physical measurements of degree of cure and  $T_g$  are used.

---

#### ***Differential Scanning Calorimetry (DSC)***

*Differential Scanning Calorimetry is a thermal analysis technique, where the input heat flux required to heat a sample of known mass is compared to that of an otherwise identical empty control vessel, as a function of temperature.*

*To determine the degree of cure of a part, DSC is first carried out using a known mass of uncured prepreg as the test sample. The measured total heat emitted during the cure, per gram of the material, is then recorded as the total enthalpy of reaction.*

*This procedure is then repeated using a sample from the composite part, cut from the position where the measurement is needed. This second test sample, again of a known mass, goes through the exact same process as the first, with the same temperature profile. As this sample is at least partially cured, less heat is emitted as there are fewer unreacted species within the resin. The measured heat emitted for this sample, per gram, is recorded as the residual enthalpy of cure.*

*The degree of cure,  $\alpha$ , is calculated by dividing the sample's residual enthalpy of cure with the total enthalpy of reaction. [21]*

---

---

### Dynamic Mechanical Analysis (DMA)

Dynamic Mechanical Analysis subjects a sample to a sinusoidal oscillation while the temperature is steadily increased. The strain response of the sample is measured and compared to the applied stress. The phase lag,  $\delta$ , between the two waveforms- applied and response- is also measured. These are used to calculate the storage and loss moduli of the sample, which represent stored and dissipated energy, or the stiffness and damping of the material.

$$\text{Storage modulus} = (\text{max stress}/\text{max strain}) \cos \delta$$

$$\text{Loss modulus} = (\text{max stress}/\text{max strain}) \sin \delta$$

As a material passes through the glass transition, changing from a hard, brittle solid to a rubbery state, the response to the oscillation changes dramatically. By plotting the loss and storage moduli, and  $\tan \delta$ , against temperature,  $T_g$  can be estimated- from either the peak in  $\tan \delta$  or the start of the pronounced drop in storage modulus- as the material becomes much less stiff.

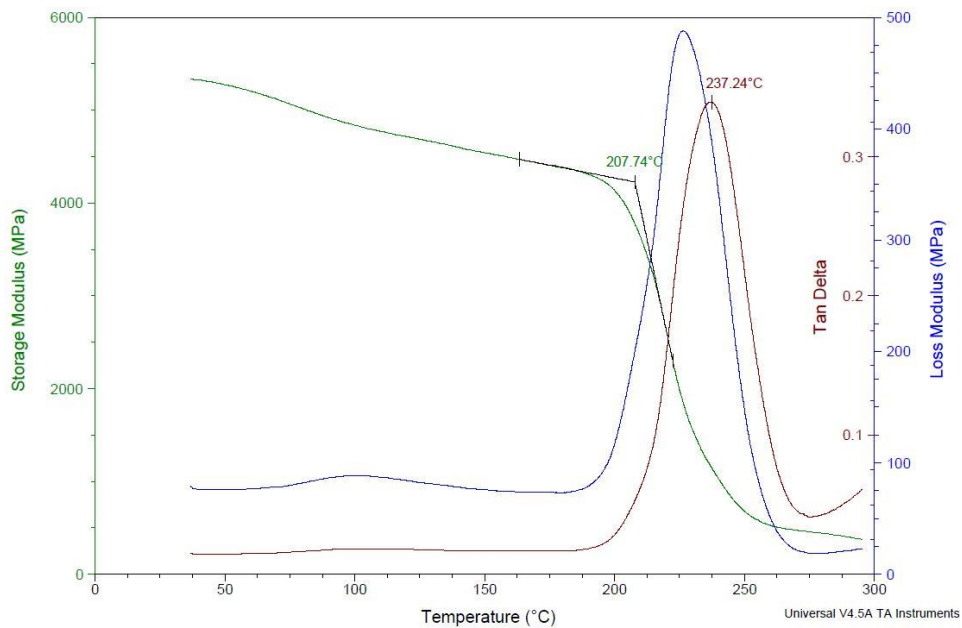

Figure 1.11: Example of  $T_g$  measurement using DMA.

The glass transition temperature,  $T_g$ , is not a single point but a range. It is therefore important to use the same measurement (commonly  $\tan \delta$  peak) for all samples. [21], [22]

---



## *Simulation*

Changes in part properties, including degree of cure and  $T_g$ , can be simulated based on a mathematical model of the resin behaviour, constructed from the results of numerous practical tests- including many DSC and DMA experiments. Commercial simulation tools are available. These can simulate the cure based on either an idealised temperature profile or measurements taken from a real cure, such as from thermocouples embedded in a part while it cures in an autoclave [23].

### 1.7.2 Reducing scrap rate

It is important to reduce the scrap rate of composite parts, being better for the producer and for the environment. Parts with defects may have to be scrapped, so understanding how they form and evolve through the cure process can be useful.

#### *1.7.2.1 Dielectric monitoring*

##### *Wet-out in liquid resin processes*

For liquid resin processes, wet-out can often be a problem. Resin does not always flow into a mould the same way, and dry spots may be left in the preform. A part with a dry spot, once cured, is unlikely to be salvageable. The author has spoken with representatives of manufacturers who claim they lose 10% of some of their products to this problem.

Monitoring the resin flow front by using dielectric or DC sensors to identify resin arrival at key points can either identify simple fixes (e.g. changing pressure application/resin volume/ inlet or outlet positions) or enable online control of the flow.[24] Either way it is possible ensure the part is completely filled with resin. This will lead to fewer rejected parts, so can be of considerable value. A case study is included in Chapter 6.

##### *Material status monitoring*

The amount of time prepreg has spent outside the freezer, variation between batches, local conditions on the day and variations in mixing of resin and hardener for liquid processes, among other things, can all affect the properties of the resin.

Dielectric monitoring can be used to check the status of the material and, where necessary, make adjustments. This could include monitoring the resin:hardener ratio during injection or the degree of cure of any part during processing- either with active control- or simply for quality assurance.

A small sample of prepreg can be checked with a dielectric sensor before layup and compared to what is expected. Adjusting the cure for the material status on that day may increase the usability window of the material, reducing waste [25]. A case study is included in Chapter 6.

### 1.7.2.2 Defect tolerances

It is far from easy to lay up a part without any defects occurring. An AFP machine will leave a slight gap between strips of prepreg or overlap them slightly. A foreign object- such as a speck of dust or a sliver of backing paper- can accidentally be stuck to a ply and end up inside the part. A human laminator, even a very good one, will find it difficult to position each ply to sub- millimetre accuracy. Trapped air can form voids, corners can accidentally become folded over, and in more complicate parts it can be difficult to make the stiff prepreg form the detailed shape required. Sometimes the geometry of the part means gaps and overlaps are unavoidable, such as shown in Figure 1.12, where tows are laid up over a curved hemisphere. The curvature means straight lines of fibre cannot be laid up without defects. [4], [26]

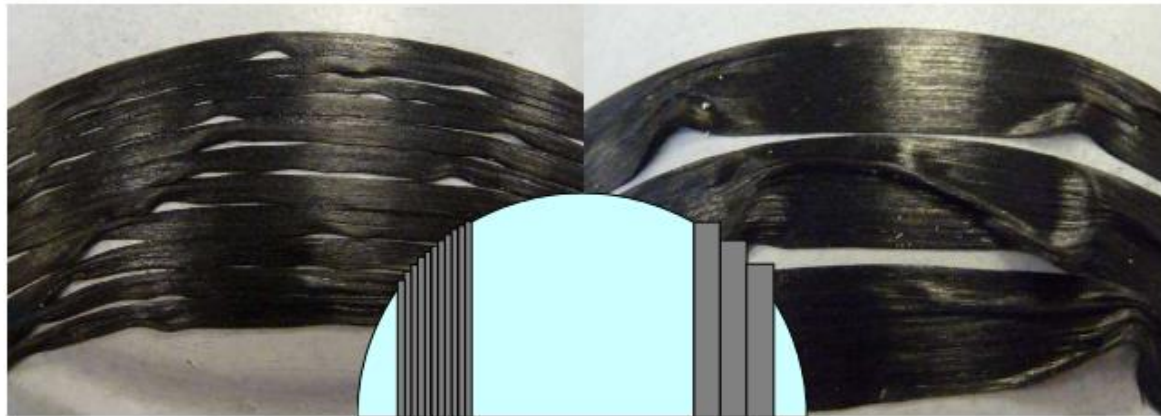

Figure 1.12: Automated Fibre Placement type tapes placed on a curved hemisphere. Reproduced from [26].

The ability to track a defect through the cure process could, in theory, contribute to defining manufacturing tolerances. It is vital that we do not allow anything potentially dangerous to go into service- and also important to reduce our carbon footprints, not to mention wastage of time and money, by not scrapping that which would have been safe to use.

To find out what actually happens to these small scale defects as the cure progresses, we turn to XCT Scanning. CT scans to track composite cure usually involve making multiple samples and quenching them- often with a quick application of liquid nitrogen- to stop cure at different stages during the process[27], [28]. As it is difficult to manufacture identical defects, and the quenching process may affect the result, we chose to develop a technique for In-Process XCT Scanning of composite samples during the cure, so a single test part with a deliberately created defect can, for the first time, be tracked through the cure. This is detailed, along with the results for AFP-style defects, in Chapter 4.

## XCT Scanning

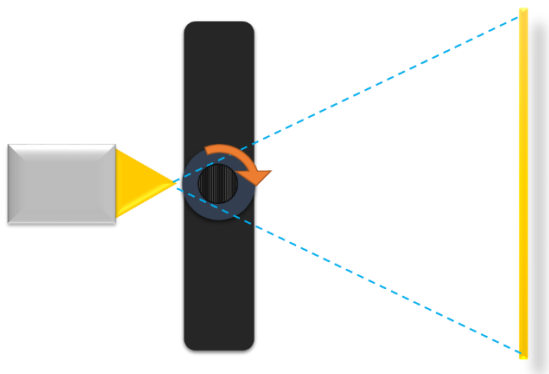

Figure 1.13: Micro X-ray Computed Tomography Scanning

In an industrial CT scanner, the source and detector are fixed while the sample rotates through 360 degrees and X-ray images are taken. These are then reconstructed with image processing software into a 3D volume, where the sample and its interior features can be analysed. A greater number of images produces a better quality 3D volume, with small features visible. The longer the exposure of each image, the less noisy that image is likely to be, as cosmic rays and other random noise are overwhelmed by the photons collected in the projected X-ray image. Scans of composite samples often take ~4 hours. However, to capture changes occurring during the cure process, much faster scans must be used, so there is a trade-off between scan time and scan quality.

## 1.8 Knowledge management

These technical challenges have the potential to contribute greatly to improving the efficiency of composites manufacture. However, this can only be achieved if the technologies are used to their full potential by skilled people with the necessary knowledge to get the best from them.

Knowledge management is often considered fluffy. Full of waffle and consultants telling people what they already know. Not. Proper. Science. To be fair, it can be used for those things. But dismissing it at first glance means missing the useful benefits hidden beneath the buzzwords.

It is easy to find problems due to poor knowledge management. When an expert leaves, there is no one left who understands their work- which is vital for that new contract. Purchasing the autoclave was a complete fiasco, it would be preferable to avoid those mistakes next time. A student needs a length of plastic hose and spends hours trying to find where such a thing might be kept, then must find someone with access to that room. There is a cool new technology that could save the business time and money- but it is buried in academic papers that staff cannot access to read.

It is not possible to solve all such knowledge management problems within this work, but a study of industrial and academic organisations in the composites industry is presented in Chapter 3, intended to inform suggestions for industrially focused knowledge transfer to help bridge the gap.

### 1.8.1 Knowledge Transfer in a Business

Efficient knowledge transfer can make a big difference to any business and is particularly applicable to the composites industry, where new technologies and new applications are constantly being developed. An organisation which manages knowledge well solves problems quickly, as relevant information is easy to find and the staff know- or can look up- who the experts are in what area. Well planned, effective knowledge transfer means training staff efficiently, ensuring everyone knows who or where to go to for answers to their questions, and retaining an employee’s knowledge within the business after they leave- by ensuring it has been transferred to others.

#### 1.8.1.1 From Data to Wisdom

The jargon of knowledge management makes distinction between data, information, knowledge and wisdom. There is disagreement on exact definitions. For this work, the following will be used:

Data	Raw data, e.g. numbers output from a measuring device or program
Information	Organised data, that you might draw conclusions from, e.g. Figure 11 tells me the range of the glass transition temperature for that
Knowledge	Combination of information, experience and sometimes skill, existing in a person’s mind. Subdivided into:
Explicit	can be recorded for others to reference. This could for example be a rule of thumb (operating temperature limit should be x degrees below $T_g$ ) or a list of instructions for completing a task- also referred to as Know-How.
Tacit	cannot easily be codified. For example, a footballer may not be able to describe exactly how she puts a penalty into the top-left corner. She does not measure the wind direction and air pressure in the ball or calculate exactly where she should make contact and with how much force. And there is no list of instructions which could enable me to replicate her feat.
Understanding	Knowing Why. If we covered the footballer and ball in sensors we might build a model of the penalty kick and find out why her kicks land in goal.
Wisdom	Use of judgement- developed from experience- to make good decisions.

Table 1.2: Definitions of knowledge management terms

### 1.8.1.2 Information Management

A key part of a knowledge strategy is information management. Recording lessons learned, for example- and importantly, making sure they are read and used. This is discussed in Chapter 3.

### 1.8.1.3 People (with) Skills

A phrase I use repeatedly in presenting knowledge transfer studies is ‘Knowledge has Legs’. In a business, the knowledge you need exists in the minds of your staff. From this perspective, the importance of effective knowledge transfer becomes obvious- if a key person leaves, you do not want their knowledge to walk out of the door with them.

The Knowledge Transfer Study, presented in Chapter 3, combines some well-known tools- with slight modifications- with simple opinion based questions to provide a snapshot of a team or business, showing what works well and what does not, who the key people are, which competencies are available and any obvious gaps.

#### *Quantifying Competence*

One standard tool, often called a skills or competence matrix, involves asking staff members to rate their expertise in topics of interest to the business, usually from 0 to 5. While guidance on what each level means can help, self-rating is unavoidably subject to personal interpretation so cannot be considered an objective measurement. The individual’s personality makes a difference, with some tending to downplay their own competence while others can be over-optimistic about their abilities.

The Engineering Council definition of Competence will be used here:

*“Competence is the ability to carry out a task to an effective standard. To achieve competence requires the right level of knowledge, understanding and skill, and a professional attitude.*

*Competence is developed by a combination of formal and informal learning, and training and experience, generally known as initial professional development. However, these elements are not necessarily separate or sequential and they may not always be formally structured.” [29]*

### 1.8.1.4 Knowledge Networks

A Knowledge Network is a form of social network, often represented as a diagram such as in Figure 1.14. Each node represents a person and the colour or thickness of the lines between them represent the strength of the knowledge transfer. In this instance red nodes are learning from blue nodes- and it can be seen that most team members are represented by both, with learning often going both ways.

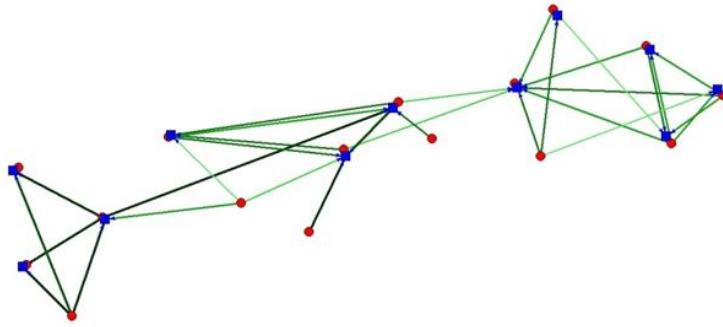

Figure 1.14: A Knowledge Network. Diagram generated using UCInet [30].

There are two main types of knowledge network [31]. A ‘push’ network describes teaching, which might be in a classroom, through a mentoring scheme, on the job or any situation where one person is tasked with imparting knowledge to one or more others. The strength of the link is a representation of how active the learning is, from passive listening to guided experimentation. A ‘pull’ network describes questioning, where the learner chooses to ask a question of someone else. Here the strength of the link represents how frequently one person questions another.

### 1.8.2 The Composites Competency Crisis

One of the key problems currently facing engineering businesses in the UK is shortage of engineers. The Jobs and Growth report [32] from the Royal Academy of Engineering suggests that 28% of the Gross Value Added to the UK economy comes from engineering sectors (2009 figures) and that the UK needs up to 50% more STEM graduates. In the composites field this problem is particularly notable, as the experts who drove the development of the composites industry are now reaching retirement age, while the sector is predicted to grow significantly [2]. It is vital to ensure we do not lose the expertise of the retirees as they head off for relaxation and sunshine. This makes transferring knowledge to the new generation of engineers, and ensuring we make the most of the limited resource these new people represent, particularly vital. Supporting transfers from other areas of science and engineering will be important as well as using links to schools and academia to encourage more students to study STEM subjects and to ensure those that do come away with industry relevant knowledge and skills. [33]

#### 1.8.2.1 Academia to Industry

Linked to this is the importance of knowledge transfer between academia and industry. For a new technology to take hold in the ‘real world’, it must be understood in industrial terms rather than purely academic value and communicated appropriately. Dielectric monitoring of composite cure is a good example, established in academia and just beginning to be used in industry [34]. Chapter 6 is an industry focused resource on this topic.

## 1.9 The National Composites Centre

The National Composites Centre, which hosted and partially funded this research (along with EPSRC), is a High Value Manufacturing Catapult Centre. Its purpose is to develop capabilities for manufacturing of advanced composites, taking basic research from academia and delivering industry suitable demonstrators to member and client companies, as in Figure 1.15. This is an important space, as without something to bridge the gap between academia and industry, many technologies fail. The NCC is owned by the University of Bristol, which is also part of the Composites Future Manufacturing Hub, providing a strong link to academia. Industrial members contribute to funding core research, which is open access, as well as funding specific programmes for their own uses.

This means that enabling and encouraging knowledge transfer from academia to industry is squarely within NCC's remit.

Capability development also refers to training people to work with these technologies in the composites field. This can include apprentices, new graduates and EngD candidates- but also providing training for experienced engineers who do not have experience with composites. Partially funded by the UK government, Catapult centres are intended to support development of industry and hence jobs and economic growth.

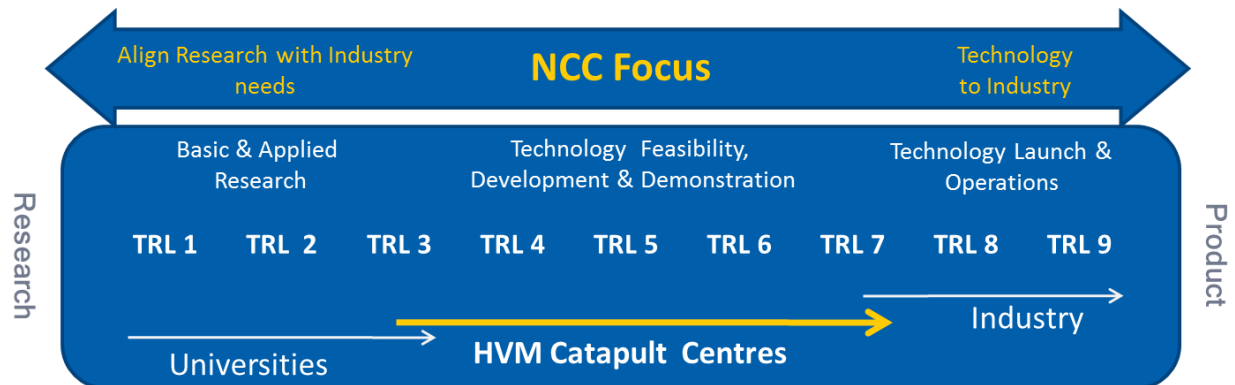

Figure 1.15: The National Composites Centre facilitates technology transfer from academia to industry. [5]

## 1.10 The EngD in Composites Manufacture

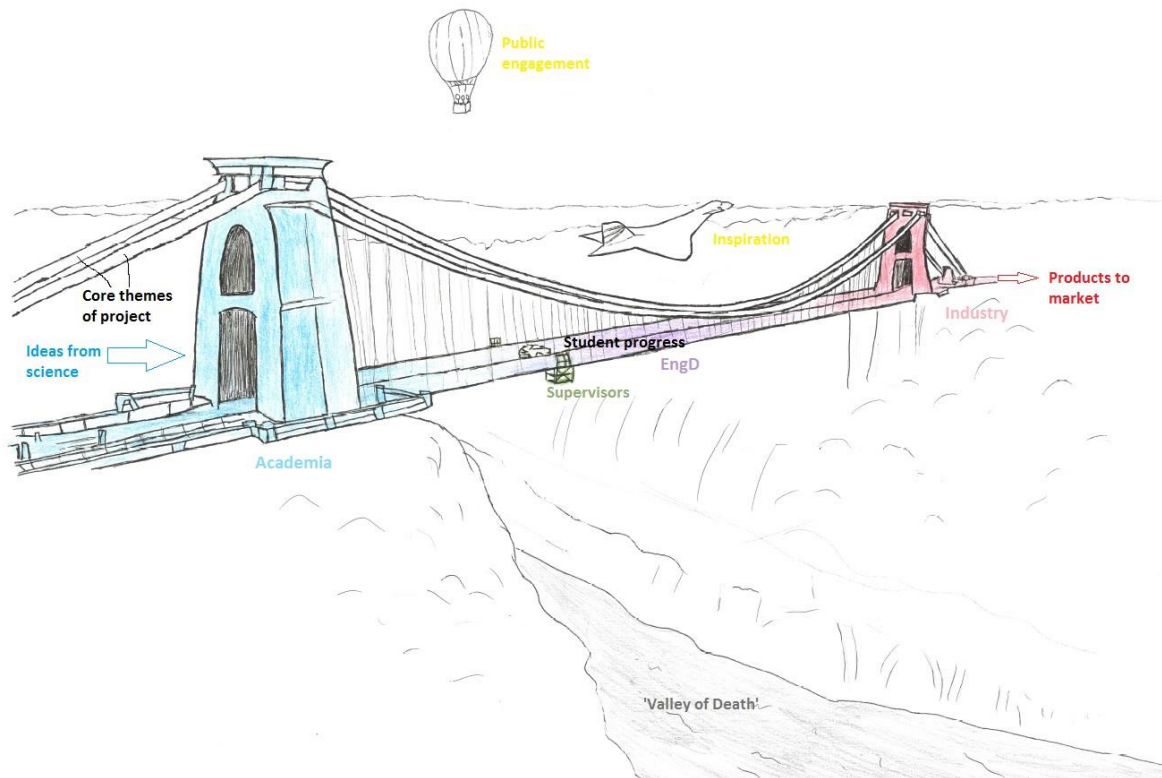

Figure 1.16: Non-Artist's Impression of the EngD

The Engineering Doctorate in Composites Manufacture fits neatly into this theme- and the work done at the National Composites Centre. Aiming to develop ideas from academia and move them into industry- while simultaneously preparing the student for the option of working in industry- it is a cross between a PhD and an industrial research job. The two technologies studied in this EngD fit the theme nicely- but the underlying importance of knowledge transfer is something which might reasonably be considered in all such projects. Our work has far more value if it is easily used.

As this is not a traditional PhD, the thesis is likewise non-traditional. This introductory chapter is intended to make the thesis accessible to those with less familiarity with the subject matter. There are multimedia elements in the appendix. Business concerns must be considered alongside the scientific, and rather than studying one area in depth, a range of topics are brought together- all on the theme of working towards greater efficiency in Composites Manufacture.



# Chapter 2

## 2 Literature Review

### 2.1 Scope

This chapter is intended to provide an overview of topics relevant to the thesis, with sufficient background to facilitate the non-specialist reader's appreciation of both the content and context of the original research presented in this thesis.

The cure of thermosetting resins is key to the experimental campaigns described in Chapters 4 and 5. Cure kinetics models are introduced to provide the necessary background to follow these discussions, and models are described for the two resins used: M21 for tracking of defect evolution using in-process micro-XCT and 8552 for cure cycle optimisation and control with dielectric cure monitoring.

A major focus is in-process monitoring of composites with dielectric analysis, to explain the theoretical basis for the measurements used to track degree of cure in Chapter 5. The equipment used for dielectric analysis (DEA) and the theoretical basis for tracking degree of cure based on the imaginary impedance maximum (versus frequency) of the resin is explained. Industrial applications of the technology are briefly discussed and it is compared to other cure monitoring techniques.

X-ray computed tomography is also used in this thesis, to track defect evolution, as discussed in Chapter 4. Relevant aspects of processing XCT reconstructions and examples of time resolved XCT studies are reviewed here, along with an introduction to the defects studied, tow gaps and ply drops typical of Automated Fibre Placement (AFP) manufacturing.

In order for such technologies to become useful to industry, the practical developments should be accompanied by industrially targeted knowledge transfer, which requires an understanding of both the basic principles of knowledge management and methods used to study knowledge transfer in organisations. A literature review such as this is of course an example of academic codification of knowledge- other approaches may be more suitable in industry. This is discussed at the end of the review in preparation for the knowledge transfer studies presented in Chapter 3 and the suggested knowledge transfer resource for dielectric monitoring which makes up Chapter 6.

Results from both of the in-process monitoring techniques used in this thesis are discussed with reference to the changes in the respective resins during the cure process. It is therefore necessary to begin with a quick explanation of models used to describe the cure.

## 2.2 The Cure Process

Cure of a thermosetting resin is a chemical process, where relatively small molecules and polymer chains react to create large, crosslinked polymer macromolecules. A system with the maximum possible amount of chemical bonds is considered 100% cured- something unlikely to be achieved in practice. The cure process is exothermic.

### 2.2.1 Time-Temperature Transformation diagram

Enns and Gillham's [35] classic time-temperature transformation phase diagram describes the changes which occur during cure, by showing the time required to reach gelation and vitrification (vitrification occurs at the glass transition temperature,  $T_g$ , which changes as the resin cures) for isothermal cure. A version of this diagram is shown in Figure 2.1.

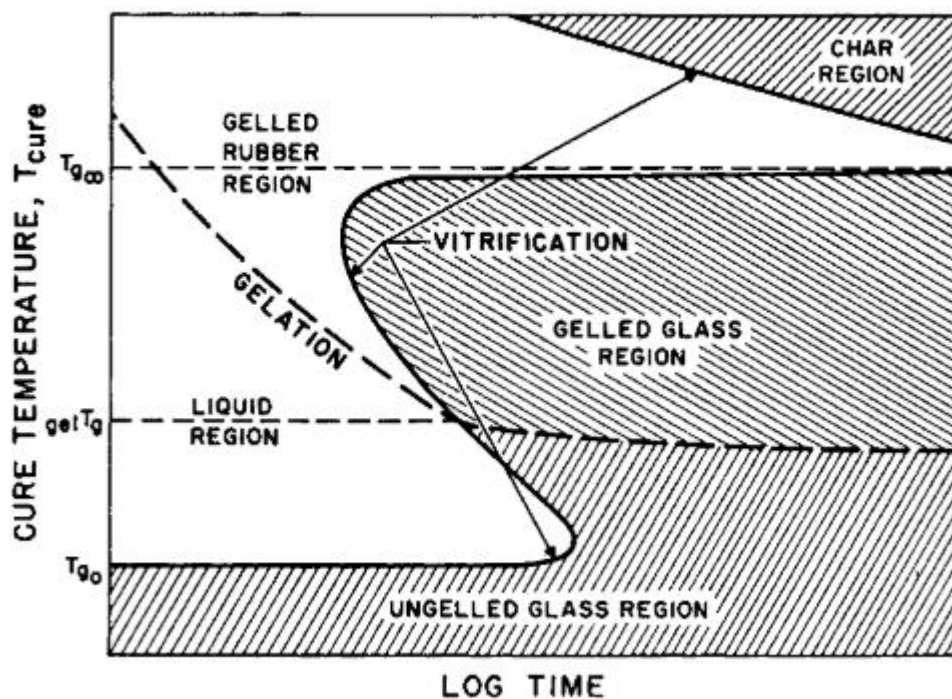

Figure 2.1: Time-temperature transformation diagram. Reproduced from [35]

Isothermal cures are usually between the gel  $T_g$  and maximum possible  $T_{g\infty}$ , to result in a vitrified resin. Beginning in a liquid state, the resin gels then (unless  $T \leq \text{gel}T_g$ ) passes through the rubbery phase before vitrifying.

Once as cured as reasonably possible, without leaving it for an impractical length of time, the resin has a final  $T_g$ . If the cured part is heated above its final  $T_g$  it becomes rubbery, returning to the glassy state when cooled.  $T_g$  is therefore important in determining the usable temperature range of a part.

### 2.2.2 Cure Kinetics

The degree of cure, or chemical conversion, of a resin is considered a measure of how close it is to being maximally cross-linked. It is defined in terms of the heat emitted by the curing reaction. At time  $t$ , the degree of cure  $\alpha$  is given by:

$$\alpha(t) = \frac{\int_{t=0}^t \frac{H}{dt} dt}{H_{total}} \quad (2.1)$$

Where  $H_{total}$  is the total heat emitted during a 'full' cure and  $H$  is the heat released at any time  $t$  [36].

This is the principle used when measuring degree of cure of a partially cured with DSC, where the residual heat of reaction remaining in a partially cured sample,  $H_{res}$ , is measured by curing it the rest of the way, and compared to  $H_{total}$  as measured by fully (to the limit of the equipment) curing a fresh, uncured sample from the same batch.

$$\alpha(\text{sample}) = \frac{H_{total} - H_{res}}{H_{total}} \quad (2.2)$$

Cure kinetics equations are used to model the change in degree of cure as the reaction progresses.

The simplest model is an  $n^{\text{th}}$  order rate equation[37]:

$$\frac{d\alpha}{dt} = K(T)(1 - \alpha)^n \quad (2.3)$$

$K(T)$  is an Arrhenius expression, describing the temperature dependence of the model [38]:

$$K(T) = Ae^{\left(\frac{-E}{RT}\right)} \quad (2.4)$$

Here  $E$  is the activation energy of the reaction,  $R$  the gas constant and  $T$  is temperature, with  $A$  being an Arrhenius constant.

The expressions given in 2.3 and 2.4 are used as a model for an epoxy system with no autocatalysation. Where autocatalysation does occur- that is, products of the reaction act as catalysts, the simplest model is [20], [36]–[38]:

$$\frac{d\alpha}{dt} = K_1\alpha^m(1 - \alpha^n) \quad (2.5)$$

Skordos and Partridge [37] explain that having only a single rate constant  $K_0$  limits the accuracy of the models. Models with two rate constants are often a better fit, similar to the below[36]–[38]:

$$\frac{d\alpha}{dt} = (K_1 + K_2\alpha^m)(1 - \alpha^n) \quad (2.6)$$

The constants  $K_i$  all follow the form of equation 2.4

Karkanias and Partridge [36] found a modification to this model gives a better fit to measured data at the end of the cure for certain resins:

$$\frac{d\alpha}{dt} = K_1(1 - \alpha)^{n_1} + K_2\alpha^m(1 - \alpha^{n_2}) \quad (2.7)$$

In the same paper, Karkanias and Partridge [36] discuss a resin with a cure process involving multiple reactions. Here the overall reaction rate is considered to be a weighted ( $W_i$ ) sum of the individual reaction rates. If each reaction is an  $n^{\text{th}}$  order reaction as in equation 2.3, for  $N$  reactions this is:

$$\left. \frac{d\alpha}{dt} \right|_{\text{total}} = \sum_{i=1}^N W_i K_i (1 - \alpha_i)^{n_i} \quad (2.8)$$

Cure kinetics models for a given resin are defined by fitting one of the above equations to experimental data, commonly from DSC cures.

#### 2.2.2.1 Isothermal degree of cure

Reaction rates can be affected by factors other than bond formation- in particular, if vitrification occurs, diffusion of reactants is far more limited. Modified models, allowing for a limit on degree of cure after glass transition, have been developed, such as the example given by Hubert et al [39].

$$\frac{d\beta}{dt} = (K_1 + K_2\beta^m)(1 - \beta)^n \quad (2.9)$$

$\beta$  is the isothermal degree of cure, the “limiting degree of cure at a given temperature” [39], which is related to  $\alpha$  as follows:

$$\alpha = \beta \frac{H_T(T)}{H_{\text{total}}} \quad (2.10)$$

$H_T(T)$  is the amount of heat which would be given off by curing isothermally at temperature  $T$  for an infinite length of time.

#### 2.2.2.2 Relating degree of cure to $T_g$

The DiBenedetto model [40], based on a description of the degrees of freedom of and interactions between different segments of polymers, relates the change in glass transition temperature as the cure proceeds to the degree of cure [41]. This assumes that the whole resin has a single glass transition temperature at any given moment.

The DiBenedetto equation shown below relates the glass transition temperature  $T_g$ , compared to the glass transition temperature at  $\alpha=0$ ,  $T_{g0}$ , to the degree of cure  $\alpha$ .

$$\frac{T_g - T_{g0}}{T_{g0}} = \frac{\frac{e_\alpha}{e_m} - \left[\frac{F_\alpha}{F_m}\right] \alpha}{1 - \left(1 - \frac{F_\alpha}{F_m}\right) \alpha} \quad (2.11)$$

Here  $F_\alpha/F_m$  is the ratio of mobilities of polymer segments within the resin, for (partially) cross-linked polymers at degree of cure  $\alpha$  and initially, as monomers ( $m$ ). Similarly,  $e_\alpha/e_m$  refers to the ratio of lattice energies for the two states. [41] This can be approximated by:

$$\frac{e_\alpha}{e_m} = \frac{d_m (M_0)_\alpha}{d_\alpha (M_0)_m} \left(\frac{\delta_\alpha}{\delta_m}\right)^2 \quad (2.12)$$

Where  $d$  refers to density,  $\delta$  to solubility parameter and  $(M_0)_m$  is the molecular weight of a monomer and  $(M_0)_\alpha$  the molecular weight of the equivalent unit of a cross-linked polymer. [41]

Enns and Gillham [35] demonstrated a good fit between the DiBenedetto equation and experimental results, also noting the following relationship:

$$\frac{\left(\frac{e_\alpha}{e_m}\right)}{\left(\frac{F_\alpha}{F_m}\right)} = \frac{T_{g\infty}}{T_{g0}} \quad (2.13)$$

Pascualt and Williams [42] set  $F_\alpha/F_m=\lambda$

to put the DiBenedetto equation into the most commonly quoted form:

$$\frac{T_g - T_{g0}}{T_{g\infty} - T_{g0}} = \frac{\lambda \alpha}{1 - (1 - \lambda) \alpha} \quad (2.14)$$

Pascualt and Williams [42] also re-derived the above equation based on changes in heat capacity between the monomers and crosslinked network, supporting its validity.

### 2.2.2.3 Model for Hexcel M21 resin

Chapter 4 reports a study of defect evolution with in-process XCT Scanning was carried out using M21 prepreg. [15] The curing behaviour of M21 as characterised by Kratz et al [43] is referred to in interpretation of the results. This uses the model suggested by Karkanis and Partridge[36], shown in equation 2.7. The parameters for this model were found by fitting to the results from both isothermal and dynamic (fixed rate of temperature increase) scans.

With reference to equations 2.7 and 2.4, the parameters used are shown in Table 2.1. (Dr. James Kratz, pers. comm. 12 May 2017). Figure 2.2 shows the model fit to DSC data for dynamic cure.

Kinetic parameter	Value
A1	420615 [1/s]
E1	78890 [J/mol]
A2	57440 [1/s]
E2	68978 [J/mol]
m	0.61
n1	0.8
n2	3.22

Table 2.1: Cure kinetics parameters for M21 resin, from model by Kratz et al [43]

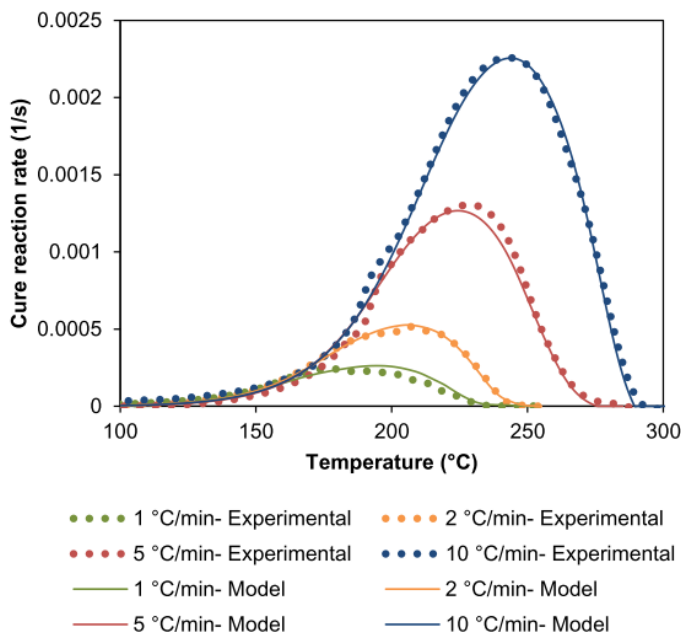

Figure 2.2: Comparison of experimental and theoretical models for cure of M21. Reproduced from [43]

Using DSC data and the DiBenedetto model, Kratz et al found uncured and ultimate glass transition temperatures of  $T_{g0}=1.5^{\circ}\text{C}$  and  $T_{g\infty}=194^{\circ}\text{C}$  respectively, with fitting parameter  $\lambda=0.67$ .

#### 2.2.2.4 Model for Hexcel 8552 Resin

The stepped wedges used for cure cycle optimisation with dielectric monitoring, presented in Chapters 5 and 6, were made from 8552 prepreg. [13] The cure kinetics model used in both the dielectric monitoring and simulation software is the NCAMP model [23], [44]. This model includes both a kinetic contribution,  $\alpha_k$ , and a diffusion contribution,  $\alpha_d$ , to the overall degree of cure:

$$\frac{d\alpha}{dt} = \left( \frac{1}{\frac{d\alpha_k}{dt}} + \frac{1}{\frac{d\alpha_d}{dt}} \right)^{-1} \quad (2.15)$$

The kinetic contribution is itself a sum of two different rates of reaction[23]:

$$\frac{d\alpha_k}{dt} = \frac{d\alpha_{k1}}{dt} + \frac{d\alpha_{k2}}{dt} \quad (2.16)$$

Based on DSC results, the NCAMP model uses the following expressions for the two kinetic components:

$$\frac{d\alpha_{k1}}{dt} = 153900.5e^{\frac{-64929.5}{RT}}(1 - \alpha)^{2.347}(\alpha + 0.1594)^{1.413} \quad (2.17)$$

$$\frac{d\alpha_{k2}}{dt} = 3.963 \times 10^{11}e^{\frac{-133168.3}{RT}}(1 - \alpha)^{1.029}\alpha^{5.586} \quad (2.18)$$

The diffusion component is modelled as:

$$\frac{d\alpha_d}{dt} = 4e^{\frac{-0.21}{4.8 \times 10^{-4}(T - T_g) + b}} \quad (2.19)$$

The parameter  $b$  has three different states. Where  $T_g < 120^\circ\text{C}$ ,  $b=0.021$ .  $120^\circ\text{C} < T_g < 195^\circ\text{C}$ ,  $b$  is linear between 0.021 and 0.031. Where  $T_g > 195^\circ\text{C}$ ,  $b=0.031$ .

The DiBenedetto model is used to relate degree of cure and glass transition temperature, but the NCAMP model does not take into account the known drop in  $T_g$  at high degree of cure due to degradation. This is shown, with the model parameters, in Figure 2.3.

## Glass Transition Temperature

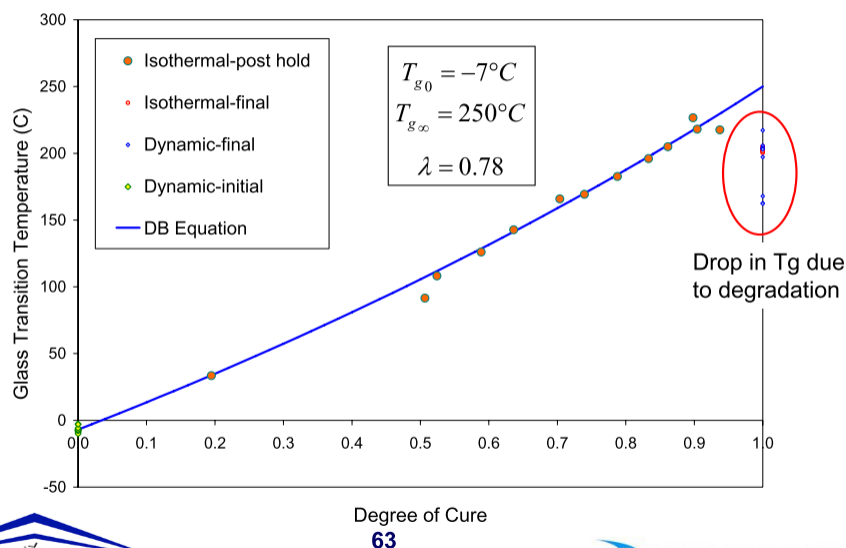

Figure 2.3: NCAMP model for 8552 resin, with parameters for DiBenedetto equation. Reproduced from [23]

## 2.3 In-Process Monitoring in Composites Manufacture

NPL's good practice guide [45] defines cure monitoring as *"a means of tracking the real-time changes in physical state or chemical reaction that occur during the curing process"*. Real time measurements should, in principle, allow changes to be made to the cure process in, either by manual intervention or active process control. Konstantopoulos et al in their 2014 review [46] argue that the main function of this is to minimise production costs, through process optimisation, 'quality upgrade' (defined as working towards eliminating defects) and material characterisation.

All three of these categories are relevant to the work in this thesis, as use of Dielectric Analysis (DEA) for process optimisation is demonstrated- with active process control- in Chapter 5 and the use of the same technique for material characterisation is among the industrial uses of the technique presented in Chapter 6.

Tracking defects, however, requires a different technique. Understanding of their evolution during the cure process can inform design and manufacturing of composite parts. The novel In-Process XCT Scanning method presented in Chapter 4 is applied to this problem for two types of defect typical of Automated fibre placement [47]. It is hoped that a better understanding of defect evolution may, as well as contributing to quality of the final parts, become useful in defining manufacturing tolerances, facilitating process optimisation and hence minimising of costs.

For example, the position and size of voids in the final cured part are shown to be important to the fatigue induced failure of certain samples, intended to be representative of wind turbine blades though with some limitations, in Lambert et al's 2012 paper [48], but this begins with fully cured samples- one cannot draw conclusions about acceptable void sizes at the layup stage or understand how they evolved during manufacture- only during failure.

A variety of sensor technologies are available for tracking material properties during cure- many of which can be used with industrial equipment for composites manufacture. For the case of wind turbine blades in particular, Schubel et al's 2013 review [49] discusses both monitoring of the cure during manufacture and structural health monitoring during the blade's lifespan, concluding that dielectric, acoustic, ultrasonic, thermal and fibre optic strain monitoring methods are feasible.

Konstantopolous et al's aforementioned 2014 review [46] covers the more popular in-process monitoring techniques, shown in Table 2.2. Industrial applicability is mentioned, though the discussion does not use industrial terms such as technology readiness levels. Knowledge transfer between academia and industry is crucial to encouraging technology transfer [50], which will be further discussed in the knowledge management section of this chapter and in Chapter 3.



		Flow front	Curing degree	Void content	Delaminations
Electromagnetic properties	Dielectric analysis (DEA)	✓	✓	✓	✓
	Direct Current (DC) analysis	✓	✓		
	Electrical time domain reflectometry (ETDR)	✓	✓		
Mechanical properties	Optical fiber interferometers (OFI)	✓	✓		
	Ultrasonic transducers	✓	✓	✓	✓
Optical properties	Optical fiber refractometers (OFR)	✓	✓		
	Spectrometers	✓	✓		
Thermo-dynamical properties	Thermometers	✓	✓		✓*
	Pressure transducers	✓			

\*Only by Infrared (IR) thermography

Table 2.2: Table listing popular cure monitoring techniques, reproduced from [46].

The authors consider all of the listed methods save for pressure transducers as suitable for tracking ‘curing degree’. However, they do not consider optical fibre techniques suitable for industrial use due to their fragility. Having connected up both optical fibres and flexible dielectric sensors for cure, the author of this thesis respectfully disagrees. Care is required during layup and for everyday industrial usage ruggedised connectors will be needed, in both cases, but this is certainly possible.

Optical fibres are however more commonly used for tracking strain using Fibre-Bragg Gratings. While spectroscopic techniques for tracking degree of cure can in principle be carried out using optical fibres, comparisons to other cure monitoring techniques such as DEA are more frequently made with laboratory based spectroscopes [38], [51]. This work is restricted to tracking the progress of the cure rather than mechanical properties such as strain. The cure monitoring aspect focuses on Dielectric Analysis (DEA). DC resistance cure monitoring sensors were also tested.

## 2.4 Dielectric Analysis (DEA) for Cure Monitoring

A dielectric sensor consists of two electrodes placed in contact with the resin or the area it will flow into. The resin completes an alternating current circuit. As the charge on the electrodes alternates, the species which make up the resin respond to this. Varying the frequency of the sinusoidal voltage results in a spectrum of responses, as different effects dominate at different frequencies [17]. This is also called dielectric spectroscopy [52] or impedance spectroscopy [53]. As the cure progresses, the chemical composition of the resin changes, so changing the resin response. Commercial systems for dielectric analysis exist [34], [54]–[57], some research groups also develop their own [58].

Pethrick and Hayward’s 2002 review [59] details some other applications of dielectric analysis, along with cure monitoring. One of these is to study water absorption [60]–[63], a potential structural health monitoring application for embedded sensors remaining in parts during their service lifetime. Raihan et al [62] have used dielectric spectroscopy during mechanical tests.

### 2.4.1 Sensor technologies

There are broadly two ways in which the dielectric properties of resins are measured- by electrodes, either parallel plate or interdigitated, in a circuit as described above; and by microwave cavity.

#### 2.4.1.1 Microwave cavity

Included for disambiguation only- it is possible to measure the dielectric properties of a material by the shift in resonant frequency of a microwave cavity [64], [65] and to use this to track the cure. This is impractical for most industrial processes, though it may be of use where microwave cure is used or on pultrusion lines.[66]. The microwave cavity method has not been used in this work.

#### 2.4.1.2 Parallel plate electrodes

The parallel plate method preceded smaller interdigitated sensors [19] for dielectric analysis of both resins and composites. Self- contained laboratory instruments for dielectric analysis, widely used for study of resins[38], [67]–[72], often use either this setup or a variation with a cylindrical capacitor for the electrodes [73].

Parallel plate electrodes, unlike interdigitated sensors, measure the bulk properties of the material, as the electric field passes between the electrodes through the thickness of the sample or, theoretically, part. This can be considered an advantage over interdigitated electrodes, which measure only a small distance inside the composite part.

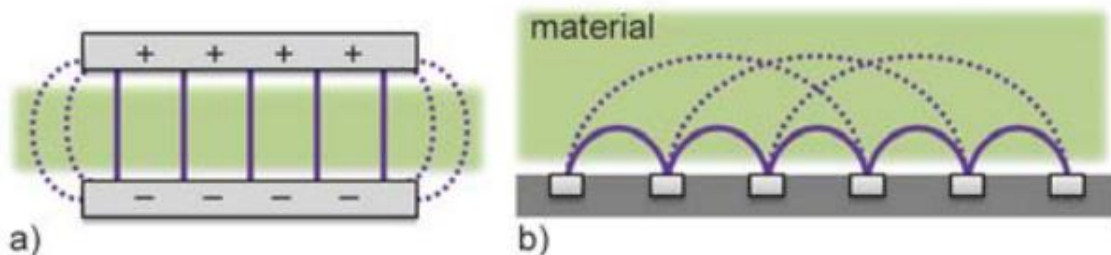

Figure 2.4: (a) Parallel plate electrodes, with electric field through the whole sample, and (b) interdigitated electrode with fringing electric field. Reproduced from [46].

Parallel plate electrodes have been suggested for Resin Transfer Moulding (RTM) as the process involves a closed mould, as shown in McIlhagger et al's paper [74], reproduced as Figure 2.5. This team have used a laboratory based parallel plate dielectric analysis system to approximate the RTM process for both glass fibre [75] and carbon fibre [74] reinforced parts, though they choose only a single frequency for each part and report measurements of the ionic conductivity and derived items only, rather than complex permittivity or impedance.

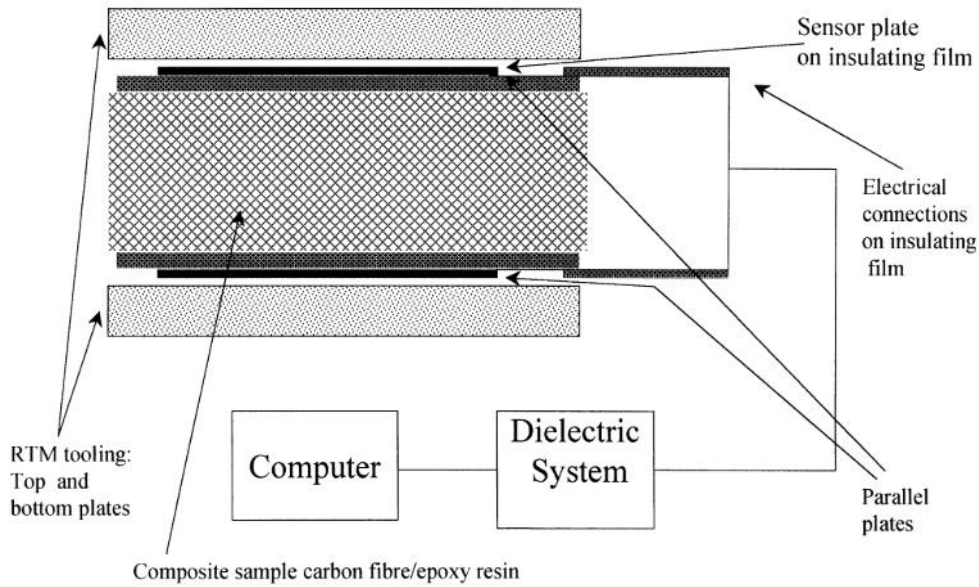

Figure 2.5: Parallel plate sensors for Resin Transfer Moulding. Reproduced from [74]

However, a major problem for the use of this method during manufacture is the requirement for the sensor geometry- electrode dimensions and separation- to be known and to either remain consistent or be re-calibrated if something changes. The capacitance and resistance of the parallel plate setup depends on the area of the plates,  $A$ , separation,  $D$ , frequency of the sinusoidal voltage,  $f$ , permittivity of free space,  $\epsilon_0=8.85 \times 10^{-2} \text{F/m}$ , as shown below [75].

$$C = \frac{\epsilon' \epsilon_0 A}{D} \quad (2.20)$$

$$R = \frac{D}{2\pi f A \epsilon'' \epsilon_0} \quad (2.21)$$

$\epsilon'$  is the relative permittivity of the material under test and  $\epsilon''$  is the dielectric loss factor. These are the components of complex relative permittivity. They change during the cure and can hence be used to track its progress, as detailed further on. Keeping these dimensions constant is difficult as during a cure the distance between the top and bottom plates may change as pressure is applied to the part.

Kobayashi et al [76] have tested a sensor system consisting of two flexible grids of electrodes, to be placed on either side of a closed mould. Measurements are taken using pairs of electrodes, which are used to visualise the degree of cure over the whole part, showing variation across the area of the part- though of course not through the thickness.

Where the part is not cured in an enclosed mould or press, parallel plate sensors are not suitable.

### 2.4.1.3 Interdigitated sensors

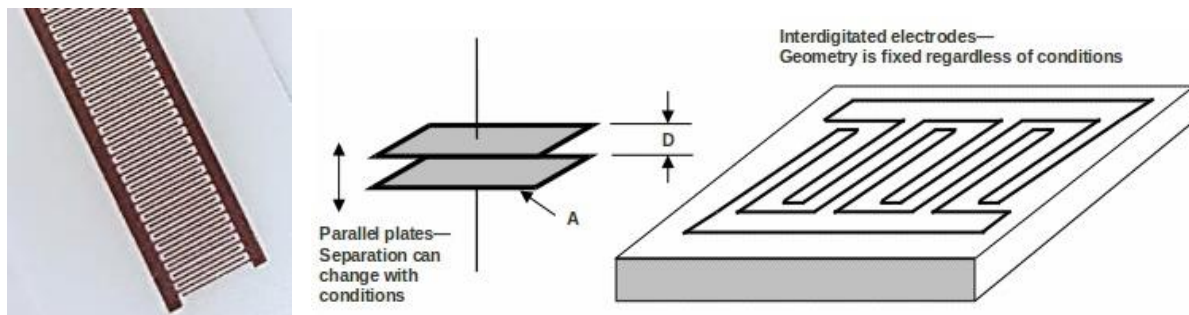

Figure 2.6: Flexible electrode. Figure 2.7: Parallel plate and interdigitated electrodes. Reproduced from [77]

The development of small interdigitated electrodes (also called IDEX or comb electrodes) for use in dielectric analysis ensured that the electrode geometry could be kept constant [19], [78], [79], as shown in Figure 2.7. Spacing between parallel plates may change with temperature or applied pressure, but a fixed geometry means the system does not need to be continually re-calibrated during the cure. Modern interdigitated sensors can be built into moulds or embedded within a part and can be used with manufacturing equipment such as autoclaves, ovens, presses and moulds.

Unlike the parallel plate electrodes, the electric field is restricted to a region close to the sensor. To track cure throughout a part, multiple sensors must be used. The electric field penetrates a small distance into the resin, sufficient to monitor cure through a thin layer of another substance such as release agent or thermoplastic [80].

Figure 2.8 shows the penetration of this fringing electric field into the composite material under test, showing field penetration of 1.2 times the distance from the centre of one electrode to the next [17]. Yang et al [81] measured the increase in capacitance as the thickness of the dielectric was increased. They found that above a thickness of  $0.6D$  the rate of increase of the capacitance decreased, estimating the practical limit of sensitivity on their sensors as a thickness of resin equal to  $D$  (in their paper,  $\lambda=2D$ ). This is a little less in practise than the  $1.2D$  suggested by Partridge and Maistros [17], whose diagram resembles the theoretical calculations of Van Gerwen et al [82].

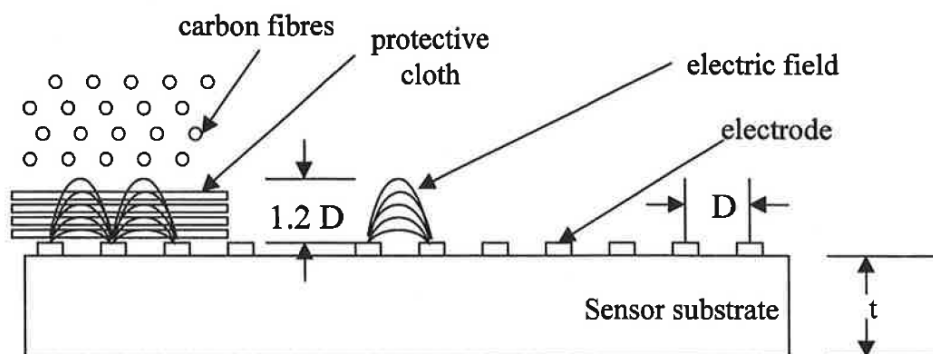

Figure 2.8: Penetration of fringing field into test material. Reproduced from [17]

Where conductive reinforcement such as carbon fibres are used, it is necessary to protect the sensor electrodes in order to prevent shorting by the conductive fibres. This is commonly done with glass fibre cloth and some commercially available flexible sensors, such as NETZSCH's Kapton based sensors (used in Chapter 5), are sold with an integrated glass fibre veil[56].

The spacing of the electrodes affects the depth to which the field penetrates. This can be important where a layer of release agent or surface coating sits between the sensor and the resin, such as the thermoplastic layer placed between sensors and resin by Meier et al [80], who found the dielectric sensor had sufficient penetration to track the cure despite this. Interdigitated sensors integrated into the tool or mould are most likely to require this extra penetration, as such surface layers are not likely to be used around embedded flexible sensors.

Kim and Lee [83] investigated different geometries for interdigitated sensors and found a rectangular spiral had a larger capacitance than a simple interdigitated comb. Two vendors [56], [57] offer tool mounted sensors with circular spirals, but rectangular options could not be found.

#### *Tool mounted sensors*

Re-usable sensors designed for mounting in tool surfaces, such as that shown in Figure 2.9 are commercially available from a variety of manufacturers[34], [54], [56], [57]. These are sealed units which should be mounted flush with the tool surface. Tool mounted sensors are significantly more robust than flexible sensors but can only track the cure near to the surface of the part.



Figure 2.9: A sensor designed for mounting in a tool surface.



Figure 2.10: A resin cell in use

#### *Resin cell*

The same re-usable sensors can be mounted in a small heater cell for analysis of samples of resin or prepreg in a laboratory, as shown in Figure 2.9: A sensor designed for mounting in a tool surface.

Figure 2.10.

### Flexible sensors

Flexible sensors, designed to be embedded in a part, are commonly used in research [17], [20], [84]–[89]. These sensors can be placed anywhere in a part and are cured in place. In a production part the effect of the sensors on the structural properties of the part may be a problem, however they can be useful in the development stage, or can be restricted to use in areas where the sensors' presence is not a problem.

While referred to in this document as 'flexible', it should be noted that Polanský et al [90] have created small (5.3mm x 8.6mm) interdigitated sensors on a ceramic substrate and embedded them between layers of braided glass fibre before infusion, using the sensors to monitor the cure. The sensors were embedded in an area intended to be cut off, avoiding defects in the final part.

Typical gap sizes between electrodes are  $\sim 100\mu\text{m}$  in flexible sensors [91], as in Figure 2.11.

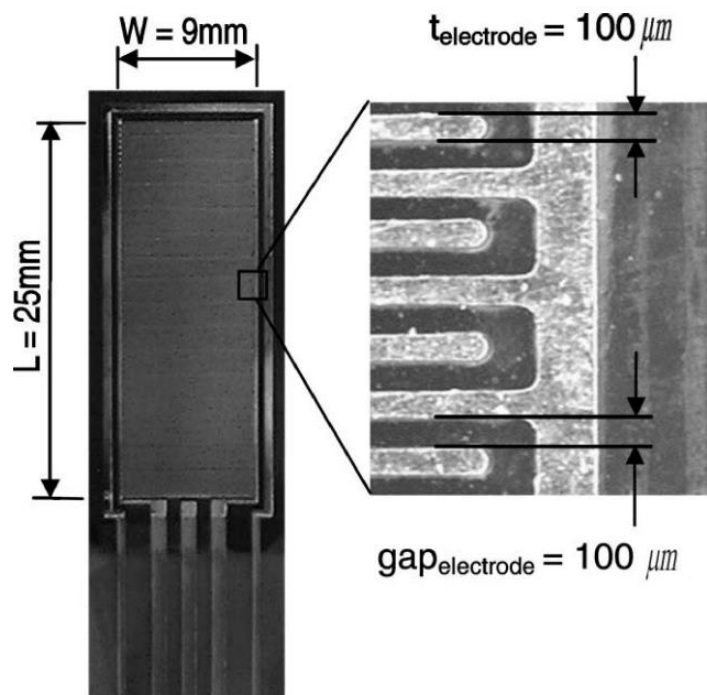

Figure 2.11: Flexible interdigitated electrode (Lacomtech, Daejeon, Korea). Reproduced from [91]

Yang et al [81] have been working on optimisation of sensor geometry. They suggest that where the smallest achievable feature size is  $100\mu\text{m}$  (Figure 2.11), the gap size and electrode width each should be  $100\mu\text{m}$ ; with finger length of 15mm and 60 fingers. It is unclear whether '60 fingers' means 60 in total or 60 per electrode. Sensors of this type typically have a thickness of  $\sim 150\mu\text{m}$  or more [92].

Boll et al [92] suggest that smaller sensors could be cured into production parts without structural problems. They produced 5 $\mu\text{m}$  thick sensors with a 3 $\mu\text{m}$  electrode width and gap and a 1 $\mu\text{m}$  protective film. The sensors are used to track ion viscosity, showing clear signals but with no independent comparison. In a later paper [93] the same team compared two similar sensors, this time with gap width= electrode width of 5 $\mu\text{m}$  and 10  $\mu\text{m}$ , to a standard IDEX as shown in Figure 2.12. The microscale sensors were used at different sinusoidal voltage frequencies to the standard sensor. It would be preferable to see a comparison across a range of frequencies and comparison of the microscale sensor results to DSC measurements as a fully independent check.



Figure 2.12: Comparison of standard and microscale sensors (smallest scale is mm). Reproduced from [93]

The smaller depth of penetration of the electric field means these sensors are unlikely to detect cure if there is a surface layer between them and the resin as in Meier et al's work [80], but this is less likely to be a common application for an embedded sensor.

#### 2.4.2 Resin Response to Sinusoidal Voltage

A sinusoidal voltage of angular frequency  $\omega=2\pi f$  is applied across the electrodes. The response of the resin is commonly analysed in terms of the *complex permittivity*  $\epsilon^*=\epsilon'-j\epsilon''$ .  $\epsilon'$  can be called real permittivity [94], dielectric permittivity, just 'permittivity' or dielectric constant.[79], [95], [96]  $\epsilon''$  is known as dielectric loss (factor)- as this quantifies dissipation of energy. [79], [95], [97], [98]  $\epsilon'$  and  $\epsilon''$  are hereafter referred to as *relative permittivity* and *dielectric loss* respectively.

This should not be confused with the *loss tangent* of the material between the electrodes, which is defined as the ratio of dielectric loss to relative permittivity, so the *loss angle*,  $\delta$  is the *argument* of  $\epsilon^*$  in the complex plane.

$$\tan \delta = \frac{\epsilon''}{\epsilon'} \quad (2.22)$$

As the resin contains a mixture of different species, the response to the electric field has more than one component. It involves a combination of at least three factors- *electrode polarisation*, *charge migration* and *dipolar relaxation*[99], [100]. In heterogenous systems *interfacial polarisation* can also occur[52], [94].

#### 2.4.2.1 Electrode polarisation

This is blocking of electrodes by ions of opposite charge to the electrode. In effect, it adds capacitance to the system[96], affecting experimental measurements.

Day et al [96] showed that for an electrode spacing  $D$  with electrode polarisation causing a blocking layer of thickness  $d_b$  at each electrode, where the complex permittivity in the blocking area is the same as in the rest of the resin, the experimentally measured relative permittivity  $\epsilon'_{el}$  and dielectric loss  $\epsilon''_{el}$  are related to the relative permittivity  $\epsilon'$  and dielectric loss  $\epsilon''$  of the material between the electrodes as follows[101]:

$$\epsilon'_{el} = \epsilon' \frac{D}{2d_b} \frac{\left(\frac{\epsilon''}{\epsilon'}\right)^2 + \frac{D}{2d_b}}{\left(\frac{\epsilon''}{\epsilon'}\right)^2 + \left(\frac{D}{2d_b}\right)^2} \quad (2.23)$$

$$\epsilon''_{el} = \epsilon'' \frac{D}{2d_b} \frac{\frac{D}{2d_b} - 1}{\left(\frac{\epsilon''}{\epsilon'}\right)^2 + \left(\frac{D}{2d_b}\right)^2} \quad (2.24)$$

Electrode polarisation requires free ions able to move between the electrodes, thus it contributes more to the signal early in the cure when cross-linking and hence viscosity is low, and is particularly notable at low frequencies. [96] Kazilas [94] shows the effect of the order of magnitude of the ratio  $D/2d_b$  on the ratios  $\epsilon'_{el}/\epsilon'$  and  $\epsilon''_{el}/\epsilon''$ . As  $2d_b \rightarrow D$ ,  $\epsilon'_{el}/\epsilon'$  shows an increase while  $\epsilon''_{el}/\epsilon'' \rightarrow 0$ . This should be borne in mind when assessing extremely small electrode gap sensors such as those mentioned previously [93], [102].

Maistros and Bucknall suggest that in practical circumstances the contribution of electrode polarisation to the dielectric loss is negligible, but find a notable contribution to the relative permittivity at low frequencies during the early part of the cure. [95].

Electrode polarisation is often neglected[103] when assessing charge migration and dipole relaxation[104], but should be considered at least in regards to the relative permittivity, in the early part of the cure and lower frequency region particularly. [18], [95], [105]



#### 2.4.2.2 Charge migration

Any charged species which can move between the electrodes, forming a current, contributes to conduction by charge migration. Maistros and Bucknall [104] and Garden et al [106] among others attribute conduction only to ionic impurities in the resins, however charged species which form during the polymerisation reactions may also contribute to this while available [68], [94], [107]. The conductivity due to migrating charged species,  $\sigma_{cm}$  is a sum of the conductivities of all the freely mobile charged species at the time the measurement is taken.

As a dissipative process, charge migration- also called ion conduction [38], [71], [108]- affects only the dielectric loss component of the complex permittivity of the resin, as shown below[94].

$$\epsilon'_{cm} = 0 \quad (2.25)$$

$$\epsilon''_{cm} = \frac{\sigma_{cm}}{\omega\epsilon_0} \quad (2.26)$$

#### 2.4.2.3 Dipole relaxation

The two classes of dipoles- static and induced- respond differently to the alternating current.

##### *Induced dipoles*

Species which, when not exposed to an electric field, have zero dipole moment can be polarised by the field. The movement of the electron cloud is sometimes referred to as electronic polarisation [95], [101]. The response time to the change in electrode polarity is far faster than the frequencies used in dielectric cure monitoring, so induced dipole polarisation is considered frequency independent [101]. Atomic polarisation refers to deflection of constituent atoms in a molecule from their equilibrium position and, along with electronic polarisation, has a low dielectric loss in the frequency range used for dielectric monitoring [109].

##### *Static dipoles*

Static or permanent dipoles respond to an applied electric field by orientating themselves to align with it. These may be individual molecules or parts of a larger molecule, including polymer chains. As the electric field oscillates, the dipoles re-orientate in response.

The Debye model, for a single species of spherical dipole with a single *relaxation time*  $\tau$ , is described by Senturia and Sheppard as “the simplest model of hindered dipole orientation”[79]. Here  $\epsilon_u$  is unrelaxed permittivity, seen at high frequencies, and  $\epsilon_r$  is relaxed permittivity, seen at low frequencies. Debye complex permittivity is written as [52], [94], [109]:

$$\epsilon^*_{sd} = \epsilon_u + \frac{(\epsilon_r - \epsilon_u)}{1 + j\omega\tau} \quad (2.27)$$

This results in relative permittivity and dielectric loss components as shown below:

$$\epsilon'_{sd} = \epsilon_u + \frac{(\epsilon_r - \epsilon_u)}{(1 + \omega^2\tau^2)} \quad (2.28)$$

$$\epsilon''_{sd} = \frac{(\epsilon_r - \epsilon_u)\omega\tau}{(1 + \omega^2\tau^2)} \quad (2.29)$$

As this model describes only a single species of dipole, and resins may contain many dipole species, various generalisations of the Debye model have been developed to allow for this, including the Cole-Cole model [110], as used by Maistros and Bucknall [95] to model dipole relaxation in their experimental work on dielectric cure monitoring of epoxy resin blends, which describes a symmetrical distribution of relaxation times. Alternatives include the Havriliak-Negami model, for a skewed distribution, as used by Nixdorf and Busse[103].

As pointed out by Senturia and Sheppard [79], during the cure process the relaxation time distribution should be expected to change. Both the relaxed permittivity and model parameters are expected to change with degree of cure, thus *to characterise the relaxation time distribution one must measure relative permittivity and dielectric loss across a range of frequencies.*

#### 2.4.2.4 Interfacial polarisation

Occurring only in resins containing more than one phase, such as a thermoset with thermoplastic particles, the interface or boundary between two phases can become polarised. This is discussed in detail by Asami [52], who covers a variety of different heterogenous systems.

Like dipole polarisation, this is described with a relaxation as the polarisation lines up with the electric field. A two phase system- such as one variety of particles embedded in a homogeneous matrix- can hence be described by the Debye model as in equations 2.27-2.29. [18], [94], [111]

As described by MacKinnon et al [111], a two phase system with ellipsoids of conductivity  $\sigma_2$  and permittivity  $\epsilon_2$  in a matrix of conductivity  $\sigma_1$  and permittivity  $\epsilon_1$ , where the volume fraction of ellipsoids is  $v_2$ , has unrelaxed permittivity  $\epsilon_u$  and relaxed permittivity  $\epsilon_r$  as follows:

$$\epsilon_r = \epsilon_1 \frac{\sigma_1[A_a(1-v_2)+v_2](\sigma_2-\sigma_1)}{\sigma_1+A_a(1-v_2)(\sigma_2-\sigma_1)} + v_2\sigma_1 \times \frac{\sigma_1+A_a(\sigma_2-\sigma_1)(\epsilon_2-\epsilon_1)-[\epsilon_1+A_a(\epsilon_2-\epsilon_1)](\sigma_2-\sigma_1)}{[\sigma_1+A_a(1-v_2)(\sigma_2-\sigma_1)]^2} \quad (2.30)$$

$$\epsilon_u = \frac{\epsilon_1 + [A_a(1 - v_2) + v_2](\epsilon_2 - \epsilon_1)}{\epsilon_1 + A_a(1 - v_2)(\epsilon_2 - \epsilon_1)} \epsilon_1 \quad (2.31)$$

Here  $A_a$  is the depolarisation factor along the a axis of the ellipsoid [111], which is 1/3 for spheres[112]. The relaxation time is:

$$\tau_{MWS} = \epsilon_0 \frac{\epsilon_1 + A_a(1 - v_2)(\epsilon_2 - \epsilon_1)}{\sigma_1 + A_a(1 - v_2)(\sigma_2 - \sigma_1)} \quad (2.32)$$

Interfacial polarisation, as it only occurs in resins with more than one phase, can be used to identify phase separation during the cure. For example, Maistros et al [18] identified a peak in relative permittivity for a resin system containing a rubber additive that was not seen in the same resin without the rubber, thought to be due to interfacial polarisation caused by phase separation.

#### 2.4.2.5 Combining the signals

The theoretical models discussed above can be used to isolate a particular facet of the resin behaviour- for example, Nuñez et al [71] subtract the charge migration component in order to study dielectric relaxation in their test resin. Taken together, they provide a lot of information on the behaviour of the resin during cure. Maistros and Bucknall [104] presented a model which shows each component separately, before combining them together and comparing to experimental data for their resin and blend with 15% additive particles (causing interfacial polarisation). For clarity on each contributing factor, the reader is encouraged to read their paper.

Their experimental results are reproduced and annotated in Figure 2.13. The annotations point out only the clearest feature of each contributing factor to the overall dataset. For the resin with additive particles, interfacial polarisation makes dipole relaxation features harder to distinguish. Charge migration contributes throughout, but the linear relationship between  $\epsilon''$  and frequency at the start of the cure is most notable. Electrode polarisation is seen at low frequency and early in the cure in  $\epsilon'$ , also affected by the presence of the additive.

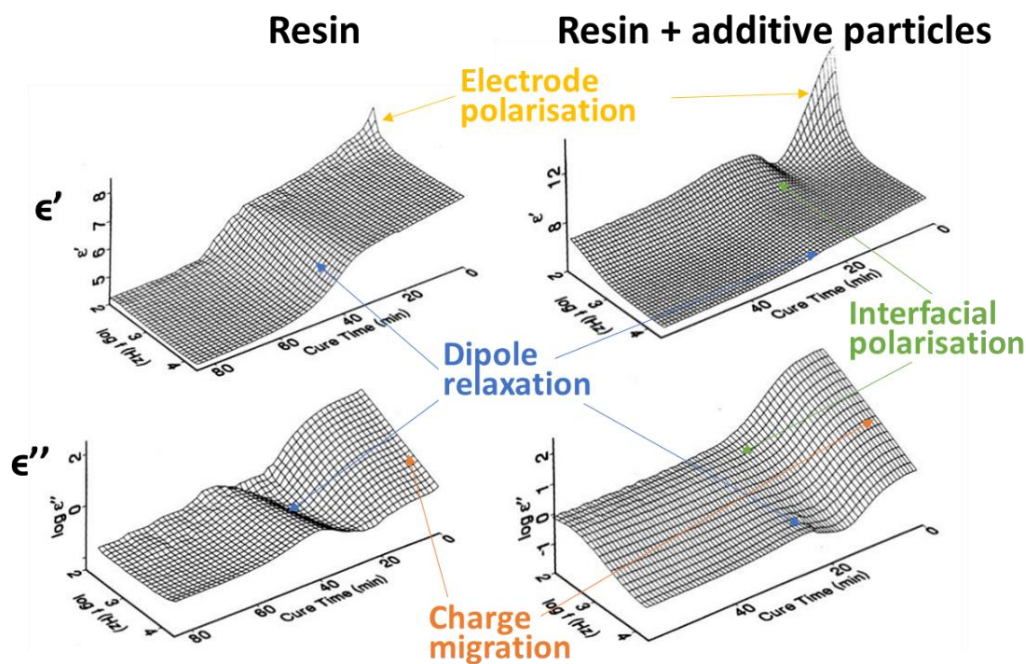

Figure 2.13: Relative permittivity and dielectric loss during the cure of an epoxy resin. Graphs reproduced from [104]. Titles and annotations, showing the clearest feature of each contributing factor, added here.

### 2.4.3 Equivalent Circuit Analysis

A common alternative to measuring relative permittivity and dielectric loss is to model the resin+electrode system using resistance and capacitance elements in an electrical circuit [88], [100], [109]. The complex impedance of the system is measured and interpreted in terms of the equivalent circuit. This is introduced in some detail by Bellucci et al as part of a series of three papers [67], [98], [100] and demonstrated by Mijović and Yee [68] from the same group.

Complex impedance is inversely related to complex permittivity:

$$Z^* = \frac{1}{j\omega C_0 \epsilon^*} \quad (2.33)$$

Where  $C_0$  is the capacitance of the dielectric sensor system in air.[94] The equivalent to a Cole-Cole plot for impedance is a Nyquist plot (imaginary versus real components of complex impedance[68]).

For a system with only one static dipolar relaxation and no interfacial polarisation, an equivalent circuit represents the contributions to the impedance from electrode polarisation, charge migration, induced dipoles and static dipoles as shown in the commonly used representation in Figure 2.14.

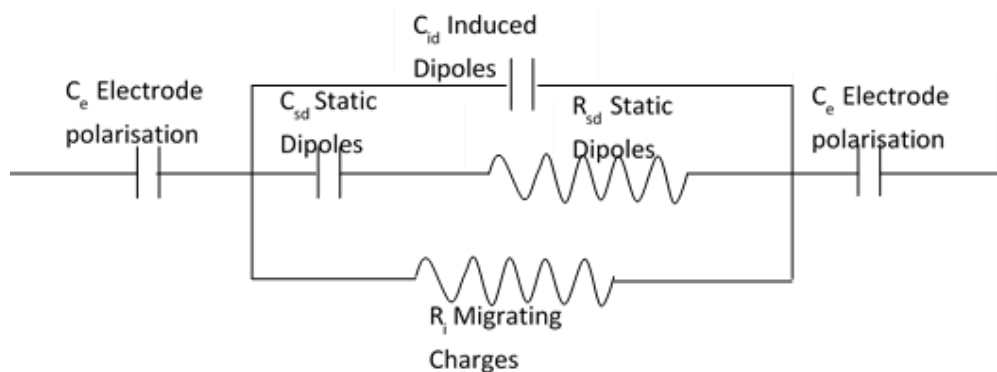

Figure 2.14: Equivalent circuit representation of electrodes and resin in a system with a single static dipole relaxation and no interfacial polarisation. Based on [88]

Electrode polarisation is modelled as a capacitor at each electrode representing the blocking layer of charges, each of capacitance  $C_e$ , in series with all the other components of the resin behaviour. Conduction via migrating charges (often called ion conduction) is modelled by the resistor  $R_i$ . This acts in parallel with dipole relaxation. Induced dipoles, responding effectively instantaneously compared to the frequency of the sinusoidal voltage variation, can be modelled as a capacitance only,  $C_{id}$ . Static dipoles which must re-orientate themselves to align with the electric field as it changes, are represented by a capacitor  $C_{sd}$  and resistor  $R_{sd}$ . Where there is more than one dipolar relaxation time, for example due to a variety of different static dipolar species being present, a parallel link with a capacitance and resistance is required for each species. [68], [88], [94], [100]

For the circuit shown, the real and imaginary components of the complex impedance are described by the resistances and capacitances present [37]. Here  $C_{id}=\epsilon_u C_0$  and  $C_{sd}=(\epsilon_r-\epsilon_u)C_0$ .

$$Z' = \frac{R_i[\omega^2 C_{sd}^2 R_{sd}(R_{sd} + R_i) + 1]}{\omega^2(C_{sd}R_i + C_{sd}R_{sd} + C_{id}R_i)^2 + (\omega^2 C_{sd}R_{sd}R_i C_{id} - 1)^2} \quad (2.34)$$

$$Z'' = \frac{R_i[\omega^3 C_{sd}^2 R_{sd}^2 R_i C_{id} + \omega R_i(C_{id} + C_{sd})]}{\omega^2(C_{sd}R_i + C_{sd}R_{sd} + C_{id}R_i)^2 + (\omega^2 C_{sd}R_{sd}R_i C_{id} - 1)^2} + \frac{2}{C_e \omega} \quad (2.35)$$

Following this model, the relationship between the components of complex impedance and frequency can be split into three zones as shown in Figure 2.15.

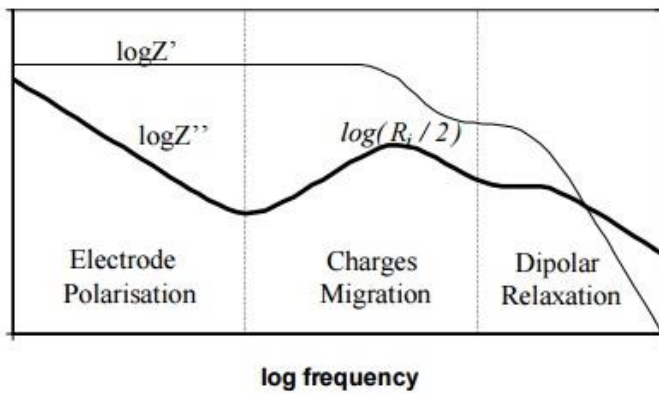

Figure 2.15: Illustration of  $\log Z'$  and  $\log Z''$  versus  $\log$  frequency, 3 zones of the cure. Reproduced from [88].

At very low frequencies electrode polarisation dominates. In the second zone where electrode polarisation does not affect the signal and charge migration dominates, the capacitance of the polymer is modelled as  $C=C_{id}+C_{sd}$ . Here an approximation of  $Z''$ , in this region only, is:

$$Z''_{zone2} = \frac{\omega C R_i^2}{1 + \omega^2 C^2 R_i^2} \quad (2.36)$$

The peak of  $Z''$  is where the derivative of  $Z''$  with respect to  $\omega$  is zero. This occurs where  $\omega=1/R_i C$ . Therefore, the peak of  $Z''$  occurs at  $Z''_{peak} = R_i/2$  as shown [68]. So ionic resistance can be measured from the  $Z''$  peak. In the third zone, the effect of dipolar relaxation can be seen.

#### 2.4.4 Using $Z''$ to Track the Cure

The dielectric monitoring equipment used in Chapter 5 calculates degree of cure and  $T_g$  based on a resin model. The equipment can also display  $Z'$  and  $Z''$  versus frequency during the cure.

The  $Z''$  peak moves to lower frequency and higher amplitude with cure, as the crosslinking reactions increase the impedance of the material, as in Figure 2.16 [101]. Electrode polarisation is seen at low frequency and cure time, with the  $Z''$  peak attributed to charge migration used to track cure [101].

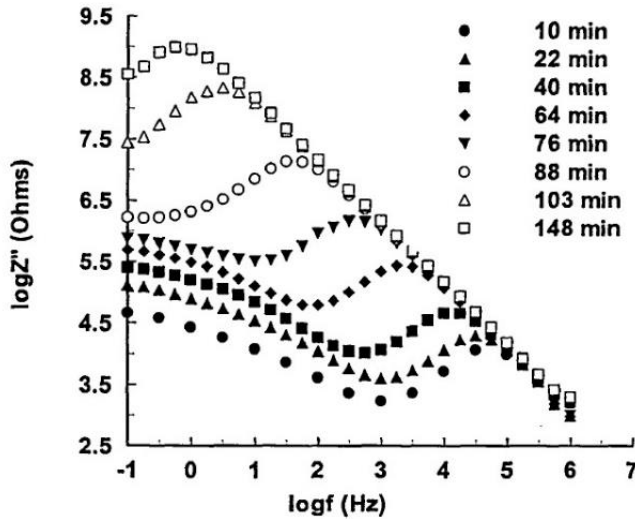

Figure 2.16: Plot of  $\log Z''$  as a function of frequency during isothermal cure of RTM6 resin at 140 °C, reproduced from [101].

#### 2.4.4.1 Comparison to DSC results for isothermal cure

For isothermal cure, the peak of  $Z''$ - referred to as the Imaginary Impedance Maximum (IIM) can be simply correlated with degree of cure as measured by DSC. [101]

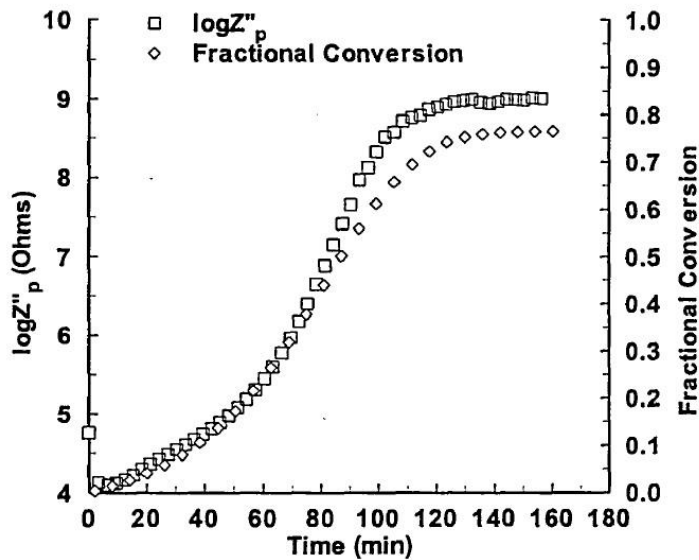

Figure 2.17: Plot of  $\log Z''$  peak value against cure time, isothermal cure of RTM6 at 140 °C, compared to degree of cure (fractional conversion) measured by DSC. Reproduced from [101].

Figure 2.17 shows a comparison between the *Imaginary Impedance Maximum (IIM)*, aka  $Z''$  peak, and degree of cure (fractional conversion) measured by DSC. The similarity in the trend can be seen. Karkanis [101] then plots both degree of cure and IIM as relative changes, between the minimum and maximum for a given cure cycle, finding close agreement as shown in Figure 2.18.

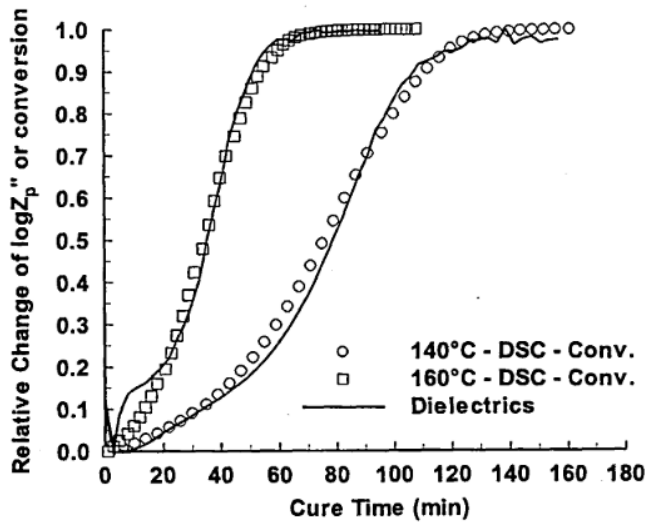

Figure 2.18: Evolution of  $\log Z''$  peak and degree of cure (conversion) scaled relative to the minimum and maximum for isothermal cure of RTM6. Reproduced from [101]

Martin et al [20] use dielectric spectroscopy to study a fast curing resin. They normalise the  $\log IIM$  for comparison to degree of cure from DSC as follows:

$$\text{Norm}(\log IIM) = \frac{\log IIM - \log IIM_{start}}{\log IIM_{end} - \log IIM_{start}} \quad (2.37)$$

For the fast curing resin, the difference between degree of cure from DSC and the normalised IIM was, according to the authors “*more significant than is usually observed in aerospace grade epoxies*”. They attribute this to difficulties with temperature when performing very fast DSC experiments. The requirement to cycle through many frequencies for each measurement means that measurement is not instantaneous, which may affect the position of the  $Z''$  maximum. Aerospace grade epoxies tend to have a cure time specified in hours[39] rather than seconds, so do not encounter this problem.

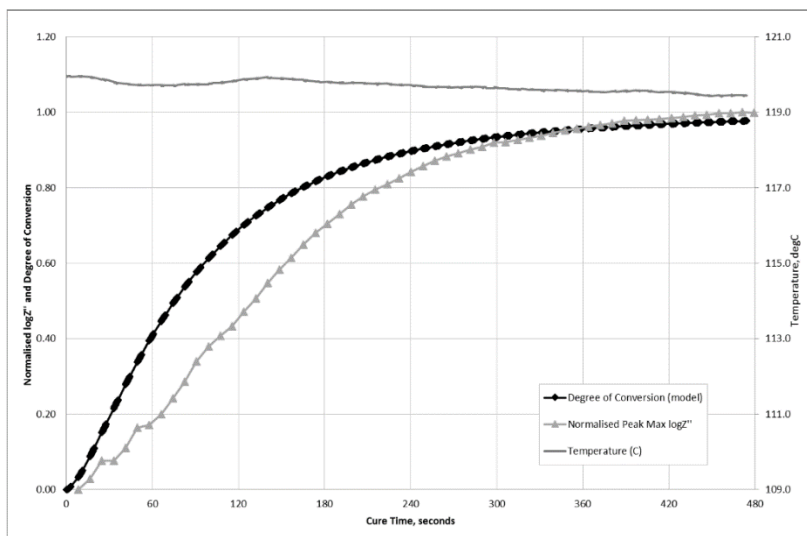

Figure 2.19: Normalised  $\log IIM$  (grey) and degree of cure (black) vs cure time. Reproduced from [20]

2.4.4.2 Determining degree of cure from IIM for dynamic cure

Isothermal cures are rarely used in industry. Dynamic (temperature changing) cures were studied by Skordos and Partridge [105], who found that both degree of cure and temperature affect the IIM.

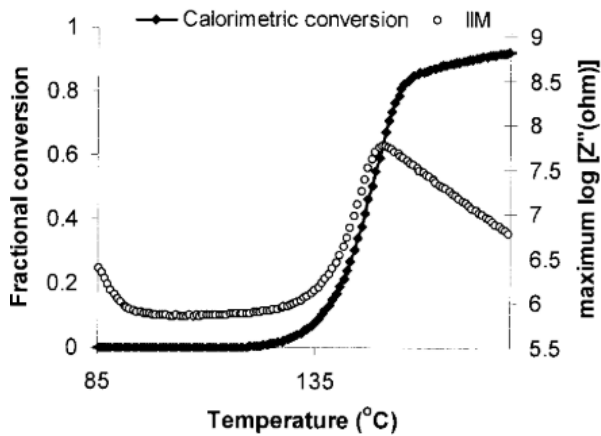

Figure 2.20: log IIM and degree of cure (fractional conversion) for dynamic cure of RTM6 at 0.25°C/min. Reproduced from [105].

In Figure 2.20, at low temperature the chemical reaction rate is negligible. Viscosity- and hence conduction is temperature dependent- so the IIM drops as the temperature increases. At intermediate temperatures the IIM closely matches degree of cure, so cure dominates the response. Finally, at higher temperatures the IIM amplitude decreases (it also moves to higher frequency) once again, suggesting that temperature is the dominating factor in this region. [105]

The temperature dependence means log IIM cannot be simply related to degree of cure for dynamic cure cycles. Skordos and Partridge[105] suggest that the derivative of log IIM with respect to cure time ( $dIIM/dt$ ) be analysed in an analogous fashion to the heat flow measurements used in DSC.

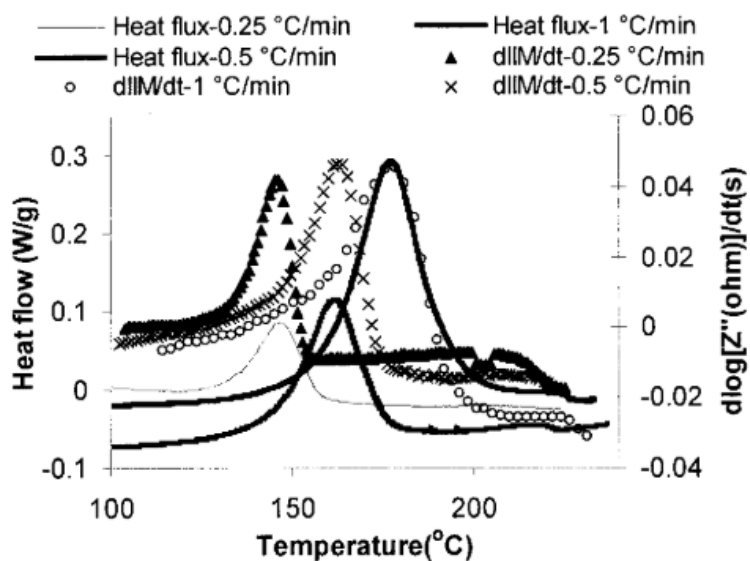

Figure 2.21: Comparison of DSC heat flux curves with derivative of IIM. Reproduced from [105].



Figure 2.21 shows that, while the amplitudes are not the same, the positions on the temperature axis of the peaks, plateaus and inflexion points from heat flux and IIM derivative are very similar for each cure (three different heating rates), meaning they occur at the same cure times.

Skordos and Partridge use this to define an 'IIM conversion' measurement (degree of cure estimated by imaginary impedance maximum), analogous to degree of cure measured by DSC, expressed as the fraction of the integral of the IIM derivative curve between the uncured and fully cured states. A comparison of this IIM conversion and calorimetric (DSC) conversion is shown in Figure 2.22.

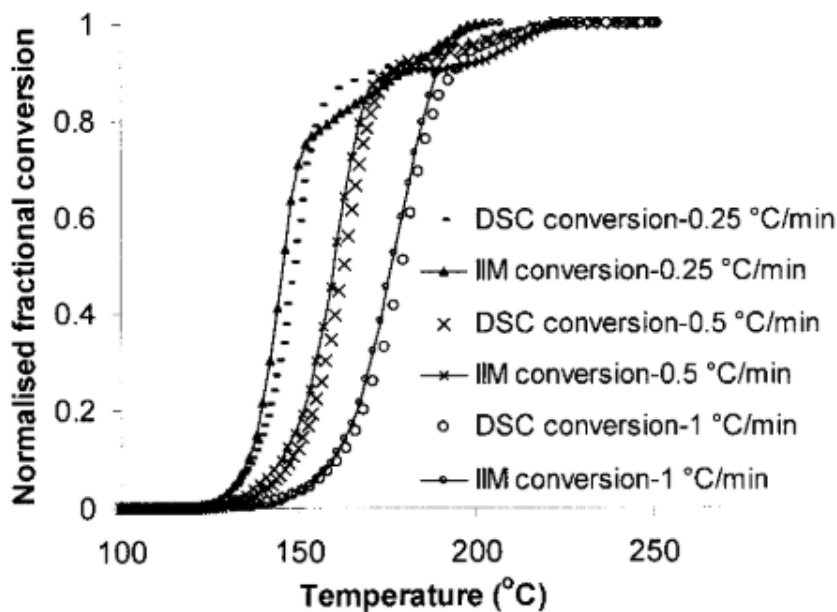

Figure 2.22: Comparison of DSC and IIM measurements for dynamic cures of RTM6. Reproduced from [105].

The results show a slight difference between DSC and IIM measures of degree of cure. Skordos and Partridge [105] suggest that, if DSC values are considered- unrealistically- absolutely correct, IIM values, based on this data, measure the conversion with an error of about 9%.

A member of the same group, Kazilas [94], uses a slightly different approach in their 2003 thesis. Assuming that the imaginary impedance maximum is a function of degree of cure,  $\alpha$ , and temperature,  $T$  of the form below, the time derivative has two parts:

$$\log IIM = f(\alpha, T) = (k_1 + k_2 T)\alpha + k_3 \quad (2.38)$$

$$\frac{d \log IIM}{dt} = (k_1 + k_2 T) \frac{d\alpha}{dt} + k_2 \alpha \frac{dT}{dt} \quad (2.39)$$

The constants  $k_1$  and  $k_2$  for a certain resin and experimental setup can be estimated from isothermal cure experiments. Kazilas and Partridge [113] use linear regression for this following isothermal cure at a range of temperatures.

Applied to a dynamic cure, the measured derivative of IIM can then be split into the two components shown in equation 2.39. Kazilas [94] finds good agreement between the first term and the reaction rate from DSC for a dynamic, constant heat rate cure, shown in Figure 2.23

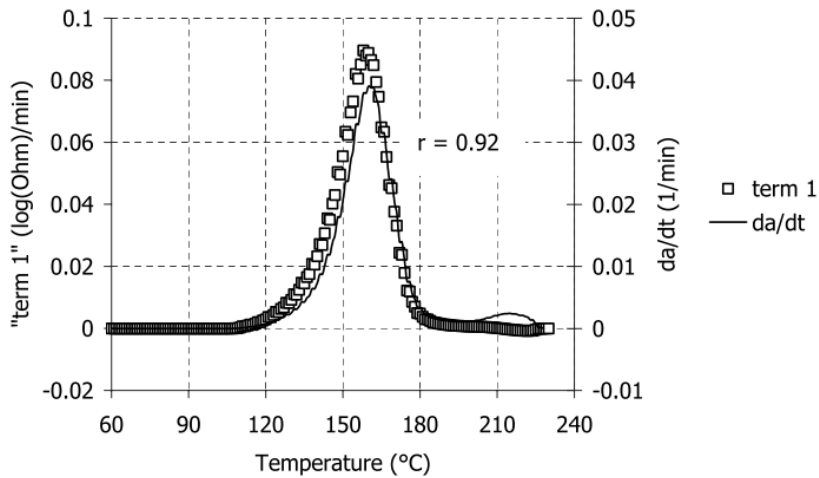

Figure 2.23: DSC and IIM derived rates of reaction for cure of RTM6 at 0.6°C/min. Reproduced from [94].

Kazilas' method tracks the main peak very closely, but not the small second peak (devitrification) at higher temperature. The 0.5°C/min trace in Figure 2.21 suggests that Skordos and Partridge's method does track this.

Jakobsen et al [89] assert that calculating the derivative of IIM becomes less reliable near the end of the cure due to noise. They test a simplified model where the IIM is a sum of a kinetic part depending only on time, and a thermal part assumed to be a linear function of temperature. Data points from the low temperature segment, before cure starts to contribute to the signal, are used to determine the coefficients  $p_1$  and  $p_2$  of  $IIM_{thermal}$ . From this the kinetic part,  $IIM_{kinetic}$ , can be studied separately and used to define an IIM chemical conversion,  $c_{IIM}$ , normalised over the time range.

$$\log IIM = \log IIM_{kinetic} + \log IIM_{thermal} = \log IIM_{kinetic} + p_1 T + p_2 \quad (2.40)$$

$$c_{IIM} = c_{max}(T) \frac{\log IIM_{kinetic}^t - \log IIM_{kinetic}^{t=0}}{\log IIM_{kinetic}^{t=\infty} - \log IIM_{kinetic}^{t=0}} \quad (2.41)$$

Here  $c_{max}(T)$  is the maximum chemical conversion that can be obtained by curing at temperature  $T$ , which Jakobsen et al determined from an empirical model for their resin. A comparison of the  $c_{IIM}$  degree of conversion and a model based on DSC measurements, shown in Figure 2.24, suggests that this approach does not model the latter part of the cure well.

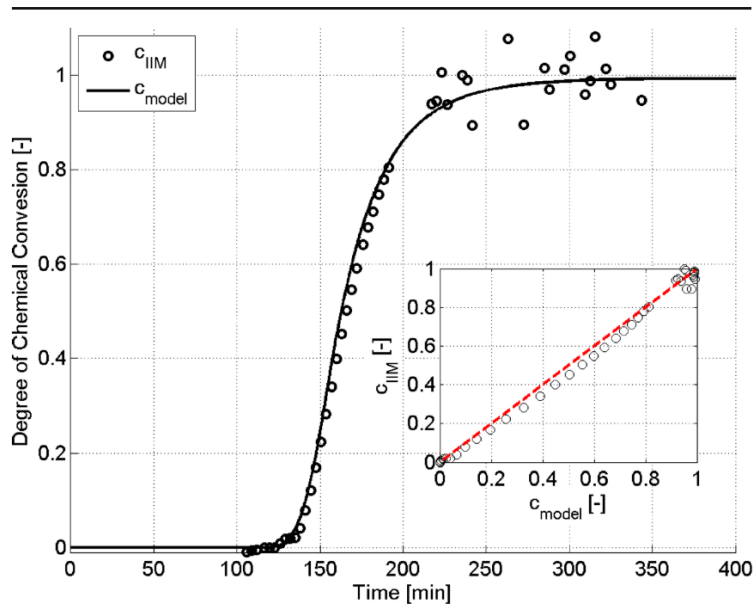

Figure 2.24: Comparison of DSC and simplified IIM derived degree of cure. Reproduced from [89]

The approaches summarised here demonstrate the principle of tracking degree of cure using the imaginary impedance maximum. A cure kinetics model can then be used to estimate the glass transition temperature based on the degree of cure. It is known from the manufacturer of the dielectric monitoring equipment (Dr George Maistros, pers. comm., 18 November 2017) used in chapter 5 that the NCAMP model is used for the 8552 resin[44], though the calculations used in the software to translate measured IIM to degree of cure,  $T_g$  and viscosity are proprietary.

#### 2.4.5 Technology transfer- can Dielectric Cure Monitoring be useful in Industry?

Dielectric cure monitoring is rare in an industrial setting, though integrated systems are commercially available and can be combined with existing manufacturing equipment, as demonstrated in Chapter 5. For the case of manufacturing of composite parts, a cure monitoring technology is useful if it delivers increased efficiencies.

In a study of opportunities for sustainable manufacturing- not specific to composites- Despeisse et al [114] found that material waste is more often minimised at the input to manufacturing, through efficiency improvements, than at the end of the manufacturing process. Similarly, preventative measures to minimise energy usage were preferred. Technological solutions were relatively unpopular for waste reduction, but maintenance and investing in efficient technologies were highly rated for energy efficiency. This suggests that energy efficiency, as in Chapter 5, should be a focus of the knowledge transfer resource for dielectric cure monitoring. This resource, following a structure- though not interface- based on the work of Fabris and Poursartip [115], is discussed in Chapter 6.

#### 2.4.5.1 Waste reduction

##### *Increasing usable lifetime of prepreg*

Kim et al [25] used dielectric monitoring to measure the conductivity of prepreg at out-times in excess of those recommended by the manufacturer. They found that conductivity (peak and at initial test temperature) and gel time during the cure both decrease as out-time increases. Using the dielectric sensors to track these materials during cure, they found that the cure cycles could be adjusted to account for the change in prepreg properties, which may increase the usable lifespan of prepreg. A conductivity measurement on a sample prior to laying up the part can therefore indicate whether or not the material is usable and if so which cure cycle to use.

##### *Active control of resin transfer moulding to eliminate dry spots*

Racetracking in resin transfer moulding can result in dry patches. Devillard et al [24] monitored the flow of resin into a test mould and used this to trigger a response to the flow pattern by opening or closing vents. They used this to eliminate dry spots for their test part.

Dielectric monitoring has been used to track the cure in resin transfer moulding in industrial settings. Breede et al [116] used dielectric monitoring to track the flow front and measure resin viscosity (based on ion viscosity) in a trial intended to represent the manufacturing process for a wind turbine main spar, used to inform a theoretical model.

Chiesura et al [117] used two different dielectric monitoring systems to track the cure of a composite version of the hinge arm for the droop nose mechanism on the Airbus A380 wing leading edge. However, the model they use is applicable only to isothermal cure, but they use a dynamic cure cycle. The dielectric loss curve correlates with temperature at least at the start, where a noticeable spike is seen. The authors plot 'degree of cure' from the start, resulting in an apparent increase then decrease in degree of cure, which the authors suggest is due to dipolar relaxation- without justification- but seems more likely to be due to temperature changes.

#### 2.4.5.2 Cure Optimisation

A study of cure cycle optimisation to minimise energy use is presented in Chapter 5, using a stepped wedge test part as many production parts vary in thickness. Here only the temperature aspect of the cure- hold temperatures and durations- is varied. Maistros and Partridge [84] used a similar test part to determine the optimum time to apply pressure during a cure.

Kobayashi et al [76] have developed a grid of parallel-plate based dielectric sensors and used these to track through thickness degree of cure across the area of a part. This has been applied to a component from a human powered aircraft.

## 2.5 Comparison to other cure monitoring techniques

### 2.5.1 Direct Current (DC) resistance analysis

Direct current systems use similar sensors to those used for dielectric analysis. The sensor at its simplest consists of two electrodes which are placed in a region where they will come into contact with the resin. When there is resin between the sensors, it completes the circuit. As the resin cures, the resistance in the circuit changes.

DC sensing may be a cheaper alternative to DEA, but by its nature provides less detail on the cure process due to the lack of a frequency domain [46], and is as yet unproven for quantitatively tracking degree of cure. The papers Konstantopoulos et al's review[46] referenced in the DC analysis section show work on flow sensing[118], viscosity monitoring[119] and identification of  $T_g$  from a curve feature[120] with DC resistance sensors, but do not report on tracking degree of cure.

Correlation between resistance and viscosity was demonstrated as early as 1982 by Tajima [107]. Pantelelis et al [121] claim that the resistance measured tracks first viscosity, then after gelation tracks degree of cure or  $T_g$ . Correlation between expected  $T_g$ , from the resin manufacturer's datasheet, and resistance for an epoxy system is shown, but there is no independent direct measurement of  $T_g$ . The same is true of Pantelelis and Millar's 2011 conference paper [122] which shows correlation between resistance,  $T_g$  and degree of cure, but the latter two are based on calculation only rather than independent laboratory tests.

Hsiao [120] tracked the electrical resistance in a single carbon fibre during resin cure. After correcting for the change in resistance due to temperature Hsiao finds a possible correlation between features of the resistance versus temperature plots from the cooling stage- i.e. at or near completion of the cure- and measurements of  $T_g$  by DMA, with features approximately matching both the storage modulus knee and tan delta peak. This cannot however be used for tracking  $T_g$  throughout the cure process. This temperature correction process could, if it can easily be carried out, make it easier to identify end of cure during a non-isothermal cure cycle from DC resistance. The change in resistance due to temperature otherwise makes this difficult, as shown in Chapter 6.

Meier et al [80] compare DC, DEA and ultrasound sensors. They showed a correlation between the measurements during cure for all three but did not attempt any quantitative link to material properties such as degree of cure. The same study found that where a thermoplastic layer is placed between the sensors and the part, the DC sensors detected only the thermoplastic, whereas the electric field of the DEA sensors had sufficient penetration to measure the flow front and cure of the thermoset through this thermoplastic layer.

### 2.5.2 Thermocouples

Thermocouples are widely used in industry [45] for monitoring and process control, and built into most autoclaves [123]. Monitoring the material temperature and that of the surrounding environment allows easy identification of heat output from the exothermic reactions during the (exotherms)[49]. These measurements provide a traceable proof of the part's thermal history.

Measurements of temperature only may be used to estimate degree of cure in conjunction with a theoretical model[124], however models may differ from reality, as can be seen in Chapter 5.

Measurements of temperature alone do not give an indication of the status of the chemical reaction. Using models, even well validated ones, relies on a theoretical representation of the resin, which cannot allow for variation between batches as it does not track the resin properties themselves.

Thermocouples are however robust, simple to use and well known in industry. Where tracking the thermal history of the part is all that is required- if the actual cure state is not important- they serve the purpose but for monitoring the cure itself are considered to be of limited use [125].

Thermocouples are used in conjunction with other cure monitoring methods, such as DEA. Use of temperature measurement alongside cure monitoring sensors- whether separate or built in- is needed to account for changes in the sensor output due to temperature rather than due to cure[45].

### 2.5.3 Infrared Spectroscopy

Fernando's 2005 overview of fibre optic sensing for use with composite parts [126] lists infrared and Raman spectroscopy as suitable for monitoring chemical concentration. As the cure is a chemical reaction, these methods can be used for tracking the progress of the cure. Measurement of the chemical species present is the most direct method for measuring degree of cure, using the areas of the spectral peaks (normalised) to follow the conversion [127].

Spectra can be obtained either by transmission of light through a cleaved optical fibre embedded in the part, or through evanescent wave spectra. Evanescent wave spectra have also been measured through E-glass fibres[127], [128].

Comparisons to DEA are more frequently made with laboratory systems rather than optical fibres. Lab based Raman spectroscopy has been compared to parallel plate based dielectric analysis and DSC measurements for monitoring of epoxy cure, by Hardis et al [38], for isothermal cure. A single frequency was used for DEA measurements, choice of which was not justified in the paper. Degree of cure from Raman spectroscopy was calculated based on the intensity of a peak attributed to the epoxide group divided by a reference peak that should not change, as follows:

$$\alpha(t) = 1 - \frac{\frac{I_{1255}(t)}{I_{ref}(t)}}{\frac{I_{1255}(0)}{I_{ref}(0)}} \quad (2.42)$$

Reasonable agreement was found between DEA, Raman spectroscopy and DSC.

Mijović et al [67] compared degree of cure measured by DEA to that measured by Fourier-transform Infrared (FTIR) spectroscopy, by comparison of the initial and test time areas under the peaks corresponding to epoxy absorption, which decreases as the cure proceeds, and a reference peak which remains constant. The two methods showed good correlation for isothermal cure as shown in Figure 2.25

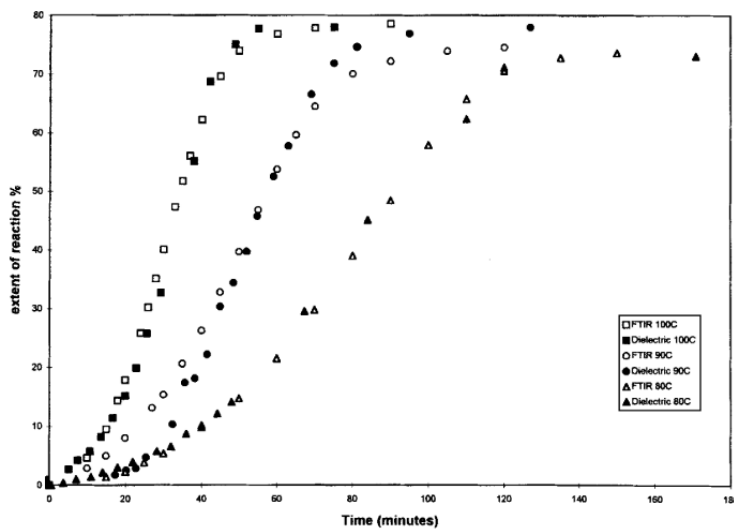

Figure 2.25: Degree of cure vs time as measured by DEA and FTIR spectroscopy. Reproduced from [67].

Kortaberria et al [51] carried out a similar experiment, using an epoxy resin with a modifier, but while the cure is discussed and compared to the IR spectroscopy results using the components of complex permittivity they do not attempt to estimate degree of cure from the permittivity.

#### 2.5.4 Ultrasonic Cure Monitoring

Ultrasonic waves are transmitted through the part as it cures, either from a transmitter on one side of the part to a receiver on the other (compression waves) or with a transmitter and receiver at the same point, where the waves are reflected off the far edge of the part (shear waves) [46].

Reflections may also be caused by defects and discontinuities within the part. For this reason, ultrasound is also used in non-destructive inspection of cured parts.

Ultrasonic sensors can in theory be used to monitor cure through the thickness of a part. Where time of flight is used to calculate the velocity of the sound wave the spacing must also be kept constant, but the reflected peak amplitude can also be used.

Chilles et al [129] have developed an inductively coupled ultrasonic sensor. These sensors are intended to be used during the lifetime of the part for structural health monitoring as well as for monitoring the cure, which was tested in their later paper [86]. During the cure, the transmission and receiver coils are placed outside the vacuum bag. Two types of ultrasonic sensor were tested- in different materials, and both the velocity of sound and normalised peak amplitude of the return signal were measured. In both cases, the signal was not identifiable when resin viscosity was relatively low. Comparison to DEA measurements suggests the ultrasonic sensors were only able to monitor cure after or near gelation in this instance [86].

As a reflection system, this measures shear waves, which were also only able to be detected through part of the cure in Challis et al's work [130], [131], appearing once gelation had at least started. The DEA sensors were used to monitor  $\log(IIM)$ , though the cures were not isothermal. Approximate correlation was seen between the IIM, DSC results and ultrasonic results.

By comparison, compression waves are shown by both Challis et al [130], [131] and Shepard et al [132] to be detectable throughout the cure. However, requiring transmitter and receiver at either side of the part makes these less practical for structural health monitoring- though feasible for cure monitoring if embedded in the tool, as proposed by Liebers et al [133].

## 2.6 Microfocus X-Ray Computed Tomography for Defect Tracking

Microfocus X-Ray Computed Tomography, hereafter referred to as XCT, is not used to track degree of cure. However, this thesis presents a method for using XCT to track the geometrical evolution of defects or features throughout the cure process.

### 2.6.1 XCT of Composites for Defect Evaluation

XCT uses many X-ray images of the object under test to form a 3D representation, through reconstruction algorithms.[134] Industrial CT scanners commonly use a cone beam of X-rays, with the object sitting between the source and detector on a stage which slowly rotates.

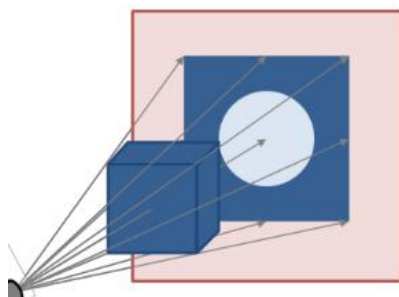

Figure 2.26: Cone beam XCT with a flat panel detector. Reproduced from [134]



The magnification available is limited by the geometry of the CT scanner, detector pixel density, X-ray focal spot size and sample size. Within the other limits, smaller samples allow for greater magnification. The available magnification varies considerably between different CT scanners.

Rueckel et al [135] have evaluated the dependence of spatial resolution on X-ray tube parameters for a particular CT scanner, demonstrating that at large magnifications the focal spot size- which becomes larger at higher tube power- becomes the limiting factor, meaning there is no gain in attempting to achieve better resolution by geometric magnification beyond this point.

Synchrotron XCT is also used in composites research. Garcea et al's 2018 review of XCT of composites [136] discusses the relative merits of synchrotron and industrial XCT. Synchrotron X-ray beams are usually monochromatic and higher flux than industrial CT scanners. This gives a high signal to noise ratio and allows use of phase contrast, so fibres and resin can be easily distinguished. Synchrotron beamlines are also able to achieve greater magnification than the majority of industrial CT scanners, though nano-CT scanners which use lens systems to achieve sub-micron resolution are available [137]. The high flux in particular makes synchrotrons suitable for time resolved XCT, as this allows faster imaging. However, access to synchrotrons can be competitive, so these are not practical for common use in an industrial environment. Cole et al [138] have used a laser wakefield accelerator for XCT imaging. This group have discussed (Dr Daniel Symes, pers. comm., 13 July 2017) the possibility of achieving high flux time resolved XCT with a high repetition rate laser, though the prospect of buying an industry ready system in the same manner as an XCT scanner is some way off.

#### 2.6.1.1 Measuring voids with XCT

##### Surface Determination

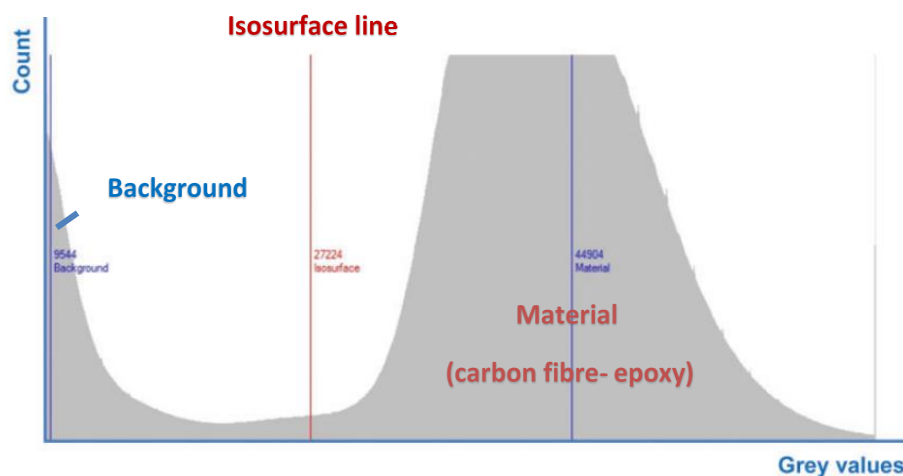

Figure 2.27: Surface determination for scan of a carbon fibre-epoxy sample. Reproduced from [139].

Annotations added.

The boundary between the test material and air must be defined, determining the surfaces (internal and external) of the test object. The grey values of the pixels in the image are used for this, where either automatic algorithms or manual selection is used to place an 'isosurface' at a grey value between the peaks seen for the background and the material, such as in Figure 2.27.

The simplest method, ISO-50%, uses a threshold value based on all the voxels in the volume. [140]

Borges di Oliveira et al [140] have conducted an investigation into different methods for surface determination in multi-material objects, finding that the presence of a higher absorption material affects the surface found for the lower absorption material but not vice-versa. This should be borne in mind where glass fibre reinforcements are used.

They also found that for the ISO-50% method error on the surface determination could be up to 1 voxel in size. This method cannot be applied automatically in a multi-material sample. Carbon fibres in an epoxy-based resin are however commonly detected as only one material, being mostly carbon, for example as shown by Stamopoulos et al [139].

#### *Measuring Voids*

Voids can be measured from reconstructed 3D volumes using commercial software such as VG Studio Max [141]. The determined surface can be used to measure voids within the whole sample, or a defined region of interest [141]. Kastner et al demonstrated the effect of different thresholds for the defined surface on the measured porosity of a sample. [142]

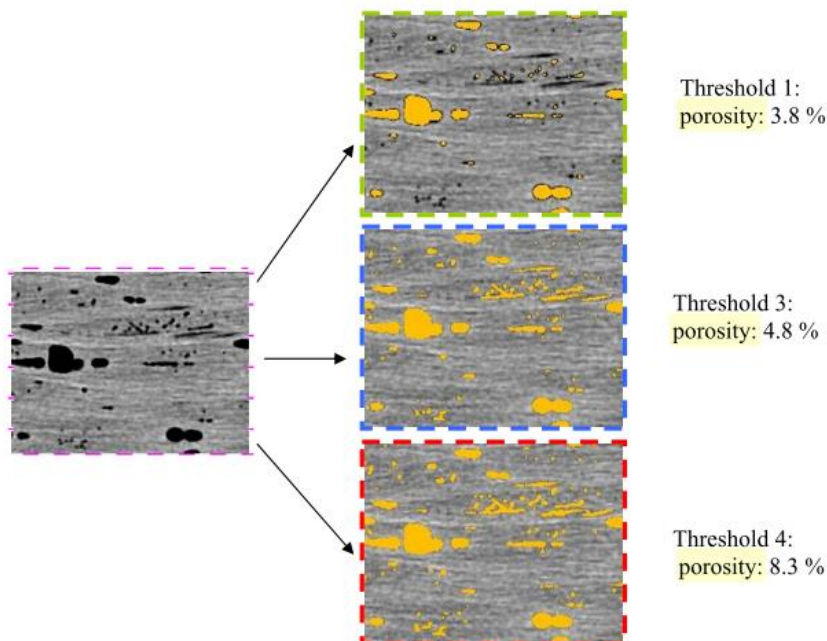

Figure 2.28: Influence of threshold on porosity. The left picture is a slice from a CT volume. The three pictures on the right show the voids measured at different thresholds. Reproduced from [142]

Kastner et al's 'threshold 1' is an ISO-50% method. Other methods are superior for measuring total porosity, as shown in Figure 2.28, however VG Studio Max also offers an option to record only voids of a user defined size range. If the required size range does not include the smallest voids- advisable in a noisy scan where these may be false readings- or the resolution is low enough that these are not seen- the automatic ISO-50% method may be sufficient.

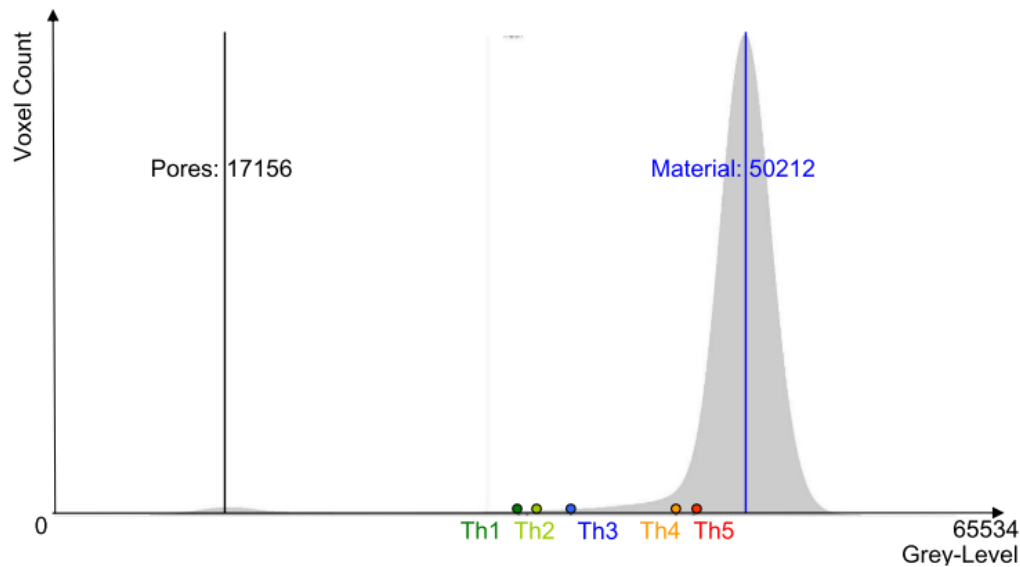

Figure 2.29: Thresholds (Th1-5) on grey value histogram for a composite part. Reproduced from [142]

This paper also demonstrated that some surface determination methods show variation with sample resolution, while others do not. Sadly the 'threshold 1' method relevant to VG Studio Max is not included in this analysis, though the similar 'threshold 2' showed little variation with voxel size.

## 2.6.2 XCT Studies of Changing Objects

### 2.6.2.1 Multiple Samples

The simplest method is preparation of a variety of near-identical samples, with each having been processed or tested to a different point. These can be compared in a general sense, but specific features cannot be tracked as each sample is different. There will inevitably be variation between the samples. It is also possible that quenching or relaxation of samples may affect the result.

This approach is taken by Centea and Hubert [27] in their study of impregnation of an out of autoclave prepreg. They prepared numerous laminates and partially cured each to a different point in the cure cycle, quenching each sample by immediate transfer to a freezer. They used a high resolution Micro-CT scanner to image each sample. Void content was measured for each sample using averages of small sections in each to allow for variation in the samples. This study did not include deliberate defects in the samples.

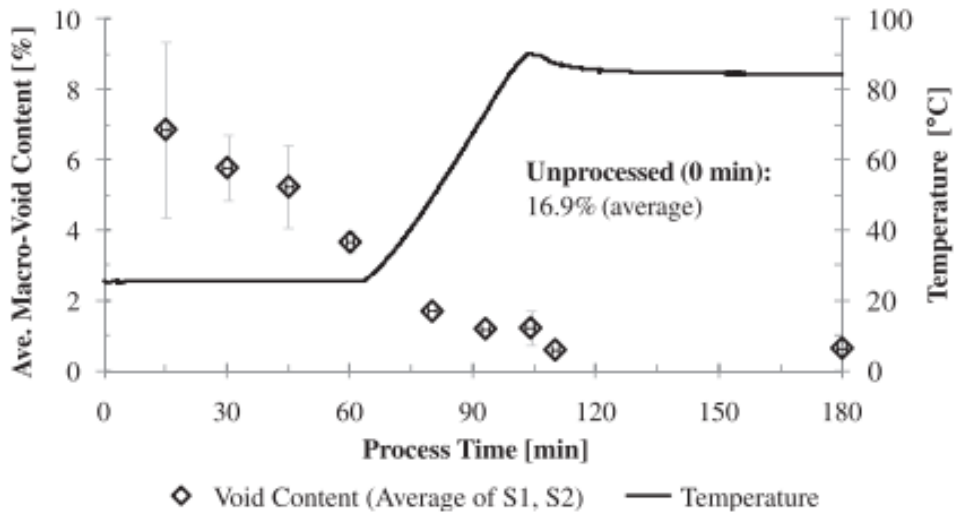

Figure 2.30: Porosity during prepreg impregnation, multiple samples. Reproduced from [27]

Centea and Hubert [27] found that this average void content decreased through an initial debulk/room temperature hold and the start of the ramp before appearing to stabilise just into the higher temperature hold, though there are measurements only near the start and end of this hold.

Serrano's 2018 thesis [28] extends this work, studying debulk and cure of two out of autoclave resins. Again, multiple samples are used. Serrano compares the measured porosities of the samples at chosen points in the cure cycle to the viscosity of the resin (Figure 2.31), then uses the results to suggest an optimised cure cycle for lower final porosity (Figure 2.32).

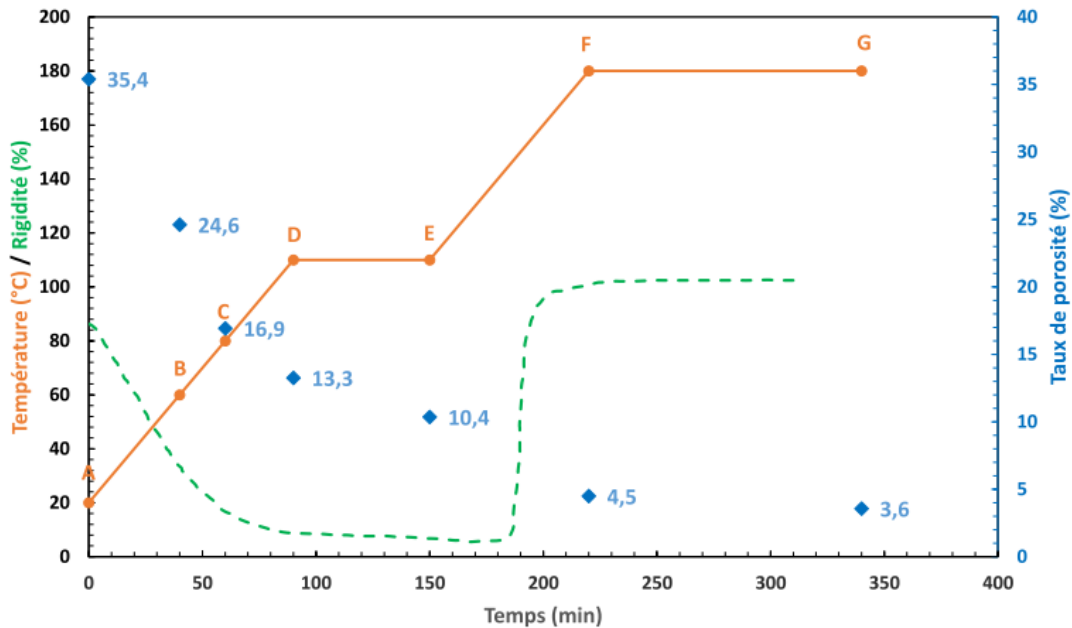

Figure 2.31: Porosity, viscosity and temperature over time, recommended cure cycle. Reproduced from [28]

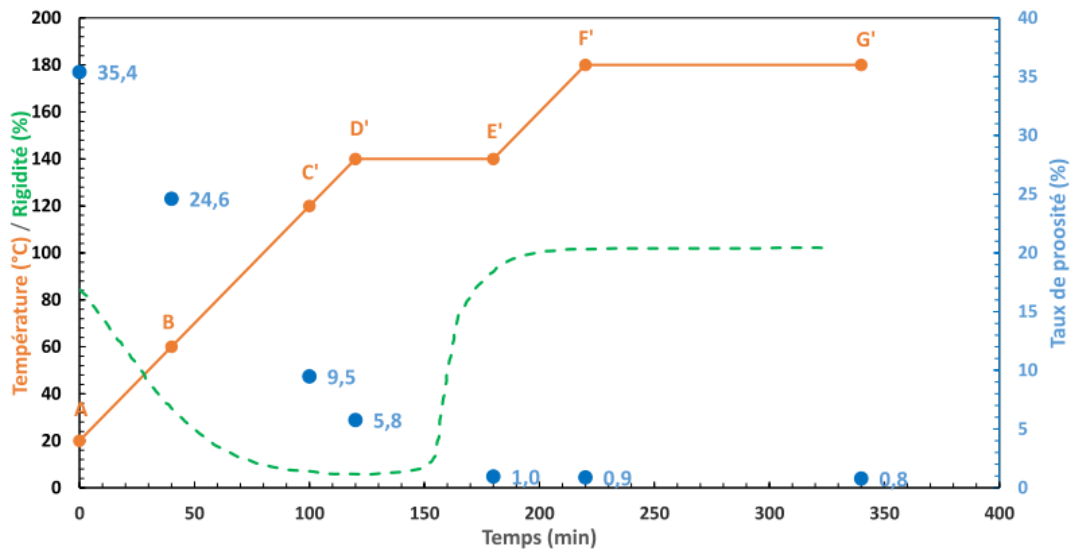

Figure 2.32: Porosity, viscosity and temperature over time, optimised cure cycle. Reproduced from [28]

#### 2.6.2.2 4D XCT: Time resolved imaging

Repeated XCT Scanning of a sample which changes can be either *Ex-Situ*: where a sample is scanned, removed from the CT scanner, subjected to a change (such as application of heat or a force), then returned to the CT scanner and scanned again; or *In-Situ*: where the change is applied inside the CT scanner or synchrotron beamline using an experimental rig.

*In-Situ* experiments can be further subdivided into interrupted in-situ, where the application of heat or force is removed while the scan takes place, allowing the material to relax, and uninterrupted in-situ, where scans are taken either at intervals or continuously during the application of heat or force. Garcea et al [136] illustrated these options as shown in Figure 2.33.

As faster scans can be achieved on a synchrotron beamline than in an industrial CT scanner, synchrotron XCT is often preferred for in-situ scanning. However, industrial CT scanners have been successfully used for in-situ experiments and are also used for ex-situ.

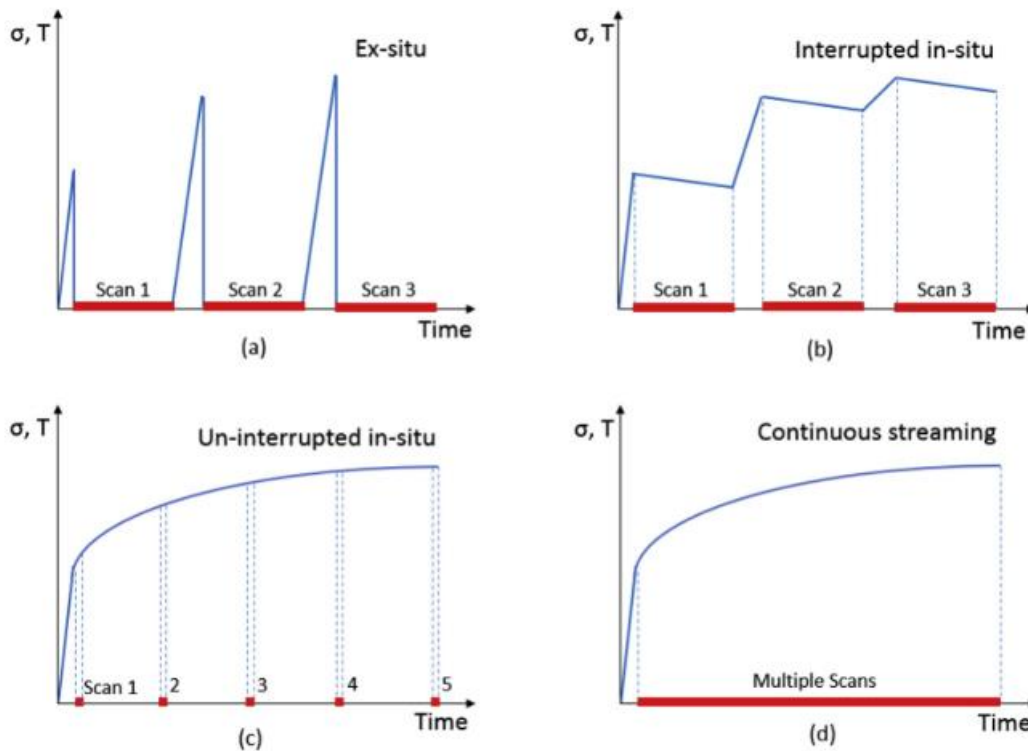

Figure 2.33: Strategies for time resolved XCT of a changing single sample. Reproduced from [136].

#### *Ex-Situ*

Industrial XCT has been used for a variety of ex-situ experiments. Bull et al's [143] study of compression after impact failure, for example, used ultrasonic C-scans to measure the damage area after impact, indicating where to place samples in the CT scanner to image the damage area. After an initial scan of coupons, they were then re-scanned following incremental applications of load, until each had failed. This manner of re-scanning after incremental changes is typical of an ex-situ experiment.

#### *Interrupted in-situ*

An example of interrupted in-situ testing of composites, Garcea et al [144] used synchrotron XCT to study fatigue. Each sample was subject to an initial 700 cycles, then placed in an in-situ load frame in the synchrotron beamline. A load just under the maximum used was applied to open the crack, and the sample was scanned. Following 100 cycles in-situ, the sample was scanned again.

Vilà et al [145] used a synchrotron to study vacuum infusion of a single glass fibre tow, using a resin analogue. The tow was impregnated in steps, with a high resolution (single fibres clearly visible) scan after each step, allowing the flow front to be tracked. Voids were caused by minor air leaks at the inlet, which could be tracked passing through the tow, perturbing the fibres and leaving a trail of smaller voids behind where the fibres had been moved.

### *Uninterrupted in-situ*

Scott et al [146], carried out uninterrupted in-situ tensile tests of carbon/epoxy cross-ply laminates using synchrotron XCT imaging. Test coupons were placed in a load frame in the synchrotron beamline and scanned. The load was increased incrementally and the test coupon scanned under load at each step. Loading and scanning continued until failure. Reconstructions were used to identify fibre breaks, splits, delaminations and ply cracks as the coupon progressed towards failure.

Thompson et al [147] used a synchrotron to track an out of autoclave prepreg during debulking, with images taken before debulk and at 1, 6 and 12 hours. Void evolution was tracked during debulking.

Ferré Sentis et al [148] used a combination of continuous and uninterrupted *synchrotron* scans in their study of compressibility and pore transport in sheet moulding compounds (SMC). Cylinders of SMC were subjected to compression using a micro-rheometer in the beamline. Extremely fast, 2s scans were used. For high strain rate experiments, the loading was paused for each scan, whereas for low strain rate experiments, where the compression occurred more slowly continuous scans were performed. Pores were identified using a simple threshold in the grey values as above, and the results show a decrease in both overall porosity and mean pore size as strain is increased.

A good example, albeit in a different field, of how an *industrial CT scanner* can be used in this manner is Keyes et al's [149] mapping of soil deformation around the root of a growing plant.

This used 7 minute scans in a Nikon HMX 225 ST micro-focus XCT scanner. Binning was used on the detector, combining a 2x2 patch of elements into a larger virtual element. The lowest energy which resulted in a usable image was employed, to minimise noise. The plant sat in a soil filled tube of diameter 30mm and was scanned repeatedly over 20 hours as it grew. Digital volume correlation was then used to track the soil displacement caused by the growing root.

More relevant to this work is Plank et al's [150] in-situ observations of bubble transport in neat resin during cure. A Nanatom 180NF XCT nano-focus XCT scanner was used, with 4x4 detector pixel binning. 48 scans were made over 300 minutes, during which the resin was heated in a small test chamber. A 5x5 median filter was used on the resulting volumes to remove noise, and voids were measured. Movement of air voids was tracked; voids were seen to rise and combine together. A water bubble was injected into the resin partway through the cure, which was seen to increase in volume as the temperature rose, consistent with theoretical predictions. The progress of the water bubble is shown in Figure 2.34.

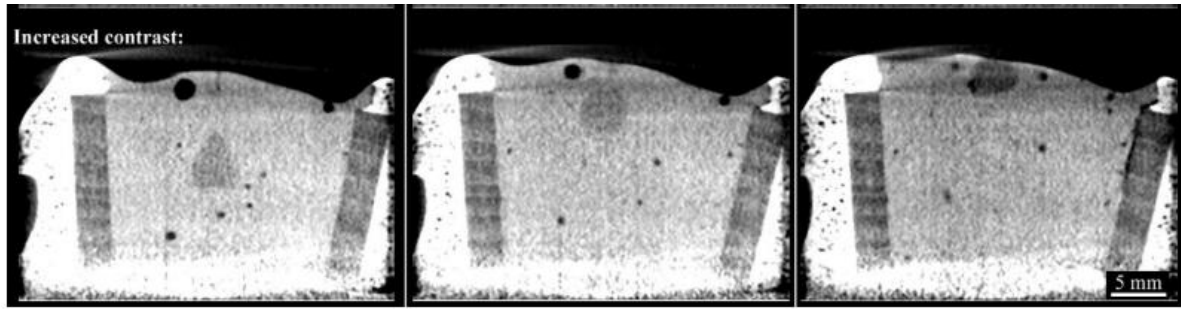

Figure 2.34: XCT slices showing a water bubble (diameter  $\sim 4.2\text{mm}$ ) in epoxy resin (without fibre reinforcement) during cure. Reproduced from [150]

## 2.6.3 Industrial Applicability

### 2.6.3.1 Example: Tow gaps and ply drops in Automated Fibre Placement

Automated Fibre Placement (AFP) involves laying unidirectional material (usually prepreg) onto a tool using a robotic system. A prepreg tape is split into thin strips which are pressed onto the tool using a roller. The AFP head can steer around curves. Gaps and overlaps are a common issue, which can result for example from steering (Figure 2.35), tolerance in the AFP head placement, or positions of cuts in each strip at the boundaries between tape sectors (Figure 2.37). [7], [151]–[153], or may be a necessary design choice.

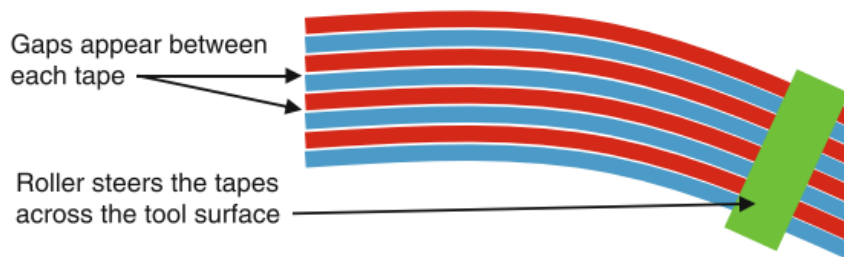

Figure 2.35: Tow steering in Automated Fibre Placement. Reproduced from [4].

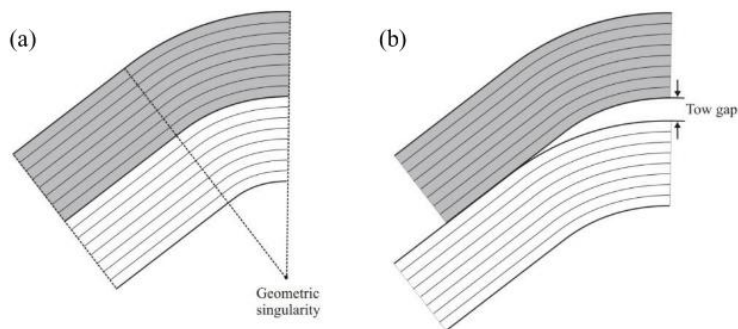

Figure 2.36: Where AFP tapes are laid up around a corner, either the radius becomes too tight, causing wrinkling (a), or a gap is necessary (b). Reproduced from [154]



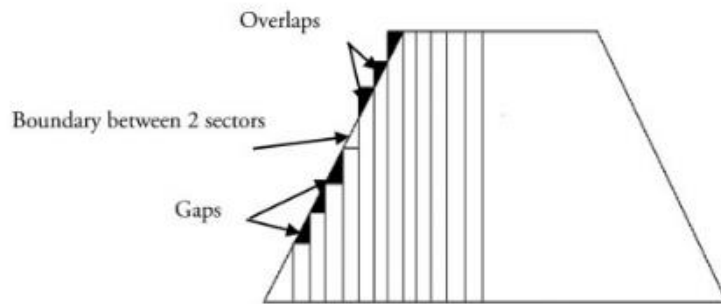

Figure 2.37: AFP tow cuts at boundaries create gaps and overlaps. Reproduced from [153].

Gaps resulting from cuts in the tape, as in Figure 2.37, are a *ply drop* type, cutting across the fibre direction. *Tow gaps* are along the fibre direction, as in Figure 2.36 or Figure 2.35.

These defects can influence the properties of the composite part. Croft et al [155] studied the effect of AFP defects, including tow gaps, on tensile, compression and in-plane shear strength, along with open hole tension and compression strength. Elsherbini and Hoa [153] used both experiment and finite element modelling to study the effect of AFP tow gaps on fatigue behaviour, finding for a given maximum applied stress that a sample with a defect would fail in fewer cycles, with the effect more significant at higher stress. Li et al [156] created finite element models for out-of-plane waviness and ply thickness variations caused by tow gaps and overlaps and used these to predict the reduction in strength caused by these defects.

The position of the defects matters. Rhead et al [154] found that where a test coupon is impacted in a region with a tow gap near the impacted surface, damage during compression after impact testing is greater than where the tow gap is closer to the opposite surface to the impact.

Lambert et al [18] used multiple sample XCT in fatigue testing of samples representative of wind turbine blades. Samples were scanned and voids measured by manually segmenting the image based on grey levels, as in the simple threshold method. Some samples were then fatigue tested to failure, and others to various proportions of their estimated life, with XCT scans taken at the end of each test. Different samples were used for each point along the estimated life span. The samples tested showed a correlation between the size of the largest void at a particular point in the layup and the number of cycles to failure- but no clear correlation between the largest overall void or total void content and number of cycles to failure.

#### *Modelling tow gaps and overlaps during cure*

Belnoue et al [151] developed a model for the evolution of tow gaps and overlaps. This describes flow and compaction, with an elastic component from fibre deformation and a viscous component from resin flow. The model is combined with a cure simulation for heat transfer and cure evolution.

This model was compared to a test part, before and after cure. Gaps are seen to reduce in size as the cure progresses, and waviness is induced in the surrounding plies. However, the model shows only the fibre position, so gap filling by resin only is not shown in the results. The 'gaps' visible in Figure 2.38's model prediction correspond with areas filled with resin in the micrograph of the part.

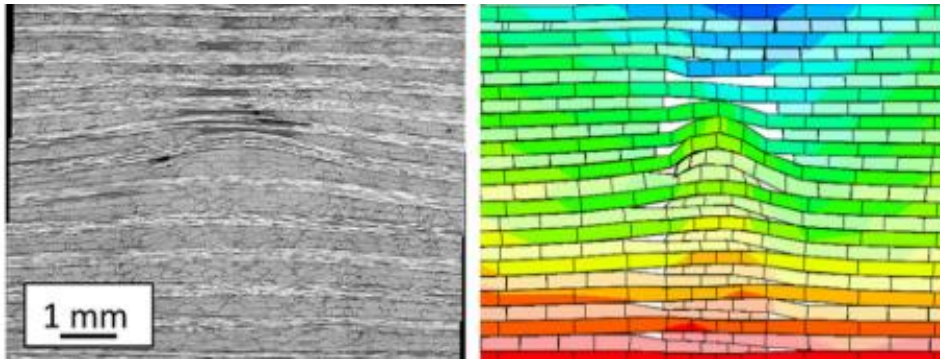

Figure 2.38: Comparison of experimental result (left) and end state of simulation. Reproduced from [151].

### 2.6.3.2 Void growth

Tow gaps and ply drops in a part enclose air, forming voids in the composite. Resin and fibres can, where possible, flow into these voids, but there are also mechanisms which lead to void growth (or formation) during cure. This is particularly relevant for vacuum bag only processing, where there may not be sufficient pressure to force gases or moisture into solution in the resin [157]. Liu et al [158] found “an exponentially decreasing relationship between the void content and cure pressure”.

Wood and Bader [159] list four sources of porosity in a cured laminate. The first, mechanical entrapment of air during lamination, occurs when a tow gap or ply drop is included in the layup. The other three occur at a smaller scale- dissolved and adsorbed water and gases in the resin, volatiles formed during cure and porosity intrinsic to the prepreg- where the resin does not completely fill all small scale gaps between the fibres.

A model for the evolution of a single small (compared to the volume of resin) spherical bubble of vapour was presented by de Parscau du Plessix et al [160] based on diffusion in an infinite medium. The model assumes the resin is an incompressible, homogeneous Newtonian fluid. While not applicable to the evolution of large voids such as those from tow gaps, a model such as this may be relevant to smaller voids remaining- or forming- later in the cure. Their model predicts an increase in void radius as resin viscosity decreases and temperature increases, before pressure is applied in their cure cycle. The final void sizes predicted by the model are found to be comparable to those measured from experimental micrographs of cured composites and larger voids are seen where the resin has been stored at higher humidity.

Grunenfelder and Nutt [161] further studied the effect of moisture content on void formation for composites cured in both autoclave and vacuum bag only setups. They again used a diffusion model for void growth, comparing it to experimental results. They found a very clear increase in void volume fraction with relative humidity for material stored at relative humidities of over 70% and cured using vacuum bag only processing. While this demonstrates the effect of moisture on void formation, materials are not often stored at such high relative humidities.

The XCT studies, using multiple samples processed for different lengths of time, of void volumes in composite parts by Centea and Hubert [27] and Serrano [28] do not show any increase in void volume following the initial decrease with consolidation. As different samples are used rather than tracking a single sample, and relatively few scans are taken, it is possible that such an effect may have been missed. Plank et al [150] observed growth of a water bubble in neat resin during cure which they consider a match to the theoretical model used by Grunenfelder and Nutt [161].

#### 2.6.3.3 Defects can be unavoidable

Potter's 2009 work [26] introduces a taxonomy of defects in composite parts. 132 defect types are presented, arising from a wide range of possible issues during the manufacturing process. In some instances these are unavoidable, particularly for parts with doubly curved surfaces where the fibre tows cannot perfectly conform to the three dimensional shape without some gaps or overlaps. Where the geometry makes gaps necessary, the position of these gaps may be a deliberate design choice [154] such as in Figure 2.36. Ply drops may also be designed into a part- for example to decrease the thickness in a certain area.

Defects such as these may also result from variation in lay-up, either from the differing methods used by human laminators or the limitations of automated fibre placement [4].

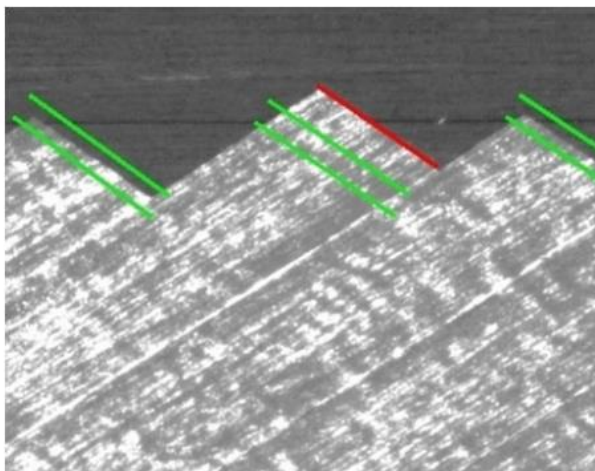

Figure 2.39: Projected green laser lines show the acceptable positional limits for tapes being laid down by an AFP machine. AFP tape is usually ~6mm wide. Reproduced from [4].

Achieving millimetre accuracy- or better- is extremely difficult in practice. An example is shown in Figure 2.39. Accidental gaps and ply drops can easily occur during layup, in addition to those required by the design. It is hoped that improved understanding of defect evolution could in future be used to ascertain the accuracy which is necessary to achieve the desired result, which may lead to improvements in manufacturing efficiency.

## 2.7 Knowledge Management

For the results of this work to be useful in industry, they must be recorded and shared in a manner which promotes their use. Chapter 3 uses techniques from knowledge management to investigate how knowledge is shared in industrial and academic organisations.

### 2.7.1 All In The Mind?

The concept of a knowledge worker was introduced by Drucker [162], [163] in discussions of the value of knowledge to the economy. *“The man or woman who applied to productive work ideas, concepts and information rather than manual skill or brawn”* [163] is considered key to the modern economy. Theories of knowledge management reflect the importance of people, considering knowledge as part of a mental model in a brain [164], [165]. Scott [166] relates this to the ‘gestalt’ psychological tradition, where the world as perceived by an individual is determined in the mind by their specific conceptual schemes- one person may literally see the world differently to another. Through reading a text, one can learn only information [165] which can be codified. Tacit knowledge may be difficult or impossible to record [167], [168], yet Ghaziri and Awad [169] write that *“the greatest factor in knowledge management is the sharing of tacit knowledge”*.

#### 2.7.1.1 Codifying knowledge

Davenport and Prusak [168] discuss knowledge repositories of three varieties: external (e.g. competitive intelligence), structured internal (reports etc.), and informal internal: such as lessons learned and know-how (i.e. practical knowledge of how to accomplish something). They recommend recording informal discussion for codifying the latter, requiring human interaction.

They recommend constructing repositories only after considering 4 principles of codification [168]:

- Deciding what business goals the codified knowledge will serve
- Identifying appropriate existing knowledge
- Evaluating knowledge for usefulness
- Identifying an appropriate medium for codification and, crucially, distribution.

'Medium' here can also include the language used, as it is important that all those accessing the information interpret it in the same way. The word 'language' itself is here an example- it could mean a set of symbols, gestures and/or sounds used by a group of humans to communicate, technical terminology or jargon specific to a profession, or computer programming code of a particular family. Add an exclamation mark, and it becomes an exhortation to refrain from swearing.

Potter [4], in studying how skilled laminators lay up composite parts, found it necessary to develop language to describe the process. Without this, their expert knowledge could not be codified. Potter laments that if manufacturers cannot tell designers how best to use their skills, designers are unlikely to consider ease of manufacture in their work.

Structuring a knowledge repository in an accessible manner and developing processes which encourage its use are important aspects of knowledge management. Ghaziri and Awad [169] complain that work in this field often focuses only on content, rather than how best to communicate the material. Software tools which assist in tagging, searching and linking knowledge between reports can encourage use of codified knowledge, such as that trialled at NCC by Joel-Edgar and Gopsill [170], facilitated through this EngD project. Barnard and Rothe [171] present a software portal intended to facilitate access to both documentation and tacit knowledge. They split the content into 'knowledge objects'- such as documents, databases and designs- and 'reference persons'- a directory of experts. Knowledge codified in this fashion can easily become out of date [169], so refreshing and adding to the knowledge repository must be considered.

While everyone should engage in knowledge management through normal work processes, Davenport and Prusak [168] recommend employing skilled persons to facilitate codification and communication, as not all experts are talented communicators. (They specifically refer to engineers, without justifying this choice). *"Knowledge management will not succeed if there are no workers and managers whose primary jobs involve extracting and editing knowledge from those who have it"* [168]. "Extracting knowledge" sounds rather painful, not to mention inaccurate- knowledge is not removed from the original owner- the author of this thesis prefers the term knowledge transfer.

#### 2.7.1.2 *Interpersonal knowledge transfer*

The same work [168] describes an incident where a tunnelling team in the USA wanted to make use of innovations from a similar project in New Zealand. After unsuccessful attempts to communicate through documents, members of the New Zealand team met with the USA team and discussed it *"over rounds of Fosters lager"*, resulting in the Americans successfully applying the New Zealanders' innovations. Many participants in the work presented in Chapter 3 declared an interest in studying the effect of beverage choice on knowledge transfer (various, pers.comm., 2015-2017).

Hansen et al [172] mention an attempt by a manufacturer of printing and copying equipment to replace their technicians with an 'expert system' guidance interface for users. Its failure was blamed on the inability of the system to *"capture the nuance and detail of face to face conversations"* between technicians, who regularly engaged in informal discussions. Leonard and Swap [167] discuss examples of tacit knowledge manifesting as an instinct or feeling rather than conscious awareness of pattern matching, though these can be identified after the fact. Potter's aforementioned work [4] with expert laminators also shows how interpersonal knowledge transfer can be useful. A database of layup techniques can cover only that which has been attempted previously, but direct discussion between laminators and designers may inspire new ideas.

#### *Know-Who and Experts*

Leonard and Swap [167] discuss 'Know-Who' as *"Knowledge Once Removed"*. Interpersonal knowledge transfer works only if the expert is willing to share it- something Ghaziri and Awad [169] found to be a major stumbling block- and able to do so well. Knowledge maps [171], [173], both internal to a company and within a larger community, can include directories of experts [171] and are an example of using codified knowledge to facilitate interpersonal knowledge transfer. Nousala et al [174] point out that people need to quickly identify and find the expert with the knowledge they need- and to know that this knowledge will be transferred to them.

Ghaziri and Awad [169] stress the importance of personality in knowledge transfer, referring to experts as *"moody, picky perfectionists"*. This generalisation does not and cannot apply to all experts, but personality is important when studying knowledge transfer within an organisation- the best person to answer questions may not always be the person with the most expertise.

Davenport and Prusak [168] point out the importance of reciprocity in knowledge exchange- the idea that a person will only invest in an interpersonal connection if they get something in return. Helms et al [175] suggest that an expert who teaches a novice cannot expect to gain much knowledge in return, and hence that a reciprocal connection where an expert learns from a trainee is an inefficient use of time. In the author's opinion this neglects the value of a new perspective from the trainee, who may have a very different background, or expertise in a different area- though Ghaziri and Awad's 'moody expert' [169] might fail to appreciate such things. Davenport and Prusak consider the recognition of expertise and enhanced reputation as a suitable reciprocal exchange for the knowledge imparted to the novice. Helms et al [175] found a positive correlation between reciprocity in a knowledge network and group performance (based on questionnaire answers) in the organisation they studied, contradicting their hypothesis, though the statistical significance is not stated and the work was carried out with one organisation only.

### 2.7.1.3 Codification or Personalisation?

Moteleb and Woodman [176] discuss different approaches to analysing and working with knowledge, categorising them as shown in Figure 2.40. This demonstrates the breadth of areas to consider when managing knowledge- for example, a business which approaches knowledge management as a matter of codification misses out on all actor-based knowledge.

When analysing a knowledge repository; if a business relies only on what is already codified they may miss hierarchical relationships between items in different areas. Potter’s taxonomy of defects [26] is an example of such a hierarchical approach, as it classifies defects by how they arise.

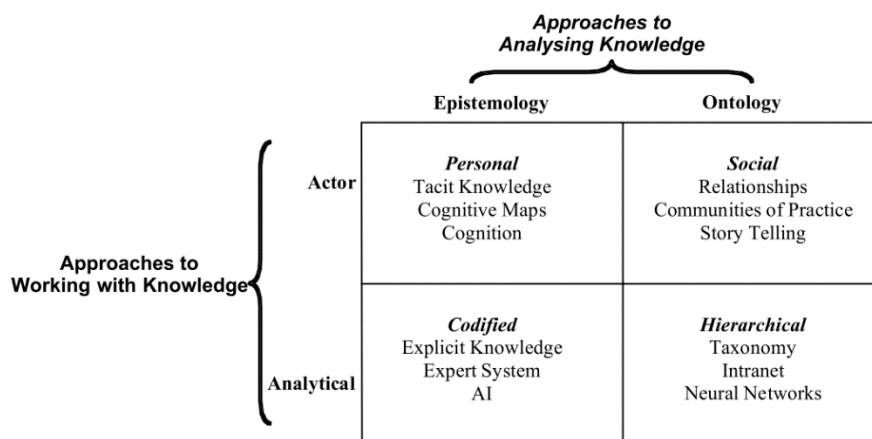

Figure 2.40: Moteleb and Woodman’s Knowledge Management Modelling Matrix. Reproduced from [176]

Hansen et al [172] discuss the ‘working with knowledge’ aspect in more detail, framing it as a choice between codification and personalisation. A “people to documents” codification strategy can ensure useful information is kept in a business- for example, where in-house software is well documented- including clear and thorough commenting of the code- it should not be necessary to disturb the developer’s retirement when moving to a new operating system. Poorly documented fixes can cause major problems if something changes. [177], [178] A personalisation strategy, where conversations, mentoring and brainstorming sessions are the focus, can facilitate transfer of knowledge which cannot easily be codified. Codification may focus on identifying who to talk to for a particular topic, as in Davenport and Prusak’s knowledge access projects and knowledge maps [168] and Leonard and Swap’s know-who concept [167].

Hansen et al [172] state that the consulting companies they studied all used a mixture of these two strategies. They assert that companies which use knowledge ‘effectively’ choose one of the two strategies as their primary approach and uses the other in support of this, as an 80%:20% split, finding that companies which attempt to do both equally are more likely to fail, though they do not cite any data to back this up.

Nousala et al [174] point out the importance of combining both, as personal knowledge may be required to access explicit knowledge. They suggest that people in an organisation should know:

- *“what knowledge is needed*
- *who may know the answer*
- *where explicit knowledge may be found*
- *why particular knowledge is important or why it was created*
- *when the knowledge was last needed or may be needed in the future*
- *how to apply the knowledge.”* [174]

Both the incentives required to encourage staff to participate in knowledge transfer and the IT requirements can be very different for each of the two approaches. Choosing whether to use codification to support a personalisation-centric knowledge strategy or vice versa fits with Davenport and Prusak’s first codification principle [168], deciding on business goals.

Hansen et al [172] conclude that three aspects contribute to the decision. If a company’s products are standardised, codification allows easy reuse of previous work, whereas customised products vary so a personalisation approach may help to deliver each customer’s unique requirements. They recommend codification for mature products, and personalisation where the business strategy relies on innovation. Finally, they ask whether staff rely on explicit or tacit knowledge? Any knowledge management system depends on staff using it, so must fit with working practices.

### 2.7.2 Learning Organisations

Senge [179], describes a learning organisation as “where people continually expand their capacity to create the results they truly desire, where new and expansive patterns of thinking are nurtured, where collective aspiration is set free, and where people are continually learning how to learn - together.” For an organisation to be successful, it is not sufficient to follow the ideas of senior management- learning must take place at all levels inside the organisation, requiring a combination of individual employee, team based and whole organisation approaches. [179], [180]

Garvin [181] takes a more practical approach: “A learning organization is an organization skilled at creating, acquiring, and transferring knowledge, and at modifying its behaviour to reflect new knowledge and insights.” A later work by Garvin et al [182] emphasises creating knowledge faster than the competition, echoing Senge’s “the only sustainable source of competitive edge is your organisation’s ability to learn faster than its competitors” [179].



Senge [179] suggests five disciplines must be considered:

- Systems Thinking; a holistic, 'big picture view', seeking to understand cause, effect and feedback in the organisation and relevant connected bodies as a whole. As discussed previously, defects in a composite part may not be solvable by the manufacturing team – it could be inevitable consequence of the design [26]. Systems thinking requires consideration of the whole process and all contributing factors. This ties into a key problem in organisational learning- if an individual does not encounter the consequences of their decisions, they cannot learn from experience. Where different functions are restricted into silos, without communication between them, this 'learning horizon' problem will likely arise.
- Personal Mastery; in the sense of "master craftsman", through lifelong learning and focus on a personal vision of the individual's aspirations. Without learning at the individual level, the organisation cannot learn as a whole.
- Mental Models; related to Scott's interpretation of 'gestalt' [166], this is framed as an awareness of personal bias and how this can affect the conclusions a person draws.
- Common Shared Vision; "as opposed to the all-too-familiar "vision statement"" [179] is a shared picture of the future the organisation is working to create. It is intended to inspire dedication rather than produce prescriptive rules. The 'shared' aspect is important- an executive imposing their own personal goal may not become shared within the company.
- Team Learning; a team as a whole may achieve insights and results that the constituent individuals working alone could not. This reflects the importance of interpersonal knowledge transfer described above [168], [172]: through dialogue, not only do individuals learn from each other but the team may learn as a whole.

Garvin [181] lists three factors needed to build a learning organisation: "1) a supportive environment, 2) concrete learning processes, and 3) leadership that reinforces learning". These are demonstrated in Sugarman's case studies [183], particularly the product launches example. Admitting mistakes requires all three of Garvin's factors to be present so that staff feel comfortable. Systems thinking was needed to make useful changes for all future product launches rather than local fixes in each product team, moving past the learning horizon.

### 2.7.3 Knowledge Audits

Taking an inventory of the knowledge present in an organisation, including codified documents and networks of interpersonal connections, is referred to as a *knowledge audit*. This can be useful for a business, for example to monitor capability, find gaps in required knowledge, or produce a knowledge map [168] - something which points to where to find knowledge. This might for example be a directory of experts, locations of documents, a searchable database or some combination. [167], [171], [173] It is often recommended [184], [185] that knowledge audits be carried out before embarking on a project to implement new knowledge management processes.

Levantakis et al [184], quoting in 2008 from a variety of sources, suggest that the majority of companies in Europe have some form of knowledge management initiative underway- and that 80 percent of knowledge management projects “*have little or no impact on the organisations*”. Without context, these figures should of course be viewed with scepticism, but the principle of understanding the current situation- and finding out what is most likely to be used by staff- before going ahead with a new solution seems in the author’s opinion most reasonable.

To facilitate knowledge transfer between academia and industry, it is useful to find out how people in these groups prefer to learn. The fourth of Davenport and Prusak’s principles of knowledge codification is identification of an appropriate medium for distribution [168]. The working practices and preferences of the target audience for the knowledge transfer should inform this choice.

In their 2013 review, Shukor et al [185] compared 22 papers mentioning “*process*”, “*output*” and “*data gathering technique*” for knowledge audits. The four most popular techniques among the papers they studied were questionnaires (7 papers), interviews (8), document review (3) and “*focus groups and observation*” (3). This includes groups using more than one of these. As this is a limited set of papers one cannot draw statistical conclusions on the relative popularity of, say, document review versus questionnaires, but these techniques are all used by more than one group.

They do not find a standardised process for carrying out a knowledge audit. Some groups consider recommendations, implementation and re-auditing part of the process, others discuss only the inventory/mapping process- of both documentation and knowledge flow between people. Some of the papers cited in the aforesaid review [185] attempt to create a standardised method for knowledge audits [184], [186], [187].

It seems based on these that the only agreement is that a knowledge audit involves designing a new ‘standard’ method.

Shukor et al [185] find more agreement in the expected outputs of a knowledge audit, with 18 papers mentioning an inventory of knowledge assets and 15 some form of “*knowledge exchange path*”, identifying the flow of knowledge among people. 7 papers were categorised as using the knowledge audit as a ‘diagnostic tool’- for identifying knowledge gaps. Directories of experts (4) and training needs analyses (2) were also possible outputs.

The majority of these works are knowledge audits with industrial groups [31], [173], [174], [184], [187], [188]. In the 2012 paper “*Determining The Existence Of Knowledge Management Processes Among Academicians*”, Nawi et al [189] note that academic groups have been neglected. They found that, for the faculty studied, knowledge management processes (capturing, organising, refining and transferring) occur. There is no mention of standardised procedures or rating their usefulness.

A subset of knowledge audit techniques, related to the human side of knowledge transfer rather than locating documentation, is used in Chapter 3.

This is not intended to trivialise the importance of documentation- on the contrary, ensuring work is both useful and used requires relevant information to be found and understood as part of normal work processes. Reports are of little use if the information they contain is not read, understood and applied to the next project. Rather it is intended to gather opinions on both codified and interpersonal knowledge transfer in the participating organisations, and to identify knowledge transfer occurring within and between them.

#### 2.7.3.1 Questionnaires

Simply asking people for their opinions and who they talk to can seem a very obvious approach, yet among the participating organisations in Chapter 3 it was not common practice to do so.

##### *Quantifying opinion*

Hubbard [190] suggests methods for measuring ‘soft’ qualities such as opinions and happiness.

- 1) Likert Scale- rating on a scale from ‘strongly agree’ to ‘strongly disagree’ or ‘strongly like’ to ‘strongly dislike’.
- 2) Multiple choice- picking from mutually exclusive answers.
- 3) Rank order- assigning numbers to a list of items from most preferred to least preferred
- 4) Open ended- space to write an answer in the participants’ own words.

All except the last option can then be quantified by measuring how many participants (or how many with a set characteristic, such as job type) answered in each way.

Hubbard [190] makes a point of recommending strategies to avoid bias. Short and precise questions are recommended, without compound parts (e.g. 'do you prefer A,B&C to D,E&F?' would be difficult to answer if you prefer A to D but E to B). It is best to avoid loaded terms and leading questions if you wish to obtain a genuine and unbiased result. The guide also recommends reversing values in scale questions sometimes so that people do not just automatically tick 5 (or 1) for everything. These practices have been followed in the questionnaire used in Chapter 3.

### 2.7.3.2 Knowledge Network Analysis

Knowledge networks are a form of social networks, where connections between individuals are displayed in a graphical form and analysed. Scott [166] describes the initial concept as a 'sociogram', a map of social connections. A popular person is, in sociometric concepts, referred to as a 'star' due to the inward links surrounding them from admirers who aspire to be their friend (Figure 2.41).

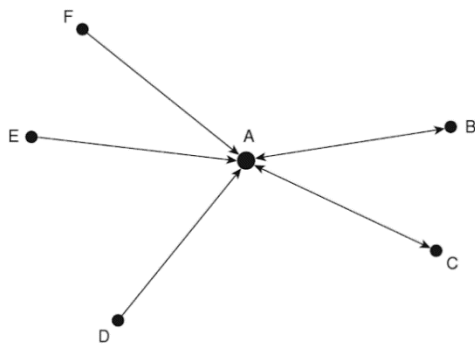
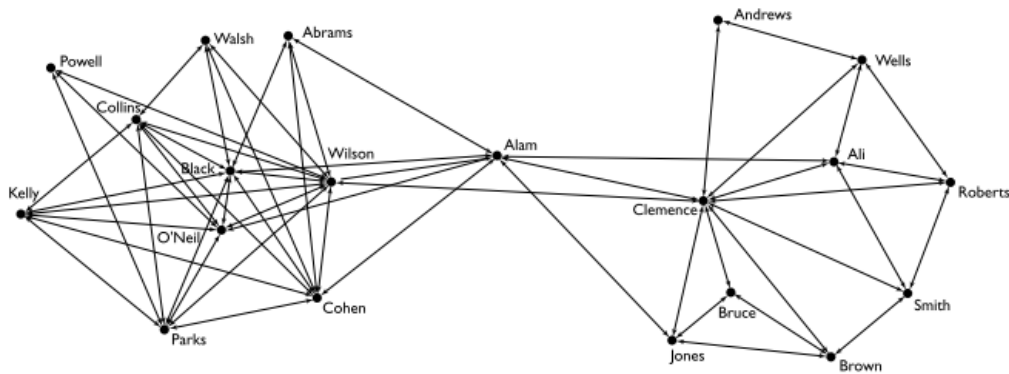

Figure 2.41: An example of a sociogram- a sociometric star. Reproduced from [166]

The links between people, or edges, in a sociogram are directional, so may be reciprocal- or not. For a knowledge network, the edges represent knowledge transfer in an organisation. These may be useful in understanding the knowledge flows within a group or organisation; and can identify problems which may not otherwise have been noticed. An example from Cross et al [191], shown in Figure 2.42, illustrates knowledge flows in a specialist group of experts within a consultancy. The initial study found two sub-groups of people who chose to work together due to shared interests. This had become a problem as members of each group were not drawing on the expertise of the other in their projects. With the problem illustrated, the group leader staffed projects with persons from both groups and implemented new goals and communication tools which required interaction between the groups. The second study shows a far more robust network.

### Pre-Intervention



### Post-Intervention (Nine Months Later)

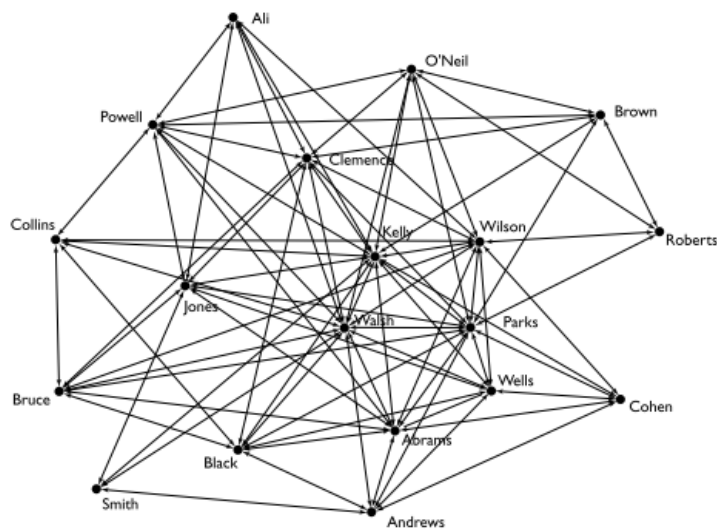

Figure 2.42: Sociograms of an expert consultant group, reproduced from [191]. Names are disguised.

Helms et al [31] divided knowledge networks into two types- 'push' networks, representing teaching of one or more persons by others, and 'pull' networks, representing the asking of questions.

Edges in a sociogram may be weighted. For a pull network this might be by frequency of questioning, as used in Chapter 3. For a push network edge weighting represents how active the learning is, on a scale from very passive (e.g. listening to a lecture) to very active (e.g. guided experimentation). [31] Davenport and Prusak [168] refer to this concept as "*viscosity of knowledge transfer*", considering it a measure how much will be retained by the learner.

Networks, of any variety, can be analysed in many ways depending on the requirement[166]. The principle of nodes connected by edges might describe companies, people, web pages and hyperlinks, computers, airports with connecting flights or many other things. Network visualisation and analysis tools such as Gephi [192] or UCINET [30] can be used to generate sociograms and to analyse various aspects of the networks mathematically. Focusing on knowledge transfer, it is useful to discuss the splitting of a community into cliques [166] as this can affect knowledge flow. Measures for the authority of any given node- here a person- are also useful, as this can help to identify the experts who are communicating their knowledge to others in the group.

### *PageRank*

Brin and Page [193], [194] developed the PageRank algorithm to use hyperlinks- edges- to determine the authority, or rank, of web pages. Their concept, that a node's value is determined by the value of the nodes that link to it, should result in both a node with many links pointing to it and a node with a single link from a highly ranked node having a high rank. This method is famous as the original basis for the Google search engine[194].

A simplified version of PageRank [193] defines a ranking  $R$ , for a node  $u$  with outgoing links to a set of nodes  $F_u$  and incoming links from a set of nodes  $B_u$ .  $N_u=|F_u|$  is the total number of links from  $u$ .

$$R(u) = \sum_{v \in B_u} \frac{R(v)}{N_v} \quad (2.43)$$

$c$  is a normalisation constant. The rank of a node is defined by the sum of the fractional ranks from incoming links. This rank is then divided equally among the outgoing links to contribute fractional ranks to the nodes they point to.

This simple method allows rank sinks to form: where two nodes link only to each other, but one has an incoming link from elsewhere, rank accumulates by looping between the two paired nodes. This is solved by introducing a damping factor [193], [195],  $d$ , usually set to 0.85. For web users, this represents randomly surfing without following a link.

$$R'(u) = (1 - d) + d \sum_{v \in B_u} \frac{R'(v)}{N_v} \quad (2.44)$$

Gephi implements a modified version of PageRank which takes into account edge weighting[196].

### *Hypertext Induced Topic Selection (HITS)*

The HITS approach [195] ranks nodes by incoming and outgoing links. Nodes linked to by many other nodes are referred to as *authorities*, whereas nodes which link to many other nodes are called *hubs*.

Based on Kleinberg's work [197], the Gephi implementation assigns an authority value and a hub value to each node, each normalised over the network so that their squares sum to 1. Both values are first set to 1. Each node's authority value is updated to be the sum of the hub values from the nodes pointing to it. Each node's hub value is then updated to be the sum of the authority values of the nodes it points to. Both sets of values are normalised, and the process repeated.

### *Modularity classes, or cliques*

Networks can be partitioned into cliques or communities of densely connected nodes, where the connections between cliques are more sparse. [166], [198] Splitting a network into these cliques can demonstrate whether they line up with the expected- e.g. teams within an organisation- and whether or not there is sufficient knowledge flow between cliques. A network partition has a property called modularity- this is a measurement of the density of links inside cliques compared to those outside cliques, which takes a value between -1 and +1 [198]. Modularity is optimised to produce the optimum partitioning of the network into cliques, referred to as modularity classes.

Gephi uses an algorithm based on the work of Blondel et al [198]. For a network with weighted edges  $A_{ij}$  between nodes  $i$  and  $j$ , where  $k_i = \sum_j A_{ij}$  is the sum of the weights of the edges from node  $i$  and  $c_i$  is the clique containing node  $i$ , they define modularity,  $Q$ , as:

$$Q = \frac{1}{2m} \sum_{i,j} \left[ A_{ij} - \frac{k_i k_j}{2m} \right] \delta(c_i, c_j) \quad (2.45)$$

The  $\delta$ -function,  $\delta(u,v)$ , is 1 if  $u=v$  and 0 otherwise and  $2m = \sum_{ij} A_{ij}$ .

Blondel et al [198] use an iterative process over first nodes, then cliques, to find high modularity partitions of networks.

Finding the cliques and enabling knowledge transfer between them is of value to an organisation, as if work is done only in isolated silos this can result in duplication of effort, where solutions to problems are not shared across the whole organisation.

### *Knowledge networks between academia and industry*

Knowledge networks of many organisations commonly use organisations as nodes rather than individuals. This may represent links between companies but cannot automatically be assumed to imply transfer of knowledge at the individual employee level.

Studies carried out investigating knowledge transfer links between different organisations in the same space commonly use either proxy data; such as lists of partners on websites [199], co-publication of papers [200], collaboration on research projects [201] or membership of meetup groups [202]; or interviews with single representatives of each organisation, usually Chief Executive Officers (CEOs). In the former case, while the organisations have a declared partnership there is no demonstration of knowledge transfer between individual employees.

Where CEOs or other executive officers are interviewed, they may be explicitly asked to identify knowledge transfer links as in Plum and Hassink's study of automotive and biotechnology companies in two regions of Germany [203]. While this still fails to assess knowledge transfer at the employee level, if the CEOs are in touch with the day to day work going on in their companies this may be more realistic than some of the proxies listed above. Plum and Hassink [203] found that almost all biotechnology companies interviewed had links with universities or research institutions but very few of these academic institutions were linked to more than one of the companies interviewed. A smaller proportion- but more than half- of automotive companies had links to research institutions or universities and more of these institutions had links with multiple companies.

In other industries, the method of interviewing single representatives of each company also shows links between research institutions and companies. Abbasiharofteh and Dyba [204] found furniture SMEs participating in a cluster initiative in Swarzędz, Poland, all had direct links to at least one research institution. Similar companies in Kępno, Poland, who were not part of an official initiative were all linked either directly or via another company to a co-operating institution [204].

Hjertvikrem and Dahl Fitjar [205] carried out interviews with representatives of 30 subsea companies in Rogaland, Norway, of which 23 were considered small or medium companies. They found multiple links between companies, and the majority of companies had links to one or more universities or research institutions.

In their study of the wine industry in Mendoza and San Juan; Argentina, McDermott et al [206] interviewed enologists and agronomists- knowledge workers at wineries and grape suppliers- alongside directors, presidents and other high-level individuals, plus staff members at Government Support Institutions (GSIs), which have a remit to provide training and R&D programmes in this industry. Participants were asked to identify sources of knowledge, but at the organisational level rather than naming individuals. The local government in Mendoza had created numerous GSIs to support the wine industry, while San Juan took a different approach. The resulting knowledge network can be seen in Figure 2.43.



They found links between all participant wineries and GSIs in both areas, but a larger number of wineries and GSIs in Mendoza forming a network with a core group of wineries with links to multiple GSIs and GSIs with links to numerous wineries, surrounded by organisations with only one or two links. In San Juan the number of both institutions is smaller, and only one winery has links to more than two GSIs. Three GSIs link the two regions. There are no wineries that do not have links to at least one GSI [206].

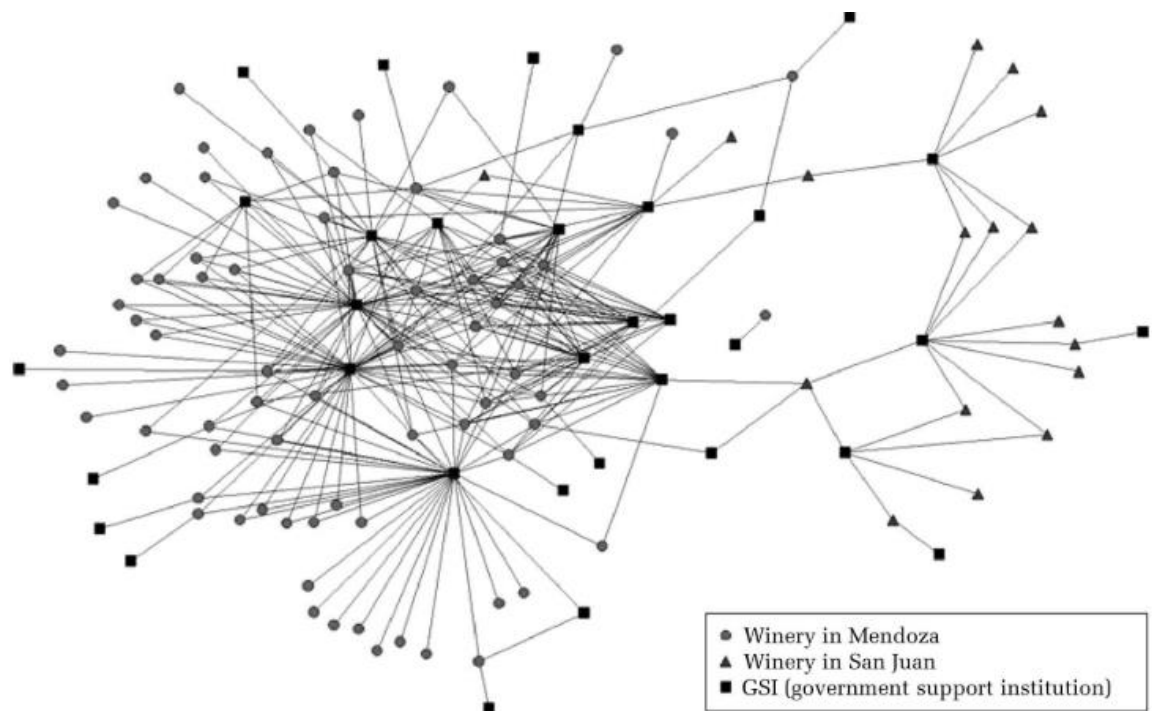

Figure 2.43: Ties between wineries and Government Support Institutions in Mendoza and San Juan, reproduced from [206]. Data based on interviews with a range of staff members carried out in 2004-05. [206]

#### 2.7.4 Technology transfer and SMEs

*“Practices and rules developed very early in the history of composites, when the materials were new and untried, are still widely used across the breadth of composites applications despite the availability of new knowledge. This old mindset around composites is evident when we consider current production capability issues.”*

The above quote from Chatz Michali and Potter [207] demonstrates the importance of knowledge transfer in development of a new technology, specifically in the composites industry. They state that when integrating new technology into a business without accompanying knowledge transfer, the new technology will likely be treated as a ‘black box’ and hence not be used to its full potential.

Fabris et al [208] find that the majority of programmes for technology transfer from academia to industry which are relevant to composites manufacturing target aerospace and defence, mostly large companies. Their report, which focuses on the Canadian composites industry, states that over half of the companies (mostly SMEs) surveyed either invest less than 5% of revenue in research and development or do not carry out R&D at all. The same group have pioneered 'Knowledge in Practice Documents' [115], a structure for industrially focused knowledge transfer in the composites industry, splitting information regarding the topic in question into categories relevant to the manufacturing process: equipment, tooling, part, materials and methods and producibility. Providing such knowledge transfer fits with the push-to-market approach for radical new technologies recommended by Maine and Seegopaul [209].

López-Gómez [210] points out that limited resources makes capitalising on scientific development particularly difficult for small and medium sized enterprises, while arguing that they are vital to the UK economy.

Dowling's review [211] finds business-university research collaborations vital to technology transfer, including the Catapult scheme, of which the National Composites Centre is a part. The review emphasises the difficulties faced by SMEs in accessing and benefiting from university research. Recommendations include more effective brokerage in arranging collaborations, prioritisation of *"knowledge exchange over short term income generation"* and greater recognition of the importance of people in successful collaborations for knowledge transfer.

#### 2.7.5 Knowledge Matters

Hansen et al [172] conclude their paper with an exhortation not to isolate knowledge management. The choice and implementation of a strategy must be led from the top and embedded into the business- not as an add-on but a key part of all activities.

Davenport and Prusak [168] also discuss this in terms of the 'knowledge environment' in a business, in particular in terms of building knowledge management into business processes and employee activities and appraisals. They consider knowledge an asset to a business *"as real as any other that appears on its balance sheet"*.

The author's experience bears this out, as does Potter's [4] discussion of how skilled laminators' knowledge can contribute to designing parts which are easier to manufacture, delivering better quality or greater efficiency- this requires knowledge transfer between laminators and designers. Similarly, in technology development, knowledge transfer should, in the author's opinion, be a key constituent of the process.

Within an organisation, sharing knowledge both increases robustness and can spark new ideas through conversations with others. Zack [212] states *“integration of knowledge across different contexts opens an organisation to new insights”*. One of the goals of Joel-Edgar and Gopsill’s [170] document tagging and linking project is to find hitherto unknown links between disparate projects. Someone in a different team, trying to solve a different problem, may have coincidentally found something useful to you. This can be generalised to communities of practice across many organisations- an aspiration to develop composites manufacturing technologies in a manner useful to a variety of industries, and sharing this knowledge across sectors, is part of the reason the National Composites Centre exists. Another reason is to bridge the gap between academic research and industrial application- two groups who may not share the same framework, language or methods of communication.

Technology transfer requires the benefit of the technology to be communicated to the industrialists who will use it, in a manner which suits their preferred methods of learning. The low industrial uptake of dielectric cure monitoring may be an example of failure to transfer knowledge from academia to industry. On a wider continuation of the theme, academics and industrialists alike benefit from improved public understanding of their work, removing the scare factor from the unfamiliar and demonstrating utility to society, along with- hopefully- encouraging more people to consider careers in these areas, particularly important in areas- such as composites manufacture- where a skills gap [33], [213], [214] might easily act as a dampener on an otherwise growing industry.

## 2.8 Review Conclusions

### 2.8.1 Knowledge transfer within and between academic and composites SMEs

In order to improve knowledge transfer between academia and industry, it would be useful to know knowledge workers' preferences, opinions on current practices and to find out the current status of knowledge transfer links between the different types of organisation. For each individual organisation, the opinions and preferences combined with an illustration of current knowledge transfer and expertise can highlight both problems and opportunities.

Knowledge held within the minds of employees is valuable to any organisation. Some things can be codified, but interpersonal knowledge transfer is often preferred, particularly when dealing with tacit knowledge. [4], [162], [163], [166]–[169], [172] This is vital for team learning, and communication beyond the team to expand horizons and solve problems holistically. [179]–[183]

There is no standard practice for carrying out a 'knowledge audit' of both the codified material and interpersonal connections within an organisation. [184], [185], [187], [188] These exercises, using a variety of methods, are more often carried out with industrial groups [31], [173], [174], [184], [187], [188] than academia [189]. Questionnaires can be used to quantify opinions using a Likert scale, rank order or similar. [190]

Knowledge networks can illustrate the connections between individuals [30], [166], [192]. Helms et al [31] divide these into 'push' networks, where one person is taught by another, and 'pull' networks- asking of questions. The network edges can be rated by viscosity of knowledge transfer- where more active learning is more likely to 'stick' [31], [168]. Knowledge networks can be analysed using methods such as PageRank [193]–[195], HITS [195], [197] and modularity classes [166], [198].

Studies of knowledge transfer between organisations commonly use proxy measures such as lists of collaborators [199]–[202], or conduct interviews with CEOs [203]–[205]. These studies show links between companies, including SMEs, and universities/research institutions in a variety of industries, but do not ask the individual employees if they learn from these links. One study which does ask knowledge workers with the companies, McDermott et al [206], finds many connections between 'government support institutions', which conduct research and training, and companies in the wine industry in Argentina.

A questionnaire based study is carried out to find out employee opinions regarding both current knowledge transfer practices and other options in academic groups, a research institution and companies- mostly SMEs- recommended by these. These same questionnaires ask participants who they learn from and who they go to with questions, allowing knowledge network diagrams to be constructed, illustrating knowledge transfer pathways both within and between organisations.

### 2.8.2 Using micro X-ray CT scanning to track defects

Monitoring tow gaps and ply drops during cure, using uninterrupted in-situ micro-XCT, would be useful to industry and may deliver a clearer picture of void evolution. This is also intended to demonstrate in-process micro-XCT as a technique which may be useful during product development.

Tow gaps and ply drops are unavoidable for AFP layup of many geometries [4], [7], [151]–[153]. These defects have negative effects on the final properties of a part [153], [155], [156] and the position of the defect in a part can have a significant contribution [48], [154]. As tow gaps are in line with the fibre direction, fibre movement into the gap during cure is expected as in Belnoue et al's model [151] which is not expected with ply drops.

Tow gaps and ply drops result in voids at the site of the defect. The initial voids located at the defect sites are large, but smaller voids which remain or form later in the cure may be described by the model of de Parscau du Plessix et al [160], which predicts an increase in void radius as resin viscosity decreases and temperature increases. XCT studies using multiple quenched samples do not show an increase in porosity at this stage [27], [28], but here the same defect is not tracked throughout so variation in the initial state cannot be accounted for, and details may be missed as relatively few scans are taken.

A cure kinetics model for the Hexcel M21 resin [15] can be used to model the viscosity and degree of cure [43]. Voids can be measured in XCT reconstructions using a surface determination method based on the change in greyscale value between the material and air in the reconstructed volume. [141], [142]

Time-resolved XCT is often carried out using a synchrotron [136], [144]–[148], including a study of void evolution during debulking (without cure) [147]. Industrial micro-XCT scanners cannot achieve the same scan speed and resolution, but have been used for uninterrupted in-situ time resolved XCT [149] though, prior to this work, no records could be found of in-situ micro-XCT scans of a composite part during cure. Bubble transport during the cure of neat resin was studied in a time resolved manner using a nano-focus XCT scanner [150].

An industrial micro-XCT scanner, equipped with a heated tool and vacuum system, is used to take fast scans of composite parts during cure. To achieve the best possible resolution, a small cylindrical part is preferable. Unidirectional M21 prepreg can be laid up with a deliberate defect- tow gap or ply drop- across the diameter of a test part. Total void volume for each scan can be measured using a surface determination routine and automatic processing in VGstudioMAX. These results can be compared to the viscosity and degree of cure of the part using the M21 cure kinetics model, to determine whether the predicted increase in void volumes at minimum viscosity is seen.

### 2.8.3 Dielectric analysis for monitoring degree of cure

Dielectric Analysis is required to monitor the degree of cure and  $T_g$  of a test part throughout different cure cycles in an industrial autoclave, and to trigger the cool down of the autoclave when the required degree of cure is reached in both thin and thick extremes of the part, with the intention of delivering a lower energy cure cycle for this demonstration part.

The applicability of dielectric analysis to monitor the degree of cure of a resin has been demonstrated through comparison to DSC data [20], [86], [94], [101], [105], and to other cure monitoring technologies- ultrasonic cure monitoring [86] and FTIR spectroscopy [67]. For a dynamic cure cycle, the time derivative of the logarithm of the Imaginary Impedance Maximum can be analysed in an analogous fashion to a DSC trace, demonstrated by Skordos and Partridge[105]. The Advise dielectric analysis system [34] uses this approach and has a model for the Hexcel 8552 resin. The glass transition temperature,  $T_g$ , can be calculated from degree of cure using the DiBenedetto equation[40], [42]. For the Hexcel 8552 resin [13], the DiBenedetto equation from the NCAMP cure model [23] is used by the Advise system to calculate  $T_g$ . This equation does not account for a drop in  $T_g$  seen at very high degree of cure, caused by degradation of the resin [23].

The NCAMP model for 8552 [23] also includes a cure kinetics model, allowing a theoretical degree of cure to be calculated from temperature data. This model is used in the Raven software[44].

A range of sensor options exist [17], [19], [92], [34], [54]–[57], [76], [81], [90], with interdigitated sensors being the most practical for use in autoclave cure [84], either as tool mounted or embedded sensors. Embedded sensors are required to measure at a point within the thickness of a ply stack.

Maistros and Partridge [84] have used dielectric analysis to identify the optimum time to apply pressure during cure of a stepped wedge test part with a range of thicknesses. Dielectric analysis has also been used to suggest changes to cure cycles to enable out of date prepreg to be used [25], though this work did not include active process control.

The test part is made of 8552 as models are available for both the dielectric analysis system and the simulation software, which use the same degree of cure- $T_g$  relationship. Measurements of degree of cure and  $T_g$  by the dielectric analysis system are compared to simulation and to DSC and DMA tests of samples from the cured part. The choice of target degree of cure should be low enough that when the thin end of the stepped wedge reaches the target, the thick end is expected to be at a measurably higher degree of cure, to ensure a range of measurements, while not being so low as to be unrealistic for all industrial use. Active process control of the autoclave by the Advise dielectric analysis system is trialled as part of this study. Flexible sensors are assessed for their suitability in an industrial environment.

#### 2.8.4 Knowledge Transfer Resource for Dielectric Cure Monitoring

An industrially focused knowledge transfer resource for dielectric cure monitoring is intended to illustrate potential uses of the technology which would be of value to a manufacturer of composite parts, while providing useful information, including practical considerations, which should be evaluated when making a business decision.

Dielectric cure monitoring has been used in academia for decades, but is little known in industry. [19], [20], [97], [215] This technology has a variety of potential applications in composites manufacturing. Cure monitoring for quality assurance and active process control for cure optimisation are discussed above. Other applications include increasing the usable lifespan of prepreg [25], tracking resin flow fronts [116] and controlling the flow to eliminate dry spots [24], determining the best time to apply pressure during the cure [84] and monitoring degree of cure through the thickness of an aerospace component [76].

Knowledge transfer can be important in facilitating adoption of new technology, both in ensuring it is used to its full potential [207] and as part of a push-to-market commercialisation strategy [209]. Business-university research collaborations are considered vital to technology transfer from academia to industry [211], which is of particular value to SMEs, which have limited resources but contribute to the economy, though large companies are often targeted. [208], [210]

A resource of codified knowledge should be designed to fulfil clear goals. It should exist in an appropriate medium for distribution and consider not just the content, but how best to structure and communicate it. [168], [169], [172], [176] Use of language is important, as academia and industry or even different departments within the same organisation may use different jargon [4]. Knowledge codified in this manner may easily become out of date, so something easily updated- such as a software portal- should be considered [169], [171]. Fabris and Poursartip [115] have pioneered a structure for 'Knowledge in Practice Documents' based on the needs of the composites industry.

A Knowledge Transfer Resource for dielectric cure monitoring is constructed, with reference to the results of the Knowledge Transfer Study questionnaires. This is designed around industrial requirements and includes case studies. An electronic format allows easy updating and integration of multimedia elements, plus non-linear navigation, allowing users to follow the path most relevant to them and to jump to a glossary easily if needed.

# Chapter 3

## 3 Knowledge Transfer in Academia and Composites SMEs

### 3.1 Rationale

A technology may be well known in academia yet never make it to industry, despite its promise. Dielectric cure monitoring is an example, having been used in academia for over three decades [78], but with little uptake in industry. Commercial systems are available [34], though not yet truly mature. Encouraging industrial uptake requires not only technological development but also knowledge transfer. Potential industrial users need to be aware that the technology exists and might benefit them, to learn about it in a manner which suits the way knowledge is transferred in industry.

Both the National Composites Centre and the EngD in Composites Manufacture aim to bridge this gap between academia and industry, making this topic of particular interest for an EngD undertaken at NCC. The EngD scheme is notably based around people- by carrying out a doctorate in an industrial environment, EngD students- such as the author- sit between the worlds of academia and industry and are well placed to introduce new technologies into the industrial environment, while feeding back to academia the requirements of industry in these areas, and presenting their work in an academic environment. The NCC exists to drive the UK Composites industry forward, contributing to the economy both with technology and building a skills base for the future. This involves working with industrial partners to carry out research of use to a variety of companies and industries, to develop new technologies and, particularly through links with the University of Bristol, bringing academic work to higher TRL levels [216] and the attention of industry. The skills aspect is particularly important. As detailed in the Perkins Report [214], the UK has a large skills gap in Engineering. We do not have enough new Engineers to replace the generation reaching retirement, let alone to develop in new areas- Composites being a key growth area [2]- and hence improve the UK economy as the government intends. Tackling this gap is very important [213]. In the long term, the way we teach physical sciences and technology in schools- particularly to girls, as relatively few women still choose engineering- will be key to this, as argued in this 2014 essay [33]. In the meantime, efforts at NCC to provide training to those already in engineering with no composites experience are vital to this task. The courses are a collaboration between academics and NCC staff, aimed squarely at those with an industrial background. It is intended that the results detailed here may contribute to delivering this knowledge transfer in the most useful manner.



Hypothesising that there may be significant differences between knowledge transfer in industry and academia, a survey was designed to find out more about this, focusing on composites SMEs and comparing them to two academic groups. The survey is designed to be useful to the organisations, with the results providing information which may inform business decisions, including how they organise their internal knowledge transfer.

## 3.2 Knowledge Transfer Studies

### 3.2.1 Aims

A questionnaire based study has been developed, intended to facilitate better understanding of how knowledge is transferred in the composites industry, with a particular focus on Small and Medium-sized Enterprises (SMEs) of less than 250 staff [217]. SMEs are often considered more agile [211] than larger businesses, with smaller scale processes and/or batches of different items built on demand. This suggests that SMEs might find it easier to experiment with using new technologies in their processes than large companies, particularly those with long development cycles as are common in the aerospace industry. However, a small company is often too small to have a dedicated research and development team. [210]

In order to encourage technology transfer from academia to industry, it can be useful to better understand knowledge transfer in these two areas. The hypothesis that few industrial participants will read academic papers may seem like common sense- for many businesses cannot afford the subscriptions or the staff time required- but this does not make it any less valuable to find out what is popular and what is not, how business practices compare across the participating organisations, and whether there are any correlations with age or job type in how people prefer to learn or find answers to questions.

Additionally, using the model of Helms et al [31] to construct network diagrams for knowledge transfer between participants- within and between the groups- gives us an indication of how successful an organisation's current practices are and an indication of whether or not schemes intended to improve links between academia and industry- such as the EngD scheme and the National Composites Centre- have resulted in any such links being formed among the organisations studied. As the Tier 1 members of the National Composites Centre are all larger companies [5], investigating whether any employees of representative composites SMEs consider NCC staff a source of knowledge may be particularly informative.

### 3.2.2 Value to participating company

For the participating company, which receives a full report on their results (but not anyone else's), it is important that they gain a benefit from being involved. While, as part of a student project, the work was carried out for free, this does not mean it is at zero cost to the company, as staff time to fill in the questionnaires and liaise with the organiser has a value.

The questionnaire was therefore designed not only to be of interest for the topics being studied, but also to be directly useful to the company. The results can be used to identify key people, see who is isolated and to find gaps in competencies needed for projects. This allows a manager to find out where more knowledge transfer may be needed, either from existing experts to other staff or by training people in a new area or bringing in new expertise. Knowing who is an expert, and on what, creates the opportunity to share their knowledge throughout the company, preparing for the day when that expert moves on and encouraging staff to help and learn from each other.

To make the most of this, it is also useful to find out how well the current knowledge transfer practices are- or are not- working, and opinions on what other options might fit well with the organisations. Asking staff what they think, and how they find out what they need to know, provides valuable information when making business decisions about future knowledge transfer practices.

### 3.2.3 Development of questionnaire

#### 3.2.3.1 *First pilot study*

The first stage questionnaire was developed after talking with a capability group at the Research Institution about their requirements and conducting a literature survey. The initial pilot, including knowledge network, competence matrix and opinion based questions, was conducted via the organisation Intranet using SharePoint.

Despite all efforts, the response rate was extremely poor (<10%). Since a representative picture of the group cannot be obtained with such a low response rate, a different approach was needed.

#### 3.2.3.2 *Second pilot study*

The second pilot was carried out with a different group at the Research Institution. In an attempt to encourage the group members to participate, a paper questionnaire was used, and participants were encouraged to do this on the spot during the group meeting. A cake incentive was offered. The response rate was much improved, as almost all group members present on that day participated.

Use of a paper questionnaire makes anonymisation easier, but significantly increases the workload, as the data must then be entered into spreadsheets manually. OCR software was investigated for automation but a suitable solution could not be found. Given the vastly improved response rate, this extra work is considered worthwhile. If more funding were available, a dedicated set of devices that could be handed out at meetings would meet both sets of requirements.

Feedback on the result was very positive. The group manager considered the information provided very useful, particularly the knowledge networks, as this illustrated potential problems he had been unaware of (anonymous group manager, pers.comm., 2015).

### *3.2.3.3 Final questionnaire*

A generic example of the final questionnaire is shown in Appendix 1. Minor improvements were made based on feedback from the second pilot study. The topics in the competence matrix are unique to each organisation, chosen by the representatives who arranged the study- usually managers or team leaders. Among the opinion based question is one asking participants to rate their organisation's current knowledge transfer practices. As some organisations have unique practices, the items on this list can also vary. For later analysis, where possible these were grouped into categories to allow comparison between groups, but some more unique options had no easy point of comparison with others.

#### *Note on anonymisation*

The questionnaire was constructed in two parts. The first, requiring names to serve its function, is used to construct networks of who learns from whom and who goes to whom with questions (following [31]), and a matrix of self-rated competencies. This is anonymised by assigning which are not related to individuals' names (e.g. Participant 1 in group A is PA01).

The second part contains opinion questions about knowledge transfer in the organisation. To encourage honesty, this part is on a physically separate sheet and immediately anonymised (by shuffling the papers) as far as is reasonable. However, it should be noted that in order to investigate trends, participants were asked to give their age range (decade) and job type, meaning that where an individual is very distinct from the others in their group (such as the one person aged under 20) it would in theory be possible for a person who knows participants at that organisation to identify them. No such identification has been or will be attempted.

All participants were issued with a briefing document explaining what the questionnaire was for and how to contact me, including how to withdraw their answers prior to anonymisation. All questions were optional, and some chose not to give their ages and job types.

### 3.2.4 Participating Organisations

The survey was carried out with staff and students from twelve different organisations. Results are most representative of the organisations- and most useful to them- where all or most staff from the company or team are included, but this was not always practical.

9 of the organisations were companies, in the composites industry. Companies 1 – 4 are based in Canada and companies 5 – 9 in the UK.

Company 1: A relatively high-tech manufacturing company, larger than an SME as it has 750+ staff, with sites in two countries. Aerospace industry. 11 participants drawn from a larger workforce.

Company 2: A high-tech SME working on software and hardware for composites manufacture. A spin-out from the Canadian academic group, based on the main university campus. 19 participants, comprising of most of the staff.

Company 3: A small manufacturer using lower-tech methods than company 1, making consumer goods. 9 participants.

Company 4: A second small manufacturer in consumer goods, again using lower-tech methods than those common in high value industries such as aerospace. 5 participants.

Company 5: The composites arm of a holding company. Run mostly as an independent unit, though product design is often done at the head office. Manufacturing large batches of a variety of composite components, including non-structural parts for rail and aviation. 8 participants drawn from a larger workforce.

Company 6: A small business with an interest in new technologies and training and apprenticeship schemes. Manufacturing small batches and one-off projects among other things, with some high-tech items. 18 participants. Notable that two different groups within the business (laminating and fitting) are considered by management to have significantly different working cultures. (Interview conducted with senior staff at Company 6, not included due to anonymisation requirement, August 2016)

Company 7: A small business which has relatively recently (early 2016) been acquired by a larger, though still relatively small (150 people) business. Run largely independently, making batches of components for a variety of customers. Particular expertise in marine systems. 7 participants from a workforce roughly double that size.

Company 8: An SME which develops and manufactures equipment used in the composites industry- including by company 7 and the research institution. 20 participants.

Company 9: A composites engineering group within a large multinational aerospace company. 13 participants, comprising most of the group in question.

A research institution, intended to facilitate technology and knowledge transfer both from academia to industry and throughout the composites industry, was used for the initial pilot studies as well as participating in the final study, approximately 18 months after the second pilot. Four different research groups within the research institution participated.

Two academic groups, one in Canada and one in the UK, also participated. The UK group (Academic 1) is a collaboration between four separate universities which are located in different cities. One of the universities hosts the above-mentioned research organisation. There were 39 participants, all of whom attended a group conference. Some of the participants are EngD students, some of whom are based at the research institution and one at company 7.

The Canadian group (Academic 2) was based at one university with two geographical locations. One of the Canadian SMEs (Company 2) is a spin-out from this university and is based on campus, some people work for both the academic group and the company. There were 13 participants, comprising most of the academic group.

*Important Note:* The author is a member of the Research Institution and Academic Group 1 and spent time with Academic Group 2. The author did not participate in any of the surveys in an attempt to avoid unintentionally biasing the result. Other people who are members of more than one organisation have participated more than once. Their contributions to the knowledge networks are combined from all questionnaires, and duplicate links deleted, with the highest value link saved. For the anonymous data, it is not possible to identify which answers are duplicates so these are simply included. 4 people completed the survey in both the Research Institution and Academic Group 1, person completed the survey in two different groups within the Research Institution and 1 person completed the survey in Academic Group 1 and Company 7.

### 3.2.5 Knowledge Networks

A Knowledge Network shows the connections between people in a group. These can be used to identify the key people (*Knowledge Brokers*) who are engaged in transferring knowledge to others, for example by teaching or answering questions. It is also easy to see if any of the participants are isolated from the rest of the group. Knowledge Network Analysis is a form of Social Network Analysis, an increasingly popular [166], [175], [218] tool for studying connections between people and how those who form a group interact.

This is valuable to a business, as identifying key staff is crucial to retaining knowledge within the organisation- in the short term by ensuring key people are happy to stay, and in the long term by encouraging effective knowledge transfer to others. When a knowledge broker does decide to move on, ensuring that the network is robust enough to withstand the loss and/or hiring or promoting staff who can provide not only the technical competencies but also the personal qualities that make a good knowledge broker are important.

Following the model of Helms et al [31] the first two questions of the survey were intended to construct two different knowledge networks for the group in question, known as Push and Pull networks. A Push network represents teaching of one (or more) people by others. This might for example include taught courses, lectures, mentoring or on-the-job training. Participants named the people they learn from in their job and rated the connection on a scale from 1 to 8 according to how active the learning is. Participants were encouraged to include persons from outside their organisation or research group. The scale of Helms et al is used, reproduced in Figure 3.1. At the most passive end, 1, is listening to a lecture or seminar, whereas the most active learning, rated 8, is guided experimentation. This rating is recorded as the strength of the connection, i.e. the weight of the edge between the two nodes of learner and teacher. It is thought that a person is more likely to retain knowledge from an active learning experience [31].

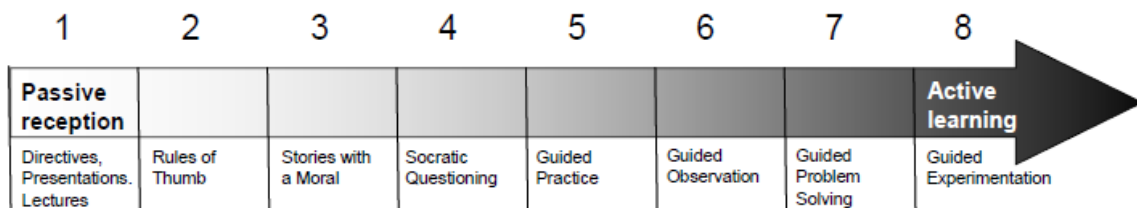

Figure 3.1: Passive to active scale of learning. Reproduced from [31].

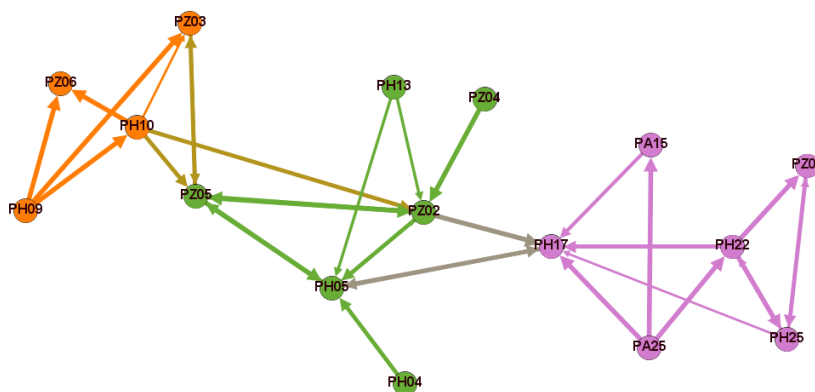

Figure.3.2: Example of a push network, from second pilot study. For simplicity, only participants are shown.

An example of a push network is shown in Figure.3.2. The nodes are scaled by a measurement of their Authority, as described below. The arrows point from the participants to those they have indicated are sources of knowledge.

A pull network is slightly different. Here the participants name the people they go to with questions, and the strength of the connection is determined by how frequently each named person is questioned, with 1 being yearly and 8 every few hours.

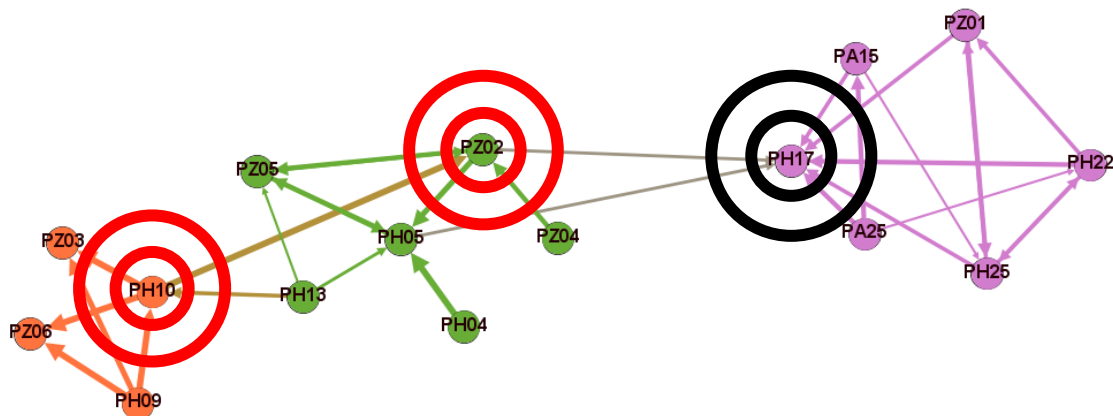

Figure 3.3: A network diagram with key people who link subgroups highlighted. Taken from the second pilot study (pull network). For simplicity, only participants are shown.

In the example shown in Figure 3.3 for the same group as the push network, the pull network is different. Each person is represented as a node in the network. The edges connecting them are weighted, according to the connection rating from 1 to 8 as listed above. The edges are directional, with the arrows going from the survey participant to those they name- i.e. from the questioner to those they ask, or from the learner to those they learn from.

With reference to Figure 3.3, the three key figures linking the teams within the group are immediately apparent. Person PH17 is the group manager, who also leads the pink team- but has no direct links to questionnaire participants in the orange team. Person PH10 is the link between the orange team and the green, and person PZ02 is the only participant to directly link all three teams. At the time this was presented to the group manager, person PZ02 had given notice to leave the company. The manager expressed great concern when shown this, as they were previously unaware of the key knowledge broker role played by PZ02. Persons denoted PZ rather than PH did not participate in the later study along with others at the Research Institute- and PZ02 did leave as planned.

### 3.2.5.1 Network Diagram construction

The network diagrams shown were constructed using Gephi [192]. The layouts were generated using the Force Atlas tool, which models each node as repelling all others, then adds an attractive force between connected nodes, proportional to the edge weight. There are many statistical measures which can be performed on such networks. Two methods initially developed for web search are compared here for utility in describing networks of people.

#### Authority and Hubs

While a simple visual inspection of a knowledge network is often sufficient to identify points of interest and of concern, it can also be useful to employ statistical tools. It is not possible to compare the organisations directly using metrics for network size or density, as in many cases the number of participants in a group is too small for this to be valid, or to be representative of their organisation as a whole. However, the Authority of each node in a network, from the data we have, can be a valuable statistic. Authority is calculated using an iterative algorithm (Hyperlink-Induced Topic Search, or HITS), based on a process originally designed to rank web pages returned when searching for a specific term using the hyperlinks which lead to them [195], [197]. The process is as follows:

- 1) Set all initial Hub values to 1
- 2) Update Authority. Each Authority value is the sum of Hub values of the nodes pointing to it.
- 3) Update Hub. Each Hub value is the sum of Authority values of the nodes it points to.
- 4) Normalise Hub and Authority values. Divide each Hub value by the square root of the sum of the squares of all Hub values in the network. Divide each Authority value by the square root of the sum of the squares of all Authority values in the network.
- 5) GOTO 2)

This iterative process results in converged Hub and Authority values for each node (person).

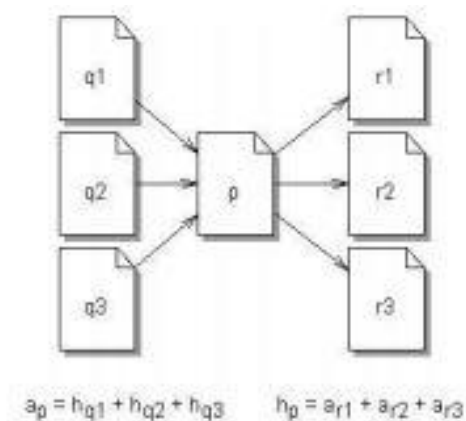

Figure 3.4: Illustration of calculation of Authority,  $a_p$ , and Hub,  $h_p$ , for page  $p$ , reproduced from [195]



A node which is linked to by a large number of highly ranked 'Hub' nodes has a high Authority measurement. Linking to a large number of high Authority nodes defines a highly ranked Hub- it indicates the value of the links from the node rather than the node's own authority.

In this context, a person of high Authority can be considered a good source of knowledge in the network, and a person of high Hub ranking learns from many people. It should be noted that this method does not account for edge weighting, only for number of nodes.

### PageRank

This method, famous as the basis of the Google search engine [194], is based on the concept that the value of a node is determined by the values of the nodes that link to it. A node with many links pointing to it may have a high rank, but a node with a single link from a very highly ranked node will also have a high rank.

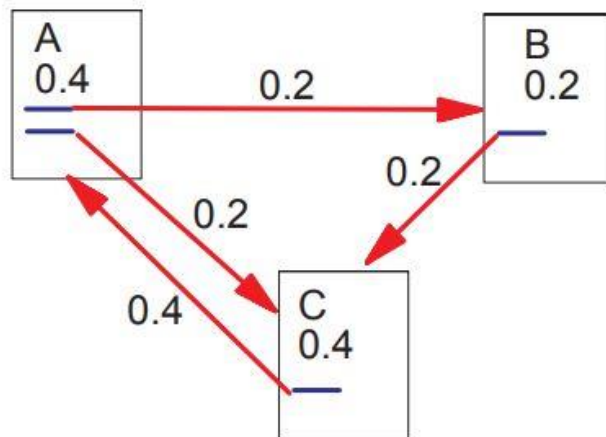

Figure 3.5: Illustration of a simplified PageRank calculation, reproduced from [194]

The algorithm ranks web pages based on incoming links to each page in an iterative process. Each page's rank is determined by the sum of the links pointing to it, and this rank is then split evenly between the links from that page to other pages, contributing to their ranks.

However, some pages do not have any onward links, or link only to other pages within a closed loop. This can lead to a Rank Sink, where a page has an incoming link from the wider web, but its only outgoing link follows a loop back to itself, as illustrated in Figure 3.6

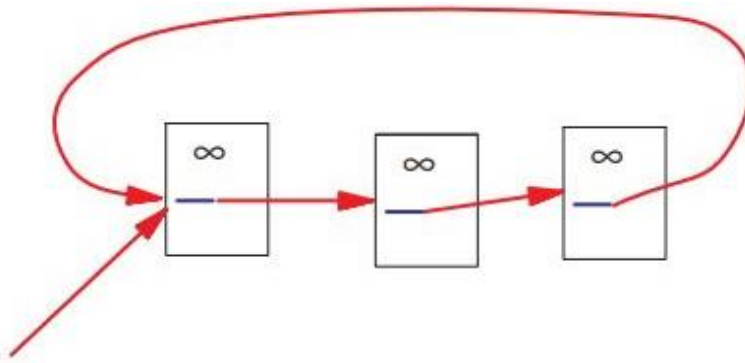

Figure 3.6: Illustration of a Rank Sink, reproduced from [194]

To allow for this, PageRank included a damping factor, usually 0.85, representing the probability of a person following a link on a page rather than randomly jumping to a non-linked page (i.e. probability 0.15 of jumping away), as in reality one would not follow such a loop indefinitely [194]. Unlike HITS, the Gephi implementation of PageRank can take account of the weights of the links [195]- so for these networks, the passive-active rating of the learning or frequency of questioning.

### 3.2.5.2 Limitations of this approach

The networks thus generated are not without flaws. The larger the proportion of the group who participate, the closer the result will be to reality. Where participation rates are low, the networks may not be representative of the companies.

Non-participants named by the participants are included, and in some cases key team members who were absent during the study can be identified this way, but of course the data does not include outgoing links from non-participants. In some cases participants have identified a source of knowledge by something other than a name- e.g. 'Team Leader' or 'Finance Department'. Without knowing who the Team Leader in question is, or whether two people have the same Team Leader, these are of limited value so are not included. Finally, it is important to note that while guidance is provided, subjectivity remains. Some people will name a large number of knowledge sources, others very few. Whether this is a representation of reality, or simply that some people are more likely to remember a large number of learning instances than others, cannot easily be determined.

In using the HITS and PageRank metrics, it is important to bear in mind that humans are not web pages. One might reasonably choose to link to a website based on the content, the reputation of the author or institution, or even ease of use. One might equally choose which colleague to question based on their knowledge, reputation or skill at explanation- but in a social situation, unrelated factors such as allegiance to a football team could be much more important than that. Some interesting cases will be highlighted.

### 3.3 Key Findings: Knowledge Networks

#### 3.3.1 Case Study: Authority measurements in Company 8

At Company 8, the majority of employees participated in the study. Company 8 has a dense, well linked network, which looks similar in pull and push (Figure 3.7). Sizing nodes by Authority a few key persons stand out. PN05, PN06 and PN10, highlighted in green, are senior figures at the company.

Comparing push and pull networks, we can see that person PN11 (highlighted in yellow) has high Authority in the pull network, but less in the push network. It may be that this person is better suited to answering questions than teaching- or that they are under-utilised in teaching others. Other high authority people go to PN11 with questions but do not formally learn from them.

Sizing by Hubs rather than Authority, we can see the people who, while not a key Authority themselves, are well placed to share knowledge within the company. For example, person PN03 has a relatively low Authority score in both networks but a large Hub score. This person may not be an expert themselves, but knows who to ask. Hub scores are more evenly spread throughout the participants, indicating that most employees have similarly good access to authoritative sources of knowledge. Non-participants, who only receive links, will always have a Hub score of zero.

This network is robust- if a single person were to leave, while the company might well miss them, it would not cause anyone else to be isolated, so would not disrupt the flow of communication- and hence knowledge- within the company. This also allows for good succession planning, ensuring that any person who is planning to leave transfers as much knowledge as is possible to others at the company before they go. However, many people formally learn (push network) from each expert. This can create bottlenecks [31] if the experts' time is limited.

##### 3.3.1.1 Comparing HITS and Pagerank

PageRank's damping factor for random jumping is useful in modelling web surfing but may be less so here- the networks are drawn directly from people listing who they learn from and go to with questions. Setting the damping factor to 1 removes this complication and did not make a noticeable difference to the network beyond making minimum size nodes slightly larger. The two algorithms give notably different results when Authority is compared with weighted PageRank (Figure 3.7). The weighted PageRank's inclusion of edge weight should give a more realistic result as it reflects the viscosity of knowledge transfer reported by the participants. It appears to under-rate non-participants, such as person NN01, highlighted in blue. The sum of the weights of the incoming links to NN01 in the pull network is 61 (data available in electronic appendix), which compares reasonably with 57 for PN04 or 55 or PN06 (PN05 has the highest with 107). NN01 appears a similar size to PN04 and PN06 in the Authority graph but is significantly smaller in the PageRank ratings.

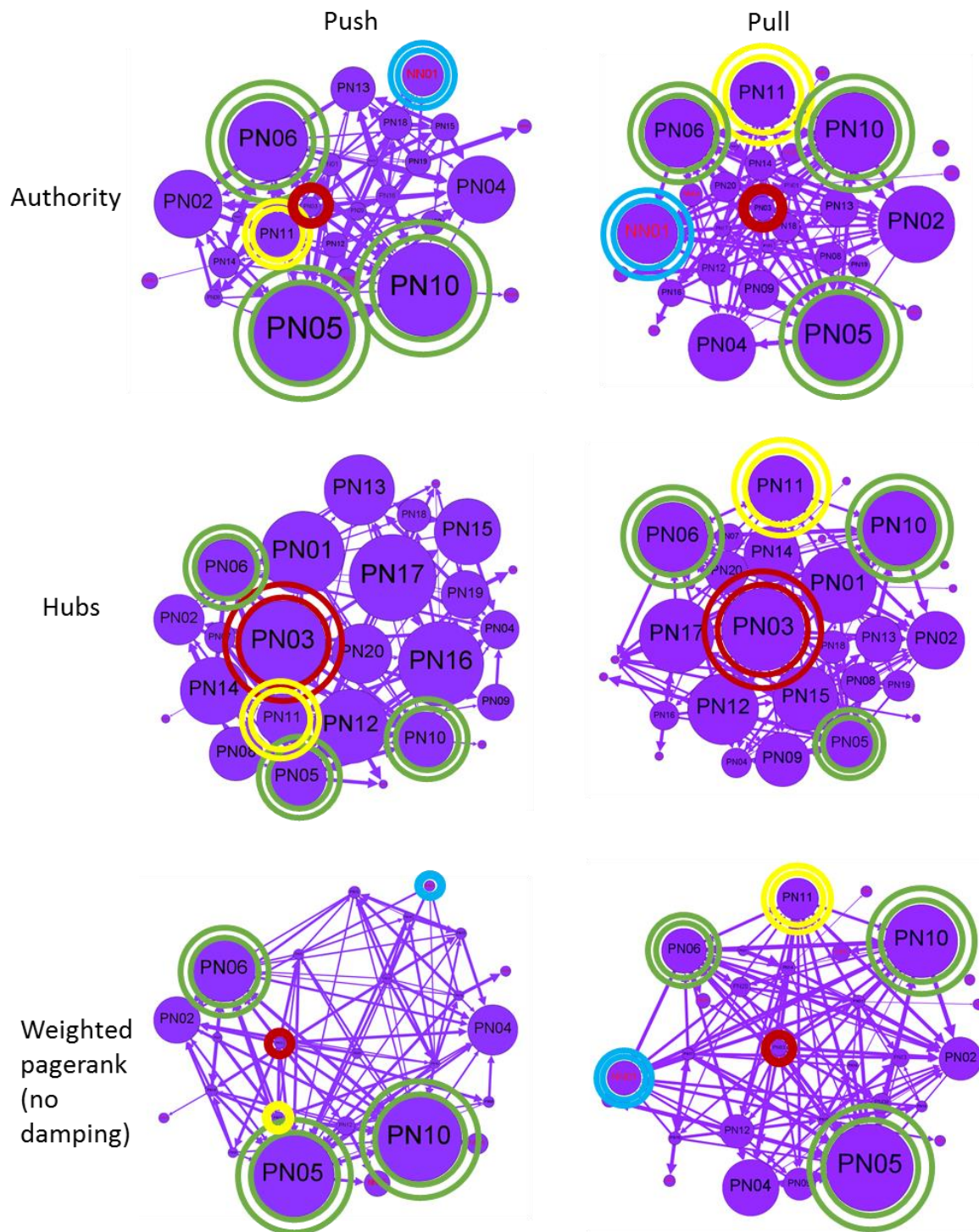

Figure 3.7: Push and pull networks for Company 8, with nodes sized by Authority, Hubs and Weighted PageRank (no damping). Nodes highlighted in green represent known senior figures at the company. Person PN03 is highlighted in red, person PN11 in yellow and person NN01 in blue. Non-participants labelled in red.

### 3.3.2 Links between participating organisations

Where the same person is named by more than one group, they form a link between the groups. A combined pull network is shown in Figure 3.8. Note that Company 8 looks different here as the graph is not centred on them. The large blue and green network at top left is a combination of the Research Institute (blue) and Academic group 1 (green), which are strongly interlinked, but of the companies, only Company 7 asks questions of Academic group 1. Academic group 2 (yellow) is strongly linked to Company 2 (orange), a spin-off of theirs, but no other company.

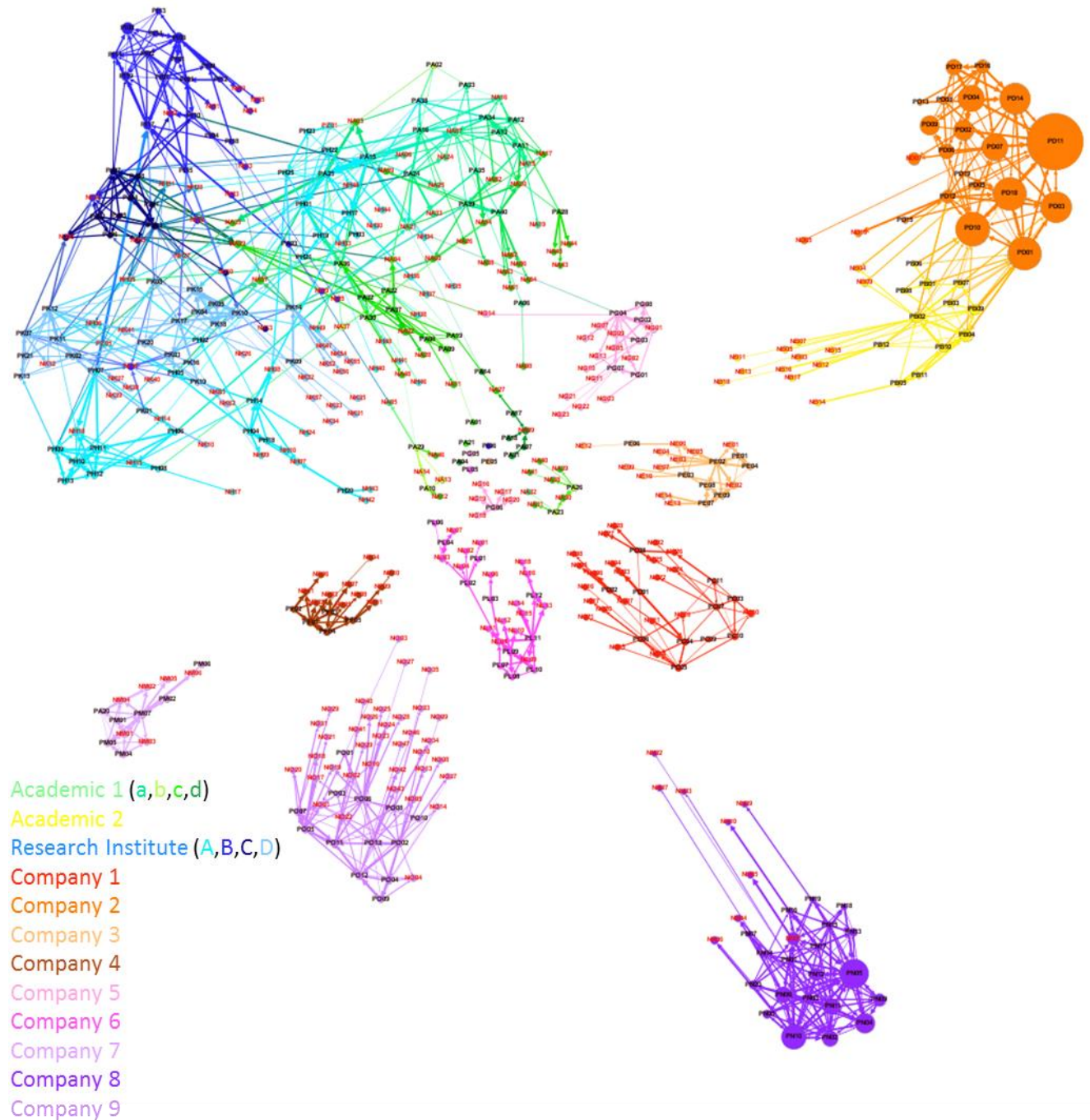
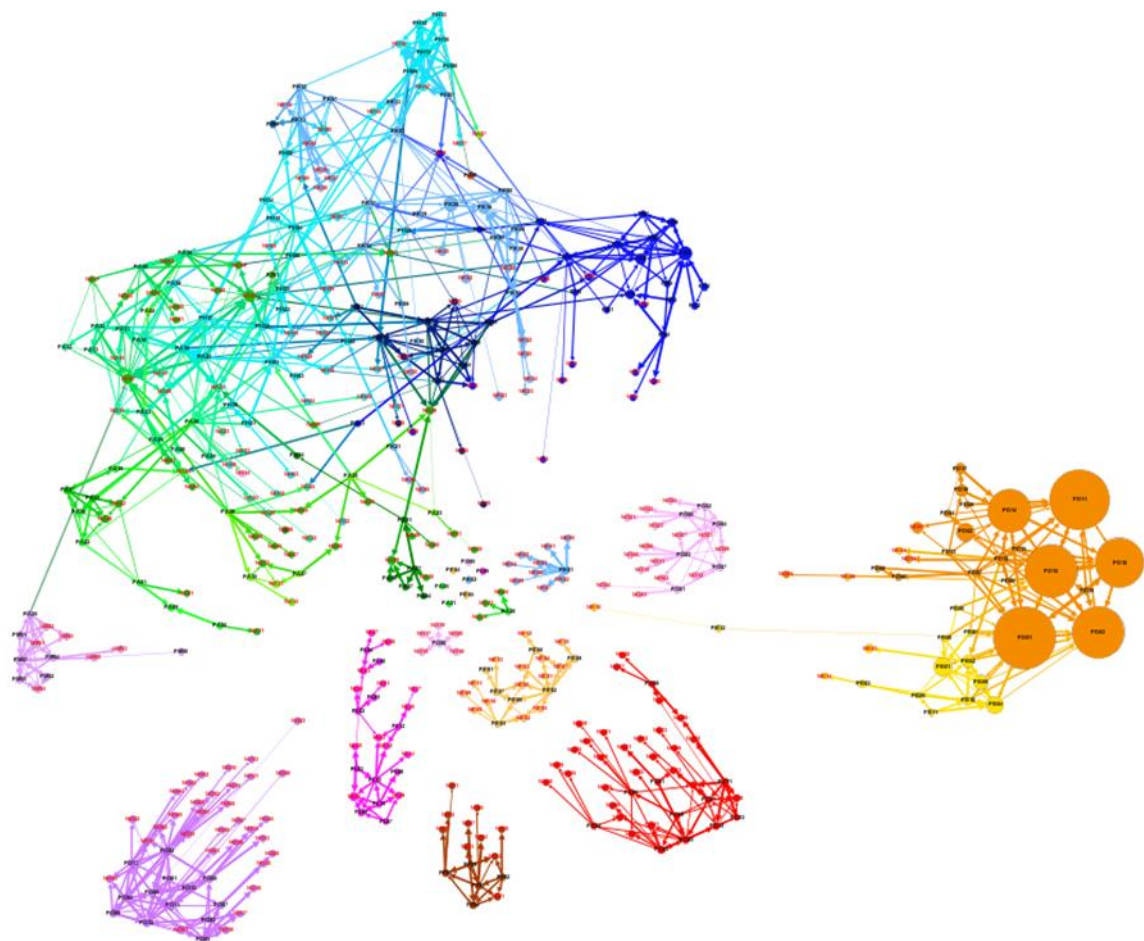

Figure 3.8: Pull network for all participants. Nodes sized by weighted PageRank with no damping.





- Academic 1 (a,b,c,d)
- Academic 2
- Research Institute (A,B,C,D)
- Company 1
- Company 2
- Company 3
- Company 4
- Company 5
- Company 6
- Company 7
- Company 8
- Company 9



Figure 3.9: Push network for all participants. Nodes sized by PageRank with no damping.

Figure 3.9 shows the combined push network. Here there is no link between Academic group 1 (green) and Company 5 (soft pink), but there is a link between Academic group 1 (green) and Company 7 (lilac), via an EngD student- who notably does not form a link in the pull network, so does not ask questions of their academic supervisor.

Perhaps disappointingly, individuals from the Research Institution and Academic Groups are not named as sources of knowledge by all participating Companies. The author could be considered a link between the two academic groups, but this is not shown as I did not participate in the surveys.

For both Figure 3.8 and Figure 3.9, the layout of the diagram is determined by the Gephi 'Force Atlas 2' algorithm [219]. This balances an attractive 'force' between connected nodes with a repulsive 'force' between all nodes and a central 'gravity' towards the centre of the diagram. Nodes are initially positioned in a random manner, then the 'forces' are applied, usually resulting in an equilibrium situation. Company 8 is no less connected to the research institution than company 1, as both have 0 connections to any external organisation- but company 1 appears internally more spread out than company 8 as company 8 has more, and stronger, internal connections between nodes.

### 3.3.2.1 Communities and knowledge transfer between organisations

Communities, also referred to as cliques, are groups of more densely connected nodes with sparser connections between them. There are a variety of methods for partitioning the network into communities, with the quality of the partitions measured by a value called modularity, which measures the density of links inside the groups compared to links between them. The algorithm used in Gephi [198] is designed to quickly find high modularity partitions in a network, with the resulting communities referred to as modularity classes.

Figure 3.10 shows an example, the pull network from the second pilot study. The three teams making up this research group are differentiated clearly.

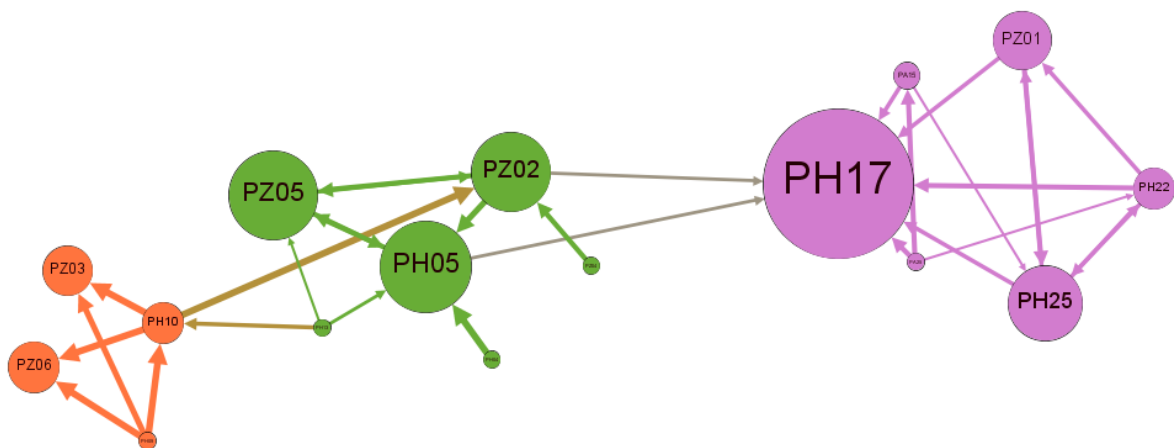

Figure 3.10: Pull network from the second pilot study coloured by modularity class, with nodes sized by PageRank with no damping. Only participants are shown.

### *Academic group 2 links to Company 2*

The Canadian companies are all signed up to a research network run by Academic Group 2- and were contacted through that network- but links are only seen with Company 2, which is an on-campus spinoff from that group.

When all organisations are analysed together, Academic group 2 and Company 2 are assigned to the same modularity class by the Gephi algorithm [198] indicating that they are so closely interlinked as to form one community. This can be seen in Figure 3.11 and Figure 3.12. Staff at Company 2 have notably higher weighted PageRank ratings than those at Academic group 2.

The strong links between Academic group 2 and its spin-off, Company 2, are considered sufficient for exchanging “deep smarts” [220]. The combined group forms a robust network but remains more clearly separated than the Research Institution-Academic Group 1 set in the UK. Most of the links between Academic Group 2 and Company 2 pass through a small number of people at Company 2, which might result in a severing of ties if these key people were to move on or retire unless efforts are made to avoid this.

### *Academic group 1 and Research Institution links to companies.*

A more complicated interlinking can be seen between Academic group 1 and the Research Institution in the UK. Indeed, it is difficult to see a boundary between the two organisations and the sub-groups which comprise them. From the networks coloured by modularity class, we can see that in many cases the detected cliques do not line up perfectly with membership of a particular team in the research organisation or the universities which make up the academic group. While links between University a and the Research Institution are very much to be expected, there are strong links with most of the universities. However, two people from this Academic Group are entirely separated from the others in the pull network

The UK companies were contacted through the Research Institution, Academic Group 1 and an external body, Composites UK. The Research Institution and Company 7 host EngD students who are members of Academic Group 1, some of whom provide links between these organisations. One person from Company 9 named the Research Institution n (but not a specific person) as a source of knowledge. Company 5 also has a link to Academic group 1- through a PhD graduate. Company 7 hosts an EngD student, who links to their academic supervisor on the push network only.

It is worth noting at this point that, were this exercise to be carried out regularly with a representative sample of composites organisations it could be used to investigate the success of programmes intended to increase links between academia and industry.



### *Teams within Research Institution and Academic Group 1*

The survey was carried out separately- though within a short time period- with each capability team within the research institution. For reasons of practicality, only capability teams- those with technical roles- were included. This includes researchers and operators in a variety of areas, and team leaders and managers. Teams often collaborate on projects. We can see that the C and B teams are quite well defined, but the A and D team members are more spread out through the research institution-academic 1 network.

When sorted by modularity class (cliques) along with the other organisations in the study individuals do not always line up with their teams. Cliques include people from both academic group 1 and the research institution, though these are different in the push and pull networks. Broadly, this demonstrates strong links between this academic group and the research institution, which contrasts markedly with the almost total lack of links to the UK companies in this study.

### *Lack of knowledge transfer links between composites SMEs and academia*

The combination of the Research Institution and Academic Group 1 forms a more integrated network than is often seen within single organisations distributed over multiple sites [191], [220]–[222]. One element of Academic Group 1 is located in the same city as the Research Institution, but others are not.

By contrast the almost total lack of links between this combined group and the other organisations suggest that no knowledge transfer is taking place between academia and these UK SMEs in the composites industry. A similar picture exists in Canada, where three of the four Canadian companies have no link to Academic group 2, the only exception being a spin-out based on campus. There are also no knowledge transfer links in either push or pull between the UK and Canadian academic groups, though staff from the two are known to communicate.

It should be noted that the companies invited to participate in this study were all recommended by members of staff at the two academic groups and the research institution- in most cases by persons whose job responsibilities specifically included connections to SMEs. It is therefore likely that these represent the SMEs with the closest links to the academic groups and research institution, making the lack of connections all the more notable.

In some studies knowledge networks of multiple organisations are constructed using proxies [199]–[202] such as lists of partners on a website. Had this been used here, the SMEs would have been considered connected to the institutions which recommended them, suggesting that proxy measures such as this may not be representative of knowledge transfer at the employee level.

As these employees are knowledge workers, if they do not learn from the link between companies it is questionable whether useful knowledge transfer occurs, though there may of course be other benefits to such links.

As discussed in the literature review, in other industries [203]–[206] many links can be found between academic/research institutions and SMEs, contrasting to the distinct lack shown here. These links were found by interviewing representatives of the companies, so may be more representative of reality than the proxy measures discussed above, though in most cases the interviewees were CEOs rather than employees. In an SME the CEO may be sufficiently aware of knowledge transfer at the employee level and may carry out other jobs themselves in addition to leading the company, which would be difficult in larger companies, but this cannot be stated with certainty.

McDermott et al [206] research involved talking to employees (enologists and agronomists) alongside executives so may be more reasonably compared to the results found here for composites SMEs, though the knowledge transfer links are shown at the organisation level only, not the individual. Again, links between companies and “government support institutions” with a research remit are seen, and the region which had invested in a large number of such support institutions showed significantly more connections than the region which had not.

The method used in this thesis is different, as each node is not an organisation but a person, with the intention of illustrating knowledge transfer at the individual level. Participants were specifically asked to consider people outside their own organisations as well as within when identifying those they learn from. Asking knowledge workers who carry out engineering tasks on a day to day basis to identify their sources of knowledge gives an indication of whether or not purported links between organisations facilitates knowledge transfer at the team and personal level.

This method is commonly used within individual organisations with multiple sites or working groups [191], [220]–[222]. In these cases, push network links with a viscosity of less than 5 were considered inadequate for “deep smarts” knowledge transfer [220] and having only three or four knowledge transfer links between geographically separate groups was considered problematic [191]. A complete lack of links between the engineers at an academic group or research institution and those at an SME which is recommended by persons whose jobs involve knowledge transfer to such companies is therefore of concern. For avoidance of doubt: this work should not be used to infer anything about connections between the academic groups, research institution and larger companies in the composites industry. Some larger companies have staff permanently on-site at the research institution- this is not the case for the SMEs.

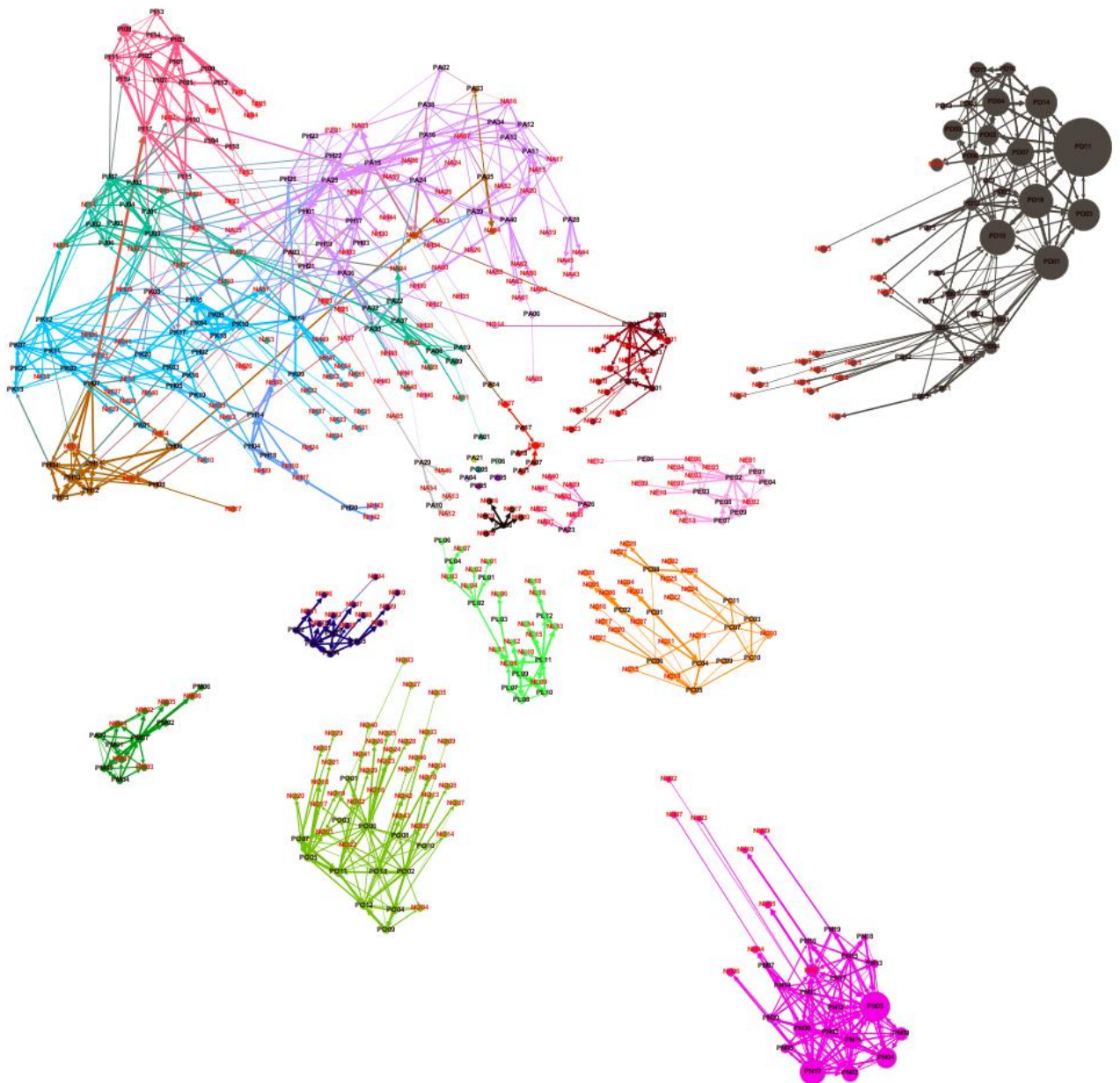

Figure 3.11: Pull network of all organisations by modularity class (clique). Note that academic group 2 and company 2 register as a single clique and that the groups within the research institution and academic group 1 do not line up with the capability teams in the RI or the universities within the academic group, with academics combined with RI staff in some cliques. Nodes sized by PageRank with no damping.

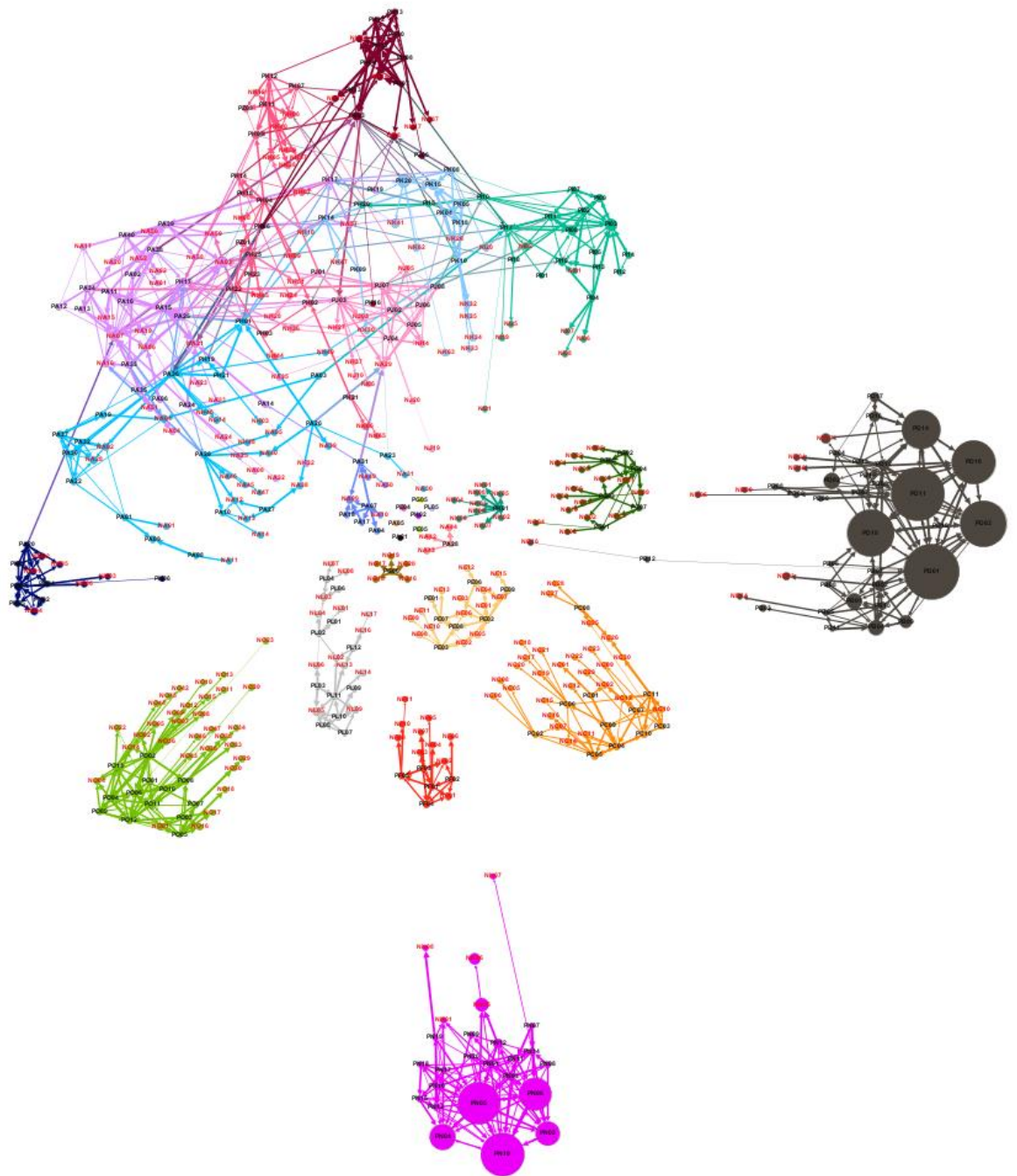

Figure 3.12: Push network of all organisations by modularity class (clique). Again academic group 2 and company 2 register as a single clique. Here the groups within the research institution and academic group 1 combine differently to the pull network. Nodes sized by PageRank with no damping.

### 3.3.3 Case study: Before And After- Pilot study team

The pilot study results show networks with a clear split into teams, very dependent on a few key linking people- one of whom, PZ02, had just handed in their notice.

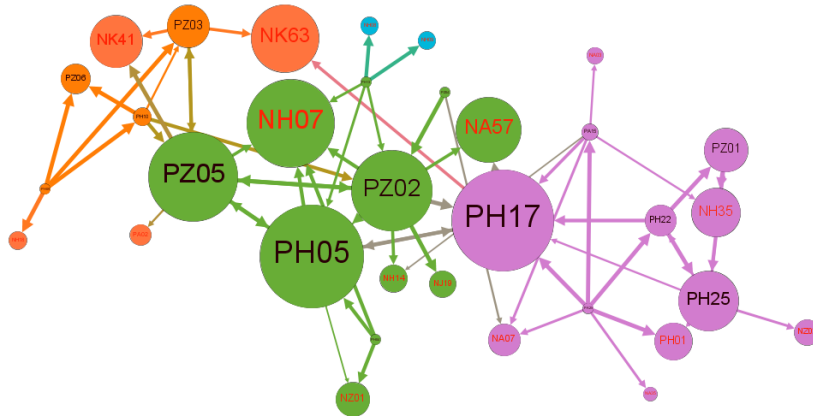

Figure 3.13: Pilot group push network, coloured by modularity class and node size by pagerank with no damping. Non-participants labelled in red.

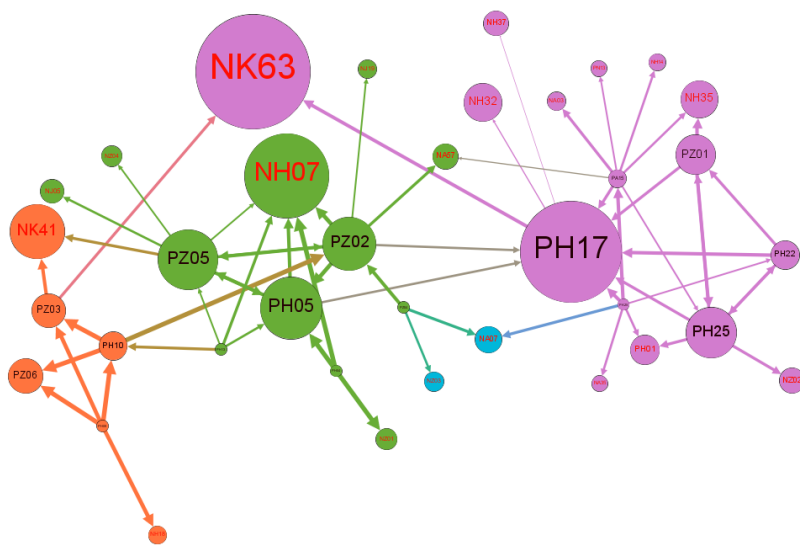

Figure 3.14: Pilot group pull network, coloured by modularity class and node size by pagerank with no damping. Non-participants labelled in red.

The group manager- PH17- was extremely concerned by this situation, and by the lack of direct link between himself and the orange team. Relying on a small number of people means that if any one person leaves, the rest of their team could be isolated. This also illustrates the importance of succession planning- if PZ02 is leaving, it is important not only that as much of their knowledge is retained as possible- through codifying in documents and through teaching others- but also that the link they form is not broken.

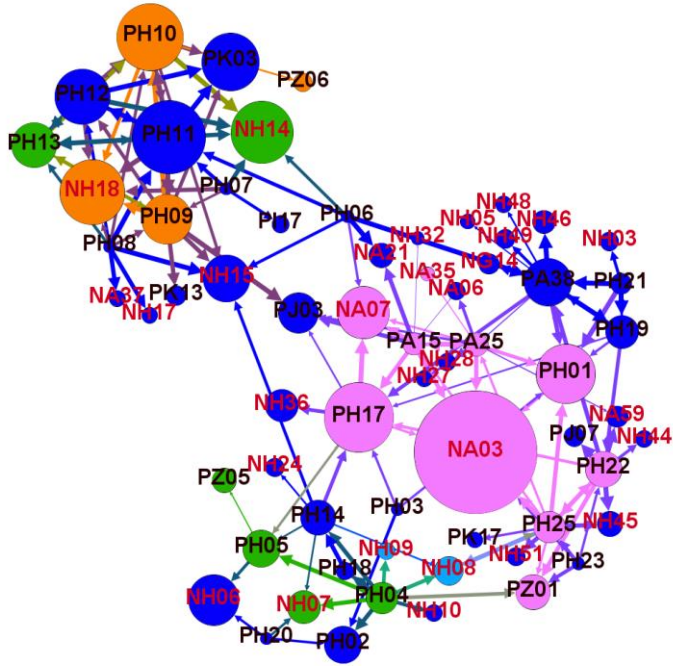

Figure 3.15: Same team during final study, push network. Coloured by modularity class from the pilot study, with those who were not in the pilot study in blue. Nodes sized by weighted pagerank with no damping. Non-participants are labelled in red.

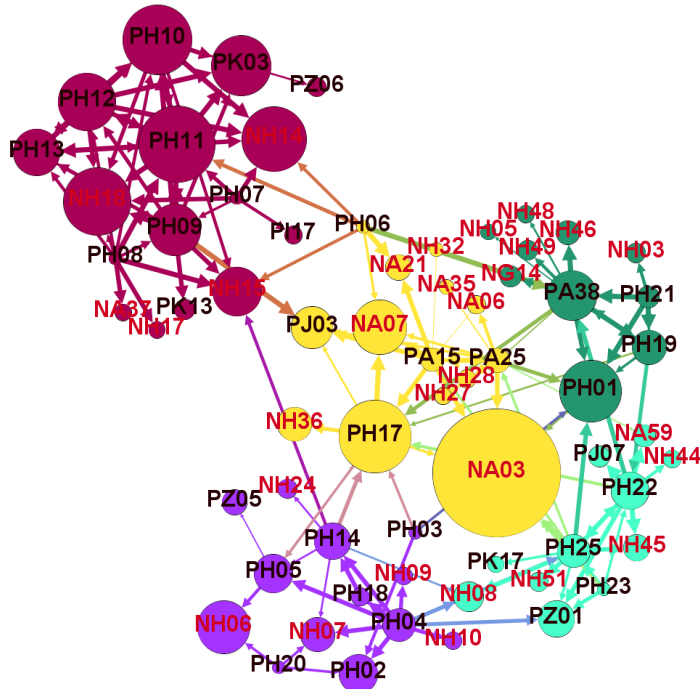

Figure 3.16: Same team during the final study, push network. Coloured by modularity class from this round. Nodes sized by weighted pagerank with no damping. Non-participants are labelled in red.



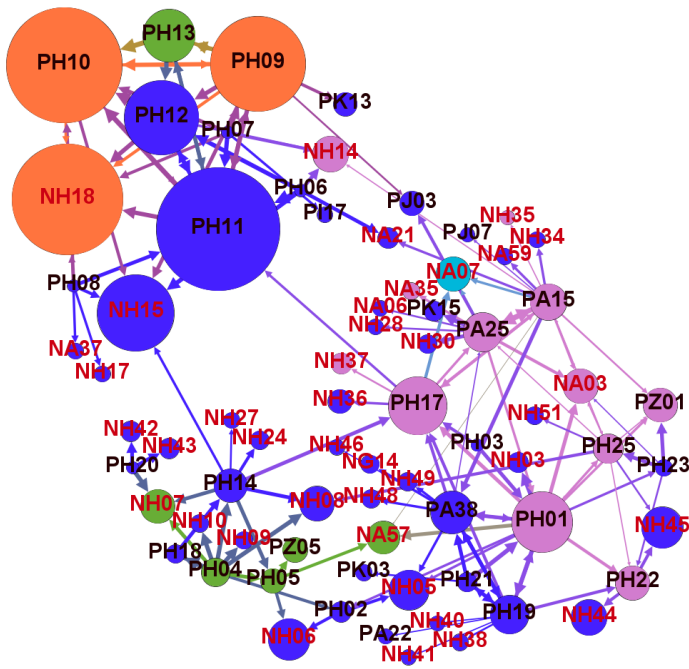

Figure 3.17: Same team during final study, pull network. Coloured by modularity class from the pilot study, with those who were not in the pilot study in blue. Nodes sized by weighted pagerank with no damping. Non-participants are labelled in red.

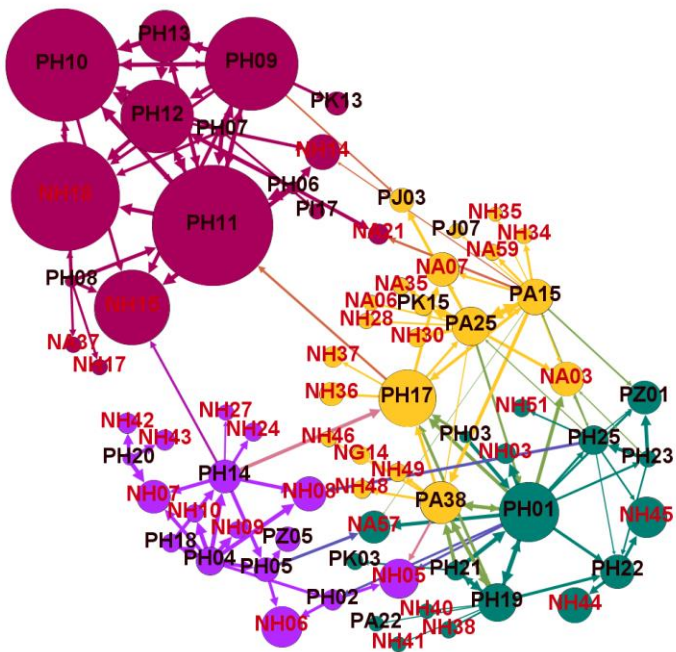

Figure 3.18: Same team during the final study, pull network. Coloured by modularity class from this round. Nodes sized by weighted pagerank with no damping. Non-participants are labelled in red.

In the final study at the research institution, this group is barely recognisable as the same as the pilot study. Not only are there more members- no surprise in a growing organisation- but the networks are now more robust. Comparing the modularity classes from the pilot study with the final study, the original teams have grown and in some cases split, and individuals have moved. Most importantly though, there are now multiple links both between and within each team.

While some individuals are still clearly important, there is no single individual who, if removed, would split the network. Individual development can also be seen- persons PH09 and PH10 in particular are now ranked far more highly, indicating that they are now transferring knowledge well. New person PH11 is central to the red team, whose members are highly rated in the pull network. The red team has only two links to the rest of the group in the push network (teaching), through a non-participant who teaches many people (a possible bottleneck) and participant PH06, who learns from many. The other teams are very closely interlinked in both networks. This result is comparable to that achieved in an expert consulting group by Cross et al [191], where a group which had unintentionally coalesced into two distinct teams discussed their network diagram and made an effort to become more integrated, resulting in a more robust structure nine months later.

This group has also developed stronger links to the Academic 1 organisation, whose members are represented by -A--, with person NA03 in particular providing a lot of teaching, not only to the EngD students (PA— as they are also Academic 1 members) but also to other group members.

### 3.4 Competence Matrices

A competence matrix, also known as a skills matrix, is a common tool for rating employee's abilities. Participants rate themselves from 1 (novice) to 5 (world leading expert) in areas that are important for their organisation. The subject areas are chosen by senior staff in the team, so these are not common across the different groups.

In this study, the method was adjusted slightly, by splitting theory and practical. This is to allow for the reality that a person may rate very highly in one but not in the other- for example, a professor may know all there is to know about the theory but have very little time to spend hands-on.

Conversely, the best person to create new equipment or fix what is there may not have studied all the detailed science describing the chemical reactions which take place in the process the equipment is for. Guidance on the levels was given as follows:

It is split into **theory** and **practical**, to allow for the possibility that some of the best practical experimenters may not have studied the theory in depth, whereas a leading Professor would



certainly be a level 5 in theory but might not be up to date with the latest practical tools and techniques.

For simulation, the split is as follows:

**Theory**- background understanding, mathematics and theory of techniques e.g. finite element analysis, fluid dynamics. **Practical**- getting useful output from commercial program or writing your own code

Level	
0: Complete beginner	No experience or knowledge of this at all.
1: Novice	I have heard of this but only just started working on it.
2: Capable	Solid understanding of the basics/I do the work reliably and confidently
3: Advanced	Detailed understanding/practical work on non-standard setups
4: Expert	Can answer almost any question/can make new methods, tools or experiments
5: World Class	World leading expert. Wrote the book/designed and built the machine.

Table 3.1: Self rating levels in questionnaire

Addition of colour coding allows a simple, visual, instant form of gap analysis- seeing straight away if there is an area where they do not have the expertise they need. It also shows clearly who rates themselves most highly in different areas.

Fibre-Bragg sensors	Theory	0	2	1	3	1
	Practical	0	1	2	2	1
Infrared cameras	Theory	3	2	2	1	3
	Practical	5	2	2	1	3
Direct tool heating	Theory	3	2	3	2	1
	Practical	4	1	3	1	1
IR lamp heating	Theory	5	2	2	2	2
	Practical	5	2	2	1	2
Flash lamp heating	Theory	2	2	2	3	1
	Practical	1	3	2	2	1
Autoclave cure	Theory	3	2	3	3	3
	Practical	3	1	3	1	2
Microwave cure	Theory	0	2	1	2	1
	Practical	0	2	1	1	1
NDE	Theory	4	2	1	2	3
	Practical	2	2	1	1	1
Adhesive application	Theory	3	3	4	4	1
	Practical	4	3	4	3	1
Fixturing	Theory	3	1	4	2	1
	Practical	5	1	4	1	1
Debulking	Theory	5	2	5	4	2
	Practical	5	2	5	2	2

Figure 3.19: extract from a competence matrix using the theory/practical split. Each column represents a person. Staff rate themselves from 0 to 5, with 5 being a world class expert.

Adding the results from the knowledge network analysis as a point of comparison can help to counter this- if someone is modest but rated very highly as a source of knowledge by their colleagues, this can easily be seen. Conversely, someone who rates themselves very highly may be over-optimistic about their own level- or may not be well suited to communication with others. Personality is important- a person may be highly expert but rated lower by their colleagues if they are not easy to approach or someone else is a better communicator.

It is commonly held [29] that a person learning a new skill proceeds from novice, through competent, to expert, to being able to teach others. This neglects that teaching is itself a skill, and personality can be as important as ability when a person chooses to whom they should pose their questions.

Fibre-Bragg sensors	Theory	0	2	1	3	1
	Practical	0	1	2	2	1
Infrared cameras	Theory	3	2	2	1	3
	Practical	5	2	2	1	3
Direct tool heating	Theory	3	2	3	2	1
	Practical	4	1	3	1	1
IR lamp heating	Theory	5	2	2	2	2
	Practical	5	2	2	1	2
Flash lamp heating	Theory	2	2	2	3	1
	Practical	1	3	2	2	1
Autoclave cure	Theory	3	2	3	3	3
	Practical	3	1	3	1	2
Microwave cure	Theory	0	2	1	2	1
	Practical	0	2	1	1	1
NDE	Theory	4	2	1	2	3
	Practical	2	2	1	1	1
Adhesive application	Theory	3	3	4	4	1
	Practical	4	3	4	3	1
Fixturing	Theory	3	1	4	2	1
	Practical	5	1	4	1	1
Debulking	Theory	5	2	5	4	2
	Practical	5	2	5	2	2
KNA totals	Push	13	13	34	40	8
	Pull	10	8	25	35	6
KNA connections	Push	2	2	5	6	1
	Pull	2	2	4	7	1

Figure 3.20: The same extract with the addition of results from the knowledge network analysis, showing both the number (yellow) and sum of ratings (red) of connections from others in the team.

For each participant, the self-rated competence matrix is compared to statistics from the knowledge networks. Simple number of connections and totals of connection weights are shown, though Authority and Hub measurements might also be useful if the number of participants is large proportion of the total at the organisation. This novel combination of Knowledge Network Analysis with a Competence Matrix can be useful, as in the example below.

### 3.4.1 Case Study: Working Cultures at Company 6

It was noted in the interview with Company 6 representatives that two teams within their workforce- Laminators and Fitters- appear to have very different working cultures. The Knowledge Networks can be used to investigate whether this affects their knowledge transfer. Members of both teams, along with some more senior staff, participated in the survey. They did not identify which team they belong to; however, we can reasonably estimate this from the competence matrix.

			PL01	PL02	PL03	PL04	PL05	PL06	PL07	PL08	PL09	PL10	PL11	PL12	
<b>Laminating</b>	Bagging a Component	Theory	3	3	1	3	4	4	4				1	1	2
		Practical	1	2	1	4	4	4	4				0	0	0
	Basic Laying Up Techni	Theory	3	3	1	3	5	4	4				1	1	3
		Practical	2	2	1	3	5	4	4				0	0	0
	Filling Out Areas With	Theory	3	3	1	3	5	4	4				1	1	3
		Practical	2	2	1	3	5	4	4				0	0	0
	Laminating a 1-8-1 Cart	Theory	3	3	1	4	5	4	4				1	0	2
		Practical	2	2	1	4	5	4	4				0	0	0
	Sealing and Releasing	Theory	3	3	2	3	4	4	4				1	1	2
		Practical	2	2	2	4	4	4	4				0	0	0
	Sealing and Releasing	Theory	3	3	2	3	4	4	4				1	1	2
		Practical	2	2	2	4	4	4	4				0	0	0
	De-Bulking	Theory	3	3	2	4	5	4	4				0	1	3
		Practical	2	2	2	4	5	4	4				0	0	0
	Kit Cutter	Theory	3	2	0	4	1	4	4				0	1	0
		Practical	0	1	0	4	1	3	4				0	0	0
	Drop/Leak Testing	Theory	3	3	2	3	5	4	4				0	1	0
		Practical	2	2	2	4	5	4	4				0	0	0
	Peel-Ply	Theory	3	3	1	2	4	4	4				0	1	2
		Practical	2	2	1	3	4	4	4				0	0	0
Using Plymatch	Theory	1	1	1	2	4	0	0				0	2	0	
	Practical	0	1	1	3	4	0	0				0	2	0	
Wrapping Inserts	Theory	3	3	0	2	5	4	4				0	0	0	
	Practical	2	2	0	3	5	4	4				0	0	0	
<b>Lam. Fit</b>	Visual Quality Correct	Theory	3	3		2	5				4	3	3	3	
		Practical	1	3		2	5	4			4	3	3	2	
<b>Stores</b>	Storing Materials Used	Theory	3	3	1	2	3	4				1	0	0	
		Practical	1	3	1	2	3	4				0	0	0	
<b>Stores</b>	Storage Requirements	Theory	3	3	2	2	3	4				1	0	0	
		Practical	1	3	2	2	3	4				0	0	0	
<b>Repairs</b>	Machine Maintenance	Theory	2	3	0	1	4	2					0	0	0
		Practical	1	1	0	2	4	2					0	0	0
<b>All</b>	Approvals document	Theory	3	4	2	2	3	4			3	2	3	2	
		Practical	2	4	2	2	3	4	4			3	2	3	0
<b>Fitting</b>	Demoulding a Compon	Theory	3	3	3	2	3	4	2	4	4	4	4	4	3
		Practical	2	2	3	3	3	4	4	3	4	4	4	4	3
	Pattern Work	Theory	3	3	2	1	2	0	2	2	2	3	2	3	2
		Practical	1	2	2	1	2	0	2	2	2	3	2	3	1
	Blocking-Up	Theory	3	3	3	1	2	2	3	3	4	4	4	4	3
		Practical	2	2	3	1	2	2	3	3	4	4	4	4	3
	Filling Cavities Using A	Theory	2	3	2	1	2	1	3	4	3	4	4	4	3
		Practical	1	2	2	1	2	1	3	4	3	4	4	4	3
	Use of Machinery in Fi	Theory	3	2	2	3	3	2	2	4	4	4	2		3
		Practical	2	2	2	3	3	2	2	4	4	4	2		2
	Bonding	Theory	3	2	3	2	3	0	3	4	4	4	4	4	3
		Practical	2	2	3	2	3	0	3	4	4	4	4	4	2
	Drilling	Theory	3	3	3	3	3	2	3	4	4	4	4	4	2
		Practical	2	2	3	3	3	2	3	4	4	4	4	4	2
	Melt-Out	Theory	3	2	4	1	2	0	2	2	3	3	4	4	2
		Practical	2	2	4	1	2	0	3	2	3	3	4	4	2
	Trimming Components	Theory	3	3	3	1	3	0	3	4	4	4	4	4	3
		Practical	2	3	3	2	3	0	3	4	4	4	4	4	3
	Wet LayUp Repair	Theory	3	3	1	0	3	2	2	4	3	2	4	4	3
		Practical	1	2	1	0	3	2	2	4	3	2	4	4	2
Polishing	Theory	3	3	3	2	4	2	3	4	3	3	4	4	2	
	Practical	2	3	3	2	4	2	3	4	3	3	4	4	2	
Machine Maintenance	Theory	3	2	1	1	4	0	2	1	3	2	1	1	1	
	Practical	1	1	1	2	4	0	2	1	3	2	0	1	1	
Mould Surface Work	Theory	3	3	2	1	4	2	2	3	4	3	4	4	2	
	Practical	1	2	2	1	4	2	2	3	4	3	4	4	2	
<b>Engineering</b>	Detecting and Prevent	Theory	3	3	1	1	4	2				4	4	4	2
		Practical	2	3	1	0	4	2				4	4	4	1
<b>Engineering</b>	Non-Conformance Rep	Theory	3	3	0	0	2	0				2	2	2	2
		Practical	3	3	0	0	2	0				2	2	2	2
<b>Quality</b>	Route Card Completion	Theory	3	4	2	0	4	4				3	0	2	2
		Practical	3	4	2	0	4	4				3	0	2	2
<b>Quality</b>	Stamp Control	Theory	3	3	0	1	4	2				2	4	2	2
		Practical	2	3	0	1	4	2				2	4	1	1
<b>Quality</b>	Split Batch Control for	Theory	3	2	0	0	3	0				2	0	0	0
		Practical	2	2	0	0	3	0				2	0	0	0
<b>KNA totals</b>		Push	7	0	0	0	0	0	0	20	8	0	15	0	
<b>KNA connections</b>		Pull	5	0	0	0	0	0	0	23	4	0	6	7	
		Push	1	0	0	0	0	0	0	3	1	0	2	0	
		Pull	1	0	0	0	0	0	0	4	1	0	1	1	

Figure 3.21: The anonymised Competence Matrix for Company 6.

The value of the split between theoretical and practical knowledge can be seen from person PL01. This person consistently rates themselves higher at theory than practical work.

One can also see the split between laminators and fitters. Laminators consider themselves to have some competence in Fitting skills, but Fitters seem more specialised, with few competencies outside the Fitting skills listed for them.

With the addition of data from the Knowledge Networks - the number and total value of connections to each person- showing whether their colleagues consider them sources of knowledge- we can also see key figures emerging. Many of the fitting team rate their skills similarly, but person PL08 is the most popular source of knowledge in both push and pull terms. Conversely, person PL05, a laminator, considers themselves a world leading expert in a number of areas, yet none of their colleagues state that they learn from this person or go to them with questions

For a clearer illustration of the knowledge flows within the company we can use the network diagrams. Colouring nodes according to self-rating of key skills shows the two groups.

The pull network, showing who asks questions of whom, gives a better indicator of workplace culture than the push network of formal learning, as this may be imposed from above. In this instance the two were very similar, but only the pull network is shown for reasons of space. As not all employees participated- the highest ranked people are non-participants- this cannot be considered a full picture, but the contrast between laminators and fitters is nevertheless notable.

Those who rate themselves highly for a fitting skill are displayed as well connected nodes, near the top of the diagram, whereas those who rate themselves highly for a laminating skill are displayed as small and poorly- or non- connected nodes. This indicates that the fitting team ask questions of their expert colleagues far more than the laminating team. We can reasonably surmise that the fitters have a more robust, interlinked network than the laminators, some of whom seem isolated. . Those who rate their own expertise highly for laminating skills- persons PL04, PL05 and PL06- have no connections at all, so are unlikely to be passing their knowledge on to their less expert colleagues. Person PL01 transfers knowledge at high viscosity to person PL02, but PL02 self-rates their expertise higher than PL01 in many areas, suggesting that either the former is overconfident or the latter is being modest.

The links between the fitters allow them to learn as a team [179]. However, they are only linked to the laminators via person NL05, a member of the management team who did not participate in the study. Knowledge held by the fitting team and by the laminators may therefore remain siloed, as unless the manager in question makes a dedicated effort to encourage communication between the two groups they will have difficulty learning from each other.

The two areas of work are connected, as they manufacture the same part. For example, the layout process used by the laminators may affect the options available to the fitters [26]. If knowledge were shared, the two teams- and the wider organisation- could learn from each other and improve their manufacturing processes and possibly their products. Sadly, learning horizons [179] restricting the sharing of lessons between teams- or even between individuals- make it difficult for any individual to see the big picture.

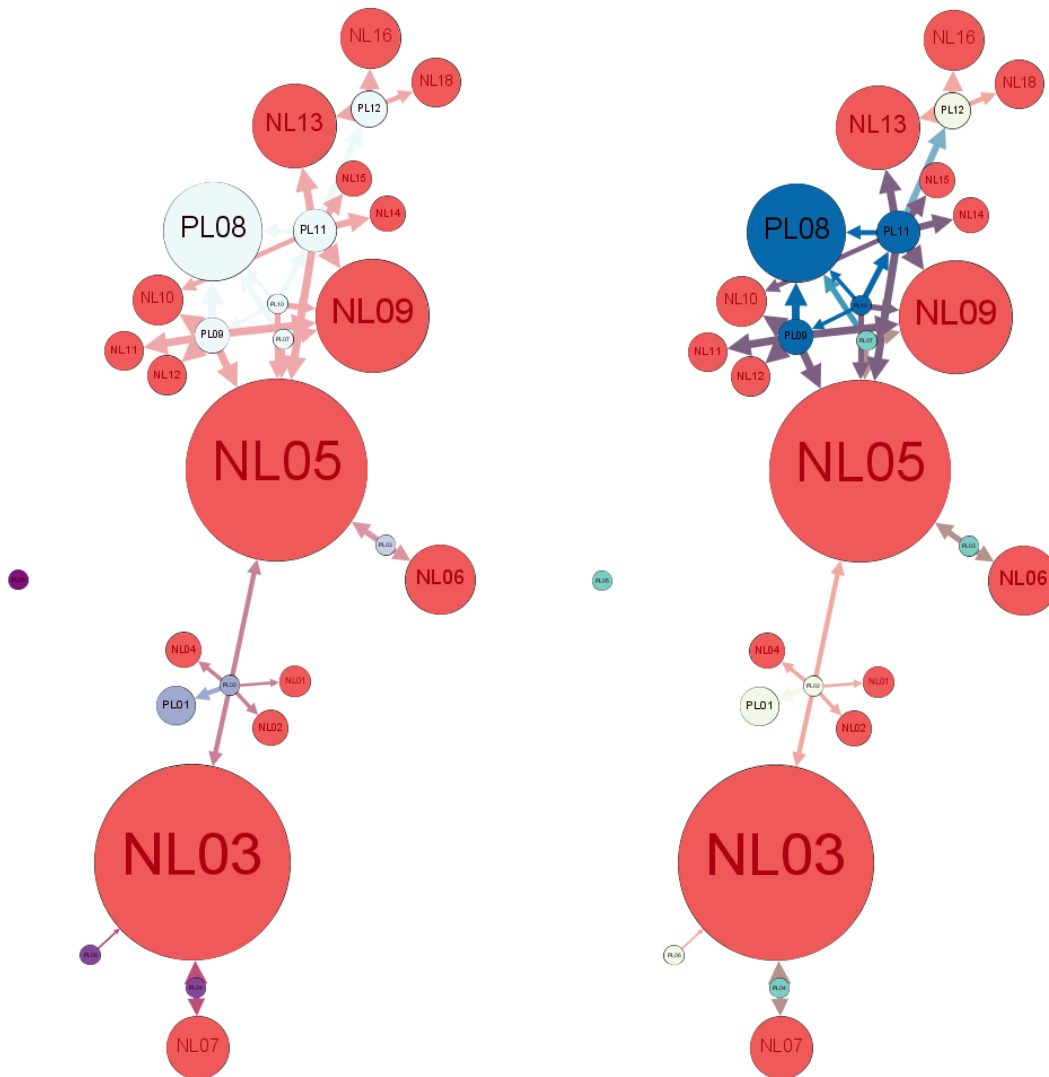

Figure 3.22 (left): Company 6 pull network coloured by self-rated competence at a key Laminating skill (laminating a 1-8-1 carbon mould, practical component). Darker purple is higher rated, white is zero. Non-participants are in red. Nodes sized by weighted PageRank with no damping.

Figure 3.23 (right): Company 6 pull network coloured by self-rated competence at a key Fitting skill (drilling, practical component). Darker blue is higher rated, cream is lower rated. Non-participants are in red. Nodes sized by weighted PageRank with no damping.

### 3.5 Aggregate results of opinion-based questions

Results from the anonymous, opinion-based questions from all 230 participants have been collated and are available in the electronic appendix.

#### 3.5.1 Organisation categories

This study focuses on comparing the different types of organisation, split as follows:

Academic: Academic 1 and Academic 2, a total of 53 participants.

RI: The four capability groups which comprise the Research Institution, 73 participants.

SME: Company 2, Company 3, Company 4, Company 6 and Company 8 are SMEs. Company 5 and Company 7 are owned by holding companies but operate mostly independently, so are also included in this category. 80 participants.

Large: Company 1 is larger than an SME, Company 9 is a multinational organisation, of which only the advanced composites group at one location participated. 24 participants.

Grouping the organisations in this manner makes it a little less likely that the results will be overwhelmingly influenced by the working culture of a particular company or university, with the exception of the research organisation- which, sitting between academia and industry, must be categorised separately. It should be noted that the RI's four capability teams have some different practices, but exist within the same building and overall structure. Again with the exception of the Research Institution (UK only), all categories contain organisations from both the UK and Canada.

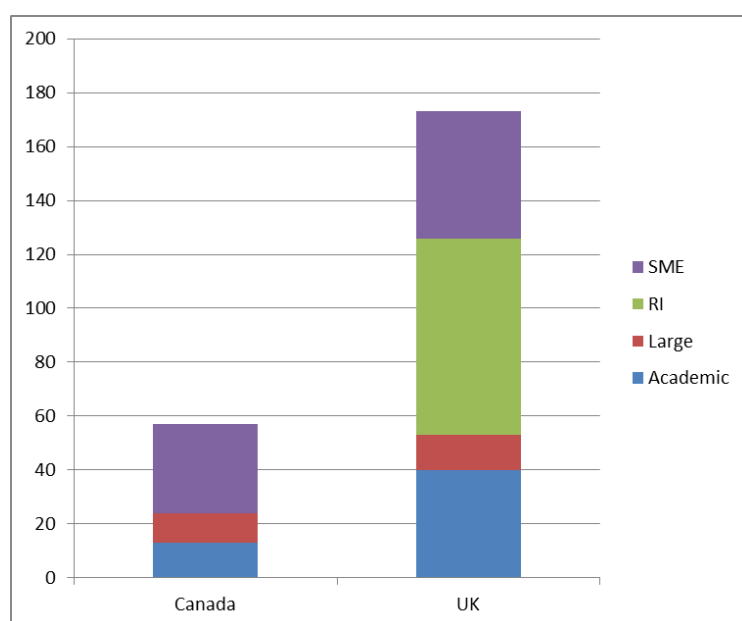

Figure 3.24: Number of participants in each category from Canada and the UK.

Approximately 75% of participants were based in the UK, with 25% in Canada (British Columbia).

### 3.5.2 Participant demographics

Participants were asked to state their age (to the nearest decade) and job type. This question was optional and some declined. Demographics differ by organisation type as shown.

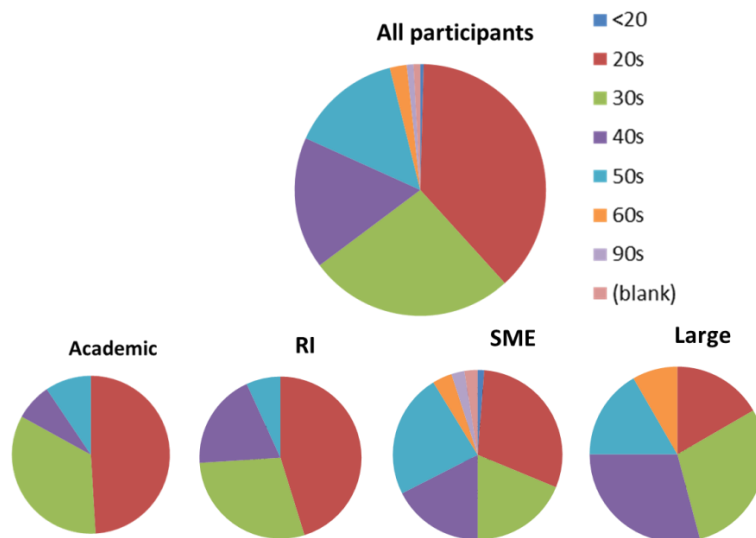

Figure 3.25: Participant ages by organisation type

The number of participants aged below 30 decreases from left to right. There are many academics aged over 60, but none chose to participate in this study. SMEs are willing to employ a small number of people aged significantly above the usual retirement age. Conversations with staff at these companies suggest that these very experienced persons are considered extremely valuable both to the company and to their colleagues.

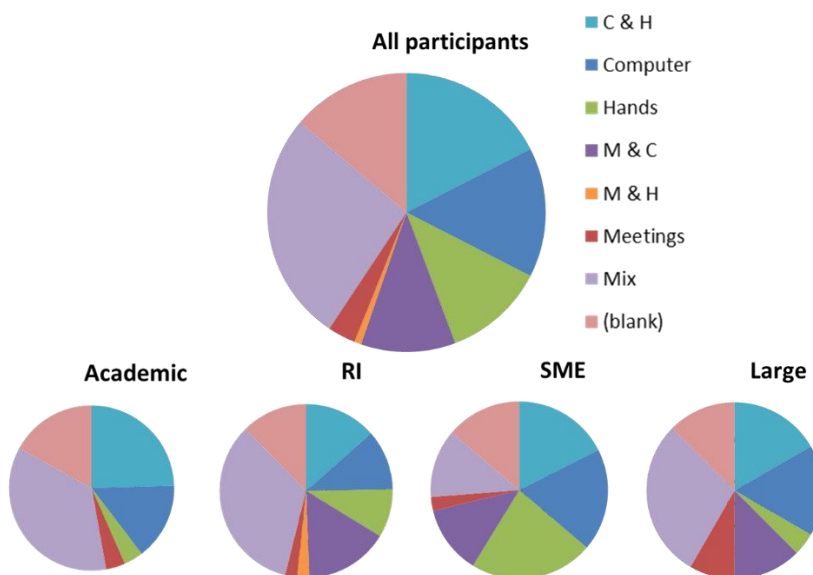

Figure 3.26: Participant job types by organisation type. Job types were selected on a Venn diagram showing Computer, Hands-on, Meetings and intersections between each and all three.

### 3.5.3 Current State of Knowledge Transfer

#### 3.5.3.1 Opinions on knowledge management in the organisations

Participants were asked to rate their agreement, from 1 (disagree) to 5 (agree), with four statements describing knowledge transfer related issues. The results, where darker shade of colour is a larger proportion of people, are shown below. Results are normalised by the number of people in each organisation type and presented as percentages, rounded to 2 significant figures.

	Disagree					Agree
	1	2	3	4	5	
<b>I know where to go when I need help</b>						
Academic	1.9%	1.9%	15%	45%	30%	
RI	1.4%	8.2%	32%	37%	21%	
SME	0%	2.5%	16%	38%	43%	
Large	0%	4.2%	13%	58%	25%	
<b>All participants</b>	<b>0.87%</b>	<b>4.4%</b>	<b>20%</b>	<b>41%</b>	<b>31%</b>	
<b>I know who the experts in the topics/tools I work with are</b>						
Academic	1.9%	1.9%	15%	38%	36%	
RI	0%	14%	32%	37%	16%	
SME	1.3%	0%	3.8%	41%	53%	
Large	0%	4.2%	13%	50%	33%	
<b>All participants</b>	<b>0.87%</b>	<b>5.2%</b>	<b>16%</b>	<b>40%</b>	<b>35%</b>	
<b>I need to increase my knowledge in order to do my job</b>						
Academic	0%	5.7%	19%	43%	25%	
RI	1.4%	2.7%	34%	30%	29%	
SME	2.5%	15%	19%	35%	28%	
Large	0%	8.3%	29%	33%	29%	
<b>All participants</b>	<b>1.3%</b>	<b>8.3%</b>	<b>25%</b>	<b>35%</b>	<b>27%</b>	
<b>My organisation's current knowledge management practices work well</b>						
Academic	5.7%	23%	36%	17%	9.4%	
RI	18%	23%	37%	14%	5.5%	
SME	6.3%	20%	40%	24%	5.0%	
Large	17%	46%	29%	8.3%	0%	
<b>All participants</b>	<b>11%</b>	<b>24%</b>	<b>38%</b>	<b>17%</b>	<b>5.7%</b>	

Table 3.2: Participant opinions on knowledge related matters at their organisations. Numbers do not always add to 1 as some participants declined to answer. Results shown to 2 significant figures.



It is notable that only a small fraction of participants in any of the organisations think their current practices work well. There is no clear difference between academia and industry, though the research institution is particularly poorly rated for knowing where to go for help or who experts are.

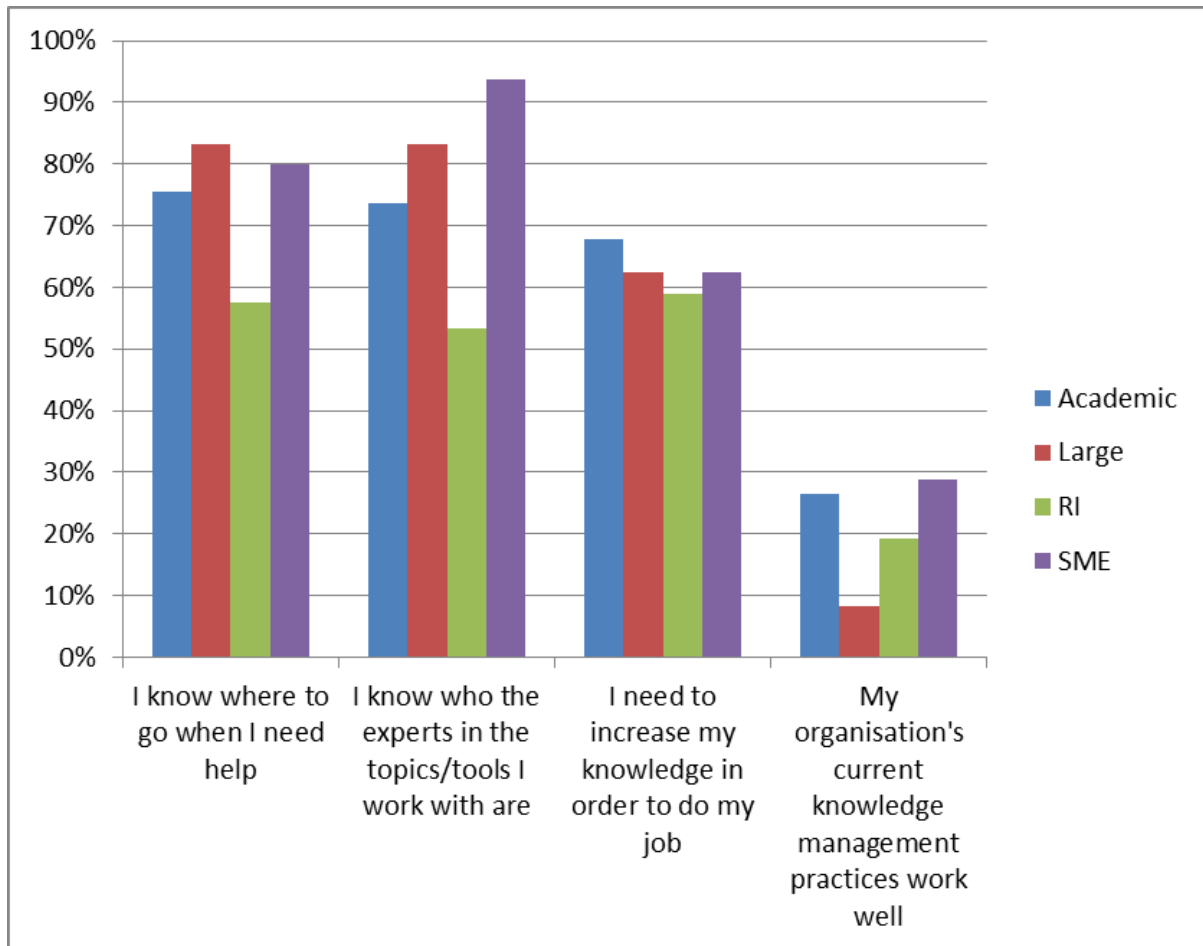

Figure 3.27: Percentage of participants who agree (4 or 5 out of 5) with the statements given.

### 3.5.3.2 Tasks during a project

Participants were given a list of information and knowledge related tasks often carried out during projects and asked whether they and their teams carry out these tasks. Answering yes (y), sometimes (s) or no (n), the results are shown below.

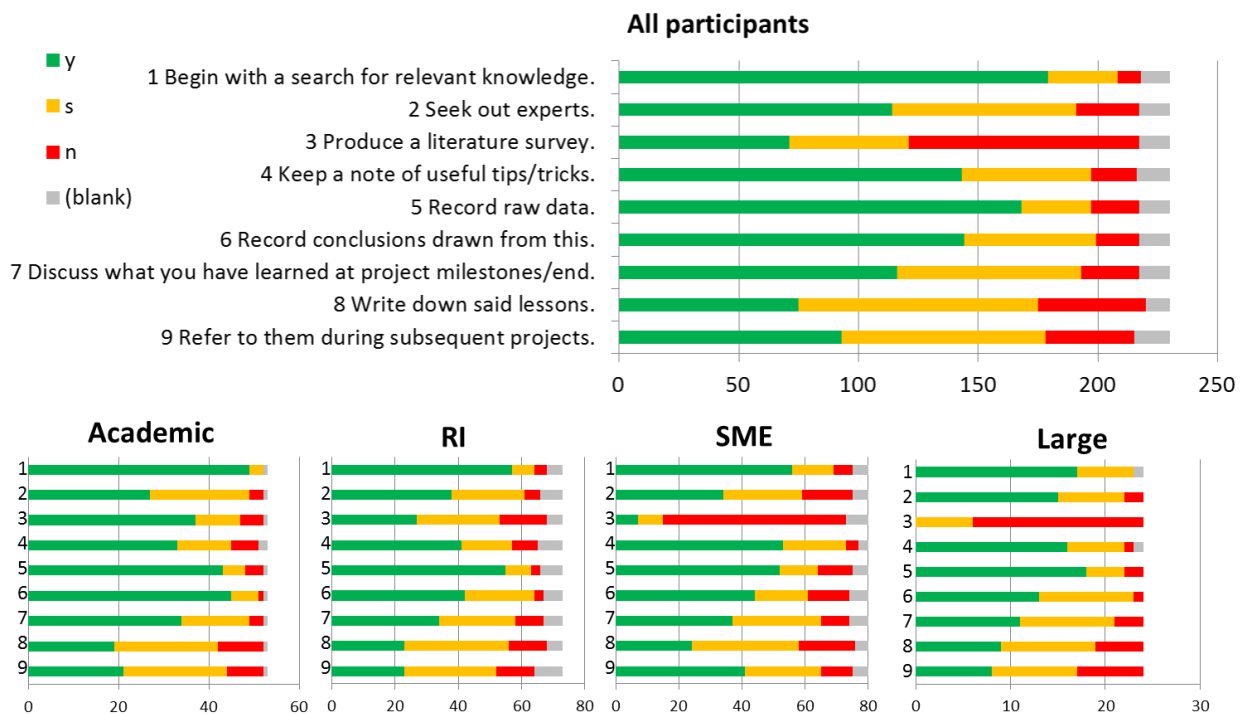

Figure 3.28: number of participants who answer yes (green), sometimes (yellow) or no (red) when asked whether or not they or their teams carry out the listed tasks.

The tasks are all clearly useful to projects, and a few interesting trends can be seen. Perhaps unsurprisingly, literature surveys are rare in industry. In SMEs in particular, more people refer to lessons learned on a previous project than record those lessons in the first place- presumably relying on their own memories. In general lessons learned practices appear poor.

Recording of lessons learned during a project is vital to keeping useful information in a business- however, this is only of use if those lessons are referred to in subsequent projects. Without a process to encourage those working on the next large equipment project to refer to them- or indeed building key lessons into business processes more generally- staff on the next project might also find themselves in conflict with the supplier over whether or not they are contractually obliged to deliver something that fits into the room stated on the documents and measured on their site survey, or whether or not they can charge extra for a cooling system that does not break the law.

### 3.5.3.3 Current knowledge transfer practices

Participants were asked to rate their organisation's current practices from 1 (useless) to 5 (very useful). As practices differ significantly between organisations- and in the case of the research institution, between teams within the organisation- making a general comparison is difficult. There are only four categories which were common to all the organisations in the study.

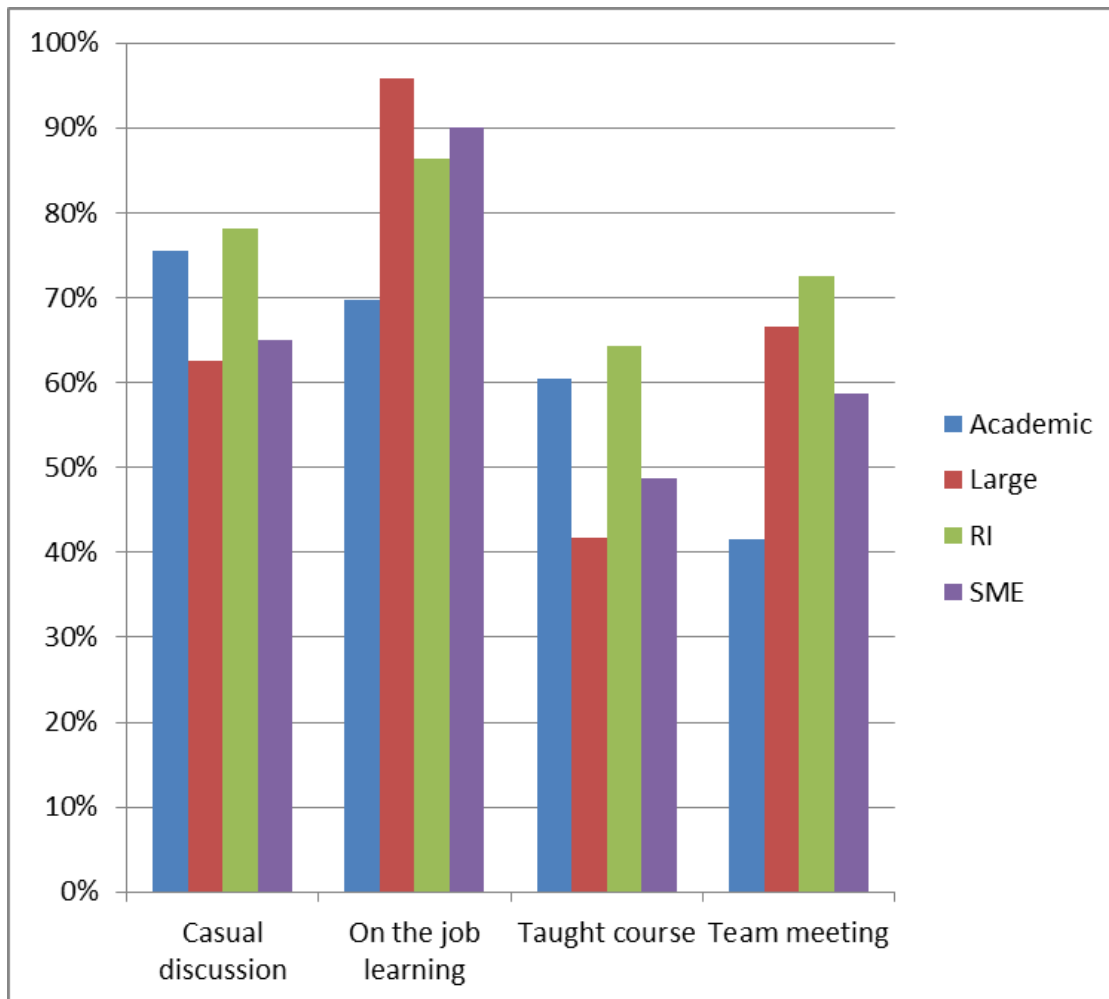

Figure 3.29: Percentage of participants in each organisation type who consider the listed knowledge transfer methods useful

It is notable that all four of these categories relate to interpersonal learning. Both meetings and on the job learning are considered more useful in industry and in the research institution than in academia. Taught courses are notably less popular in industry, both in SMEs and larger companies, though still rated reasonably highly, as almost half of participants in these organisation types consider them useful. Casual discussion, often over a cup of tea, is relatively popular in all organisation types, but more so with academics and RI staff.

### 3.5.4 Preferences for learning

Participants were asked ‘where do you go first?’ when searching for the answer to a specific question or fault, and when searching for general understanding of a topic. They ranked the options, beginning with 1 as their first choice. Their top three choices were collated to form Figure 3.30 and Figure 3.31.

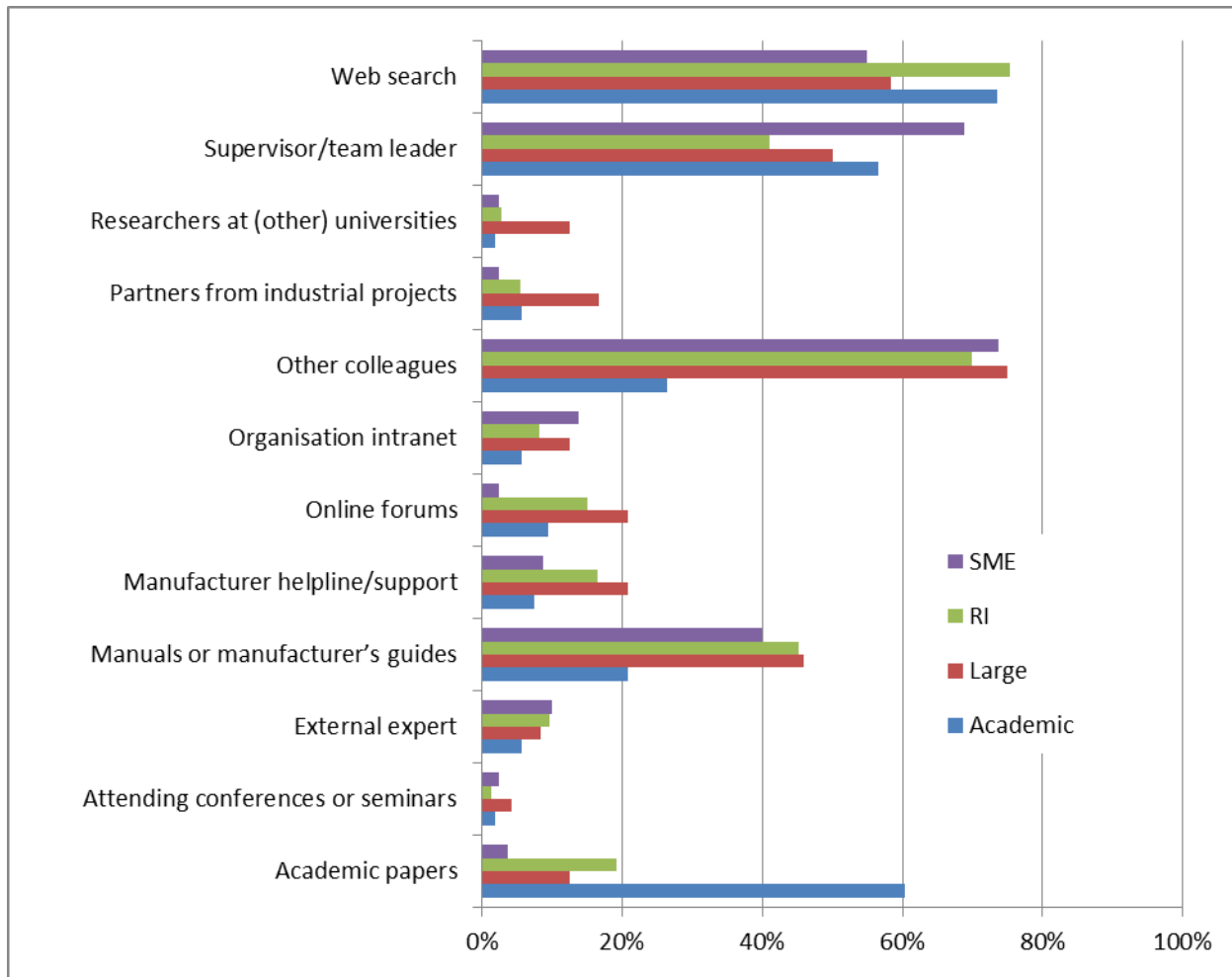

Figure 3.30: Percentage of participants who ranked these options in their top 3 choices when asked ‘where do you go to first for specific queries?’

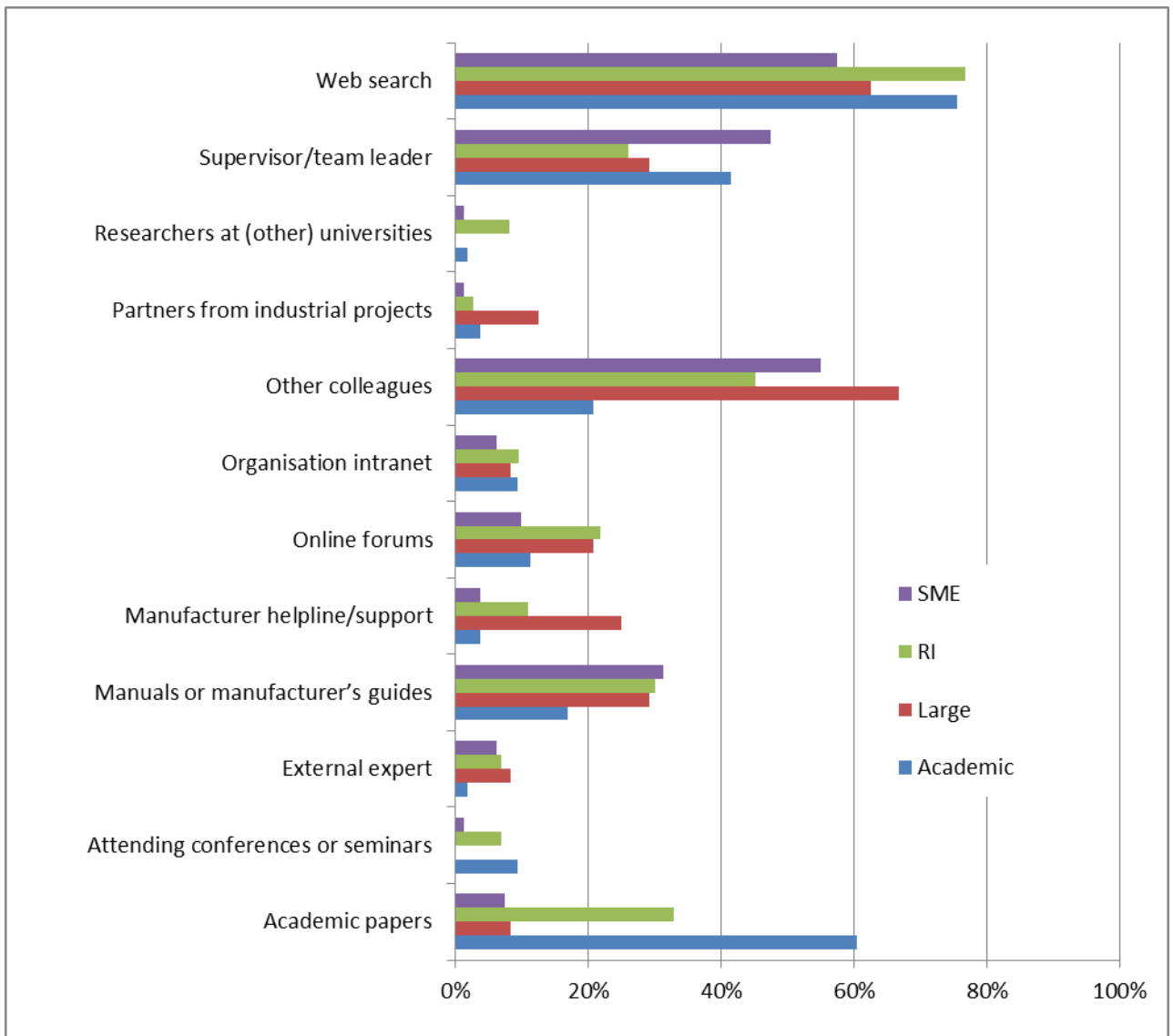

Figure 3.31: Percentage of participants who ranked these options in their top 3 choices when asked 'where do you go first for generic information'?

It is immediately clear that in both cases, web search and interpersonal knowledge transfer within the organisation- talking to colleagues or a supervisor- are popular. Recall the popularity of casual discussion and on the job learning in the previous section. Perhaps unsurprisingly, academic papers are not popular in either SMEs or Large companies. Conferences and seminars have value beyond direct knowledge transfer and are rarely in the top three choices for anyone when searching for knowledge.

For comparison, the CEOs of German automotive and biotechnology companies questioned by Plum and Hassink [203] were asked to rate the importance of different sources of information. Of the biotechnologists, considered a more 'analytical' industry by the authors, 95.7% rated academic journals as very important or important. Only 13.8% of automotive CEOs agreed.

This is not the same as asking those who carry out research related tasks on a day to day basis, but the difference between the sectors is notable. As an engineering dominated industry, composites companies have more similarity to automotive companies than biotechnology companies- indeed many automotive companies manufacture and use composite parts.

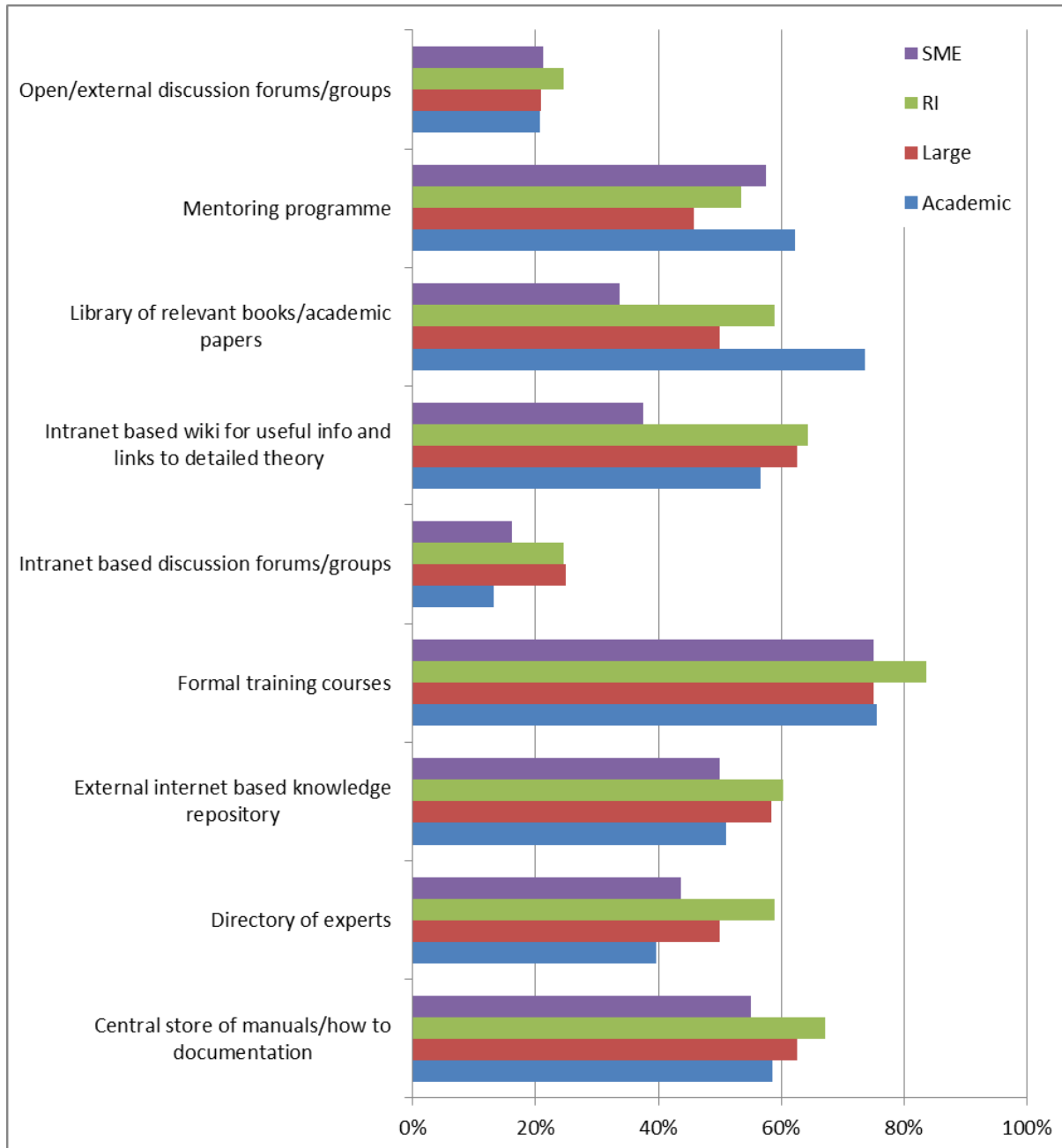

Figure 3.32: Percentage of participants who rank each option as 'useful' (4, 5 or 6 out of 5).

These results can be compared to a later question, where participants were asked to give their opinions on how useful a variety of knowledge transfer resources might be, from 1 (useless) to 5 (very useful). Ratings of 4 or 5 (or in one case, 6) out of 5 were used to make Figure 3.32.

In the ECCM paper [50] published with preliminary results from the Canadian organisations, UK academic group 1 and the pilot group of the research institute, it was notable that far more people rated a central store of manuals highly than those who said they currently go to manuals or manufacturer's guides. The effect is less obvious here- the proportion of people who would go to manuals is still similar, but other options (web search, colleagues etc) have dropped in popularity in the larger set of results. ~30% (generic) or 40% (specific) of participants in the full study say manuals are in their top 3 choices now, whereas ~60% rate a central store of manuals/how to documentation as useful or very useful.

A smaller proportion of academics rate manuals in their top three choices now, but the number who consider a central store of manuals useful is comparable to the other organisation types.

Despite the popularity of web search and learning from other people, discussion forums- either external or internal- are considered less useful than the other options, though an internet based knowledge repository or internal wiki are both reasonably popular. A possible reason is shown in Figure 3.33.

Formal training courses- an interpersonal form of knowledge transfer- are the top choice in all organisation types, showing a clear demand for training in all areas of the composites industry.

### 3.5.4.1 Willingness to contribute to a wiki or forum

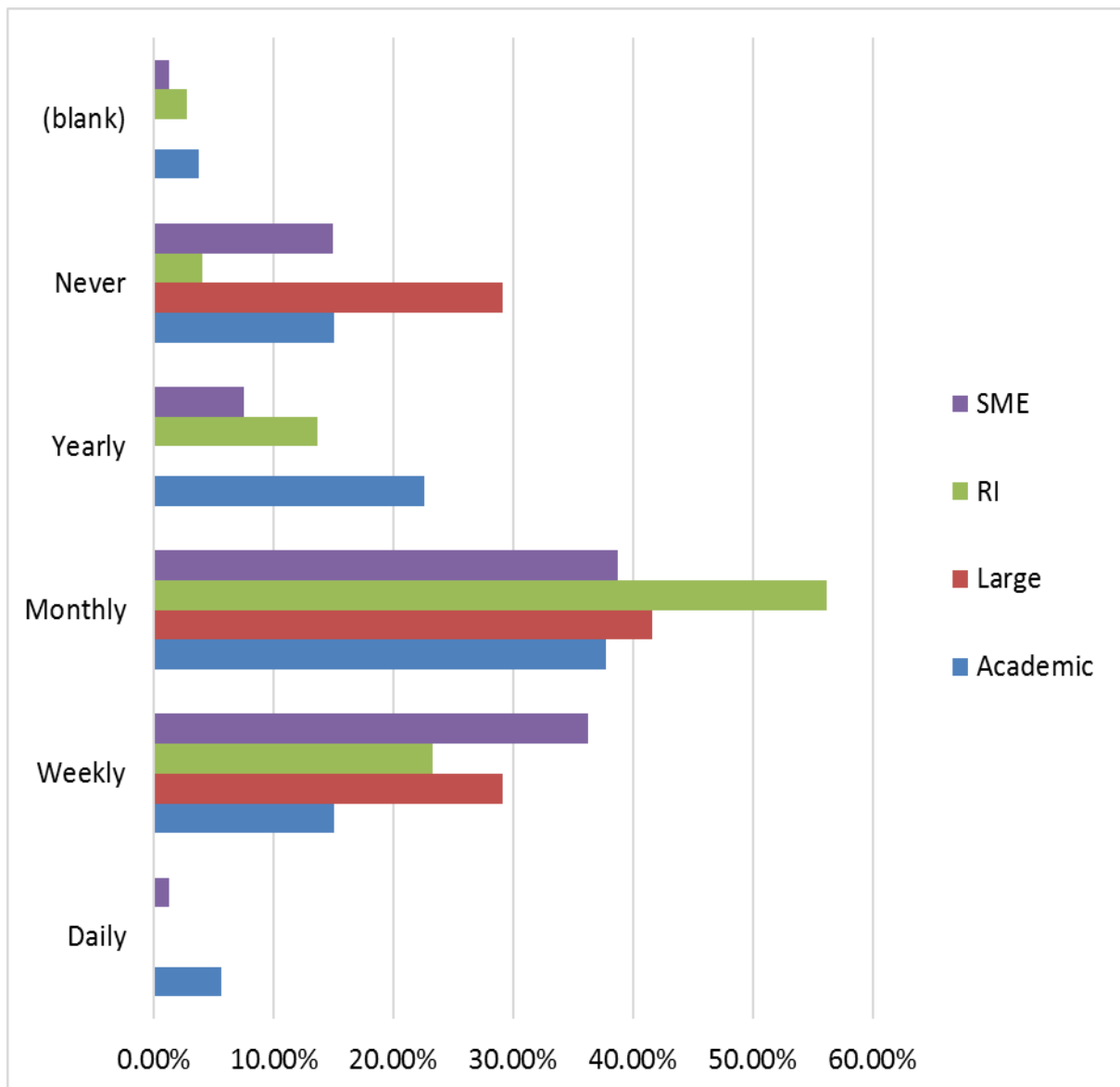

Figure 3.33: How often would you be willing and have time to contribute to a wiki or forum? Percentage of participants by organisation type.

A wiki or forum depends on user contributions. These are therefore only practical options if participants are both willing and have time to contribute to them. As shown in Figure 3.33, very few people from any organisation type would be able to do this daily, making the pace of discussion in a forum unsuitable for most organisations. However, with many willing and able to contribute on a weekly or monthly basis, a wiki, with user generated content, is a feasible option for all organisation types. Figure 3.34 shows that there is no noticeable correlation with job type, suggesting that those who do not have computer-based jobs would be able to contribute too.



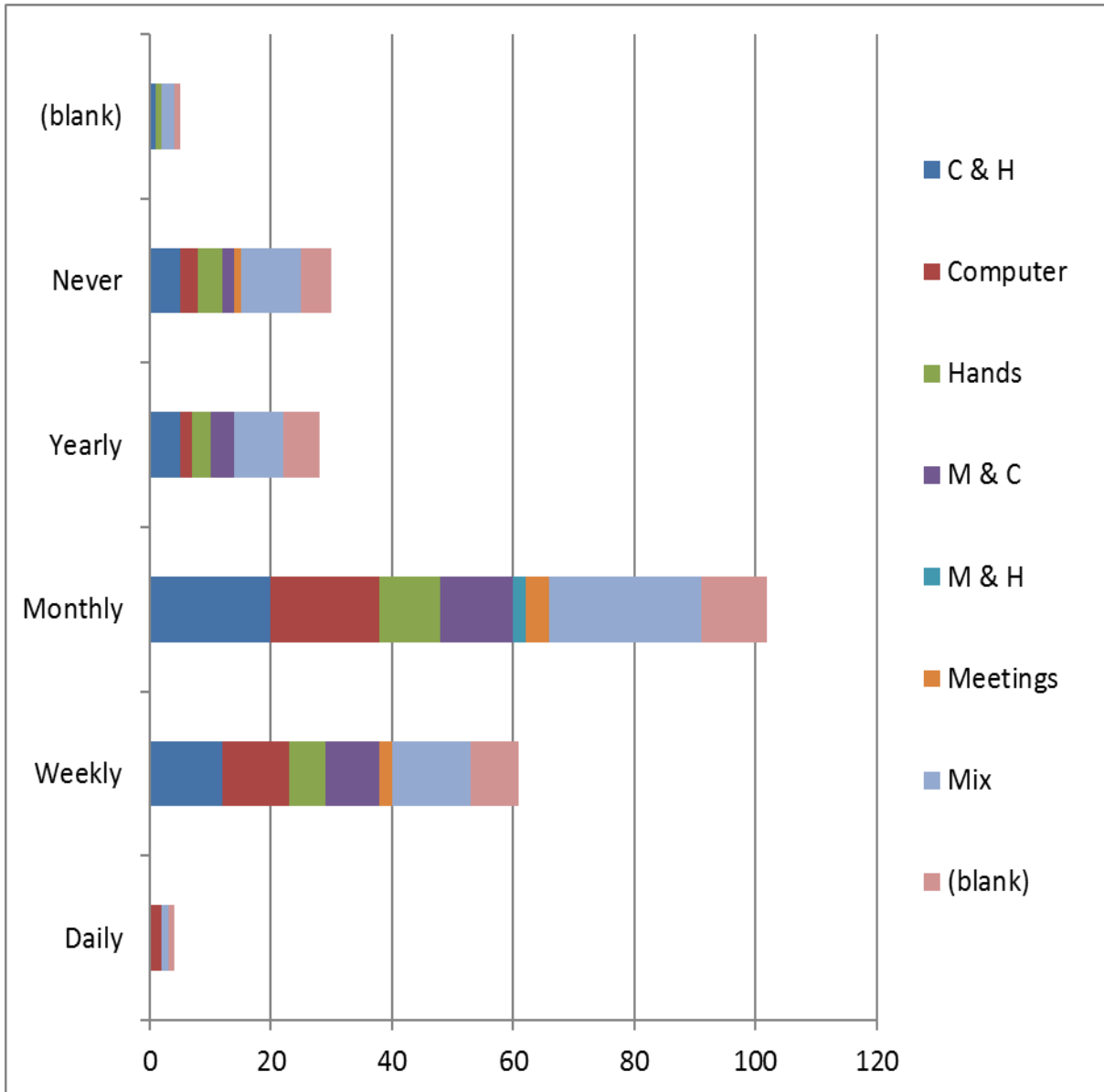

Figure 3.34: How often would you be willing and have time to contribute to a wiki or forum? Raw number of participants shown by job type, across all participating organisations.

### 3.6 Conclusions

A study of knowledge transfer within and between certain companies- focusing on SMEs-, academic groups and a research institution in the advanced composites industry has been carried out, using investigative techniques from knowledge management, with a view to informing and improving knowledge transfer between academia and industry.

- The study combines well known techniques including opinion based questions, knowledge network visualisations – using the push and pull network model of Helms et al- and competence matrices.
- The split between theory and practical in the competence matrices is a modification to the usual method. Addition of number and total weighting of knowledge network connections for comparison and presentation with colour coding for instant, visual gap analysis, has not been seen previously. As shown in the Company 6 case study, this form of data presentation demonstrates that persons who self-rate their knowledge highly are not always those who transfer knowledge well to others in the organisation.
- The majority of companies had no knowledge transfer links to or from the academic groups or research institution, in either push or pull networks, despite being recommended by these for participation in the study. The exception is a spin-off from the Canadian academic group. Two others have very weak links via a single person in one of the two network types.
- There were no knowledge transfer links between the UK and Canadian academic groups, though academics at each are known to communicate with the other.
- The research institution and academic group 1, which are both in the UK, are thoroughly interlinked. The community detection algorithm splits this network into cliques which contain members of both groups rather than distinguishing the two organisations. Academic group 2 and its spin-off, company 2, were assigned to a single clique.
- The opinion based questions showed no clear correlations with job type or age.
- The clearest differences in knowledge transfer methods between academia and industry relate to literature. Literature surveys are carried out in the academic groups and research institution but are rare in both SMEs and the larger companies. Similarly, 60% of academics considered papers among their top 3 choices when searching for both specific and generic information but these were not popular in the companies. The research institution ranked papers more highly for generic than specific information. Conversely, academics are less likely to refer to manuals or manufacturers guides than the other three groups- here the research institution is aligned with industry.

- Conferences and seminars are not popular choices for answers to specific queries or finding generic information, even among academics.
- All groups showed a strong preference for answering questions by web search.
- All groups were in favour of interpersonal learning. Academics were however much less likely to talk to “other colleagues” than to their supervisor or team leader, while the opposite is true, though by a smaller margin, in the research institution and teams within larger companies. 70% of academics found on the job learning useful, whereas this is 85-95% in the other organisation types. Academics also found team meetings much less useful (40%) than the other groups (55-75%). Taken together, this suggests that teamwork may be less popular or less useful in academia than in industry.
- Training courses, ‘if they were available’ are considered useful by the largest proportion of people in all organisation types. Existing taught courses are considered less useful by staff in companies than those in academia or the research institution.
- A larger percentage of people in all organisation types consider a central store of manuals/how to documentation to be useful than rank manuals or manufacturers guides in their top 3 choices for either generic or specific queries, though this is ranked notably higher in the latter for all except the academics.
- The majority of participants would have time and be willing to contribute to a wiki or forum, but as few would be able to do this on a daily basis a wiki is likely to be the better option of the two. There is no correlation with job type (computer, hands-on, meetings or combinations of the three).
- The research institution has a notably smaller proportion of persons who know where to go when they need help, or know who the experts in the topics/tools they work with are, compared to the other three organisation types, indicating a problem with “know-who”[167].
- Over half of participants in all organisation types think they need to increase their knowledge in order to do their jobs.
- Very few participants agree with the statement “My organisation’s current knowledge management practices work well”.

Ghaziri and Awad [169] discussed the importance of individual personality in knowledge transfer, suggesting that a “moody expert” may not easily communicate their knowledge to others. The results from Company 6 suggest that this could be extended to the working culture in a group, as the contrast between the well interlinked fitting team and the isolated experts in the laminating team suggests a distinct lack of knowledge transfer in the latter.

In addition, there is only one person linking the two teams. This is a dangerous situation, similar to that shown by Cross et al [191] and between teams in the pilot group study, as if this person leaves there is no link at all, and knowledge can easily become siloed in each team, forming a knowledge horizon and making it difficult to see the bigger picture [179]. To tackle this problem, it may be worth considering forming links between the laminators and fitters- for example, if a laminator who has laid up a particular part delivers it, once cured, to the responsible fitter and they discuss any issues, ideas or complications between them. This facilitates organisational learning as they may find potential improvements, such as adjustments to the layup which could make the fitter's job easier, which could, subject to approval, be tried on the next version of the part. In addition, by linking the less communicative laminators with the more communicative fitters, links between laminators may be created through fitters acting as knowledge brokers and perhaps also encouraging direct discussion between laminators. Depending on their personalities [169] some or all of the more expert laminators could also be given training to help them transfer knowledge to others, and/or incentives to do so. The lone laminator who does teach one other person could also be given training and challenges to increase their expertise and encouraged to teach others.

Company 8, by contrast, has a robust network, meaning that if a single individual leaves the network does not split, and the wealth of high viscosity [31] links allow knowledge to be transferred to others before they go. Each expert communicates their knowledge to many others, which may create bottlenecks [31] if the expert's time is limited, so this company should consider setting aside time for this and monitoring the situation to ensure no-one becomes overwhelmed, training people to share the load or rotating new staff around experts so that each only teaches a small number at any one time if necessary.

It was expected that the combined knowledge networks would show an interconnected group in the UK and another in Canada, with a few links between the two academic groups. This was not the case. The author of this thesis, who did not participate in order to avoid bias, could be considered a single link between the two academic groups. It is known that academics from the groups do communicate, but clearly neither one feels they learn, either by push methods or through asking questions, from the other.

The lack of connections between the companies and academic groups and research institution is a matter for concern, particularly as connecting academia with industry is part of the remit of the research institution. It must be noted that this relates only to the companies in this study, which focuses on SMEs- it is likely that the picture for large companies is very different, especially as some have staff permanently on-site at the research institution.

However, SMEs, lacking resources for large research and development departments of their own, could benefit greatly from better connections with academia, through the research institution, and are more likely to have the flexibility to deploy new innovations quickly, hence the focus here. The research institution has recently begun a new initiative intended to improve links with SMEs.

Studies of other industries show many links between academia and SMEs, however the majority of these construct network diagrams using proxy measures such as lists of collaborators [199]–[202]. Using such proxy measures, the companies included here would be linked to the academic groups/research institution in their respective countries. The lack of any knowledge transfer links identified by individual employees, despite encouragement to consider persons outside their organisation, suggests that these proxy measurements may not be representative of knowledge transfer relevant to a learning organisation, where personal mastery- learning by the individual- and team learning resulting from those individuals working together and transferring knowledge between them are among the vital disciplines [179]. If the individual employees do not identify any knowledge transfer resulting from the theoretical connections between organisations, it seems learning is not taking place.

Studies carried out by interviewing CEOs also result in networks with connections between SMEs and academic/research institutions in other industries [203]–[205]. McDermott et al's [206] study of the wine industry in two Argentinian provinces is a better comparison, as they interviewed knowledge workers at the various institutions, in addition to the usual CEOs and directors. Here many Government Support Institutions (GSIs), have been created to provide research and development programmes and training in the wine industry. All wineries had links to at least one GSI, with some GSIs acting as hubs for many wineries. This is a notable contrast to the result obtained with the composites SMEs, research institution and academic group, though it should be noted that McDermott et al's research [206] included a greater number of organisations this study.

Knowledge network analysis using the method employed here or similar, where individual employees identify those they learn from [191], [220]–[222] is commonly used in studies of single organisations. Where those organisations have multiple sites, having only 3-4 knowledge transfer links between sites was considered problematic [191]- a complete lack of connections is not seen in any of these studies [191], [220]–[222].

The academic groups- and the research institution in particular, due to its remit- should work towards forming knowledge transfer links with these SMEs and others in order to encourage technology transfer from academia to industry.

McDermott et al [206] argue that “*product upgrading depends on a firm’s being tied not simply to any or many organizations and GSIs, but rather to those that act as social and knowledge bridges between distinct producer communities and in turn offer firms access to a variety of knowledge resources*”. This suggests that academic groups and research institutions should seek to encourage knowledge transfer not only between themselves and SMEs but facilitate links between companies too.

The results show that interpersonal knowledge transfer is popular, particularly in industry, and there is demand for taught courses. It would therefore make sense for the research institution to provide such courses, targeted at SMEs in particular, in topics relevant to them while demonstrating technologies which are under development or ready for industrial use but not well known, facilitating both knowledge links and technology transfer. The equipment and methods demonstrated should have manuals and guidance documents.

It may be beneficial to assign specific individuals within the research institution to talk to particular SMEs, so that the company staff can ask questions of a person they are familiar with. This person could visit the SME site to demonstrate potentially useful technologies, perhaps after interest is shown following a course. The research institution has an internal problem with know-who: developing a directory of expertise could be useful both for internal staff reference and for identifying the best people to talk to a particular company or to deliver training on a particular technology.

Such courses could be taught by research institution or academic staff, and networking both with other participants- such as through group exercises- and other staff at the research institution should be encouraged. To encourage relevant knowledge transfer, discussions can perhaps take place while being shown relevant equipment in the workshop. Hands-on exercises are to be encouraged as this is a higher viscosity form of learning [31]. As SMEs may struggle to free staff from their day to day work, such courses should be short and scheduled to fit business needs as far as possible (e.g. to coincide with planned down time for maintenance). Provision of resources for reference and which an SME staff member could share with their colleagues would be useful, as it is unlikely that all staff would attend such a course. As web search is a popular choice when searching for knowledge and internet based knowledge repositories are considered useful by 50% of SME participants, such a knowledge repository, crafted for industrial use and kept up to date by the research institution or their academic partners, could be very useful.

These factors contributed to the trial of a taught course in dielectric cure monitoring, production of human-fronted videos- as the closest substitute when a course is not available and as a web based resource- and a PowerPoint based clickable knowledge transfer resource, which is discussed in Chapter 6.

Notably, very few participants at any organisation involved in this study think their current knowledge management practices work well and recording of lessons learned is generally poor. This demonstrates the need for good knowledge management in the composites industry. A study of this type can be used to find where improvements is needed and which options are likely to fit well with working practices. The change in the pilot group between the first and second runs of the questionnaire show how useful the knowledge network visualisations in particular can be in facilitating this. Most managers were unfamiliar with these techniques, and none of the organisations carried out studies of this nature regularly. It may be beneficial to do so, building it into a yearly review process and monitoring the effects of any changes introduced.

The research institution could offer this as a service and combine it into a wider study, as carried out here, which would also allow monitoring of the effects of any efforts made to improve knowledge transfer links with SMEs.

# Chapter 4

## 4 In-Process XCT Scanning to Track Evolution of Prepreg Features During Cure.

### 4.1 Abstract

An increased understanding of how features such as voids change during the cure process can inform design and manufacturing process choices. This chapter presents the detailed evolution of a prepreg defect throughout the cure process, using a novel method of In-Process Micro-XCT.

A Nikon XTH-320 industrial CT scanner was equipped to allow heating and curing of a prepreg sample under vacuum, for consolidation. Short scans of approximately 7 minutes were performed repeatedly during cure.

The evolution during cure of voids resulting from two defect types typical of Automated Fibre Placement (AFP) processes, representing a tow gap and a ply drop, is presented, using M21 unidirectional carbon fibre prepreg. The results are compared to a cure kinetics model for the resin. In-process micro-CT has the potential to provide far more detailed information on the behaviour of composites during cure than has been available prior to today. This work provides both proof of the principle, as an experimental method, and new understanding of defect evolution during cure.

### 4.2 Introduction

Composite parts may be designed to exacting standards, with layup guidelines requiring accuracy of a fraction of a millimetre. Achieving this in practise is very difficult. In some instances the geometry makes defects unavoidable. [4] Understanding how a defect introduced in the initial stages of manufacture evolves and changes as the composite is cured may inform design and manufacturing choices, particularly with respect to defining tolerances for defects.

Tracking the evolution of a defect during cure is one way to do this. While it has previously been possible to take XCT scans at different stages of the cure by quenching a number of partially cured samples at different stages [27], [28] there is inevitably variation between samples and the quenching process may affect the result. This novel method gives us the ability to track a defect, in a single sample, through the entire cure process.



Knowing how far ply drops might move during cure can give a realistic guide to what layup accuracy might be needed. Following the filling- or not- of a gap, and any further behaviour, indicates whether or not this is likely to be a problem later on and teaches us more about the material behaviour.

In an industrial CT scanner, the sample is rotated through 360 degrees while exposed to X-rays. The number of projections, or images, per scan and the exposure time of each image determine how long the scan will take. As longer scans average the image detected over a larger period of time- with multiple hour scans being the norm for a static composite sample- the signal to noise ratio is better; however in order to capture the changes in a curing sample, we need a very short scan time.

Industrial CT scanners have been used to track the changes in objects over time before, with the most relevant being Plank et al's 2016 work following a bubble of water during the cure of neat resin [150]. This experimental method, developed independently of their work, bears some similarities to theirs- in that a sample is heated while under vacuum- but the requirements for a composite prepreg sample and evaluation of the voids therein are very different. In-process XCT Scanning of composites has been carried out using synchrotrons, including for resin infusion [145], debulking [147] and compression moulding [148]. Synchrotrons can produce a high quality and high magnification image but are expensive to use and not widely available in industry, therefore an industrial CT scanner is more practical. The principles of XCT scanning of changing samples, with examples, are further discussed in Chapter 2.

The test samples were made from Hexcel's M21 prepreg as this is a widely used material, representative of aerospace grade carbon fibre-epoxy prepreg. It should be noted that M21 is not an out of autoclave prepreg, so curing under only the equivalent of 1 bar pressure (from the vacuum pump) is expected to result in more voids than the manufacturer's recommended cure cycle. For the purpose of the proof of principle, this means one should expect detectable voids to be present, and the results can give insight into the resin behaviour. A more realistic cure would require development of an X-ray transparent pressure vessel, which goes beyond the scope of this work.

#### 4.2.1 Defect types

- 1) Tow gap: An approximately 2mm wide, 2 ply deep gap along the fibre direction at the centre of a (0,90) layup, of the type which might reasonably occur during manufacture with either manual layup or Automated Fibre Placement. This can be compared to the tow gaps studied by Rhead et al [154], which had a significant effect on sample compression after impact. In this configuration lateral fibre movement is expected to occur, as fibres from either side of the deliberate large void may move into it.

- 2) Ply drop: An approximately 2mm, wide, 2 ply deep gap cut across the fibre direction at the centre of a (0,0) layup, as might occur when prepreg is cut at the end of an AFP tape [153] or an error is made in manual layup. As fibres are not expected to move laterally in this configuration, only resin movement and vertical deformation of the plies above and below the deliberate large void should contribute to the evolution of the defect.

Note that some of the results for the tow gap defect presented herein were previously published by the author and colleagues in an ICCM paper. [47]

#### 4.2.2 M21 cure

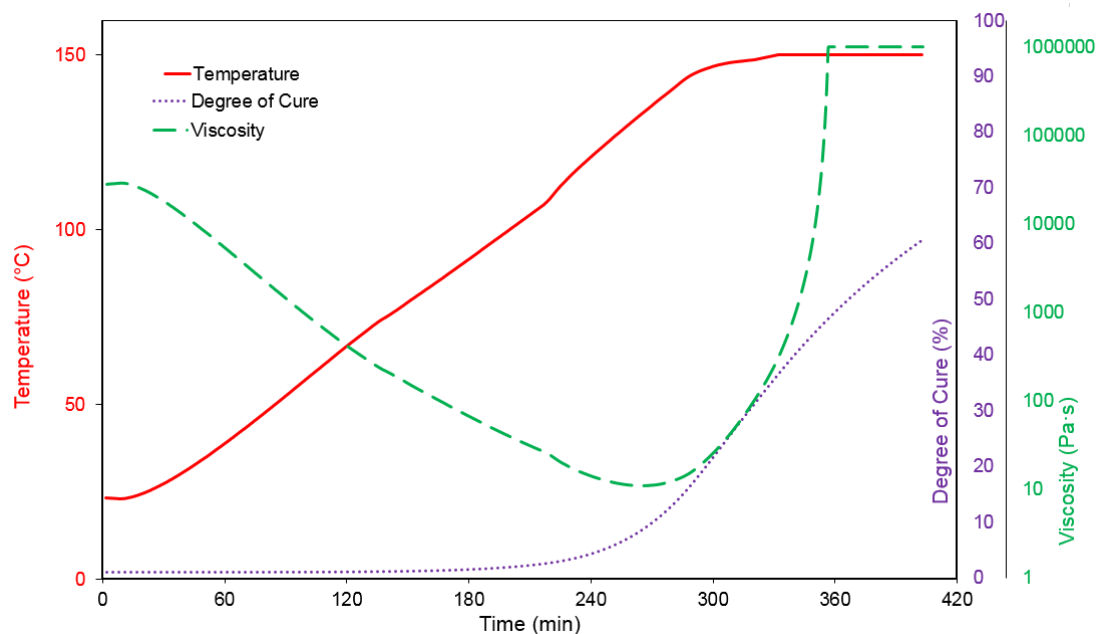

Figure 4.1: M21 viscosity (green) and degree of cure (purple) over selected cure cycle (temperature in red). Based on cure kinetics model of Kratz et al. [43]

The cure cycle was as shown in Figure 4.1- a slow ramp of approximately  $0.45^{\circ}\text{C}/\text{min}$  to a temperature of approximately  $150^{\circ}\text{C}$ , hold for 2 hours then cool naturally by turning off the heat source. The hold temperature was chosen to ensure the heat was sufficient for gelation and some curing to occur, but not likely to risk a fire in the highly expensive XTH-320 CT scanner [223].

A typical autoclave has a temperature accuracy of  $\pm 2$  to  $3^{\circ}\text{C}$  [123], meaning variation of 4 to  $6^{\circ}\text{C}$  can be considered 'constant temperature' by industrial standards. During a short scan of 7 minutes, the temperature of the sample will increase by an average of  $3.15^{\circ}\text{C}$ , well within this variation.

Furthermore, the slow ramp allows numerous scans to be taken during the interesting phases of viscosity decrease and sample consolidation where the most movement is likely to be seen, without compromising too much on scan quality.

### 4.3 Initial experiments

The very first trials intended only to find out whether curing using a heater mat in direct contact with the sample was a viable option. The heater mat was held flat, vertically, with a composite sample in contact with it. It was quickly determined that noise from the wires inside the heater mat were too much of a problem. Having decided on a cylindrical sample in order to keep the horizontal thickness of material constant during rotation, the decision was taken to use a heater mat held out of the X-ray zone to heat a ceramic rod, which acts as a heated tool. Vacuum- initially from a static pot- was used to induce consolidation in the sample.

For initial tests, a battery powered heater mat was used. This was sufficient for proof of concept, but did not reach a high enough temperature for cure, so Nikon were employed to thread a power cable into the X-ray cabinet (Figure 4.2) - along with a vacuum line and USB cable for thermocouple reader output. This also allowed a more reliable vacuum to be applied than is possible with a standalone pressure pot at the lowest reasonable pressure.

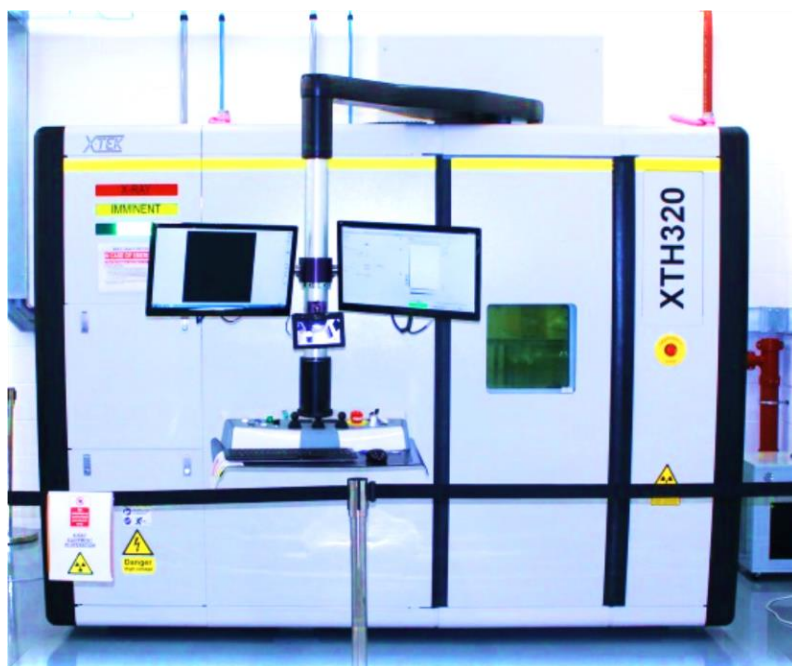

Figure 4.2: Nikon XTH-320 CT Scanner

#### 4.3.1 Building work nearby

A CT scanner is a very delicate machine. Drilling taking place in the workshop next door was sufficient to vibrate the filament out of alignment, making the first test scans unusable. The only solution is to avoid vibration around CT scanners- or put the scanner out of use if such is unavoidable.

#### 4.3.2 First proof of concept

A sample with a random selection of defects, made of M21 carbon fibre prepreg with interspersed M21 glass fibre plies to highlight layers, was used for the first successful In-Process XCT Scanning run. Consolidation could clearly be seen and the glass fibres were confirmed to work as tracers. 7 minute scans were used.

The figures below show the first X-ray images of a composite sample as it cures. A micro-XCT scan, once reconstructed, results in a three-dimensional model of the sample. A slice halfway through this model is shown, taken from the start of the cure, intermediate points, and the end point. The millimetre-scale gaps can be seen to shrink, though not disappear entirely, as the cure progresses. The bright dot, circled on scan 15, is a high density contaminant.

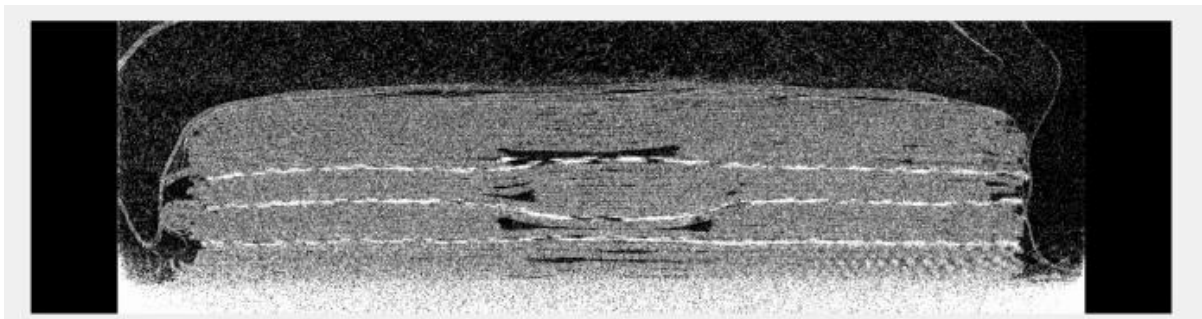

Figure 4.3: Start of cure

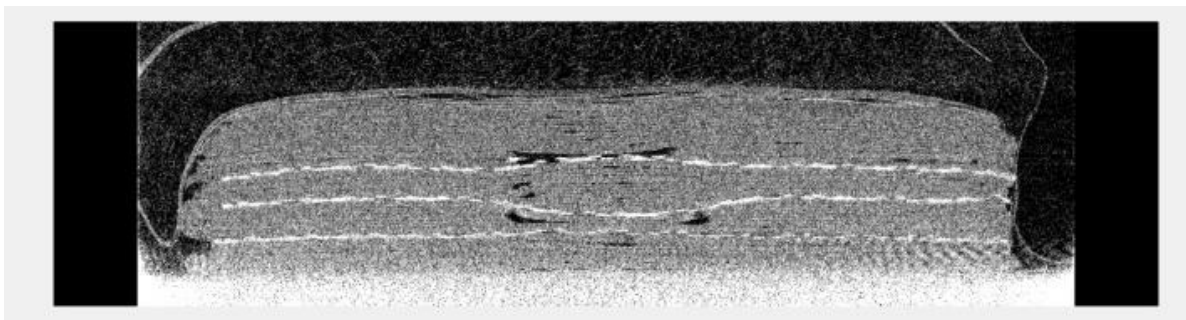

Figure 4.4: Scan 5 (40 minutes)



Figure 4.5: Scan 10 (90 minutes)



Figure 4.6: Scan 15 (140 minutes), high density contaminant circled

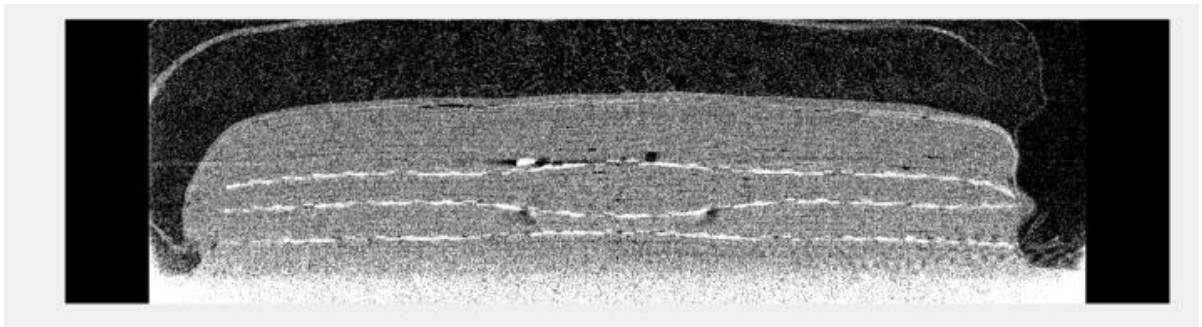

Figure 4.7: Scan 20 (190 minutes)

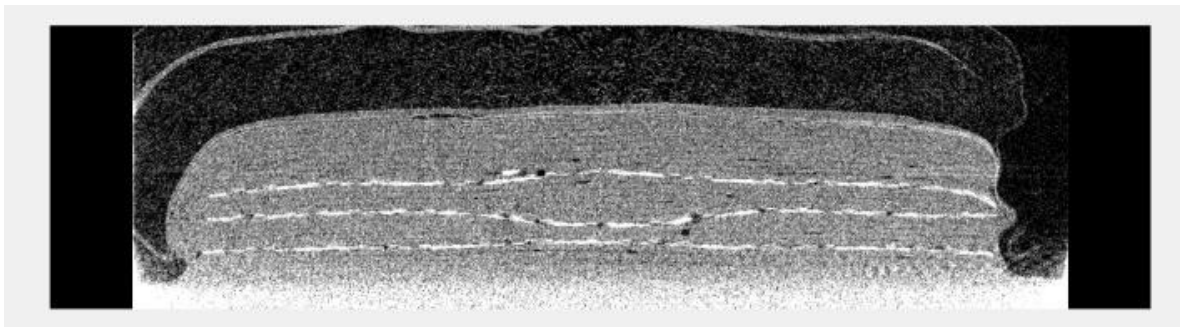

Figure 4.8: Scan 25 (240 minutes), cooling

#### 4.3.2.1 Thermocouple positioning

The proof of concept images show a lot of noise. In these images, the thermocouples were, while below the image zone, close to the X-ray zone near the top of the ceramic. Moving the thermocouples to the base of the ceramic significantly improved the image. However, some noise remains- from the ceramic itself. Future implementations should consider different materials for a heated tool, or a different heating strategy.

#### 4.3.2.2 Sample slippage

The proof of concept sample can be seen moving to the left in the above sequence of figures. To provide a constraint, so the sample represents a small defect in a larger part, acrylic rings were used thereafter to stop slippage. Acrylic lids were also made, to ensure the vacuum was applied evenly.

#### 4.3.2.3 *Shading correction*

The shading correction records the X-rays received at the detector, without a sample present, at a number of different intensities. These 'pictures' are normalised to the detector range, resulting in a correction which is subtracted from each X-ray image during a scan, removing any artefacts due to the detector. The shading correction was initially normalised to the whole range of intensities, however, on advice from Nikon, for later runs this was corrected to stop slightly below the maximum, so that any cosmic rays or other noise which impact the detector during a scan at higher intensity than the test range do not skew the results.

In the earlier trials, the CT scanner automatically took a second shading correction part way through, this shifted the timings slightly. The expiry time of the shading correction was changed so that this would not be necessary, resulting in a successful scan at regular intervals as desired.

#### 4.3.2.4 *Scan settings*

Initial tests used 4 minute scans, but these were too noisy to analyse. Trial and error resulted in a reasonable balance between noise and scan time for a 7 minute scan, consisting of 1600 projections, each with a 250ms exposure. At 7 minutes, the scan can be reconstructed without blurring. A longer scan would risk this as the sample is in motion as it cures. The scans were automatically carried out using a batch program.

#### 4.3.2.5 *Sample positioning*

Initial experiments aimed to achieve the maximum possible magnification, meaning sample positioning took a significant amount of trial and error, as the whole sample must remain in view during a 360 degree rotation- leading to many very small adjustments to get this right.

For later experiments, the power was increased slightly as the higher X-ray flux provides a greater signal to noise ratio for the small exposure time. This resulted in a slightly larger minimum spot size [135], so there was no longer an advantage to a resolution less than 13 $\mu$ m.

As the ceramic heats, the tooling blocks which protect the clamp from the heat can soften. The clamp is placed at the base of the ceramic (keeping the metal out of the X-ray zone) and fastened tightly to prevent inadvertent sample movement. As the tooling blocks soften, the clamp pushes inwards, pushing the sample up and out of view. This was counteracted by slightly loosening the clamp and taping the tooling blocks and ceramic very firmly in place.

#### 4.4 Experimental setup

The scanning was conducted using a Nikon XTH-320 CT scanner with a 225keV reflection head and a flat panel detector. A vacuum line, power and USB cables were fed into the scanner cabinet to enable the experiment.

The vacuum line was connected to a pressure pot, from which a flexible hose ran to the ceiling of the cabinet, from where it could reach the sample, with sufficient flexibility to allow the stage to rotate. The sample was cured under vacuum only. An acrylic disc placed on top of the sample and in contact with the breather fabric ensured even pressure across most of the surface. The acrylic was seen to soften slightly during the cure but remained sufficiently rigid for the task.

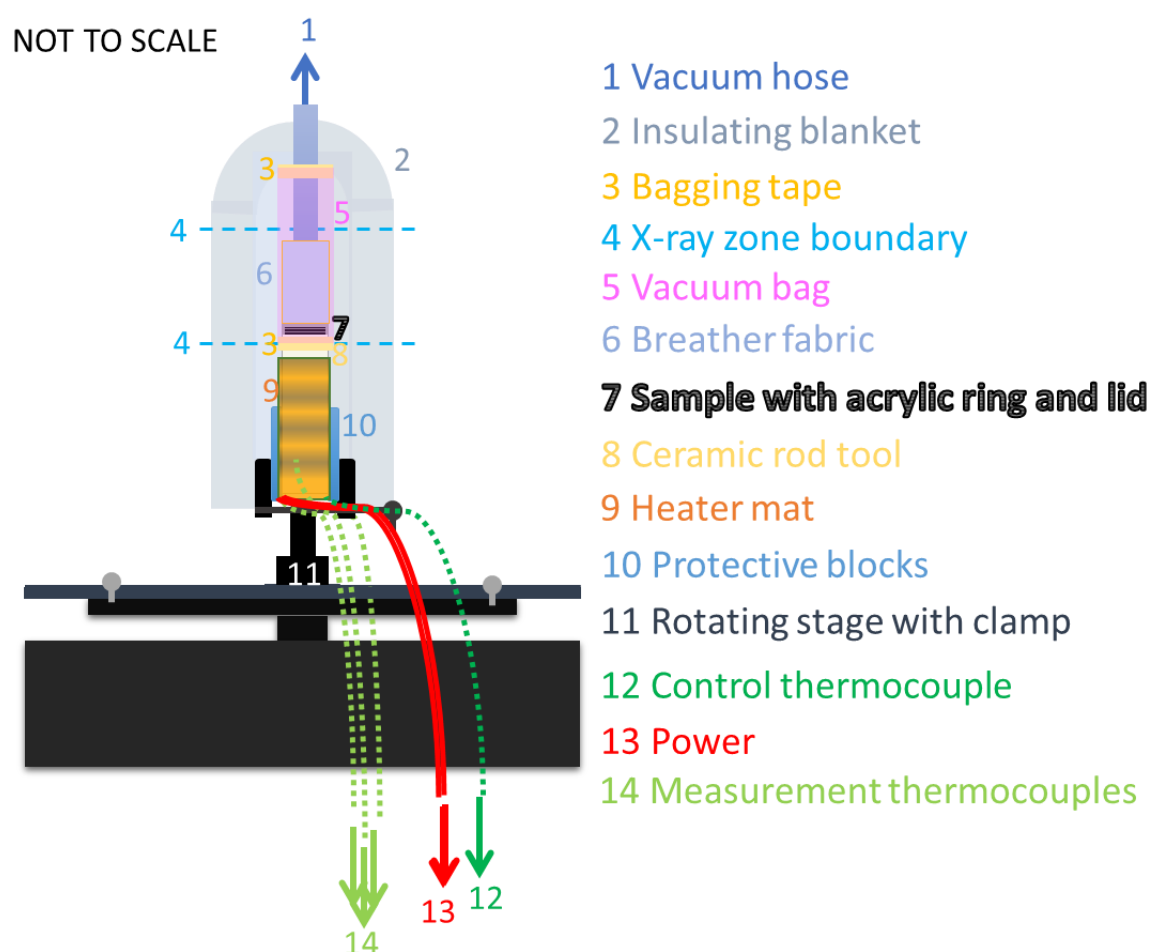

Figure 4.9: Experimental setup showing cure apparatus and sample.

The equipment was arranged as shown in Figure 4.9. The insulating blanket is made from breather cloth, which is transparent to X-rays. A small, cylindrical vacuum bag was connected to the vacuum hose and the ceramic rod tool, with breather fabric between the hose and acrylic disc atop the sample, which is constrained by an acrylic ring. The vacuum bags were made from standard vacuum bag plastic formed into cylinders using a hot seal press.



Thermocouples were placed in the bottom of the ceramic rod tool to minimise X-ray scatter in the imaging area. Heat was provided by a flexible silicone heater mat wrapped around the ceramic rod tool, with a controller placed inside the CT cabinet. Readings from thermocouples in contact with the rod and the heater mat were recorded, via a thermocouple reader and LabView software. The view inside the cabinet is shown in the photographs Figure 4.10 and Figure 4.11

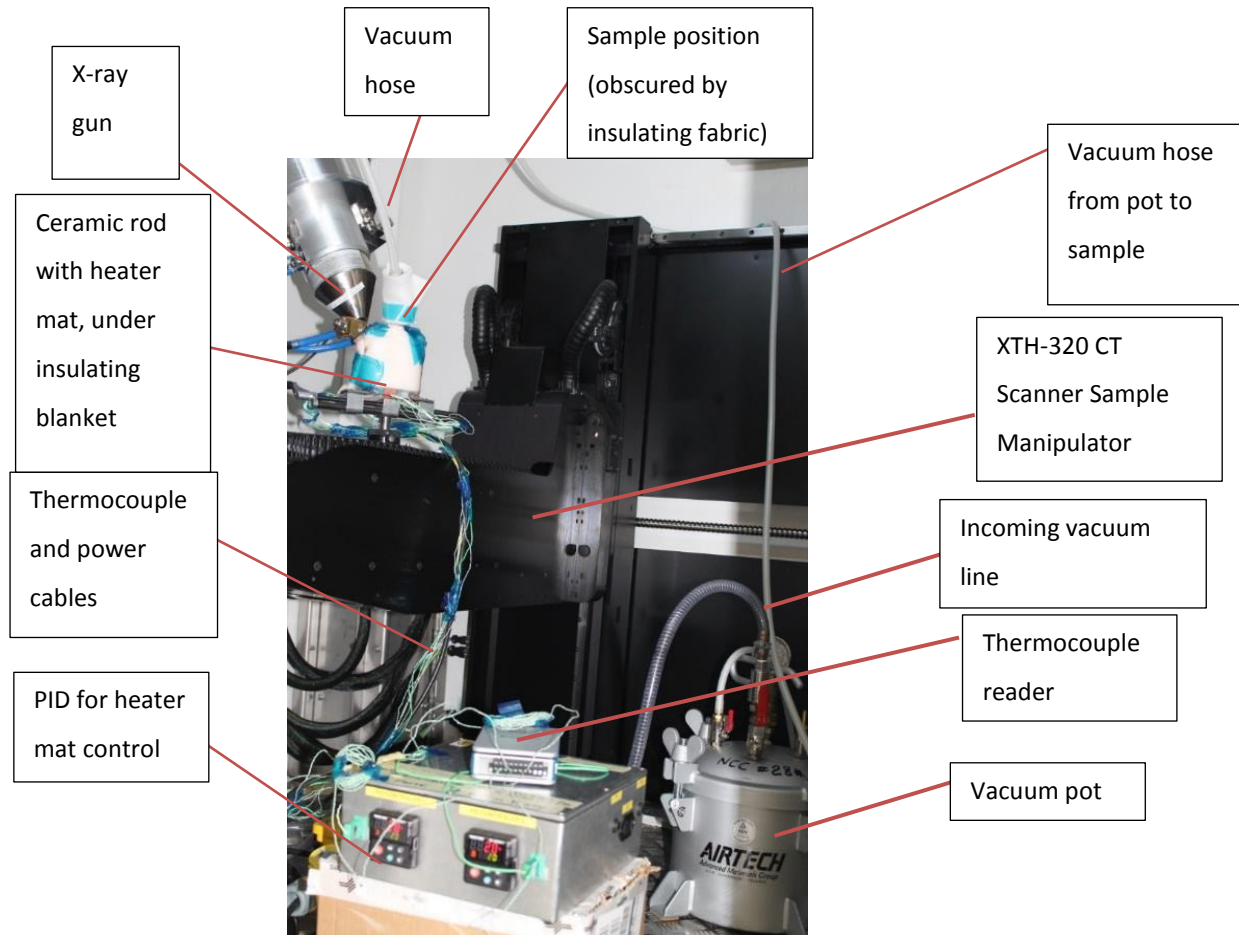

Figure 4.10: Experimental equipment in XTH-320 CT scanner cabinet

A vacuum line passes into the cabinet from outside and is connected to a pressure pot, which keeps the vacuum even in the event of fluctuations on the line. A hose from the pressure pot then runs up to the ceiling and is affixed by tape, hanging loosely down to meet the sample. This keeps the sample under an even vacuum without requiring a metal fixing (which would scatter the X-rays and cause noise) in the X-ray zone.

Both the vacuum hose and the cables connecting the heater mat to the PID and thermocouple reader must be arranged in a manner which allows the sample to rotate 360 degrees. The software is set to then counter-rotate it back to the start position before the next scan, so that the hoses and cables do not become overly tangled. They must be affixed to the cabinet and manipulator in a manner that keeps them out of the line between the X-ray gun and detector.



The 225KeV reflection X-ray head was used. While it may be possible to achieve better results using a rotating target head- allowing higher power to be used- the time required to swap the heads for each day on a shared use machine made this impractical.

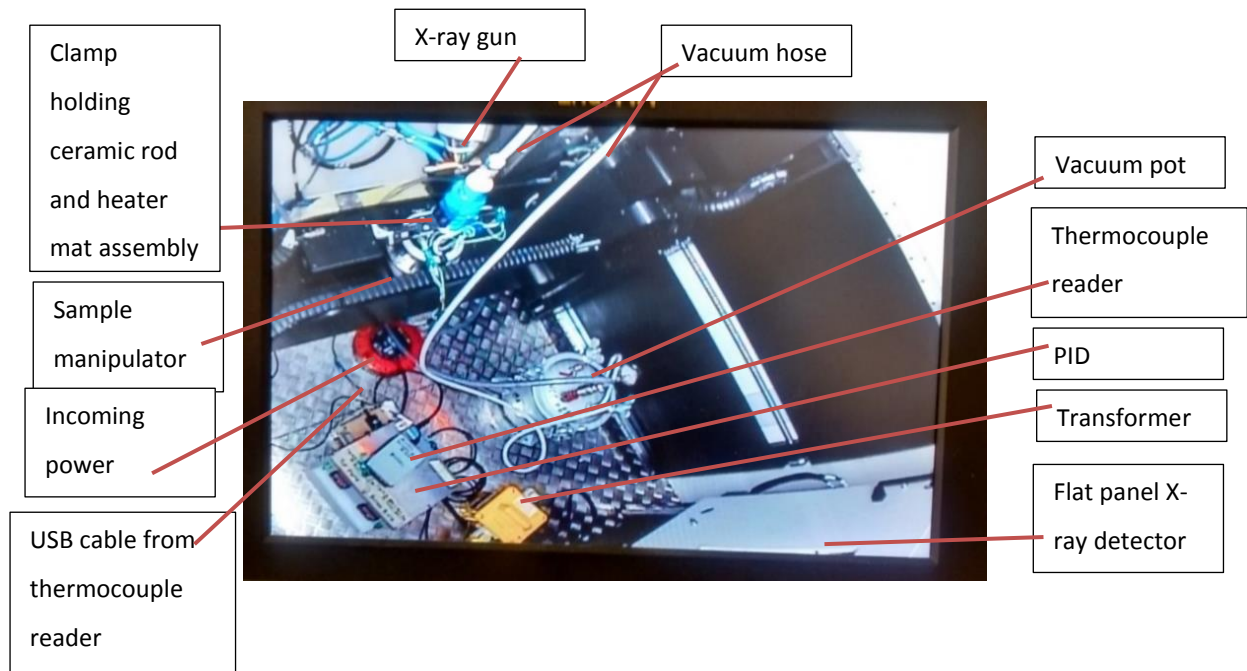

Figure 4.11: Experimental setup viewed from above

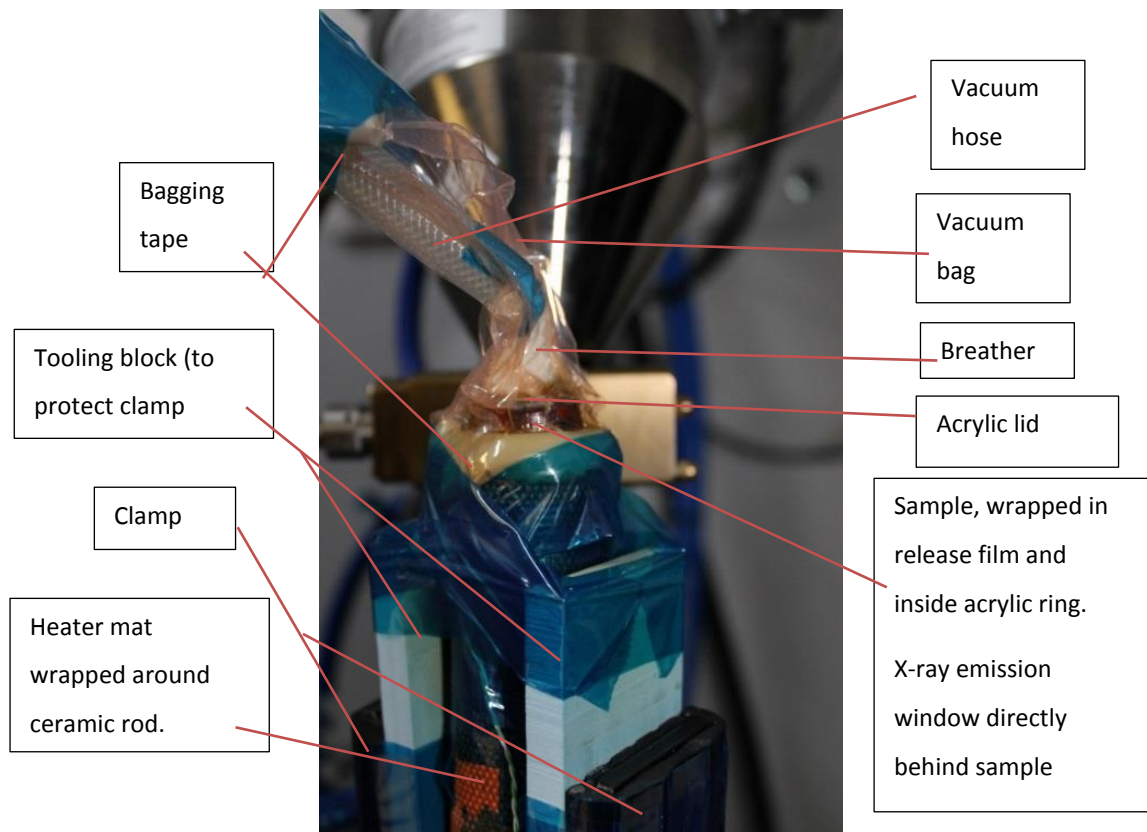

Figure 4.12: Close-up view of bagged sample, in position for curing.

## 4.5 Sample Geometries

Each sample consisted of 22 plies of M21 carbon fibre or glass fibre prepreg. The sample was cylindrical, for maximum scanning efficiency, and approximately the size of a pound coin, having a 20mm diameter. The small size allowed the sample to be positioned physically close to the X-ray gun, achieving a resolution of 13.45  $\mu\text{m}$ .

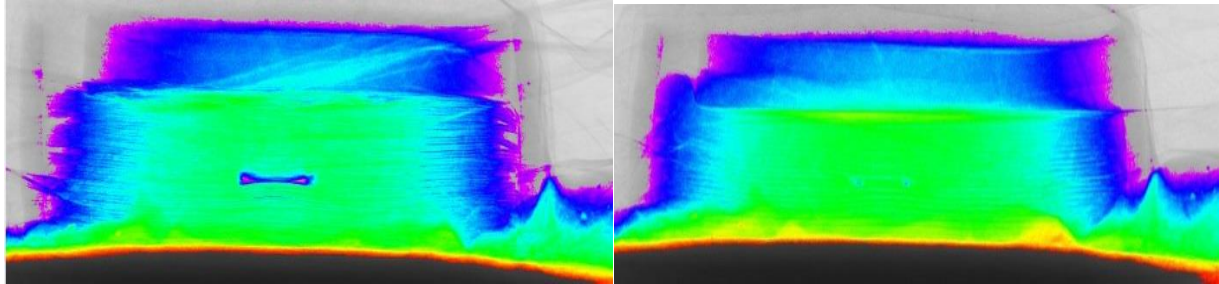

Figure 4.13: Scatter free radiographs of sample before (left) and after (right) cure. False colour, with shading correction. Looking end-on at the gap. The black is the ceramic rod and the material to the side and in front of the sample is bagging tape. The acrylic lid is in a bluer colour above. The sides of the acrylic ring and the bag can be seen in grey.

### 4.5.1 Tow Gap

The unidirectional carbon fibre was laid up in a balanced manner  $[0,90\dots0,0\dots90,0]$ . Each of the two central, 0 degree plies was created from two truncated semicircles, cut along the fibre direction with a gap of approximately 2mm between them. Figure 4.13 shows an example.

This is intended to be representative of an AFP-type tow gap. We expect to see some lateral movement of fibres into the gap along with resin flow. (Figure 4.14)

### 4.5.2 Ply Drop

The unidirectional carbon fibre was laid up in one direction (90) only. Each of the two central plies was created from two truncated semicircles, cut across the fibre direction, laid up with a gap of approximately 2mm between them. As the gap is cut across the fibres, here we expect to see lateral movement of resin only, though the plies above and below the gap may bend .

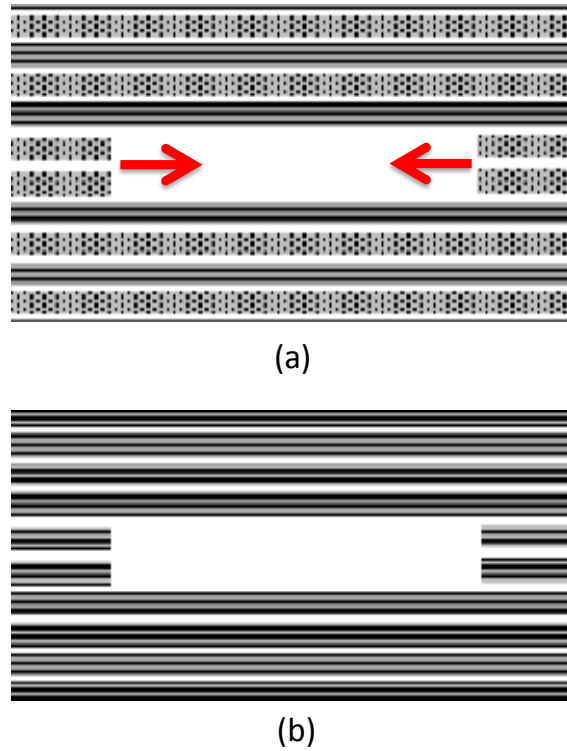

Figure 4.14: Tow gap (a) and Ply drop (b) sample lay-up near the central gaps. (a) shows [0,90] symmetrical layup, with two 0 degree plies in the centre, with the gap in the fibre direction. (b) shows all 90 layup, with the gap across the fibre direction. Arrows mark the expected direction of lateral fibre movement in the tow gap case. The ply drop sample will show if resin movement is sufficient to fill the gap.

#### 4.5.3 Glass fibre-M21 sample

Woven glass fabric was laid up in one direction only. Each of the two central plies was two truncated semicircles, laid up with a gap of approximately 2mm between them. These samples were used to test the analysis method with a glass fibre-epoxy composite.

## 4.6 Method

### 4.6.1 Temperature measurement baseline

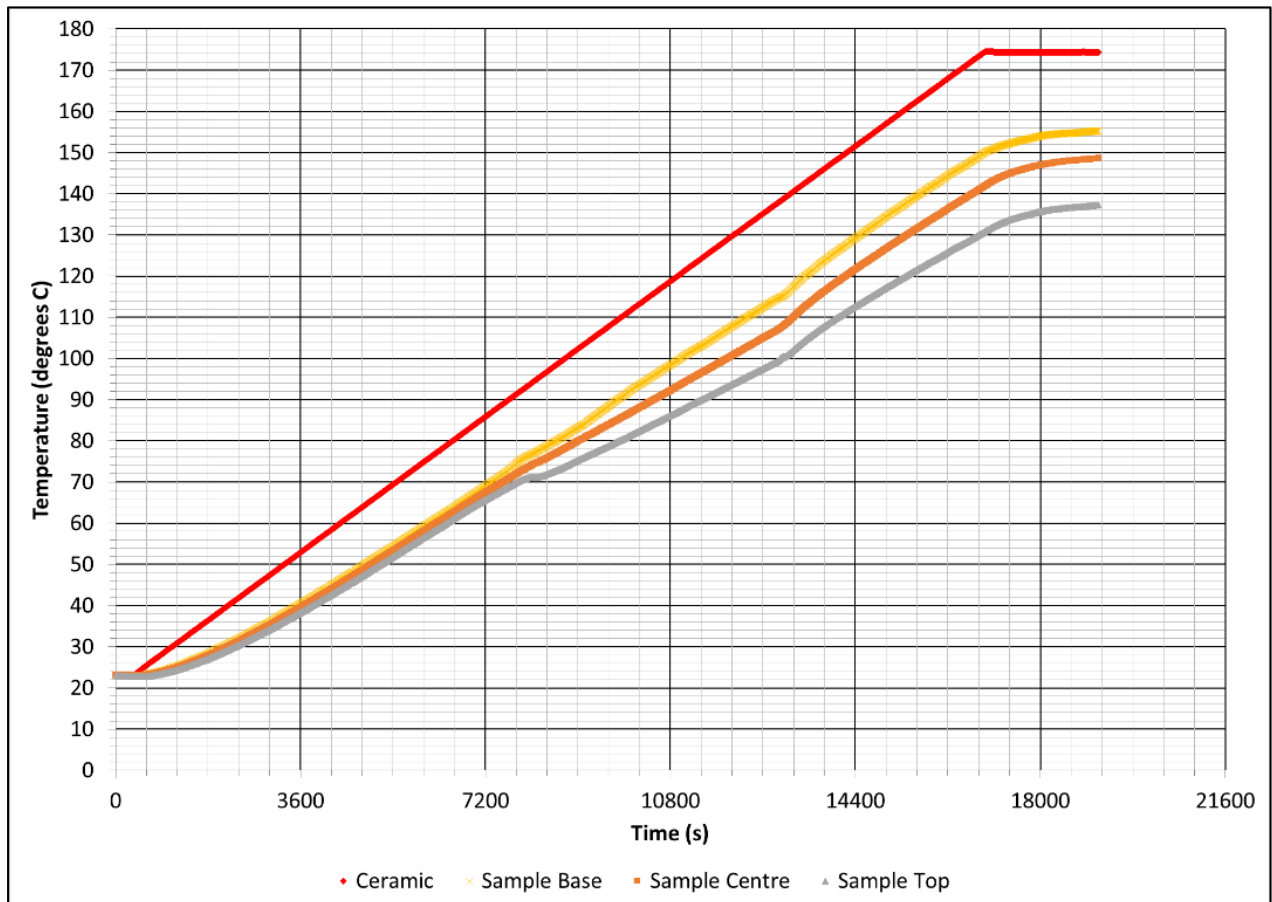

Figure 4.15: Temperature measurement baseline

Initial tests showed that scan quality was significantly improved by keeping the thermocouples, which cause X-ray scatter, away from the X-ray cone.

For this reason, the temperature of the setup is controlled and measured by thermocouples embedded in the bottom of the ceramic cylinder, well away from the x-ray zone. In order to estimate the temperature of the sample from this, a temperature calibration experiment was carried out, with the result shown in Figure 4.15.

Thermocouples were placed in the base of the ceramic rod, between the top of the ceramic rod and the sample, embedded in the middle of the sample, and on top of the sample. No scans were taken, but otherwise the same setup was used as during an In-Process XCT batch scan. The results of this were used to estimate the sample temperature based on the measured base ceramic temperature during the experiments in the scanner cabinet.

#### 4.6.2 X-ray CT settings

The fastest scan attempted with the XTH-320, using the 225KeV reflection head, took just under 4 minutes. Achieving such a fast scan meant using a low number of projections and very short exposure. It is possible to identify the deliberate, large gap using this setting, but the scans were- unsurprisingly- very noisy. A scan of just under 7 minutes showed significant improvement in the quality of the results without any blurring from geometrical changes during that time. This scan was 1600 projections with a single frame per projection and an exposure of 250ms per frame. A resolution of 13.45 microns or higher was found to be suitable, being enough magnification to clearly identify the voids while allowing a power of 13W to be used (which results in a focal spot size of approximately 13 microns, just smaller than the required resolution). A higher power means a greater X-ray flux, making the most of a short exposure time. The X-ray energy was set to 180KeV. For each sample, the position and settings were checked and a shading correction taken. A batch program started a scan every 10 minutes for a total of 45 scans (7 hours and 20 minutes) as the cure proceeded. This timing was sufficient to see each successful run to gelation and allowed two runs to be done per day, with the second left on overnight.

Each scan was automatically reconstructed using CT pro software. The best results were achieved using a noise reduction filter on level 2. The voids and ply drops were then analysed using VG Studio Max 2.2.

#### 4.6.3 Void analysis

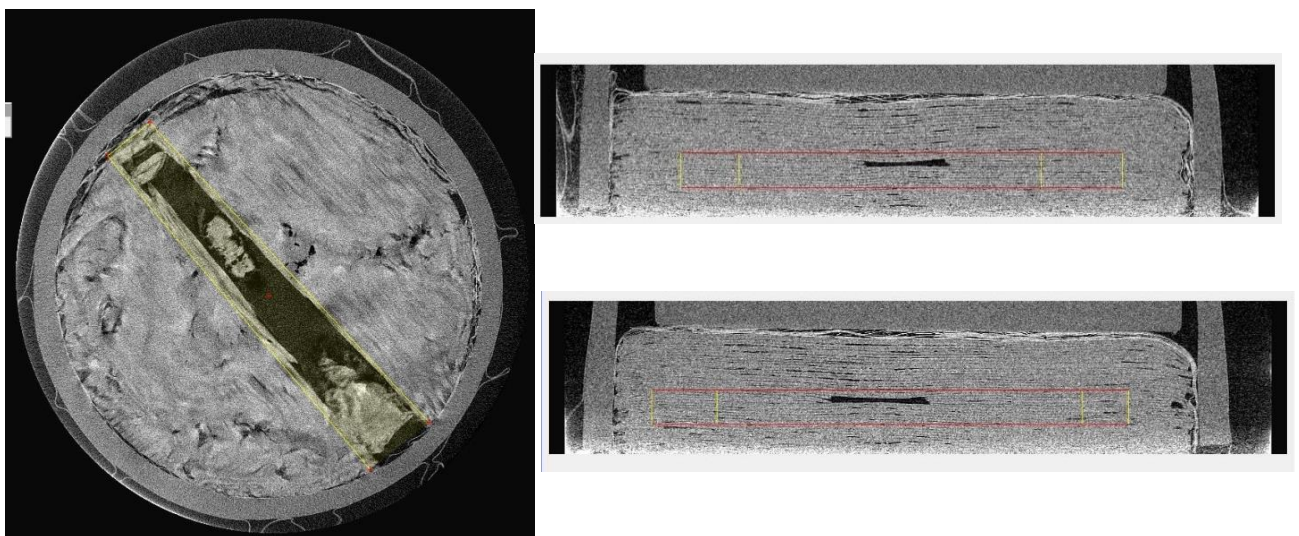

Figure 4.16: Drawing the region of interest on the 3D reconstruction of the first scan of a tow gap sample. The same region of interest is used on each reconstruction. Space is allowed below the gap as the sample will shrink vertically as it consolidates.



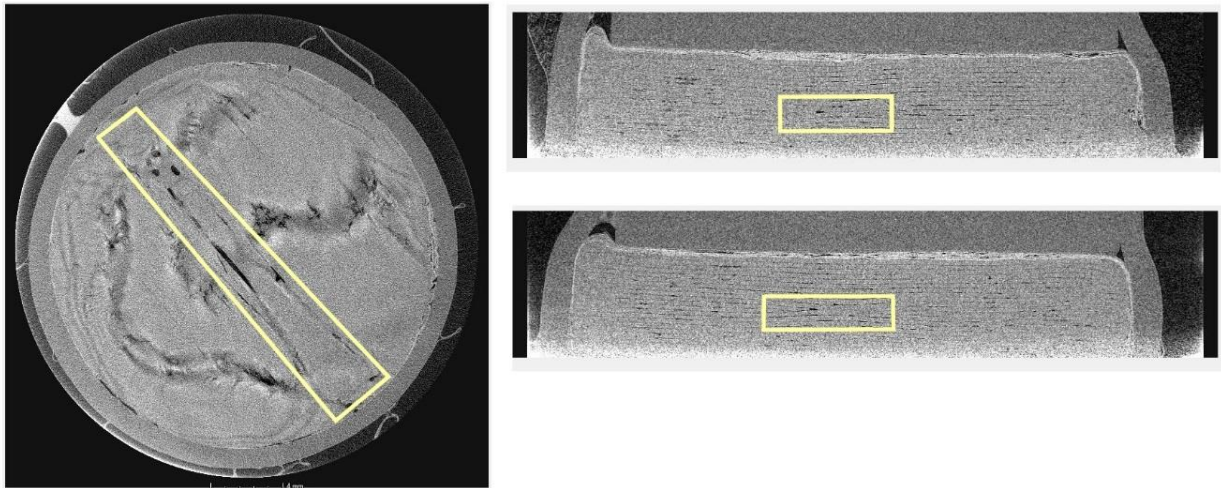

Figure 4.17: Applying region of interest to 3D reconstruction of the last scan. The gap is still within the region.

A region of interest is defined for the void analysis, containing the main gap, as shown in Figure 4.16 and Figure 4.17. This is deliberately placed where voids are expected to be at a maximum. As the sample consolidates and changes the gap position relative to the scan baseline moves, so the region must be large enough to allow for this. Hence, while any smaller voids and gaps in the region of interest will also be detected, the volume and geometry over which the voids are measured is constant throughout and dominated by the deliberately introduced gap. All voids in this region are measured as, at later stages, it is difficult to tell which of the smaller voids were initially part of the large one.

After defining the region of interest and saving it as a template, a macro was created to automate application of the void analysis process to all 45 reconstructions. The steps in the process can be seen in the appendix. The macro applies a median filter to smooth greyscale values over 5 voxels, which helps to remove noise and is at too small a scale to affect the void sizes measured. Voids are measured only in the region of interest, as shown in Figure 4.16 and Figure 4.17, to prevent the sample edges being erroneously detected as voids.

VG studio's built in ISO-50% surface determination routine was used to find the boundaries between resin and air in the region of interest of the 3D reconstruction. This uses the grey levels in pixels to define a boundary between two materials. Surface determination is discussed in Chapter 2. Voids of volume 0.01 to 100mm<sup>3</sup> are measured, hence ignoring anything too small to be reliably identified as a void and any spuriously large measurements. Figure 4.18 shows an example.

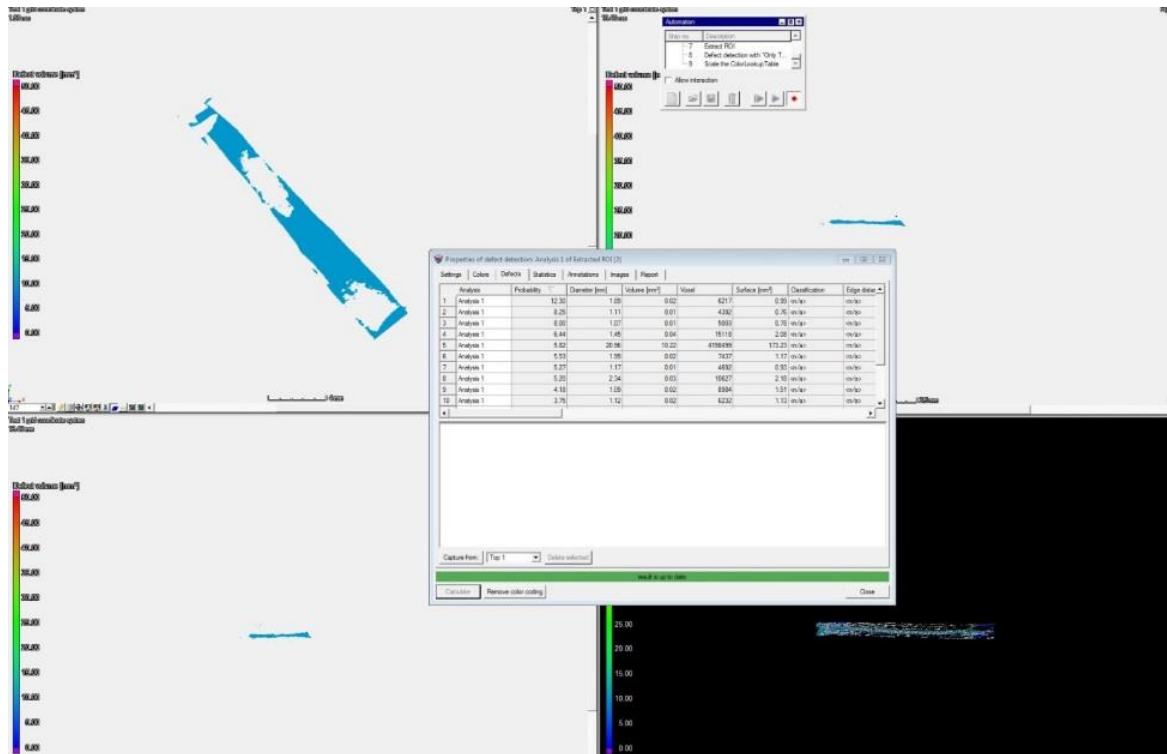

Figure 4.18: Identifying voids using VG studio max, for the reconstruction shown in Figure 4.16. Extracted void volumes in the region of interest are shown in blue, along each axis and in a 3D representation (black panel), behind a table listing the voids.

## 4.7 Results

### 4.7.1 Tow Gap

Results for tow gap samples, including two full length batch runs and two truncated runs (due to failures of the filament in the CT scanner) are shown in Figure 4.19. It should be noted that there is a missing scan in the shortest truncated run (palest blue), due to data transfer problems.

The starting void volume varies as each sample analysis is manually laid up. It can clearly be seen that the void volumes decrease as the resin begins to flow and the sample consolidates, becoming small or disappearing below the limit of detection. Voids are then seen to grow later in the cure.

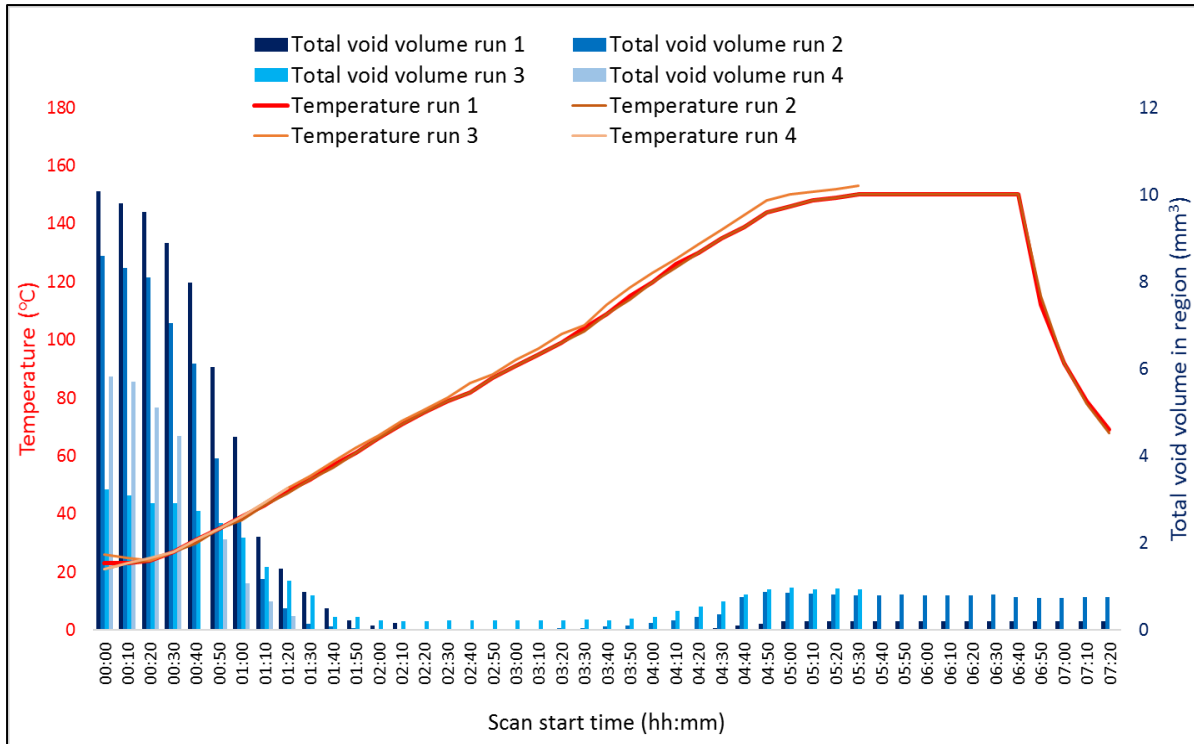

Figure 4.19: Tow gap void evolution during cure. Blue bars are total void volume within the region of interest (different shade for each run), red/orange lines show temperature, estimated according to section 4.6.1

Figure 4.20 shows images of the void evolution for tow gap run 1, shown in the darkest colour in Figure 4.19. These are slices through a 3D volume reconstructed from the CT scan. The images on the left are slices partway through the vertical height of the sample, always at the same position (slice 143). As the sample consolidates and shrinks vertically, different layers move through this slice.

The images on the right are slices halfway through the x axis of the sample. Note that the gap does not run directly along an axis. The consolidation of the sample as a whole can clearly be seen, along with the filling of the gap.



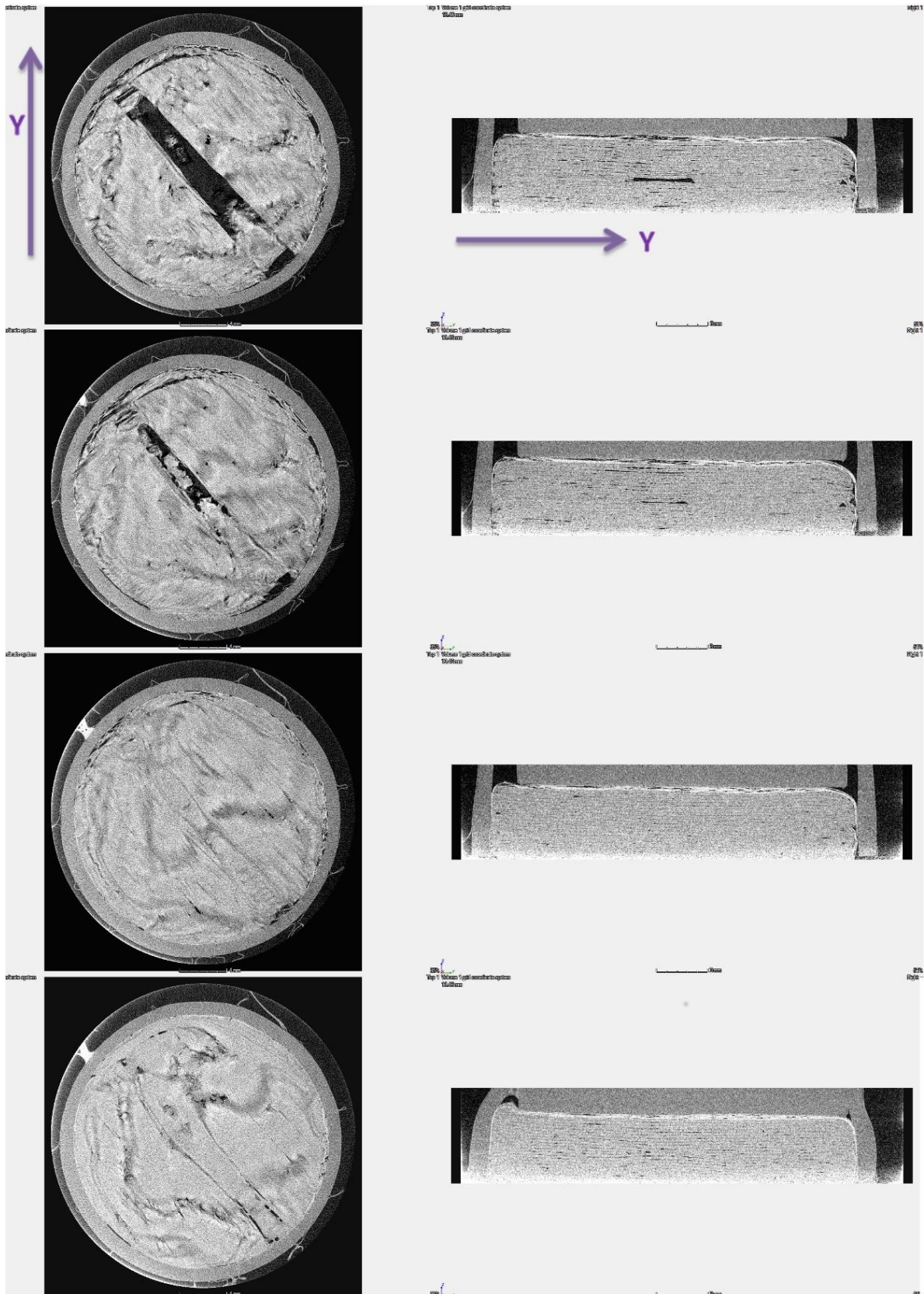

Figure 4.20: Slices through scans of a tow gap sample shown at the start (23 degrees C), 1 hour (39 degrees C), 2 hours (66 degrees C) and the end of the cure: 7 hours 20 minutes, cooled to 69 degrees C. Note that while voids are no longer visible in the 3rd picture, new voids have formed in the final scan of the batch.

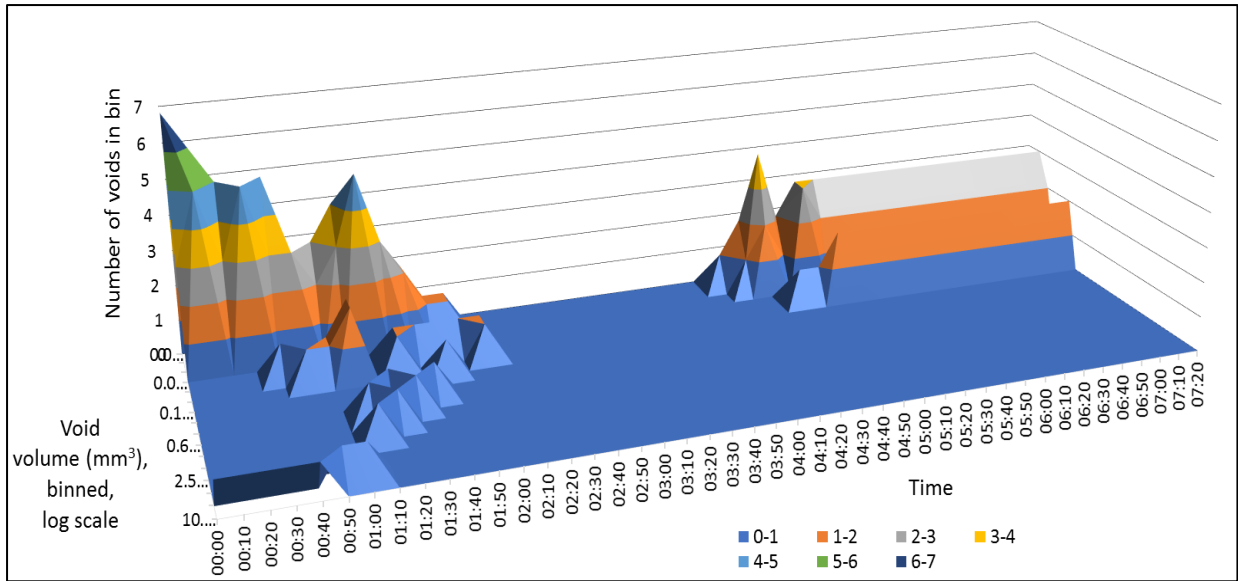

Figure 4.21: Distribution of void volumes for first tow gap run.

Figure 4.21 shows the evolution of the voids in the region of interest for the same run shown in Figure 4.20. The voids are binned by volume on a logarithmic scale. The single large, deliberate void is seen at the start, along with smaller voids. As the run progresses, the voids shrink and the large void splits into smaller voids, before all vanish below the threshold ( $0.01 \text{ mm}^3$ ) in the middle of the run. The small voids at the edges of the original gap then appear and stabilise.

#### 4.7.1.1 Comparison to theoretical resin behaviour

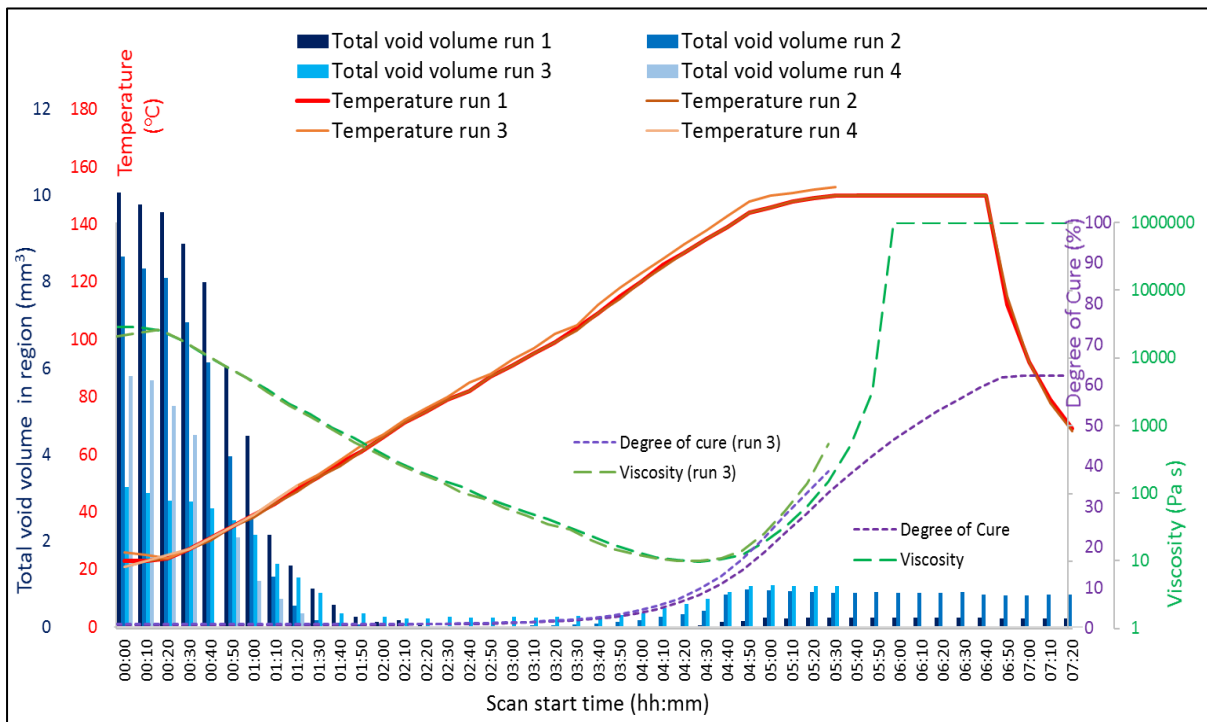

Figure 4.22: Comparison of tow gap void evolution with M21 resin behaviour. Resin behaviour calculated from the model of Kratz et al. [43]

Figure 4.22 demonstrates that the relatively small voids which grow after the sample has consolidated do so around the region of minimum resin viscosity.

The void growth model of de Parscau du Plessix et al [160], referred to in Chapter 2's literature review, models the evolution of a small, spherical bubble of vapour in an infinite incompressible, homogenous Newtonian fluid. This is not applicable at the early stage of the cure, where a large void is present, the test sample is compressed under vacuum and lateral fibre movement into the large void is expected. However, it may be relevant to the evolution of small voids which remain after the large void is mostly filled.

The model predicts an increase in void radius as resin viscosity decreases and temperature increases, caused by increase in bubble pressure from both the change in temperature and, if moisture is present, diffusion of water molecules into the bubble. which would fit with these results. Their experiment did not see "significant growth of voids without prior exposure to humidity" as air was evacuated during a debulking stage, which was not the case here. The samples were not exposed to moisture, however trapped air and volatiles were present. These voids appear to stabilise upon gelation, which should be expected.

Similar results were not seen by Centea and Hubert [27] or Serrano [28] in their studies of porosity of multiple quenched samples. These works, also discussed in Chapter 2, measured percentage porosity rather than evolution of a specific defect. As there is unavoidable variation between multiple samples, and the frequency of measurements in the aforementioned works is lower than that used here, it is possible that this effect may have been present without being measurable in their experiments.

#### 4.7.2 Ply Drop

Similarly to the tow gap samples, resin flows into the gap- but here the void does not appear to (almost) completely fill with resin. This is seen in all four of the samples presented, despite variation in the starting void volume and in the cure cycle.

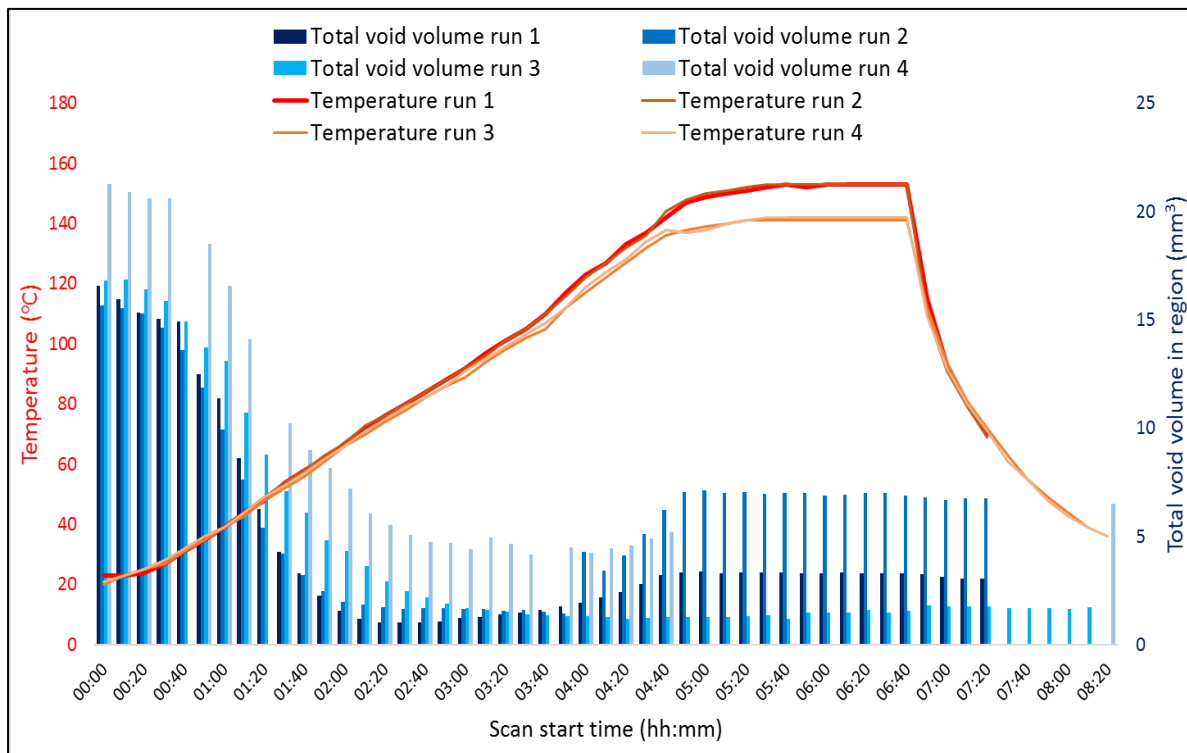

Figure 4.23: Ply drop void evolution during cure. Blue bars are total void volume within the region of interest (different shade for each run), red/orange lines show temperature, estimated according to section 4.6.1. Two different temperature cure cycles are shown.

For the ply drop gap, two slightly different cure cycles were used. The two higher temperature runs follow approximately the same as the cure profile used for the tow gap samples. Data for two lower temperature experiments are also presented here. Note that there is a significant amount of missing data (due to network problems) in one of the lower temperature runs (palest blue colour) so the behaviour of this sample during the hold cannot be inferred. It is however sufficient for studying the early stages.

For the higher temperature experiments, we again see an increase in total void volume after a minimum is reached during the cure. The same conclusion cannot be drawn for the lower temperature experiments.

4.7.2.1 Higher temperature runs, for comparison to tow gap samples.

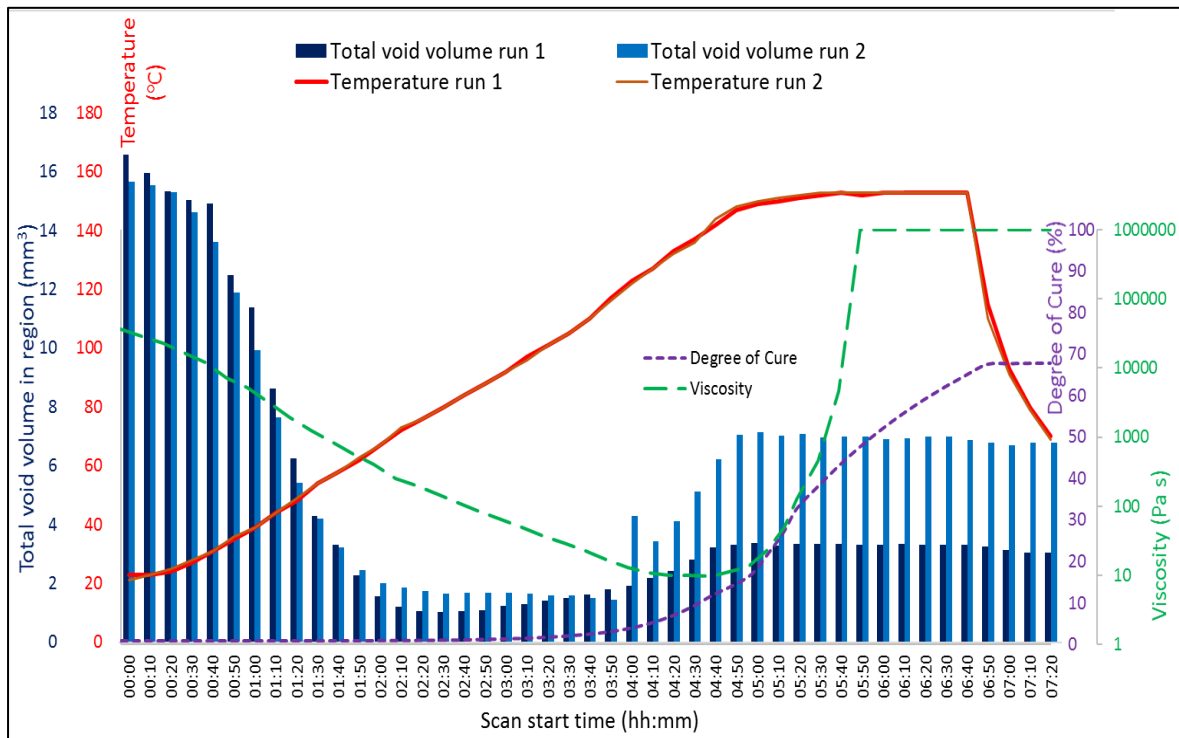

Figure 4.24: Defect evolution and resin behaviour, ply drop gap with  $\sim 150^{\circ}\text{C}$  hold. Resin behaviour calculated from the model of Kratz et al. [43]

A very similar pattern to the tow gap results (Figure 4.19) is seen in the void volumes, decreasing to a minimum then undergoing an increase at minimum resin viscosity, before stabilising at gelation. However, the void volumes are larger throughout.

The slight jump in the second run total void volume at 4 hours may be due to noise- if a scan is notably brighter or darker this may affect the surface determination level. The surface determination routine finds the boundary between resin and air, hence the edge of the void- so a slight change in the detected level could will change the void measurements.

#### 4.7.2.2 Lower temperature runs- gelation during cool down.

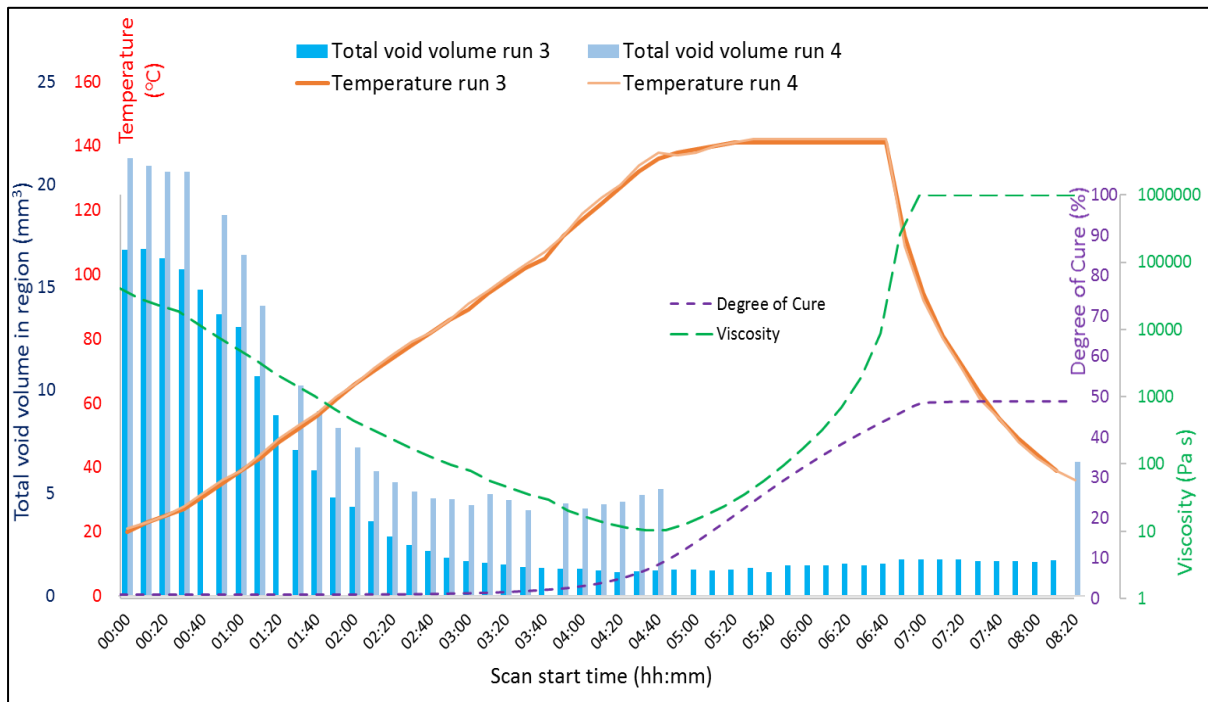

Figure 4.25: Defect evolution and resin behaviour, ply drop gap with hold at  $\sim 140^{\circ}\text{C}$ . Resin behaviour calculated from the model of Kratz et al. [43]

Data presented in Figure 4.25 shows two (perhaps 1 and a half is more accurate) ply drop defect samples cured at a slightly lower temperature. The more complete run 3 does not show a clear increase in void volume at minimum resin viscosity as the higher temperature and tow gap runs do, and there is insufficient data to draw a conclusion from the incomplete run 4. Resin viscosity still reaches a minimum at around 4h40m, as in the higher temperature runs- but gelation occurs during the cooldown phase.

#### 4.7.3 Glass fibre samples

Glass fibres can be visually distinguished from epoxy resin easily in the XCT reconstruction, as shown in Figure 4.3. However, this also has a problematic effect. Void analysis for these samples proved difficult, as the surface determination routine could not reliably identify the resin-air interface, often selecting the glass fibre-resin interface instead. This could be adjusted manually to select the correct interface, but could not be automated using the software available. While it is possible to carry out the analysis manually, the volume of data involved made this impractical. Other surface determination algorithms may solve this problem, but were not available at the time.

#### 4.7.4 Comparing start, minimum and end total void volumes

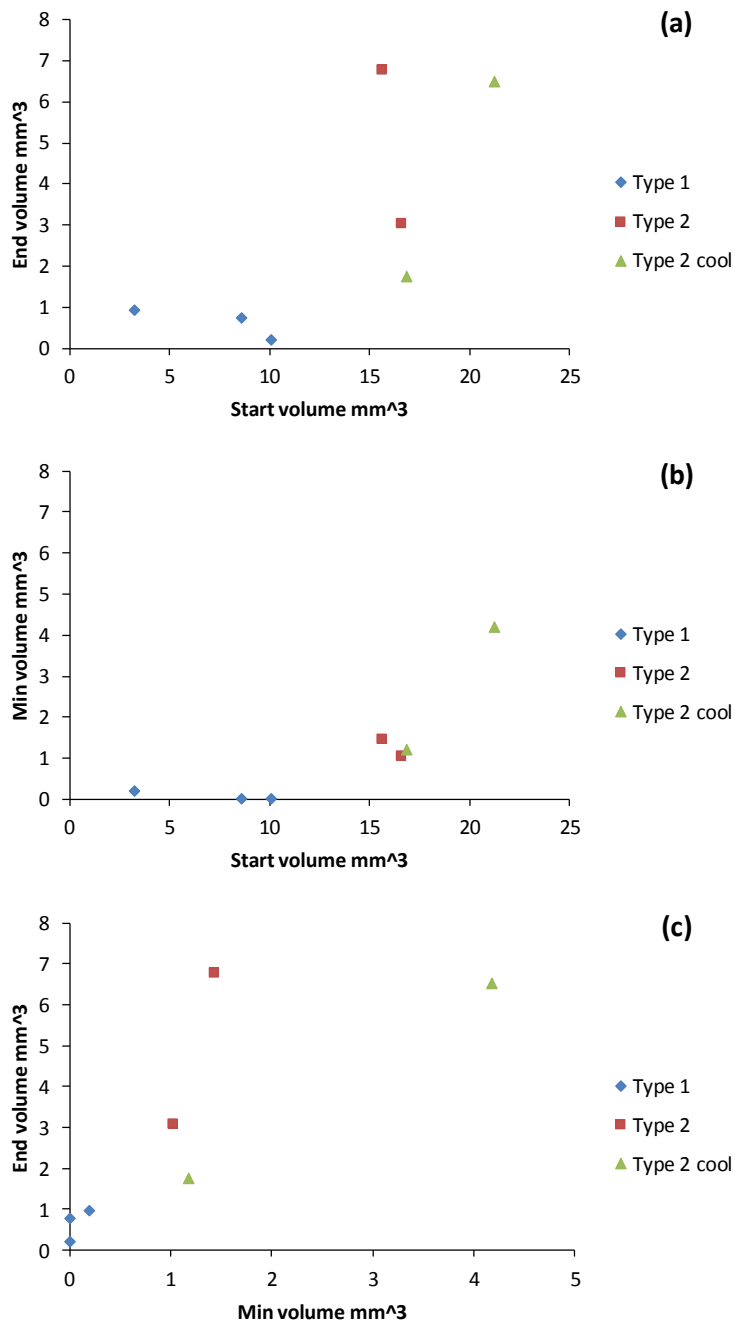

Figure 4.26: Lack of correlation between (a) start and end void volumes, (b) start and minimum void volumes, and (c) minimum and end void volumes in the region of interest. Type 1 is a tow gap, type 2 a ply drop.

There is significant variation in initial void volumes due to inconsistencies in hand layup. However, there does not appear to be any correlation between this and either the minimum void volume or the final void volume, as shown in Figure 4.26. Ply drop voids show a larger volume throughout the processing cycle than tow gap voids, but no other conclusions can be drawn from this.



#### 4.7.5 Lateral fibre movement: Comparison of Tow Gap and Ply Drop defect evolution

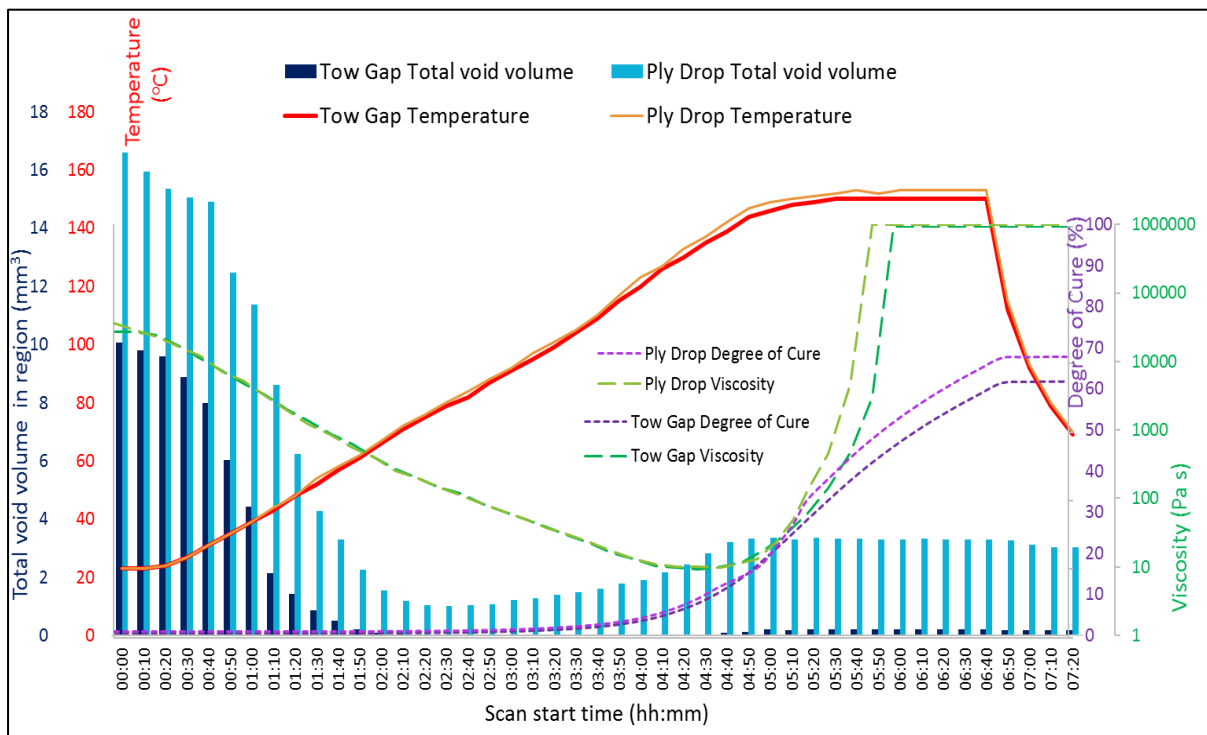

Figure 4.27: Comparison of tow gap and ply drop defect evolution. Resin behaviour calculated from the model of Kratz et al. [43] Tow gap run 1 and ply drop run 1 are shown, as these are closest in hold temperature.

While both defect types are laid up in the same manner, the volume of the defect thus created (and hence the total void volume) in the ply drop sample, where all plies are laid up in the same direction, is larger at the start than that in the [0,90] tow gap sample. This is due to the nature of the defect, as the tow gap runs along the fibre direction in the latter case, and the gap is perpendicular to the fibre direction for the former. It is possible that some lateral fibre movement into the gap might occur before the experiment, during layup or initial debulk- when first connected to the vacuum at room temperature- in the tow gap case.

The tow gap samples varied significantly in starting defect volume, but there does not seem to be a correlation between the starting total void volume and the minimum reached during the cure, or the final total void volume- though the sample size is far too small to state this unequivocally. Likewise for the ply drop samples, while all have a greater total void volume throughout than the tow gap samples, there is no obvious relationship between starting and final volumes, shown in Figure 4.26.

The lack of correlation between start and final volumes and the reasonable expectation that in a tow gap sample, fibres are likely to move laterally into the gap whereas this cannot happen in a ply drop sample, suggests that the difference in geometry is probably due to the fibre movement- both in itself and in any effect it might have on the resin movement.



#### 4.7.5.1 Microscopy

The results can be compared with microscopy images of the samples taken after cure. Due to the limitations of fast scanning, required for In-Process XCT, and of geometric magnification, it is impossible to distinguish carbon fibres from resin in the scan images from the experiments.

However, microscopy images of the cured samples allow the fibres to be seen.

A selection of samples were therefore sectioned and images taken at 10x magnification using an optical microscope. The cut has not been made parallel with the 0 degree or 90 degree fibre direction in order to avoid fibre losses from the cut area.

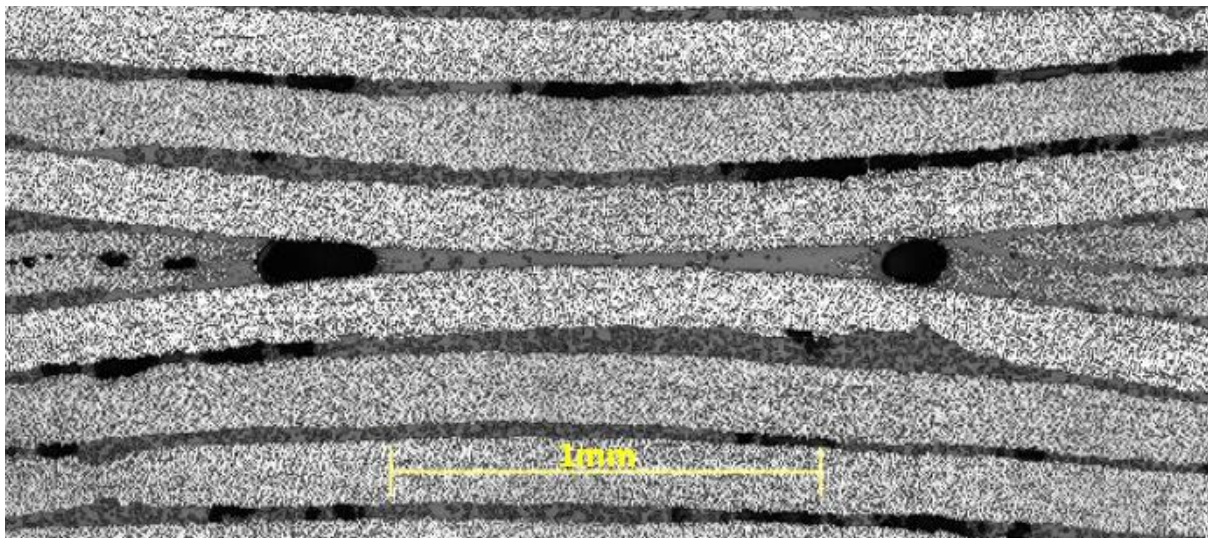

Figure 4.28: Microscopy image of tow gap sample after cure. Magnified cross section through deliberate defect zone only.

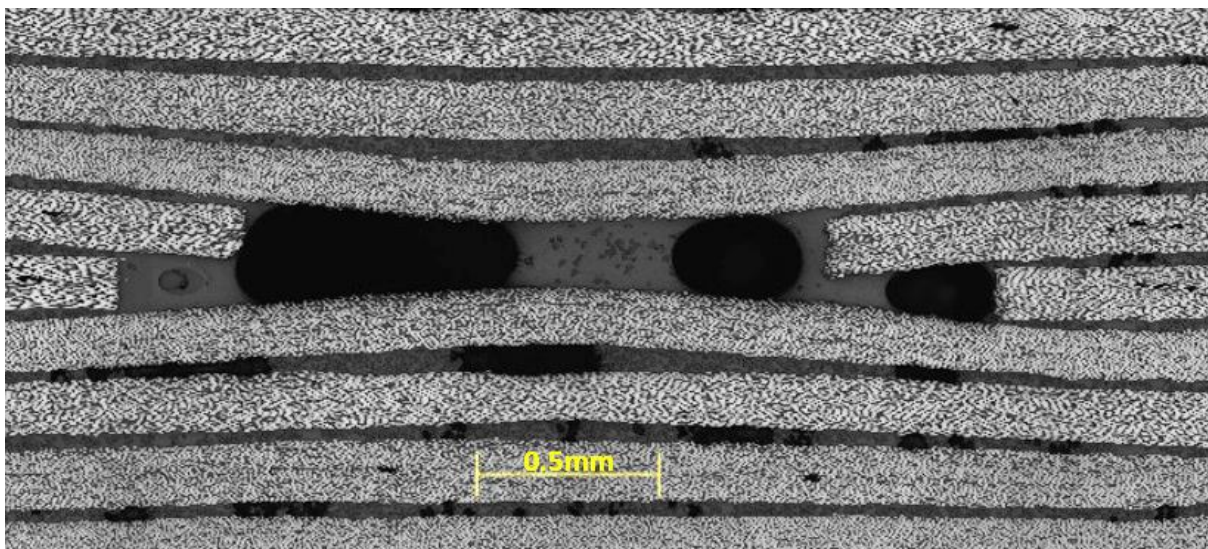

Figure 4.29: Microscopy image of ply drop sample after cure. Magnified cross section through deliberate defect zone only.

Comparing the two images, the fibres in the tow gap sample do appear to have moved laterally, while, as expected there is no visible lateral fibre movement in the ply drop sample, which has much larger voids and defined ply edges. The small dots in the resin, such as can be seen between the two large voids in the ply drop image, are toughening particles, a component of the M21 resin. The microscopy images support the In-Process XCT results, in that they show larger voids in the ply drop sample, but clear voids are present in both, in the area of the original defect.

#### 4.8 Conclusions and future work

In-Process Micro-XCT has the potential to provide detailed information on the behaviour of composites during cure than has not been available prior to today. This work provides both proof of the principle, as an experimental method, and shows detailed results measuring the evolution of features during the cure of M21 prepreg.

The results show that the void from a 2mm wide AFP tow gap will almost disappear as the sample heats up and consolidates, but from both the results and the microscopy images one sees that smaller voids remain along the line of the original gap. Significantly larger voids remain for the ply drop gap, across the fibre direction, showing that resin flow alone is not sufficient to close over this particular defect.

The post-minimum voids grow at a time consistent with the minimum viscosity of the resin. This appears qualitatively consistent with the void growth model of de Parscau du Plessix et al [160], which predicts an increase in void radius as resin viscosity decreases and temperature increases. It would be interesting to develop an X-ray transparent pressure chamber so that samples could be cured under pressure rather than relying solely on vacuum- this may affect the formation of the secondary gaps seen here.

Centea and Hubert [27] and Serrano [28] do not see this increase in porosity in their studies using multiple quenched samples. The former, studying debulk, may perhaps not reach a sufficient temperature, though for efficient debulk one would expect minimum viscosity to be the aim. As the latter follows the manufacturer's recommended cure cycle for their resin, one would certainly expect sufficient temperature to be reached there. It is possible that the out of autoclave resin used by Serrano does not behave in a similar manner to M21- but given the variation between samples in this work, it is also possible that this effect was missed due to variation between Serrano's multiple samples or the relatively few samples taken, compared to the number of data points during this cure. This demonstrates the value of following a single sample through the cure process.

The XCT Scanning results could potentially be improved by use of a rotating target head. A different experiment may allow longer scans- or require shorter ones- and the general trade-off of noise levels versus scan time must be considered when using this method. Detector pixel binning, which was impractical to implement for this work, may deliver better results, as used by Keyes et al [149] and Plank et al [150]. An industrial CT scanner has clear benefits in terms of cost and availability when compared to a synchrotron and the resulting scans were of sufficient quality for this work- but the technique could be used on a beamline if faster scans or higher flux were required.

The immediate next steps are somewhat simpler. This work has demonstrated the concept, using a small sample and a somewhat ad-hoc experimental setup which applies heat and vacuum sufficient to cure the composite without damaging the CT Scanner. An X-ray transparent pressure chamber, with more powerful heating options, would allow more realistic cure cycles to be studied. A different CT scanner- such as a larger chamber, allowing greater geometric magnification- or a medical-style scanner where the source and target rotate while the sample remains still- might deliver sufficient magnification to extend this study to larger objects.

The method of In-Process XCT Scanning could be applied to many other problems in composite manufacture, such as consolidation in a corner or tracking the effects of foreign bodies laid up into the laminate. As a proof of concept we consider this a success, and only the start of a potentially very interesting area of research.

# Chapter 5

## 5 Cure Cycle Optimisation and Control with Dielectric Monitoring

### 5.1 Abstract

In the manufacture of advanced composite parts, it is common practise to follow a cure cycle recommended by the resin manufacturer. Depending on the requirements for the part(s) under cure, this may not always be the most efficient option. An autoclave or oven running longer or hotter than necessary leads to costs both financial and ecological for a business. As demand for composite parts increases it is necessary to become ever more efficient in our manufacturing.

A bespoke autoclave has been instrumented with two different cure monitoring systems. These have been used to track the cure of a varying thickness test part over a variety of different cure cycles, seeking to optimise for energy usage while achieving the desired degree of cure.

The two systems are compared to each other, to simulation using a commercial software offering and to laboratory measurements of the final degree of cure and glass transition temperature using samples from the cured test parts.

Energy usage has been directly monitored and both costs and equivalent CO<sub>2</sub> emissions are estimated for each cure cycle.

Finally, feedback from one of the sensor systems was used to control the cure cycle, moving the autoclave to the cooldown phase as soon as the desired degree of cure was reached in the thickest and thinnest extremes of the part.

### 5.2 Introduction

Autoclaves and ovens remain very popular for manufacturing of composite parts. It is immediately obvious that such energy intensive equipment should be used as efficiently as possible, to minimise cost and energy usage, with all the negative implications such entails. Monitoring the degree of cure and  $T_g$  of the resin, building towards direct control of the cure based on sensor feedback, therefore has the potential to be very useful.

Theoretically optimised cure cycles can of course be developed based on simulation. Comparison of such simulation to a physical, real-time measurement may be used for model verification and to compare the behaviour of the oven or autoclave to the ideal, theoretical cure cycle. Convergent's Raven software [224] is used for simulation in two ways here, the first based on ideal cure cycles and the second, after the fact, simulating the actual cure cycles using real temperature measurements taken from thermocouples embedded into the part.

One limit of simulation is that it cannot be used for feedback during a process. Manufacturing processes often have some variability, for example due to variation between material batches, local environmental conditions or individual laminators' lay-up skills and techniques. Autoclaves are controlled based on feedback from pressure sensors and thermocouples, often embedded in the part or the tool- this work investigates the possibility of extending this to feedback based on real-time resin status measurements such as the degree of cure.

Dielectric sensors are interdigitated electrodes, placed in contact with the resin. A potential is applied across the electrodes. In a Direct Current (DC) system, the resistivity is measured. In a Dielectric Analysis system (DEA), an alternating current is applied, cycling through a range of frequencies. The response of the resin changes as the cure progresses. Using a previously validated model of the resin behaviour, degree of cure and/or glass transition temperature can be tracked, in-situ and in real time.

In order to test the suitability of such systems for cure cycle optimisation, two commercially available monitoring systems- Synthesites' Optimold DC system [225] and the Advise-DETA DEA system [34]- were integrated with a bespoke autoclave. Both systems were simultaneously used to monitor the cure of a varying thickness test part, at the thick and thin extremes. After cure, Differential Scanning Calorimetry (DSC) and Dynamic Mechanical Analysis (DMA) were used to measure the degree of cure and glass transition temperature ( $T_g$ ) respectively for samples from each test part.

The energy use of the autoclave was directly measured using an energy monitor, and used to estimate the cost and equivalent carbon dioxide emission for each cure cycle tested.

### 5.2.1 Important Advisory

This study was carried out using one part design in one relatively small autoclave. It is intended as an investigation of the potential of the technology using a representative example, not as a guarantee of achievable cost and energy savings on all composite parts. Actual savings will depend on factors including the part design, material, in-service requirements, equipment used for the cure and how the autoclave or oven is packed (e.g. all the same part or a variety of different ones?).



### 5.3 Equipment



Figure 5.1: The bespoke autoclave (2m internal diameter x 3m length) at the National Composites Centre, with pass-throughs for cure monitoring sensors. The control computer is at the front left. A test part is inside the autoclave, thermocouples attached.

A bespoke autoclave, shown in Figure 5.1, equipped with blanked off pass-through ports, was purchased by the University of Bristol with EPSRC funding. This project marks the first sensor integration and first results from what should, eventually, be a fully instrumented pressure testbed.

The autoclave, made by ASC following their 'econoclave' design [123] is of 2m internal diameter and 3m internal length and powered by electricity only, capable of a maximum of 10 bar pressure and 250°C. This is small by industrial standards but large enough for development purposes. It has 8 ports, 6 blanked-off and 2 in use for the sensor systems (Figure 5.2), and 2 observation windows.

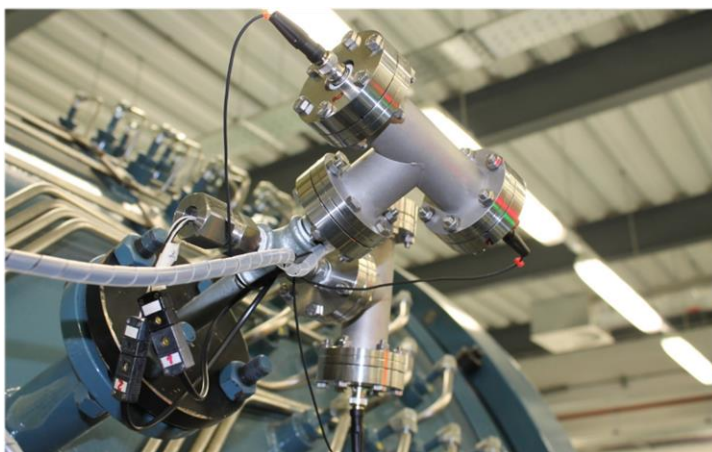

Figure 5.2: A closer view of a pass-through for the Advise dielectric cure monitoring system. Two channels, each consisting of two cables for sensor data and one thermocouple, enter the autoclave at this point, through a machined flange plate attached to a DN50 port (internal diameter 50mm) for pass-throughs.

### 5.3.1 Sensor systems

Two sensor systems were purchased, using different technology. The knowledge transfer resource in Chapter 6 refers to both systems. The theoretical background is discussed in Chapter 2.

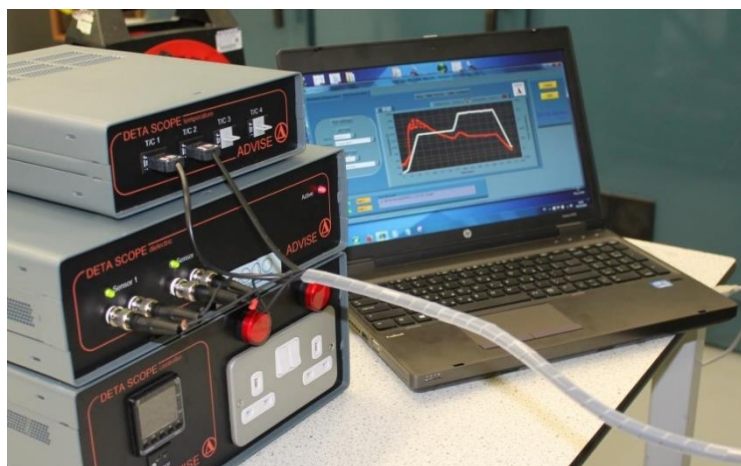

Figure 5.3: Signal processing system and control PC for the Advise DETA-Scope Dielectric Analysis system. Two channels and two thermocouples are active. The PC screen shows the monitoring software: temperature (white) and conductivity (red) from one sensor on a completed cure.

The ‘DETA-Scope’ Dielectric Analysis (DEA) sensor system, shown in Figure 5.3, was purchased from Advise [34]. This system evaluates the state of resin cure based on the electrical response to an alternating current applied to the resin by means of a small, interdigitated electrode placed in contact with the resin. The frequency of the alternating current varies over a set range- in this study from 1Hz to 100kHz- and the system outputs a measurement of conductivity along with detailed information such as the real and imaginary impedance [17] at each frequency. A built in model for a specific resin is used to calculate properties such as degree of cure,  $T_g$  and viscosity in real time.

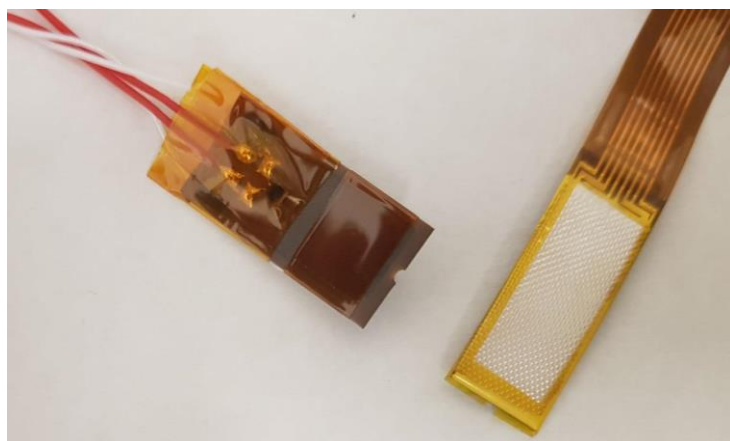

Figure 5.4: A Synthesites Optimold cure sensor (left) with a commercial Netzsch Kapton substrate electrode as used with the Advise DETA system (right). The Kapton electrode is approximately 1cm wide.



Figure 5.5: An Optimold signal processing system from Synthesites. This can be attached to a single DC cure monitoring sensor. The PC- not shown- can process signals from multiple sensors simultaneously, measuring resistance and temperature.

The 'Optimold' direct current (DC) cure sensor system, shown in Figure 5.5 was purchased from Synthesites. This system also uses an electrode in contact with the resin, but uses a direct current. The system trialed outputs only measurements of temperature and resistance, but, when the results are provided to the manufacturer, an estimate of  $T_g$  - again based on a model- is returned.

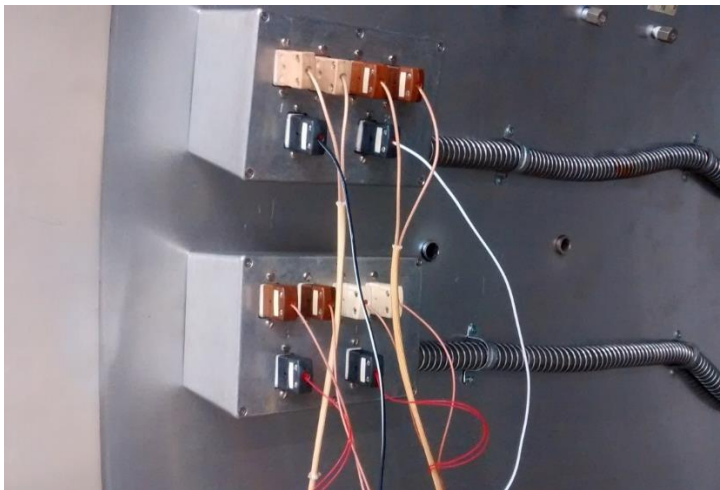

Figure 5.6: Sensor connection points inside the autoclave. Advise DETA sensors and associated thermocouples are connected on the upper two channels. The sensor connectors for the Synthesites Optimold system have been modified- at both ends- to use the lower two channels.

The two ports on the autoclave used to create pass-throughs for the sensor system, shown in Figure 5.2, were both installed by Advise, with two data channels and two type K thermocouples in each port. One of the ports was then modified for use with the Synthesites system, though it must be noted that, as the cable types do not exactly match those used by the Synthesites system the results had to be post processed with an independent temperature measurement (see section 5.7.3). The internal connections can be seen in Figure 5.6 and the combined system of autoclave plus sensor connections, with a part ready for cure, in Figure 5.7.





Figure 5.7: A test part connected up to the sensor systems (left), vacuum hoses (left top) and autoclave thermocouples (right), inside the bespoke autoclave. The autoclave has an internal diameter of 3m.

As both of these systems use proprietary cure kinetics models, their validity for the specific resin system used here is assessed by comparison to DSC and DMA measurements, carried out by the Materials Laboratory at the National Composites Centre.

Both systems were used with flexible sensors, laid up between plies in the test part. This allows the state of the material to be tracked at the sensor position, which can be anywhere in the part.

The Advise DEA system was connected to the autoclave control PC, sending degree of cure, viscosity and conductivity measurements for two channels. The autoclave software was modified by the autoclave manufacturer to facilitate this work, setting it to read the values from the DEA system as input variables, thus enabling control of the autoclave based on the DEA system.

#### 5.4 Part and Materials

The test part was intended to be representative of a real part, but simple enough that samples could easily be taken for laboratory analysis.

Real composite structures often have complex geometries and significant variations in thickness, along with inserts such as layers of foam or honeycomb. The progress of the cure will be most affected by changes in thickness, as a thicker layer may take longer to reach the desired temperature in an autoclave- but once past an activation energy, is also more likely to overheat as part of a runaway exothermic reaction ('exotherm') as the larger volume of resin contributes more energy.

A stepped wedge was therefore chosen, varying from less than 2 mm to almost 40mm in height, with simple steps as shown in the diagram, Figure 5.8 and photographs, Figure 5.9.

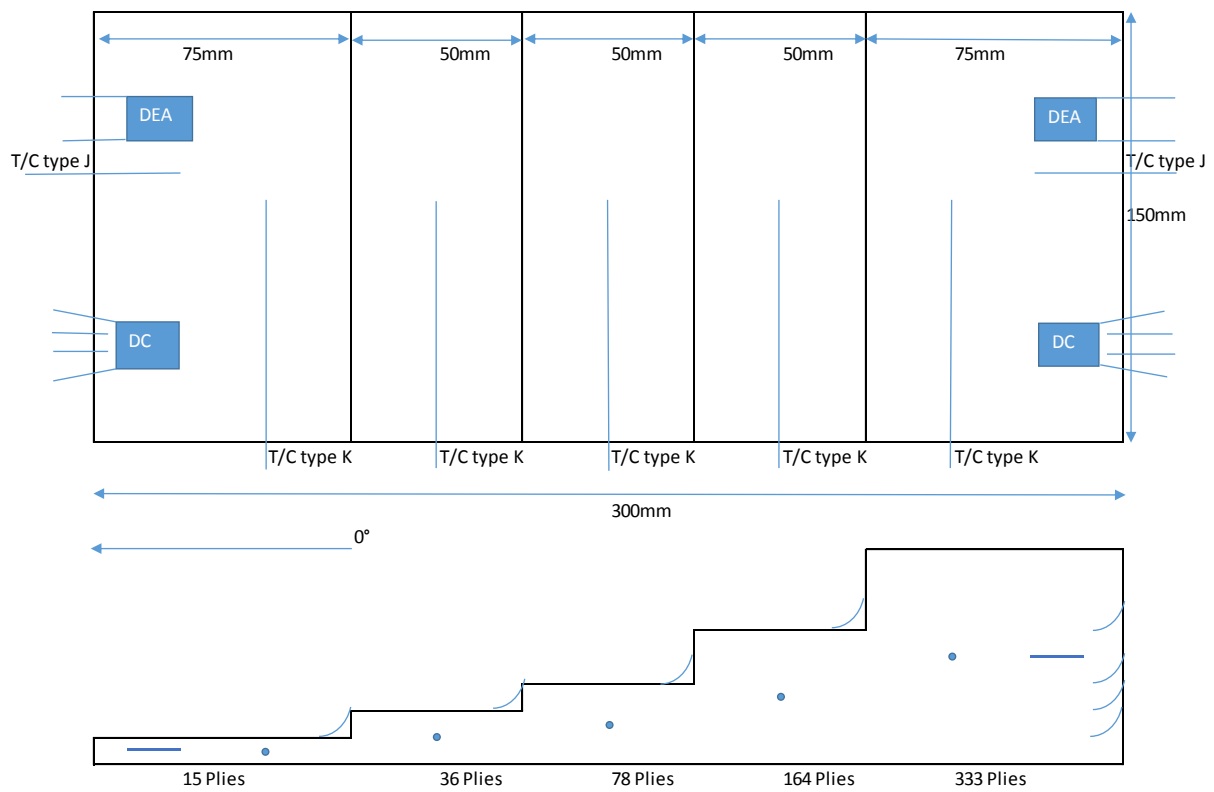

Figure 5.8: Diagram showing the planned layout for a stepped wedge. The blue curves on the side view indicate that plies should be offset slightly to avoid sharp corners at each step, as this causes bridging of the bagging materials and hence poor consolidation in corners.

Each step is wide enough to be sectioned for DSC and DMA samples, while avoiding the areas containing sensors. Dielectric and DC sensors were placed between plies halfway up the height of the thinnest and thickest steps, and thermocouples were placed in the centre of each step, halfway up the thickness. Step 1 is the thin end of the wedge, step 5 the thick end.

The part was made from unidirectional 8552 carbon fibre prepreg from Hexcel [13]. 8552 is a well-known commercial resin which has been characterised and has a model available for simulation in the Raven software from Convergent [44]. Advise also has a cure model available for 8552 to use with their dielectric sensor system, allowing a test of the calculation of degree of cure, viscosity and  $T_g$  in real time.

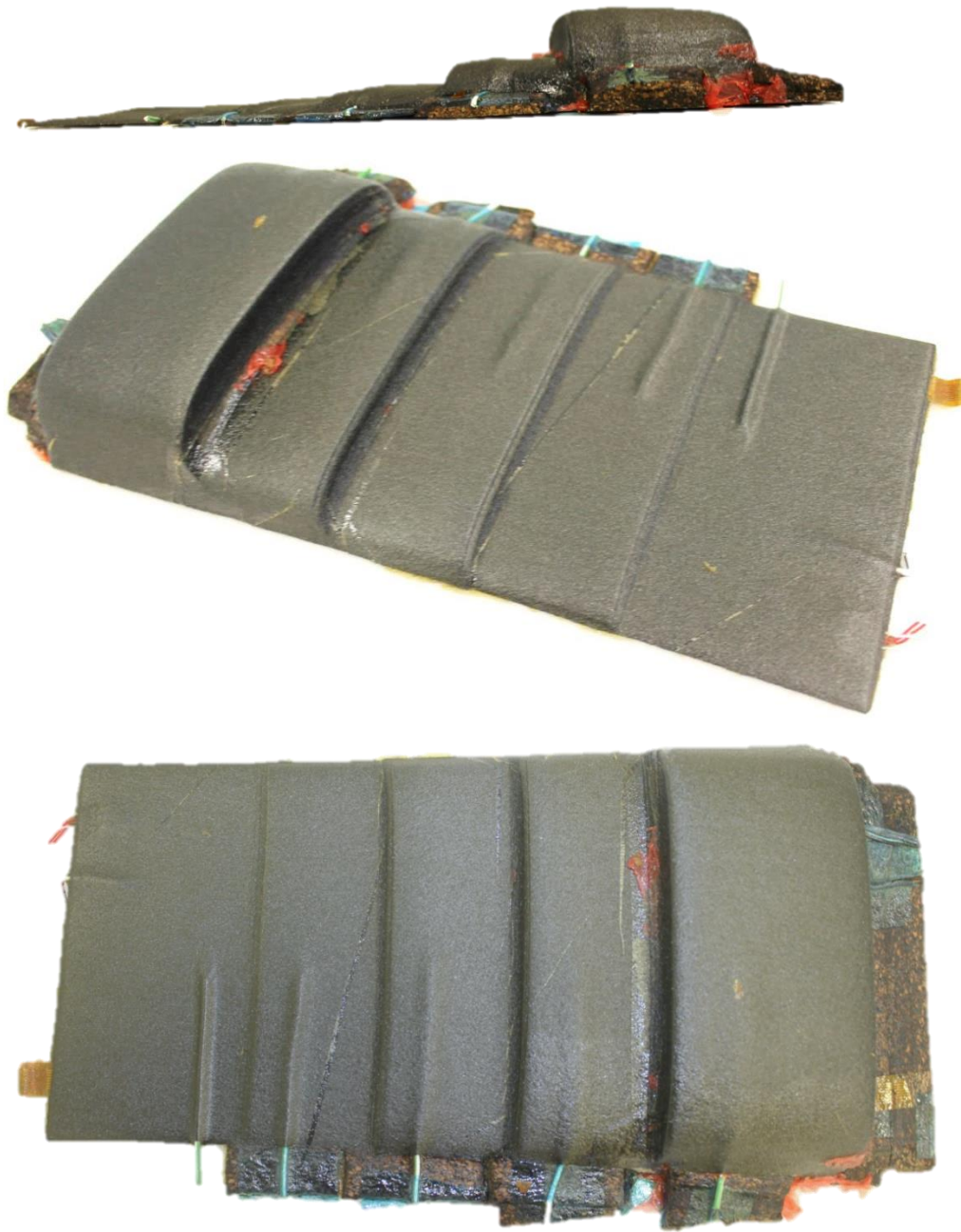

Figure 5.9: Three views of a cured stepped wedge. The wedge is 300mm x 150mm.

The five autoclave control/data monitoring type K thermocouples can be seen exiting each step (green and white) in the photographs (Figure 5.9). The gold strip at each end is a kapton substrate dielectric sensor for the Advise system. It is paired with the black and white type J thermocouple. The red and white cables are attached to the DC sensor- which has integrated temperature sensing. The portion of each step free from sensors is used for DMA and DSC samples, which should be taken from the centre- in all directions- of each step. The red material is release film, which can be difficult to remove completely as it can get stuck between plies as they consolidate. Cork is used to support the sensors to ensure they do not break under vacuum.

## 5.5 Method

### 5.5.1 Test part construction

Each identical test part was laid up by hand on a flat aluminium tool. Embedded sensors were chosen in order to track the cure in the centre of the thin and thick extremes of the part. Synthesites' own sensors were used, which contain a shield and integral glass fibre layer to prevent shorting of the sensor on the carbon fibres.

For use with the Advise system, Kapton substrate electrodes (Netzsch) and GIA electrodes were considered. Preliminary testing found that the GIA sensors absorbed resin becoming dangerous to handle (sharp edges of cured resin) on debugging and also difficult to remove from the connectors. By contrast the Kapton sensors, while more expensive, are more flexible, easier to handle and do not absorb the resin. They also contain an integral glass fibre veil, which the GIA sensors do not. Accordingly, the Kapton sensors were chosen.

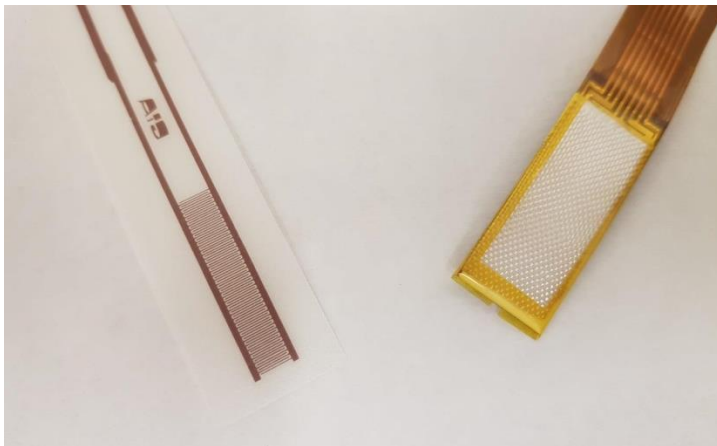
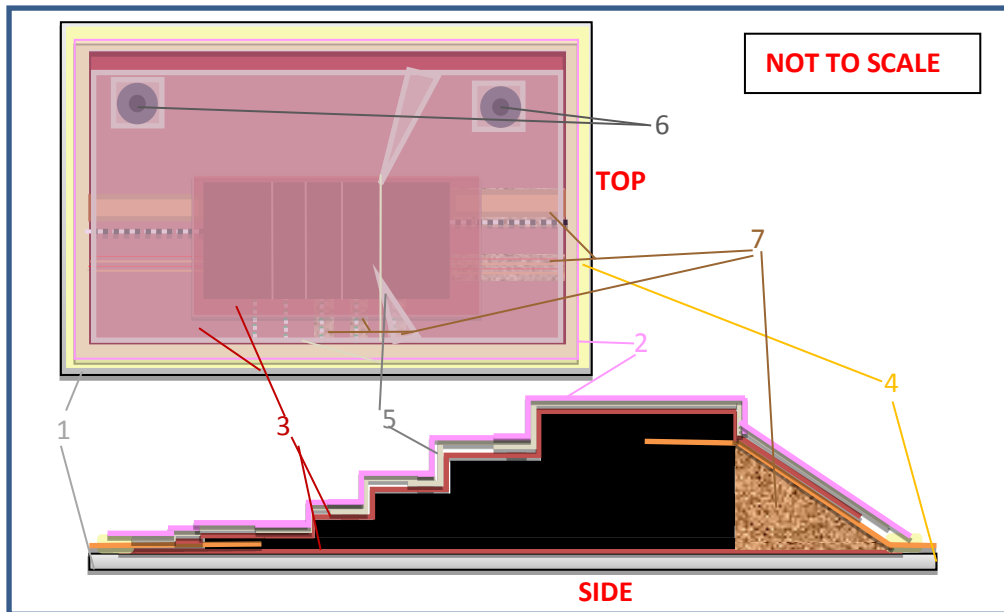

Figure 5.10: A GIA electrode (left) with a Netzsch Kapton substrate electrode (right), as used with the Advise DETA cure monitoring system. The Kapton substrate electrode is approximately 1cm wide. The interdigitated electrodes are visible on the GIA electrode, but hidden under a glass fibre veil on the Kapton electrode. The veil prevents the electrode shorting on conductive material such as carbon fibres.

For each experiment, the part was laid up onto a flat plate and vacuum bagged as in the diagram in Figure 5.11. The thermocouples, sensor strips and cables exit the bag between layers of bagging tape, carefully sealed around them. The bag is tested to ensure there are no detectable leaks prior to placing the part in the autoclave for cure, where it is tested again as part of the autoclave pre-cure procedure.



No.	Description
1	Tool Plate
2	Vacuum bag
3	Release film (non-perforated)
4	Bagging tape (up to 200 °C)
5	Breather fabric
6	Vacuum breach port locations
7	Cork for sensor support

Table 5.1: Vacuum bagging materials

Figure 5.11: Vacuum bagging diagram for the stepped wedge, showing sensor positions, bagging materials and breach ports for vacuum hoses- one to apply the vacuum and another to monitor it.



### 5.5.2 Cure

The part was placed in the instrumented autoclave and the vacuum hoses (source and sensing), 5 standard J type thermocouples (1 in each step), 2 dielectric sensors with K type thermocouples and 2 DC sensors all connected to the relevant points.

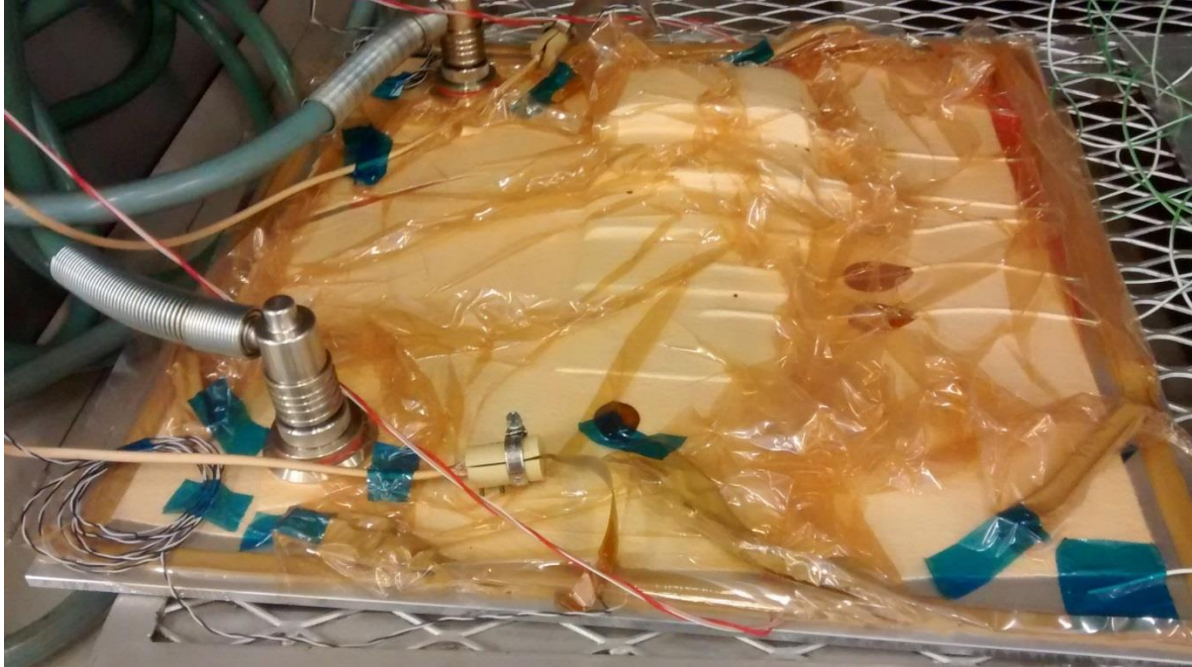

Figure 5.12: A cured stepped wedge in the autoclave with vacuum hoses, DEA sensors (gold strips passing into PEEK connector protection cylinders, J type thermocouples (black and white) and DC sensors (red and white) are connected front and rear. K type thermocouples (green and white) are on the right.

The cure cycles were programmed in to the ASC control PC and the sensor results monitored on a separate laptop. Electricity meter readings were taken after closing and locking the autoclave door but before starting the cure, and at the end of the cycle after the purge fan had finished and the autoclave was cool enough to open safely.



Figure 5.13: The energy monitor on the autoclave electrical cabinet, showing current and total energy usage in kWh. Readings were taken before and after each cure.

### 5.5.3 Use of Cure Monitoring Systems

Each cure monitoring system is read via a laptop PC. The Synthesites Optimold system simply tracks resistance and temperature at each sensor position, with output similar to that in Figure 5.14. This system does not offer real time monitoring of material properties such as  $T_g$  or degree of cure.

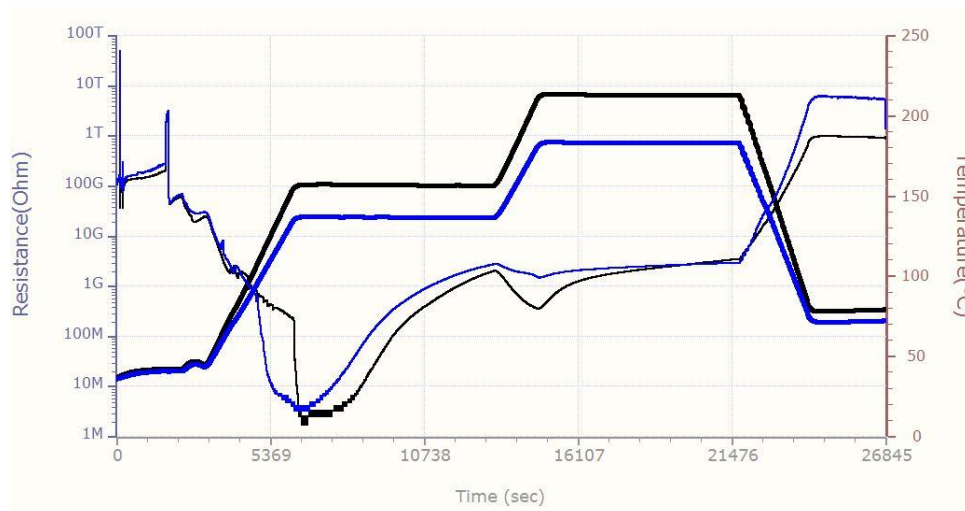

Figure 5.14: Typical output from the Optimold sensors, with two sensors during a two hold cure. Due to the cables used, the values given for temperature and resistance are not accurate- they are later adjusted by reference to the autoclave thermocouples- but the graph shapes indicate the progress of the cure.

After cure, the data are sent to Synthesites along with autoclave thermocouple data for calibration. Synthesites then return an estimate of  $T_g$  during the cure, based on the NCAMP model [23] (see Chapter 2). The same model is used in the Raven simulation software and the Advise DETA system.

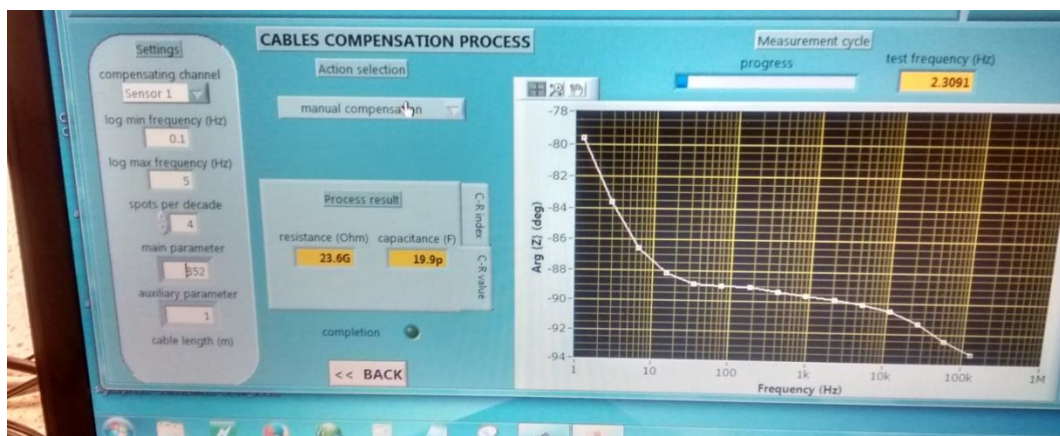

Figure 5.15: Cable compensation in the Advise DETA system

The Advise DETA system must be calibrated to compensate for the effect of cable length on the signal before it is first used with the autoclave pass-through. This is shown in Figure 5.15. Once this has been done, the cable length does not change.

The parameters for the 8552 material model- again based on the NCAMP model, though other details are proprietary- were provided by Advise and must be input manually into the software and checked before each run.

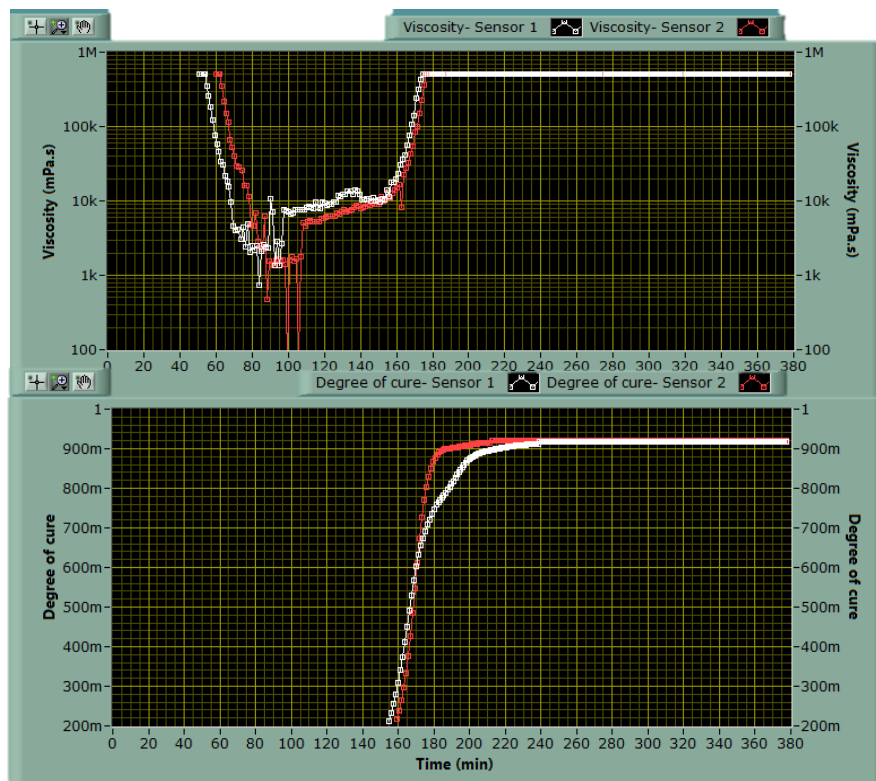

Figure 5.16: Examples of viscosity and degree of cure signals from the Advise DETA system, two sensors shown.

The Advise DETA system provides real time tracking of many material properties, including degree of cure,  $T_g$ , viscosity, conductivity and a breakdown of the response by frequency of the alternating current, shown as the real and imaginary parts of the impedance. For the purpose of this trial, degree of cure and  $T_g$  monitoring was used, though the impedance data can be checked to ensure the response of the resin remains in range- see Chapter 6 for more detail on this.

The final values of degree of cure and  $T_g$  were compared to laboratory tests on the cured part.

#### 5.5.4 DSC and DMA analysis

Following the cure, copies of the sensor and autoclave PC data were taken, and the wedge was sectioned for laboratory analysis. Samples were taken from the centre- horizontally and vertically- of each of the five steps, avoiding the sensors and thermocouples. Differential Scanning Calorimetry, by comparison to an uncured prepreg sample from the same roll, was carried out to estimate the degree of cure. Dynamic Mechanical Analysis, averaged over three samples, was used to estimate the glass transition temperature,  $T_g$ . The cutting, DSC and DMA measurements were carried out by the Materials Laboratory team at the National Composites Centre.



### 5.5.5 Cure simulations with Raven software.

The first set of Raven simulations, referred to as 'Sim', using the NCAMP model for 8552 [23] were carried out before the experiments using simulated temperature data for ideal runs of proposed cure cycles shown in Table 5.2. Each step was modelled as a separate, 1 dimensional heat transfer simulation, with a lower boundary at  $40 \text{ w/m}^2$ , 15mm of aluminium tool, a thickness of 8552 (NCAMP model) correct for that step, 3mm of breather and an upper boundary at  $60 \text{ w/m}^2$ . As the lower boundary is close to the autoclave floor, on a very low trolley, a lower heat transfer seemed reasonable. Values are based on Raven documentation [224]. The results shown for each simulation are for a data point in the centre of the composite layer, equivalent to where the sensors and thermocouples were placed in the test parts.

The second set of Raven simulations, referred to as 'Sim\_data', were carried out after the experiments using the real temperature data from the J type thermocouples embedded in each of the steps, as recorded by the autoclave control PC. These did not involve any heat transfer simulation, only simulation of the cure based on the measured temperature profile.

The ideal cure cycles were found not to reflect reality due to the temperature control behaviour of the autoclave. The difference between the results of the 'Sim' and 'Sim\_data' simulations demonstrates the magnitude of this effect.

## 5.6 Cure Cycles and Active Process Control

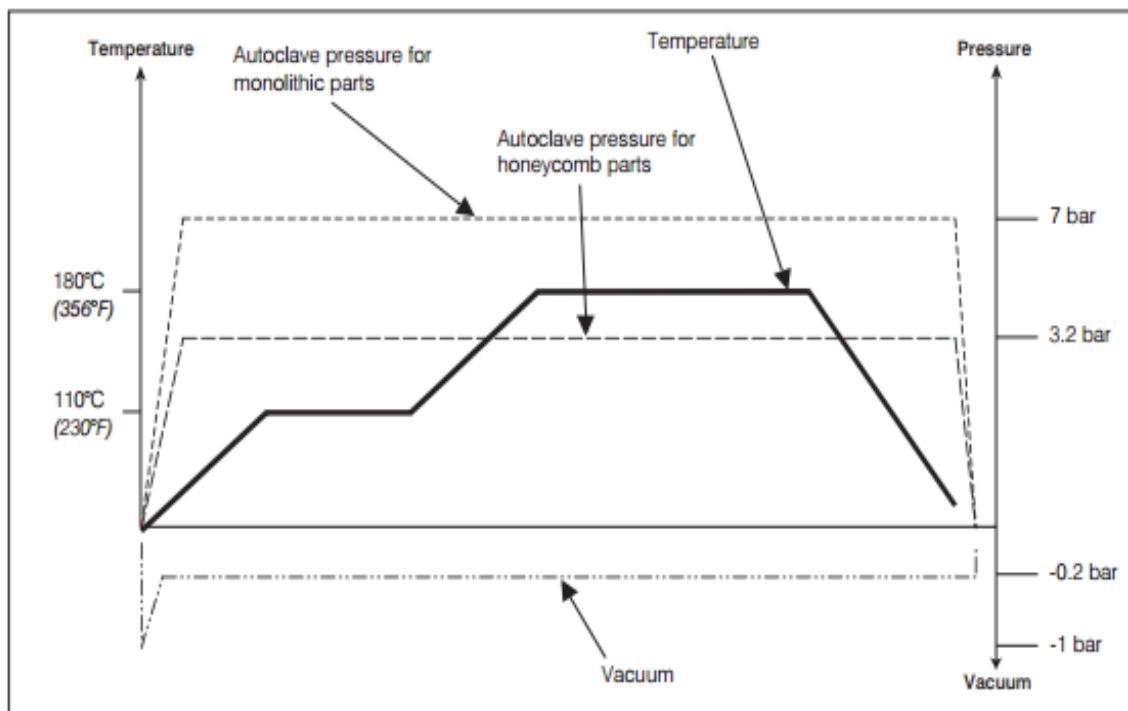

Figure 5.17: The manufacturer's recommended cure cycle for 8552. Reproduced from Hexcel datasheet [13].

All cures were carried out at 7 bar pressure, with a heat up rate of 2°C/min. Cool down rate was 4°C/min.

As a baseline, cures using the standard, recommended cycle (Figure 5.17) and a cycle with a single hold at 180°C for 3 hours were carried out. These are compared to cure cycles truncated when the dielectric sensors indicate that a minimum of 85% degree of cure has been reached, and to lower temperature full length cure cycles intended to reach that same 85% degree of cure.

A minimum of 85% degree of cure was chosen as it is expected that when the thinnest step reaches 85% degree of cure following the manufacturer's recommended cure cycle, the thickest step should be at a measurably higher degree of cure. This should result in a range of data for comparing the results of laboratory tests to simulation and to the sensor measurements.

A Raven process map using the NCAMP model [23] was used to estimate the (second) hold temperature required to achieve 85% degree of cure in all steps for the lower temperature cures.

These were carried out for single and double hold options and again the electricity consumption was measured from the meter. For the double hold option, the first hold was kept at the standard 110°C. This gives a measurement of the energy saving achievable by curing at a lower temperature.

Finally, to evaluate the potential usefulness of cure control using the sensors for this example part, and to compare lowering the temperature with shortening the cure time, both double hold and single hold cures with a (second) hold temperature of 180°C were again carried out. This time data from the Advise sensors was used as an input to the autoclave control system via an ethernet link, and the autoclave programmed to move to the cool down stage when both sensors read over 85% degree of cure. Again, electricity use was measured using the meter.

	Cycle	Ramp to	Hold	Ramp to	Hold	Ramp to	End
1	Recommended	110°C	1 hour	180°C	2 hours	60°C	Purge
2	Single hold	180°C	3 hours	-	-	60°C	Purge
3	2 hold cool	110°C	1 hour	160°C	2 hours	60°C	Purge
4	1 hold cool	160°C	3 hours	-	-	60°C	Purge
5	2 hold DEA triggered	110°C	1 hour	180°C	85% cured	60°C	Purge
6	1 hold DEA triggered	180°C	85% cured	-	-	60°C	Purge

Table 5.2: Cure cycles to be tested.

The results were tabulated, and the end of cure sensor readings compared to DSC and DMA measurements. Potential energy and cost savings were estimated based on the electricity meter measurements.

Two sets of simulations were carried out in Raven, again with the NCAMP model for 8552 [23], these are later referred to as:

Sim- simulations of heat transfer and cure for each step on each cure cycle, using a 1-dimensional heat transfer model based on the theoretical, idealised cure cycles. These were found not to be representative of the real thermal profiles experienced by the part due to the temperature control behaviour of the autoclave, explained in the next section.

Sim\_data- simulations of cure for a point at the centre of each step on each cure cycle, using data from thermocouples embedded in the centre of each step (vertically and horizontally), hence following the actual thermal profiles experienced by the part. As temperature is measured directly and the simulation models the cure only at the point of the thermocouple readings, there is no heat transfer model for these simulations.

The Sim\_data results were compared to the DEA sensor output and to DSC and DMA results for end of cure.

### 5.6.1 180°C cures

To provide both a baseline for energy usage and an initial assessment of the sensor and simulation reliability, Cure 1 followed the manufacturer's recommended cure cycle. Cure 2 was at 180°C without an intermediate hold. It is clear from the thermocouple data that the real conditions in the autoclave are significantly different from the idealised cycle.

The autoclave is controlled by a program, often referred to as a 'recipe' for a given material, set out in segments. A simple recipe might look like this:

- 1) Increase pressure at specified rate up to a set maximum. When pressure reaches SetPressure -1 bar, move to next segment.
- 2) Increase temperature at specified rate up to a set maximum. When low temperature thermocouple reaches SetTemperature -5 degrees, move to next segment.
- 3) Hold at SetPressure and high temperature thermocouple at SetTemperature for X minutes.
- 4) Cool at specified rate to standard room temperature. When high temperature thermocouple reaches SafeTemperature, move to next segment.
- 5) Depressurise at specified rate until standard atmospheric pressure is reached. When pressure reaches LocalPressure, end cure.

The control behaviour for this autoclave can be triggered by the highest or lowest temperature part thermocouple. For safety, when holding at a set temperature- in this case 180°C – the autoclave controls the temperature to keep the highest temperature thermocouple at this set value. This means that when the thicker end of the part begins to overheat due to the exothermic cure reaction, the autoclave acts to lower the air temperature, cooling until the part is back at the required temperature. This cooling means the thinner regions of the part drop in temperature. This can be seen in Figure 5.18 and Figure 5.19. Step 1 is the thin end of the wedge, step 5 the thick end.

The autoclave is programmed to move to the hold segment when the lowest temperature thermocouple reaches a temperature >175°C. This is delayed due to the cooling required to control the exotherm in the thicker region of the part, meaning that while the extremes of thickness experience different cure cycles due to the exotherm, both do receive a minimum of the specified hold time (2 or 3 hours) at the required temperature. However, this makes the overall cycle slightly longer, as time must be allowed for the exotherm and cooling to occur.

At the end of the cure there is a slight pressure drop as the autoclave cools down. The compressed air system it is attached to cannot compensate for the drop in pressure caused by the cooldown before the depressurise segment is reached.

To check consistency between runs, cure 1 was repeated once. The results were consistent within experimental error so, due to time and budget restrictions, other cures were not repeated except where equipment failures occurred. These two cures are referred to as 0 and 1.

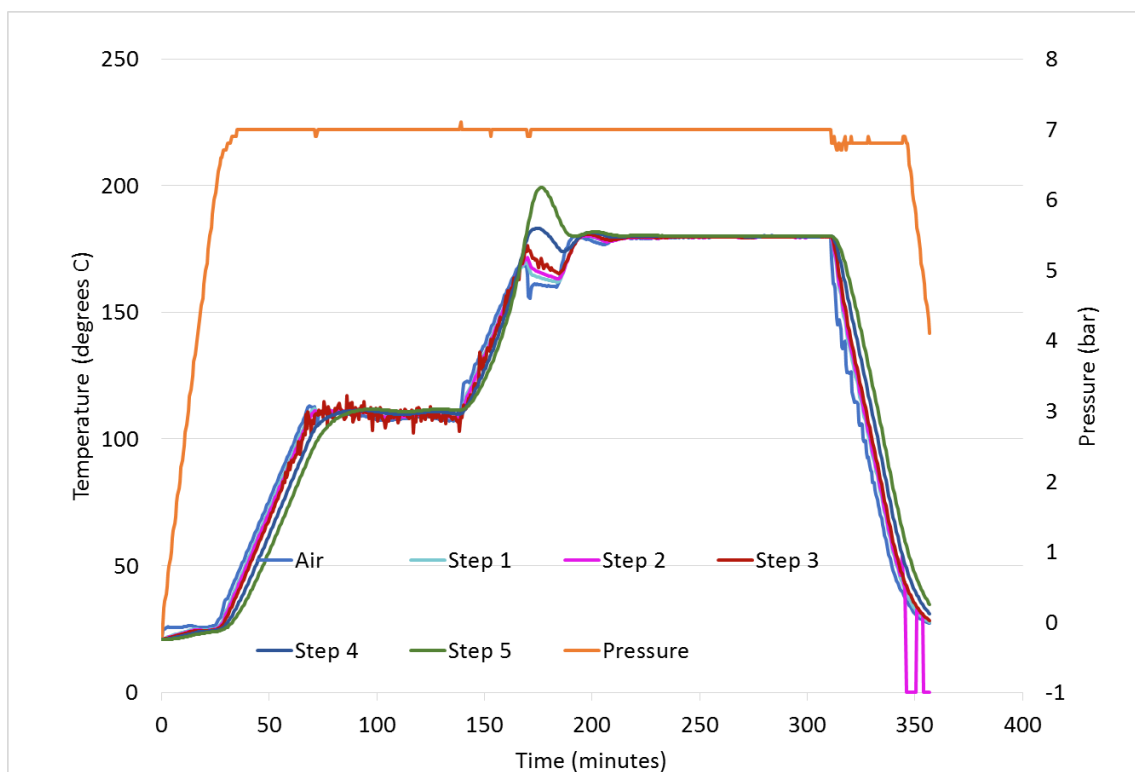

Figure 5.18: Autoclave pressure sensor and thermocouple output for cure cycle 1. Thermocouple 3 is very noisy so was removed as a control thermocouple as the readings were unreliable. Here we can see an exotherm in the thick end just before the 180°C hold

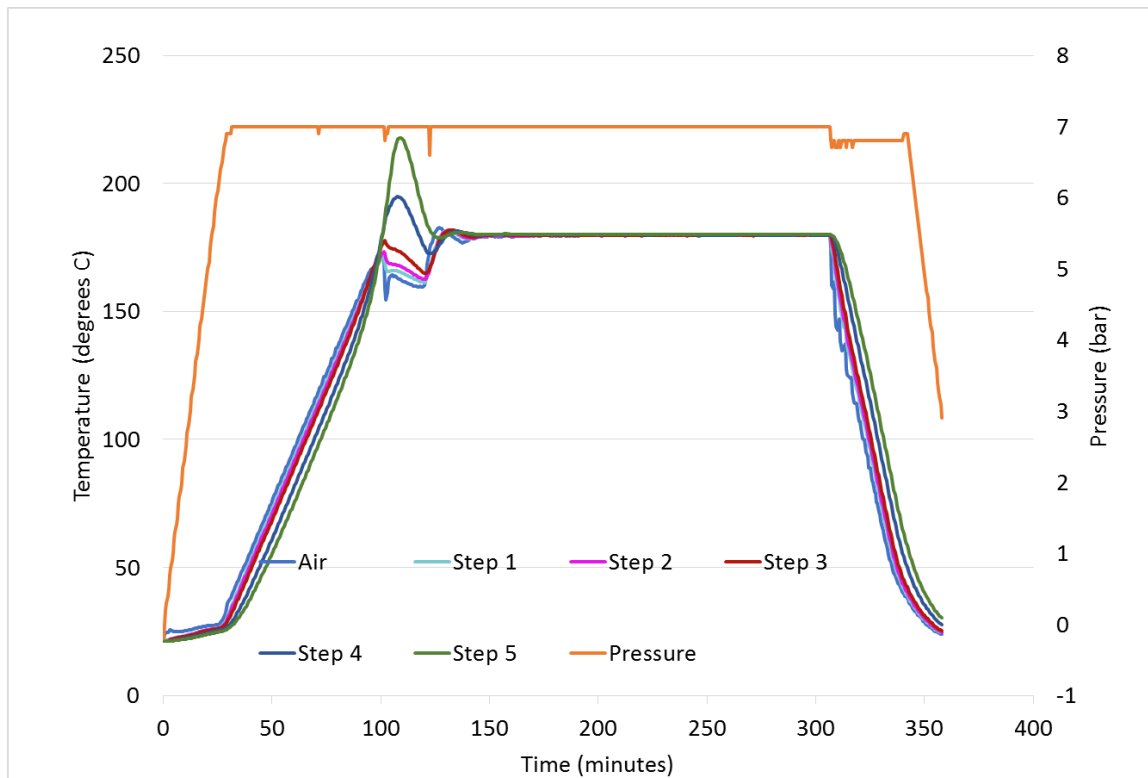

Figure 5.19: Autoclave thermocouple and pressure sensor output for cure cycle 2, a single hold at 180°C. The exotherm occurs just before the cycle enters the 180°C hold.

### 5.6.2 Low temperature cures

Lower temperature cures were carried out, for comparison with the truncated cures. The intention here was to run the autoclave for the same length of time as the standard or single hold cure but at a lower temperature, to compare both the properties of the final material and energy usage to the standard temperature cures truncated at 85% degree of cure.

Figure 5.20 shows the Raven process map used to select the hold temperatures for the low temperature cures. Degree of cure at any moment is read by tracing the cure cycle through the isothermal contours. For example, a part held at 200°C would achieve a degree of cure of 0.6 (60%) after 8 minutes (the second to last green contour). Whereas a part held at 100°C would not be expected to ever achieve 60% cure.

The process map illustrates the issue of diminishing returns for longer cure times, as the rate of increase of degree of cure at any set temperature diminishes with time. The magenta isothermal contours together represent 12 hours, starting at hour 6 of the isothermal cure. At temperatures above 130°C, this additional 12 hours would add less to the degree of cure than the margin of error on NCC's DSC machine. This work investigates, among other things, the possibility of using shorter or lower temperature cures to achieve the desired degree of cure, and the effect this has on  $T_g$ .

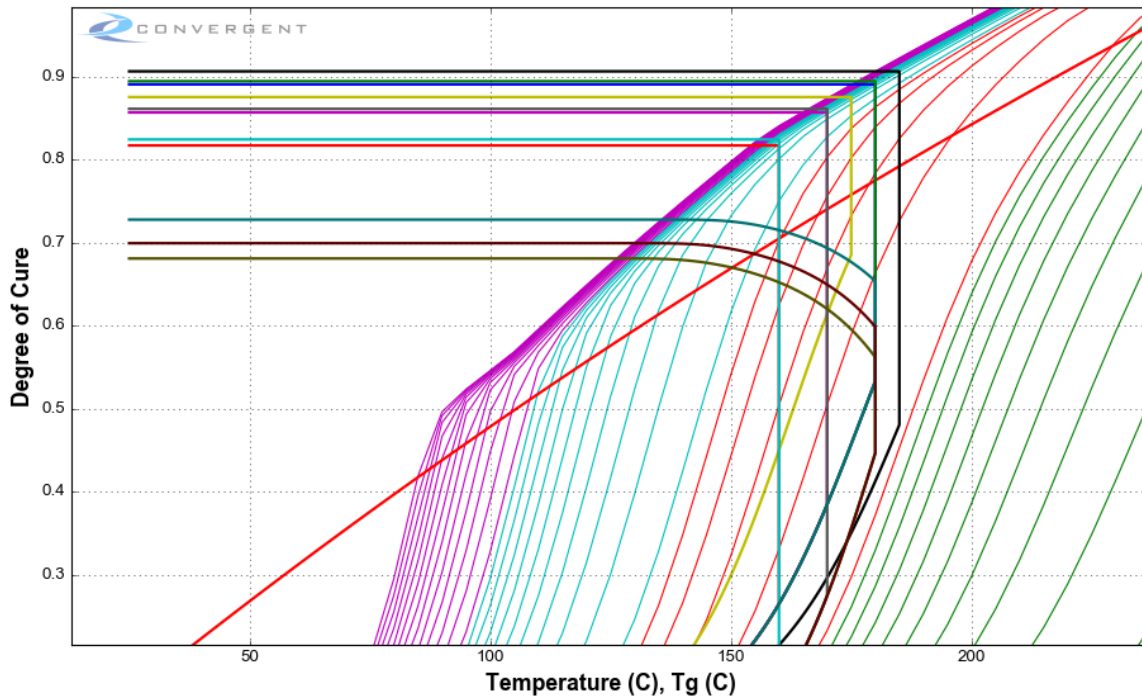

Figure 5.20: Raven process map for 8552 using the NCAMP model, with paths for different cure cycles shown. Isothermal contours have increments of 1 minute (green), 10 minutes (red), 30 minutes (blue) and 60 minutes (magenta). The red diagonal line represents the relationship between degree of cure and  $T_g$ .

The upper, middle, and lower bounds of the manufacturer’s recommended cure cycle are shown by the black, dark blue and yellow lines respectively, with estimates of 91%, 89% and 88% degree of cure. The magenta line illustrates the result (86%) if the second hold is at the lower temperature of 170°C and the red line illustrates the result if the second hold is at 160°C (82%). The green, grey and cyan lines represent single hold cures at 180, 170 and 160°C respectively, with predicted degrees of cure of 89%, 86% and 82%. The dark cyan, dark red and olive lines represent the truncated 180°C, sensor triggered cures- 2 holds with the second lasting 5 minutes, 1 hold lasting 5 minutes and 2 holds with the second lasting 1 minutes, with predicted degrees of cure of 73%, 70% and 68% respectively- less than the target.

As the process maps do not take into account part thickness and both the idealised and data derived simulations underestimated degree of cure compared to the DSC and DEA results for cure cycles 1 and 2, the 160°C case was deemed the most appropriate for Cure 3 (2 holds) and Cure 4 (1 hold).

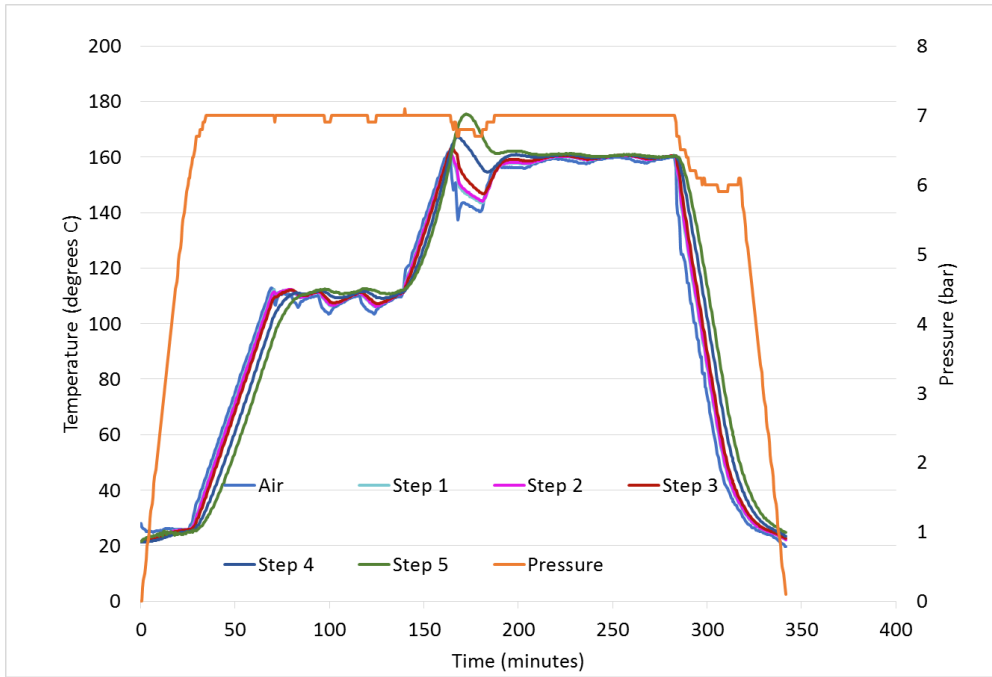

Figure 5.21: Autoclave thermocouple and pressure sensor output for cure cycle 3, a dual hold at lower temperature (for the second hold only).

The fluctuations in temperature during Cure 3 were due to a loose valve on the autoclave trim air which controls the opening and closing of the exhaust. The length of time in the second hold was considered sufficient to mitigate any effect on the results. It should be noted that in service autoclaves can often encounter such problems, so this is a realistic representation of a factory- ASC stated that this was within expected parameters. The problem was fixed before the truncated cures were carried out.



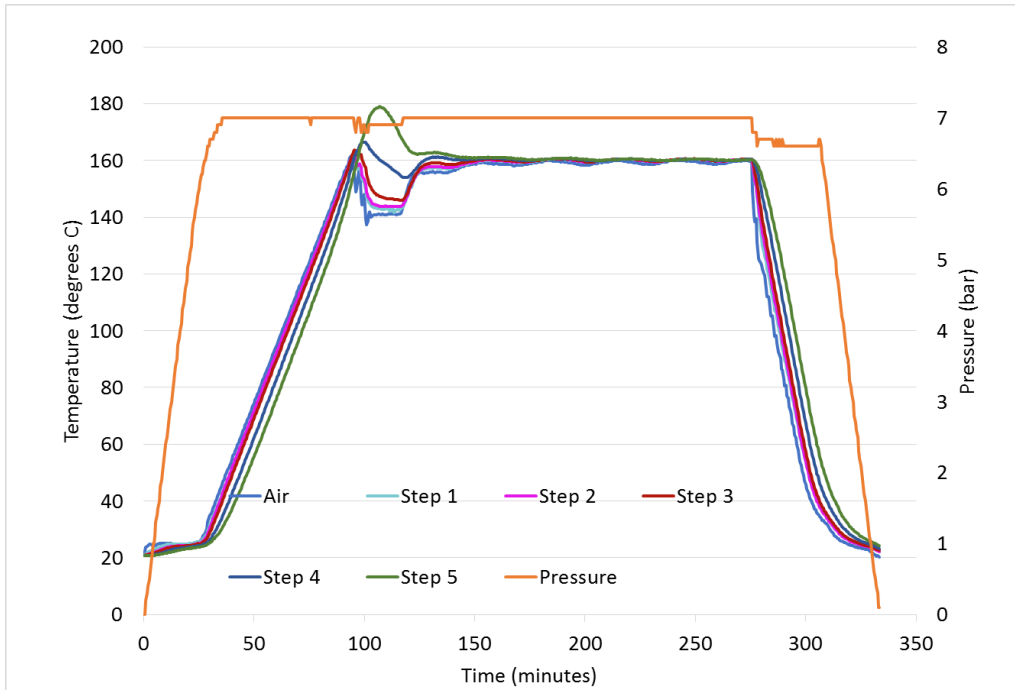

Figure 5.22: Autoclave thermocouple and pressure sensor output for cure cycle 4. The slight depressurisation during the exotherm is due to rapid cooling by the autoclave’s automatic systems, in an attempt to return the thicker end of the wedge to the desired temperature- in this case 160°C.

### 5.6.3 Sensor triggered cures

Changes of segment (e.g. from ‘heat at 2°C/min to ‘hold at 180°C’) are in the normal case triggered by either time elapsed or a sensor reading, usually temperature or pressure. To control based on a signal from the dielectric sensors, the Advise system was connected to the autoclave control PC by Ethernet cable. Advise configured the software to send readings for conductivity, viscosity and degree of cure on each of the 2 channels to the autoclave PC at each timestep. With ASC’s assistance, the autoclave control software was modified to read these values and add them to the list of items which can trigger a change of segment.

It is now possible to trigger a change of segment when a desired conductivity, viscosity or degree of cure is reached at one or both of the dielectric sensors. In order to achieve the lowest energy usage for the required 85% degree of cure, the final two runs (one dual hold and one single hold) were moved to the cool down segment when both sensors registered a degree of cure of 85% or more.

Results are included for both of these, and, for comparison, for a dual hold cycle where the dielectric sensor in the thinner end of the wedge failed, so the autoclave was moved to the cool down part of the cycle after only the thick end had reached 85% degree of cure.

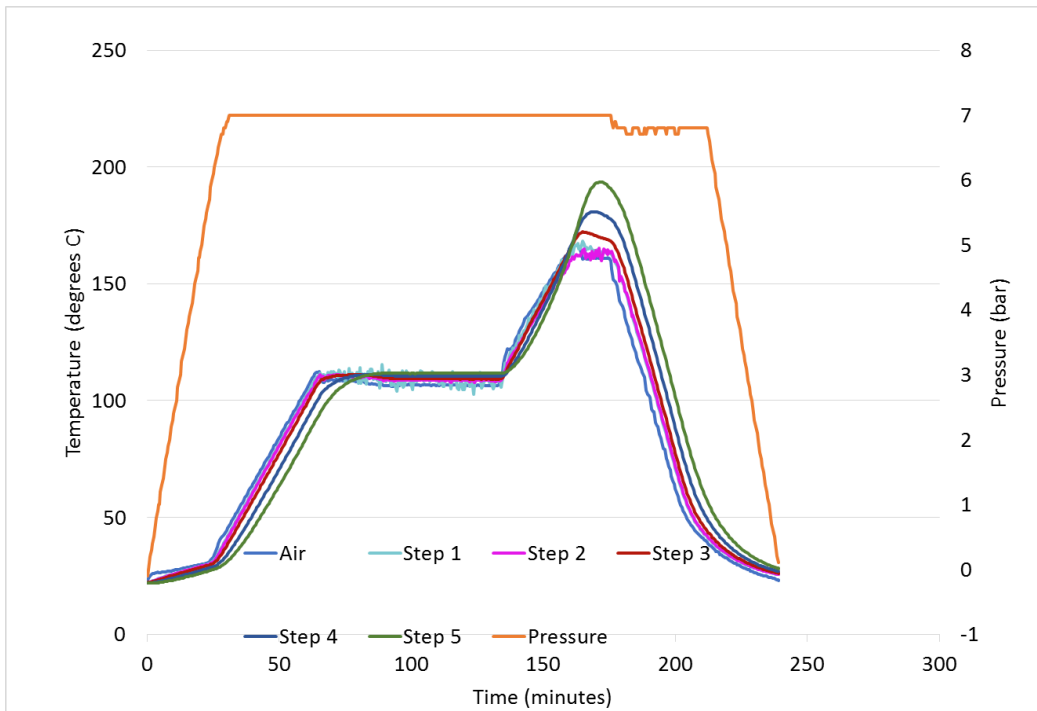

Figure 5.23: Autoclave thermocouple and pressure sensor output for failed cure cycle 5. Here the dielectric sensor in the thin end of the wedge failed, so the autoclave was moved to the cool down segment when only the thick end had reached 85% degree of cure, resulting in a more truncated cure than true cure cycle 5. Hereafter referred to as cycle 7.

This demonstrates the utility of placing sensors in part areas of different thicknesses when seeking to optimise a cure cycle, as triggering the cooldown based only on the thickest step means the thinnest step does not reach the required degree of cure. In this particular instance, a trigger based only on the thinnest step would deliver a minimum of 85% degree of cure to all areas- but we would not have a sensor tracking the difference between the two extremes, and for different materials or part designs it may not necessarily be the thinnest area that reaches the desired degree of cure most slowly.

In all of these cases, the significantly shortened (second) hold means the different steps of the wedge have experienced very different cure cycles, thus, their properties may be expected to vary more than the wedges which underwent standard length cure cycles.

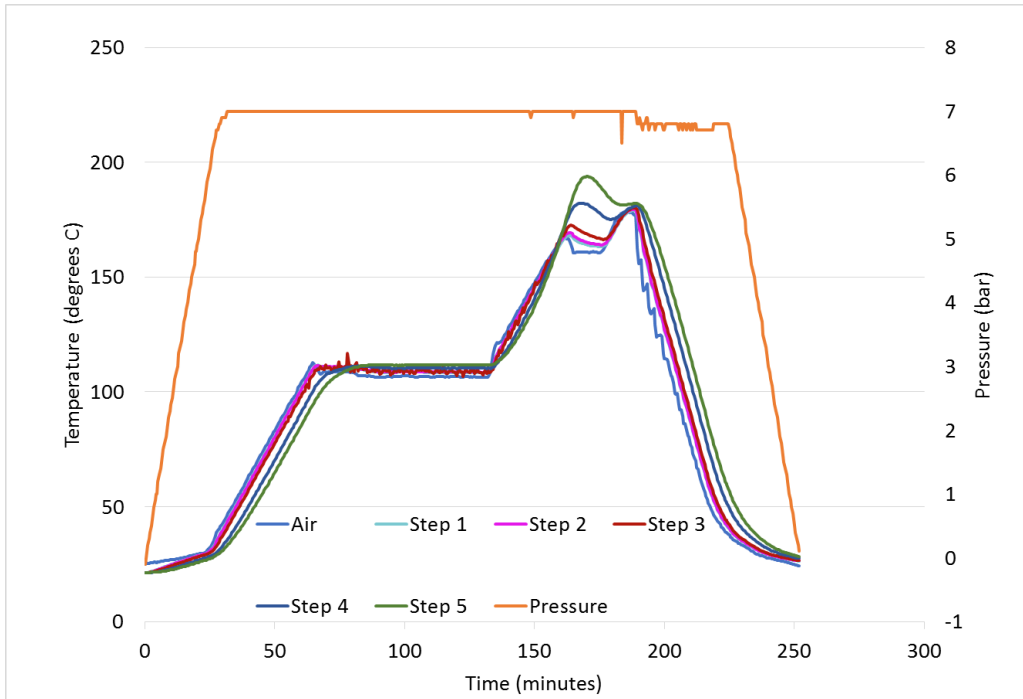

Figure 5.24: Autoclave thermocouple and pressure sensor output for cure cycle 5. After the initial hold at 110°C, the cure proceeds towards a 180°C hold as in cure cycle 1. When the Advise DETA dielectric sensors in both extremes of the wedge report a degree of cure of 85% or more (the thick end reaches 85% first), the autoclave automatically moves to the cool down segment of the cure.

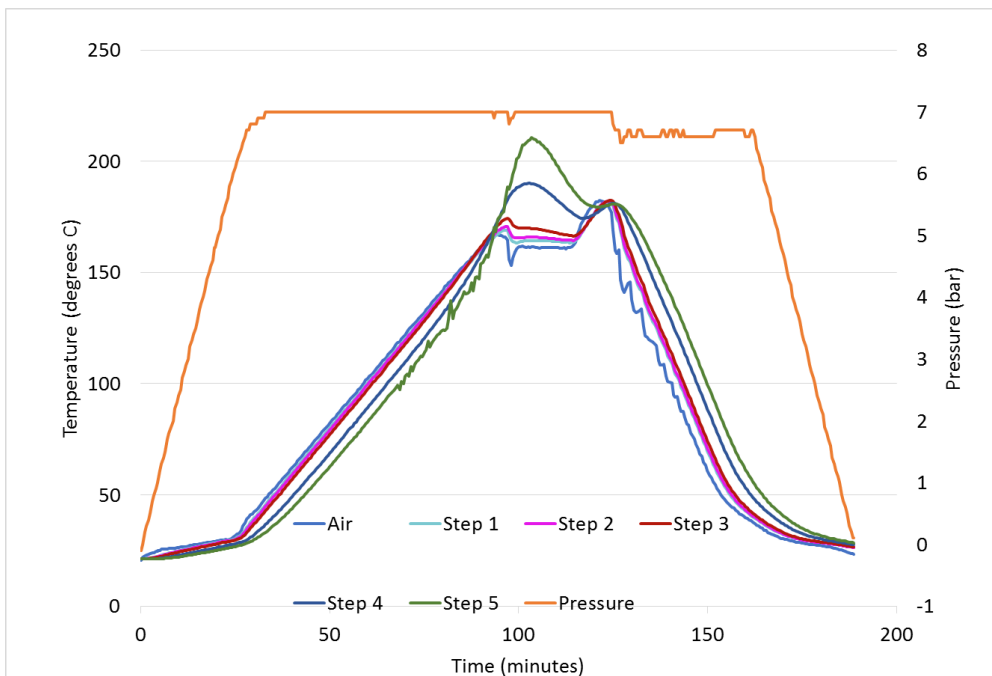

Figure 5.25: Autoclave thermocouple and pressure sensor output for cure cycle 6. The autoclave ramps up the temperature towards 180°C for a single hold, and automatically moves to the cool down phase when the Advise DETA dielectric sensors report a degree of cure of over 85% in both extremes of the wedge.

## 5.7 Results

### 5.7.1 Exotherm temperatures

The thickest end of the wedge, step 5, undergoes a noticeable exothermic reaction in all of the cure cycles, exceeding the desired hold temperature by up to 38 °C in the most extreme case. Step 4 also shows such a reaction, on a smaller scale- the largest step 4 exotherm is 15 degrees above the hold temperature.

	Step 5 exceed hold temp by (°C)	Step 4 exceed hold temp by (°C)
0) Recommended	21	4
1) Recommended repeat	19	3
2) Single hold	38	15
3) 2 hold cool	16	7
4) 1 hold cool	19	6
5) 2 holds truncated	14	2
6) 1 hold truncated	31	10
7) 2 holds over-truncated	14	1

Table 5.3: Exotherm extent in steps 4 and 5, to the nearest °C. The autoclave's stated accuracy is +/- 3°C.

Single hold cures are highlighted and 160°C cures are in italics.

As can be seen in Table 5.3, for the 180°C cures the exotherm on both steps is significantly higher during a single hold cure than a dual hold, demonstrating the effect of the initial 110°C hold in keeping the part closer to the desired cure cycle. For the dual hold cures at 180°C, step 4 remains within the autoclave accuracy of the desired temperature, except for the initial run where it exceeded this by only 1°C.

Step 5 is twice the thickness of step 4, so the larger exotherm is unsurprising, but may represent a limit on the advisable thickness for parts made of this material. For thicker parts, if an exotherm is considered problematic, a dual hold cure cycle- or perhaps even another intermediate hold- could be considered advisable.

Assessing whether or not the exotherm has caused a significant degradation in material properties would be required in order to determine whether or not this is necessary. In this study, only degree of cure and glass transition temperature ( $T_g$ ) were assessed as these also provide points of comparison for the sensor technologies under test.

## 5.7.2 Material properties

### 5.7.2.1 Sample extraction

Each wedge was cut into steps and sectioned, separating the side containing the thermocouples from the 8552 only side. The sensors at the thin and thick extremes were also sliced off or ignored, leaving a usable block of material from each step. The materials laboratory which carried out the tests was instructed to take samples from the centre- in all three directions- of each step (ignoring the extra length for the DC and DEA sensors at each end), or as near as reasonably practical.

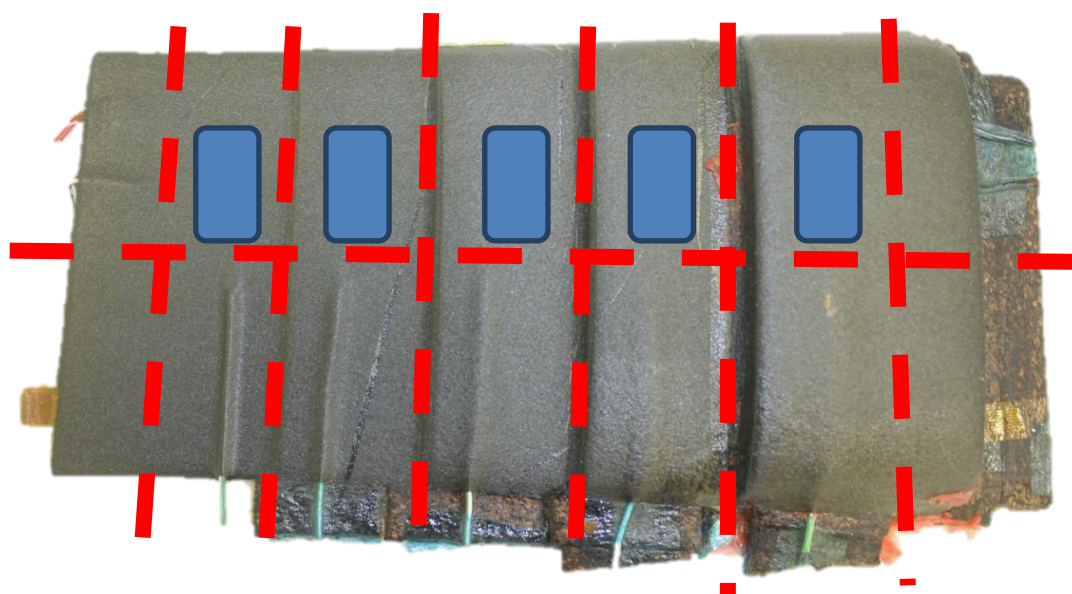

Figure 5.26: Approximate indication of cutting lines (red) and possible sample sites (blue) on stepped wedges, with samples from close to the central red line being preferred. Samples were supposed to be taken from the centre of each step vertically, though in some DMA samples this was not the case. These were repeated and the effect of sample positioning is highlighted in the DMA section.

Cutting the wedges and all DSC and DMA tests, with the exception of one DMA for comparison purposes, was carried out by the NCC Materials Laboratory team.

### 5.7.2.2 Digital Scanning Calorimetry

Digital Scanning Calorimetry tests were carried out with reference to a sample of the uncured 8552 prepreg, from the same roll. The total enthalpy of reaction for the uncured prepreg was measured as  $200\text{J/g} \pm 2\%$ , i.e.  $200 \pm 4\text{ J/g}$

For each step on each wedge, three samples were used for DSC. The degree of cure was calculated by subtracting the residual enthalpy of cure from  $200 \pm 4\text{J/g}$  and dividing the result by  $200 \pm 4\text{J/g}$ . The mean of the three samples is the quoted DSC degree of cure. The error on the mean was calculated for each set of three and found to give a band no larger than  $\pm 0.01$ , often smaller.

However, the acceptance criterion on the calibration certificate for the DSC Q2000 is  $\pm 2\%$  on each measurement of enthalpy, as shown above. As two measurements are used for each degree of cure, propagation of errors gives an error of  $\pm 0.03$  on each individual measurement and  $\pm 0.02$  on each 3 measurement mean. Hence the experimental error from the equipment is greater than the statistical error on the mean for the sets of three. Therefore, the DSC degree of cure quoted below is considered to have an experimental error of  $\pm 0.02$  (or  $\pm 2$  if expressed as a percentage).

	<i>Thin end</i>	Degree of cure by DSC (%), all values $\pm 2$			<i>Thick end</i>
Cure cycle	Step 1	Step 2	Step 3	Step 4	Step 5
<b>0) Recommended</b>	93	95	94	93	95
<b>1) Recommended repeat</b>	93	95	93	94	97
<b>2) Single hold</b>	96	95	96	95	99
<b>3) 2 hold cool</b>	87	87	87	87	88
<b>4) 1 hold cool</b>	86	87	87	88	88
<b>5) 2 holds truncated</b>	88	89	90	93	94
<b>6) 1 hold truncated</b>	88	90	90	93	99
<b>7) 2 holds over-truncated</b>	79	82	83	88	91

Table 5.4: Degree of cure of each step in each wedge as determined by Digital Scanning Calorimetry, taking the mean of three tests for each value.

As shown in Table 5.4, for each of the 6 cure cycles under test all steps exceeded the required minimum of 85% degree of cure, though it should be noted that due to experimental error it is possible that step 1 on the single hold cool run may fall slightly below this, as the possible range is 84% to 88%. Unsurprisingly, in cycle 7, where the cool down was triggered only by the thick end exceeding 85% degree of cure, the thinner end does not reach this requirement. This demonstrates the importance of placing sensors in more than one location for a part of varying thickness.

As might logically be expected, there is less variation in degree of cure in cycles with a longer final hold, where the extra hold time allows the thin end to catch up with the thick end. From the over-truncated cycle 7 it is known that the thick end reaches 85% degree of cure during the exotherm, whereas here the thin end is kept at a lower temperature as the autoclave cools to control the exotherm, leading to the largest range of degree of cure results in a single wedge.

For cure cycles 5 and 6, set to cool down when both ends had reached at least 85% degree of cure, it seems that the cure continues during cooling, as step 1 reaches 88% degree of cure in both cases.

Cure cycles 3 and 4 were also intended to achieve 85% degree of cure by using a lower temperature (second) hold. Both exceeded this slightly, sufficiently that (except in the case of cure 4 step 1) we can be sure that the DSC experimental error does not put them below the required value.

Here the comparison between single and double hold cures only yields a difference in the standard temperature (180 °C (second) hold) regime, whereas for the cool cure cycles, the differences between cycle 3 and cycle 4 are less than the experimental error on the DSC measurement. In the standard temperature regime we see a difference of greater than experimental error at the thick end of the wedge, with the single hold cures achieving a greater degree of cure, almost certainly due to the larger exotherms as shown previously. This suggests that the initial hold at a lower temperature acts to decrease the exotherm in a thick stack of material when the higher temperature is reached.

### 5.7.2.3 *Dynamic Mechanical Analysis*

Dynamic Mechanical Analysis was also carried out on samples from each step of each wedge, in order to determine the glass transition temperature,  $T_g$ , of each. The  $T_g$  value given by the  $\tan \delta$  curve from the DMA result is used here, as this is the value estimated by the model in the DEA software and the Raven simulation.

Here the position of the peak is given by the TA analysis software. Repeated measurements of the same peak using this software showed the variation due to random error could be up to  $\pm 3^\circ\text{C}$ . This must be combined with the error on the machine itself. At the 2016 calibration the DMA machine in question was found to be  $4.49^\circ\text{C}$  out of calibration. As this drifts over time, leading to systematic error, and the measurements were carried out over more than a year, the error may be anything up to this amount. Erring on the side of caution, and adding the possible error in both the DMA output and measurement of the peak, the error can be up to  $\pm 8^\circ\text{C}$ .

An example of the software output is shown in Figure 5.27. For reasons of space, full results for all runs are not shown here. It can be seen that for cure cycle 1, the manufacturer's recommended cure cycle, the  $\tan \delta$  peaks for each step appear to line up. The  $T_g$  estimates for each step are within experimental error of each other- so we expect the whole part to have a very similar  $T_g$ .

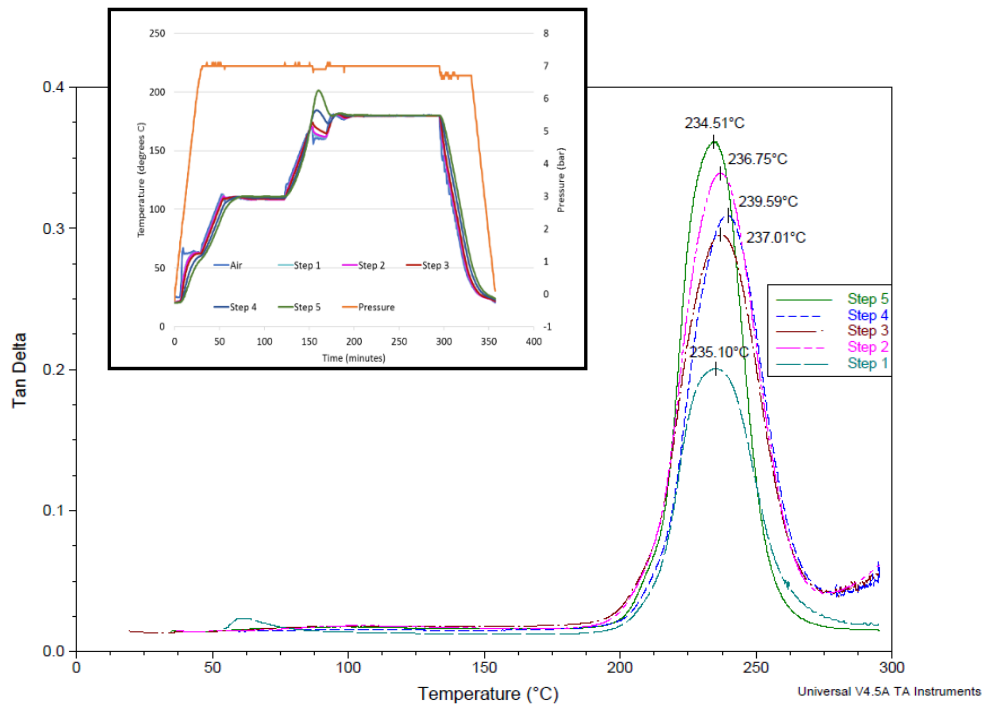

Figure 5.27: DMA results for the first stepped wedge, cure cycle 1 (standard). The cure cycle is shown on the inset graph. Tan  $\delta$  is shown for all five steps, from 1 (thinnest) to 5 (thickest).

#### DMA results

	<i>Thin end</i>	$T_g$ by DMA tan $\delta$ peak(°C), all measurements $\pm 8^\circ\text{C}$				<i>Thick end</i>
Cure cycle	Step 1	Step 2	Step 3	Step 4	Step 5	
<b>0) Recommended</b>	235	237	237	240	235	
<b>1) Recommended repeat</b>	241	236	238	241	238	
<b>2) Single hold</b>	238	233	240	239	229	
<b>3) 2 hold cool</b>	205	212	214	209	212	
<b>4) 1 hold cool</b>	190	194	214	215	216	
<b>5) 2 holds truncated</b>	206	213	216	221	229	
<b>6) 1 hold truncated</b>	211	212	218	227	230	
<b>7) 2 holds over-truncated</b>	172	172	185	206	228	

Table 5.5:  $T_g$  measured by DMA tan  $\delta$  for each step in each wedge. For cure cycle 2, a drop in  $T_g$  can be seen for step 5- this may be due to degradation caused by the exotherm. Anomalous results in red.

For cure 4, the part has been held at 160 degrees for the full hold time and there is little difference in the temperature profiles for step 3 and steps 1 and 2. It is therefore suspected that the anomalously low values for steps 1 and 2 are erroneous. Unfortunately it was not possible to repeat the DMA measurements for cure 4.



### 5.7.3 Technology Evaluation

The Advise DETA dielectric monitoring system (DEA) calculates  $T_g$  and degree of cure based on the material response to the alternating current, along with an in-built mathematical model of the resin. This model is based on the NCAMP model for 8552 [23], the same as is used in the Raven simulations and the post-processed estimates of  $T_g$  provided by Synthesites. In this model  $T_g$  and degree of cure are not independent, one can be calculated from the other. However, the laboratory based tests for each are independent, so provide two points of comparison for the technologies being evaluated.

	Cycle	Ramp to	Hold	Ramp to	Hold	Ramp to	End
0	Recommended	110°C	1 hour	180°C	2 hours	60°C	Purge
1	Recommended	110°C	1 hour	180°C	2 hours	60°C	Purge
2	Single hold	180°C	3 hours	-	-	60°C	Purge
3	2 hold cool	110°C	1 hour	160°C	2 hours	60°C	Purge
4	1 hold cool	160°C	3 hours	-	-	60°C	Purge
5	2 hold DEA triggered	110°C	1 hour	180°C	85% cured	60°C	Purge
6	1 hold DEA triggered	180°C	85% cured	-	-	60°C	Purge
7	2 hold over-truncated	110°C	1 hour	180°C	85% step5	60°C	Purge

Table 5.6: Cure cycles. The reader is strongly advised to take a photograph of this for easy reference.

#### 5.7.3.1 Comparison of sensor results, laboratory tests and simulation

##### *Raven simulations*

Two sets of simulations were carried out in Raven, both using the NCAMP model for 8552. The material model for Hexcel 8552 in Raven refers to an AGP 193-PW (woven) reinforcement. This should be equally applicable to the case of the unidirectional IM7/8552 used here as the reinforcement should not affect the resin cure. The two sets of simulations are referred to as:

Sim- simulations of heat transfer and cure for each step on each cure cycle, using a 1-dimensional heat transfer model based on the theoretical, idealised cure cycles as described in Table 5.2.

Sim\_data- simulations of cure for a point at the centre of each step on each cure cycle, using data from thermocouples embedded in the centre of each step (vertically and horizontally), hence following the actual thermal profiles experienced by the part. As temperature is measured directly and the simulation models the cure only at the point of the thermocouple readings, there is no heat transfer model for these simulations.

As the autoclave cools automatically in an attempt to control the exotherm in the thick end of each part, and considers each hold to have started only after the thinnest end is within 5°C of the target temperature, the real temperature profiles are always different to the theoretical cure cycles. This explains the significant difference between the Sim results and all other measurements.

For Sim\_data, the data from each thermocouple embedded in the part during the cure was imported into Raven and used to create a cure cycle, and for each a simulation of the cure of the material based on the actual temperature history was created.

The difference between the theoretical cure cycle used in the initial Sim and that measured by the thermocouples for each step used in Sim\_data result in different estimates of degree of cure and  $T_g$ , as can be seen by comparing Figure 5.28 and Figure 5.29.

This is likely to be unaffected by the choice of boundary conditions as the difference between the temperature profiles is significant.

The theoretical, Sim, model for step 5 of cure cycle 1 predicts an exotherm to 275°C in the centre of step 5, 95°C above the desired hold temperature (Figure 5.28). The effect of autoclave cooling on the extent of the exotherm is notable, as the actual exotherm of 21°C is far smaller(Figure 5.29).

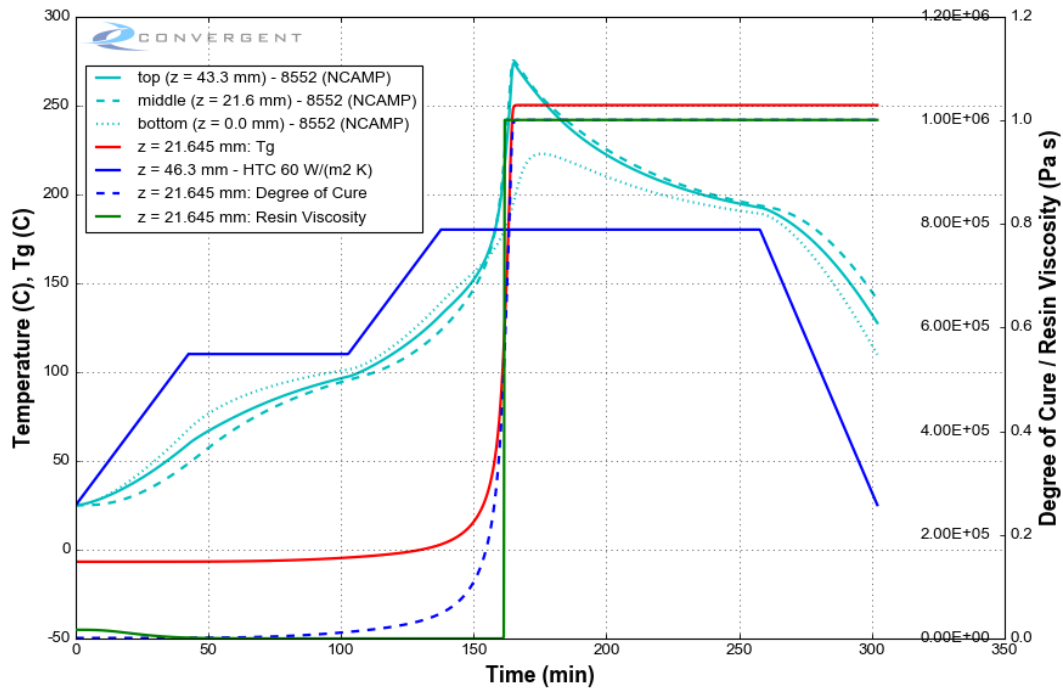

Figure 5.28: Sim: Theoretical simulation for Step 5 in cure cycle 1. The cure cycle is shown in blue, and the expected temperature of the part at the top (full line) middle (dashed line) and bottom (dotted line) is in cyan. Degree of cure (blue dashed line),  $T_g$  (red line) and resin viscosity (green line) are shown for the centre of the step. Degree of cure is on the external right axis and resin viscosity on the internal right axis.

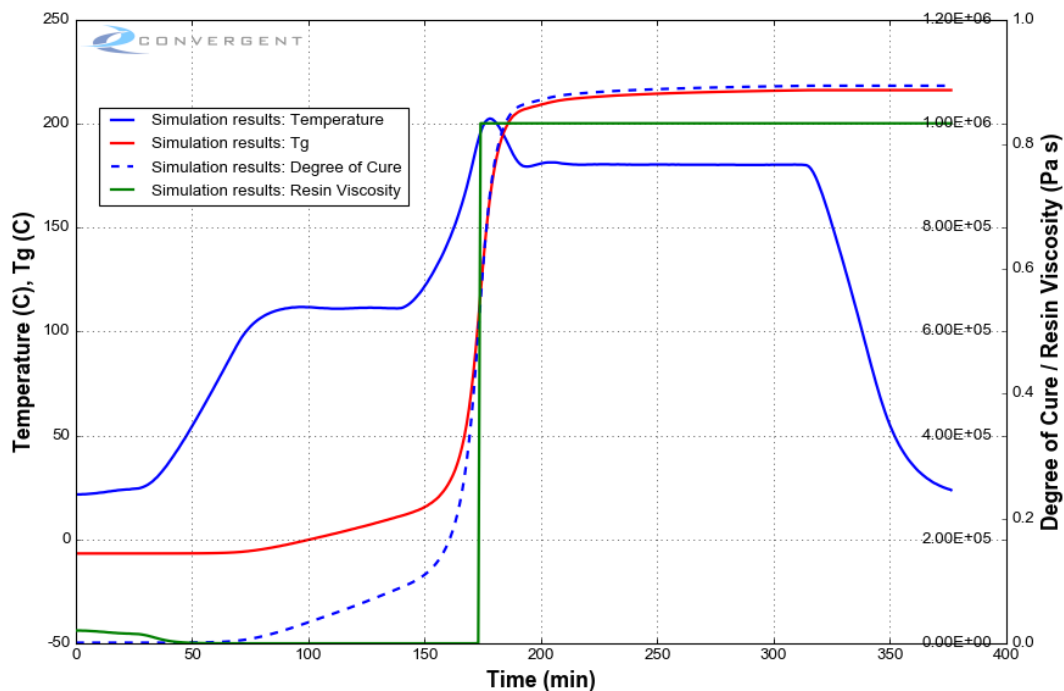

Figure 5.29: Sim\_data: Simulation for Step 5 of cure cycle 1 based on thermocouple data from the centre of the step. The temperature profile from the thermocouple is the blue line. Degree of cure is on the external right axis and resin viscosity on the internal right axis.

Both the Sim and Sim\_data simulations can be compared to the results of the DSC and DMA laboratory tests. If simulation is to be used in optimising cure cycles, it is useful to know how closely this may represent reality.

**$T_g$  (°C) by DMA, simulation from thermocouple data and theoretical cure simulation**

Cure	Step 1			Step 2			Step 3			Step 4			Step 5		
	DMA ±8°C	Sim_ data	Sim	DMA ±8°C	Sim_ data	Sim	DMA ±8°C	Sim_ data	Sim	DMA ±8°C	Sim_ data	Sim	DMA ±8°C	Sim_ data	Sim
0	235	215	215	237	215	216	237	215	219	240	215	244	235	216	250
1	241	215	215	236	215	216	238	215	219	241	215	244	238	216	250
2	238	216	216	233	216	217	240	216	220	239	216	250	229	219	250
3	205	192	193	212	192	194	214	192	198	209	193	233	212	194	250
4	190	194	195	194	195	196	214	195	199	215	195	230	216	196	250
5	206	182	145	213	184	154	216	188	175	221	198	220	229	207	250
6	211	181	127	212	183	135	218	188	156	227	202	186	230	212	21
7	172	148	127	172	142	135	185	160	146	206	176	204	228	195	221

Table 5.7:  $T_g$  by DMA compared to Raven simulations based on thermocouple data (Sim\_data) and on theoretical cure cycles and heat transfer model (Sim). Results for each step from thin (Step 1) to thick (Step 5). DMA results in red are considered anomalous.

**Degree of cure(%) by DSC, simulation from thermocouple data and theoretical cure simulation**

Cure	Step 1			Step 2			Step 3			Step 4			Step 5		
	DSC ±2%	Sim_ data	Sim	DSC ±2%	Sim_ data	Sim	DSC ±2%	Sim_ data	Sim	DSC ±2%	Sim_ data	Sim	DSC ±2%	Sim_ data	Sim
0	93	89	89	95	89	89	94	89	90	93	89	98	95	89	100
1	93	89	89	95	89	89	93	89	90	94	89	98	97	89	100
2	96	89	89	95	89	90	96	89	91	95	90	100	99	90	100
3	87	81	82	87	81	82	87	82	84	87	82	92	88	82	100
4	86	82	82	87	82	83	87	82	84	88	83	94	88	83	100
5	88	78	65	89	79	68	90	80	76	93	83	91	94	86	100
6	88	78	59	90	79	61	90	80	69	93	85	79	99	88	14
7	79	66	58	82	64	61	83	70	65	88	76	86	91	82	91

Table 5.8: Degree of cure by DSC compared to Raven simulations based on thermocouple data (Sim\_data) and on theoretical cure cycles and heat transfer model (Sim). Results for each step from thin (Step 1) to thick (Step 5).

■ DMA   ■ Sim\_data   ■ Sim

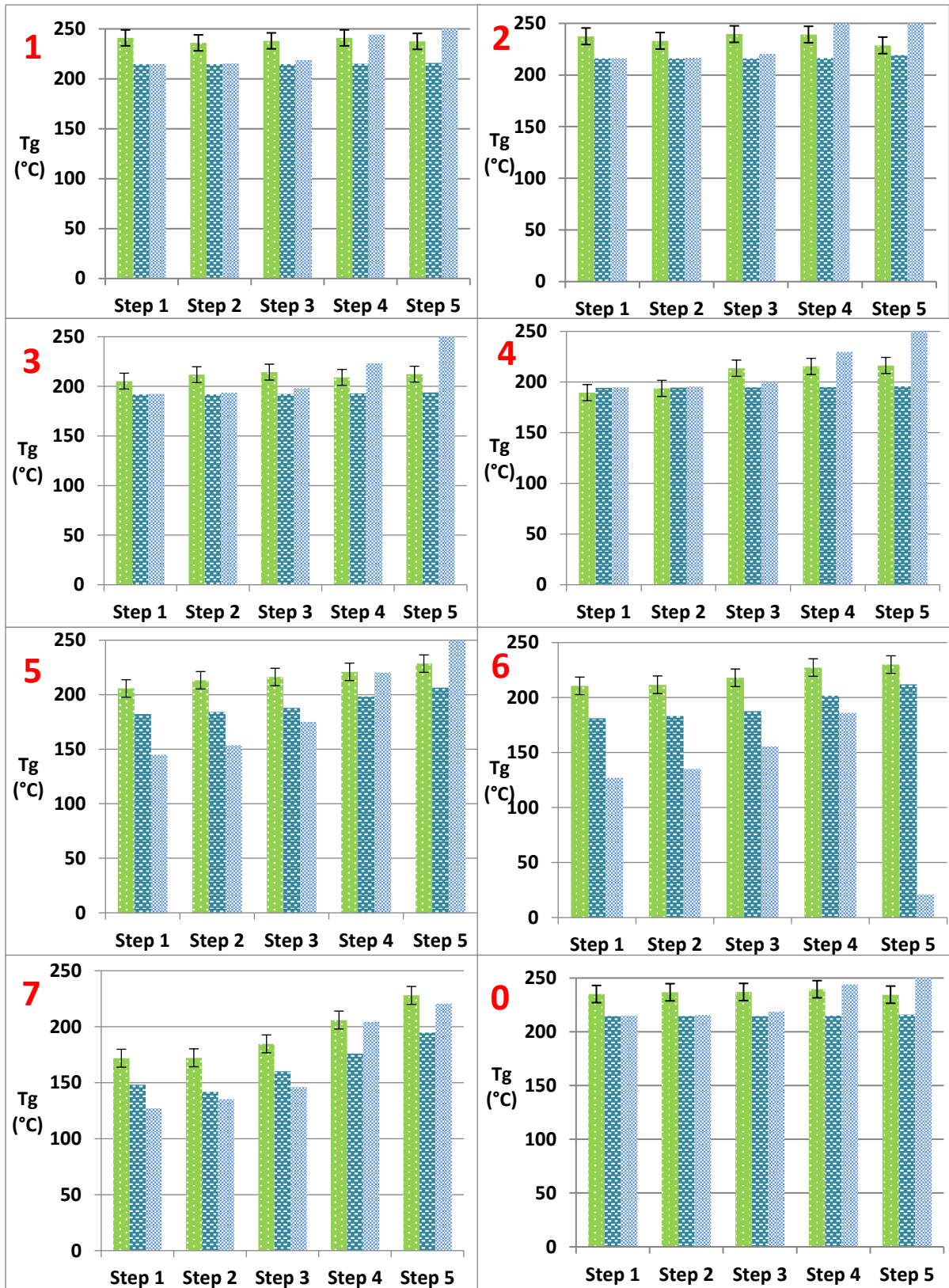

Figure 5.30: Comparison of  $T_g$  by DMA tan  $\delta$  peak (green), Raven simulation based on thermocouple data (Sim\_data)(darker blue) and Raven simulation based on theoretical cure cycle (Sim) (lighter blue).

The comparison for  $T_g$  is shown in Figure 5.30. It is notable that the simulation based on real thermocouple data, Sim\_data, gives consistently lower values than that measured by DMA, with the exception of Steps 1 and 2 for cure cycle 4, which; as highlighted in Table 5.5, should be considered unreliable.

The difference between the theoretical, Sim, and actual, Sim\_data, temperature profiles on the output of the Raven simulation is demonstrated by steps 4 and 5 in all cure cycles, showing the effect of the autoclave cooling on the temperature in the thicker steps. For the truncated cycles, 5-7, this can also be seen in the thinner steps, as they cool along with the autoclave and hence spend little or no time at the desired hold temperature before the cooldown.

As  $T_g$  and Degree of cure are linked in the NCAMP model, the expected reflection of the results in Figure 5.30 is seen in Figure 5.31, with the theoretical simulation, Sim, showing differences to that based on thermocouple data, Sim\_data, in accordance with the autoclave behaviour, with the addition of a very low degree of cure for step 5 in cure cycle 6. Notably, the theoretical simulation, Sim, predicts that step 5 in cure cycle 6 will not reach the required hold temperature, whereas in reality we see an exotherm, supporting the assertion that simulation based on theoretical, ideal cure cycles may be of limited use in modelling the behaviour of a real autoclave, particularly where there is a significant variation in part thickness as is the case here.

The difference between the  $T_g$  predicted by the simulation when based on the thermocouple data, Sim\_data, and the  $T_g$  measured by the DMA is greater than the experimental error on the DMA, suggesting that the model as implemented in the Raven software is not quite representative of laboratory results. Disregarding steps 1 and 2 for cure cycle 4, a mean offset of 23°C with standard deviation of 5°C and error on the mean of 1°C is found, though this is unlikely to be a constant- it can be seen from the graphs in Figure 5.30 that the offset is lower for the cool cure cycles, and higher for the truncated cure cycles.

▨ Sim   
 ▨ Sim\_data   
 ▨ DSC

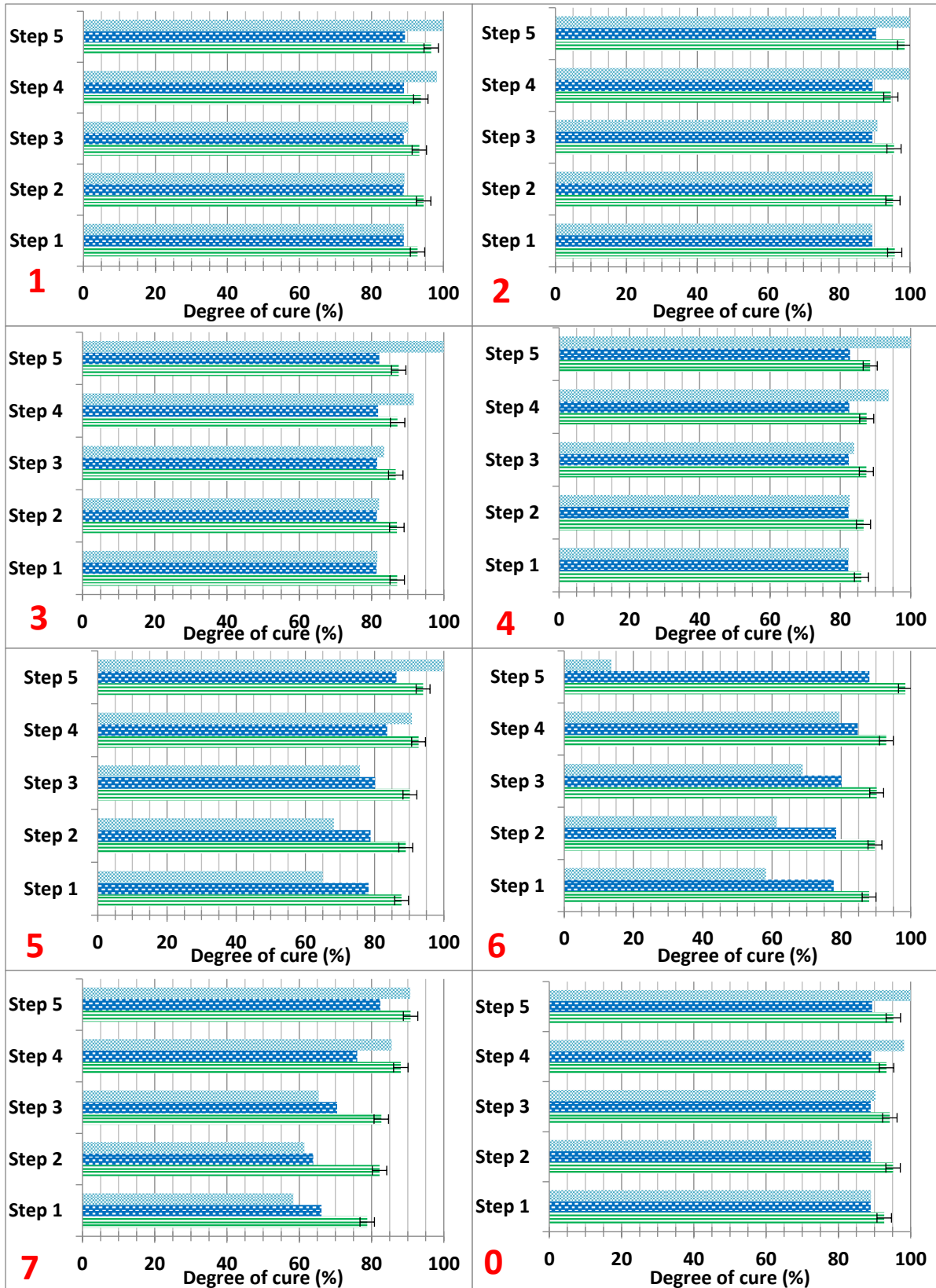

Figure 5.31: Comparison of Degree of Cure by DSC (green), Raven simulation based on thermocouple data (Sim\_data) (darker blue) and Raven simulation based on theoretical cure cycle (Sim) (lighter blue).

Similarly, a comparison between the two types of Raven simulations and the DSC measurements of degree of cure can be seen in Figure 5.31. As for  $T_g$ , the simulations based on thermocouple data, Sim\_data, give lower estimates of degree of cure than the readings obtained in laboratory tests.

As Sim\_data tends to give lower values than the DSC results, in the cool cure cycles 3 and 4 one finds that while the simulation does not expect the material to quite reach the required 85% degree of cure, in line with the process map (Figure 5.20) prediction of 82%, the DSC results indicate that this has been achieved for all steps in both cure cycles. Truncated cure cycles 5 and 6 also achieve in excess of the required 85% degree of cure in all steps, though Sim\_data predicts that only the thicker steps would achieve this. The difference between Sim\_data and the DSC result is far larger for the truncated cures, especially the thinner steps in the over-truncated cure cycle 7.

As the simulation based on ideal cure cycles, Sim, is not representative of the real cure cycles carried out in the autoclave, only the simulation based on real temperature data, Sim\_data, is used for comparison to laboratory and DEA data hereafter.

The validity of the model as implemented in the Raven simulation may be further investigated by comparing the  $T_g$ -degree of cure relationship from the simulation based on real thermocouple data, Sim\_data, to the implied relationship from the DSC and DMA results. Figure 5.32 shows this relationship for the laboratory tests. While there is some variation, a clear trend can be seen and similar cure cycles are grouped together.

Figure 5.33 shows the relationship for Sim\_data, which, by comparison to Figure 5.34 can be seen to follow the  $T_g$ -degree of cure relationship from the NCAMP model as expected, which follows the DiBenedetto model [40]–[42] as in Equation 2.14 using the parameters shown in Figure 5.34 ( $\alpha$  is degree of cure), thus:

$$\frac{T_g + 7^\circ\text{C}}{250^\circ\text{C} + 7^\circ\text{C}} = \frac{0.78\alpha}{1 - (1 - 0.78)\alpha} \quad (5.1)$$

However, comparing the two datasets, DSC-DMA and Sim\_data, as shown in Figure 5.35, shows significant differences between the Raven results and those measured in the laboratory.

The model does not include the drop in  $T_g$  due to degradation at a high degree of cure, which we see in the step 5 results for the two full temperature single hold runs. This is expected based on Figure 5.34.



Removing the results due to  $T_g$  degradation and the two anomalous results from cure 4 it can be seen in Figure 5.35 that the Sim\_data results are uniformly lower in both  $T_g$  and degree of cure than the laboratory measurements, but the majority of the laboratory measurements- with the exception of the most undercured steps from the over-truncated cure cycle 7- appear to be within experimental error of the trendline formed by the Sim\_data results, which is the NCAMP  $T_g$ -degree of cure relationship. The Raven simulation based on this model cannot be considered reliable for use in cure optimisation for this dataset without a correction (estimated by eye to be approximately +5% degree of cure and +20°C  $T_g$ ), as the simulation results lie far lower on the trendline than those obtained by laboratory measurements.

This suggests that the lower figures given by the Sim\_data Raven simulations are unlikely to be due to the relationship between  $T_g$  and degree of cure, so the discrepancy may be due to a difference between the cure kinetics model (or implementation thereof) and the behaviour of the resin. The cure kinetics model is given in Chapter 2 and the NCAMP for Raven documentation [44]. This is based on laboratory tests carried out using material bought in 2006, with results presented in 2009 [23], [44]. As these tests were carried out approximately a decade prior to the work presented here, it is possible that a change has been made to the resin formulation- or that there is significant variation between batches.

The results from cure cycle 7 suggest there may also be an issue with the  $T_g$ -degree of cure relationship at lower degrees of cure, but from this limited dataset this cannot be ascertained with any certainty.

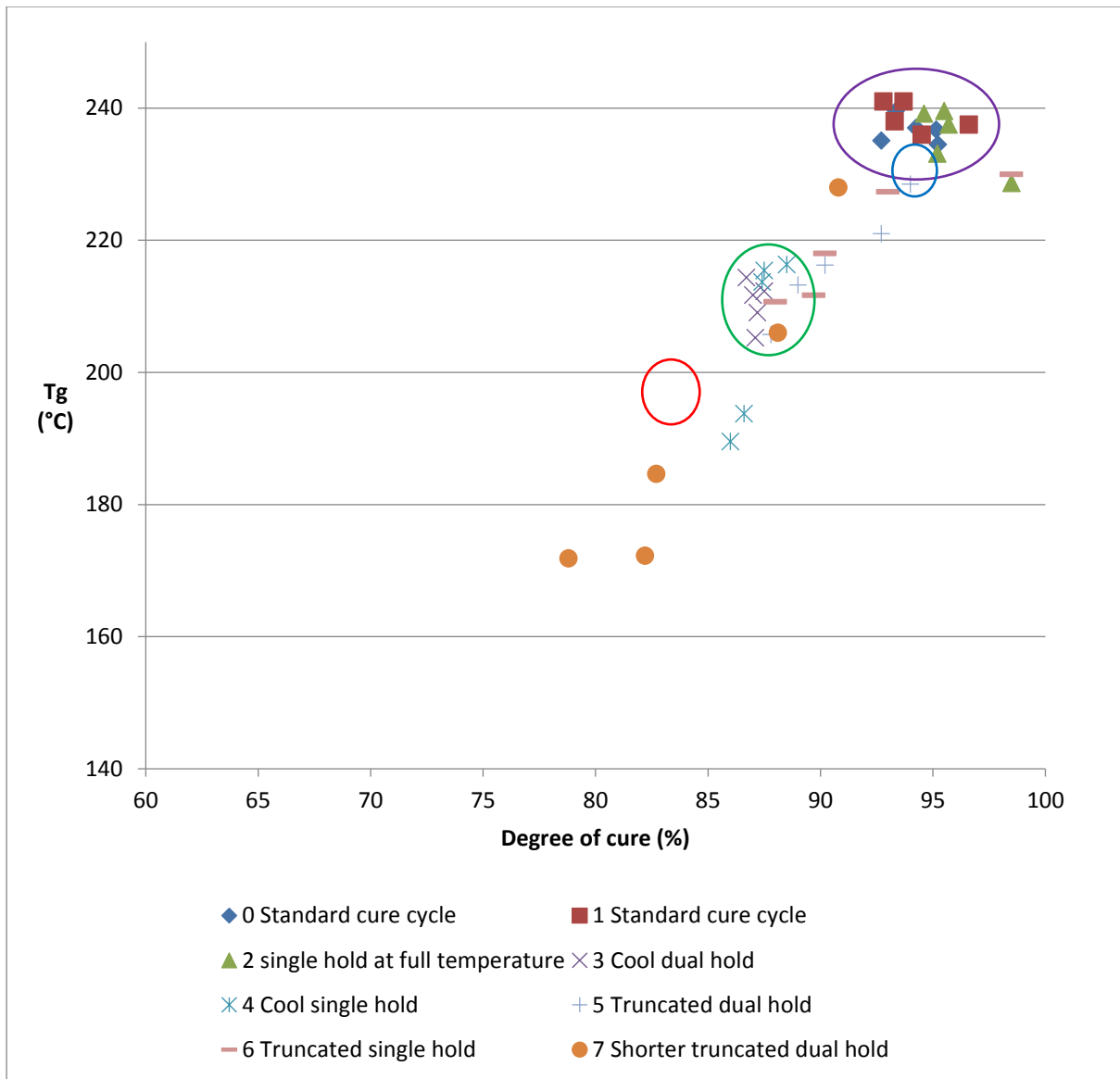

Figure 5.32:  $T_g$  - degree of cure relationship for 8552 based on laboratory tests, DMA  $\tan \delta$  peak and DSC respectively. Red oval: steps 1 and 2 for cure cycle 4, DMA thought to be anomalous. Blue oval: step 5 from cure cycles 2 and 6, where the exotherm is highest and degree of cure is highest. Purple: Standard temperature full length cure. Green: cool full length cures. Error bars are not shown here for ease of viewing.

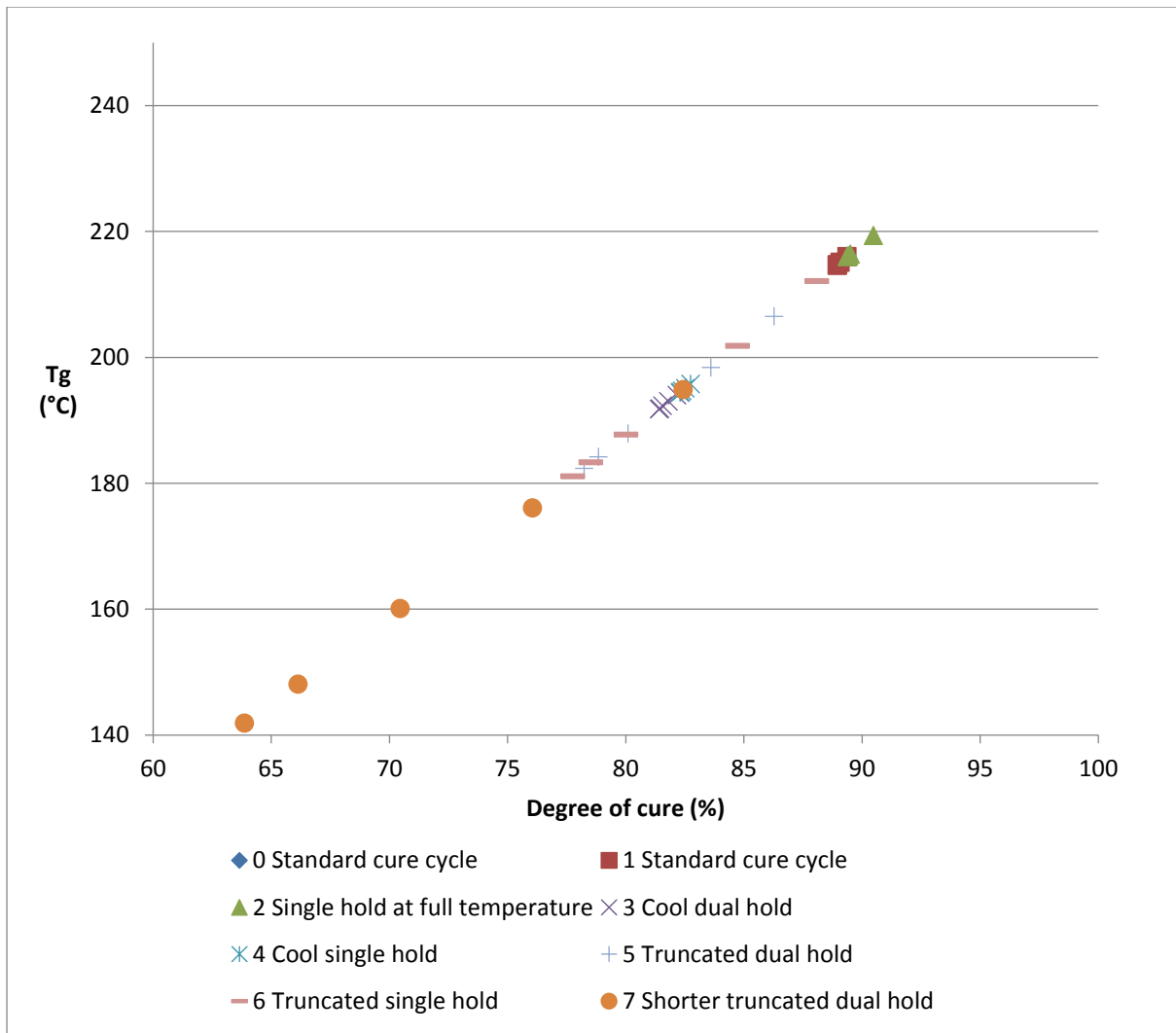

Figure 5.33:  $T_g$  - degree of cure relationship from Raven simulations based on thermocouple data.

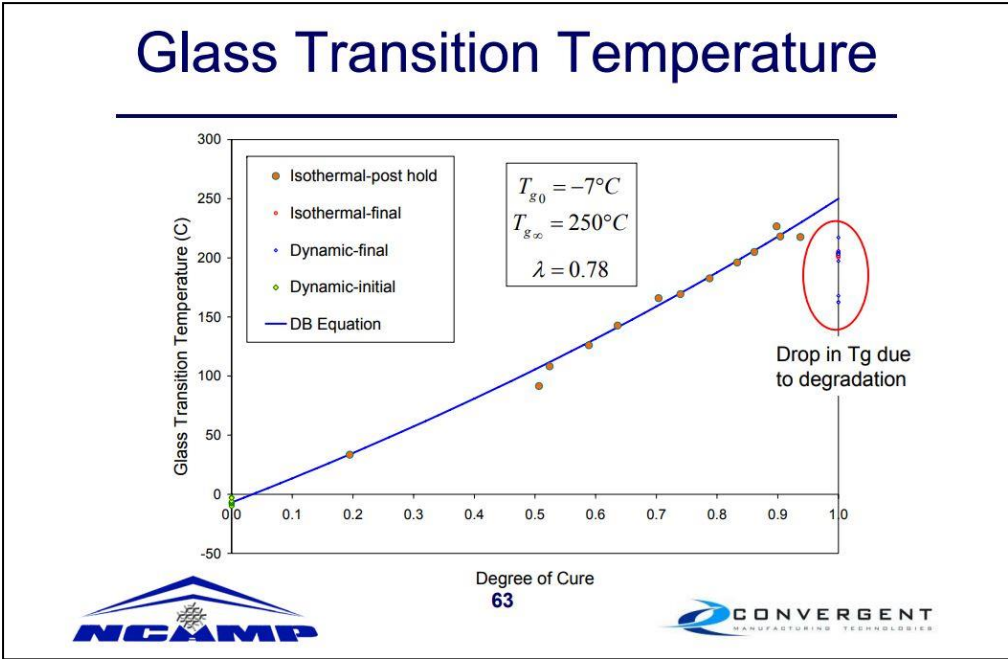

Figure 5.34: The study used to develop the NCAMP model shows that the drop in  $T_g$  at high degree of cure due to degradation is not included in this model. Reproduced from [23]

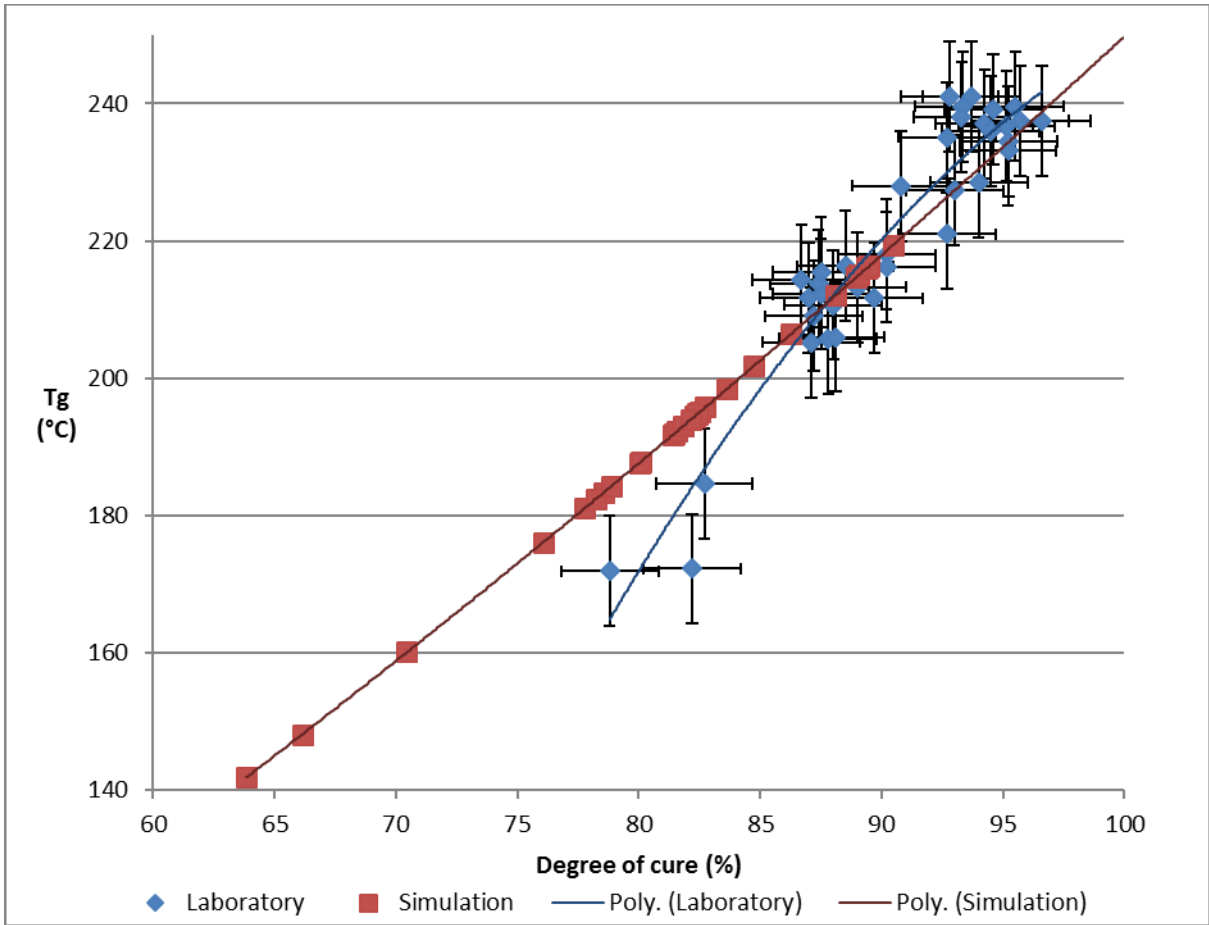

Figure 5.35: Laboratory and simulation based on thermocouple data results for  $T_g$  - degree of cure relationship, disregarding laboratory results showing  $T_g$  degradation and anomalies. 2<sup>nd</sup> order polynomial trendlines.

The model- even after the suggested correction- can be considered a reasonable approximation to reality only in the range indicated by the two clusters of results on the graph. At a lower degree of cure the results curve below the trendline, as shown by cure cycle 7, and at a higher degree of cure degradation takes place, which is not included in the model. The divergence of the two trendlines at the upper cluster suggests that there may also be a difference between reality and the model trendline here, but experimental error means this cannot be stated with certainty.

#### *Advise DETA Dielectric Cure monitoring*

The flexible dielectric sensors (DEA) for the Advise DETA system were embedded into the vertical centre of the thin and thick extremes of each part- step 1 and step 5. The system uses the same NCAMP material model as that used in the Raven simulations [23], [44], but has a different implementation, using the signal from the dielectric sensor to calculate degree of cure based on the imaginary impedance maximum (similar to [105], model is proprietary), then relating this to  $T_g$  using the DiBenedetto relationship from the NCAMP model[23].

Conductivity, degree of cure and  $T_g$  signals from the two channels currently available are sent at each timestep to the autoclave control PC and can be used in programming the autoclave. The truncated cure cycles (5 and 6) were programmed to move to the cool down segment when both sensors, at both extremes of part thickness, showed 85% degree of cure or higher.

In the first attempt at doing this on a dual hold cycle, the sensor in the thin end of the wedge failed, meaning the autoclave was moved to cool down when only the thick end had reached the required 85% degree of cure. This was recorded as cure cycle 7, for comparison to the successful cure cycles 5 and 6 carried out afterwards. Therefore cure cycle 7 has no thin end DEA measurement of  $T_g$  or degree of cure.

The sensors can track these properties throughout the cure, but for comparison to laboratory tests and simulation, only the final measurements of  $T_g$  and degree of cure by the DEA sensors are used.

The error on  $T_g$ , stated by the manufacturer, is  $\pm 5^\circ\text{C}$  and the error on degree of cure, again according to the manufacturer, is  $\pm 0.02$  (i.e.  $\pm 2\%$  degree of cure).

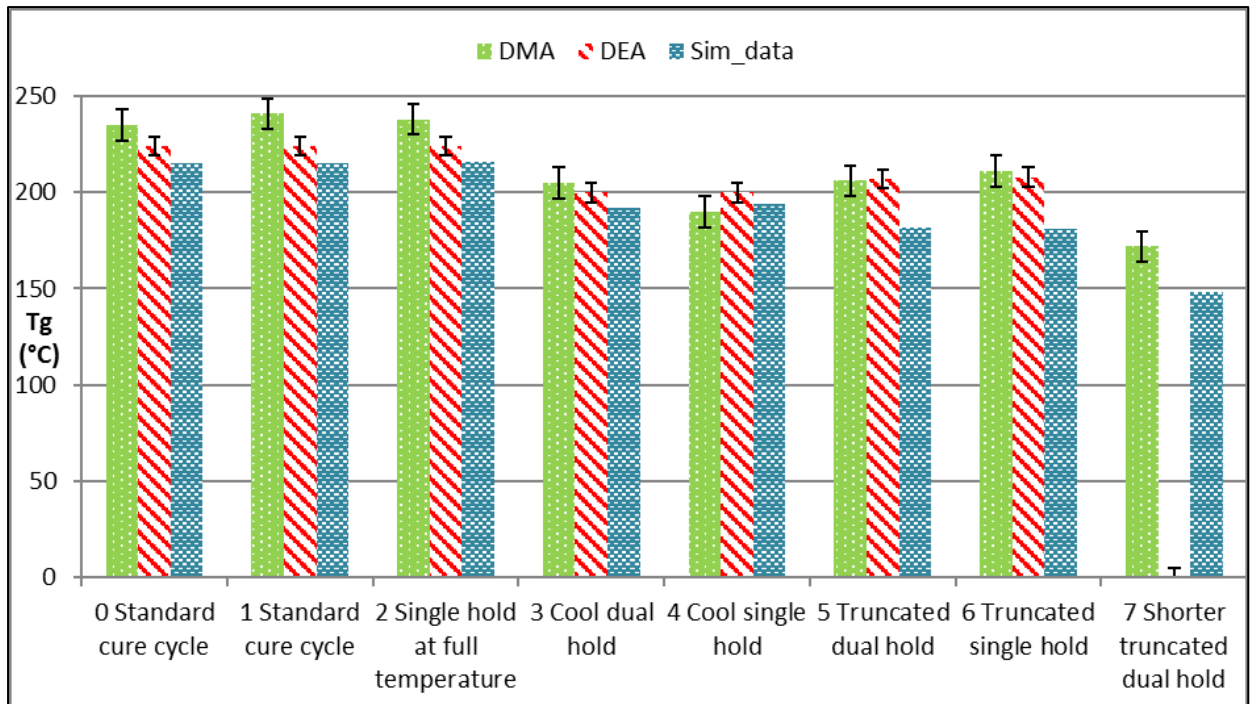

Figure 5.36: Comparison of  $T_g$  measurements for the thin end of the wedge (Step 1) for each cure cycle. Error bars are  $\pm 8^\circ\text{C}$  for DMA and  $\pm 5^\circ\text{C}$  for DEA. Note that the DMA measurement for cure cycle 4 is anomalous, here the DEA measurement is noticeably higher than the DMA measurement.

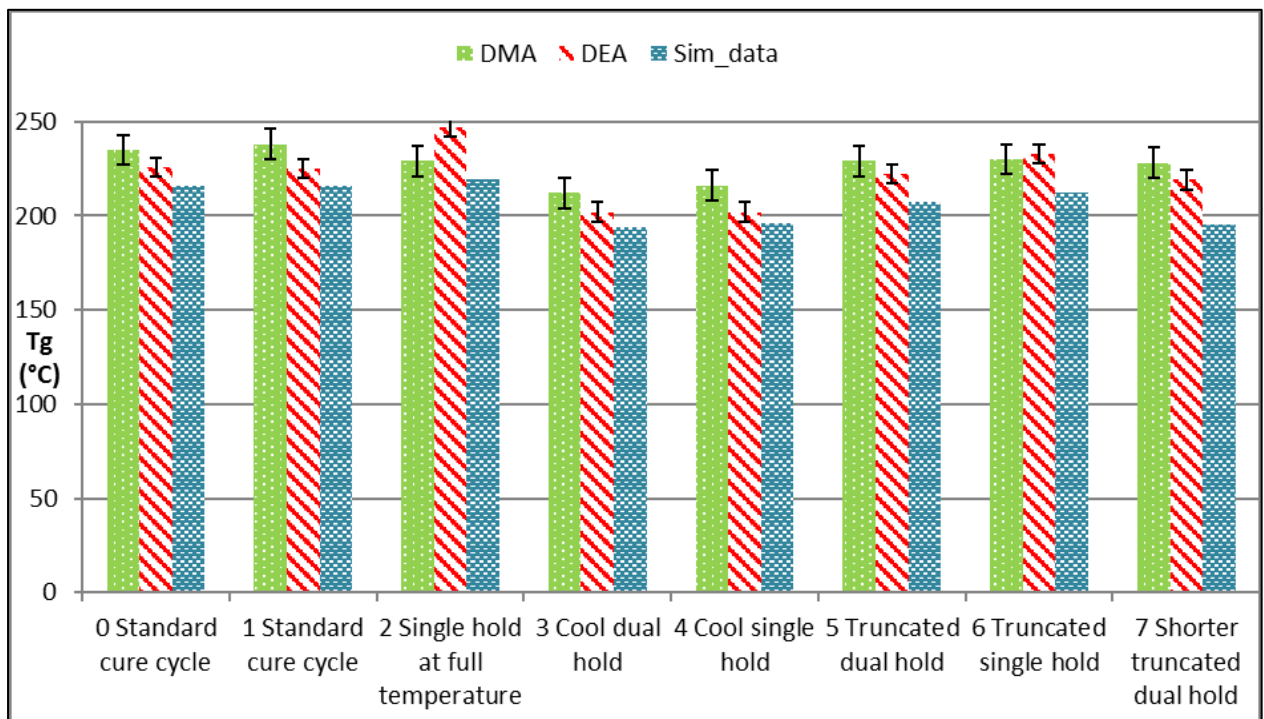

Figure 5.37: Comparison of  $T_g$  measurements for the thick end of the wedge (Step 5) for each cure. Error bars are  $\pm 8^\circ\text{C}$  for DMA and  $\pm 5^\circ\text{C}$  for DEA. The two full temperature single hold cures, where step 5 experienced  $T_g$  degradation, are the only cases where the DEA measurement exceeds the DMA measurement.

Figure 5.36 and Figure 5.37 show that in most cases the Advise DETA measurements of  $T_g$  are within experimental error of those obtained by DMA.

$T_g$ (°C)						
Cure cycle	Step 1			Step 5		
	DMA ±8°C	DEA ±5°C	Sim_ data	DMA ±8°C	DEA ±5°C	Sim_ data
<b>0) Recommended</b>	235	224	215	235	226	216
<b>1) Recommended repeat</b>	241	224	215	238	225	216
<b>2) Single hold</b>	238	224	216	229	247	219
<b>3) 2 hold cool</b>	205	200	192	212	202	194
<b>4) 1 hold cool</b>	-	200	194	216	202	196
<b>5) 2 holds truncated</b>	206	207	182	229	222	207
<b>6) 1 hold truncated</b>	211	208	181	230	233	212
<b>7) 2 holds over-truncated</b>	172	-	148	228	219	195

Table 5.9: Comparison of  $T_g$  results from DMA, DEA and Raven simulation based on thermocouple data.

The repeat of cure cycle 1, where the DMA measurement is notably higher than the first run ('0') is outside experimental error on the thin end by 4°C and cure cycle 4 is outside experimental error on the thick end by 1°C, though both follow the general trend, shown by almost all of the data points, of the DMA measurements being slightly higher than the DEA.

The DEA measurement of  $T_g$  is higher than the DMA measurement in Step 5 (thick extreme) for cure cycles 2 and 6, both of which are single holds at 180°C. As seen in the previous section, here there is a large exotherm and the step reaches a very high degree of cure, consequently some degradation in  $T_g$  is expected. The NCAMP model does not allow for this and the Advise implementation of it does not seem to have changed that.

### Degree of cure (%)

Cure cycle	Step 1			Step 5		
	DSC ±2%	DEA ±2%	Sim_ data	DSC ±2%	DEA ±2%	Sim_ data
<b>0) Recommended</b>	93	92	89	95	93	89
<b>1) Recommended repeat</b>	93	92	89	97	92	89
<b>2) Single hold</b>	96	92	89	99	99	90
<b>3) 2 hold cool</b>	87	84	81	88	85	82
<b>4) 1 hold cool</b>	86	84	82	88	85	83
<b>5) 2 holds truncated</b>	88	87	78	94	91	86
<b>6) 1 hold truncated</b>	88	87	78	99	95	88
<b>7) 2 holds over-truncated</b>	79	-	66	91	90	82

Table 5.10: Degree of cure results from DSC, DEA and Raven simulation based on thermocouple data

The Advise DETA measurements of degree of cure are almost all within experimental error of those found by DSC, with the DEA degree of cure tending to be slightly lower. This can be seen in Figure 5.38 and Figure 5.39 for the thin and thick ends of the wedges respectively.

This is no bad thing where the degree of cure from the DEA system is used to control the autoclave, as if the sensor slightly underestimates, we can be confident that the part has achieved the required degree of cure- even more so when the extra cure during cooldown is taken into account.

The only point not within experimental error is step 5, the thick end of the wedge, for the repeat of the recommended cure cycle (1), where the difference is 5%. There is of course no point of comparison at the thin end for cure cycle 7.



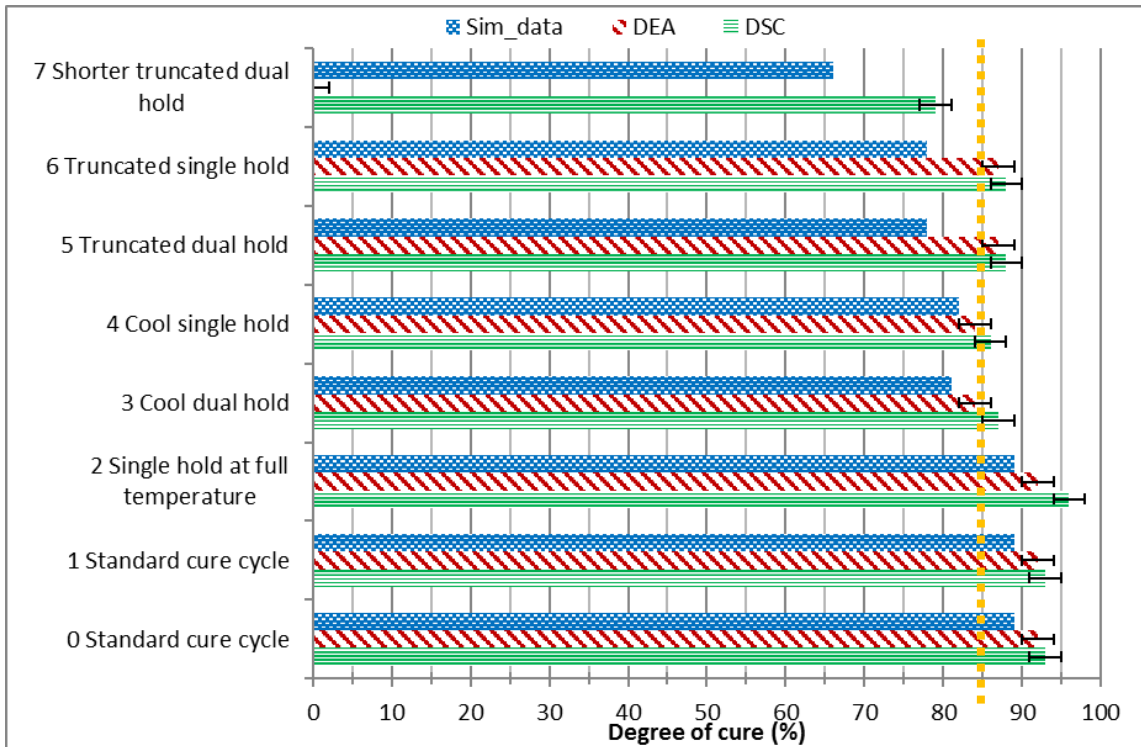

Figure 5.38: Comparison of degree of cure measurements for the thin end of the wedge (Step 1) for each cure cycle. Error bars are  $\pm 2\%$  for DSC and  $\pm 2\%$  for DEA. The target of 85% degree of cure is marked in yellow.

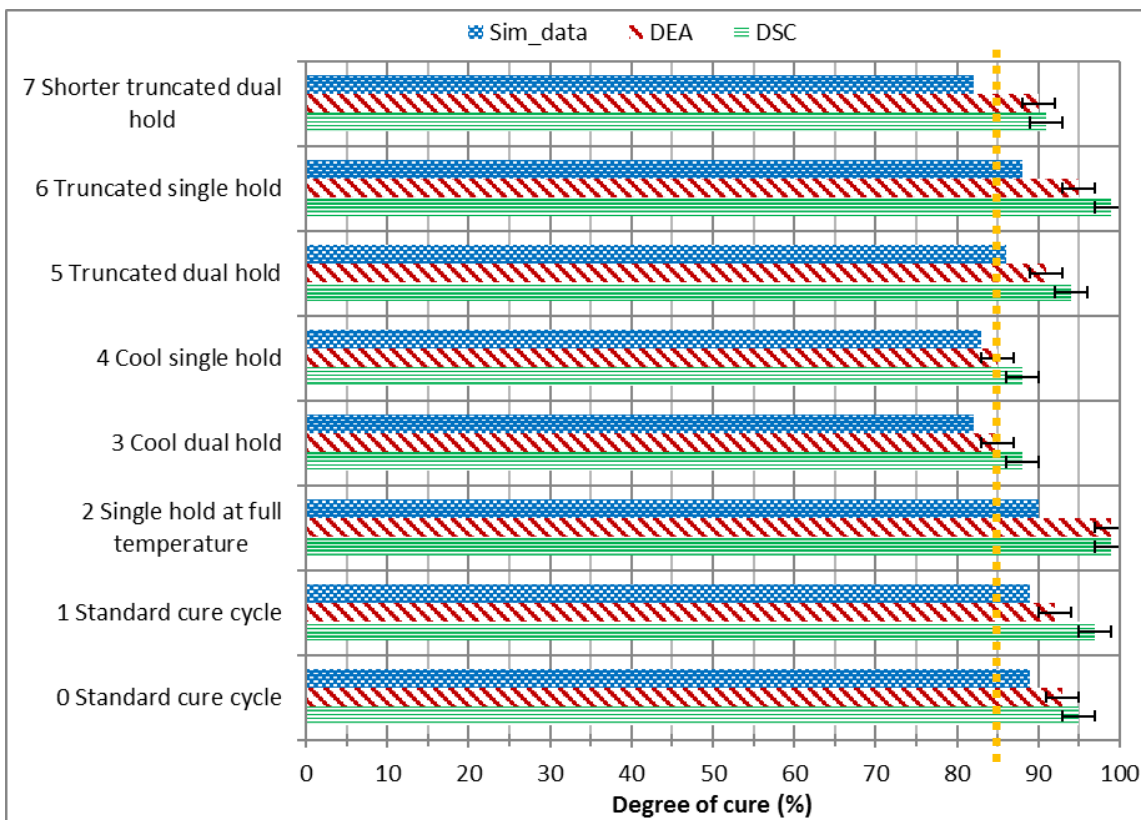

Figure 5.39: Comparison of degree of cure measurements for the thick end of the wedge (Step 5) for each cure cycle. Error bars are  $\pm 2\%$  for DSC and  $\pm 2\%$  for DEA. The target of 85% degree of cure is marked in yellow.

Output of the DEA sensors over a full cure cycle can also be compared to that from the Raven simulations based on thermocouple data. Figure 5.40 shows this for the manufacturer’s recommended cure cycle. The DEA sensor output gives a higher degree of cure than the simulation throughout, but when the DEA signal has levelled off, the Raven simulation continues to climb slightly for a little longer before levelling off at a lower figure. The difference between the final values of degree of cure from DEA and Sim\_data is hence greater for truncated cure cycles at the thin end of the wedge. As both the DEA system and Sim\_data Raven simulation relate  $T_g$  to degree of cure using the NCAMP model [23], the former follows the same trend as the latter.

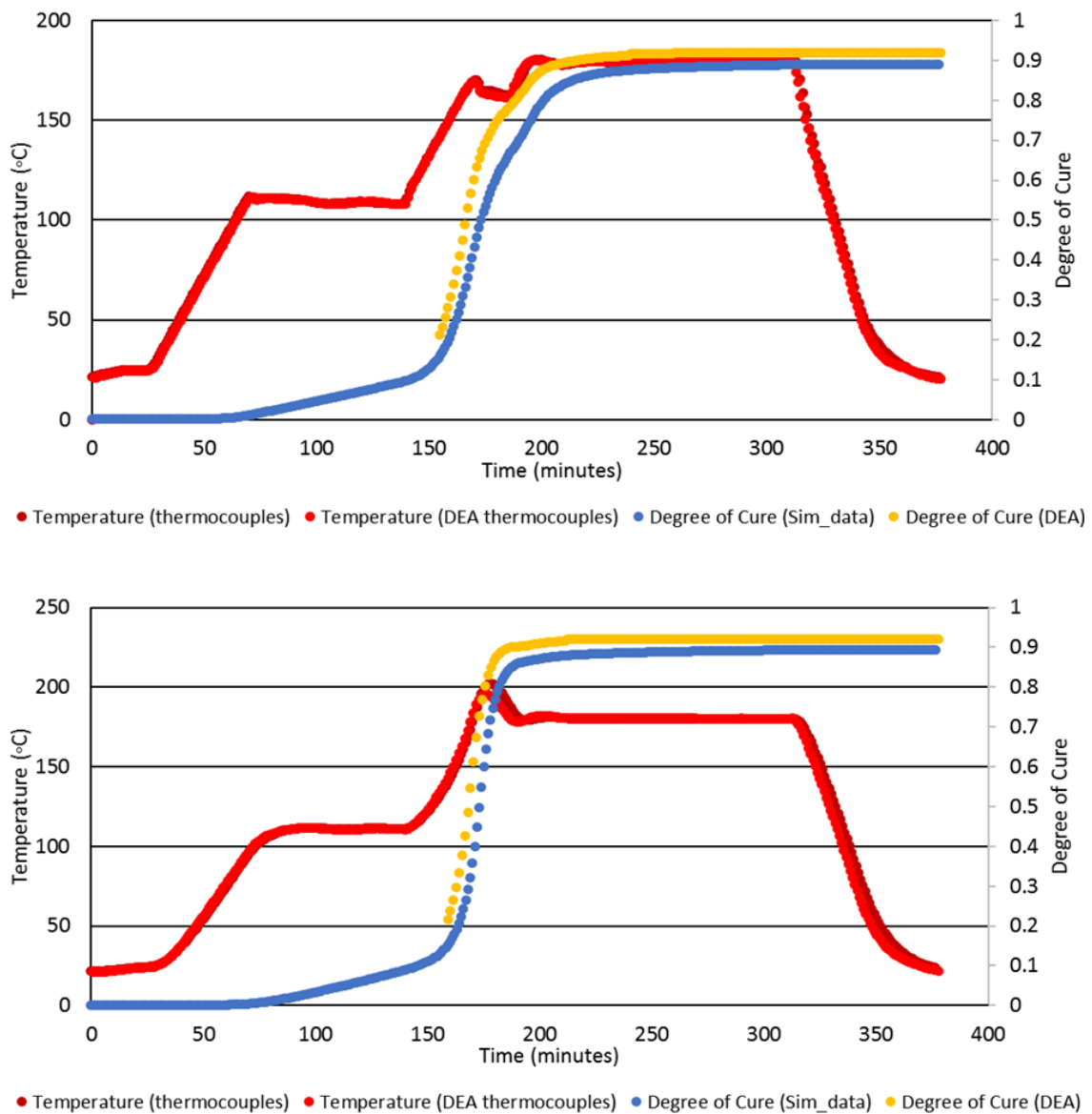

Figure 5.40: Comparison of degree of cure data for the thin (upper) and thick (lower) ends of the stepped wedge throughout the manufacturer’s recommended cure cycle. Temperature measurements in red, data from DEA sensors in yellow, simulation based on thermocouple measurements in blue.

Plotting  $T_g$  vs degree of cure, as for Sim\_data, in Figure 5.41 shows the DEA results follow the same trendline as the simulations, as expected given the shared DiBenedetto equation from the NCAMP model. However, the DEA results are far closer to those obtained by the laboratory tests. A smaller correction of approximately 2% degree of cure and 12°C  $T_g$  would bring the majority of DEA results in line with the DMA tests, and even without this most are within experimental error.

This supports the assertion that the difference between the Raven Sim\_data results based on the real thermal history of the part and the laboratory DMA and DSC results is likely due to the cure kinetics component of the model rather than the  $T_g$ -degree of cure relationship, as this  $T_g$ -degree of cure relationship is the same for the DEA results, but the DEA system initially calculates degree of cure based on the dielectric sensor signal (as discussed in Chapter 2).

It is unfortunate that due to a sensor failure there is no point of comparison for the lower degree of cure and  $T_g$  results, from cure cycle 7. It seems likely that if the trendline is followed the DEA results would be inaccurate in this region, but this cannot be determined without further testing.

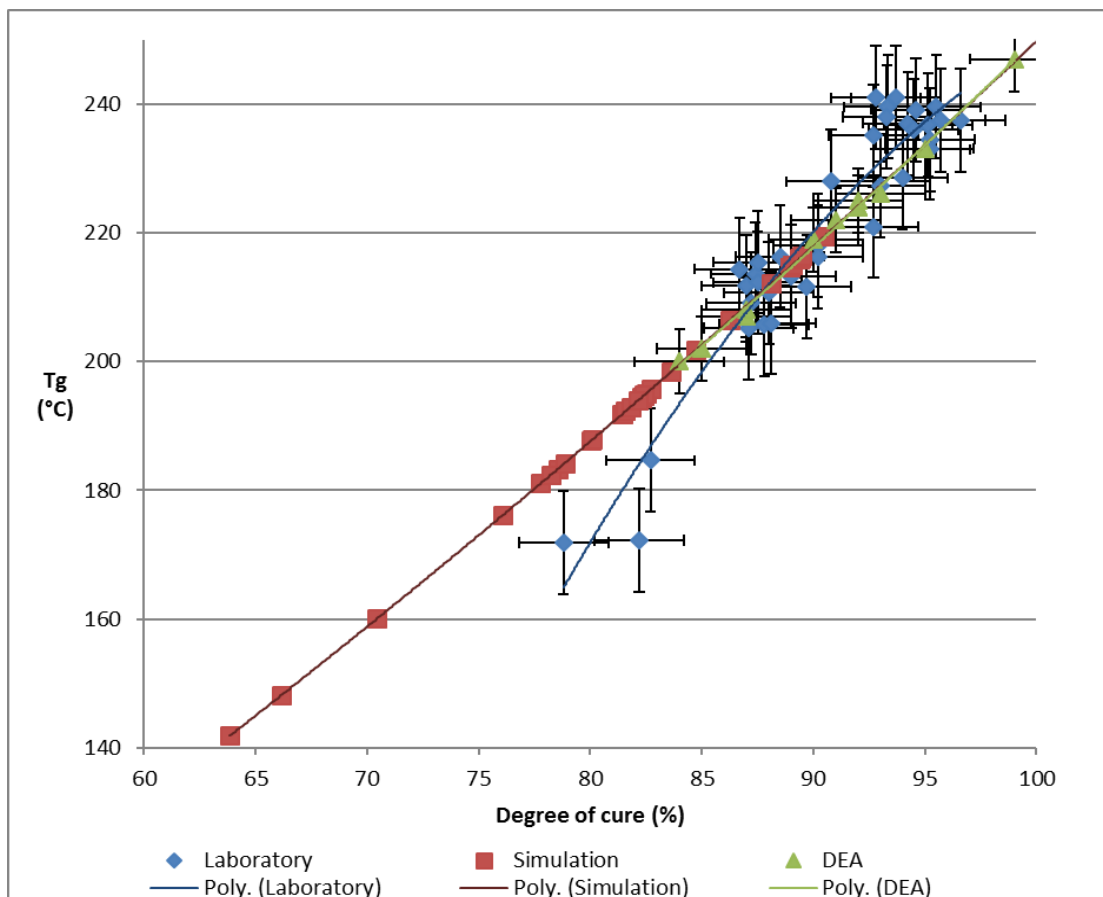

Figure 5.41: Comparison of DEA sensor results to laboratory DMA and DSC tests and Raven simulations based on thermocouple data, following Figure 5.35. The laboratory results showing  $T_g$  degradation and those which are anomalously low  $T_g$  are not included. The uppermost DEA result is the equivalent of one of these where the laboratory results show degradation.

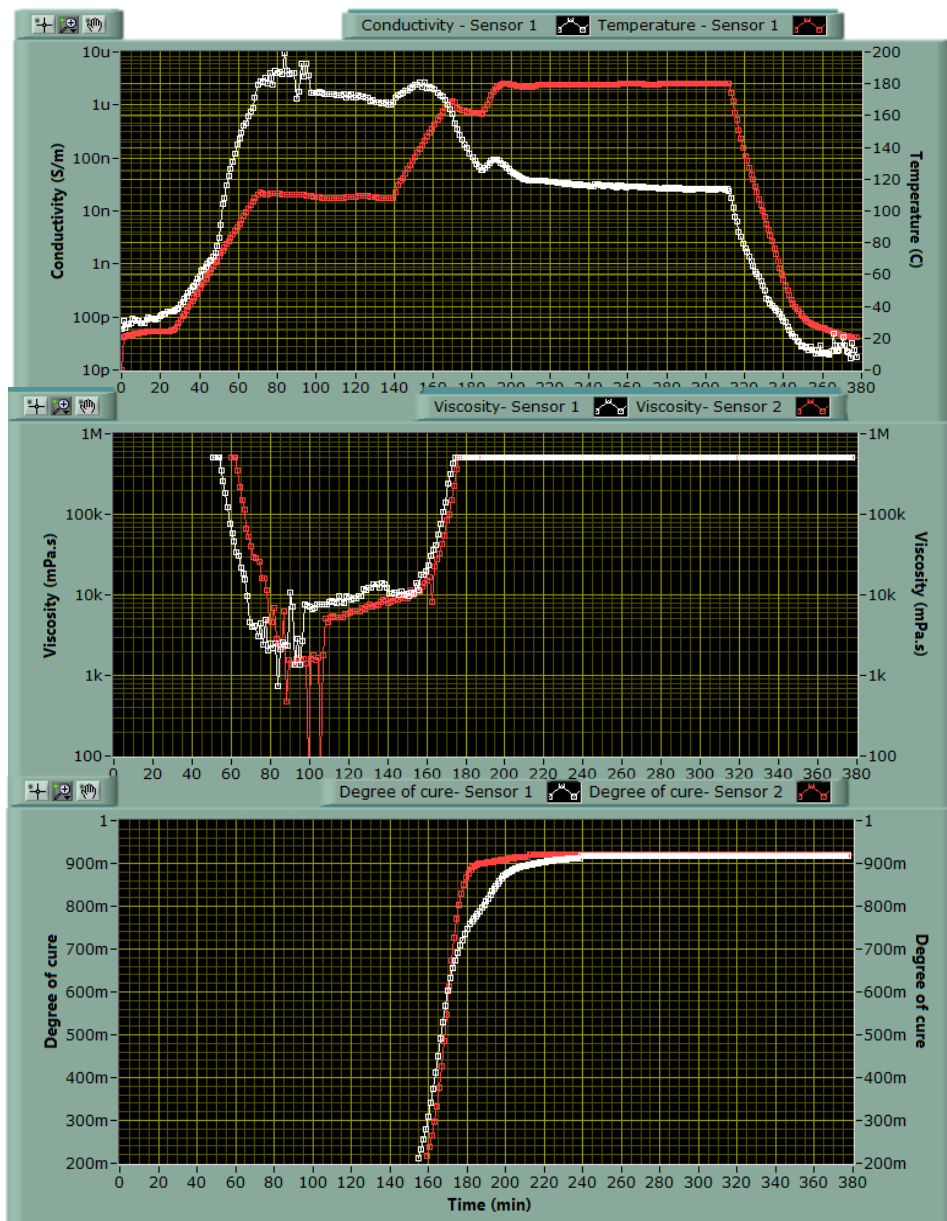

Figure 5.42: Output from Advise DETA system for cure cycle 1. The top pane shows conductivity (white) and temperature (red) in step 1. The middle pane shows viscosity in step 1 (white) and step 5 (red). The lower pane shows degree of cure in step 1 (white) and step 5 (red).

The resin viscosity output from the Advise DETA system indicates when gelation takes place. In Figure 5.42, when the viscosity reaches the maximum signal and levels out, gelation has occurred. If this model is accurate, even on the standard, manufacturer recommended cure cycle, gelation occurs near the top of the ramp to the second hold- during the exotherm for the thick end of the part and as the autoclave cools to control said exotherm for the thin end. This may lead to different thermal stresses being present in the two extremes, for they gel at the same time but at significantly different temperatures. This effect is further exaggerated in a single hold cycle.

Figure 5.42 also shows the evolution of degree of cure during this cure cycle. It is notable that, while 85% degree of cure was chosen as the target for this study in order to obtain a range of results, if a higher degree of cure is required there is still scope to shorten the cure cycle considerably. Degree of cure in both sensors levels off- meaning any remaining increases are too small to be detected- with over an hour remaining in the second hold. This suggests that even where 85% degree of cure is not sufficient, there is nevertheless scope for shortening the cure cycle and delivering energy and time savings.

*Synthesites Optimold DC Cure monitoring*

The Synthesites system used a modified pass-through originally intended for a second Advise installation. Therefore, the cables used are not the correct specification for the Optimold equipment- for example, the Advise equipment uses a type K thermocouple, while the Optimold equipment does not, so the temperature readings are offset from reality, as can be seen in Figure 5.43. The temperature data from the autoclave thermocouples were provided to the Synthesites team along with the sensor data, in order to compensate for this.

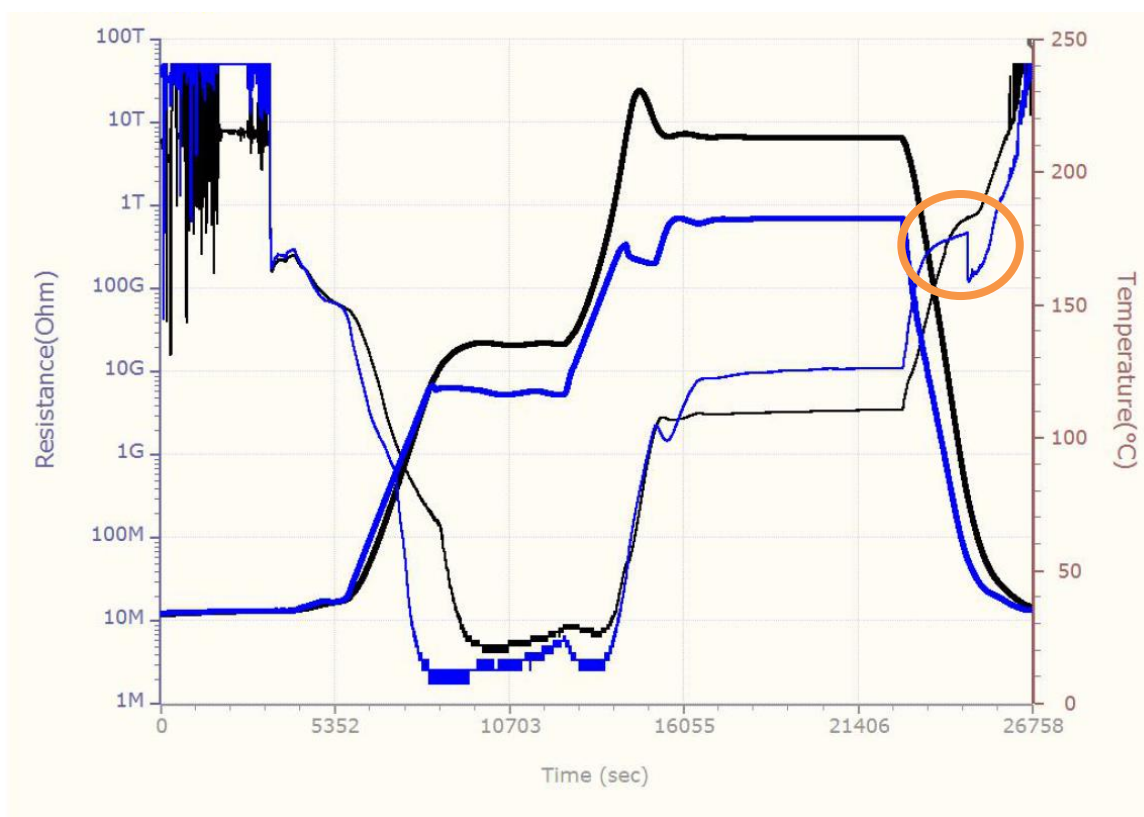

Figure 5.43: Optimold DC sensor output for cure cycle 1. The thick lines represent temperature and the thin lines resistance. The offset in temperature can clearly be seen here- the first hold is at 110°C for both ends of the wedge, and the second at 180°C, again for both ends. The orange highlight shows a feature which the Synthesites model for this resin currently cannot fit, shown more clearly in Figure 5.45.

Synthesites have provided estimates of  $T_g$  from the sensor readings and temperature data from the Type J thermocouples, based on the same NCAMP material model used for the Raven simulations, though using their own method. Figure 5.44 is an example of this.

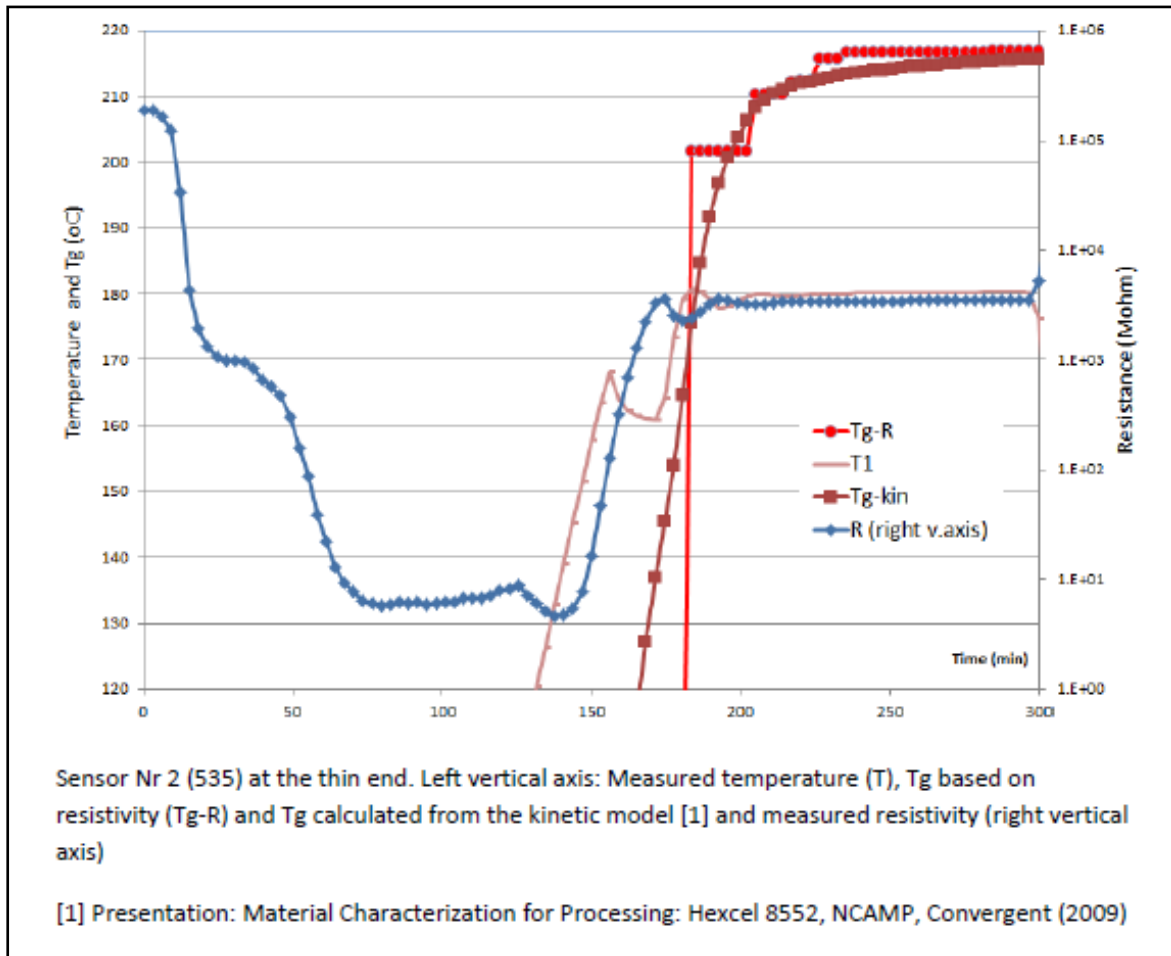

Figure 5.44: Illustration of  $T_g$  estimate provided by Synthesites, in this case for cure 0 at the thin end.

Estimates for degree of cure were not provided, but since the NCAMP model is used, these could in principle be estimated using the  $T_g$  -degree of cure relationship from that model, as used in both the Advise DETA and Raven cases. They have not been able to provide  $T_g$  estimates for all the cures, but have been given a sample of the material and the DSC and DMA results from this experiment so that they may refine their model for future use.

Synthesites declined to provide estimates for the truncated cures (5-7) as some of the results showed a feature inconsistent with their model for the resin, highlighted in Figure 5.45. Later inspection showed that this feature can also be identified, though far smaller and less distinct, in some of the other results, including cure cycle 1, as shown in Figure 5.43.

$T_g$ (°C)								
	Step 1				Step 5			
Cure cycle	DMA ±8°C	DEA ±5°C	DC	Sim_ data	DMA ±8°C	DEA ±5°C	DC	Sim_ data
<b>0) Recommended</b>	235	224	217	215	235	226	217	216
<b>1) Recommended repeat</b>	241	224	215	215	238	225	218	216
<b>2) Single hold</b>	238	224	207	216	229	247	208	219
<b>3) 2 hold cool</b>	205	200	193	192	212	202	196	194
<b>4) 1 hold cool</b>	-	200	197	194	216	202	198	196
<b>5) 2 holds truncated</b>	206	207	-	182	229	222	-	207
<b>6) 1 hold truncated</b>	211	208	-	181	230	233	-	212
<b>7) 2 holds over-truncated</b>	172	-	-	148	228	219	-	195

Table 5.11: Table of results comparing  $T_g$  estimates by DMA, DEA, DC sensors (Optimold) and Raven simulation based on thermocouple data. Synthesites did not supply an indication of the error on their  $T_g$  estimate.

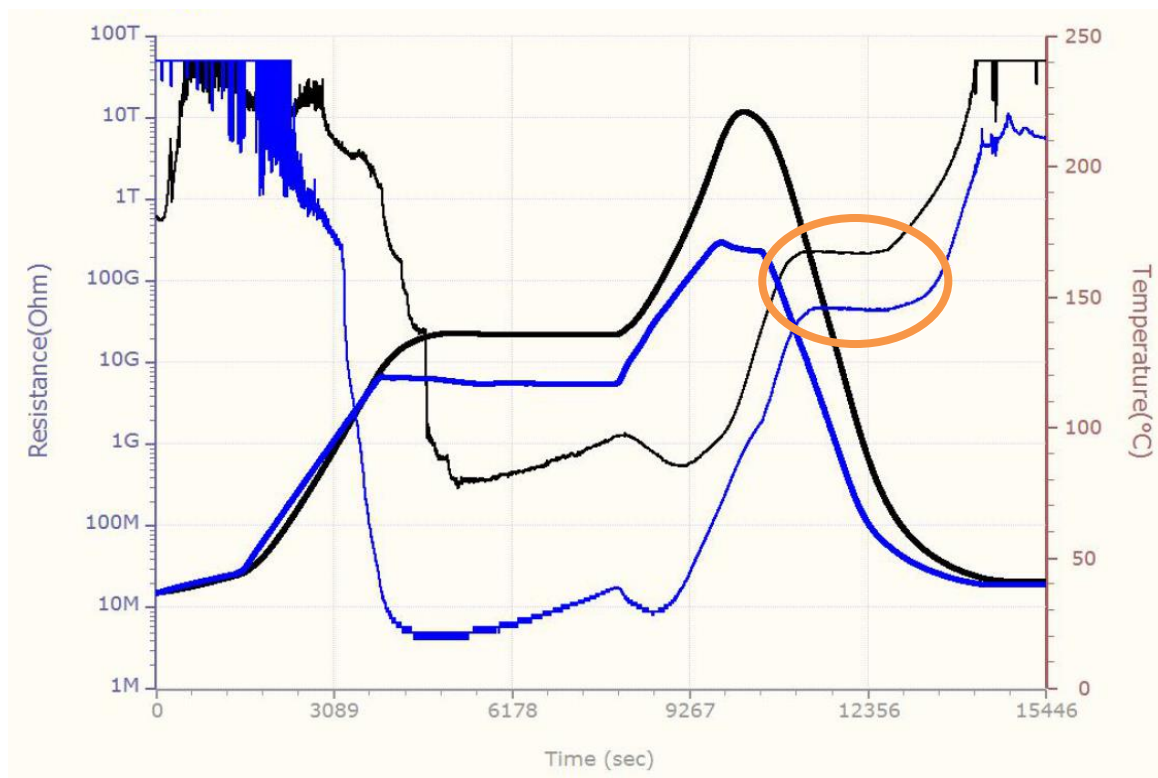

Figure 5.45: Optimold sensor outputs for cure cycle 7. The thick lines denote temperature and the thin lines denote resistance. Note the offset between the temperature measurements, these are not correct, but can be corrected in post-processing. However, Synthesites indicated that the plateau in the resistance lines (highlighted in orange) cannot be fitted to their model.



Both the connections for the sensors and the model used to calculate  $T_g$  therefore must be seen as unreliable at this stage. For these reasons, the Optimold data should be regarded with caution, though these problems can in principle be overcome for future trials through use of a new pass-through and production of a full model for the resin system. It is however possible to qualitatively assess the usability of the system.

#### 5.7.3.2 *Practicalities and ease of use*

##### *Integration of sensors with autoclave*

Where an autoclave has been constructed with pass-throughs to allow addition of sensors, the addition of the sensor cables and connection points can be relatively straightforward. The inner and outer covers of the pass-through are removed, with the outer cover replaced with an appropriately pressure sealed plate with embedded connectors for the cables. Inside the autoclave, heat and pressure suitable cables pass to connection boxes easily added to the inner wall. The connections between the cables and sockets in this box are however a weak point and have been known to fail.

Should the autoclave not be designed to allow this, it is still possible to add such sensors but is much more difficult, and likely to be more expensive.

The Synthesites Optimold results demonstrate the importance of using the correct cables for the sensor system. Swapping from one system to another is not a simple matter of rewiring the end points to accept different cables.

The physical cable setup needs to cope with not only heat and pressure but also vibration, which can contribute to loosening of connections both inside and outside the autoclave.

Once the connection was set up, using the Advise DETA sensor signals as autoclave control parameters functioned as well as any other built in sensor, such as the integrated thermocouples. However, the monitoring software for both sensor systems is still run through a separate PC at present. It is not known whether or not either system's monitoring software could be fully integrated with the autoclave PC. The setup however required work by both the software and autoclave manufacturers.



### *Usage for cure monitoring*

In an industrial environment, equipment is expected to be ruggedised in order to cope with repeated heavy usage. While cables running through an autoclave wall and a port can be set up in a suitable manner, the connections from the socket box to the flexible sensor, and the sensors themselves, are somewhat delicate.

The Optimold flexible sensors must be manually wired into a connector each time they are used, a process too intricate and time consuming for repeated use in an industrial environment.

The flexible sensors used in the DETA-scope system slot into a small, delicate electronics connector, housed in a protective cover made from a PEEK rod. These connectors are very easily damaged, as shown in Figure 5.46. As manipulation of a very small item is required, it would not be possible to connect these sensors while wearing heavy gloves.

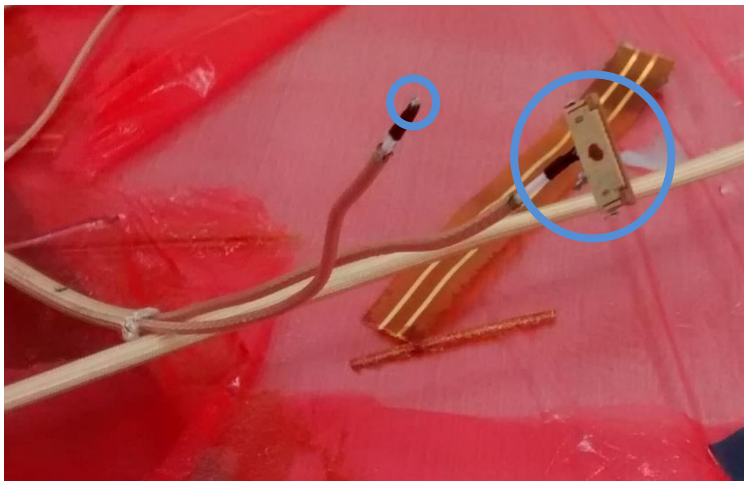

Figure 5.46: Damaged electrical connector for an Advise DETA-Scope flexible connector. Approximately 1cm in width. Connector and disconnected wire circled in blue. Here the solder has given way when the sensor was removed. In the background, a GIA sensor which has absorbed resin can be seen.



Figure 5.47: Protective cover for connector, with flexible sensor attached. Sensor ~1cm wide.

The connection protectors, shown in Figure 5.47, are also somewhat intricate and would be very difficult to handle while wearing protective gloves of the sort often used in industry.

The sensors themselves are delicate and can easily fail.

The software for the Advise DETA-Scope is Labview based and provides a lot of information- while valuable, this is enough to be overwhelming to the inexperienced user. A simplified interface would be useful. It does include an option to check sensor connections before proceeding with a cure, which is useful.

The Synthesites Optimold software is simpler to use and data collection can easily be stopped and restarted prior to the cure for sensor checking.

#### *Usage for active process control*

Only the Advise DETA-Scope system has been tested for active process control. Connected to the ASC autoclave control system, the autoclave side is as easy to use as any other aspect of the autoclave programming software. The DETA-Scope side however required some bespoke software creation by the manufacturer which, while sufficient to do the job, would benefit from being integrated with the main dielectric monitoring software- or better yet, a simplified version of the same.

In the long run a full integration where both dielectric monitoring and autoclave control could take place through the same interface on the same PC would be ideal, but this depends on both software and corporate compatibility.

### 5.7.4 Energy and Cost

Table 5.12 shows the energy usage for each of the cures, and an estimate of the cost based on an electricity cost of 12p+VAT=14.4p per kWh. [226]

Comparative figures for the equivalent carbon dioxide (CO<sub>2</sub>) emission (CO<sub>2\_e</sub>, kg) and the number of miles an average petrol car would drive for that amount of CO<sub>2</sub> emission (Car miles) are based on the Carbon Trust's conversion factors [14].

Cure	Energy (kWh)	Cost (£)	CO <sub>2_e</sub> (kg)	Car miles	Step 1 T <sub>g</sub> (±8°C)	Step 5 T <sub>g</sub> (±8°C)	Step 1 deg cure (±2%)	Step 5 deg cure (±2%)
0	180	26	95	282	235	235	93	95
1	175	25	92	273	241	238	93	97
2	184	26	96	287	238	229	96	99
3	164	24	86	255	205	212	87	88
4	156	23	82	244		216	86	88
5	129	19	67	201	206	229	88	94
6	110	16	58	172	211	230	88	99
7	135	19	71	211	172	228	79	91

Table 5.12: Energy usage, cost, equivalent carbon dioxide emission and equivalent miles that can be driven in a standard petrol car for that amount of emission, for each cure cycle. T<sub>g</sub> values are as measured by DMA tan δ peak and degree of cure values are as measured by DSC. The suggested optimum cure cycle of these options, 6, is highlighted in green and the recommended cure cycle, 0, is highlighted in cyan for comparison.

	Cycle	Ramp to	Hold	Ramp to	Hold	Ramp to	End
0	Recommended	110°C	1 hour	180°C	2 hours	60°C	Purge
1	Recommended	110°C	1 hour	180°C	2 hours	60°C	Purge
2	Single hold	180°C	3 hours	-	-	60°C	Purge
3	2 hold cool	110°C	1 hour	160°C	2 hours	60°C	Purge
4	1 hold cool	160°C	3 hours	-	-	60°C	Purge
5	2 hold DEA triggered	110°C	1 hour	180°C	85% cured	60°C	Purge
6	1 hold DEA triggered	180°C	85% cured	-	-	60°C	Purge
7	2 hold over-truncated	110°C	1 hour	180°C	85% step5	60°C	Purge

Table 5.13: Cure cycles, for reference.

As the thin end of the wedge did not reach 85% degree of cure during the shorter truncated dual hold, this is not considered an option. So for the case where the part requires 85% degree of cure and a  $T_g$  of  $211\pm 8^\circ\text{C}$  at the thin end and  $230\pm 8^\circ\text{C}$  at the thick end is sufficient, it is possible to save *per cure* approximately 71kWh, the equivalent of 37kg of  $\text{CO}_2$  emission or 110 miles travel in a standard petrol car by using cure cycle 6, a single hold truncated, by active process control, at 85% degree of cure.

This is for a single hold cycle, where the thin end had a degree of cure of  $88\pm 2\%$  and the thick end  $99\pm 2\%$ , according to DMA measurements. Perhaps surprisingly, the truncated dual hold resulted in a greater gap in glass transition temperatures between the thin and thick ends, with the thin end only reaching  $206\pm 8^\circ\text{C}$  and the thick end reaching  $229\pm 8^\circ\text{C}$ .

The realistic savings depend on the requirements for the part and the equipment and rate of production at the factory. For this theoretical case, a factory running 2 cures per day, 5 days per week could over a year save approximately £5,300 and 19,300kg  $\text{CO}_2_e$ , or for 3 cures per day, 7 days per week, £11,100 and 40,400kg  $\text{CO}_2_e$ .

It must be noted again that this is an example only and may not reflect reality, where factors including the part design; material chosen; requirements for the in-service part or parts (if there is a mixed load in the autoclave); the number of parts cured simultaneously; choice of cure method and efficiency of equipment will all have an impact. A business may of course choose instead to increase production if the cures are shorter, if the other production activities required allow this to happen.

We know from the dielectric cure monitoring that even if a higher degree of cure is required, there is the potential to shorten the cure cycle significantly for this particular material. Note too that part thickness makes a difference- for the cheapest qualifying cure cycle, number 6, steps 2 and 3 achieved  $90\pm 2\%$  degree of cure and step 4 achieved  $93\pm 2\%$ .

The suitability of such truncated cure cycles depends on the part and the application for which it is intended. Mechanical properties, not studied here, would need to be checked for any suggested optimised cure cycle to ensure they reach the necessary requirements for the job.

## 5.8 Conclusions and Future Work

The two cure monitoring technologies both show promise, but neither is yet fully ready for use in an industrial environment. However, the results shown here demonstrate the potential to deliver significant cost, time and energy savings in the manufacture of composite parts by autoclave.

For the material tested, Hexcel 8552, it was found that the exotherm in thick sections of the part can reach up to 38 degrees above the requested hold temperature, even with the autoclave actively cooling to control this. A single hold cure leads to a larger exotherm than a dual hold cure.

During the recommend cure cycle, it appears that the part gels just as the second hold is reached. Where there is a significant range of thicknesses in the part, this means gelation occurs at very different temperatures- the thick end is mid-exotherm while the thin end experiences cooling.

The final degree of cure appears to be reached, to the limit of detection by the Advise DETA-Scope system, with over an hour remaining in the second hold, meaning that even where high degree of cure is needed there is scope for shortening the cure cycle provided the material properties resulting are suitable for the part. Mechanical testing has not formed part of this study and would be useful in ensuring any part undergoing a non-standard cure cycle has the required properties. A repeat of this study to investigate energy savings when aiming for a higher degree of cure may be useful.

The Advise DETA-Scope system delivered estimates of degree of cure and glass transition temperature that were mostly within experimental error of those found by DSC and DMA laboratory tests. However, the degradation in  $T_g$  which occurs at high degree of cure is not included in the material model used by the Advise system.

The same material model is used in the Raven simulation software. Here results for degree of cure and  $T_g$  found from simulations based on real thermocouple data were distinctly lower than those found by the laboratory tests and DEA system, though along a trendline- that of the aforementioned model- which appears close to the laboratory results at higher degree of cure and  $T_g$ . At lower degree of cure and  $T_g$  the model may not match the laboratory results, as seen with the shortest truncated dual hold cure cycle, though the limited amount of data means this cannot be certain.

As the DEA system uses only the  $T_g$ -degree of cure relationship from the material model, calculating degree of cure based on measurements from the dielectric sensors, and delivered results mostly within experimental error of laboratory measurements, it can reasonably be suggested that the discrepancy between the Raven simulation results based on real temperature data and the laboratory and DEA results appears to stem from the cure kinetics model or implementation thereof, estimating degree of cure based on thermal history.

It should be noted that the NCAMP model for Raven was published in 2009 and refers to material bought in 2006 [44] , whereas this work was carried out in 2017. It is not known whether anything has been changed in the manufacturing of 8552 resin in that period. Further studies to determine whether the resin properties have changed and characterise variation between batches would be useful, for this work was carried out using only a single batch of material.

The real thermal profiles experienced by the test part were found to differ significantly from those predicted by a heat transfer model based on the programmed, theoretical cure cycles due to temperature control behaviour of the autoclave, which deviated from the programmed cure cycle to control the exotherm produced in the thicker steps of the wedge. Consequently these simulations are of limited use in predicting the resulting material properties.

With the exception of the shorter truncated dual hold, which occurred when a sensor failed in the thin end of a wedge for a sensor controlled cure, all the cures achieved the required 85% degree of cure. Lower temperature cures were found to deliver less variation in degree of cure and  $T_g$  among the different thickness steps of the wedge than truncated cures at the standard temperature, however the energy saving was much lower.

This work has demonstrated the potential to save money, carbon dioxide emissions and time through cure cycle optimisation, and the use of dielectric sensors in active process control, allowing the required result to be achieved automatically on the day, based on the evolution of the resin at that time, rather than relying on a theoretical model which cannot take into account variations which occur in reality such as differences between material batches or deviations from the programmed cure cycle based on autoclave safety measures. The active process control demonstrated in this work involved only automatically moving to autoclave cooling when a desired degree of cure is reached, leaving scope for far more to be done in terms of controlling the cure based on the sensor output.

# Chapter 6

## 6 Knowledge Transfer Resource for Dielectric Cure Monitoring

### 6.1 Exploring the Knowledge Transfer Resource

This chapter presents a suggestion for an industrially targeted knowledge transfer resource, to aid technology in making the leap from academia to industry. This is supplied in the form of a linked PowerPoint document, with two embedded videos. The PowerPoint file- and separate copies of the videos in case of technology incompatibility- can be found on the supplied USB memory stick, along with some of the appendices to this work.

The reader is encouraged to experience this chapter alongside exploration of the PowerPoint file, which is not linear. Should the file fail to work, the author can be contacted for a new copy. As a backup and for ease of reference, small copies of each slide are included as an appendix to this thesis - but please be aware that this printed version does not give the full effect.

### 6.2 Principles and Structure

#### 6.2.1 Preferred Knowledge Transfer Methods Among Composites Workers

Results presented in Chapter 3 show a clear preference for human-based knowledge transfer. Talking to both supervisors/line managers and other colleagues are both among the top 3 choices when searching for knowledge for the majority of people, more so for specific queries where approximately 70% of participants at SMEs, larger companies and the research institution put 'other colleagues' in their top three. Supervisors/team leaders are slightly more popular as sources of knowledge at SMEs than in larger companies, approximately 70% and 50% respectively put them in the top three choices for answering specific queries. For comparison, web search is chosen in the top 3 by 50-55% of company based participants for specific queries and 55-60% for generic queries, manuals are among the top three for 40% of company based participants for specific queries and 30% for generic queries.

There is demand for training courses, wanted by approximately 70-75% of company based participants. Taught courses which participants have experienced are considered useful only by 40-50% of participants, suggesting room for improvement. Where possible, a course delivered in person is likely to be a good option, as the demand is clearly there and it gives the opportunity to ask questions.

As taught courses in person are not always practical, or for supplementary material that can be provided after a course, videos are included in the Knowledge Transfer Resource. The videos are structured around people talking about the topic rather than voiceovers showing technology only. A person introducing something they have worked on may be able to express their enthusiasm for the topic and a human face is at least closer to interpersonal interaction than a text document.

Though it is of course no substitute for a conversation, teaching or mentoring, it is hoped that this can be used to spark discussions among colleagues or encourage interested viewers to get in touch with those working in the field. For the viewer, putting a face and voice to the work may make the idea of contacting a person to ask questions seem less daunting.

The other very popular method of knowledge transfer is web search- the interlinked document is intended to mimic web browsing and includes links to external sources. It can be hosted on a web server for online access and updated as technology changes.

Academic papers are not a popular source of knowledge in industry. The Knowledge Transfer Resource includes links to some papers both as citation of the sources of work and to encourage those who found the brief summaries interesting to read the full paper.

#### 6.2.2 Structure Based on Industrial Requirements

The structure of the resource is based in part on work by Fabris and Poursartip [115] on Knowledge in Practice Documents, notably having a section for useful scientific background and a section constructed based on an industrial approach. The latter includes the effect of the technology in question on decision making in five industrial categories: Equipment, Tooling, Part, Material and Process and Producibility. These categories were chosen based on consultation with the Composites Research Network's industrial partners, as business decisions need to be made in each area.

A Knowledge in Practice Document was written on the topic of dielectric cure monitoring by the author of this thesis, to fit with the Composites Research Network (University of British Columbia) proposed system for industrially focused knowledge transfer [115], during a secondment to that institution. Alongside decision making in each of the industrial categories, use cases for the technology are included where appropriate and case studies based on academic papers are added. This was the starting point for the PowerPoint Knowledge Transfer Resource discussed here.

The structure used here is simplified, to fit with the less textual presentation, and seeks to introduce the important points while providing links to other sources for more detail. It is intended to be easy to dip into depending on the reader's requirements rather than something to be read from start to finish. As the technology is discussed in a generic manner, there is no split by industrial sectors- it is expected that the reader will choose to view the case studies and information most relevant to her.



Emphasis is placed on demonstrating the utility of the technology and providing useful information that a company might need in order to make business decisions, such as pros and cons of different sensor types or how existing equipment may be modified to work with dielectric cure monitoring. Cost figures are not included as these are not always public and subject to change.

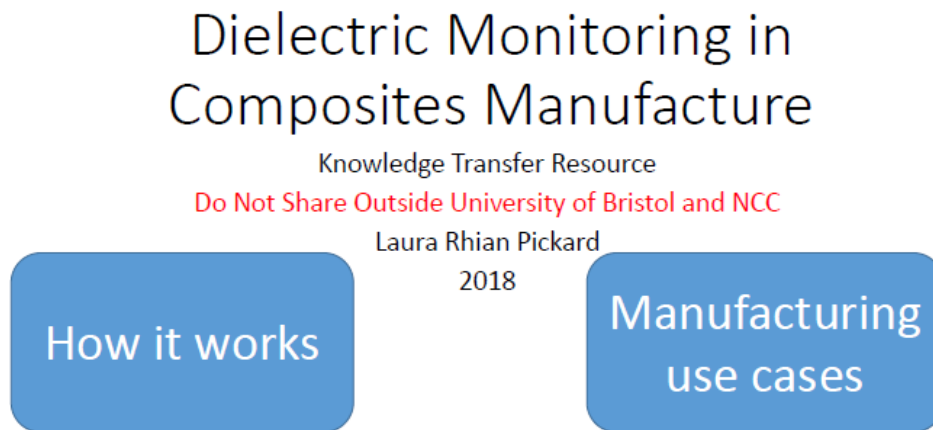

The structure of this document is based in part on the Knowledge in Practice Documents of the Composites Research Network, University of British Columbia. Content is copyright the National Composites Centre (UK) except where stated otherwise. This guide has been produced with reference to the Advise DETA dielectric monitoring system. Other systems are available.

Figure 6.1: Landing page of Knowledge Transfer Resource for Dielectric Monitoring in Composites Manufacture.

While the landing page is split into 'How it works' and 'Manufacturing use cases', as shown in Figure 6.1, these sections are interlinked where appropriate. An industrialist may not wish to read the scientific background from start to finish, but can follow links to relevant sections from the manufacturing use cases, delivering the scientific knowledge necessary to understand the decision making.

The Knowledge in Practice Document is also written in a manner which would allow an industrialist to start at the manufacturing section and look up background information where needed- but a text based document was preferred by CRN's industrial partners. It is of course possible to embed links in such a document when presented electronically.

The 'Manufacturing use cases' section includes the categories of Equipment, Tooling, Part, Materials and Processes and Producibility- alongside clear links to case studies, a video relevant to one case study and relevant external material- in this case a good practice guide and a standard, this is shown in Figure 6.2

## Use cases in Composites Manufacture

- Use cases and method requirements



- Case Studies

- [Cure Cycle Optimisation by Active Process Control](#)
- [Monitoring and Correcting for effect of Out-time on Prepreg cure](#)
- [Flow Monitoring and Control in RTM](#)



- Standard: [ASTM E2039 – 04](#) was **withdrawn** in 2009 without replacement
- NPL have issued a [good practice guide for cure monitoring](#) (2005).



Figure 6.2: Manufacturing use cases slide design showing the five industrial categories of Fabris and Poursartip [115] alongside links to case studies, a video and external references, plus a quick return to the landing page.

The ‘How it works’ section includes useful scientific background, explained briefly with minimal jargon- and links to a glossary where necessary- and links to papers for those who wish to know more. Examples from academic literature comparing the technology to other methods for measuring the same things

This section includes practical aspects of how the technology works, such as the pros and cons of different sensor types and pages of useful hints and tips based on lessons learned from working with the technology. These are linked to from appropriate areas of the manufacturing section- for example in the tooling decision making section, there is a link to tips for vacuum bagging.

### 6.2.3 Format of Knowledge Transfer Resource

The text-dominated, linear Knowledge in Practice document does not fit with the preferred methods of knowledge transfer expressed in response to the questionnaire in Chapter 3. Alternative interfaces, including PowerPoint, were briefly discussed during the secondment to the Composites Research Network, but this Knowledge Transfer Resource was developed separately.

A linked PowerPoint both fits with the popular option for web search and is more flexible than a linear document. For example a case study can include links to a relevant area in the scientific background section, equipment considerations and an external resource such as a paper. It is also easy to include a glossary, linked to from clickable, as well as multimedia elements such as video as discussed above.

# Cure Cycle Optimisation by Active Process Control

- Active autoclave control by dielectric sensors
- Sensor signal is processed and material property values (e.g. degree of cure) sent to autoclave
- Autoclave control system monitors these values and can be programmed to trigger a change in the cure cycle based on them
- In this case, when both sensors (thin and thick extremes of the part) read 85% degree of cure or more, the autoclave moves to the end of cure sequence.
- The sensor readings were [compared to laboratory tests](#) of samples from the cured wedges to verify the results.

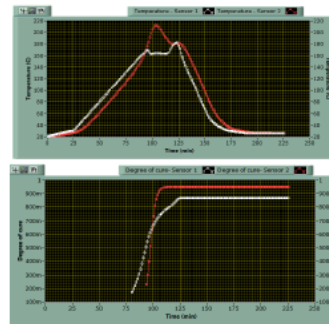

When both sensors reach 85% degree of cure (lower graph) the autoclave automatically cool down and ends the cure (upper graph)

Thesis  
Chapter 5,  
Pickard 2018



Figure 6.3: Case study slide which links to the ‘How it works’ science section (comparison to laboratory tests) and one of the relevant industrial categories (Equipment), with reference to the source (Thesis).

More emphasis is placed here on pictures and multimedia aspects, and the option to link both within the Knowledge Transfer Resource and to external sources is used to avoid repetition and guide the reader to useful material elsewhere. Text is kept minimal, to allow the reader to skim quickly over material to begin with, with the option to follow links to papers and technology manufacturer’s websites if they wish to know more.

The presentation is intended to be clear and easy to read.

## 6.3 Development of Content

Dielectric cure monitoring is a technology with the potential to benefit composites manufacturers a great deal, but very few are aware of this possibility. In order for successful technology transfer into industry to take place, practical studies are not sufficient alone- knowledge transfer is a vital part of this.

The Knowledge in Practice Document [115] written during the author’s time at the University of British Columbia was a starting point for some of the content, though it has been refined and material has been added, based on both the author’s own work, presented in Chapter 5, and relevant examples from the literature [17], [20], [24], [25], [46], [66], [86], [88], [101], [105], all of which are cited within the resource. Including comparison of the sensor output from this little-known technology to well-known laboratory tests was considered important.

Procurement of a bespoke autoclave for use with the cure monitoring systems has generated many lessons learned, which have been recorded. In a demonstration of the value of building knowledge transfer practices into business processes, this document will ultimately be of the most use when people planning future large equipment purchases can easily search for it and refer to these lessons.

Based on Chapter 3, a variety of knowledge transfer methods for Dielectric Cure Monitoring have been trialled. A two day course, delivered at NCC to an audience of EngD students and technical staff received positive informal reviews, supporting the finding that interpersonal knowledge transfer is often preferred. Material from that course was modified based on feedback and included in this Knowledge Transfer Resource.

A short introductory video, with a human presence in order to get as close to ‘interpersonal’ as possible when not delivering a course in person, has been produced and is included herein. A more

The Knowledge Transfer Resource was trialled with an audience of EngD students during an introductory course. Informal feedback was largely positive, and it was considered easy to use, though students did not follow links to external sources which explained concepts they may be unfamiliar with.

## 6.4 Conclusion

The Knowledge Transfer Resource focuses on practical, industrial applications for the technology and information that may be useful to a manufacturer of composite parts. As such, the theoretical content is limited, but links to scientific papers allow the interested reader to find out more.

A resource such as this functions best as a living document, being updated as progress is made in technology development, new research is published or in response to the needs of the composites manufacturing community. That which is presented here is a suggestion for a format, which could be applied to other topics and kept updated by a community of practice if it is considered useful.

For Dielectric Cure Monitoring in particular, a resource of this nature may be useful in enabling technology transfer from academia to industry. Results presented in Chapter 3 demonstrated that industrialists are unlikely to read academic papers, where much has been published on the topic. It is hoped that this Knowledge Transfer Resource will be of use as facilitating industrial uptake of this technology may, as demonstrated in Chapter 5 and the studies referred to in the Knowledge Transfer Resource, result in improvements in the efficiency of composites manufacture.

# Chapter 7

## 7 Discussion

This project has involved both technological development and investigation of knowledge transfer methods used in academia and industry, with the aim of delivering industrially focused cure monitoring technology presented in a manner that fits with industrial working practices.

While on first glance in-process monitoring of composites and knowledge management may seem entirely unrelated, this work demonstrates that the technology alone is not sufficient to deliver improvements in composites manufacture- it is of little use if those who could benefit from it the most remain oblivious to its potential.

Growing demand for advanced composite items, plus cost and energy saving considerations, suggest that improvements in efficiency can be of benefit to industry.

### 7.1 Knowledge Transfer Studies

If knowledge transfer between academia and industry is to be improved, it is sensible to start by finding out the current status and gathering opinions on which forms of knowledge transfer are considered most useful in the different types of organisations. This work focuses on SMEs as they are unlikely to have large research and development departments, but can have more flexibility for trialling and deploying new technology than larger companies, so connections between academia and SMEs could in principle enable technology transfer while being beneficial to both parties. The companies involved were recommended by the academic groups and research institution.

Chapter 3 reports the results of these Knowledge Transfer Studies, which apply techniques reported in knowledge management literature- detailed in Chapter 2- including knowledge networks, competence matrices and opinion questions using Likert scales and ranking items in order.

Competence matrices were modified from the standard form, with topics split into theoretical and practical- to allow for people who have practical skills but have not studied the theory, or those with a great deal of theoretical knowledge who do not often spend time in the laboratory or workshop- something Professors have been known to complain about. The results were presented with colour coding, allowing instantaneous gap analysis- if the topic is pale coloured across all staff, the organisation does not have much expertise in it.

The results of the competence matrix were also combined with knowledge networks- showing number and strength of connections for each individual below their self-rated competences, highlighting any experts who are not communicating their knowledge and acting as a point of comparison for self-ratings, which inherently vary according to the individual's personality. Neither this combination nor the colour coded presentation of results have been seen in the literature, though both seem a logical thing to do.

As both the organisations and individual participants are self-selected volunteers, it is important to emphasise that the data cannot conclusively be stated to be truly representative of the organisation categories studied. The lack of any clear trend with either age or job type within the data suggests that these demographic factors are unlikely to be important, but this cannot be stated with certainty. The deliberate choice to focus on SMEs means the work does not capture the composites sector as a whole, this was not the intention.

#### 7.1.1 Value of Knowledge Transfer Studies to participating organisations

The results of the studies are useful for each individual organisation. Network diagrams of who learns from or asks questions of whom show at a glance how robust the organisation's knowledge transfer is- or is not, and combining this with the results of the competence matrix gives a sense check on an otherwise inherently biased piece of self-rating. The two together can be used to investigate working cultures in different groups, identify key people and those who are isolated, and see at a glance where there are gaps in the topics the organisation needs. Opinion based questions show easily what works well, what does not, and which types of knowledge transfer technique would fit with working practices- allowing a manager to make informed decisions.

The majority of participants were not familiar with knowledge network diagrams. Informal comments suggested that the results were considered useful, but these cannot be reported as positive responses per se- there were in some cases expressions of dismay at finding problems of which they were previously unaware. The pilot group is a good example of this, and as the only team that were studied twice during the project the effect of the manager's actions in response to this worrying information can be seen. Two knowledge brokers linked the subgroups within the team- one of whom had just handed in notice to leave the job and the other was a contractor, hence could not be relied upon to remain with the team long term. If these people left the subgroups would be isolated, restricting their learning horizon [179]. This would be detrimental to the individuals- who would not be able to learn from those in other subgroups- the team as a learning unit, and to the results of their work. The manager's concern was entirely reasonable.

In a situation such as this, the manager might assign people from different subgroups to work together, encourage knowledge transfer at team meetings such as through a short talk from a different person each week with questions encouraged, rotate junior team members around experts from all subgroups as part of a mentoring programme or encourage spontaneous communication-casual discussion over a cup of tea (or stronger beverage [168]) can be a very effective form of knowledge transfer. When the pilot group participated for a second time, as part of the wider study, the change was remarkable- the subgroups were now interlinked by multiple routes.

Results from the competence matrix combined with the network diagrams were used to draw conclusions regarding knowledge transfer in two different teams in the Company 6 case study. This demonstrates the value of combining these two techniques. The contrast between the laminators and fitters is notable, with the chatty fitters having effective knowledge transfer and the silent laminators hardly any at all. There is also only one link between the teams, a similar problem to the pilot group. While knowledge transfer between laminators should be encouraged, it would also, in the author's opinion, be worth encouraging links between the laminators and fitters. Hand layup of composite parts can vary a great deal between laminators [4], [26] and the lack of communication suggests they did not discuss the challenges among themselves. As the fitters' work follows on from the laminators', decisions taken by the laminators may affect the options available to the fitters, depending on the part being made. If each laminator delivered the part they laid up, after cure, to the assigned fitter, they have the opportunity to discuss any complications, issues or ideas between them. This both encourages knowledge transfer between the two individuals, expanding their learning horizons, and facilitates organisational learning, as any ideas for improvement could, subject to approval, be tried on the next part. In addition, the more communicative fitters may act as knowledge brokers between the uncommunicative laminators, and in time may encourage direct discussion in the lamination team.

For Company 8, which has a robust, interlinked network, any experts who are transferring knowledge to large numbers of people can be monitored to ensure they are not overwhelmed [31]. Managers should allow time for these experts to carry out their knowledge transfer duties.

Opinion based questions were also of use to participating organisations, illustrating what works well and what does not in the current system, as well as preferences for knowledge transfer options that could be implemented. Informal responses suggest a focus on fixing problems- one manager was extremely worried that over half of their team did not know where to go when they needed help. Had they not participated in the study, this situation would have persisted, with the manager unaware of the problem.

Of course, making use of these results and acting to improve knowledge transfer in an organisation requires support from those at the top. It is worth considering that in truth, an organisation's knowledge rests in the brains of its staff. Some things can- and should- be recorded, but there is no substitute for the tacit knowledge of a skilled and experienced worker. This must be borne in mind when key persons are identified- if they were to leave, would the business cope? Passing their knowledge on to those who will remain is a real concern- and understanding how the workforce seeks out the things they need to know should inform the way this is done.

Good knowledge management saves duplication of work and of mistakes, saving a business time and money. Being able to find what has been done before- including outside one's own team- is valuable. Knowing who to talk to about what is even more so. As a small organisation grows, what was simple can become complicated, so it is worth putting systems in place early on.

#### 7.1.2 Lack of links between Academia and Composites SMEs in this study

The companies which participated in the study were recommended by the academic groups and research institution. It is therefore surprising that the vast majority had no direct links to academic groups or the research institution in their networks, either of those they learn from or those they ask questions of. This is troubling, for while the sample may not be representative of all connections between academia and industry- indeed, by focusing on SMEs, does not cover the direct collaborations between certain large companies and both academic groups and the research institution- it demonstrates a problem in technology transfer. These smaller companies, without large dedicated R&D teams but perhaps more agile than multinational behemoths, could gain significantly by such new technologies but do not seem to benefit from pathways to access them.

Studies of links between academic/research organisations and industry often use proxy measures to identify knowledge transfer links. If a list of collaborations were used to form the inter-organisational knowledge networks, rather than directly asking those working there to identify persons they learn from, the proxy network would show links between the companies and the academic groups which recommended them. This suggests that such proxies may not deliver a realistic picture of knowledge transfer between organisations at the employee level.

The method used here, where knowledge workers are asked to identify those they learn from, is used in studies of large organisations with multiple sites or working groups. Having only 3-4 links between sites was considered a problem for knowledge transfer [191]- a complete lack of knowledge transfer connections is therefore a matter for concern where, given the remit of the academic groups and research institution, those connections should be there.



A study using this method to identify links between companies- mostly small companies- and research and training institutions in a different industry, wine production, showed that where local government encourages such institutions, a large number of wineries exist and the research institutions act as hubs for knowledge transfer, with “product upgrading” being facilitated by institutions which link different communities of wine producers, giving a variety of “knowledge resources” [206]. The UK research institution in composites manufacturing is intended to work with manufacturers across different sectors in technology development, provide training and facilitate knowledge transfer- including to SMEs. The current status compares poorly to these wine production research institutions, though it should be noted that a new initiative for SME engagement has recently been established.

The research institution is well connected with the UK academic group, so improving links to SMEs should help to facilitate technology transfer from academia to industry. If this new initiative is to be successful- and any similar initiative which the Canadian academic group may carry out- it would be sensible to attempt knowledge transfer in the manners preferred by industrialists, as identified by this study. Interpersonal knowledge transfer is clearly popular and there is demand for training courses.

Taught by staff from the research institution or academia, such courses would not only deliver teaching but form a link between the students and teacher- they could continue to communicate after the course is completed. Group exercises could also help links to form between students. Active learning is higher viscosity than passively listening to lectures [31] so practical exercises should be encouraged. Group discussions while gathered around a piece of equipment, talking about how it works, would also be useful both for networking and encouraging ideas to form for how the technology might be used in each company. If possible, courses should be scheduled to make it easy for SMEs to allow staff to attend- losing a person for a week is a much bigger issue in a company of 20 than a company of 2000- so short courses, perhaps scheduled to fit factory shutdowns for maintenance or similar, would be particularly useful.

Assigning specific employees as contact points for SMEs may be beneficial, as this allows a relationship to form and encourages asking of questions. They should ideally be experts in technologies the SME uses or is interested in developing. As the research institution has poor know-who compared to other organisation types, a directory of experts would be useful internally and externally.

As courses are not always practical, or as supplemental material, useful information could also be made available online. Web search is a popular choice for answering questions and the results do show interest in an internet based knowledge repository. This should not take the form of academic papers as- perhaps unsurprisingly- these are not popular in industry. Material made available for knowledge transfer should be designed around the needs of industry and updated regularly. The Knowledge Transfer Resource discussed further on is a suggested format for this.

The Knowledge Transfer Studies have been useful to the participating organisations and, when the whole dataset is analysed together, illustrate the current state of knowledge transfer between the organisations. This could be used to monitor the effects of any initiatives intended to change the current picture, and keep track of opinions on what does and does not work. As collating the information across many companies is useful, and SMEs may not have the resources to carry out these studies themselves, it is recommended that the research institution should offer this as a service, to be carried out regularly, perhaps once per year. Data can be provided to each participating organisation, and- alongside an internal study of its own staff- the research institution can collate the data to monitor the -hopefully- success of its SME engagement initiatives.

### 7.1.3 Knowledge Transfer in Academia and Industry

In all types of organisations studied, interpersonal knowledge transfer is considered highly desirable- the majority wish to talk to other people, be it through a taught course, mentoring, or a chat over a cup of tea. Academics were however much less likely than their research institution or industrial fellows to talk to colleagues other than their supervisor and found team meetings and on the job learning less useful. This suggests that teamwork may be less popular in academia than in industry, but the popularity of going to the supervisor with questions is not notably different between academia and industry. Employees at SMEs are more likely to talk to supervisors than at larger companies or the research institution. Taught courses were considered more useful by academics and research institution staff than industrialists, but demand for training courses is above 70% and very close in value for all organisation types.

Web search is also popular and there is demand for an internet based knowledge repository, though this is less popular than training courses and on a par with other options such as a central store of manuals. It is interesting that more people rated a central store of manuals highly than said they currently go to manuals or manufacturer's guides. It is possible that storing all the manuals in one place would make a significant difference- but also possible that there is a difference between enthusiasm for doing something in the future and the reality of what people actually do.

Similarly, formal training courses are considered the most useful suggested option for knowledge transfer- but far fewer people, especially in industry, consider current taught courses useful.

The questionnaire found no correlation between job type or age and answers to the opinion based questions. Those with computer based jobs are not able to contribute to a discussion forum or wiki more often than those with hands-on or meeting based jobs, and enthusiasm for web search as a way to answer questions is broadly consistent across these groups.

It is notable that while it is common to begin a project with a search for relevant knowledge, literature surveys are hardly ever carried out in industry. It is perhaps unsurprising that academic papers and conferences are not popular sources of knowledge in industry, as both involve jargon and are often expensive, but a clear demonstration of this is nevertheless worth having. It may be more surprising that conferences and seminars are not thought of as places to go with questions in academia either, but these are valuable as networking opportunities and a chance to publicise one's own research as well as finding out more about the work done by others.

Recording lessons learned is commonly considered an important part of knowledge management, yet the data suggests it is often not carried out. When it is, these lessons are only of use if they exist in a form which is easily accessible and invites those beginning a new project to find them and learn from them. A large document of lessons learned from procurement of the bespoke autoclave required for developing cure monitoring technology has been produced, but is unlikely to have been read by those planning other large equipment purchases as at the time it was written no system was in place to facilitate this.

The demand for interpersonal knowledge transfer drove the trial of a taught course in dielectric monitoring in composites manufacture, conducted with EngD students and staff at NCC. Taught courses, however, can only be provided in person to a limited number of people, usually requiring geographical coincidence. As web search was also popular as a method of searching for knowledge- far more than other non-interpersonal options- and an internet based knowledge repository was considered potentially useful by over half of respondents, it is hoped that an internet based option might be a useful second choice.

In an attempt to provide the missing interpersonal element for such a repository, without resorting to discussion forums (not considered useful), short explanatory videos were made by the present author for the two technological aspects of this work: In-Process XCT Scanning and Cure Optimisation and Control with Dielectric Monitoring. The videos are aimed at a non-academic audience with some knowledge of composites manufacturing, with much of the content delivered by a person speaking to the camera, intended to give a 'human face' to the experience.

## 7.2 In-Process micro-XCT Scanning for Defect Tracking

Minimising waste, both of time and of material, is an important factor in a businesses' efficiency. Understanding the behaviour of the resin and fibres during manufacture is important here. Defects in manufacture are impossible to avoid [4], and can result in an expensive part, which has taken a lot of time, energy and effort to make, being scrapped. Where active process control with dielectric cure monitoring may, in future, allow us to automatically modify the cure on the fly in order to achieve the required properties and minimise some types of defects, achieving this will require a thorough understanding of how both resins behave and defects change and develop during the cure process.

In-Process micro-XCT Scanning allows us, for the first time, to track the evolution of a defect (or feature) throughout the cure. This is demonstrated in Chapter 4.

### 7.2.1 Demonstration of In-Process micro-XCT during composite cure

As this is intended to be useful in industry, it was important to use an industrial CT-scanner rather than a synchrotron. While the synchrotron would undoubtedly deliver better results, they are expensive to use and there are few available, meaning this is not practical for regular use as part of product development in industry. Tracking the evolution of defects or features on sections of part geometry during cure may inform design decisions or process decisions, such as response to different cure cycles.

The value of uninterrupted, in-situ micro-XCT scans is demonstrated by comparison to ex-situ studies involving multiple quenched samples [27], [28]. The work presented in Chapter 4 detected a feature of void evolution which was not seen in the quenched sample studies. This is to be expected, as the multiple samples used are not likely to be identical, and the number of scans is relatively small, so changes can easily be missed. Tracking the same sample with repeated fast scans during cure ensures these small but potentially significant changes are detected.

Development of the method was not without difficulty, both in terms of practical equipment and evaluation of the 3D volumes. There is an inescapable trade-off between image quality and speed. As capturing fast scans- minutes rather than the usual hours- of a sample which is changing requires speed, image quality was far lower than that achieved in a standard scan, though sufficient for our purposes.

The material chosen- largely due to availability- for the heated tool, ceramic, caused significant noise due to X-ray scatter- in the author's opinion a less dense material should be used in future.

The large volumes of data (20TB) are best analysed in an automated manner. This was achieved for a carbon fibre reinforcement, but proved beyond the software where glass fibre was used, as the routine in the commercial software which automatically detects boundaries between materials of different densities located the glass-resin boundary rather than the resin-air boundary which marks the edge of a void. Matters such as this could be solved by different image analysis routines.

Issues like sample placement and arranging of wires and hoses in a manner which allows the stage to rotate were perhaps the most difficult to solve, and with more time and budget could be dealt with in a neater manner. The somewhat ad-hoc setup proved more than sufficient to not only demonstrate the principle of In-Process XCT Scanning of composite parts but also to obtain useful results regarding both defect evolution and resin behaviour.

### 7.2.2 Evolution of studied defects during cure

The results of the investigation into the evolution of ply drops and tow gaps during cure provide an example of the sort of knowledge which can be obtained with this powerful new experimental technique.

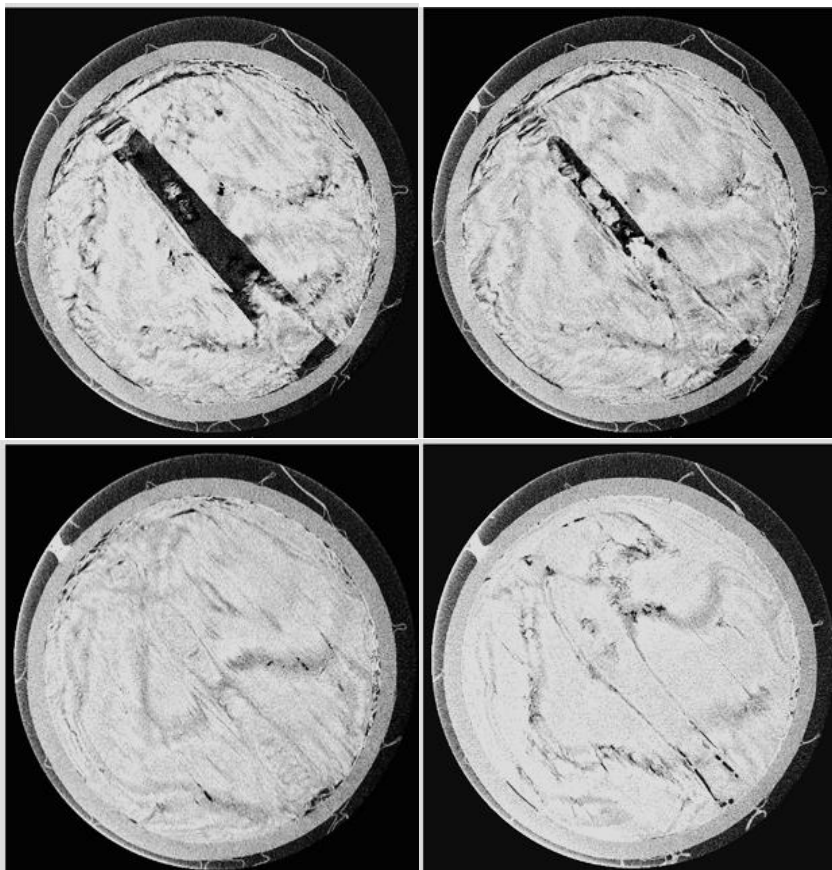

Figure 7.1: Horizontal slices through the centre of CT reconstructions of a tow gap during cure. Top left: original defect. Top right: 1 hour, 39°C, resin flowing into defect. Bottom left: 2 hours, 66°C, gap appears full. Bottom right, end of cure, voids now visible in position of original defect. Chapter 4.

It was found that the total void volume present in the defect region of the small test part, having reached a minimum, increases prior to gelation. Comparison with the model for the resin cure [43] showed that this increase occurs around the time of minimum resin viscosity. This is in line with the theoretical prediction of de Parscau du Plessix et al [160], which predicts an increase in the radius of small voids as resin viscosity decreases and temperature increases.

Comparison of tow gaps, in line with the fibre direction, and ply drops cut across the fibre direction showed clear differences, with the ply drop voids remaining larger throughout. This is expected, as where the gap is in line with the fibre direction the fibres can move laterally into the space, whereas with a cut across the fibre direction only the resin can flow into the gap.

Defects such as these are often unavoidable [4] when using automated fibre placement, but are undesirable in a part due to effects on strength and fatigue behaviour [153], [155], [156]. The position of the defect can be important [48], [154], so tracking through the cure to assess changes in defect geometry may be important in design decisions.

### 7.3 Dielectric Cure Monitoring for Process Optimisation

Using dielectric monitoring for process optimisation and control has the potential to deliver increased efficiency in composites manufacture. As simulation may not always reflect reality, having sensors in contact with the part, tracking the cure, valuable for both cure optimisation and quality assurance. One might reasonably equip a prototype with many sensors to build up an understanding of what is happening throughout the part, perhaps including modifying a model to reflect the real results. In a production part, numerous embedded sensors would likely be unwanted as they would affect the structural properties- but with reference to a full dataset from prototyping, a surface contact sensor or one embedded in a tag which will later be cut off would likely be sufficient for both tracking and controlling the cure. Chapter 5 reports the test of a dielectric analysis system, in an industrial environment, for cure monitoring and active process control and comparison to both laboratory tests and simulation.

#### 7.3.1 Active Process Control and Quality Assurance

Active process control has the potential to allow the cure to be modified based on the real state of the resin in that particular part (or batch) at that particular moment, managing the unavoidable variety in material batches, environmental conditions, human factors and machine behaviour which can lead to varied results in what should be a reliable process. Here this is used to end the cure when a specified material property has been obtained, minimising energy usage.

Other researchers have used the same principle in a very different manner, controlling liquid resin flow into a mould in order to eliminate dry spots by opening or closing vents based on resin arrival detection [24].

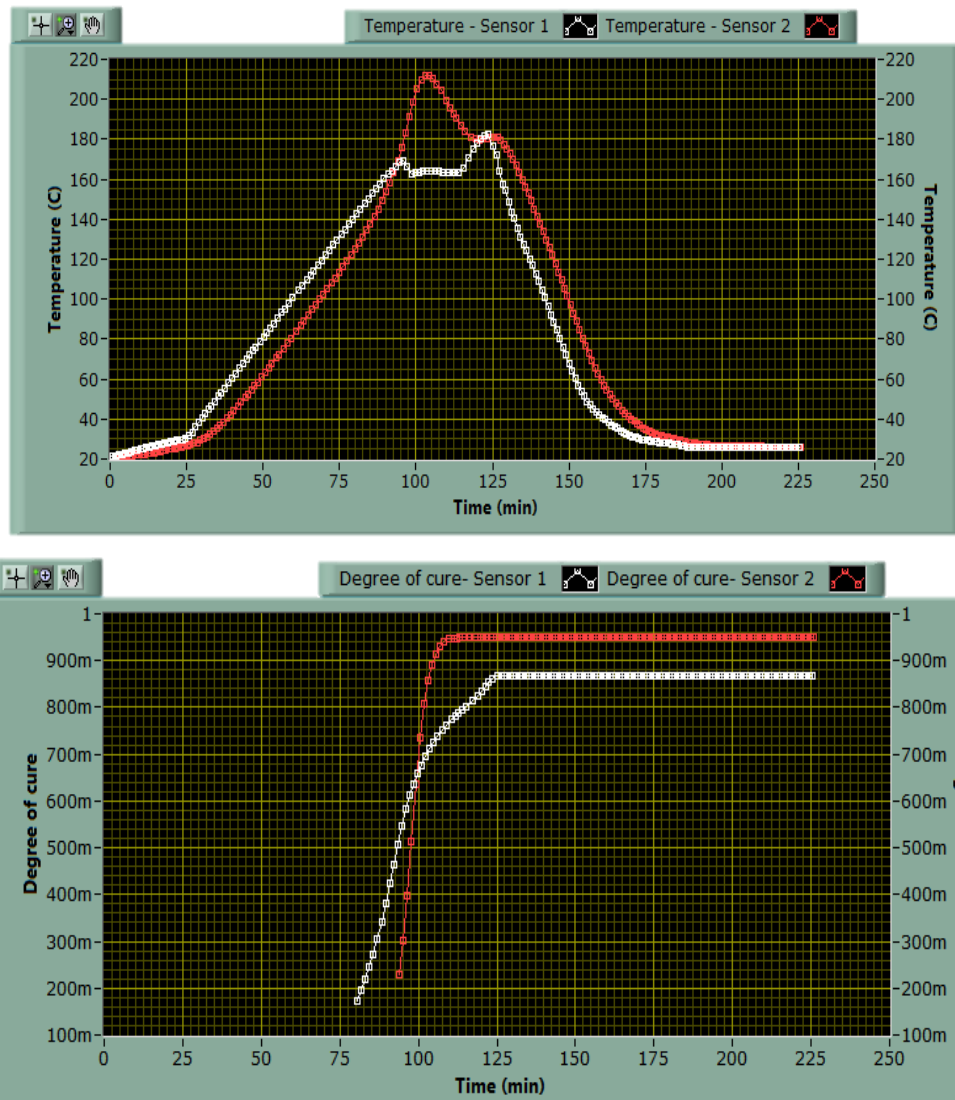

Figure 7.2: Active process control. When both sensors reach 85% degree of cure (lower graph) the autoclave automatically cools down and ends the cure (upper graph). Sensor controlled single hold cure, Chapter 5.

The example part used here, a stepped wedge, was chosen to represent the extreme range of part thicknesses, allowing the cure at each extreme to be tracked and hence making sure the cycle reached the requirements for both. This also provided the opportunity to study this otherwise well characterised, popular resin system when subjected to a non-standard cure.

It was found that where 85% degree of cure is sufficient, significant energy savings could be made. A shorter cure at the temperature recommended by the manufacturer was found to deliver greater energy savings than a full length cure at a lower temperature.

However, the lower degree of cure also meant a significantly lower glass transition temperature in the final part, varying with the thickness of the step. If the part is not intended to be used at high temperatures this is not an issue, but where a high glass transition temperature is required, less energy savings can be made.

In general, if dielectric monitoring is to be used to optimise a cure cycle, the resulting cycle- and hence the potential savings- depend very much on both the choice of resin and the requirements for the part(s) under manufacture.

Quality assurance, important in all manufacturing, is particularly vital where the parts are critical to human safety. In industries such as aerospace- a leading use of composite parts- it is especially valuable to have a traceable history of each part, with measurements of the key metrics wherever possible, to ensure each individual part meets the stringent requirements. Dielectric monitoring can be used to check the material properties prior to cure [25] to ensure they meet requirements and monitor variation between batches, and to track properties throughout the cure, providing evidence of the specific development of each individual part, including the final properties.

For quality control, it is necessary to act based on the readings obtained from the sensors. This may be as simple as disposing of parts which do not meet the necessary standards- a good safety measure- but, in order to decrease waste, it is preferable to make changes during the cure in order to bring the part up to the specified standard. In this study active process control was used only to end the cure when the required degree of cure had been obtained, but this is only a first step. It would be possible to change the temperature and pressure of the autoclave- or another manufacturing method- in response to sensor readings in real time.

### 7.3.2 Comparison of dielectric analysis results to laboratory tests

The final, end of cure measurements of degree of cure and  $T_g$  were compared to commonly used laboratory tests- DSC and DMA respectively- as a check on the results.

The dielectric analysis system measures degree of cure using a method (derivative of the logarithm of the imaginary impedance maximum) which has been demonstrated to deliver comparable results to DSC [105]. This demonstration used a different resin system to the Hexcel 8552 used here. The manufacturer of the dielectric analysis system provided a model for calculating the degree of cure of 8552 using this method, but the details are proprietary. Verification against an independent measurement was therefore necessary. In all but one instance, the dielectric analysis measurement of final degree of cure was within experimental error of the DSC measurement carried out using a sample from close to the sensor position.



The one discrepancy is 1% degree of cure between the error bars of the two measurements. As all other measurements were within the error and this is a small discrepancy, it seems reasonable to consider the dielectric analysis measurements reliable for this resin. Degree of cure will not be exactly the same throughout each step of the wedge, so a discrepancy this small could simply be due to variation between the sensor and DSC sample locations.

The dielectric analysis system uses the DiBenedetto equation from the NCAMP model for 8552 [23] to convert degree of cure to  $T_g$ . This does not include the drop in  $T_g$  due to degradation at very high degree of cure. In one case the dielectric analysis result did not match the DMA result for this reason. There is only one other discrepancy, again very small: 1 degree Celsius between the limits of the two error bars. As above, it seems reasonable to consider the dielectric analysis measurements reliable as this small discrepancy could be due to variation within the material.

The technology has been demonstrated in an industrial environment, and is in use in a small number of manufacturing facilities- most notably for quality control in a pultrusion line [34], [227]- but further development is needed before it is ready for use in an autoclave at an industrial level, largely in ruggedization of the flexible sensor connectors. These connectors break easily and are not possible to use while wearing heavy protective gloves. This problem is certainly something which can be solved.

The manufacturer of the dielectric analysis system may wish to work with manufacturers of autoclaves and other composites manufacturing equipment to develop equipment with a built in sensor system, rather than added using pass-throughs at a later date. This would be a unique selling point for the autoclave and a way for the dielectric monitoring system to reach a large market- companies may not wish to modify an autoclave to trial a new system, but if it is built in and verified by the autoclave manufacturer there is less of a barrier to the purchase.

### 7.3.3 Discrepancy between simulation and other measures

Two types of simulation were trialled. Simulation using an ideal cure cycle and heat transfer model ('Sim') was found to be significantly different to reality. This is due to the difference between the ideal cure cycle and the reality. As the thicker extreme of the part begins to exotherm, the autoclave drops the air temperature to control this, as a safety measure. This results in the thinner extreme dropping in temperature. The hold is only counted as 'started' once the thin extreme comes within 5 degrees Celsius of the set temperature, so the actual hold time is rather longer. In addition, the autoclave behaviour can vary, for example a slight maintenance issue on a valve may lead to significant pressure and temperature fluctuations during the cure.

For the above reason, simulation based on an ideal cure cycle should be considered a starting point for study of a cure only, as it is likely to be significantly different to the cure which occurs in reality. The results of this type of simulation ('Sim') were not taken forward for comparison to the dielectric analysis results.

The second type of simulation ('Sim\_data') is expected to be far closer to reality. Temperature data from thermocouples embedded in the centre of each step during each experimental run were used with the NCAMP 8552 cure kinetics model [23], [44] to generate theoretical degree of cure and  $T_g$  data throughout each cure cycle. The relationship between degree of cure and  $T_g$  is the same as that used in the dielectric analysis system, but the calculation of degree of cure comes from the cure kinetics model.

This was found to significantly under-predict both degree of cure and  $T_g$  compared to both the dielectric analysis and laboratory test results. Throughout a cure cycle, the dielectric analysis reading is always a higher value than the simulation output.

The degree of cure- $T_g$  relationship follows the expected trendline, meaning the discrepancy is in the cure kinetics model, or the simulation software's implementation of this. As the NCAMP model is based on experimental work carried out approximately a decade ago, this may indicate a change has been made to the resin formulation- or that there is significant variation between batches. It would be worthwhile to repeat the experimental work carried out for the NCAMP model using resin from a number of different, modern batches, to ascertain whether or not the model needs to be updated.

#### 7.4 Knowledge transfer resource for dielectric cure monitoring

Improving knowledge transfer both between academia and SMEs and within individual organisations can help to solve problems in manufacturing and perhaps lessen the time taken for promising new technologies to reach their potential, bringing benefit to industry and the wider world.

The Knowledge Transfer Studies suggested that interpersonal knowledge transfer- likely through taught courses- is the best way to achieve this. However taught courses are not always an option, requiring people to take time away from work and geographical coincidence with the teacher. Even where such courses are available, assimilating a large amount of knowledge in a short amount of time is difficult. Reference material is therefore needed. Unlike academic papers, which are not popular in industry, this should be designed to be useful for industrialists and in an easy to digest format. Web search was also a very popular option when looking for answers to questions, so such a resource should be suitable for using online.

A framework for knowledge transfer between academia and industry is being developed by the University of British Columbia, being a framework for 'Knowledge in Practice Documents' [115]. These are intended to provide useful information and industrial examples surrounding technologies used in composites manufacture, and troubleshooting of problems, written by academics and intended to be kept updated. A pdf based document of this nature, on the topic of dielectric monitoring, was contributed to the system by the author.

Drawing on all of this plus personal experience of working at the National Composites Centre during the EngD, an example of a knowledge transfer resource for composites manufacture has been constructed. Suitable for use on the web, but with a human talking through the basics in an introductory video and a simple clickable interface, this is a suggestion for improving knowledge transfer- and hence technology transfer- between academia and industry.

Dielectric monitoring is a near perfect topic for this. Having been used in academia for decades [19], [20], [97], [215] but barely heard of in industry, delivering on its potential requires a combination of technical development and transfer of knowledge from academia to industry. Previous work by Partridge and Smart [227] (EPSRC grant EP/F012489/1) resulted in a DVD (video file copyright Cranfield University, included in the Knowledge Transfer Resource) intended to address this, but industrial use of the technology remained low. The new knowledge transfer resource, while including video files, is more interactive and intended to be updated as the technology progresses.

The Knowledge Transfer Resource is structured around a simplified, clearly laid out version of the framework proposed by Fabris and Poursartip [115], and much of the content from the Knowledge in Practice Document for dielectric monitoring, written by the author of this thesis, is included in the Knowledge Transfer Resource. However, as a linked PowerPoint dominated by images and bullet points it is hoped that this will be less intimidating than a long text document. An industrialist may click through only the items and case studies that are relevant to their company, with links to the background science provided where necessary, and links to external documents- including manufacturer's guides and academic papers- for those who want more information.

Resources such as these should be regularly updated to keep up with developments in the field, which requires an institution willing to be responsible for both producing and maintaining them. As an institution with a remit to deliver technology transfer from academia to industry, the National Composites Centre would be a good fit for this- but academic groups could also be an option.

This resource has been trialled with EngD students, but, if it is considered potentially useful, could now be shared with industry, revised and- no doubt- improved.

## 7.5 Future work

Having been achieved for the first time as part of this project, In-Process XCT Scanning is at a far earlier stage of development than dielectric cure monitoring. While CT scanners are sometimes used for non-destructive testing of appropriately sized parts, scanning sections of test items during development and investigation of damaged (deliberately or otherwise) parts, they are not built into any composites manufacturing process at present. For small items and test parts built to investigate new designs, materials and techniques it would be feasible to follow the method developed here, though there is scope for improving the equipment from its initial ad-hoc setup.

In the near term, use of In-Process XCT Scanning in research, to improve our understanding of defect and feature evolution through the cure process, opens up a wide range of possibilities. The technique can in principle be used to investigate the behaviour during cure and evolution of any feature at an appropriate length scale. This might for example include consolidation in corners or distortion of through thickness reinforcements.

The initial work on the tow gap and ply drop, may be used to inform design decisions.

Understanding the likely evolution of the feature may help to decide the optimum location for unavoidable defects. If expanded to study a variety of gap sizes and geometries, this has the potential to provide useful input to decisions on manufacturing tolerances- likely reducing waste by allowing us to identify which of the early stage defects mean a part will not meet the requirements, and which are likely to become acceptable during the cure process. Similar work could be done for other defects and resin systems.

Results from the initial work presented here have been discussed with colleagues at the University of Bristol as a possible comparison for their theoretical modelling of fibre movement during cure [151]. A direct, real comparison between a model and reality offers the possibility of improved accuracy in future models, or validation of the existing model.

It would be particularly valuable to develop improved image analysis routines, to analyse each sequence of scans automatically. An ability to do this for glass fibre as well as carbon fibre reinforcement would be particularly useful. For a fast scan as carried out in Chapter 4, identifying the difference between carbon fibres and mostly-carbon resin in the reconstruction is very difficult. Use of glass fibres would allow the study of features such as fibre waviness. It is theoretically possible to use image processing to estimate stresses on the part as it cures- this would be an interesting and potentially useful addition.

The resolution achievable by an XCT scan is limited by the spot size of the X-ray beam, the detector resolution and by the geometric magnification achievable in the scanner cabinet. For any given scanner, a larger sample means a lower magnification as the sample must be physically as close to the X-ray source as possible. Other limitations of XCT Scanning include the flux of X-rays available. Advances in XCT Scanning technology to address these issues could lead to higher resolution in-process scans on larger objects. Synchrotrons can also be used, though these specialised facilities have limited availability and cannot easily be added to a factory for regular use. Laser Wakefield Accelerators offer particular promise here- though not yet commercialised- as using the laser for X-ray generation allows a high flux of collimated X-rays, with a very small spot, to be produced [138]. Additionally, the X-rays are in phase, meaning phase contrast imaging can be used to produce more detailed scans, making it easier to see the difference between two mostly-carbon materials. Initial tests of this technology on composite parts (not in-process) have proved promising.

It may, with future technology, become possible to integrate XCT Scanning into manufacturing equipment, allowing in-process scans of larger items during standard manufacturing processes. If feasible at all this is a very long way off, with many challenges, including how to integrate X-ray generation and detection with the inhospitable high pressure and high temperature environments characteristic of composites manufacture.

In the slightly less long term, current use of CT scanners by some composites manufacturers- at least in some cases through use of the facilities at NCC- offers hope that adoption of this technique as part of product development in industry, if it proves useful, may take less time than dielectric cure monitoring, which requires new technology to be integrated with the manufacturing process.

Having created a knowledge transfer resource aimed at industry for dielectric cure monitoring, the obvious next stage of this work is to trial this with industrial users- both those few who already use the technology, and others where a potential for strong contribution to their business has been identified but they have no experience in this area. Feedback on this will not only help improve the knowledge transfer resource- which can then be used as a template for other technologies- but also be useful in improving awareness of dielectric cure monitoring in industry.

Dielectric monitoring certainly has the potential to be very useful. In addition to the knowledge transfer and awareness aspects, the system tested requires ruggedisation before it can be considered truly industry ready. The flexible sensors and particularly the connectors they must be attached to inside the autoclave are delicate, fiddly and unlikely to last long under continuous use in a factory.

This presents a problem for the manufacturer- while a more rugged system is definitely possible, investing in this without knowing whether the technology will be taken up at large scale by composites manufacturers represents a risk. However, representatives of companies which are members of NCC are unlikely to report the current system as factory ready. The manufacturer would be well served in finding a partner to develop this further and continue the work on integration and feedback to manufacturing equipment such as autoclaves. Equipment manufacturers would be an obvious choice. The author and others at NCC and the University of Bristol have worked with the manufacturers of both the dielectric monitoring equipment and the bespoke autoclave on an informal basis in order to achieve the initial process control demonstrated here. A specialist in liquid resin injection equipment has also expressed an interest as a result of this work, though any future contact must be direct between the two companies. The interest was specifically in using the sensors to monitor the levels of resin and hardener as they mix and develop active control of the mixing based on this.

Active control of the cure, demonstrated here on a basic level, has a lot of potential. It would be possible to make far more subtle and detailed adjustments to the cure process than simply cooling down the autoclave when a desired degree of cure is reached. Improved connections for the cure monitoring system using direct current, and possibly the addition of other systems such as Fibre-Bragg gratings to measure strain would also be useful, both in terms of understanding and optimising the cure process and perhaps providing another dataset which might be used for control.

The results of the work done to date may be of use in refining theoretical models, both for the material cure and for energy use and cost modelling. Perhaps more importantly, the discrepancy between simulation and results of laboratory tests and dielectric analysis suggests that the model used for 8552 should be revisited. This is not intended to suggest that it is intrinsically wrong- rather than the resin formulation may have changed, in which case the cure kinetics model may need updating. This provides an example of the value of living documents, which are continually updated as needed- perhaps in future a resource of resin models might allow anyone who finds a discrepancy to note that a model needs to be checked.

Along with the lessons learned from the procurement of the autoclave, this demonstrates the value of knowledge transfer within a business as well as more widely between academia and industry. The results of the knowledge transfer studies have been extremely well received, and companies might benefit from performing these regularly and tracking changes over time, e.g. for monitoring the effect of any new policies.

To carry these out in future, it would be worth investing some effort in digitising the survey. Whilst an emailed link to an intranet survey does not result in an adequate response, where businesses make this a requirement rather than asking for volunteers as was the case here, it could be built into a normal staff review process. Digitising the survey would save significant time in data entry and much of the processing could be automated, though interpretation of the results would still require a human touch.

It would be worthwhile for organisations invested in developing links between academia and industry to also carry these out with their target companies in order to monitor their progress and further tailor their knowledge transfer to the requirements of industry. As new knowledge transfer techniques- including for example the use of Augmented Reality- are developed these certainly should be included.

Finally, it is worth considering including knowledge transfer as a key aspect of all future technology development work. The results are only useful if the message gets out to those who would benefit from it.

# Chapter 8

## 8 Conclusions

1) Knowledge Transfer Studies were conducted by questionnaire with industrial and academic organisations in the advanced composites space in two countries, and were demonstrated to be useful to the participating organisations. The network diagrams of knowledge transfer within an organisation or group were new to most participants. The utility of knowledge network diagrams in particular is demonstrated in the changes made to the pilot study team. The novel presentation of combined data from knowledge networks with a competence matrix is shown to be of value to a business through the Company 6 case study.

2) The majority of companies participating in this study do not have any direct knowledge transfer links with the academic groups and research institution, despite being recommended by these groups. The main exception to this is a spin-off company from the Canadian academic group. Two others have very weak links via a single person in only one of the two network types. The research institution and UK academic group are thoroughly interlinked, but at the time of the study the research institution does not appear to be facilitating knowledge transfer between the academic group and the participating companies.

3) The questionnaire results indicate a strong desire for interpersonal learning through talking to others; especially in industry. Academics are less likely to discuss work with colleagues who are not their supervisor and fewer find team meetings useful. There is notable demand for training courses. Web search is also very popular. In industry, academic papers are rarely read and few participants carry out literature surveys. Conferences and seminars are not often among the top choices as sources of knowledge in either industry or academia. These factors together may be a barrier to technology transfer to such SMEs, and could contribute to the lack of awareness of technologies well known in academia such as dielectric cure monitoring.

4) In-Process XCT Scanning of composite samples during manufacture has been demonstrated for the first time, allowing defects and features to be tracked through the cure process, including an aspect of void evolution which was not seen in studies using multiple quenched samples [27], [28]. The method does not require large scale scientific facilities, thus could in principle be used during the design and prototyping process for a new composite part. Regions where defects are unavoidable, or difficulties are foreseen with the geometry, could be cured in an industrial CT scanner and the evolution of the defects and features tracked.



5) This proof of principle has yielded a useful discovery, showing how voids due to tow gaps and ply drops, defects characteristic of Automated Fibre Placement, evolve in a material used in aerospace structures. The total void volume increases slightly at minimum resin viscosity, and these voids are fixed shortly thereafter at gelation. This fits with the theoretical prediction of de Parscau du Plessix et al [160]. Tow gaps, where the defect is along the fibre direction, have smaller total void volumes throughout than ply drops, as expected

6) Cure monitoring sensors have been used for active process control with an autoclave, allowing us to automatically turn off the autoclave when the chemical reactions that make up the cure have progressed sufficiently for the part under manufacture while using the measurements from the sensors as quality assurance. For a very commonly used material, where the part will not be used at very high temperatures, the energy and CO<sub>2</sub> saved for each batch can be the equivalent of that required to drive a standard petrol car 100 miles [14].

7) The dielectric analysis system tested delivered end of cure measurements of  $T_g$  and degree of cure that were largely comparable to those obtained by DMA and DSC respectively, with the majority being within experimental error. The system has some practical concerns that should be addressed for regular use in industry, but these are far from insurmountable.

8) The simulation software tested, using thermocouple data from the sensor location in the experimental runs, reported lower values of  $T_g$  and degree of cure than the dielectric analysis system throughout the cure, and end of cure values for both were lower than those obtained by DSC and DMA. The simulation and dielectric analysis systems use the same degree of cure- $T_g$  relationship, but the simulation software calculates degree of cure based on a cure kinetics model [23], [44]. The cure kinetics model is based on experimental work from approximately a decade ago, so it is possible the resin system may have changed in the intervening period.

9) An industrially focused Knowledge Transfer Resource for dielectric cure monitoring was created, with reference to the results of the Knowledge Transfer Studies. This is intended to facilitate technology transfer from academia to industry, by illustrating uses of the technology and providing useful information relevant to industrial decision making. The format could be applied to other technologies.



## References

- [1] Cambridge English Dictionary, “composite Meaning in the Cambridge English Dictionary.” [Online]. Available: <https://dictionary.cambridge.org/dictionary/english/composite>. [Accessed: 20-Sep-2018].
- [2] Composites Leadership Forum, “The 2016 UK Composites Strategy,” 2016.
- [3] Composites World, “BMW formally launches i3 manufacture and assembly : CompositesWorld,” *Composites World*, 2013.
- [4] K. Potter, “‘But How Can We Make Something Useful Out of Black String?’ The Development of Carbon Fibre Composites Manufacturing (1965–2015),” in *The Structural Integrity of Carbon Fiber Composites*, Cham: Springer International Publishing, 2017, pp. 29–57.
- [5] National Composites Centre, “National Composites Centre.” [Online]. Available: <https://nccuk.com/>. [Accessed: 23-Sep-2018].
- [6] M. Elkington, C. Ward, and K. Potter, “Automated layup of sheet prepregs on complex moulds. .,” in *SAMPE Long Beach Conference*, 2016.
- [7] D. H.-J. A. Lukaszewicz, C. Ward, and K. D. Potter, “The engineering aspects of automated prepreg layup: History, present and future,” *Compos. Part B Eng.*, vol. 43, no. 3, pp. 997–1009, Apr. 2012.
- [8] National Composites Centre, “Equipment | National Composites Centre.” [Online]. Available: <https://nccuk.com/equipment>. [Accessed: 23-Sep-2018].
- [9] G. Chapline *et al.*, “Materials and Manufacturing,” *Engineering Innovations*, pp. 200–225, 2006.
- [10] T. K. Henriksen, “Trends in Materials Requirements in Spacecraft Structures and Mechanisms Torben K . Henriksen Head Structures Section,” in *Antenna*, 2008, pp. 1–26.
- [11] L. Haines, “PARIS soars to Guinness World Record • The Register,” *The Register*, 2012. [Online]. Available: [https://www.theregister.co.uk/2012/02/17/paris\\_guinness/](https://www.theregister.co.uk/2012/02/17/paris_guinness/). [Accessed: 23-Sep-2018].
- [12] L. Haines, “PARIS skins up with Rizlas and dope • The Register,” *The Register*, 2010. [Online]. Available: [https://www.theregister.co.uk/2010/07/23/paris\\_skin/?page=1](https://www.theregister.co.uk/2010/07/23/paris_skin/?page=1). [Accessed: 23-Sep-2018].

- [13] Hexcel, "HexPly® 8552 Epoxy matrix (180°C/356°F curing matrix)." 2016.
- [14] The Carbon Trust, "Conversion factors," 2016.
- [15] Hexcel, "HexPly® M21 180°C (350°F) curing epoxy matrix." 2015.
- [16] G. M. Maistros and I. K. Partridge, "Dielectric monitoring of cure in a commercial carbon-fibre composite," *Compos. Sci. Technol.*, vol. 53, no. 4, pp. 355–359, Jan. 1995.
- [17] I. K. Partridge and G. M. Maistros, "Dielectric Cure Monitoring for Process Control," *Compr. Compos. Mater.*, pp. 413–426, 2000.
- [18] G. M. Maistros, H. Block, C. B. Bucknall, and I. K. Partridge, "Dielectric monitoring of phase separation during cure of blends of epoxy resin with carboxyl-terminated poly(butadiene-co-acrylonitrile)," *Polymer (Guildf.)*, vol. 33, no. 21, pp. 4470–4478, Jan. 1992.
- [19] N. Sheppard, S. Garverick, D. Day, and S. Senturia, "Microdielectrometry: A New Method For In Situ Cure Monitoring," in *26th National SAMPE Symposium*, 1980.
- [20] F. A. Martin *et al.*, "Dielectric Cure Monitoring of a Fast Curing Resin," *20th Int. Conf. Compos. Mater.*, no. July, pp. 19–24, 2015.
- [21] D. Mulligan, S. Gnaniyah, and G. Sims, "Measurement Good Practice Guide No. 62 Thermal Analysis Techniques for Composites and Adhesives Second Edition," 2003.
- [22] G. Maistros, Q. P. V Fontana, D. Attwood, and J. S. Hudd, "Use of modulated differential scanning calorimetry to observe vitrification during epoxy resin cure," *J. Mater. Sci. Lett.*, vol. 16, no. 4, pp. 273–275, 1997.
- [23] A. Shahkarami, D. Van Ee, and A. Poursartip, "Material Characterization for Processing: Hexcel 8552 Material Model Development Final Project Wrap-Up," 2009.
- [24] M. Devillard, K.-T. Hsiao, and S. G. Advani, "Flow sensing and control strategies to address race-tracking disturbances in resin transfer molding - Part II: Automation and validation," *Compos. Part A Appl. Sci. Manuf.*, vol. 36, no. 11, pp. 1581–1589, Nov. 2005.
- [25] D. Kim, T. Centea, and S. R. R. Nutt, "In-situ cure monitoring of an out-of-autoclave prepreg: Effects of out-time on viscosity, gelation and vitrification," *Compos. Sci. Technol.*, vol. 102, pp. 132–138, Oct. 2014.
- [26] K. D. Potter, "UNDERSTANDING THE ORIGINS OF DEFECTS AND VARIABILITY IN COMPOSITES MANUFACTURE," in *Proceedings of the 17th International Conference on Composite Materials*, 2009.

- [27] T. Centea and P. Hubert, "Measuring the impregnation of an out-of-autoclave prepreg by micro-CT," *Compos. Sci. Technol.*, vol. 71, no. 5, pp. 593–599, 2011.
- [28] L. Serrano, "Systèmes époxyde- Cuisson hors autoclave et basse température," Université de Toulouse, 2018.
- [29] Engineering Council, "UK-SPEC UK STANDARD FOR PROFESSIONAL ENGINEERING COMPETENCE," 2014.
- [30] S. P. Borgatti, M. G. Everett, and L. C. Freeman, "Ucinet for Windows: Software for Social Network Analysis." Analytic Technologies, Harvard, MA, 2002.
- [31] R. Helms, R. Ignacio, S. Brinkkemper, and A. Zonneveld, "Limitations of Network Analysis for Studying Efficiency and Effectiveness of Knowledge Sharing," vol. 8, no. 1, pp. 53–68, 2010.
- [32] M. Harrison, *Jobs and growth: the importance of engineering skills to the UK economy*, no. September. 2012.
- [33] L. R. Pickard, "Engineering the future," *Engineering Professors Council*, 2014. [Online]. Available: <http://epc.ac.uk/laura-pickard/>. [Accessed: 17-Jul-2018].
- [34] Advise Ltd, "Advise Deta." [Online]. Available: <https://www.advise-deta.com/en/>. [Accessed: 19-Jul-2018].
- [35] J. B. Enns and J. K. Gillham, "Time–temperature–transformation (TTT) cure diagram: Modeling the cure behavior of thermosets," *J. Appl. Polym. Sci.*, vol. 28, no. 8, pp. 2567–2591, Aug. 1983.
- [36] P. I. Karkanias and I. K. Partridge, "Cure modeling and monitoring of epoxy/amine resin systems. I. Cure kinetics modeling," *J. Appl. Polym. Sci.*, vol. 77, no. 7, pp. 1419–1431, Aug. 2000.
- [37] A. A. Skordos and I. K. Partridge, "Cure kinetics modeling of epoxy resins using a non-parametric numerical procedure," *Polym. Eng. Sci.*, vol. 41, no. 5, pp. 793–805, May 2001.
- [38] R. Hardis, J. L. P. P. Jessop, F. E. Peters, and M. R. Kessler, "Cure kinetics characterization and monitoring of an epoxy resin using DSC, Raman spectroscopy, and DEA," *Compos. Part A Appl. Sci. Manuf.*, vol. 49, pp. 100–108, Jun. 2013.
- [39] P. Hubert, A. Johnston, A. Poursartip, and K. Nelson, "Cure kinetics and viscosity models for Hexcel 8552 epoxy resin," in *International SAMPE symposium and exhibition*, 2001, no. May 2016, pp. 2341–2354.
- [40] A. T. DiBenedetto, "Prediction of the glass transition temperature of polymers: A model

- based on the principle of corresponding states," *J. Polym. Sci. Part B Polym. Phys.*, vol. 25, no. 9, pp. 1949–1969, Sep. 1987.
- [41] L. E. Nielsen, "Cross-Linking–Effect on Physical Properties of Polymers," *J. Macromol. Sci. Part C*, vol. 3, no. 1, pp. 69–103, Jan. 1969.
- [42] J. P. Pascault and R. J. J. Williams, "Glass transition temperature versus conversion relationships for thermosetting polymers," *J. Polym. Sci. Part B Polym. Phys.*, vol. 28, no. 1, pp. 85–95, 1990.
- [43] J. Kratz, T. Mesogitis, A. Skordos, I. Hamerton, and I. K. Partridge, "Developing Cure Kinetics Models for Interleaf Particle Toughened Epoxies," *SAMPE Conf. Proc.*, no. June, p. 13, 2016.
- [44] D. Van Ee and A. Poursartip, *HexPly 8552 MATERIAL PROPERTIES DATABASE for use with COMPRO CCA and Raven*. 2009.
- [45] M. J. Lodeiro and D. R. Mulligan, "Cure Monitoring Techniques for Polymer Composites, Adhesives and Coatings," no. 75, p. 109, 2005.
- [46] S. Konstantopoulos, E. Fauster, and R. Schledjewski, "Monitoring the production of FRP composites: A review of in-line sensing methods," *Express Polym. Lett.*, vol. 8, no. 11, pp. 823–840, 2014.
- [47] L. R. Pickard, K. Smith, J. Kratz, and K. Potter, "Tracking the Evolution of a Defect, Characteristic of Afp Layup, During Cure With in-Process Micro-Ct Scanning," in *Proceedings of the 20th International Conference on Composite Materials*, 2017, no. August, pp. 20–25.
- [48] J. Lambert, A. R. Chambers, I. Sinclair, and S. M. Spearing, "3D damage characterisation and the role of voids in the fatigue of wind turbine blade materials," *Compos. Sci. Technol.*, vol. 72, no. 2, pp. 337–343, Jan. 2012.
- [49] P. J. Schubel, R. J. Crossley, E. K. G. Boateng, and J. R. Hutchinson, "Review of structural health and cure monitoring techniques for large wind turbine blades," *Renew. Energy*, vol. 51, pp. 113–123, 2013.
- [50] L. R. Pickard, I. K. Partridge, and P. Shakspeare, "From Lab To Factory : a Knowledge Based Approach To Understanding and Lowering the Barriers To New Technology Uptake in Industry , As Applied To in- Process Monitoring of Composite Materials .," in *Proceedings of the 17th European Conference on Composite Materials*, 2016, no. June, pp. 26–30.
- [51] G. Kortaberria, P. Arruti, N. Gabilondo, and I. Mondragon, "Curing of an epoxy resin modified with poly(methylmethacrylate) monitored by simultaneous dielectric/near infrared

- spectroscopies," *Eur. Polym. J.*, vol. 40, no. 1, pp. 129–136, 2004.
- [52] K. Asami, "Characterization of heterogeneous systems by dielectric spectroscopy," *Prog. Polym. Sci.*, vol. 27, no. 8, pp. 1617–1659, 2002.
- [53] A. Battisti, A. A. Skordos, and I. K. Partridge, "Dielectric monitoring of carbon nanotube network formation in curing thermosetting nanocomposites," *J. Phys. D. Appl. Phys.*, vol. 42, no. 15, 2009.
- [54] INASCO, "INASCO - INtegrated Aerospace Sciences COrporation - Dielectric Sensors." [Online]. Available: [http://www.inasco.com/index.php?option=com\\_content&task=blogcategory&id=38&Itemid=96](http://www.inasco.com/index.php?option=com_content&task=blogcategory&id=38&Itemid=96). [Accessed: 19-Jul-2018].
- [55] Novocontrol, "Alpha-A Analyzer." [Online]. Available: [https://www.novocontrol.de/php/ana\\_alpha.php](https://www.novocontrol.de/php/ana_alpha.php). [Accessed: 19-Jul-2018].
- [56] NETZSCH, "DEA 288 Ionic - NETZSCH Analyzing & Testing." [Online]. Available: <https://www.netzsch-thermal-analysis.com/en/products-solutions/dielectric-analysis/dea-288-ionic/>. [Accessed: 19-Jul-2018].
- [57] Lambient Technologies, "Lambient Technologies." [Online]. Available: <https://lambient.com/sensors/>. [Accessed: 19-Jul-2018].
- [58] Y. Yang *et al.*, "Development of a Dielectric Sensor System for the On-line Cure Monitoring of Composites," *Procedia Technol.*, vol. 15, pp. 631–637, Jan. 2014.
- [59] R. Pethrick and D. Hayward, "Real time dielectric relaxation studies of dynamic polymeric systems," *Prog. Polym. Sci.*, vol. 27, no. 9, pp. 1983–2017, 2002.
- [60] A. M. Maffezzoli, L. Peterson, C. Seferis, J. Kenny, and L. Nicolais, "Dielectric Characterization of Water Sorption in Epoxy Resin Matrices," *Engineering*, vol. 33, no. 2, 1993.
- [61] S. A. Grammatikos, R. J. Ball, M. Evernden, and R. G. Jones, "Impedance spectroscopy as a tool for moisture uptake monitoring in construction composites during service," *Compos. Part A Appl. Sci. Manuf.*, vol. 105, pp. 108–117, Feb. 2018.
- [62] R. Raihan, J.-M. Adkins, J. Baker, F. Rabbi, and K. Reifsnider, "Relationship of dielectric property change to composite material state degradation," *Compos. Sci. Technol.*, vol. 105, pp. 160–165, Dec. 2014.
- [63] S. Dutta, "Water absorption and dielectric properties of Epoxy insulation," no. June, pp. 1–51, 2008.

- [64] C. Carlini, P. A. Rolla, and E. Tombari, "Measurement method and apparatus for monitoring the kinetics of polymerization and crosslinking reactions by microwave dielectrometry," *J. Appl. Polym. Sci.*, vol. 41, no. 34, pp. 805–818, 1990.
- [65] S. Carrozzino, G. Levita, P. Rolla, and E. Tombari, "Calorimetric and microwave dielectric monitoring of epoxy resin cure," *Polym. Eng. Sci.*, vol. 30, no. 6, pp. 366–373, Mar. 1990.
- [66] J. Methven and Y. Katramados, *In-line quality monitoring of pultruded profiles using dielectric measurements*, vol. 5. 1997.
- [67] J. Mijović *et al.*, "Impedance spectroscopy of reactive polymers. 3. Correlations between dielectric, spectroscopic, and rheological properties during cure of a trifunctional epoxy resin," *J. Polym. Sci. Part B Polym. Phys.*, vol. 34, no. 2, pp. 379–388, Jan. 1996.
- [68] J. Mijovic and C. F. W. Yee, "Use of Complex Impedance To Monitor the Progress of Reactions in Epoxy/Amine Model Systems," *Macromolecules*, vol. 27, pp. 7287–7293, 1994.
- [69] A. Maffezzoli, A. Trivisano, M. Opalicki, J. Mijovic, and J. M. K. Ny, "Correlation between dielectric and chemorheological properties during cure of epoxy-based composites," *J. Mater. Sci.*, vol. 29, pp. 800–808, 1994.
- [70] P. Tecchio, "Impedance Spectroscopy of Reactive Polymers . 3 . Correlations Between Dielectric , Spectroscopic , and Rheological Properties During Cure of a Trifunctional Epoxy Resin," 2001.
- [71] L. Núñez, S. Gómez-Barreiro, C. A. Gracia-Fernández, and M. R. Núñez, "Use of the dielectric analysis to complement previous thermoanalytical studies on the system diglycidyl ether of bisphenol A/1,2 diamine cyclohexane," *Polymer (Guildf)*., vol. 45, no. 4, pp. 1167–1175, 2004.
- [72] W. Stark, "Investigation of curing behaviour of melamine/phenolic (MP) thermosets," *Polym. Test.*, vol. 29, no. 6, pp. 723–728, 2010.
- [73] R. Casalini, S. Corezzi, A. Livi, G. Levita, and P. A. Rolla, "Dielectric parameters to monitor the crosslink of epoxy resins," *J. Appl. Polym. Sci.*, vol. 65, no. 1, pp. 17–25, Jul. 1997.
- [74] A. McIlhagger, D. Brown, and B. Hill, "Development of a dielectric system for the on-line cure monitoring of the resin transfer moulding process," *Compos. Part A Appl. Sci. Manuf.*, vol. 31, no. 12, pp. 1373–1381, 2000.
- [75] D. Abraham and R. Mcilhagger, "Glass fibre epoxy composite cure monitoring using parallel plate dielectric analysis in comparison with thermal and mechanical testing techniques," pp. 811–819, 1998.



- [76] S. Kobayashi, R. Matsuzaki, and A. Todoroki, "Multipoint cure monitoring of CFRP laminates using a flexible matrix sensor," *Compos. Sci. Technol.*, vol. 69, no. 3–4, pp. 378–384, 2009.
- [77] Lambient Technologies, "Application Note 2.07-Lambient Technologies TM Sensors, A/D Ratio and Base Capacitance," 2017. [Online]. Available: <http://www.lambient.com/theory/>. [Accessed: 19-Jul-2018].
- [78] S. D. Senturia, N. F. Sheppard, H. L. Lee, and D. R. Day, "In-situ Measurement of the Properties of Curing Systems with Microdielectrometry," *J. Adhes.*, vol. 15, no. 1, pp. 69–90, Nov. 1982.
- [79] S. D. Senturia and N. F. Sheppard, "Dielectric Analysis of Thermoset Cure," *Adv. Polym. Sci.*, p. 70, 1985.
- [80] R. Meier, S. Zaremba, F. Springl, K. Drechsler, F. Gaille, and C. Weimer, "ONLINE PROCESS MONITORING SYSTEMS – BENCHMARK AND TEST STUDY," in *Flow Processes in Composite Materials*, 2012.
- [81] Y. Yang *et al.*, "Design and fabrication of a flexible dielectric sensor system for in situ and real-time production monitoring of glass fibre reinforced composites," *Sensors Actuators, A Phys.*, vol. 243, pp. 103–110, 2016.
- [82] P. Van Gerwen *et al.*, "Nanoscaled interdigitated electrode arrays for biochemical sensors," *Sensors Actuators B Chem.*, vol. 49, no. 1–2, pp. 73–80, Jun. 1998.
- [83] J. S. Kim and D. G. Lee, "Analysis of dielectric sensors for the cure monitoring of resin matrix composite materials," *Sensors Actuators, B Chem.*, vol. 30, no. 2, pp. 159–164, 1996.
- [84] G. M. Maistros and I. K. Partridge, "Monitoring autoclave cure in commercial carbon fibre/epoxy composites," *Compos. Part B Eng.*, vol. 29, no. 3, pp. 245–250, Jan. 1998.
- [85] J. W. Gillespie, U. K. Vaidya, N. C. Jadhav, B. K. Fink, and M. V Hosur, "Assessment of flow and cure monitoring using direct current and alternating current sensing in vacuum-assisted resin transfer molding," *Smart Mater. Struct.*, vol. 9, pp. 727–736, 2000.
- [86] J. S. Chilles, A. F. Koutsomitopoulou, A. J. Croxford, and I. P. Bond, "Monitoring cure and detecting damage in composites with inductively coupled embedded sensors," *Compos. Sci. Technol.*, vol. 134, pp. 81–88, Oct. 2016.
- [87] U. Müller, C. Pretschuh, R. Mitter, and S. Knappe, "Dielectric analysis as a cure monitoring system for UF particle boards," *Int. J. Adhes. Adhes.*, vol. 73, pp. 45–50, 2017.
- [88] A. a. Skordos and I. K. Partridge, "Impedance cure and flow monitoring in the processing of

- advanced composites.," *Int. Conf. Manuf. Adv. Compos.*, pp. 1–10, 2001.
- [89] J. Jakobsen, A. Skordos, S. James, R. G. Correia, and M. Jensen, "In-situ Curing Strain Monitoring of a Flat Plate Residual Stress Specimen Using a Chopped Stand Mat Glass/Epoxy Composite as Test Material," *Appl. Compos. Mater.*, vol. 22, no. 6, pp. 805–822, 2015.
- [90] R. Polanský *et al.*, "Development of a measuring system for on-line in situ monitoring of composite materials manufacturing," *Compos. Part A Appl. Sci. Manuf.*, vol. 90, pp. 760–770, Nov. 2016.
- [91] H. G. Kim and D. G. Lee, "Dielectric cure monitoring for glass/polyester prepreg composites," *Compos. Struct.*, vol. 57, no. 1–4, pp. 91–99, 2002.
- [92] D. Boll, K. Schubert, C. Brauner, and W. Lang, "Miniaturized flexible interdigital sensor for in situ dielectric cure monitoring of composite materials," *IEEE Sens. J.*, vol. 14, no. 7, pp. 2193–2197, 2014.
- [93] M. Kahali Moghaddam *et al.*, "Design, fabrication and embedding of microscale interdigital sensors for real-time cure monitoring during composite manufacturing," *Sensors Actuators A Phys.*, vol. 243, pp. 123–133, Jun. 2016.
- [94] M. C. Kazilas, "Acquisition and Interpretation of Dielectric Data For Thermoset Cure Monitoring," Cranfield University, 2003.
- [95] G. M. Maistros and C. B. Bucknall, "Modeling the dielectric behavior of epoxy resin blends during curing," *Polym. Eng. Sci.*, vol. 34, no. 20, pp. 1517–1528, Oct. 1994.
- [96] D. R. Day, T. J. Lewis, H. L. Lee, and S. D. Senturia, "The Role of Boundary Layer Capacitance at Blocking Electrodes in the Interpretation of Dielectric Cure Data in Adhesives," *J. Adhes.*, vol. 18, no. 1, pp. 73–90, Jan. 1985.
- [97] G. M. Maistros and I. K. Partridge, "DIELECTRIC CARBON-FIBRE COMPOSITE," vol. 53, pp. 355–359, 1995.
- [98] F. Bellucci *et al.*, "Impedance spectroscopy of reactive polymers. 2. Multifunctional epoxy/amine formulations," *J. Polym. Sci. Part B Polym. Phys.*, vol. 33, no. 3, pp. 433–443, Feb. 1995.
- [99] S. Bidstrup and D. Day, "Assignment of the Glass Transition Temperature Using Dielectric Analysis: A Review," *ASTM STP 1249*, pp. 108–119, 1994.
- [100] F. BELLUCCI *et al.*, "Impedance spectroscopy of reactive polymers. 1," *J. Polym. Sci. Part B Polym. Phys.*, vol. 32, no. 15, pp. 2519–2527, Nov. 1994.

- [101] P. I. Karkanis, "Cure Modelling and Monitoring of Epoxy / Amine Resin Systems (PhD-Thesis)," no. March, 1998.
- [102] D. Boll, K. Schubert, C. Brauner, and W. Lang, "Miniaturized Flexible Interdigital Sensor for *In Situ* Dielectric Cure Monitoring of Composite Materials," *IEEE Sens. J.*, vol. 14, no. 7, pp. 2193–2197, Jul. 2014.
- [103] K. Nixdorf and G. Busse, "The dielectric properties of glass-fibre-reinforced epoxy resin during polymerisation," *Compos. Sci. Technol.*, vol. 61, no. 6, pp. 889–894, May 2001.
- [104] G. M. Maistros and C. B. Bucknall, "Resin Blends During Curing," *Polym. Eng. Sci.*, vol. 34, no. 20, pp. 1517–1528, 1994.
- [105] A. A. Skordos and I. K. Partridge, "Determination of the degree of cure under dynamic and isothermal curing conditions with electrical impedance spectroscopy," *J. Polym. Sci. Part B Polym. Phys.*, vol. 42, no. 1, pp. 146–154, 2004.
- [106] L. H. Garden, D. Hayward, and R. A. Pethrick, "Dielectric non-destructive testing approach to cure monitoring of adhesives and composites," *Proc. Inst. Mech. Eng. Part G J. Aerosp. Eng.*, vol. 221, no. 4, pp. 521–533, 2007.
- [107] Y. A. Tajima, "Monitoring cure viscosity of epoxy composite," *Polym. Compos.*, vol. 3, no. 3, pp. 162–169, Jul. 1982.
- [108] Lambient Technologies, "Applications Note 2.11-Lambient Technologies TM Measuring Degree of Cure with DEA," 2017.
- [109] J. Mijovic, J. M. Kenny, A. Maffezzoli, A. Trivisano, and F. Bellucci, "THE PRINCIPLES OF DIELECTRIC MEASUREMENTS FOR IN SITU MONITORING OF COMPOSITE PROCESSING," vol. 49, pp. 277–290, 1993.
- [110] K. S. Cole and R. H. Cole, "Dispersion and Absorption in Dielectrics I. Alternating Current Characteristics," *J. Chem. Phys.*, vol. 9, no. 4, pp. 341–351, Apr. 1941.
- [111] A. J. MacKinnon, S. D. Jenkins, P. T. McGrail, and R. A. Pethrick, "Dielectric, mechanical and rheological studies of phase separation and cure of a thermoplastic modified epoxy resin: incorporation of reactively terminated polysulfones," *Polymer (Guildf.)*, vol. 34, no. 15, pp. 3252–3263, 1993.
- [112] S. Poncet *et al.*, "Monitoring phase separation and reaction advancement in situ in thermoplastic/epoxy blends," *Polymer (Guildf.)*, vol. 40, no. 24, pp. 6811–6820, 1999.
- [113] M. C. Kazilas and I. K. Partridge, "Exploring equivalence of information from dielectric and

- calorimetric measurements of thermoset cure—a model for the relationship between curing temperature, degree of cure and electrical impedance,” *Polymer (Guildf)*., vol. 46, no. 16, pp. 5868–5878, Jul. 2005.
- [114] M. Despeisse, P. D. Ball, and S. Evans, “IDENTIFYING IMPROVEMENT OPPORTUNITIES TOWARDS SUSTAINABLE MANUFACTURING,” in *Proceedings of the International Manufacturing Conference (IMC28)*, 2011.
- [115] J. Fabris and A. Poursartip, “Knowledge in Practice: The Next Step in Reducing Risk in Composites Manufacturing and Design,” in *Design, Manufacturing and Applications of Composites Tenth Workshop 2014: Proceedings of the Tenth Joint Canada-Japan Workshop on Composites*, 2014.
- [116] A. Breede, M. K. Moghaddam, C. Brauner, A. S. Herrmann, and W. Lang, “Online Process Monitoring and Control By Dielectric Sensors for a Composite Main Spar for,” in *20th International Conference on Composite Materials*, 2011, no. July.
- [117] G. Chiesura *et al.*, “RTM production monitoring of the A380 hinge armdroop nose mechanism: A multi-sensor approach,” *Sensors (Switzerland)*, vol. 16, no. 6, pp. 1–17, 2016.
- [118] J. M. Lawrence *et al.*, “An approach to couple mold design and on-line control to manufacture complex composite parts by resin transfer molding,” *Compos. Part A Appl. Sci. Manuf.*, vol. 33, no. 7, pp. 981–990, Jul. 2002.
- [119] C. Garschke, C. Weimer, P. P. Parlevliet, and B. L. Fox, “Out-of-autoclave cure cycle study of a resin film infusion process using in situ process monitoring,” *Compos. Part A Appl. Sci. Manuf.*, vol. 43, no. 6, pp. 935–944, Jun. 2012.
- [120] K.-T. Hsiao, “Embedded single carbon fibre to sense the thermomechanical behavior of an epoxy during the cure process,” *Compos. Part A Appl. Sci. Manuf.*, vol. 46, pp. 117–121, Mar. 2013.
- [121] N. Pantelalis *et al.*, “Industrial cure monitoring and control of the RTM production of a CFRP automotive component,” in *ECCM15-15 TH EUROPEAN CONFERENCE on Composite Materials*, 2012.
- [122] N. Pantelalis and T. Millar, “In-situ process monitoring and quality control for advanced liquid composite moulding,” in *International Conference for Manufacturing of Advanced Composites*, 2011.
- [123] “What’s an Econoclave - ASC Process Systems.” [Online]. Available: <http://www.aschome.com/index.php/en/products/autoclaves/whats-an-econoclave>.

[Accessed: 08-Jul-2018].

- [124] K.-T. Hsiao, R. Little, O. Restrepo, and B. Minaie, "A study of direct cure kinetics characterization during liquid composite molding," *Compos. Part A Appl. Sci. Manuf.*, vol. 37, no. 6, pp. 925–933, Jun. 2006.
- [125] R. Vodicka, "Cure monitoring techniques using embedded sensors," 1997.
- [126] G. F. Fernando, "Fibre optic sensor systems for monitoring composite structures," *Reinf. Plast.*, vol. 49, no. 11, pp. 41–49, Dec. 2005.
- [127] L. Wang, S. Pandita, V. R. Machavaram, S. Malik, D. Harris, and G. F. Fernando, "Characterisation of the cross-linking process in an E-glass fibre/epoxy composite using evanescent wave spectroscopy," *Compos. Sci. Technol.*, vol. 69, no. 13, pp. 2069–2074, Oct. 2009.
- [128] L. Wang *et al.*, "In-situ monitoring of cross-linking reactions using E-glass fibres and evanescent wave spectroscopy," *Sensors Actuators B Chem.*, vol. 236, pp. 358–366, Nov. 2016.
- [129] J. S. Chilles, A. Croxford, and I. P. Bond, "Design of an embedded sensor, for improved structural performance," *Smart Mater. Struct.*, vol. 24, no. 11, p. 115014, Nov. 2015.
- [130] R. E. Challis *et al.*, "Epoxy Cure Observed By Ultrasound, Nmr and WAXS," no. January 1999, 1999.
- [131] R. E. Challis *et al.*, "Following Network Formation in an Epoxy / Amine System by Ultrasound , Dielectric , and Nuclear Magnetic Resonance Measurements : A Comparative Study," *J. Appl. Polym. Sci.*, 2002.
- [132] D. D. Shepard, K. R. Smith, and D. C. Maurer, "A Comparison of Dielectric and Ultrasonic Cure Monitoring of Advanced Composites," *Nondestruct. Charact. Mater. VIII*, pp. 383–392, 1998.
- [133] N. Liebers, F. Raddatz, and F. Schadow, "Effective and flexible ultrasound sensors for cure monitoring for industrial composite production," *Dtsch. Luft- und Raumfahrtkongress 2012*, vol. 9, 2012.
- [134] A. Thompson, I. Maskery, and R. K. Leach, "X-ray computed tomography for additive manufacturing: a review."
- [135] J. Rueckel, M. Stockmar, F. Pfeiffer, and J. Herzen, "Spatial resolution characterization of a X-ray microCT system," *Appl. Radiat. Isot.*, vol. 94, pp. 230–234, Dec. 2014.
- [136] S. C. Garcea, Y. Wang, and P. J. Withers, "X-ray computed tomography of polymer

- composites," *Compos. Sci. Technol.*, vol. 156, pp. 305–319, Mar. 2018.
- [137] E. Maire and P. J. Withers, "Quantitative X-ray tomography," *Int. Mater. Rev.*, vol. 59, no. 1, pp. 1–43, Jan. 2014.
- [138] J. M. Cole *et al.*, "Laser-wakefield accelerators as hard x-ray sources for 3D medical imaging of human bone," *Sci. Rep.*, vol. 5, no. 1, p. 13244, Oct. 2015.
- [139] A. G. Stamopoulos, K. I. Tserpes, P. Prucha, and D. Vavrik, "Evaluation of porosity effects on the mechanical properties of carbon fiber-reinforced plastic unidirectional laminates by X-ray computed tomography and mechanical testing."
- [140] F. Borges de Oliveira, A. Stolfi, M. Bartscher, L. De Chiffre, and U. Neuschaefer-Rube, "Experimental investigation of surface determination process on multi-material components for dimensional computed tomography," *Case Stud. Nondestruct. Test. Eval.*, vol. 6, pp. 93–103, Nov. 2016.
- [141] Volume Graphics, "VGStudio MAX 2.2 Reference Manual." 2013.
- [142] J. Kastner, B. Plank, D. Salaberger, and J. Sekelja, "Defect and Porosity Determination of Fibre Reinforced Polymers by X-ray Computed Tomography," *NDT Aerosp. 2010 - We.1.A.2*, no. January, pp. 1–12, 2010.
- [143] D. J. Bull, S. M. Spearing, and I. Sinclair, "Observations of damage development from compression-after-impact experiments using ex situ micro-focus computed tomography," *Compos. Sci. Technol.*, vol. 97, pp. 106–114, Jun. 2014.
- [144] S. C. Garcea, I. Sinclair, and S. M. Spearing, "In situ synchrotron tomographic evaluation of the effect of toughening strategies on fatigue micromechanisms in carbon fibre reinforced polymers," *Compos. Sci. Technol.*, vol. 109, pp. 32–39, Mar. 2015.
- [145] J. Vilà, F. Sket, F. Wilde, G. Requena, C. González, and J. LLorca, "An in situ investigation of microscopic infusion and void transport during vacuum-assisted infiltration by means of X-ray computed tomography," *Compos. Sci. Technol.*, vol. 119, pp. 12–19, 2015.
- [146] A. E. Scott, M. Mavrogordato, P. Wright, I. Sinclair, and S. M. Spearing, "In situ fibre fracture measurement in carbon–epoxy laminates using high resolution computed tomography," *Compos. Sci. Technol.*, vol. 71, no. 12, pp. 1471–1477, Aug. 2011.
- [147] J. Thompson *et al.*, "Micro-Computed Tomographic Synchrotron Techniques for Non-destructive Testing of out of Autoclave Composite Materials," in *Design, manufacturing and applications of composites : proceedings of the Tenth Joint Canada-Japan Workshop on*

- Composites*, 2014, pp. 331–335.
- [148] D. Ferré Sentis, L. Orgéas, P. J. J. Dumont, S. Rolland Du Roscoat, M. Sager, and P. Latil, “3D in situ observations of the compressibility and pore transport in Sheet Moulding Compounds during the early stages of compression moulding,” *Compos. Part A Appl. Sci. Manuf.*, vol. 92, pp. 51–61, Jan. 2017.
- [149] S. D. Keyes, F. Gillard, N. Soper, M. N. Mavrogordato, and I. Sinclair, “Mapping soil deformation around plant roots using in vivo 4D X-ray computed tomography and digital volume correlation.”
- [150] B. Plank, R. Helmus, M. Gschwandtner, R. M. Hinterhölzl, and J. Kastner, “In-Situ Observation of Bubble Formation in Neat Resin during the Curing Process by Means of X-Ray Computed Tomography,” in *19th World Conference on Non-Destructive Testing*, 2016, pp. 1–8.
- [151] J. P.-H. Belnoue *et al.*, “Understanding and predicting defect formation in automated fibre placement pre-preg laminates,” *Compos. Part A Appl. Sci. Manuf.*, vol. 102, pp. 196–206, Nov. 2017.
- [152] D. H.-J. a Lukaszewicz, “Optimisation of high-speed automated layup of thermoset carbon-fibre preimpregnates,” no. April, p. 215, 2011.
- [153] Y. M. Elsherbini and S. V Hoa, “Experimental and numerical investigation of the effect of gaps on fatigue behavior of unidirectional carbon/epoxy automated fiber placement laminates,” *J. Compos. Mater.*, vol. 51, no. 6, pp. 759–772, 2017.
- [154] A. T. Rhead, T. J. Dodwell, and R. Butler, “THE EFFECT OF TOW GAPS ON COMPRESSION AFTER IMPACT STRENGTH OF AFP LAMINATES,” in *Proceedings of the 15th European Conference on Composite Materials*, 2012.
- [155] K. Croft, L. Lessard, D. Pasini, M. Hojjati, J. Chen, and A. Yousefpour, “Experimental study of the effect of automated fiber placement induced defects on performance of composite laminates,” *Compos. Part A Appl. Sci. Manuf.*, vol. 42, no. 5, pp. 484–491, May 2011.
- [156] X. Li, S. R. Hallett, and M. R. Wisnom, “Modelling the effect of gaps and overlaps in automated fibre placement (AFP)-manufactured laminates,” *Sci. Eng. Compos. Mater.*, vol. 22, no. 2, pp. 115–129, Jan. 2015.
- [157] L. K. Grunenfelder, “DEFECT CONTROL IN VACUUM BAG ONLY PROCESSING OF COMPOSITE Epigraph,” no. December, 2012.
- [158] L. Liu, B.-M. Zhang, D.-F. Wang, and Z.-J. Wu, “Effects of cure cycles on void content and

- mechanical properties of composite laminates,” *Compos. Struct.*, vol. 73, no. 3, pp. 303–309, Jun. 2006.
- [159] J. R. Wood and M. G. Bader, “Void control for polymer-matrix composites (1): Theoretical and experimental methods for determining the growth and collapse of gas bubbles,” *Compos. Manuf.*, vol. 5, no. 3, pp. 139–147, Sep. 1994.
- [160] B. de Parscau du Plessix, S. Le Corre, F. Jacquemin, P. Lefebure, and V. Sobotka, “Improved simplified approach for the prediction of porosity growth during the curing of composites parts,” *Compos. Part A Appl. Sci. Manuf.*, vol. 90, pp. 549–558, Nov. 2016.
- [161] L. K. Grunenfelder and S. R. Nutt, “Void formation in composite prepregs – Effect of dissolved moisture,” *Compos. Sci. Technol.*, vol. 70, no. 16, pp. 2304–2309, Dec. 2010.
- [162] P. F. Drucker, *Landmarks of Tomorrow*. William Heinemann Ltd, 1959.
- [163] P. F. Drucker, *The Age of Discontinuity; Guidelines to Our Changing Society*. William Heinemann Ltd, 1969.
- [164] S. Regoczei and E. P. O. Plantinga, “Creating the domain of discourse: ontology and inventory,” *Int. J. Man. Mach. Stud.*, 1987.
- [165] C. Zins, “Writing information literacy assessment plans: A guide to best practice,” *Commun. Inf. Lit.*, vol. 3, no. 2, pp. 80–90, 2009.
- [166] J. Scott, *Social network analysis*, 3rd ed. Sage publications Ltd, 1991.
- [167] D. Leonard and W. Swap, *Deep smarts: How to cultivate and transfer enduring business wisdom*. Harvard Business School Press, 2005.
- [168] T. H. Davenport and L. Prusak, *Working Knowledge: How Organizations Manage What They Know*. Harvard Business School Press, 1998.
- [169] H. Ghaziri and E. Awad, “IS THERE A FUTURE FOR KNOWLEDGE MANAGEMENT? Journal of Information Technology Management IS THERE A FUTURE FOR KNOWLEDGE MANAGEMENT?,” *J. Inf. Technol. Manag.*, vol. XVI, no. 1, 2005.
- [170] S. Joel-Edgar and J. Gopsill, “Understanding User Requirements in Context: A Case Study of Developing a Visualisation Tool to Map Skills in an Engineering Organisation,” in *International Conference on Information Management and Processing*, 2018, p. 5.
- [171] Y. Barnard and A. Rothe, “Knowledge Management in engineering: supporting analysis and design processes in innovative industries,” *Knowl. Manag.*, pp. 931–938, 2003.



- [172] M. Hansen, N. Nohria, and T. Tierney, "What 's Your Strategy for Managing Knowledge?," *Harv. Bus. Rev.*, vol. 72, no. 2, pp. 106–116, 1999.
- [173] S. Burnett, D. Williams, and A. Grinnall, "The Strategic Role of Knowledge Auditing and Mapping: An Organisational Case Study," *Proc. Eur. Conf. Knowl. Manag. ECKM*, vol. 20, no. 3, pp. 541–546, 2007.
- [174] S. Nousala, A. Miles, B. Kilpatrick, and W. P. Hall, "Building knowledge sharing communities using team expertise access maps," *Int. J. Bus. Syst. Res.*, vol. 3, no. 3, p. 279, 2009.
- [175] R. W. Helms and J. van Reijssen, "Impact of Knowledge Network Structure on Group Performance of Knowledge Workers in a Product Software Company.," *Proc. 9th Eur. Conf. Knowl. Manag.*, vol. 2, no. September, pp. 289–296, 2008.
- [176] A. Moteleb and M. Woodman, "Notions of knowledge management systems: A gap analysis," ... *J. Knowl. Manag.*, vol. 5, no. 1, pp. 55–62, 2007.
- [177] S. Sharwood, "T'was the night before Christmas, and an industrial control system needed an upgrade • The Register," *The Register*, 2015. [Online]. Available: [https://www.theregister.co.uk/2015/12/18/twas\\_the\\_night\\_before\\_christmas\\_and\\_an\\_industrial\\_control\\_system\\_needed\\_an\\_upgrade/](https://www.theregister.co.uk/2015/12/18/twas_the_night_before_christmas_and_an_industrial_control_system_needed_an_upgrade/). [Accessed: 30-Aug-2018].
- [178] S. Sharwood, "The developer died 14 years ago, here's a print out of his source code • The Register," *The Register*, 2016. [Online]. Available: [https://www.theregister.co.uk/2016/08/05/on\\_call\\_netware\\_hell/](https://www.theregister.co.uk/2016/08/05/on_call_netware_hell/). [Accessed: 30-Aug-2018].
- [179] P. M. Senge, *The Fifth Discipline. The Art & Practice of The Learning Organisation*, 2nd ed. Random House Business Books, 1990.
- [180] M. K. Mason, "What is a Learning Organization?," 2011. [Online]. Available: <http://www.moyak.com/papers/learning-organization.html>. [Accessed: 01-Mar-2019].
- [181] D. A. Garvin, "Building a Learning Organization," *Harvard Business Review*, 1993. [Online]. Available: <https://hbr.org/1993/07/building-a-learning-organization>. [Accessed: 01-Mar-2019].
- [182] D. A. Garvin, A. C. Edmondson, and F. Gino, "Is Yours a Learning Organization? - Harvard Business Review," *Harv. Bus. Rev.*, no. August, pp. 1–10, 2008.
- [183] B. Sugarman, "A LEARNING-BASED APPROACH TO ORG. CHANGE: Five Case Studies A LEARNING-BASED APPROACH TO ORGANIZATIONAL CHANGE: FIVE CASE STUDIES OF GUIDED CHANGE INITIATIVES," 2000.

- [184] T. Levantakis, R. Helms, and M. Spruit, "Developing a reference method for knowledge auditing," pp. 147–159, 2008.
- [185] N. S. A. Shukor, A. A. Rahman, and N. A. Iahad, "A review on knowledge audit process," *Proc. - Pacific Asia Conf. Inf. Syst. PACIS 2013*, 2013.
- [186] A. Perez-Soltero, M. Barcelo-Valenzuela, G. Sanchez-Schmitz, F. Martin-Rubio, and J. T. Palma-Mendez, "Knowledge Audit Methodology," *Eur. Mediterr. Conf. Inf. Syst.*, pp. 1–10, 2006.
- [187] M. Levy, I. Hadar, and I. Aviv, "Enhancing Knowledge-Intensive Business Processes via Knowledge Management Audit," in *Proceedings of the fifteenth Americas Conference on Information Systems*, 2009, pp. 1–10.
- [188] A. Perez-Soltero, R. Alvarez-Quijada, M. Barcelo-Valenzuela, and A. Diaz-Valladares, "A Methodology for Documenting Key Knowledge Through the Application of Knowledge Audit Techniques : The Case of a Mexican Pulp Company," *IUP J. Knowl. Manag.*, vol. 11, no. 3, pp. 7–28, 2013.
- [189] H. S. A. Nawawi, N. S. A. Shukor, S. Basaruddin, N. Md Rahim, R. Abu Hassan, and K. Jusoff, "Determining The Existence Of Knowledge Management Processes Among Academicians," *J. Knowl. Manag. Pract.*, vol. 13, no. 2, pp. 1–7, 2012.
- [190] D. W. Hubbard, *How To Measure Anything: Finding the Value of "Intangibles" in Business*, 2nd ed. John Wiley & Sons, Inc, 2010.
- [191] R. Cross, S. P. Borgatti, and A. Parker, "Making Invisible Work Visible: Using Social Network Analysis to Support Strategic Collaboration," *Calif. Manage. Rev.*, vol. 44, no. 2, pp. 25–46, 2002.
- [192] Gephi.org, "Gephi - The Open Graph Viz Platform." .
- [193] S. Brin and L. Page, "The PageRank Citation Ranking: Bringing Order to the Web," in *Proceedings of the seventh international conference on World Wide Web*, 1998.
- [194] S. Brin, L. Page, S. Brin, and L. Page, "The anatomy of a large-scale hypertextual Web search engine," *Comput. Networks ISDN Syst.*, vol. 30, no. 1–7, pp. 107–117, Apr. 1998.
- [195] W. Xing and A. Ghorbani, "Weighted PageRank algorithm," in *Proceedings. Second Annual Conference on Communication Networks and Services Research, 2004.*, 2004, pp. 305–314.
- [196] P. J. McSweeney and S. Heymann, "PageRank.java," *Gephi.org*, 2011. [Online]. Available: <https://github.com/gephi/gephi/blob/master/modules/StatisticsPlugin/src/main/java/org/ge>

phi/statistics/plugin/PageRank.java.

- [197] J. M. Kleinberg, "Authoritative Sources in a Hyperlinked Environment \*," 1998.
- [198] V. D. Blondel, J.-L. Guillaume, R. Lambiotte, and E. Lefebvre, "Fast unfolding of communities in large networks," 2008.
- [199] M. Feltham-lauzon, "HEC MONTRÉAL Para Public Entities as Anchor Organizations in Industrial Clusters par," 2018.
- [200] F. Salie, · Kylie De Jager, C. Dreher, and T. S. Douglas, "The scientific base for orthopaedic device development in South Africa: spatial and sectoral evolution of knowledge development," *Scientometrics*, vol. 119, pp. 31–54, 2019.
- [201] A. S. García Muñiz and M. R. V. Cuervo, "Exploring research networks in Information and Communication Technologies for energy efficiency: An empirical analysis of the 7th Framework Programme," *J. Clean. Prod.*, vol. 198, pp. 1133–1143, Oct. 2018.
- [202] J. Mateos-Garcia and H. Bakhshi, "The Geography of Creativity in the UK Creative clusters, creative people and creative networks The Geography of Creativity in the UK," 2016.
- [203] O. Plum and R. Hassink, "Comparing knowledge networking in different knowledge bases in Germany\*," *Pap. Reg. Sci.*, vol. 90, no. 2, pp. 355–371, Jun. 2011.
- [204] M. Abbasiharofteh and W. Dyba, "Structure and significance of knowledge networks in two low-tech clusters in Poland," *Reg. Stud. Reg. Sci.*, vol. 5, no. 1, pp. 108–116, 2018.
- [205] N. Hjertvikrem and R. Dahl Fitjar, "Knowledge networks and innovation among subsea firms," in *Petroleum industry transformations : lessons from Norway and beyond*, T. Thune, O. Wicken, and O. A. Engen, Eds. Routledge, 2018, pp. 58–69.
- [206] G. A. Mcdermott, R. A. Corredoira, and G. Kruse, "PUBLIC-PRIVATE INSTITUTIONS AS CATALYSTS OF UPGRADING IN EMERGING MARKET SOCIETIES," *Acad. Manag. J.*, vol. 52, no. 6, pp. 1270–1296, 2009.
- [207] A. P. Chatzimichali and K. D. Potter, "From composite material technologies to composite products: a cross-sectorial reflection on technology transitions and production capability," *Transl. Mater. Res.*, vol. 2, no. 2, p. 026001, Jul. 2015.
- [208] J. Fabris, D. Roughley, A. Poursartip, and E. Maine, "Managing the technological and market uncertainty of composites innovation: a case study of composites manufacturers in Western Canada and interventions by a translational research centre," *Transl. Mater. Res.*, vol. 4, no. 4, p. 046001, Nov. 2017.

- [209] E. Maine and P. Seegopaul, "Accelerating advanced-materials commercialization," *Nat. Mater.*, vol. 15, no. 5, pp. 487–491, May 2016.
- [210] C. López-Gómez, "UK's post-Brexit economy hinges on small businesses and innovation," *Institute for Manufacturing*, 2017. [Online]. Available: <https://www.ifm.eng.cam.ac.uk/news/uks-post-brexit-economy-hinges-on-sme-innovation/>. [Accessed: 10-Jul-2018].
- [211] Dowling, "The Dowling Review of Business-University Research Collaborations," 2015.
- [212] M. H. Zack, "Managing Codified Knowledge," *MITSloan Manag. Rev.*, 1999.
- [213] T. Minshall, "Skills pose major barrier to additive manufacturing adoption - The Manufacturer," *The Manufacturer*. [Online]. Available: <https://www.themanufacturer.com/articles/skills-major-barrier-to-additive-manufacturing-adoption/>. [Accessed: 10-Jul-2018].
- [214] J. Perkins, "Professor John Perkins ' Review of Engineering Skills," *EPC Congr.*, vol. 44, no. November, p. 15, 2014.
- [215] M. C. Kazilas, A. A. Skordos, and I. K. Partridge, "Parameter estimation in equivalent circuit analysis of dielectric cure monitoring signals using genetic algorithms," *Inverse Probl. Sci. Eng.*, vol. 13, no. 2, pp. 157–176, 2005.
- [216] European Commission, "Technology Readiness Levels." Horizon 2020, 2014.
- [217] European Commission, "Definition of Small and Medium Size Enterprises." [Online]. Available: [http://ec.europa.eu/growth/smes/business-friendly-environment/sme-definition\\_en](http://ec.europa.eu/growth/smes/business-friendly-environment/sme-definition_en).
- [218] R. A. Hanneman and M. Riddle, *Introduction to Social Network Methods*. Riverside, California: <http://faculty.ucr.edu/~hanneman/nettext/index.html>, 2005.
- [219] Gephi, "Learn how to use Gephi." [Online]. Available: <https://gephi.org/users/>. [Accessed: 28-Aug-2018].
- [220] R. Helms and K. Buijsrogge, "Application of knowledge network analysis to identify knowledge sharing bottlenecks at an engineering firm," in *Proceedings of the 14th European Conference on Information Systems, ECIS 2006*, 2006, pp. 1–13.
- [221] M. Škerlavaj, V. Dimovski, A. Mrvar, and & M. Pahor, "Intra-organizational learning networks within knowledge-intensive learning environments," *Interact. Learn. Environ.*, vol. 18, no. 1, pp. 39–63, 2010.

- [222] R. W. Helms, "Redesigning communities of practice using knowledge network analysis," *Hands-On Knowl. Co-Creation Shar. Pract. Methods Tech.*, pp. 251–274, 2007.
- [223] Nikon, "XT H 320 | Computed Tomography | X-ray and CT inspection | Nikon Metrology." [Online]. Available: <https://www.nikonmetrology.com/en-gb/product/xt-h-320>. [Accessed: 02-Oct-2018].
- [224] "RAVEN 3 Examples," 2013. [Online]. Available: [http://www.convergent-mfg.com/sites/default/files/fm/raven\\_examples.pdf](http://www.convergent-mfg.com/sites/default/files/fm/raven_examples.pdf). [Accessed: 06-Jun-2018].
- [225] Synthesites, "Synthesites: Cure monitoring Technology -." [Online]. Available: <https://www.synthesites.com/page.php?p=22>. [Accessed: 05-Jul-2018].
- [226] UKPower.co.uk, "Energy Comparison | Compare Gas & Electric Prices | UKPower." [Online]. Available: <https://www.ukpower.co.uk/>. [Accessed: 02-Oct-2018].
- [227] I. K. Partridge and P. Smart, "Cure monitoring of composite structures - in search of the missing link !," 2008. [Online]. Available: <https://gtr.ukri.org/projects?ref=EP%2FF012489%2F1>. [Accessed: 01-Oct-2018].



3) This question asks you to rate your level of expertise in different areas.

It is split into **theory** and **practical**, to allow for the possibility that some of the best practical experimenters may not have studied the theory in depth, whereas a leading Professor would certainly be a level 5 in theory but might not be up to date with the latest practical tools and techniques.

For simulation, the split is as follows:

**Theory**- background understanding, mathematics and theory of techniques e.g. finite element analysis, fluid dynamics. **Practical**- getting useful output from commercial program or writing your own code

Level	
0: Complete beginner	No experience or knowledge of this at all.
1: Novice	I have heard of this but only just started working on it.
2: Capable	Solid understanding of the basics/I do the work reliably and confidently
3: Advanced	Detailed understanding/practical work on non-standard setups
4: Expert	Can answer almost any question/can make new methods, tools or experiments
5: World Class	World leading expert. Wrote the book/designed and built the machine.

	Theory	Practical
Mould/Jig Building		
Thermoforming		
Quality standards		
Hand layup of prepreg		
Autoclave operation		
Air voids control		
Cracks control		
Automated Fibre Placement		
Dry fibre preforms		
Resin degassing		
Resin infusion		
Trim and Grind		
Raw materials performance		
Curing process		
Mechanical test machines		
Drape simulation		

Please make any notes, comments and suggestions that you specifically DO NOT want to be anonymous here. Anonymous suggestions can be made in the next section.

Age: \_\_\_\_\_  
Please give a decade, e.g. 30s, 40s.

Job: \_\_\_\_\_  
Please mark on the diagram where the bulk of your work lies

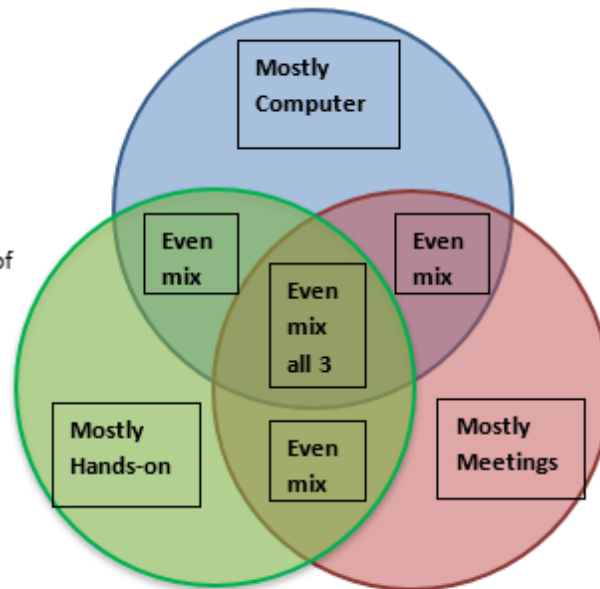

**Reminder: Your answers to these questions are completely anonymous so please be honest.**

4) When you need to know something, who/what do you turn to first? Rank 1<sup>st</sup> to last, leave blank anything you never use.

	Specific question/ fault	General understanding
Web search		
Online forums		
Organisation intranet		
Manuals or manufacturer's guides		
Manufacturer helpline/support		
Academic papers		
Supervisor/team leader		
Other colleagues at your organisation		
Researchers at universities		
Partners from industrial projects		
External experts		
Attending conferences or seminars		

5) During a project, do you/your team do any of the following? Please answer Y/N or S (sometimes).

- Begin with a search for relevant knowledge.
- Seek out experts.
- Produce a literature survey.
- Keep a note of useful tips/tricks.
- Record raw data.
- Record conclusions drawn from this.
- Discuss what you have learned at project milestones/end.
- Write down said lessons.
- Refer to them during subsequent projects.]



6) Which of the current forms of knowledge transfer, as implemented at your organisation, work well for you?

Question	Useless -----V. Useful				
	1	2	3	4	5
Team Meetings					
Mentoring					
On the job learning					
Attending conferences					
Casual discussion in office/common room/over a cup of tea					
Intranet/Internal Network					
Standard Operating Procedures					
Supplier visits					
E-mails					
Manuals					
Courses					
Library					

7) Please list your level of agreement with the following statements:

Question	Disagree -----Agree				
	1	2	3	4	5
My organisation's current knowledge management practices work well					
I know where to go when I need help					
I know who the experts in the topics/tools I work with are					
I need to increase my knowledge in order to do my job					

8) How likely would you be to use each of the following options, if they were available?

Question	Unlikely -----V. Likely				
	1	2	3	4	5
Formal training courses					
Mentoring programme					
Intranet based wiki for useful info and links to detailed theory					
External internet based knowledge repository					
Intranet based discussion forums/groups					
Open/external discussion forums/groups					
Directory of experts					
Library of relevant books/academic papers					
Central store of manuals/how to documentation					

Realistically, how often would you be willing- and have time- to add nuggets of information to a wiki or answer questions in a discussion forum?

Daily      Weekly      Monthly      Yearly      Never

Please write any comments, queries or suggestions you may have about knowledge management in your organisation below- or email [REDACTED]

## Appendix 2: Steps in Void analysis macro

- Open .vgi reconstruction file
- Apply a median filter (level 5) to the reconstruction, which smooths greyscale values over 5 voxels. This helps to remove noise, and is at too small a scale to affect the void sizes measured.
- Use VG Studio's surface determination tool to automatically locate surfaces- this uses changes in density to find the surfaces of the object being scanned, including inner surfaces around voids and gaps.
- Define a region of interest from this surface.
- Invert the region of interest, so that the gaps and voids are 'inside'.
- Extract this region of interest, containing the gaps.
- Apply the previously defined region of interest template to this extracted region.
- Extract the resulting region. We now have a volume consisting only of the gaps and voids in the defined zone.
- Use VG studio's void analysis tool (set to "only threshold" to detect voids as we now have a simple volume of voids only) to measure all these gaps and voids. Voids of volume 0.01 to 100 mm<sup>3</sup>, with a probability of 0.1 or more, are measured. This means anything too small to be reliably identified as a void is ignored, and any spuriously large measurements- indicating errors- would also be ignored.
- Extract these results as a .csv file, showing measurements of all the voids in the target zone.

## Appendix 3: DSC Certificate of Calibration



### Certificate of Calibration

#### Instrument Details

<b>Type:</b>	DSC
<b>Serial Number:</b>	2000-1875
<b>Customer:</b>	NCC
<b>Date of Calibration:</b>	21 NOV 2016
<b>Date Due:</b>	20 NOV 2017

#### Engineer's Comments

DSC serviced and calibrated following TA procedures. All results within specification.

#### Test Equipment

Equipment Used	Type	Certificate number
Indium	156.61 °C ±0.02°C	LGC 2601
Flowmeter	Netech	24032

#### Calibration Values for Temperature and Enthalpy

Before Calibration	After Calibration	Acceptance Criteria
155.69 °C	156.61 °C	± 0.1°C
	28.64 J/g	± 2%
<b>Cell Constant</b>	<b>1.0487</b>	0.9 to 1.3

The above instrument has been inspected, tested and calibrated according to the T A Instruments approved test procedure.

SIGNATURE:



NAME OF ENGINEER: MARK BIRCH

# Appendix 4: DMA Certificate of Calibration 1



**TA**  
Instruments

---

**Certificate of Calibration**

---

Instrument Details	
<b>Type:</b>	DMA Q800
<b>Serial Number:</b>	0800-1478
<b>Customer:</b>	NCC
<b>Date of Calibration:</b>	22 NOV 2016
<b>Date Due:</b>	21 NOV 2017

Engineer's Comments	
All results within specification.	

Calibration Standards			
Standard Used	Type	Certificate number	
	Indium	156.61°C ±0.02°C	
<input checked="" type="checkbox"/>	Polycarbonate	Loss Mod. Peak = 153°C	
		LGC 2601 E1 May 2010	
		N/A	

Calibration Values		
DMA System Calibrations		
Electronics	0.00003	
Force	0.0030	
Dynamic	0.0104	
Temperature Calibration		
Before Calibration	After Calibration	Acceptance Criteria
158.02 °C	153.10 °C	± 1°C

The above instrument has been inspected, tested and calibrated according to the T A Instruments approved test procedure.

SIGNATURE: 

NAME OF ENGINEER: MARK BIRCH



## Appendix 5: DMA Certificate of Calibration 2



### Certificate of Calibration

#### Instrument Details

<i>Type:</i>	<i>DMA Q800</i>
<i>Serial Number:</i>	<i>0800-1478</i>
<i>Customer:</i>	<i>NCC</i>
<i>Date of Calibration:</i>	<i>28 NOV 2017</i>
<i>Date Due:</i>	<i>27 NOV 2018</i>

#### Engineer's Comments

All results within specification.

#### Calibration Standards

Standard Used	Type	Certificate number
Indium	156.61 °C ±0.02°C	LGC 2601 E1 May 2010
<input checked="" type="checkbox"/> Polycarbonate	Loss Mod. Peak = 153°C	N/A

#### Calibration Values

DMA System Calibrations		
Electronics	0.00007	
Force	0.0031	
Dynamic	0.0177	
Temperature Calibration		
Before Calibration	After Calibration	Acceptance Criteria
156.64 °C	153.25°C	± 1°C

The above instrument has been inspected, tested and calibrated according to the T A Instruments approved test procedure.

SIGNATURE:

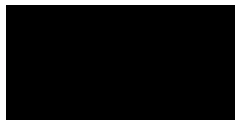

NAME OF ENGINEER: MARK BIRCH

## Appendix 6: Knowledge Transfer Resource Slides

The below presents a suggestion for an industrially targeted knowledge transfer resource, to aid technology in making the leap from academia to industry. This is supplied in the form of a linked PowerPoint document, with two embedded videos. The PowerPoint file- and separate copies of the videos in case of technology incompatibility- can be found on the supplied USB memory stick, along with some of the appendices to this work.

The knowledge transfer resource is for Dielectric Cure Monitoring and includes some of the results presented in Chapter 5, along with relevant examples from the literature [17], [20], [24], [25], [46], [66], [86], [88], [101], [105], background science and practical notes. One of the videos was produced as part of this work, the other, copyright Cranfield university, was produced by Partridge and Smart [227] (EPSRC grant EP/F012489/1).

The structure of the document is based in part on work by Fabris and Poursartip [115], particularly the categorisation into Equipment, Tooling, Part, Material and Process and Producibility. Results presented in Chapter 3 show a clear preference for human-based knowledge transfer. As this is not always practical, the use of videos- structured around people talking about the topic rather than voiceovers showing technology only- is intended to come as close to this as possible. Though it is of course no substitute for a conversation, teaching or mentoring, it is hoped that this can be used to spark discussions or encourage interested viewers to get in touch with those working in the field. Another popular method of knowledge transfer is web search- the interlinked document is intended to mimic web browsing and includes links to external sources.

The knowledge transfer resource focuses on practical, industrial applications for the technology and information that may be useful to a manufacturer of composite parts. As such, the theoretical content is limited, but links to scientific papers allow the interested reader to find out more.

A resource such as this functions best as a living document, being updated as progress is made in technology development, new research is published or in response to the needs of the composites manufacturing community. That which is presented here is a suggestion for a format, which could be applied to other topics and kept updated by a community of practice if it is considered useful.

The reader is encouraged to experience this chapter by exploring the PowerPoint file, which is not linear. As a backup and for ease of reference, small copies of each slide are included here- but please be aware that this printed version does not give the full effect.

# Dielectric Monitoring in Composites Manufacture

Knowledge Transfer Resource  
2018

How it works

Manufacturing use cases

The structure of this document is based in part on the Knowledge in Practice Documents of the Composites Research Network, University of British Columbia. Content is copyright the National Composites Centre (UK) except where stated otherwise. This guide has been produced with reference to the Advise DETA dielectric monitoring system. Other systems are available.

EPSRC
Cranfield UNIVERSITY
Cure monitoring

## Cure Monitoring by on-line dielectric measurement

EPSRC "Collaboration for success through people"  
EP/F012469

Professor I.K. Partridge & Dr P. Smart

Video Copyright © Cranfield University.

# Dielectric Cure Monitoring

Laura Rhian Pickard

Video Copyright © Industrial Doctorate Centre in Composites Manufacture, 2017

## How Dielectric Monitoring Works

Laura's quick intro

- Monitoring the response of the resin to an electric field
- The sensor is a pair of electrodes
- Resin between electrodes is part of the circuit
- During cure, the resin composition changes
- Hence the response of the circuit changes
- This is used to track properties such as  $T_g$ , degree of cure, viscosity and conductivity

Using the sensors

Available systems

More Science

Comparison to other tech

Start

Prof. Partridge & Friends explain

How it works

## Science!

- [Dielectrics basics](#)
- [Sensor technology](#)
- [Why is an alternating current useful?](#)
  - [Equivalent circuit](#)
  - [Why do we use imaginary impedance \(Z''\)?](#)
- [Finding the end of a cure](#)
  - [Using the Z'' peak in the frequency domain](#)
  - [Warning - check you have the right frequency range](#)
- [Tracking material properties](#)
- [Comparison of results to laboratory tests](#)
  - [Hexcel 8552 \(autoclave prepreg\)](#)
  - [Hexion fast curing resin](#)

## Dielectric Cure Monitoring (AC)

- An **alternating current** is applied across the electrodes
- Charged species in the resin move as the electrode charges switch
- The **resin response** is measured at AC frequencies over a set range (e.g. 1 Hz to 100kHz)
- The various charged species in the resin respond differently over the range of frequencies
  - As the resin cures its composition changes, changing the signal
- Resin arrival at the sensor (sharp increase in conductivity) and **end of cure** can be seen
- Material properties- viscosity, degree of cure and  $T_g$  can be **tracked** using the **impedance** over different frequencies and a resin model
- [Compare to a Direct Current system](#)



Scan QR

## Sensor Technology: Disambiguation

Using the sensors

- [Microwave cavity](#):
  - Out of the scope of this document, not suitable for most composite processes. May be useful for pultrusion or microwave cure.
- [Parallel plate electrodes](#):
  - Difficult to use in ovens, autoclaves. Possible in a fixed closed mould where the spacing between the halves is known.
  - Gives a through-thickness measurement for the whole sample
- [Interdigitated electrodes](#):
  - The usual, most flexible option for dielectric cure monitoring
  - Geometry is fixed
  - The electrodes can be very small, allowing small sensors to be made
  - Measurements are taken at the chosen locations only

Science

## Sensor Technology: Microwave Cavity

- Dielectric measurements can also be made using a microwave cavity. This is a different technology, though the same principles are in play, and is outside the scope of this document.
  - Where a metal tool or metal equipment is in use, as is common in composites manufacture, microwave measurements would not be appropriate.
  - May be useful in microwave cure
  - For pultrusion, where a microwave cavity may be built at the end of the die ([see paper](#)) this may be worth investigating.



Academic Paper: Methven & Karamidas 1997

Sensor Tech

## Sensor Technology: Parallel Plate Electrodes

- Sample placed between two large parallel plate electrodes
- Sensor geometry- plate size and separation- must be known for reliable measurement
  - Separation can change with temperature
  - Difficult to use in ovens and autoclaves, possible in closed mould **RTM** only if the spacing between the plates in each mould half is known and fixed.
- Measurements result from the whole sample between the plates, through the thickness
  - Interdigitated electrodes on small sensors only measure at their location



Lambert provide sensors for presses and moulds which use the parallel plate configuration. The opposing mould surface is used as the other electrode.

Sensor Tech

### Sensor Technology: Interdigitated Electrodes

- Each electrode has small fringes, interlocking to give a large electrode surface on a small sensor
  - The resin between the electrode fringes **completes the circuit** allowing us to **track the cure**
- The alternating electric field penetrates a small way into the material
  - Conductive fibres must be **prevented** from shorting the electrode

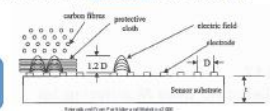

**Using the sensors**

Book Chapter: *Dielectric Properties of Polymers*, Skordos & Partridge, J. Polym. Sci. Part B: Polym. Phys., 2001, 39, 1201-1210

Sensor Tech

### Why is an alternating current useful?

- When a potential difference (voltage) exists across the electrodes on the sensor, the resin becomes polarised
  - positive charges migrate towards the negative electrode and vice versa (**charge migration**)
  - ions accumulate at the resin-electrode boundaries (**electrode polarisation**)
  - dipoles (positive in one region and negative in another, similar to a bar magnet) line up with the electric field (**dipolar relaxation**)
- Each time the current alternates these factors take different amounts of time to respond (**relaxation time**)
  - As the cure progresses and polymer chains grow, relaxation times increase- the polymer chains restrict movement.

**By varying the frequency of current alternation the effects of the different factors can be separated out: the longer the relaxation time, the lower the frequency of the peak signal.**

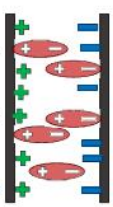

Equivalent circuit

### Equivalent circuit model

- The resin between the two electrodes completes an electrical circuit
- The three factors which determine the response of that circuit can be modelled as a combination of capacitors and resistors
  - Electrode polarisation**, where ions accumulate at each electrode, can be thought of as forming a capacitor with each electrode at the resin edges
  - Migrating charges** form a current between these two capacitors, which encounters a resistance, so is modelled as a resistor
  - Dipole relaxation** occurs in parallel to this, and is further split into two types
    - Induced dipoles** are a response to the electric field. This does not cause a current to flow, so there is no resistor, but does introduce a capacitance.
    - Stick dipoles** move to orient themselves with the electric field so encounter a resistance. Lined up with the field they also introduce a capacitance.

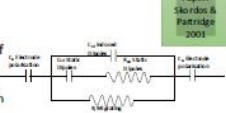

Academic Paper: Skordos & Partridge 2001

Why imaginary impedance?

### Why do we use imaginary impedance (Z'')?

- The **impedance** of an AC circuit is a **complex** quantity
  - $Z = Z' - jZ''$
- The resistors and capacitors of the equivalent circuit affect the real and imaginary components of the impedance differently at different frequencies.
- From the imaginary impedance at different frequencies we can pick out features resulting from electrode polarisation (low frequency), charge migration (medium) and dipolar relaxation (high).
- We can use the peak of the Z'' graph to **track degree of cure**.
- Some systems use **complex permittivity** to investigate resin properties.

*Note for physicists: Here Z' refers to the real component and Z'' to the imaginary component. THEY ARE NOT DERIVATIVES.*

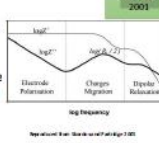

Academic Paper: Skordos & Partridge 2001

Science

### Finding the end of the cure

- Realistically, 100% degree of cure is never quite achieved.
- For a given set of conditions (e.g. temperature and pressure) a point of diminishing returns is reached- where it would take a long time to achieve a miniscule increase in degree of cure.
- At this point we consider the cure to be complete.
  - Post-curing at different conditions may of course increase degree of cure further
- Where a resin model is used with the DEA kit, a simple graph illustrates when degree of cure is no longer increasing noticeably.
- Without a resin model, the end of cure can be estimated from when the conductivity stops changing- **PROVIDED the frequency range is correct for the resin.**
- End of cure can more reliably be estimated to have occurred when the **imaginary impedance peak stops moving.**

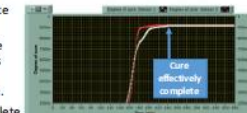

End of cure from Z'' peak

### Use data across frequency range to identify end of cure

- The peak of Z'' **moves to a lower frequency and higher amplitude** as the cure progresses. When it stops moving, the cure has gone as far as it can in these conditions. This is easy to see for isothermal cure.
- There is a correlation between the change in the peak of Z'' and degree of cure (measured by DSC). Degree of cure does not reach 100%, realistically this is never quite achieved.

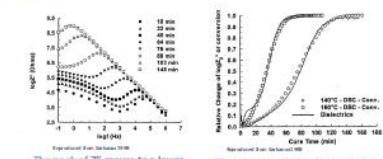

Academic Thesis: Kurhan et al 1998, page 207

Allowing for temperature

### Use data across frequency range to identify end of cure- realistic cure cycles

- For non-isothermal cure, temperature also affects the Z'' peak. But the derivative of the peak can be interpreted in the same way as a DSC trace.
- The derivative of the Z'' peak is used to calculate a conversion (degree of cure), here called IM. (Imaginary Impedance Maximum) It correlates with degree of cure from DSC.

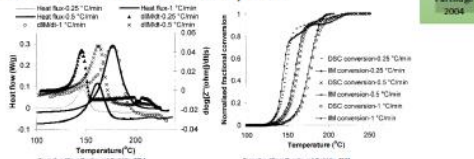

Academic Paper: Skordos & Partridge 2004

NB: Frequency Range

### Potential pitfall- incorrect frequency range

- If the frequency range is incorrect for the resin, it can appear that the cure has finished when in reality the signal has simply gone out of range.



It looks like the cure finished just after 70 minutes...

But did it?

### Potential pitfall- incorrect frequency range

- If the frequency range is incorrect for the resin, it can appear that the cure has finished when in reality the signal has simply gone out of range.

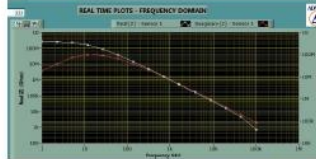

62 minutes. The Z'' peak [red] is at 100MHz and just over 10Hz

What happens to the peak?



### Potential pitfall- incorrect frequency range

- If the frequency range is incorrect for the resin, it can appear that the cure has finished when in reality the signal has simply gone out of range.

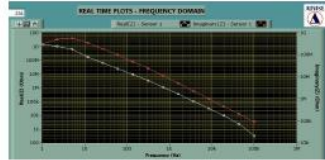

So does it stay in range?

### Potential pitfall- incorrect frequency range

- If the frequency range is incorrect for the resin, it can appear that the cure has finished when in reality the signal has simply gone out of range.

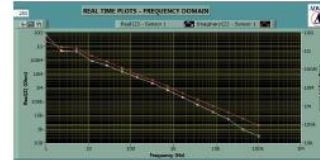

Scan on

### Tracking material properties

- Conductivity can be seen for any resin
  - Resin arrival (flowing as a liquid) is seen as an increase in conductivity
- Z' and Z'' vs frequency can also be seen for any resin
  - The peak of Z'' can be related to degree of cure for example by comparison to DSC measurements
  - A rapid increase in the Z'' peak amplitude can be indicative of gelation.
- To track viscosity, degree of cure or T<sub>g</sub> a material model is needed
  - If this does not exist for your resin, the DEA kit manufacturer can help to develop one



Scan on

### Using the sensors



How it works

### Tool mounted sensors

The sensor must be mounted in a tool and will not cause internal defects, but can only measure the resin on the part surface- use for final parts and for resin arrival sensing.



- Sensor surface should be flush with the tool
- Cables exit from the rear of the tool

- Reusable
- Durable
- No effect on structural properties of the part
- Requires precision machining of sensor cavity in tool
- Surface measurements only
- May mark part surface
- Some housings used for mounting the sensor in the tool have been known to leak
- May affect closure of a mould if not positioned perfectly

Using the sensor

### Flexible sensors

The sensor can be used to take measurements anywhere inside a part, but is cured in place, leaving a defect- use during prototyping and process development or in areas to be removed.

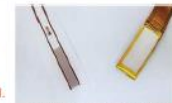

- Cables exit along the surface of the tool
- GIA electrode- cheaper but absorbs resin and becomes dangerously sharp when cured
- Kapton electrode- more expensive, does not absorb resin, comes with integral glass fibre veil
- Place anywhere inside the part
- Glass fibre veil, to prevent shorting the electrodes can be built in
- Single use
- Sensor is cured into the part
- Sensors and connectors are delicate and easily damaged

Using the sensor

### Heater Cell

Laboratory equipment for temperature controlled cure of small samples of resin or prepreg with built in dielectric sensor- use for testing resin behaviour and checking small samples of materials.



- Sensor and thermocouples are in the base of the heater cell
- Ensure the sensor is covered with the resin or prepreg sample
- Clean thoroughly with frekote or similar before and after use
- Temperature controlled heater cell
- Cheaper than curing a full size part in standard manufacturing equipment
- Cell cannot apply pressure or vacuum
  - No consolidation of prepreg
  - Bubbles may form on the sensor
- Small sample testing only

Using the sensor

### Hints and Tips: Vacuum Bagging

Step	Instruction
1	Preparation
2	Vacuum bag
3	Prepreg lay up (see prepreg)
4	Impregnation (see prepreg)
5	Final lay up
6	Vacuum break and seal
7	Vacuum break and seal

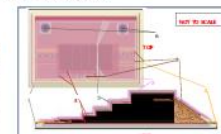

- If sensors or cables need to pass through the seal of a vacuum bag, separate them out at the exit point. Place bagging tape underneath first, press the sensors/cables firmly into the tape then place another layer of bagging tape on top, again pressing down firmly. Connect both layers to the rest of the seal.
- If flexible sensors are left loose or undergo a sharp bend they can snap when vacuum is applied. Support the sensors using cork or similar.

More hints

### Hints and Tips: Sensor and cable placement

- The sensor only gives a measurement at the point where it is placed. Consider where the most important points are for your part. Modelling may help to determine the best placements.
- Flexible sensors, which can be simply placed or stuck on a tool, can be used for test runs rather than machining holes immediately for the fixed, tool mounted sensors.
- The sensor must be completely covered with resin.
- Put a thermocouple to the side of each sensor in order to accurately track the cure progress with temperature. The thermocouple should not touch the sensor or be located directly above or below it (in the electromagnetic field).
- Ensure the cables can reach the data acquisition boxes- if using an oven or autoclave, a pass-through will be required. The software may need to be calibrated for cable length.
- Cables should be shielded to reduce noise and should not be twisted together.

More hints

### Hints and Tips: Other

- Carbon fibre is conductive. When using carbon fibre, the electrode must be covered with a glass fibre veil, to prevent carbon fibres shorting the circuit. Some [flexible sensors](#) have integral veils.
- Ensure any bare wires or solder are insulated from the tool, for example with release tape.
- [Degas](#) your resin. Bubbles over the sensor can affect the result. Resin will seep everywhere.
- If you currently track the process of the cure based on thermocouple measurements and a simulation or model, dielectric sensors can be used to test- and hopefully verify- this model.
- If you only wish to make occasional use of dielectric monitoring technology, or wish to test it out before committing to regular usage, it may be worth outsourcing your tests or hiring equipment.

Using the sensors

### Available systems

*This is solely a list of systems the author is aware of and should not be considered either exhaustive or a recommendation.*

- Advise
- INASCO
- Lambient
- NETZSCH
- Novocontrol

Synthesites Optimold DC cure monitoring system has been referred to as a [comparative technology](#).

How it works

### Comparison to other technologies

- The linked review paper gives a brief overview of a variety of in-process monitoring techniques, comparing them and assessing usability in industry.
- [Comparison of  \$T\_g\$  and Degree of Cure from DEA with DSC and DMA laboratory tests and simulation with Raven software \[Hexcel 8552\]](#)
- [Comparison of Imaginary Impedance peak with DSC for fast curing resin \(Hexion\)](#)
- [Comparison of technology to ultrasonic sensors](#)
- [Comparison of technology to Direct Current cure monitoring with Synthesites Optimold](#)

How it works

Academic Paper: Korka-Latocka et al 2014

### Hexcel 8552: DEA vs DMA, DSC and Raven Simulation

- A [stepped wedge](#) of 8552 prepreg was used as the test part. DEA sensors were placed in the centre of the thin and thick extremes.
- The Advise DETA kit was used, with Advise's material model for 8552, which is based on the [NCAMP model](#).
- 8 wedges were cured over different cure cycles, leading to a variety of final degree of cure and  $T_g$  measurements.
- The same material model is used in the [Raven simulation software](#). Simulations based on the thermocouple data for each cure were used to calculate expected  $T_g$  and degree of cure values for each step of the wedge.
- The DEA final (end of cure) degree of cure and  $T_g$  measurements for each extreme were compared to both the simulation result and laboratory tests of samples taken from the same region as the sensor.
- The majority of the DEA results were within experimental error of the laboratory tests, excepting where  $T_g$  degradation is seen at high degree of cure.

Result vs DSC

Thesis Chapter 5, Pickard 2018

### Hexcel 8552: DEA vs DMA, DSC and Raven Simulation

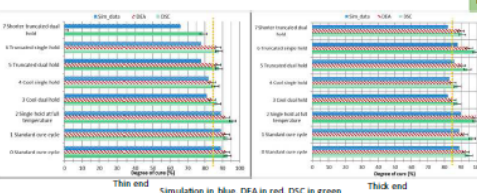

Degree of cure measurements from DEA were compared to DSC tests of samples taken from the same region and Raven simulations based on thermocouple readings. One sensor failed (cure 7 thin end).

Result vs DMA

Thesis Chapter 5, Pickard 2018

### Hexcel 8552: DEA vs DMA, DSC and Raven Simulation

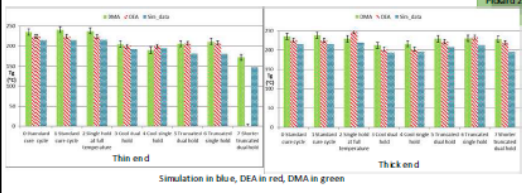

$T_g$  measurements from DEA were compared to DMA tests (tan  $\delta$  peak) of samples taken from the same region and Raven simulations based on thermocouple readings. The model used in the DEA system does not include  $T_g$  degradation at high degree of cure, hence the discrepancy in cure 2 at the thick end. One sensor failed (cure 7 thin end).

DEA v other tech

Thesis Chapter 5, Pickard 2018

### Hexion fast curing resin: $Z''$ peak compared to degree of cure from DSC based model

- The resin is a fast curing (few minutes) epoxy for use in [RTM](#).
- DSC measurements of degree of cure were used to develop a model.
- The Advise DETA system was used to monitor the resin over the same cure profile.

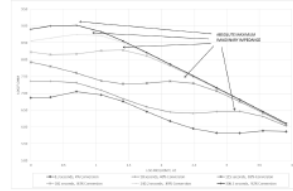

This graph shows  $\log Z''(f)$  vs  $\log$  frequency (Hz) for a selection of timesteps. The peak (here called absolute maximum) is used to track the progress of the cure. This peak can be seen increasing in magnitude and moving to lower frequency as the cure progresses. This is because the increase in crosslinking in the resin makes it harder for the species to move.

Result

Academic Paper: Martin et al 2015

### Hexion fast curing resin: $Z''$ peak compared to degree of cure from DSC based model

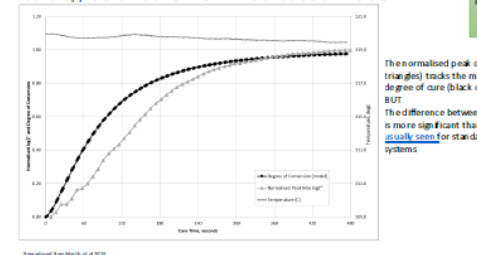

The normalised peak of  $Z''$  (grey triangle) tracks the model for degree of cure (black dots) BUT the difference between the two is more significant than that usually seen for standard epoxy systems

DEA v other tech

Academic Paper: Martin et al 2015

### DEA vs Ultrasonic sensors

- Two ultrasonic sensors (bulk wave and guided wave, separate samples) were compared to degree of cure from DSC and  $Z''$  peak from DEA.
- The amplitude of the reflected peak of the ultrasonic wave and the velocity of sound in the material were considered for tracking the cure.
- The ultrasonic sensors showed promise for tracking the final stages of the cure but could not track throughout.
- The ultrasonic sensors can however be embedded without wires (inductive coupling is used) and used for structural health monitoring in a final part where this is appropriate.
  - Like DEA sensors, ultrasonic sensors left in a production part can be considered defects from a structural perspective so this must be allowed for in the design.
- The DEA sensors functioned throughout the cure and the  $Z''$  peak appears visually to follow the same shape as the DSC results.

See the graphs

Academic Paper: Chiles et al 2016



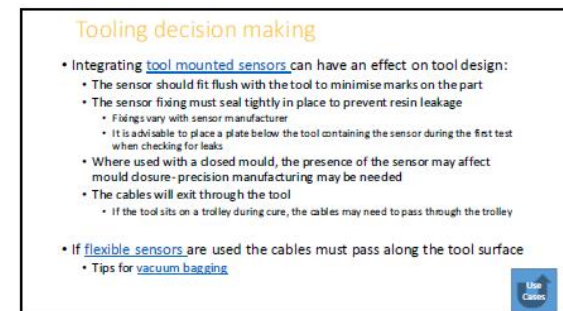
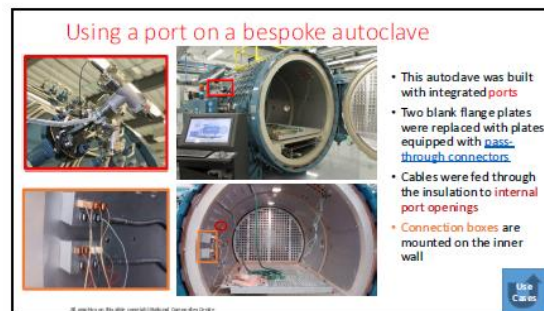
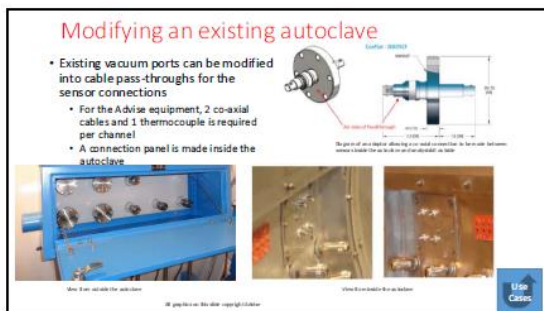
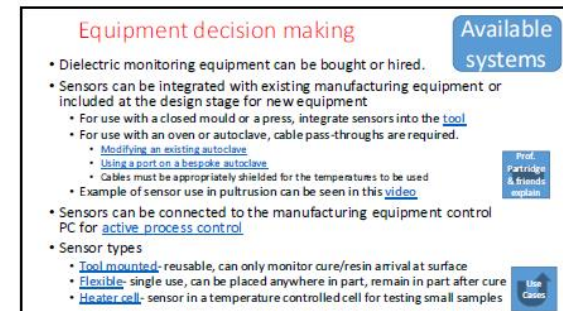
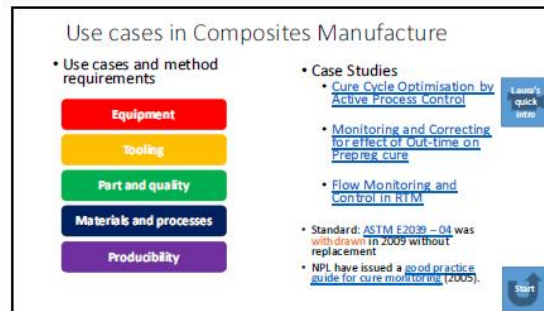
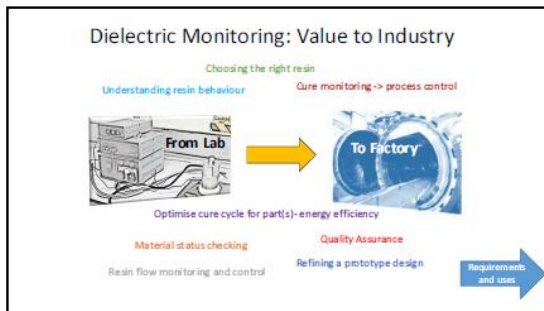
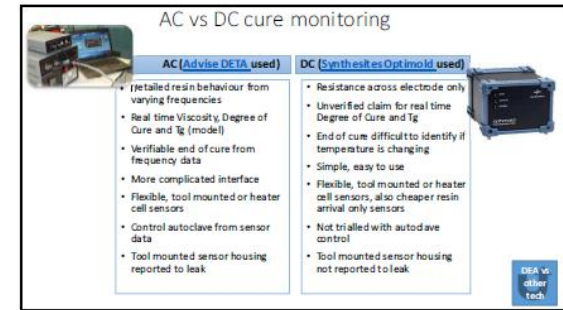
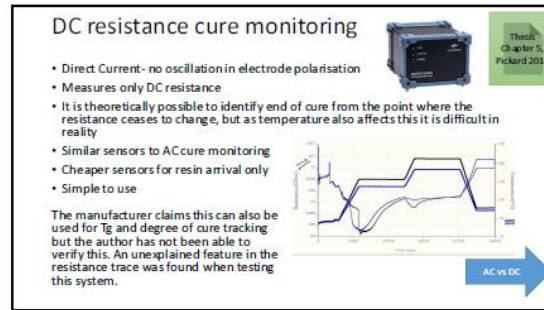
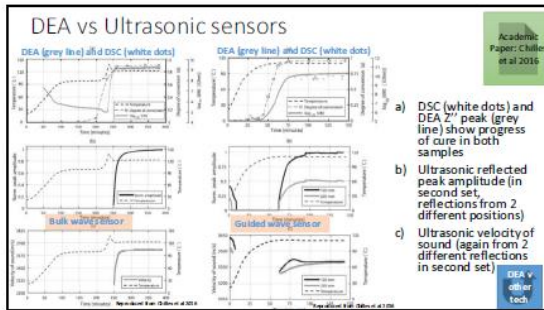

## Part decision making

- Tracking the cure in different regions of the part during prototyping may inform refinements to the design or choice of [materials](#)
- [Flexible sensors](#) can be placed anywhere in the part
  - Measure the cure at any position
  - They remain in place after the cure, as essentially a very large defect running from the monitoring to the exit point
    - Use throughout the part during R&D and prototyping for information on how the cure proceeds in different regions of the part, and/or for model development and verification
    - In production parts, locate sensors in edges or other areas which will be removed after cure, or move to tool mounted sensors
- [Tool mounted sensors](#) contact the part surface
  - Can only track the cure at the surface
  - May leave a mark on the surface
    - Do not place anywhere surface finish is critical unless the mark can be removed with machining



## Part use case: Quality Assurance and Control

- Monitoring and, where appropriate, controlling the process (either [automatic](#) or via human input) for factors such as:
  - Resin:hardener ratio in liquid resin processes
    - If the resin and hardener respond sufficiently differently to the alternating current, the combined signal can be used to monitor the mix
  - [Material status prior to cure](#)
  - [Degree of cure and glass transition temperature of each individual part, during and at the end of cure](#)
- The sensor records may be used to demonstrate whether or not the material used, cure followed and part properties meet the requirements



## Materials and processes use cases

- [Important: if using a conductive reinforcement \(e.g. Carbon Fibre\) the sensor must be shielded with a glass fibre veil](#)
- Cure cycle investigation at prototyping stage
  - Use flexible sensors throughout a part prototype to track the cure in different regions (e.g. different thicknesses of material)
    - Record the evolution of material properties throughout the part during the cure
    - Use to optimise the cure to suit business requirements, e.g. [minimising energy](#) or time taken to achieve the required material properties, or developing a cure cycle which produces good results for a variety of parts so they can all be cured at once
    - Finish the cure cycle when the [effective end of cure](#) is reached, saving energy, time and money
    - Develop and verify a model for the part cure, allowing monitoring of cure (for [quality assurance/control](#)) for production parts with surface based sensors only
- Resin study with the heater cell
  - Using the [heater cell](#) the response of small samples of resin or prepreg to temperature profiles can be studied, providing information for the choice of resin and cure options
    - Where a dielectric monitoring model for the resin has not yet been developed, this can be developed in collaboration with or by outsourcing to the equipment manufacturer



## Producibility use cases

- [Resin arrival monitoring and control](#)
  - Eliminate dry spots in RTM using resin arrival monitoring and adjusting actuated resin vents to control the flow
  - Requires [tool mounted sensors](#) and actuated vents to be built in
  - Simpler DC sensors are suitable for this case
- [Material status checking](#)
  - Out-time, variation between batches, local conditions or mix ratios can vary
  - Ensure the cure used is the optimum for the conditions on the day
  - Potentially possible to extend material lifespan, minimising waste
  - Ensure material is within specification for [quality assurance](#)
- [Monitoring during cure for process control](#)
  - Use active process control to modify the cure in response to the sensor output, such as changing the temperature.



## Cure Cycle Optimisation by Active Process Control



- Autoclaves are commonly used-but need a lot of energy
- Use dielectric monitoring to control the autoclave and automatically end the cure when the required degree of cure is reached
- The result is compared to standard and lower temperature cures
- Energy, CO<sub>2</sub> and money savings estimated for this part
- Advise DETA dielectric monitoring system used



## Cure Cycle Optimisation by Active Process Control



- Variable thickness test part
- Embedded [flexible dielectric \(DEA\) sensors](#)
- This part requires 85% degree of cure
- 852 prepreg
  - Model available for Advise system
  - Commonly used in industry

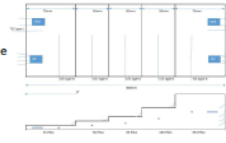

## Cure Cycle Optimisation by Active Process Control



- 852 cure cycles
  - Standard
  - Single 3h hold at 180°C
  - Second hold at 160°C
    - Based on simulation for achieving 85% degree of cure
  - Single 3h hold at 160°C

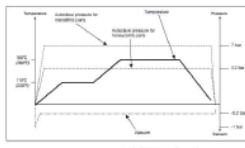

- Dielectric sensor controlled dual and single hold cures, each truncated when both ends of the part reach 85% degree of cure



## Cure Cycle Optimisation by Active Process Control



- Active autoclave control by dielectric sensors
- Sensor signal is processed and material property values (e.g. degree of cure) sent to autoclave
- Autoclave control system monitors these values and can be programmed to trigger a change in the cure cycle based on them
- In this case, when both sensors (thin and thick extremes of the part) read 85% degree of cure or more, the autoclave moves to the end of cure sequence.
- The sensor readings were compared to [laboratory tests](#) of samples from the cured wedges to verify the results.

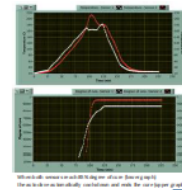

## Cure Cycle Optimisation by Active Process Control



Cure cycle	Time (h)	Temp (°C)	CO <sub>2</sub> (kg)	Energy (kWh)
Standard	3.0	180	37	93
Optimal	1.8	180	20	46
Optimal	1.8	160	21	46
Optimal	1.8	160	21	40
Optimal	1.8	160	21	37
Optimal	1.8	160	21	34

- The sensor controlled 1 hold cure delivers the required properties for a reduction of 70kWh and 37kg of CO<sub>2</sub> equivalent compared to the standard cure cycle
- The difference between this and the standard cure cycle is the equivalent of driving a standard petrol car 100 miles
- [https://www.carbontrust.com/media/18223/st1153\\_conversion\\_factors.pdf](https://www.carbontrust.com/media/18223/st1153_conversion_factors.pdf)

Dielectric sensors can be used for active process control, saving energy and money by ending the cure when the required properties are reached.



### Monitoring and Correcting for effect of Out-time on Prepreg cure

Academic Paper: Kim et al 2014

- Resin in prepreg 'goes off' over time when not in a freezer due to chemical bonds forming at ambient temperature
  - This increases viscosity, making debulking and creating the part shape harder
  - As the resin is already part-cured, it responds differently to the standard cure cycle
- Prepreg manufacturers state a limit on out-time
  - But local conditions vary
  - If the material could be used after a longer out-time there would be less waste
- Use dielectric sensor to measure conductivity of a sample at a set temperature, to determine material state before use
- Adjust cure cycle to compensate
- Advise DETA dielectric monitoring system used

Charges with out-time

Modifying the cure

### Monitoring and Correcting for effect of Out-time on Prepreg cure

Academic Paper: Kim et al 2014

- Measured conductivity of prepreg at 30 degrees
  - Conductivity decreases as out-time increases
- Monitor during cure
  - As out-time increases:
    - Peak conductivity decreases
    - Gel time ( $t_{gel}$ ) decreases

Modifying the cure

### Monitoring and Correcting for effect of Out-time on Prepreg cure

Academic Paper: Kim et al 2014

- Changes in out-time result in changes to the response to the cure
  - Results shown for two cures, A at 93-C and B at 121-C
  - Minimum viscosity (top) and gel time (bottom) shown vs ramp rate and out-time
- Cure cycle can be adjusted to account for this

A conductivity measurement prior to laying up a new part indicates whether or not the material is usable and if so which cure cycle to use.

Use Cases

### Flow Monitoring and Control in RTM

Academic Paper: Devillard et al 2005

- Racetracking in RTM can result in dry patches in the part
  - Common reason for failed parts in liquid resin processes
- Use resin arrival monitoring to identify racetracking and, referring to flow models from simulation, open or close resin vents to change the resin flow and ensure full wet-out
  - Sensors detect flow front
  - Compared to simulation
  - Necessary action identified
  - Vents automatically opened or closed in the mould

Mould design

### Flow Monitoring and Control in RTM

Academic Paper: Devillard et al 2005

- Mould design
  - Inserts used to cause deliberate racetracking
  - Tool mounted resin arrival sensors (DC sensors made by authors)
  - Computer controlled actuated gates on resin vents
    - Open or close to change resin flow within mould

Simulation of flow scenarios

### Flow Monitoring and Control in RTM

Academic Paper: Devillard et al 2005

- Racetracking is not always the same
  - Simulation used to find possible flow scenarios
  - Control action of opening or closing actuated gates to cope with each scenario

Putting it all together

### Flow Monitoring and Control in RTM

Academic Paper: Devillard et al 2005

- Resin enters mould
- Resin arrival detected by sensors
- Flow front matched to simulation
- Control action taken
- No dry spot

Controlling resin flow based on resin arrival sensors can eliminate dry spots.

Use Cases

### Glossary

Back

- Charge Migration
  - Movement of free charges between electrode, forming an electrical current
- DC resistivity
  - Measurement of the response of a substance—usually a polymer resin—to an electrical field applied across that electrode plate in contact with the substrate under test, at a fixed test current only.
- DC Conductivity Analysis (Dielectric Spectroscopy)
  - Measurement of the response of a substance—usually a polymer resin—to an electrical field applied across that electrode plate in contact with the substrate under test.
  - Usually conducted with an alternating current across a range of frequencies.
  - With a model of the substance, material properties can be made to the conductivity of the substance.
- Debulk
  - Use of a vacuum system to remove air from a part made of prepreg, compressing the tack of prepreg layers.
- Degain
  - Use of a vacuum system to remove air or other gases from liquid resin.
- Degree of cure
  - The fraction or percentage of the maximum possible amount of chemical bonds formed between polymers in the resin. DSC is not a suitable or precise.
  - Orientation of individual wall studs (stick) parallel to align with the axial electric field.
- DSC (Differential Scanning Calorimetry)
  - A thermal analysis technique where the heat flow measured to heat a sample of resin is compared to that of an alternate electrical energy control.
  - To authenticate the cure, the heat needed during cure is compared to that of the sample under test.
- DMA (Dynamic Mechanical Analysis)
  - A sample is subjected to a sinusoidal oscillation over a range of temperatures, while the applied stress, strain response and phase lag(s) are measured.
  - $T_g$  is defined as the position of the peak in the response.
- Electrode polarization
  - Accumulation of ions on an electrode surface.

### Glossary

Back

- Induced dielectric
  - A normally non-polar item become polarized by an electric field, with the area closest to the positive electrode becoming negatively polarized and vice versa, as electrons within the item are attracted toward the positive electrode.
- Out-gas
  - The amount of time a material, usually a roll of prepreg, has spent outside a freezer.
- Prepreg
  - Non-thermoset or cured resin with reinforcement impregnated with resin, a sticky, semi-flexible material. Usually kept in a freezer when not in use to minimize formation of bonds in resin at ambient temperature.
- Resin wetting
  - Depth and flow of resin into a gap between prepreg and mould in liquid resin process. Can cause dry spots in other areas of the mould.
- Relaxation time
  - The amount of time it takes for a response to a change or perturbation to reach a new equilibrium state.
- RTM (Resin Transfer Moulding)
  - Liquid resin is injected into a closed mould containing a fibre reinforcement preform to create a composite part.
- Static dielectric
  - An item which permanently is a positively charged region and a negatively charged region.
- $T_g$  (Glass Transition Temperature)
  - The temperature at which a polymer changes from a hard, glassy substance to flexible and rubbery.
- $Z''$  (Z'')
  - Impedance (Z'') is a measure of the opposition a circuit presents to a current when an AC signal is applied, used in AC circuits comparable to resistance in a DC circuit. It is a complex quantity, Z' is the real component, Z'' is the imaginary component.

## Appendix 7: Knowledge in Practice Document for Dielectric (and DC) Cure and Resin Arrival Monitoring And Control Using Electrode Based Sensors

The following document was created by the author during secondment to the Composites Research Network, University of British Columbia, Canada, based on their structure and requirements for a Knowledge in Practice Document [115].

It is reproduced as originally written, with references included within the text. Not every topic heading has content, as case studies and relevant information are not available in all areas.

KPD for Dielectric (and DC) Cure and Resin arrival monitoring and control using electrode based sensors.

Laura Rhian Pickard, April 2016.

National Composites Centre and University of Bristol, UK.

1. Knowledge
  - a. Foundational
    - i. Scientific principles

## Scientific Principles

### Summary

A dielectric sensor can be used to follow the progress of a cure or identify wet-out of a mould, and to study the behaviour of a resin.

The sensor contains two charged electrodes, whose charge is switched repeatedly. When the resin comes into contact with the sensor, the particles which make up the resin move according to this charge, giving a signal which can be measured, as illustrated in figure 1. As the cure progresses, these movements change and eventually stop. The signal can be correlated with degree of cure. An example application is shown in figure 2.

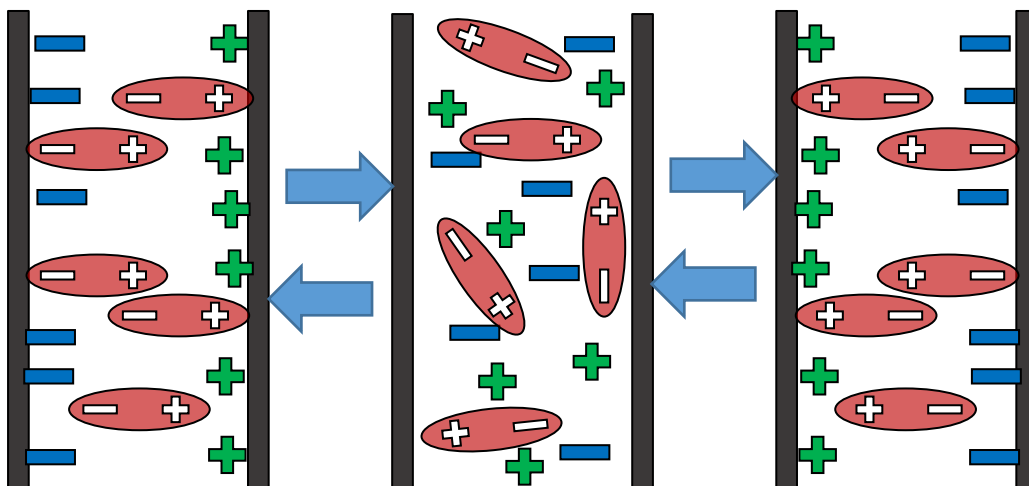
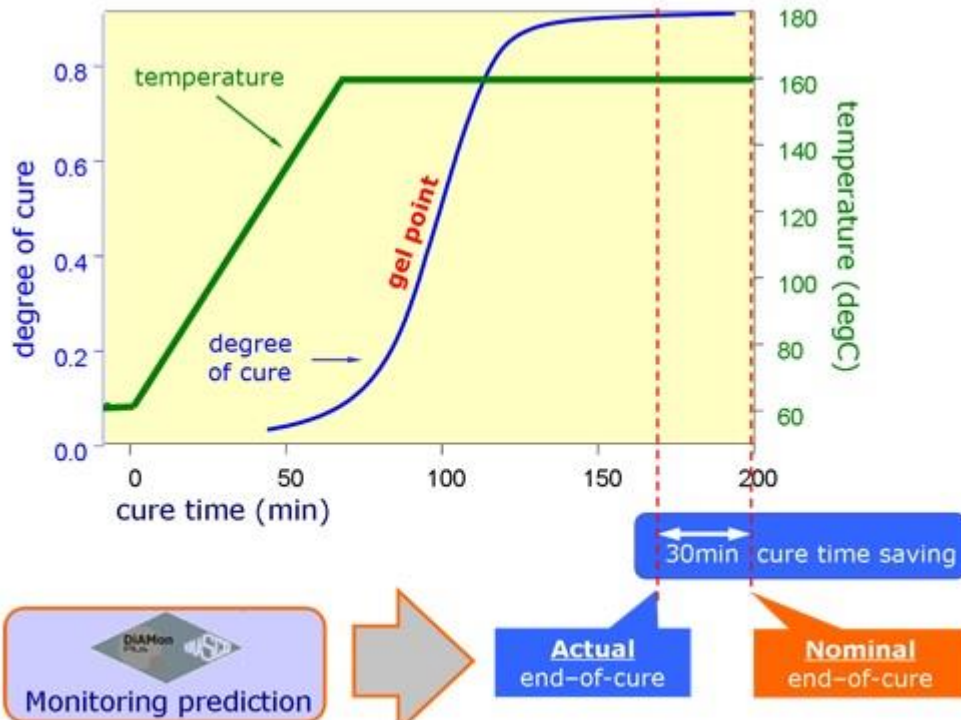

Figure 1: Switching the charge on the electrodes causes the particles to move.





The cure cycle savings amount up to 30% of the total time (including the cooling stage), which results to significant energy savings and increased utilisation of the manufacturing tools.

Figure 2: Reproduced from INASCO. An example of how dielectric sensing can be used to reduce cure times.

DC sensors have a similar setup but do not alternate the current, and hence can only measure the resistance caused by ion movement (ion viscosity).

**Resin response during cure**

The potential difference between the electrodes is switched by an alternating current. Different particles within the resin move at different rates- hence they respond to different frequencies in the alternating current. As the cure progresses, these responses change. A variety of datasets can be plotted including conductivity, resistivity, ion viscosity/DC resistivity, permittivity or impedance of the resin, all of which show slightly different things. DC sensors can record only DC resistivity, also known as ion viscosity.

If the resin is characterised and the system set up accordingly, viscosity, gelation temperature ( $T_g$ ) and degree of cure can be directly plotted. While resin viscosity becomes infinite upon gelation, ion viscosity does not as the charged particles (and dipoles, if you are measuring impedance or permittivity) continue to respond to the electromagnetic field.

When cure is completed, the signal flattens and no further change is seen \*.

Check with the manufacturer to ensure the equipment has the right frequency range for your resin or there may be confusion on detecting the end of the cure.

Figure 3 shows an example using ion viscosity, with key features marked.



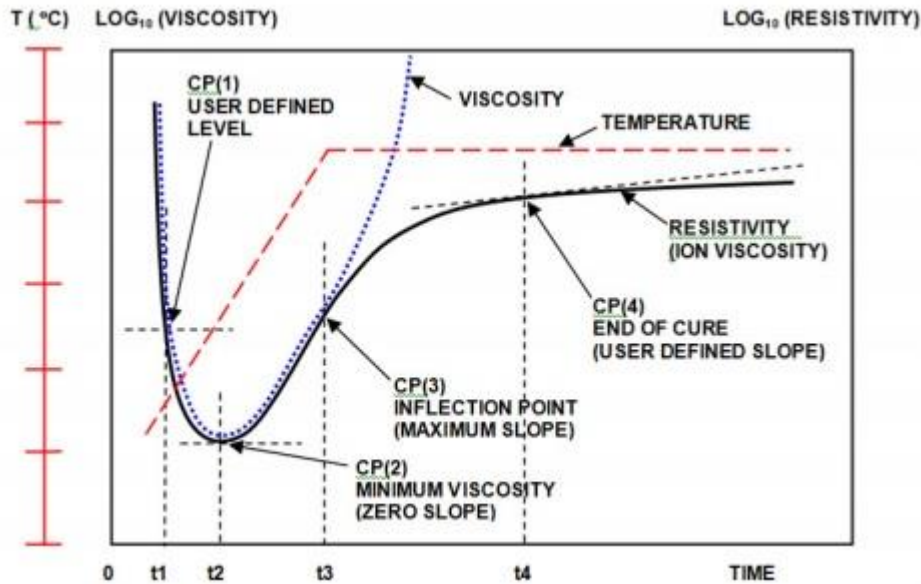

Figure 3. Example data with critical points marked, reproduced from Lambient. CP(3) is considered an indication of gelation as this is when the resistivity (or conductivity) undergoes the maximum rate of change, and hence is the point where the mobility of the ions decreases most sharply.

The flattening of the signal at the end is considered the end of the cure.

In most cases, when the signal becomes flat and no further change is seen, the cure is completed- UNLESS the signal has gone beyond the range of the detection system. Where graphs of the detailed data are available, you can check this.\*

### **\*WARNING – CHECKING THE END OF CURE**

Be wary of concluding a part is cured without checking all the data- particularly when using a new resin- as the signal may have moved out of the frequency range of the equipment.

To check this, and to find other features, you can look at the individual graphs for Z'' versus current frequency, and step through the timesteps. The peak will stop moving when the system is cured. If it moves out of range rather than stopping, then you have gone beyond the range of the system. The change in the peak of Z'' with cure progress is shown in figure 4 and 5. An example of a system where the peak moves out of range is shown in figure 6. This can be done with dielectric sensors, but not with DC sensors.

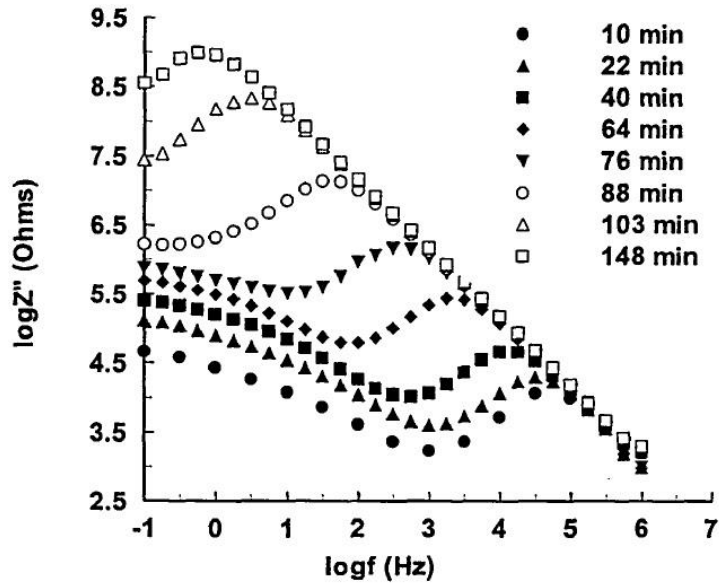

Figure 4: Reproduced from Karkanas 1998. The peak of  $Z''$  moves to a higher frequency as the cure progresses. 140 degree Celsius cure of RTM 6.

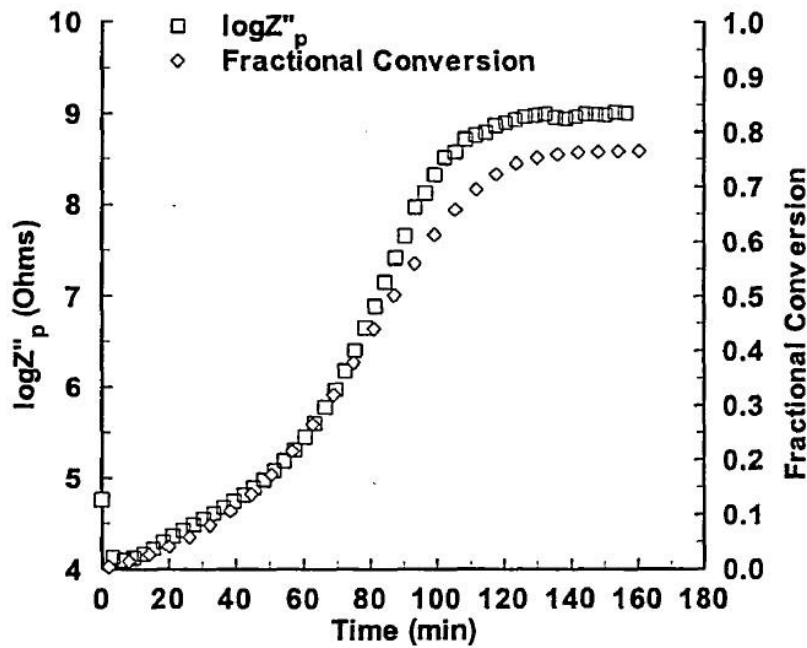
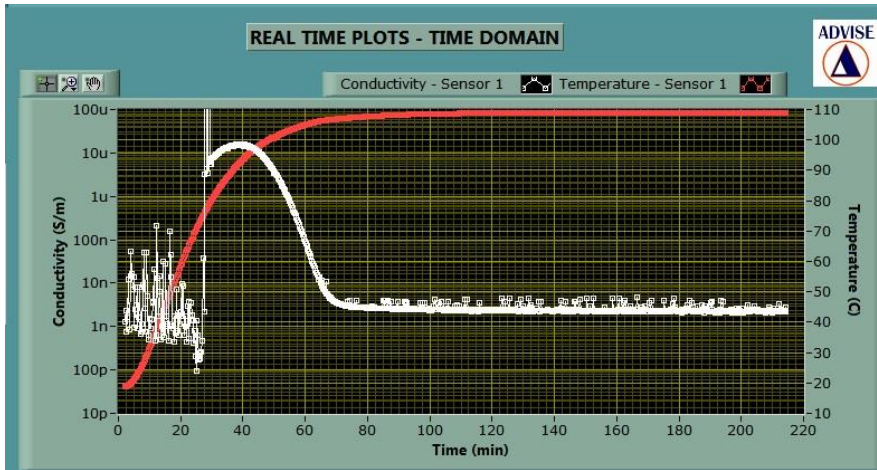
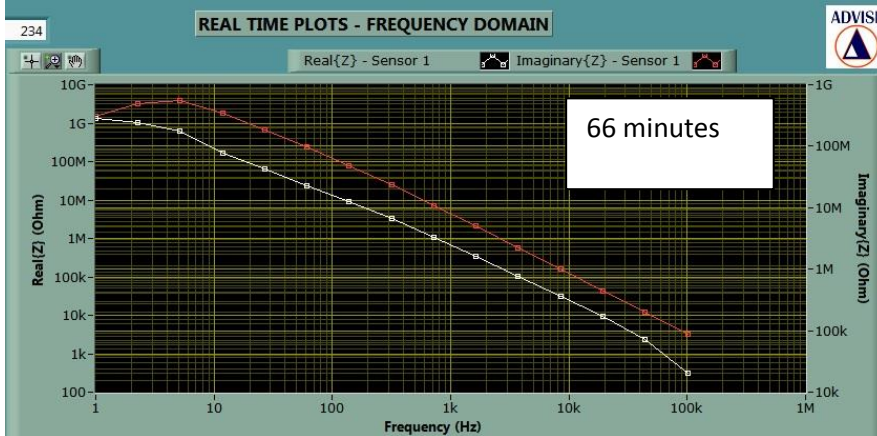
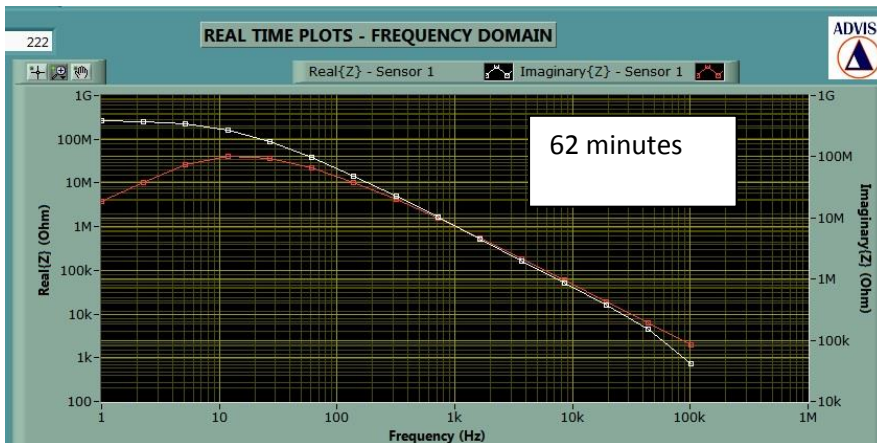
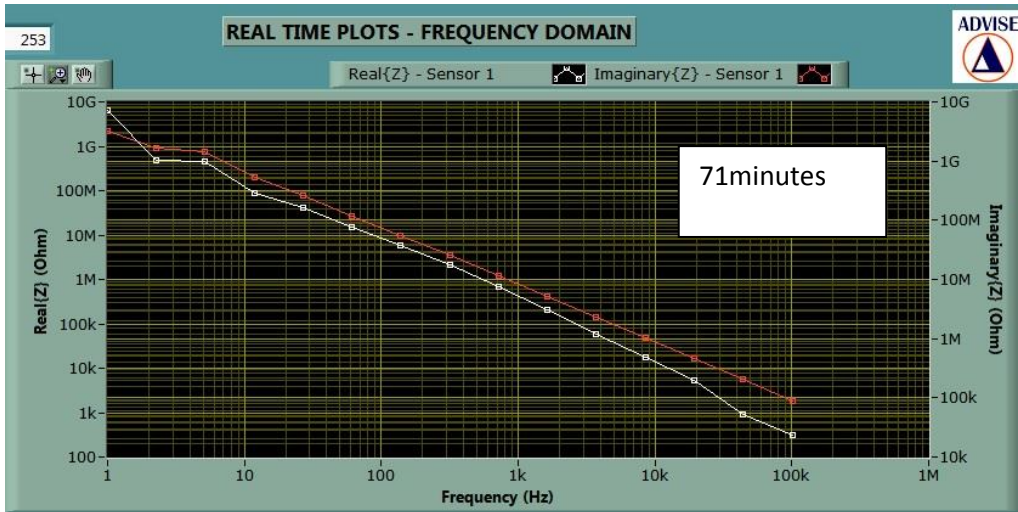

Figure 5: Reproduced from Karkanas 1998. There is a correlation between the peak of  $Z''$  and degree of cure. As the cure completes, the peak stops moving. 140 degree Celsius cure of RTM 6.



(a) Plot of conductivity and temperature versus time. The signal is noisy until the resin flows onto the sensor. Then conductivity increases with temperature until the cure begins. It appears that the cure ends at 80 minutes, but this is not the case. Note that conductivity is  $1/\text{resistivity}$ .





(b) Plots of  $Z'$  and  $Z''$  at timesteps during the cure. The peak of  $Z''$  moves beyond the equipment range, so we cannot be sure when the cure has actually completed. Compare to figure 8 for more information.

Figure 6: The conductivity graph (a) makes it appear as though the cure has completed, but the  $Z''$  graphs (b) show otherwise. Advise flexible sensors were used with a glass fibre prepreg in an oven.

### Why is $Z''$ used?

Measuring the output of a dielectric sensor in terms of the impedance,  $Z$ , allows the system to be considered analogous to an electrical circuit, with the various factors contributing to the overall signal modelled as elements within the circuit. This is referred to as 'equivalent circuit analysis' as shown in figure 7. This means electrode polarisation can be accounted for, and the different responses of migrating ions and dipoles can be separated out.

So the signal measured is given as an impedance ( $Z''$ , imaginary impedance), permittivity ( $\epsilon$ ), capacitance or resistance.

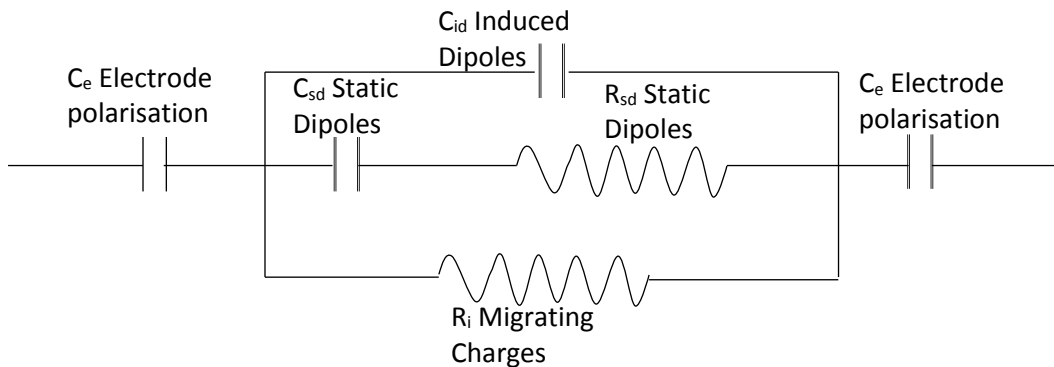

Figure 7. The 'equivalent circuit' used to model the interactions which contribute to the signal from the dielectric sensor. Based on Belluchi et al 1994 and Skordos and Partridge 2001.

Measurements of  $Z$  and/or  $\epsilon$ , split into their real and imaginary components, can show the effects of electrode polarisation, charge migration and dipolar relaxation separately. This is shown in figure 8.

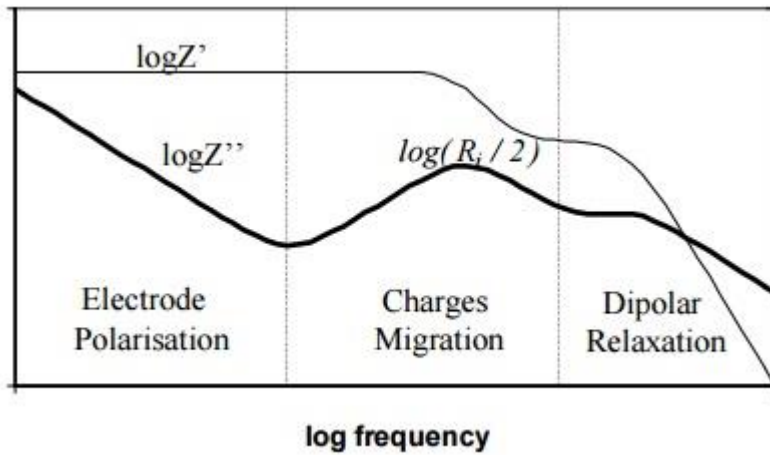
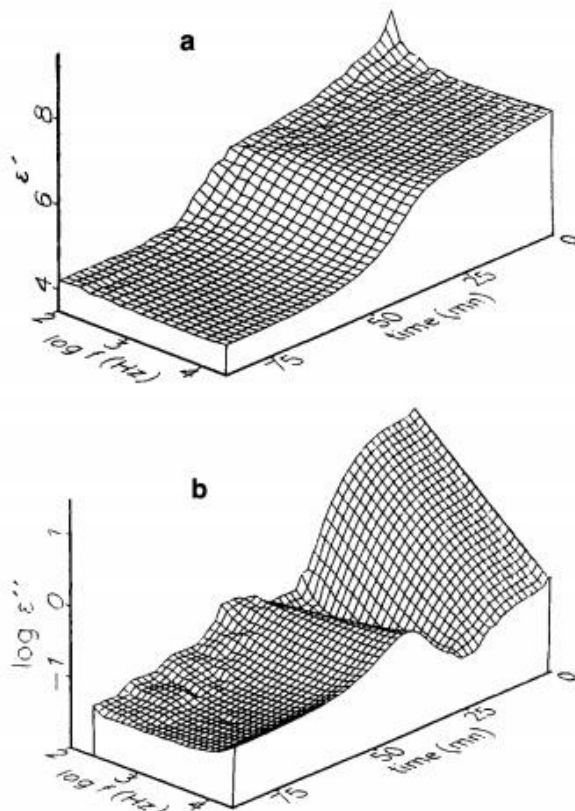
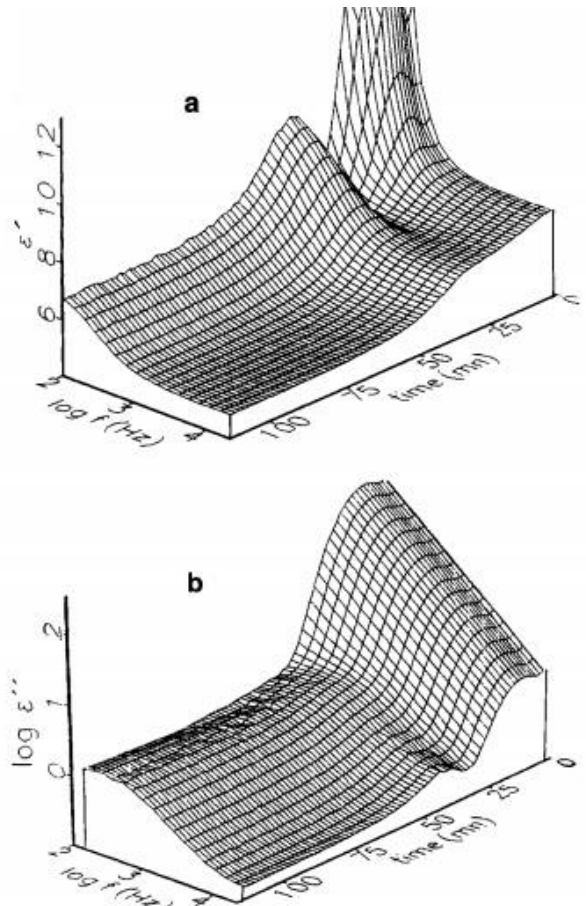

Figure 8: Reproduced from Skordos and Partridge 2001, representation of different components of impedance measurements.

This can show up features of the cure. For example, the graphs in figure 9 compare an epoxy-resin-hardener system, cured at 80 degrees Celsius, against the same system with the addition of 15% CTBN rubber, also cured at 80 degrees Celsius. The extra peak in the  $\epsilon'$  graph for the system with the rubber is an indicator of phase separation. This is from Maistros et al 1992, for more information read the paper.



**Figure 3** Dielectric data on the neat epoxy resin-hardener system cured at 80°C. Plots of: (a) relative permittivity  $\epsilon'$ , and (b) dielectric loss  $\epsilon''$ , against frequency  $f$  and cure time  $t$



**Figure 4** Dielectric data on the blend of epoxy resin and hardener with 15 wt% CTBN rubber, cured at 80°C. Plots of: (a) relative permittivity  $\epsilon'$ , and (b) dielectric loss  $\epsilon''$ , against frequency and cure time. Sample contains highest concentration of adventitious mobile ions (see Figure 5). Note that scales for  $\epsilon'$  and  $\epsilon''$  are different from Figure 3

Figure 9: Reproduced from Maistros et al 1992. The set of graphs on the right show the system with added rubber. The extra peak in the top graph indicates phase separation in the resin.

## ii. Typical system description

### Typical system description

#### Summary

Permanent sensors can be mounted in a tool or mould, or used with a small resin cell for material characterisation. Tool mounted sensors are a practical solution for tracking a production process as they can be reused and do not remain in the part.

Flexible sensors are disposable and can be used throughout the part, remaining in place after the cure- these can be useful to monitor the cure throughout the thickness of the part and are of particular value during prototyping, when designing your cure cycle.

The sensors are connected to a signal processing box, and a connection runs from there to a computer. The interface and control system differs between vendors.



## Disambiguation

Dielectric measurements can also be made using a microwave cavity. This is a different technology, though the same principles are in play, and is outside the scope of this document. Where a metal tool or metal equipment is in use, as is common in composites manufacture, microwave measurements would not be appropriate. However, if microwave cure is being used, or pultrusion (where a cavity can be built on the end of the die, as in Methven and Katramados 1997) this may be worth investigating.

Most of the sensors referred to in this document are the interdigitated variety, where the electrodes are fixed on the sensor surface. Parallel plates with a sample between them can also be used, but as their separation can change with temperature and other local conditions, and the sensor geometry needs to be known in order to measure the various material properties, these are less suited to industrial use.

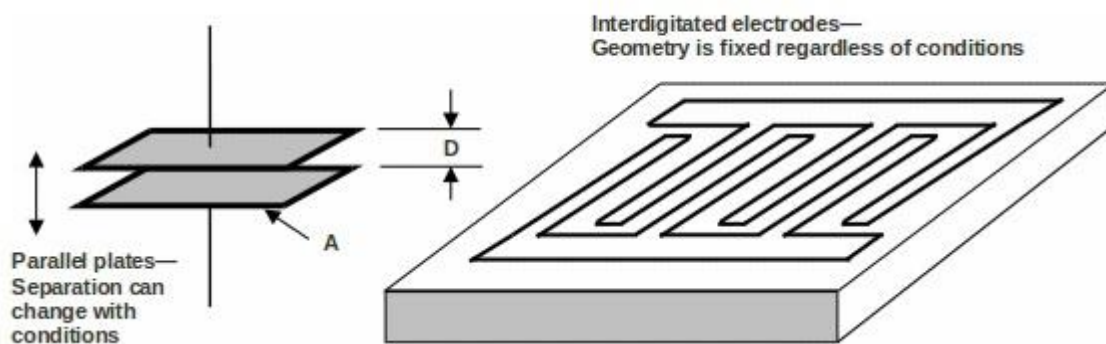

Figure: Parallel plate and interdigitated sensors, reproduced from Lambient theory guide.

Lambient do provide sensors for presses and moulds which use the parallel plate configuration, and these would give a through-thickness measurement rather than just a certain depth from the sensor.



Single electrode sensors from Lambient. The opposing mould surface is used as the other electrode.

## Points to note:

- Carbon fibre is conductive. If you are using carbon fibre, the sensor must be covered with chopped mat glass fibre or a similar material, to provide an insulating layer, otherwise the carbon fibres will short the circuit.
- Ensure any bare wires or solder are insulated from the tool, for example with release tape.
- Degas your resin. Bubbles over the sensor can affect the result.
- The sensor only gives a measurement at the point where it is placed- or in the line where it is placed for the Lambient parallel plate sensors. Consider where the most important points are for your part. The sensor must be completely covered with resin.
- Put a thermocouple to the side of each sensor in order to accurately track the cure progress with temperature. The thermocouple should not touch the sensor or be located directly above or below it (in the electromagnetic field).
- If you currently track the process of the cure based on thermocouple measurements and a simulation or model, dielectric sensors can be used to test- and hopefully verify- this model.
- Ensure the cables can reach the data acquisition boxes- if using an oven or autoclave, a pass-through will be required.
- Cables should be shielded to reduce noise and should not be twisted together.
- If you only wish to make occasional use of dielectric monitoring technology, or wish to test it out before committing to regular usage, it may be worth outsourcing your tests or hiring equipment.

### **Sensor placement**

Sensor placement will depend on the application. The sensor must be in a position to be completely covered with resin. Modelling can help to determine the best placements.

If you are working with trial and error rather than using modelling, it may be worth doing some test runs with the flexible sensors, which can be simply placed or stuck on a tool, rather than machining holes immediately for the fixed, tool mounted sensors.

Resin arrival/flow front monitoring.

For monitoring resin arrival in a liquid moulding process, the sensors should be placed where they will give the most useful information. Modelling of the process can inform the best places to put the sensors, as demonstrated in a case study.

For example, sensors can be placed in potential trouble spots where racetracking might occur, to see if the flow front arrives there before a comparison sensor elsewhere in the tool.

If insufficient resin or insufficient mould pressure leave a predictable dry spot, a sensor can be placed there to alert the operator to the problem and allow them to correct it.

Resin viscosity monitoring.

The response of the resin to the alternating current changes with viscosity. Dielectric sensors can therefore be used to monitor the viscosity of resin in a line or pot, for processes such as pultrusion. There is an ongoing EU project involving this which is due to report at the end of October 2016 (PUL-AERO).



Cure monitoring.

For cure monitoring, it is recommended that sensors be placed in contact with areas of different thickness within the part and areas containing inserts, so that any difference between the thicker and thinner parts (or complicating factors such as sandwich layers) can be seen.

For interdigitated types of dielectric sensor, the signal will only track the cure near the sensor's location, to a very limited depth which depends on the sensor being used. Composites World quotes a typical figure as 125 microns. See Figure for details. Where carbon fibre is being used, the glass fibre layer must cover this depth. Other sensors are used in research (parallel plate sensors) but these are less practical for industrial usage and cannot give as much information.

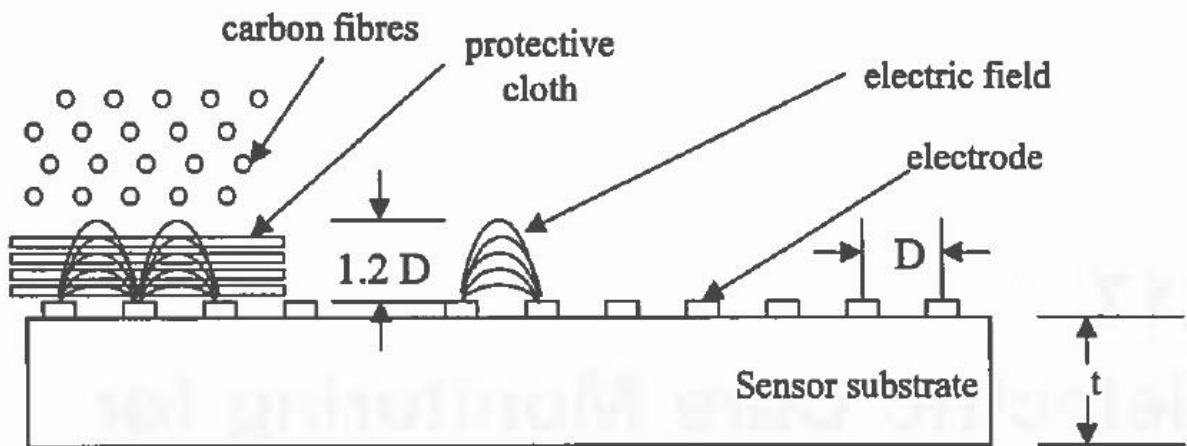

Figure Diagram showing depth of electromagnetic field penetration, reproduced from Partridge and Maistros 2001.

For measurements throughout a thick part, flexible sensors which remain in the part are likely to be required. If this is not acceptable in a production part, the sensors should be located in areas which will be cut off or used only during the prototyping stage.

### Alternative technologies

A combination of a robust model and temperature data can give a good indication of cure progress throughout a part. This requires the resin to be characterised. If a model is to be relied upon, direct measurement of the cure during the prototyping stage is a good way to verify its accuracy and ensure it provides a reliable representation of reality.

Direct Current (DC) cure monitoring has a similar setup, but instead of using an alternating current, a direct current is used. This can measure only the resistance of the resin, but this can still be used to trace the cure progress. In general, dielectric cure monitoring can give more information about the state of the resin and the underlying chemistry- for example, identifying phase separation or hardener activation. The manufacturer claims DC sensing is cheaper and that shielding is not necessary when using a carbon fibre reinforcement as the measurement occurs at the surface only. Tool mounted DC sensors give a surface measurement only and in some cases (not all) cannot penetrate release layers to measure the state of the resin. The sensors themselves are broadly similar to dielectric sensors, with flexible and tool mounted options along with single wire sensors

for measuring resin flow (not cure) only. Where only resin arrival is required, DC sensors designed for flow only are a cost effective option.

Ultrasonic sensors can also be used to follow the progress of a cure. The two technologies were compared by Shepard et al at 1999, and the measurements were found to have a good correlation, suggesting both methods to be viable. There are advantages and disadvantages to both and the best method will depend on the part and the manufacturing process being used. For a detailed comparison, read the paper.

### **The three setups**

Tool mounted sensor.

The sensor is a sealed unit, with cables which must be connected to the data acquisition boxes. A picture of a sensor is shown here. The hole for the sensor and housing must be machined precisely to prevent resin leakage, and the sensor placed flush with the tool surface. Different vendors have different sensor housings and some are easier to fit without leaks than others.



A sensor which can be mounted in a tool, from Advise

If this is to be placed in a closed mould, it is important to ensure the mould will still close with the sensor and housing in place.

When testing a new tool and sensor housing, assume that leaks are possible and take appropriate precautions.



An integrated sensor from INASCO

Flexible sensor.

The sensor can be placed anywhere in the part. It can be delicate, so care must be taken not to scratch the sensor or to detach it from the cables. For some vendors' equipment, it is necessary to solder a sensor to the cable before each use. After attaching a sensor to the cable, and before placing it in the part, test the sensor by plugging the cable into the data acquisition box and inspecting the signal. If it is overly noisy, or no signal can be found, the sensor or soldering may be defective.



A flexible sensor from NETSZSCH

Place the sensor carefully in the part during layup and secure in place with tape. If using vacuum bagging, be careful to ensure there is no air leak around the cable where it passes through the tacky tape.

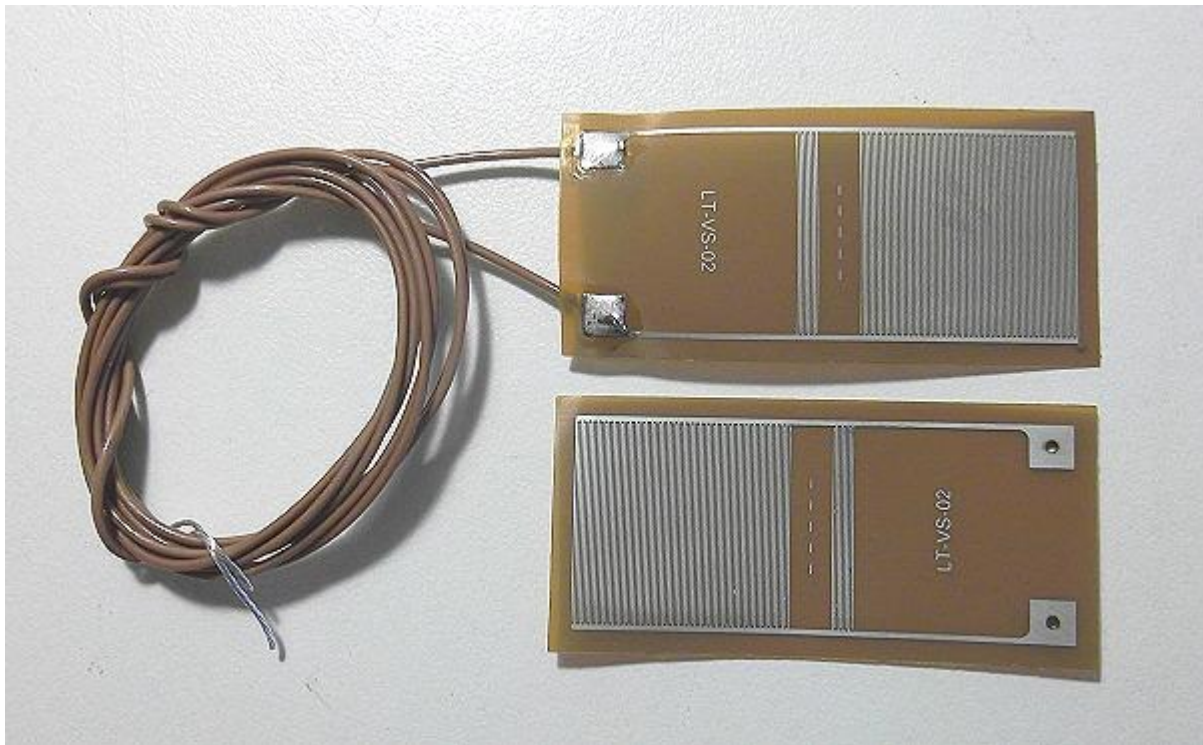

Flexible sensors from Lambient.

After cure, the sensor must be detached from the cable, remaining in the part. This may mean simply cutting the cable.

Resin cell.

The resin cell is used to study and characterise the behaviour of a small sample of resin or prepreg. Very little material is required, just enough to cover the sensor.

The cell contains a sensor and one or two thermocouples. A picture of the Advise resin cell setup is shown here.

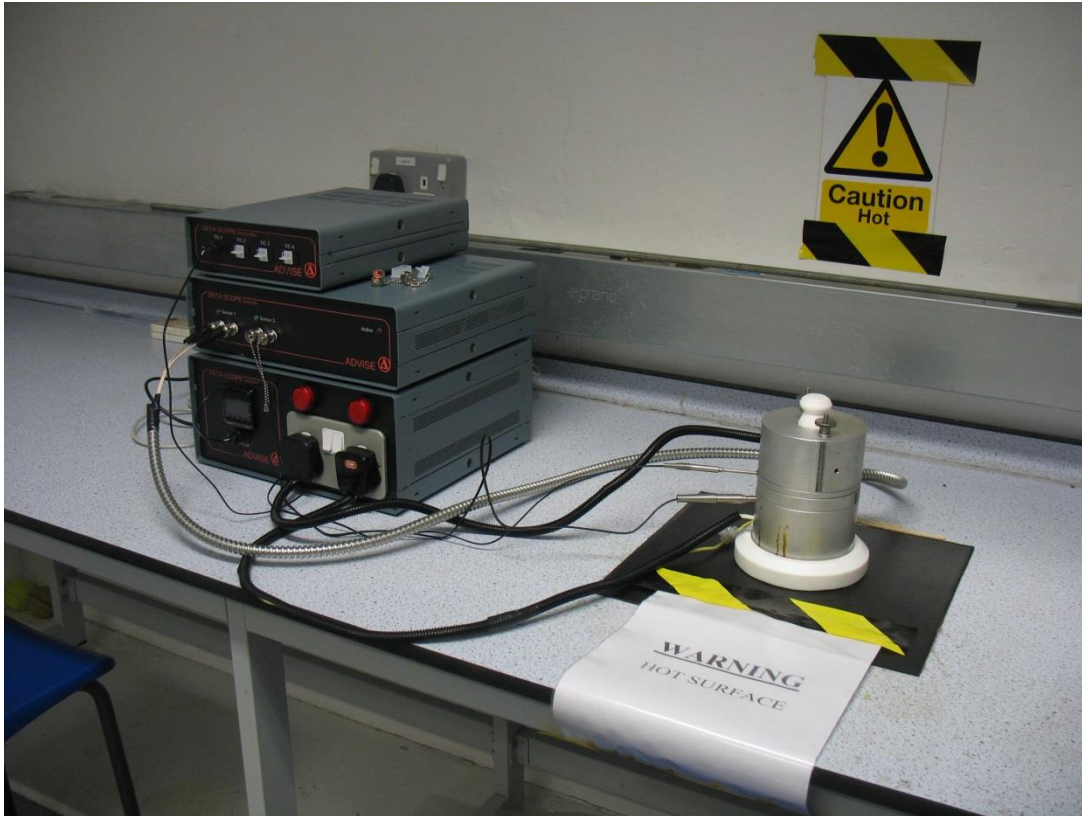

The computer is connected to the processing boxes. The cell temperature is controlled through these, and data from the thermocouple(s) and dielectric sensors are collected. The cell must be coated with a release agent such as frekote before use, and thoroughly cleaned afterwards. The o-rings which sit between the heater blocks and sample holder will require regular replacement.

The resin cell can be used with liquid resin, prepreg or resin film- though the latter is difficult to degas unless heated until fluid, and hence can be messier. It is important to degas the resin as a bubble over the sensor may affect the result. Some resins can 'climb' the walls of the cell, so be prepared for mess.

If the resin cell is used with prepreg, it can be useful to press the prepreg down using a release film covered block, to prevent warping away from the sensor during cure.

### iii. Evolution and History

#### 1. Technology Maturity Level

Dielectric sensors have been in use in research for many decades, but are not yet widely known in industry, though a few trailblazers are now using them in factories. A number of vendors now offer off the shelf dielectric sensing kits, and some will tailor the technology to your requirements.

The interfaces available range from the very simple, designed for ease of use (e.g. green light when resin reaches the sensor) to fully featured software allowing detailed inspection of the data. This varies with manufacturer.

#### b. Industrial Availability (if applicable)

##### i. Typical vendors, configurations, capabilities



Dielectric sensing system vendors include Advise, Lambient, INASCO and NETSZSCH. DC sensor systems are sold by Synthesites.

1. Evaluation
  - a. Technical Maturity Level
  - b. Market Penetration
  - c. Typical Costs – Capital and Operating
  - d. Pros and cons
- c. Comparison to similar and competing methods
  - i. Scientific principles
  - ii. Industrial implementation and availability
- d. Current and Future Trends
  - i. Science
  - ii. Equipment and Development
  - iii. Competitive offerings

### References for section 1

General reading

Mason, K., <http://www.compositesworld.com/articles/monitoring-the-cure-itself> 2006, Composites World

The PUL-AERO pultrusion project <http://www.pul-aero.eu/project/>

Lambient (dielectric sensing system manufacturer) has a more detailed explanation of the theory <http://www.lambient.com/theory.htm>

And a cure monitoring handbook

<http://www.lambient.com/docs/DielectricAnalysisCureMonitoringHandbook.pdf>

NETSZSCH (another manufacturer) also has an explanation of the theory <https://www.netzsch-thermal-academy.com/en/advanced-materials-testing/methods/dielectric-analysis/>

Advise dielectric sensing systems website <http://www.advise-deta.com/>

Synthesites DC cure monitoring <http://www.synthesites.com/page.php?p=22>

INASCO dielectric sensing systems

[http://www.inasco.com/index.php?option=com\\_content&task=blogcategory&id=38&Itemid=96](http://www.inasco.com/index.php?option=com_content&task=blogcategory&id=38&Itemid=96)

Book chapter

Partridge, I.K. and Maistros, G.M., 'Dielectric Cure Monitoring for Process Control', Chapter 17, Vol. 5, Encyclopaedia of Composite Materials (2001), Elsevier Science, London, page 413

Academic papers and theses

Bellucci, F., Valentino, M., Monetta, T., Nicodemo, L., Kenny, J., Nicolais, L. and Mijovic, J. (1994), Impedance spectroscopy of reactive polymers. 1. J. Polym. Sci. B Polym. Phys., 32: 2519–2527.

Shepard, D.D., Smith, K.R. and Thibodeau, L.H., A Comparison of Dielectric and Ultrasonic Cure Monitoring of Advanced Composites, International Conference on Automated Composites 1999, 125-132.

Methven, J.M. and Katramados, Y., In-Line Quality Monitoring of Pultruded Profiles using Dielectric Measurements, *Polymers & Polymer Composites*, Vol 5, No1, 1997

Maistros, G.M., Block, H., Bucknall, C.B and Partridge, I.K., Dielectric monitoring of phase separation during cure of blends of epoxy resin with carboxyl-terminated poly(butadiene-co-acrylonitrile), *Polymer*, Volume 33, Issue 21, 1992, Pages 4470-4478

Skordos, A.A. and Partridge, I.K., IMPEDANCE CURE AND FLOW MONITORING IN THE PROCESSING OF ADVANCED COMPOSITES International Conference for Manufacturing of Advanced Composites, September 27-28, 2001

Karkanias, P., Doctoral Thesis, Cure Modelling and Monitoring of Epoxy/Amine Resin Systems, Cranfield University, 1998.

Any non-attributed diagrams or graphs are provided by the author, L R Pickard.

## 2. Practice

### a. Application from EPTM perspective

#### i. Use in and effect on Equipment Decision Making

##### 1. Summary of Value Proposition

**If you have chosen to use dielectric (or DC) sensors then consider the following:**

Thermocouples must be mounted near the dielectric sensor if temperature measurement is required.

Where an autoclave or oven is used, pass-throughs will be needed. The cables must be shielded to prevent interference and suitable for use at the temperatures and pressures you require. It must not be possible for air to pass through the cable if you are using an autoclave.

An autoclave pass-through can be constructed, consisting of a suitably pressure rated plate with one or more connectors on either side, into which cables can be plugged. Alternatively, a small copper tube can be used and the cables held in place with resin, however this is more difficult to use and not suitable for braided cables such as co-ax which may allow airflow out of the autoclave.

Advise, a manufacturer of dielectric sensing systems, has an example of this using co-ax cables, from which the following pictures are reproduced. This is one example, other systems use different connectors.

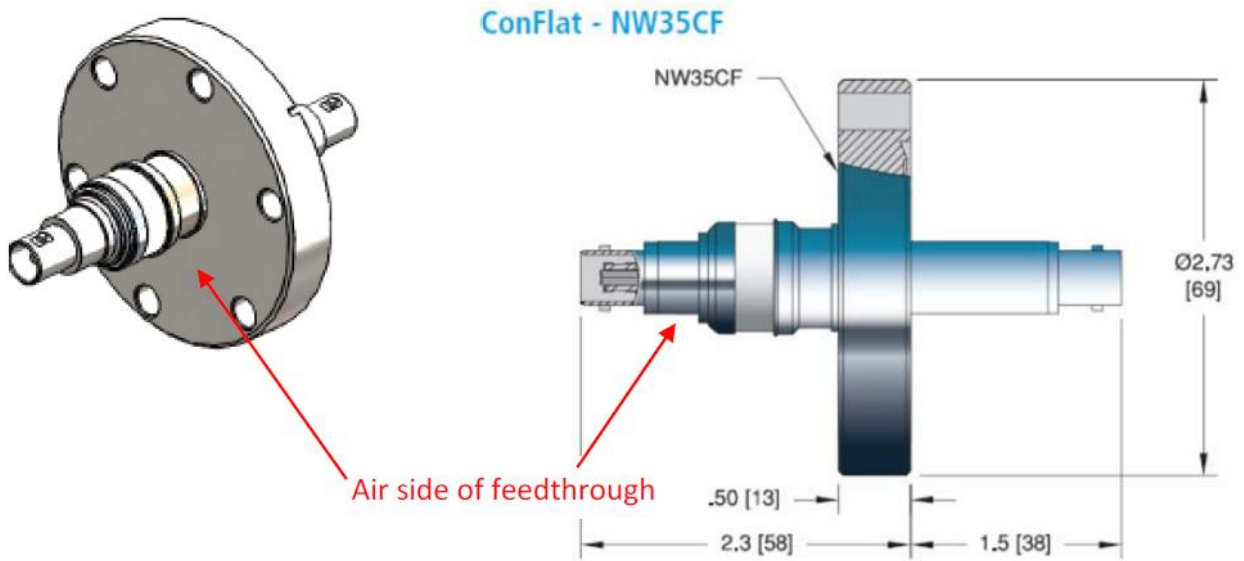

Figure x Co-ax cable pass-through, <http://www.advise-deta.com/>

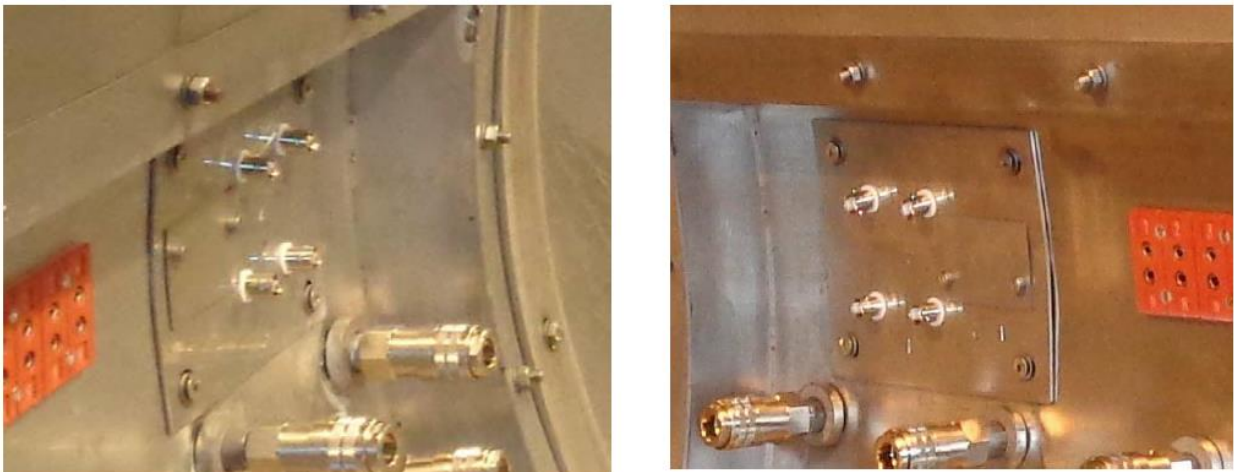

Figure y, Modifications to an existing autoclave, <http://www.advise-deta.com/>

If you do not wish to purchase a new autoclave/oven or modify a current one, it may be worth outsourcing your testing to somewhere which has this equipment available, at least as a preliminary step while deciding whether or not to proceed.

Tool mounted sensors- consider the cabling required for the sensors. A press or simple mould will need cables exiting from the outer surface and connecting to the analysis box. If there is room for cables, a press can be used without adjustment, meaning only the sensors, analysis box and computer are required.

Flexible sensors- as above, consider the cabling requirements. The sensors themselves are disposable as they remain in the part, so need to be bought repeatedly. For some systems, sensors



need to be soldered to the cable (and cut off thereafter), so in this instance soldering equipment and a suitable space must be available.

Resin cell- only purchasing (or outsourcing measurement) the resin cell, analysis box and software/a suitable computer is required. It is recommended to use the resin cell in a fume cupboard or well ventilated area.

2. At different Phases (Conceptual, Trade Study, Detail Design, and Production For:
  - a. Materials Deposition Management
  - b. Thermal Management
  - c. Quality Management
  - d. Residual Stress and Dimensional Management
- ii. Use in and effect on Tooling Decision Making
  1. Summary of Value Proposition

Tool mounted- the sensor should fit flush- as much as possible- to the tool surface, with as little edging present as possible to minimise marking on the part. When used in liquid moulding in particular, sealing the fixing well enough to prevent resin leakage is vital. Different manufacturers have different fixings.

The presence of the sensor may affect mould closure, particularly if it protrudes at all. It is necessary to test this. Precise tolerances may be required when machining the hole for the sensor and fixing. The cables will need to exit through the tool.

The more complex the part, the greater the chance that the sensor may not fit correctly and leakage may occur.

Placing glass fibre veils over the tool mounted sensors can be difficult as they need to remain in place throughout the process. They may need to be stuck down, and the presence of tape will affect the final part. The DC sensors may not require this, depending on the system being used.

When used in an autoclave or oven, it is important to ensure there is space for the cables to exit, through the trolley below the tool.

It is strongly recommended to place a sacrificial plate below the tool containing the sensor on first test, in case of resin leakage.

Flexible- the cables will need to exit along the tool surface.

Resin cell- will not be used with a tool.

2. At different Phases (Conceptual, Trade Study, Detail Design, and Production For:
  - a. Materials Deposition Management
  - b. Thermal Management
  - c. Quality Management
  - d. Residual Stress and Dimensional Management
- iii. Use in and effect on Part Decision Making
  1. Summary of Value Proposition

2. At different Phases (Conceptual, Trade Study, Detail Design, and Production For:

- a. Materials Deposition Management
- b. Thermal Management
- c. Quality Management

Tool mounted- the sensors may leave a mark on the part surface, so should not be placed anywhere that surface finish is critical, unless this can be achieved by machining. Note that a tool mounted sensor will only provide a surface measurement of cure. For thicker parts, a model may be required in conjunction with the measurement.

Flexible- these can be placed throughout the part, giving measurement of cure in any position. However, these remain in place after cure, which can be considered a defect (or a precursor to such). Sensors can be located in areas that will be removed after the cure, otherwise the part must be designed to take into account the structural issues caused by leaving the sensors in place. It may be prudent to use these sensors throughout the part during the prototyping stage, before moving to tool-mounted sensors (or thermocouples and a model which has been verified during prototyping) for production parts after the cure cycle has been chosen.

Resin cell- not relevant here as will not be used to make parts, except to note that material properties, which can be investigated using the resin cell, can affect your design choices.

d. Residual Stress and Dimensional Management

- iv. Use in and effect on Materials Decision Making (including process design)

**Use Cases**

Cure cycle optimisation at prototyping stage

Dielectric sensors can be used to track the progress of the cure. This means the cycle can be optimised to suit a given requirement- this may for example be the fastest cure cycle producing the required degree of cure, the most energy efficient, or finding a cure cycle which produces good results for a variety of different parts which must be cured together. Any of these, or indeed other factors, can result in cost savings- if the cure takes less time, more parts can be processed, or if energy use is minimised, energy costs are also minimised.

Investigating options for cure cycles at the prototyping stage allows use of embedded, flexible sensors to build up an understanding of cure throughout the thickness of that specific part, without needing them in final production parts where they would be considered defects.

Pro

Detailed understanding of cure throughout your prototype parts

Optimise the cure cycle to fit your business needs, saving time/energy and hence money

Verify models which can be used with thermal measurements or surface mounted dielectric sensors to monitor and/or control the cure of production parts

A good understanding in the prototyping stage means flexible sensors inside the part- which would become defects- will not be needed in production.

Avoid leaving the production part curing for longer than necessary 'just to be sure', hence saving time/energy/money.

Con

Cost of equipment and potentially modifying autoclaves/ovens to allow sensor use

May increase the time required for prototyping

If resin choice is changed or the manufacturer changes the formula, a repeat may be needed

Recommendations

If you are not likely to need this very often (depending how often you bring in a new design), hire the sensing equipment or outsource the study rather than buying it.

This can be done by trial and error without using a model if required, but for complex parts a model may be useful.

Resin choice

The response of different resins to different cure cycles can be studied- for small volumes of resin or prepreg samples using the resin cell, or in a prototype part when using the flexible or tool mounted sensors. The results can inform the choice of resin for the part.

Pro

Understand how different resins respond to different cure cycles

Experiment on a small scale with options other than the manufacturers' recommended cycle

Very little resin required

Equipment is small and self contained

Can be used in resin characterisation studies

Con

Cure of a thick part will be different to that of a small sample of resin

Cost of equipment

It is recommended to use the cell in a fume cupboard

Recommendations

If you do not undertake such studies often, hire the equipment or outsource the study.

For common resins, useful results may already exist in the literature.

1. Summary of Value Proposition
2. At different Phases (Conceptual, Trade Study, Detail Design, and Production For:
  - a. Materials Deposition Management
  - b. Thermal Management
  - c. Quality Management
  - d. Residual Stress and Dimensional Management
- v. Use in and effect on Producibility Decision Making (outcome evaluation)

### **Use Cases**

Resin arrival monitoring and control.

For liquid resin processes, wet-out can often be a problem. Monitoring the flow front by using dielectric or DC sensors to identify resin arrival at key points can either identify simple fixes (e.g. changing pressure application/resin volume/ inlet or outlet positions) or enable online control of the flow. Either way it is possible ensure the part is completely filled with resin. This will lead to fewer rejected parts, so can be of considerable value. A case study on this topic is included.

Pro

Ensure complete wet out- no more rejections due to dry spots

Understand cause of dry spots

Greater control of process

Traceable proof of flow and cure process

Con

Cost of equipment and new/modified tools

Surface marking from sensors

Recommendations

Use modelling or trial and error to identify the problem. If using a press

If dry spots are reliable and repeatable, a modification to the tooling or equipment is likely to be sufficient.

If racetracking occurs or the problem is intermittent, a control system similar to that discussed in the case study will be more suitable.

Where monitoring of the cure itself is not required, cheaper flow-only DC sensors should be adequate for the job.

### Online cure monitoring.

Monitoring the cure during manufacture can be used to ensure the required degree of cure is reached, reducing the number of rejected parts and providing a record of manufacture to the required parameters. This monitoring can be incorporated into an active cure control system, where temperature and/or pressure is automatically adjusted based on the measurements and a model.

#### Pro

Ensure required degree of cure is reached

Adjust cure profile based on current conditions

Traceable proof of cure process

No need to leave the part curing longer than necessary as a 'just in case' measure, saving time and money (on the heating) or increasing production rate.

#### Con

Cost of equipment

Surface marking or sensors left inside the part

Integration of cure monitoring equipment with autoclave or oven requires pass-throughs

#### Recommendations

Consider this if you are having degree of cure related problems, have a situation where conditions may vary a lot (such as an open cure tunnel in a factory) or need proof of the cure process.

If you use autoclaves or ovens, consider investing in pass-throughs when the time comes to buy new ones, even if you are not yet decided on this, as a future-proofing step. It is easier and cheaper to build into a new autoclave than to modify an existing one, as it would be offline for some time for the modification and need re-certifying afterwards. This can be done.

### Material status checking.

Out-time (the time where a resin or prepreg is not frozen), variation between batches, local conditions on the day and variations in mixing, among other things, can affect the properties of the resin. This means the requirements for the cure cycle may change. Ensuring the cure is correct for the material you have on that day should reduce failure rates, and the ability to adapt to different material statuses may increase the usability window of the material, reducing scrap of the raw material. A case study on this topic is included.

#### Pro

Identify when material has 'gone off' and should not be used -> fewer rejected parts

Expand potential material use window by modifying cure cycle to suit resin state

Con

Cost of equipment

Time and material taken to perform a test on a sample each day

Recommendations

A study akin to that in the case study needs to be performed for each material, as the results are resin-specific. This requires detailed analysis of data so outsourcing the study- akin to outsourcing a material characterisation study- may be a good option if you do not have suitably trained staff.

Use dielectric sensors, not DC, as the full range of results are needed. For consistency, the tests performed at the factory should use the same equipment as that used for the study.

1. At different Phases (Conceptual, Trade Study, Detail Design, and Production For:
  - a. Materials Deposition Management
  - b. Thermal Management
  - c. Quality Management
  - d. Residual Stress and Dimensional Management
- b. Case Studies of Application
  - i. Equipment Design, Selection, Implementation
    1. Background
    2. Motivation
    3. Implementation
    4. Value Proposition
    5. Summary and Conclusion, including recommendations
  - ii. Tooling Design, Selection, Implementation Background
    1. Motivation
    2. Implementation
    3. Value Proposition
    4. Summary and Conclusion, including recommendations
  - iii. Parts Design, Selection, Implementation
    1. Background
    2. Motivation
    3. Implementation
    4. Value Proposition
    5. Summary and Conclusion, including recommendations
  - iv. Materials Design, Selection, Implementation

This case study is based on a paper from Kim, Centea and Nutt of the University of Southern California, USA. For full details, read the paper.

## Monitoring the effect of out-time using dielectric sensors.

### 1. Background

Over time, as the resin 'goes off', chemical bonds gradually form, increasing viscosity and decreasing conductivity. This makes it harder to evacuate air and volatiles from the part during debulk and manufacture, as bubbles can be trapped in the more viscous resin or degassing pathways in the prepreg blocked off. Hence, part porosity is likely to increase with material out-time.

### 2. Motivation

The manufacturer will recommend a maximum out-time after which the prepreg should not be used. But this cannot take into account the local conditions, so a direct measurement of the state of the resin gives more information, which can be used to decide whether or not the material is usable and if so, which cure cycle should be used.

Out-time affects the part quality, as where the resin has become more solid, air and gases can no longer escape, so part porosity is expected to increase

### 3. Implementation

The authors used Advise's dielectric sensors, with a glass fibre veil, to monitor the chemical properties of an out of autoclave prepreg which had been left at room temperature for up to 49 days.

At multiple points over the course of those 49 days, samples were placed between two heated plates and in contact with the veiled dielectric sensor. This was used to measure conductivity at 30 degrees Celsius. The result is shown below.

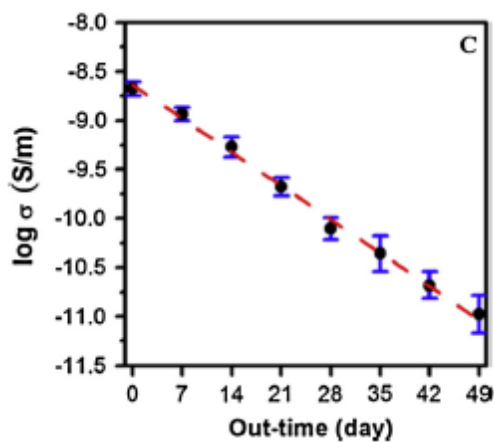

Figure Reproduced from Kim et al 2014. Decrease in conductivity of the prepreg with out-time.

A decrease in the conductivity indicates a higher ion viscosity.

The samples were then cured, for a variety of cure cycles. The results below are for isothermal dwell at the temperatures shown.

The results show a change in the cure response with out- time, as you can see below.

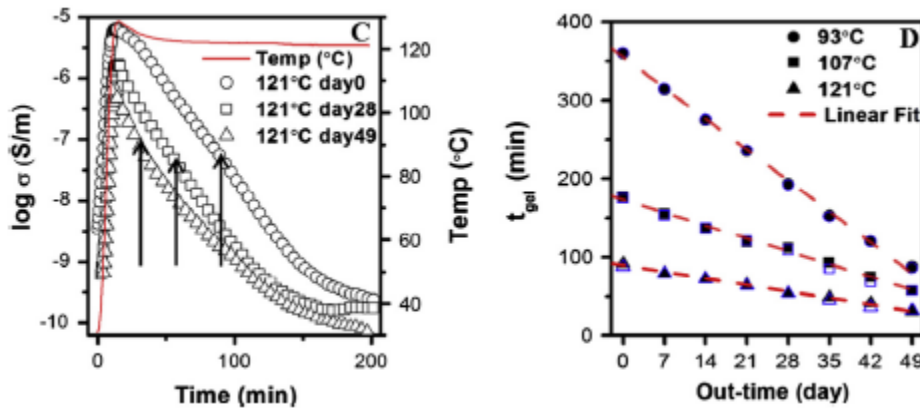

Figure. Reproduced from Kim et al 2014. Change in response to cure with out-time, and change in gel time with out-time.

As out-time increases,  $t_{gel}$ , the gelation time, gradually decreases and the peak conductivity seen during cure also decreases. Using dielectric sensors, full details of the cure response can be seen, which is discussed in more detail in the paper, and does have an effect on the optimum cure cycle.

These results can be used to determine the best cure cycle to use as the material ages, as this is likely to change, as shown below.

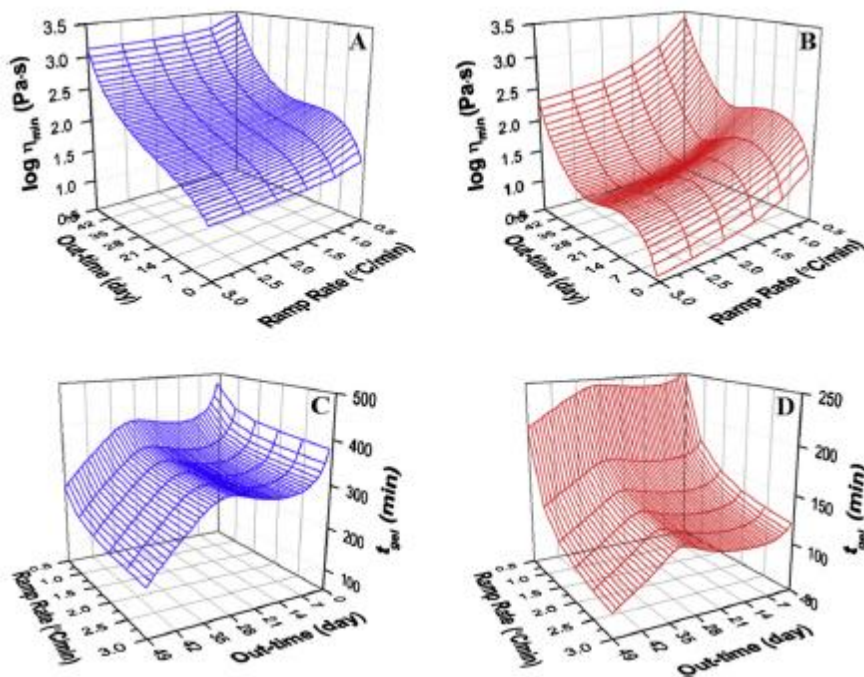

Figure. Reproduced from Kim et al 2014. Effect of out-time and ramp rate on  $t_{gel}$  and viscosity for cure at 93 degrees Celsius (in blue) and 121 degrees Celsius (in red).

#### 4. Value Proposition

These results demonstrate that a quick conductivity measurement at 30 degrees Celsius prior to laying up a new part can indicate whether or not the material is usable, and if so which cure cycle to use.



While the study is resin-specific, knowing this would allow a manufacturer to minimise time wasted preparing parts with material which is no longer usable- or to use material 'past the sell by date' if the measurements indicate it is still acceptable, by modifying the cure cycle to suit the resin state.

Pro

Identify when material has 'gone off' and should not be used -> fewer rejected parts

Expand potential material use window by modifying cure cycle to suit resin state

Con

Cost of equipment

Time and material taken to perform a test on a sample each day

#### 5. Summary and Conclusion, including recommendations

In order to make use of this, one must first perform a full study as in this paper, as the results are resin-specific. This aspect of the work could reasonably be outsourced if the technical expertise is not available in-house.

Using the results and the same dielectric monitoring equipment as that used in the study, a manufacturer could then add a conductivity check of a sample to the start of day process before layup begins. This will ensure the material is usable and inform the choice of cure cycle for that day.

The same process should be used when starting a new batch of material.

While this study used an out of autoclave prepreg, the principle of checking the material state before manufacture can be applied to other types of material.

#### v. Producibility Evaluation, Trouble Shooting, and Optimization

This case study is based on a lecture by Professor Suresh Advani of the University of Delaware, USA, used here with his permission. Full details can be found in the paper by Devillard, Hsiao and Advani.

#### **Control of flow in RTM using dielectric or DC sensors**

##### 1. Background

Resin Transfer Moulding is widely used in industry. Achieving full wet-out of the part can be problematic, particularly for more complex parts, leaving dry spots which render the part useless. Racetracking- where the flow front moves faster along the edge of the preform or an embedded feature- is a common problem, as the faster moving resin reaches the outlet gate first, leaving dry patches in the middle.

##### 2. Motivation

Locating the flow front within the part, using sensors, and comparing this to a model of possible flow paths in the tool allows the process to be controlled, mitigating the problems caused by racetracking. This means fewer rejected parts.

##### 3. Implementation

The authors designed a mould where racetracking is likely to occur, around a rubber insert or along the edges. The mould included flow sensors and controllable gates, operated by grippers. The setup is shown below.

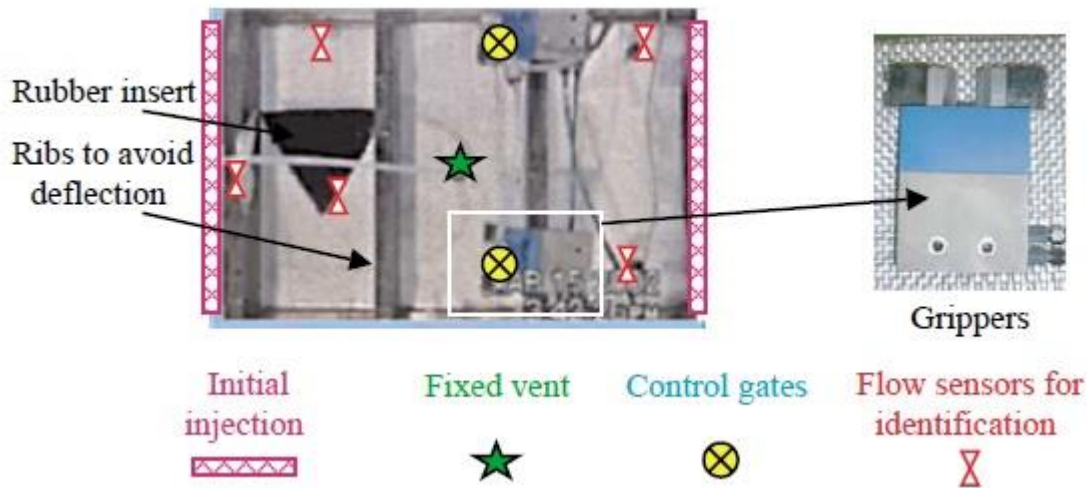

Figure. Reproduced from Devillard et al 2005. The gates can be controlled by computer, opening or closing to change the flow of resin within the mould.

A simulation of the injection was used to identify the possible flow scenarios, as racetracking does not always occur in the same place, or at all. The simulation found 32 possibilities. The authors then developed a control response for each of these, as shown below for a few examples.

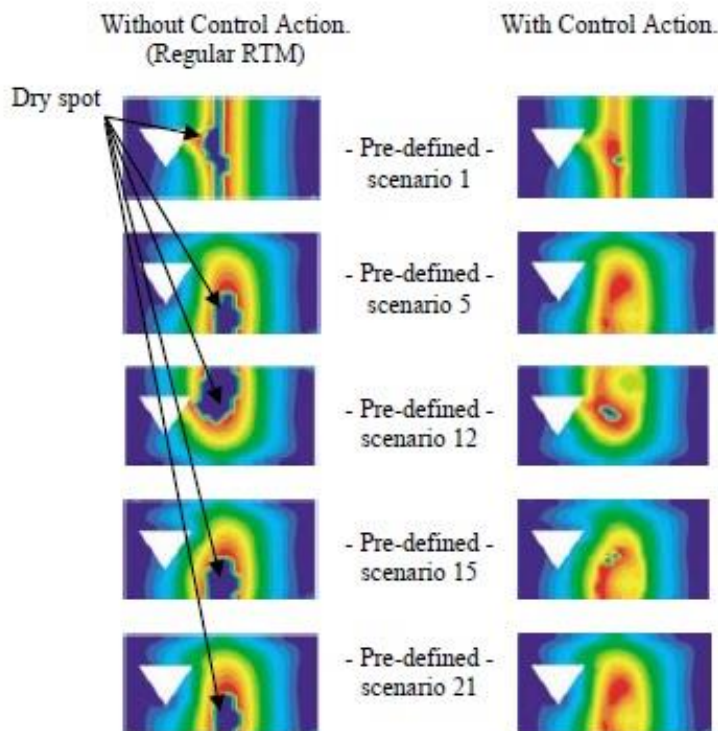

Figure. Reproduced from Devillard et al 2005. Flow scenarios and mitigating responses for 5 examples.

When an injection takes place, the resin arrival at the sensors is used to identify which scenario is occurring. The gates are then opened or closed as required to mitigate any possible dry spots. This is all controlled by computer. An example is shown below.

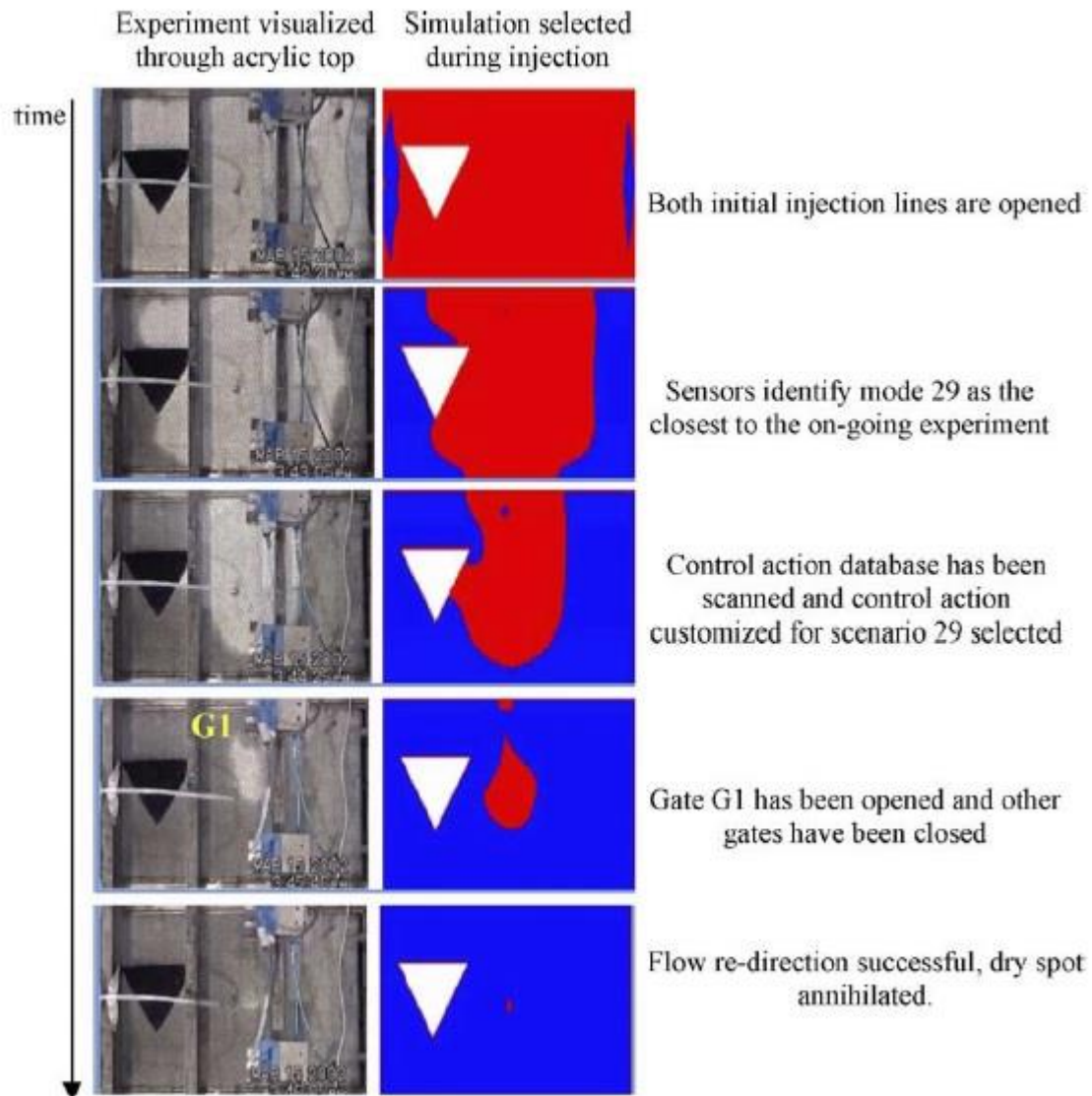

Figure. Reproduced from Devillard et al 2005. An example of the system in action.

#### 4. Value Proposition

Using a combination of dielectric or DC sensors, a model and active control gates, resin flow can be directed to mitigate problems caused by racetracking- or potentially other flow issues- and hence minimise or entirely remove dry spots.

Once the model is set up for any given part, this method could be used continually during production, to reduce failure rates due to dry spots.

Pro

Ensure complete wet out- no more rejections due to dry spots

Understand cause of dry spots

Greater control of process

Traceable proof of flow and cure process

Con

Cost of equipment and new/modified tools

Surface marking from sensors

#### 5. Summary and Conclusion, including recommendations

This method has the potential to dramatically improve yields from RTM processes, particularly for more complex parts.

The model and mitigation plan could if necessary be outsourced, if you do not have the expertise or the correct software in-house. For everyday use, only the results of the model and associated mitigation database will be required.

This requires a new approach to tooling, including sensors at key points and controllable gates to allow the flow to be directed appropriately.

If cure monitoring is not required, DC flow-only sensors may be the most cost effective option.

#### c. Industrial Standards and Statutory or Other Regulations

##### i. Industrial Standards

1. Aerospace
2. Automotive
3. Other

##### ii. Community or Common Standards

1. US
2. Canada
3. EU
4. Other

##### iii. Statutory Regulations

1. US
2. Canada
3. EU
4. Other

#### References for section 2

General reading

Advise website <http://www.advise-deta.com/>

Practical examples and instructions from Lambient <http://www.lambient.com/theory.htm>

Academic papers

Kim, D., Centea, T., Nutt, S.R., In-situ cure monitoring of an out-of-autoclave prepreg: Effects of out-time on viscosity, gelation and vitrification, *Composites Science and Technology*, Volume 102, 6 October 2014, Pages 132-138

Devillard, M., Hsiao, K-T., Advani, S.G., Flow sensing and control strategies to address race-tracking disturbances in resin transfer molding—part II: automation and validation, *Composites Part A: Applied Science and Manufacturing*, Volume 36, Issue 11, November 2005, Pages 1581-1589

## Appendix 8: List of Electronic Materials

The following files are included on the USB memory stick:

DielectricCureMonitoring.pptx	Knowledge Transfer Resource for Dielectric Cure Monitoring, as an interactive PowerPoint file. This is the recommended way to experience the material discussed in Chapter 6. Includes video and weblinks. 593MB
Dielectric cure monitoring.mp4	Video for Chapters 5 and 6. 164MB
In process XCT.mp4	Video for Chapter 4. 220MB
InProcessXCT_data.xlsx	Void volume, cure kinetics model and temperature baseline experiment data for Chapter 4 as Excel workbook. 222kB
AFPdefect_inprocess.gif	Animated .gif file from slices through CT reconstructions showing evolution of a tow gap, for Chapter 4. 5.72MB
Anonymous_section_combined.xlsx	Interactive (via pivot tables) Excel workbook of combined data from all participants for the anonymous section of the Knowledge Transfer Studies, for Chapter 3. 939kB
x_anonymised.xlsx	Anonymised version of data from named section of Knowledge Transfer Study questionnaire for x organisation. x = participating organisation or subgroup. For Chapter 3. Excel workbooks, 16 in total. 20-50kB each.
LRPickard_Thesis.pdf	Electronic copy of this thesis in portable document format. 15MB.

