

OPTIMA - Towards Demonstration of Flexible Photonic Telecom Payload

J. Anzalchi¹, Joyce Wong¹, V. Polo², T. Mengual², M. A. Piqueras², E. Prevost³, K. Ravel³, N. Parsons⁴, M. Enrico⁴, J. Bauwelinck⁵, M. Vanhoecke⁵, A. Vannucci⁶, M. Tienforti⁶

⁽¹⁾*Airbus Defence and Space, Stevenage, Hertfordshire, SG1 2AS, UK*
Email: javad.anzalchi@airbus.com, joyce.wong@airbus.com

⁽²⁾*DAS Photonic, Camino de Vera, s/n 46022 Valencia, Spain*
Email: vpolo@dasphotonics.com, tmengual@dasphotonics.com, mapiqueras@dasphotonics.com

⁽³⁾*SODERN, Avenue Descartes, 94451 Limeil-Brevanne, France*
Email: eddie.prevost@sodern.fr, karen.ravel@sodern.fr

⁽⁴⁾*HUBER+SUHNER Polatis Ltd, Cambridge Science Park, Milton Road, Cambridge, UK*
Email: nick.parsons@hubersuhner.com, michael.enrico@hubersuhner.com

⁽⁵⁾*imec - IDLab, Department of Information Technology at Ghent University, Belgium*
Email: johan.bauwelinck@ugent.be, michael.vanhoecke@ugent.be

⁽⁶⁾*Cordon Electronics, Via Guido Rossa, Cornate d'Adda 20040, Italy*
Email: antonello.vannucci@cordongroup.it, marcello.tienforti@cordongroup.it

INTRODUCTION

Incorporating flexibility in communication satellite payloads enables a given satellite on command to support different frequency plans, re-configure coverage in response to changing traffic demands and re-configure interconnectivity between coverages. In general flexibility would enable a satellite system to adapt to changing circumstances over its lifetime and thereby maximise its usefulness and profitability.

With Telecoms payloads based on traditional RF equipment, increase in capacity and flexibility has always translated into a more or less linear increase in equipment count, mass, power consumption and thermal dissipation. The main challenge of next generation of High Throughput Satellites (HTS) is therefore to provide a ten-fold-increased capacity with enhanced flexibility while maintaining the overall satellite within a “launchable” volume and mass envelope [1], [2], [3].

Photonic technology is a key enabler to tackle these issues. The use of Photonic technology in telecommunication satellites is a very promising technique to overcome the challenges to provide the capacity and flexibility to dynamically manage future telecommunication satellites payloads. The ability of Photonics to handle high data rates and high frequencies is critical in this scenario, with the added benefits of reduced size, mass [4], immunity to EMI and ease of harness routing (by using optical fibre).

In addition to the above mentioned characteristics, photonic technology will allow multiple and simultaneous signal mixing in a single device, which enables the reduction of the number of required equipment.

Photonics technology has already contributed to the revolution in Information Technology for terrestrial applications. However, a great deal of effort is required to bring these benefits to the world of telecommunication satellite payloads, as all of the photonics equipment used in space applications need to be adapted to endure the mechanical stress during launch and survive for at least 15 years in the harsh environment of a geo-stationary orbit (vacuum, thermal excursion, radiations).

This paper describes activities and progress in the OPTIMA project. OPTIMA is funded by the EU commission under Horizon 2020, COMPET-2-2016, maturing satellite communication technologies.

The OPTIMA project aims to demonstrate and validate the photonics payload concept and its benefits and provide a strong initial impulse to the photonics payloads for telecommunication satellites by focusing the efforts of various industrial and academic actors from the photonics and space European landscape towards the concrete goal of demonstrating the validity of the photonic payload concept and associated benefits.

Since photonic technology is not mature for use in the space environment, the OPTIMA project aims to develop and environmentally test to TRL 6 the necessary photonic hardware payload equipment. Furthermore the OPTIMA project aims to assemble the above equipment as a photonic payload demonstrator and perform further tests to TRL 6.

DEFINITION OF OPTIMA PAYLOAD DEMONSTRATOR REQUIREMENTS

The payload demonstrator for the OPTIMA project focuses on the needs of high capacity multi beam system evident in VHTS missions that supports greater than 250 narrow spot beams over the coverage area with frequency reuse. Recent study and Request for Information (RFI) conducted on these VHTS missions led to the definition of the OPTIMA demonstrator requirements, and further reinforces the benefits of adopting photonic technology to enhance such system. For example, Terabit/s Satellite Study [4] conducted by Airbus for ESA has revealed a possible saving of 25% on mass and 9% on power consumption compared to an equivalent RF payload.

Two recent RFIs, named in this paper as Mission 1 and Mission 2 were identified and their mission and payload characteristics were taken into account during the requirements definition phase alongside data from the Terabit Study. The main characteristics of the three VHTS missions studied are presented in Table 1.

Table 1 Comparison of main characteristics of VHTS missions

	Terabit Study	Mission 1	Mission 2
No. of satellites	1	1	3
No. of beams	260	359	300
Frequency bands of operation	Q/V & Ka gateways, Ka users	Q/V & Ka gateways, Ka users	Q/V & Ka gateways, Ka users
No. of gateways	33+4	18-20	16+1
DC power (kW)	~25	~22-23	~21-24 (per satellite)
Dissipation (kW)	~15	~17	~10-13 (per satellite)
Payload mass (kg)	~2580	~2290-2690	~1860-2130 (per satellite)
Total capacity (Gbps)	~1036	~442-504	~504-520 (per satellite)

The commonalities across all three missions are:

- The use of Ka-band and Q/V-band
- High number of beams, between ~260 beams to 360 beams, which translate to high mass, equipment count, power consumption and thermal dissipation.
- Frequency reuse; the available spectrum is subdivided into individual channels and translated via different LOs in order to re-assign a channel to a different beam.
- Large redundancy switch matrixes due to large equipment counts to improve reliability of the system.
- Flexibility of switching and routing of channels, sometimes involving digital processing and beam hopping.

The following considerations have been taken in determining the OPTIMA demonstrator requirements:

- To meet demanding requirements of VHTS missions using photonic hardware and to define demonstrator testing to verify that equivalent RF end-to-end payload performances can be met.
- Photonic component selections and packaging techniques to reduce mass, power consumption, footprint as well as meeting the demanding space environment reliability requirement.
- Enhance the way in which frequency reuse is supported by using photonic frequency converter capable of multiplexing channels using different conversion frequencies down a single optical path.
- Adopt optical switching to route any input to any output essential in a flexible multi beam mission.
- To Meet wideband requirement of VHTS missions; it is proposed for OPTIMA project to have RF interfaces at Ka-band only as it would be challenging to make wide band devices with acceptable performances that cover from 17.3GHz (Ka-band) to 51.4 GHz (V-band).

The transition from conventional RF payload architecture to photonic architecture is to be applied to the input section between LNAs and HPAs.

The number of LO frequencies required in a payload determines the extent of hardware savings which photonic technology can bring. Photonic frequency converter enables multiple frequency translation using one frequency mixer instead of multiple RF mixers. The output signals from different conversions are subsequently obtained using wavelength division de-multiplexing. This is in contrast to channelising the spectrum to go through separate mixers each with a different LO in a conventional RF architecture.

The feasibility of implementing photonic architecture for VHTS missions has been evaluated at payload level. A subset of paths are then selected for the demonstrator, with top level requirements flow down to equipment specification in order to align future development to real life scenarios. A simplified payload block diagram using photonic equipment is shown in **Fig 1**.

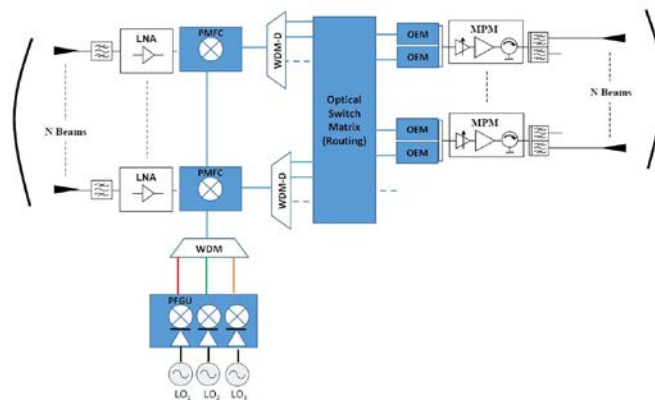

Fig. 1 Simplified payload block diagram using photonic equipment

Referring **Fig 1**, the signal from the antenna is amplified by an LNA and mixed with LOs coming from the Photonic Frequency Generation Unit (PFGU) at the Photonic Multi-Frequency Converter (PMFC). The optical signals are then routed through the Optical Switching Matrix (OSM) to the desired output beam, where it is photo-detected prior to entering the filtering and amplification RF chain before the output antenna.

PFGU, PMFC, OEM MODULES

The OPTIMA photonic payload demonstrator is composed of four units: PMFC, PFGU, OSM and Opto-Electronic Module (OEM). The demonstrator architecture is shown in **Fig 2**. Inputs to and outputs from the demonstrator are via coax cables at Ka-band frequencies, whilst all inter-equipment optical signals are connected via fibre-optic cables.

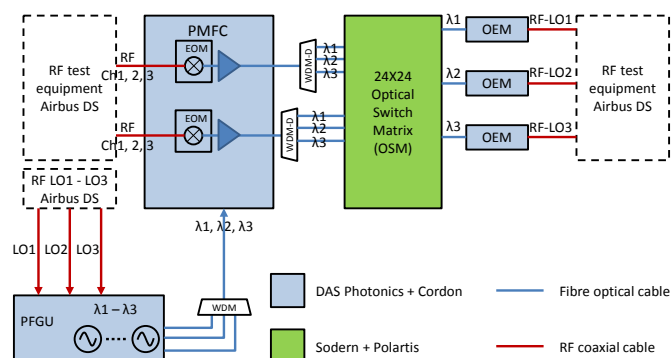

Fig. 2 OPTIMA demonstrator architecture

The OPTIMA photonic payload incorporates wavelength division multiplexers (WDM) and de-multiplexers (WDM-D) at the input and output of the PMFC (mixer) to allow LO multiplexing. DAS Photonics in cooperation with Cordon

Electronics is responsible for the development of PMFC, PFGU and OEM, while SODERN in cooperation with IMEC and Polatis is responsible for raising the TRL level and ruggedizing the OSM from HUBER+SUHNER Polatis. Airbus DS is responsible for the RF input and output test equipment.

PHOTONIC FREQUENCY GENERATOR UNIT (PFGU)

The PFGU is an optical transmitter based on external modulation that converts an electrical LO to the optical domain, integrating also optical amplification (OA) for power conditioning, as shown in **Fig 3** (left). The module comprises also the control and biasing electronics required to monitor and adjust parameters such as operation wavelength, temperature, output power, etc. In OPTIMA, particular effort has been devoted to the miniaturization of photonic modules and CORDON Electronics has been responsible for developing a co-packaged Laser-Modulator, shown in **Fig 3** (center). The device has already been fabricated and comprises a DFB laser chip, a LiNbO₃ modulator chip, monitoring photodiodes chips, built-in TEC and coupling and mounting benches. The package is hermetically sealed. The measured RF response **Fig 3** (right) confirms that operation up to 40 GHz band is possible.

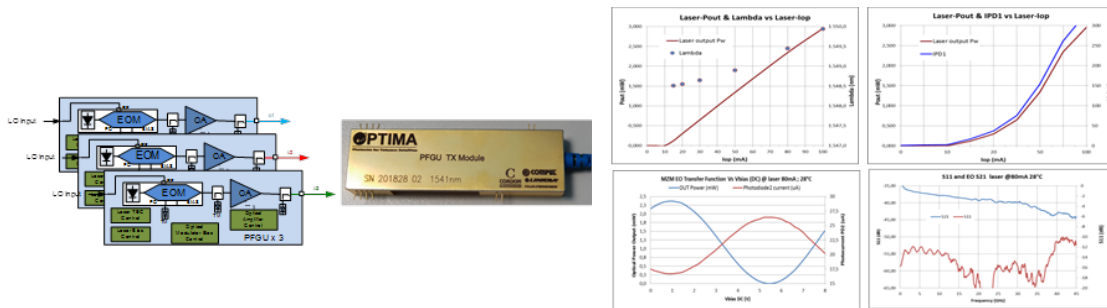

Fig. 3 Block diagram of photonic frequency generation unit (left), picture of the co-packaged laser modulator device (center) and simulated and measured characteristic curves of the PFGU Tx module (right).

PHOTONIC MULTI-FREQUENCY CONVERTER (PMFC)

This assembly mixes the photonic LO with an RF signal. The mixing process is performed by an optical modulator that is in charge of modulating the RF signal on the wavelengths generated by the PFGU. This assembly also integrates optical amplification (EDFA fabricated by DAS Photonics) for power conditioning. The block diagram of the PMFC, as well as the optical spectrum at the different interfaces is shown in **Fig 4**. The optical carrier modulated by the LO signal (shown in red, the one corresponding to the laser at λ_1 and the two LO side-bands) is modulated by the RF signal. The LO carrier with more power (laser) generates one side-band with the RF signal information at an offset equal to the input frequency. The secondary LO carriers also generate the same RF side-band at the same offset frequency, but offset with respect to the laser carrier is incremented by the LO frequency in one case, and decremented by this same quantity in the other case. The same process applies also for all the LO carriers generated by the PFGU. As described in next Section, this optical spectrum generates up and down conversions once a homodyne mixing is performed in the OEM.

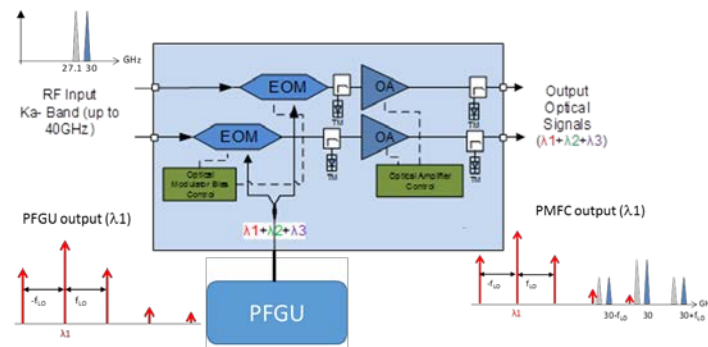

Fig. 4 Block diagram of photonic multi-frequency converter (PMFC)

OPTICAL TO ELECTRICAL MODULE (OEM)

The OEM is composed of a 40 GHz Linear InGaAs PIN Photodetector and the associated circuitry. The coplanar waveguide photodiode design optimizes speed and sensitivity for the 1250 nm through 1650 nm wavelength range, and assures a 30 GHz frequency response necessary for OPTIMA specifications. As shown in **Fig 5**, the optical signal with the multiple mixing products generated in the PMFC is converted from optical to electrical in a homodyne detection process, which mathematically is described as:

$$I_{PD}[A] = R[A/W] \times |E_{OPT}|^2[W] \quad (1)$$

Where, I_{PD} is the photo detected current, R is the responsivity (the capacity to convert optical power into current) and E_{OPT} is the optical field arriving to the photodiode. The square of the modulus of the optical field generate mixing products of the E_{OPT} by itself, as well as other mixing products generated by the different LO carriers with the RF side bands. The IF electrical spectrum after the photodetector is shown in **Fig 5**, composed of harmonics of the f_{LO} frequency ($n \cdot LO$, $n=1,2,\dots$), replica of the input RF signal and mixing products of the input RF signal with the LO at $f=f_{RF} \pm n \cdot f_{LO}$. The desired mixing product is selected by an IF filter at the OEM output prior to be amplified and fed to the antenna. As this filter is in the IF domain, the photonic payload can be used at any RF, LO and IF frequency.

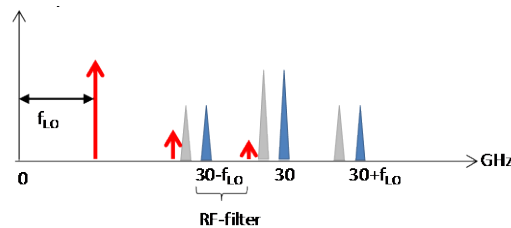

Fig. 5 IF spectrum after optoelectronic conversion

OPTICAL SWITCH MODULE

The optical switch is at the core of the photonic payload. It enables the routing of signals from any input port to any output port providing a high flexibility to the payload. It is fully transparent and can handle 1.55 μm signals independently of their wavelengths, intensity and modulations.

In OPTIMA project, Sodern and HUBER+SUHNER Polatis are raising the optical-mechanical core technology up to qualification level by leveraging the state of the art DirectLight® terrestrial technology from Polatis.

The current Polatis optical switch matrix addresses the terrestrial telecom and datacenter markets, with a core technology currently supporting up to 384x384 ports. This is the only identified solution for addressing a large number of ports while reaching 1dB of insertion loss for space applications. **Fig 6** shows the principle of the DirectLight®.

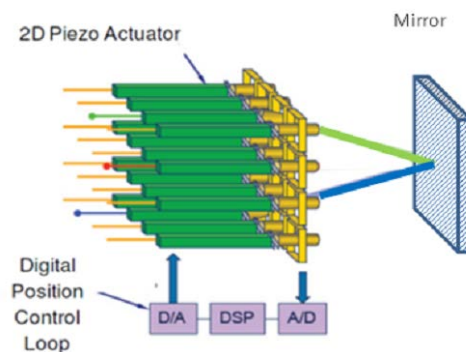

Fig. 6 DirectLight® core technology with mirror reflection based configuration

Each input fiber is terminated by an optical collimator to generate a parallel beam. The collimator orientation is piloted by a 2D piezoelectric actuator. The position is controlled by a local closed loop using an integrated position sensor in order to cancel piezo hysteresis, creep and drift. The collimator is then pointed to the desired output oriented collimator. The output collimator focuses the beam on the fiber end, and injects the light in the fiber. The link between two ports is established when input collimator and output collimator are aligned facing each other.

At optical switch level the main objectives in the frame of OPTIMA project were:

- to validate that the Polatis DirectLight® technology can be used for space and demonstrate overall absence of showstoppers regarding the critical space environment or processes and materials,
- to design, manufacture, test and qualify a 48-port Switch Core Unit breadboard (24 inputs - 24 outputs) with Polatis COTS EEE (Thermal Vacuum, vibrations, shocks),
- To deliver the breadboard for implementation and testing in the OPTIMA Payload Demonstrator to demonstrate steps to TRL 6.

MATERIALS AND PROCESS OF DIRECTLIGHT® TECHNOLOGY

Sodern with support from Polatis has performed an in-depth analysis of DirectLight® core technology materials and processes. About 15 materials, 5 mechanical parts and 20 processes, of the manufacturing line (machines, tools, test benches, monitoring too), electronic assemblies, soldering, gluing and welding processes have been successfully reviewed to determine their compatibility with space standards.

SWITCH ASIC RADIATION EVALUATION

The latest, most compact, optical switch products of Polatis uses a high-voltage CMOS ASIC to drive piezo-actuators that has been specifically designed for the terrestrial communication market switch [5]. IMEC with the support of Sodern has performed first evaluation of the capacity of the ASIC to withstand radiations as shown in **Fig 7**. The aim was to evaluate the possibility to reuse this ASIC which was not specifically designed for use in space environment.

First, Total Ionizing Dose tests have been performed. There was no degradation up to 27 krad, however, a full loss of functionality has been observed at 59 krad. In depth shielding analysis has demonstrated that the use of a 3.5 mm thick packaging would be sufficient to make the ASIC compatible with the GEO environment.

Second, the sensitivity to single event effects induced by heavy ions has been tested. Failure of samples has been observed at low energy (LET of 5.7 MeV.cm²/mg) and flux (1E5 particles/cm²) at nearly the same spot despite the use of an external de-latching circuit protection. The failure mechanism has been identified as a Single Event latch-up or a Single Event Burnout. This means that the ASIC cannot be used as is in the GEO environment due to its high sensitivity to heavy ions.

In order to better understand the exact origin of the internal failure, a laser spot scanning test of the ASIC has been performed. The conclusion is that several circuits of the ASIC are sensitive to injection of charges. As a consequence a local modification of the terrestrial ASIC will not be sufficient to improve its robustness with regards to Heavy Ions.

IMEC, Polatis and Sodern are now investigating different options for the redesign of a new ASIC for use in orbit. Most issues can be addressed by well-known design and layout techniques, however, the high-voltage part makes the new design particularly challenging and will require a change in ASIC technology. A major failure was traced back to a cross-voltage-domain path, present due to limited high-voltage ESD protection available in the current CMOS process.

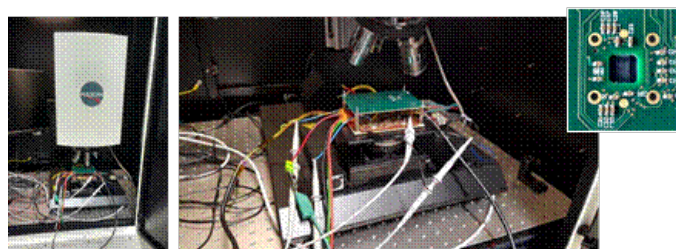

Fig. 7 ASIC laser radiation tests

48-PORT SWITCH BREADBOARD DESIGN

Sodern has performed an extensive vibration test campaign on Polatis switch core technology to characterize its dynamic mechanical behavior and the cause of vibration failures observed at relatively low input level compared to the vibration environment induced by rocket launch.

In parallel Finite Element Modeling Analysis has been performed to establish a correlation with experimental results and numerical test improvement solutions. Simulations have shown that several vibration modes were the reason for the failure. The local stiffening of some elements (via a change of material and design), and the use of mechanical dampers have been identified as solutions to dramatically enhance the robustness with respect to vibration and shock. Based on these results a 48-port switch breadboard has been designed and manufactured jointly by Sodern and Polatis as shown in **Fig 8**.



Fig. 8 Picture of the OPTIMA 48-port switch breadboard

FULLY INTEGRATED PAYLOAD DEMONSTRATOR

The photonic payload system to be designed, developed and tested to TRL6 in OPTIMA is shown in **Fig 2**.

Final mechanical designs for the PFGU, PMFC, OSM and OEM, including size, power consumption and mass estimation is shown in **Fig 9**. Each unit will have its own DC power and TM/TC interfaces as well as the specific optical and RF ports representative of a real implementation (e.g. mini-AVIM optical connectors). The demonstration will comprise of three laser wavelengths set in ITU channels centered at 1558.17 nm, 1549.32 nm, and 1541.35, and the electrical LO frequencies selected for the demonstrator are 9, 10.5 and 12 GHz. A fully functional validation will be carried out, measuring performance parameters such as system conversion gain, SFDR, noise figure, etc, as well as performing a fully functional dynamic validation demonstrating the flexibility of the photonic payload in terms of channel selection, routing and allocation. The TT&C system will be validated as well.



PFGU:
Size: 238x111.5x100 mm
Power: 11.11W max
Mass: 800g



PMFC:
Size: 200x130x59 mm
Power: 8.02W max
Mass: 1100g



OSM:
Size: 330x200x200 mm
Power: 5W max
Mass: 3600g



OEM:
Size: 80x38x17.75 mm
Power: 0.05W max
Mass: 100g

Fig. 9 Mechanical design of OPTIMA modules, from left to right: PFGU, PMFC, OSM and OEM.

OPTIMA is aiming to reduce the SWaP (Size, Weight and Power) of the payload by optimizing the photonic modules integration and using optical fibre instead of coaxial or waveguide transmission lines in a distributed architecture to facilitate the adoption of the photonic technology for space applications. Some of the key photonic components have previous heritage or are rad-hard parts, and others are being developed within the project to achieve TRL 6. On average, the goal of the activity is to demonstrate a reduction at payload level for HTS applications in size and weight of 50%, and a 10% power consumption reduction compared with traditional RF implementations.

Building blocks of OPTIMA will reach TRL6 by early part of 2019. In-orbit Demonstration and Verification (IOD/IOV) as early as 2021 can be envisaged as shown in **Fig 10**.



Fig. 10 OPTIMA development and IOD/IOV timeline

CONCLUSION

The present paper has outlined the progress and development status of a photonic payload hardware demonstrator under the OPTIMA project.

To collate most up-to-date payload requirements specification for the type of high throughput broadband mission that the OPTIMA project is targeted at, recent VHTS RFIs have been included in addition to the previously terabit/s satellite study.

The optical switch matrix has passed the vibration, shock and thermal vacuum tests successfully. The other equipments in the demonstrator chain are now going through the final stages of assembly and testing before being environmentally tested. The successful environment testing of the OPTIMA switch breadboard paves the way to the development of a Space version of the DirectLight® switching technology in order to address the GEO communication satellite market.

An EGSE simulating the PDU and PSU and implementing the TT&C systems is under development in order to fully validate functionality of the developed PFGU, PMFC, OSM and OEM modules. A CAN bus architecture is being designed and will be implemented in the demonstrator.

ACKNOWLEDGEMENTS

The authors would like to express their appreciation and gratitude to the European Commission and European Space agency for their continued support, funding and expert advice in the optical and photonic technology domain.

REFERENCES

- [1] D. Mignolo, P. Angeletti, E. Re, A. Alamanac, M. Harverson, A. Ginesi, "Approaching Terabit/s Satellite: a System Analysis", 17th Ka and Broadband Communications, Navigation and Earth Observation Conference, October 2011, Palermo, Italy.
- [2] G. Verelst, O. Vidal, E. Alberty, D. Galinier, N. Metzger, P. Inigo, S. Stirland, G. Huggins, "Innovative System Architecture to reach the Terabit/s Satellite", 19th Ka and Broadband Communications, Navigation and Earth Observation Conference, October 2013, Florence, Italy.
- [3] P. Inigo, O. Vidal, B. Roy, E. Alberty, N. Metzger, D. Galinier, J. Anzalchi, G. Huggins, S. Stirland, "Review of the Terabit/s Satellite, the Next Generation of HTS Systems", 7th Advanced Satellite Multimedia Systems Conference (ASMS) and 13th Signal Processing for Space Communications Workshop (SPSC), September 2014, Livorno, Italy.
- [4] J. Anzalchi, P. Inigo, B. Roy, "Application of Photonics in Next Generation Telecommunication Satellites Payloads", International Conference on Space Optics, ICSO-2014, October 2014, Tenerife, Spain.
- [5] N. Parsons, R. Jensen, A. Hughes, "High radix all-optical switches for software-defined data center networks", 42nd European Conference on Optical Communication (ECOC), September 2016, Dusseldorf, Germany.
- [6] Karen Ravel, Charlie Koechlin, Eddie Prevost SODERN, Nick Parsons, Michael Enrico, Sean Barker HUBER+SUHNER POLATIS LIMITED "Optical Switch Matrix development for new concepts of Photonic based flexible Telecom Payload", ICSO-2018, October 2018, Chania, Greece