



Citation for published version:

Shivaprasad, P, Jones, M, Frith, PE & Emanuelsson, EAC 2020, 'Investigating the effect of increasing cloth size and cloth number in a spinning mesh disc reactor (SMDR): A study on the reactor performance', *Chemical Engineering and Processing: Process Intensification*, vol. 147, 107780.
<https://doi.org/10.1016/j.cep.2019.107780>

DOI:

[10.1016/j.cep.2019.107780](https://doi.org/10.1016/j.cep.2019.107780)

Publication date:

2020

Document Version

Peer reviewed version

[Link to publication](#)

Publisher Rights

CC BY-NC-ND

University of Bath

Alternative formats

If you require this document in an alternative format, please contact:
openaccess@bath.ac.uk

General rights

Copyright and moral rights for the publications made accessible in the public portal are retained by the authors and/or other copyright owners and it is a condition of accessing publications that users recognise and abide by the legal requirements associated with these rights.

Take down policy

If you believe that this document breaches copyright please contact us providing details, and we will remove access to the work immediately and investigate your claim.

1 **Investigating the effect of increasing cloth size and cloth number in a Spinning Mesh Disc Reactor**
2 **(SMDR): A study on the reactor performance**

3 **Parimala Shivaprasad¹, Matthew David Jones², Paul Frith³, Emma Anna Carolina Emanuelsson^{1*}**

4 *¹Department of Chemical Engineering, University of Bath, Claverton Down, Bath BA2 7AY, UK,*

5 **eaep20@bath.ac.uk*

6 *²Department of Chemistry, University of Bath, Claverton Down, Bath BA2 7AY, UK*

7 *³Engineering and Design technical services, University of Bath, Claverton Down, Bath BA2 7AY, UK*

8
9 **Abstract**

10 The spinning mesh disc reactor (SMDR) is a rotating catalytic reactor with a potential to facilitate process
11 intensification. In this study, the scale-up of a newly designed SMDR has been demonstrated by increasing (i)
12 cloth size and (ii) cloth number for tributyrin hydrolysis and nitroaldol condensation reaction. The effect of
13 spinning speed, cloth size and cloth number was investigated using design of experiments and the results show
14 an increase in the cloth size or cloth number leads to a higher reaction rate. This is due to (i) an increased
15 catalyst loading with increase in surface area and volume of the cloth stack and (ii) reduced film thickness
16 with increasing shear forces and longer residence times improving the overall mass transfer. Addition of
17 multiple cloths of increasing cloth sizes further improved the reaction rates at higher substrate concentration.
18 A maximum reaction rate of 6.9 mM min⁻¹ and 0.043 mmol min⁻¹ was obtained for three 50 cm cloths for
19 tributyrin hydrolysis and nitroaldol condensation reaction respectively. These results highlight the potential
20 routes for the SMDR scale-up without a loss in the reaction efficiency for a range of catalytic reactions, thus
21 allowing for a tuneable operation of the SMDR for industrial applications.

22 **Keywords**

23 Spinning mesh disc reactor; reaction scale-up; increased catalyst loading; multi-cloth stack; reaction
24 intensification

27 1. Introduction

28 Scale-up of traditional reactors is straightforward but accompanied by high mass and heat transfer resistance
29 impeding the reaction rate and reduced product yield. Hence, careful consideration of the reaction system is
30 necessary to ensure a sustainable process scale-up as they often involve large quantities of solvents and
31 expensive catalysts. This can be overcome by achieving a better control over the reaction at a molecular level
32 and follows a new development path in chemical processing known as process intensification (PI) [1]. PI can
33 be achieved either by modifying the reactor design or employing innovative reaction techniques. One of the
34 more popular approaches of PI is to achieve a reduction in the size of the chemical equipment or simplify its
35 scale-up whilst maintaining the production efficiency [2]. This has led to the concept of ‘numbering-up’,
36 where process scale-up is achieved by adding more reactor units in series or parallel. Generally, numbering-
37 up reduces the reactor size, promoting safe operating conditions by confining the operating area to a smaller
38 space, especially for reactions involving hazardous chemicals.

39 The Spinning disc reactor (SDR) is an intensified reactor which uses centrifugal force to drive the reaction
40 fluid to a thin film of high shear on the surface of the spinning disc[3]. Scale-up in the SDR has been
41 demonstrated by either increasing the disc size or by adding more discs (‘numbering-up’) to the central shaft.
42 Scale-up by increasing the disc size in the SDR has been achieved for production of polyurethane [4]. A
43 modification of the SDR is the rotor stator spinning disc reactor, where it has been shown that addition of
44 multiple rotors to the central axis resulted in improved mass and heat transfer coefficients for multi-phase and
45 catalytic reactions [5, 6]. The spinning mesh disc reactor (SMDR) is another variation of the SDR, which
46 additionally houses a mesh cloth support with immobilised catalyst on the disc. The reaction liquid impinged
47 on to the centre of the spinning disc allows for the formation of a thin film of high shear over and within the
48 cloth surface, facilitating rapid liquid mixing and enhanced mass transfer. Further, residence time distribution
49 studies has shown that addition of cloths in the SMDR causes a significant deviation from the plug flow
50 behaviour reported for a conventional SDR, indicating that the flow property resembles a well-mixed reactor
51 [7].

52 Reaction intensification has been demonstrated by using catalysts immobilised on the wool for: (i) lipase
53 catalysed hydrolysis of tributyrin [8-10], (ii) Henry reaction catalysed by copper triflate [11] and (iii) kinetic

54 resolution of racemic alcohol catalysed by amano lipase [12] and improved reaction efficiency was achieved
55 in all the cases compared to the batch reactor. Process scale-up in the SMDR has been achieved through the
56 concept of numbering-up by addition of more catalyst cloths on to the disc. Significant improvement in the
57 reaction rate and productivity ($\text{g l}^{-1} \text{h}^{-1}$ of product formed) has been observed for the systems described above
58 with the increase in the number of catalyst cloths. This demonstrates that the transition of SMDR from a
59 laboratory process to an industrial scale operation is accompanied by minimum alterations to the original
60 reactor design without compromising on the overall process efficiency. However, the studies till date have
61 only been carried out with a maximum cloth size of 25 cm and a comprehensive scale-up study for increasing
62 cloth diameter and numbering-up of larger cloths for a range of reactor parameters has not been explored.

63 The aim of this study is thus to investigate and compare the performance of the SMDR when scale-up is
64 achieved by (i) increasing the catalyst cloth size and (ii) numbering-up of cloths (of similar and increasing
65 diameters). Two different reactions: enzymatic hydrolysis of tributyrin (aqueous system) and nitroaldol
66 condensation reaction catalysed by copper triflate (organic solvent system) have been chosen for this study as
67 we have previously optimised both reactions in the SMDR and they have also shown potential for application
68 in pharmaceutical and fine chemical industry. The reactions will be carried out in a newly designed reactor
69 with an optimised nozzle design to minimise the spin-up zone and also improve the contact between the
70 reactant and the cloth surface. The effect (individual and simultaneous) of increasing cloth diameter (20 cm
71 to 50 cm) and number of cloths (one to three) on the reaction rate will be investigated using design of
72 experiments. The reactor performance will also be examined as a function of film thickness and mean
73 residence time.

74 **2. Material and methods**

75 *2.1 Materials*

76 All of the chemicals and lipase from *Pseudomonas fluorescens* was obtained from Sigma Aldrich and used as
77 received. Saskatoon knitted woollen blanket (cream colour, 1.5 mm thick, 0.32 g cm^{-2}) was obtained from
78 Urbanara (Berlin, Germany). Deionised water was used to prepare all standard solutions and buffers.

79 *2.2 Immobilisation of lipase on wool*

80 The general protocol used for lipase immobilisation on wool is as reported in [10], with modifications to
81 reagent concentrations based on the weight of the woollen cloths used in the present study. To summarise,
82 circular pieces of different diameters (20 cm, 30 cm and 50 cm) were cut from a woollen blanket cloth. Pre-
83 treatment of the cloths was carried out using a solution of sodium silicate and hydrogen peroxide in a pH 9
84 buffer for 70 minutes. The cloths were then soaked in a solution of 2% polyethyleneimine (PEI) at pH 8 for 2
85 hours and washed with deionised water, after which they were soaked in a solution containing 2 gL⁻¹ lipase in
86 a pH 6 phosphate buffer for 24 hours. Finally, the cloth was dipped in a 0.5% glutaraldehyde solution in pH 6
87 phosphate buffer for 10 minutes to facilitate enzyme cross-linking and rinsed with deionised water to remove
88 any unbound enzyme from the cloth surface.

89 *2.3 Copper triflate immobilisation on wool*

90 The detailed protocol has been published in our previous publication [11]. The procedure for copper
91 immobilisation is similar to that of lipase on wool. The woollen cloths after the PEI treatment were soaked in
92 copper triflate solution (1mM) in methanol for 24 hours. The crosslinking of copper cloths were carried out
93 in a similar manner to that of lipase cloths.

94 *2.4 Reactions in the SMDR*

95 As shown in Fig.1, the SMDR consists of a circular disc fastened with the catalyst cloth and connected to a
96 central rotating shaft within a circular housing. The spinning speed is controlled via a variable speed controller
97 and the disc is driven by a three phase AC motor. The inlet reaction liquid from the reactant vessel is pumped
98 through the central rotating shaft and through a nozzle located at the centre of the disc. The liquid at the centre
99 of the disc has the same speed as the spinning disc, hence minimising the spin-up zone from the centre of the
100 disc when the reactant comes in contact with the disc. This maximises the area of contact between the cloth
101 and the reactant, ensuring a uniform coverage of the cloth. The spin-off from the edge of the disc passes
102 through circular ports located around the casing and into a reservoir from where it is pumped back into the
103 reaction vessel. The disc and the housing are made of hard anodised aluminium and the inlet port tubing is
104 stainless steel, to improve the overall solvent resistance of the reactor.

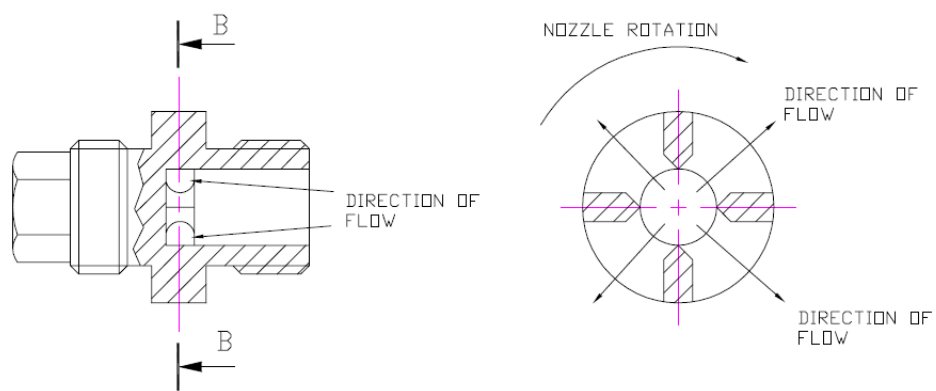
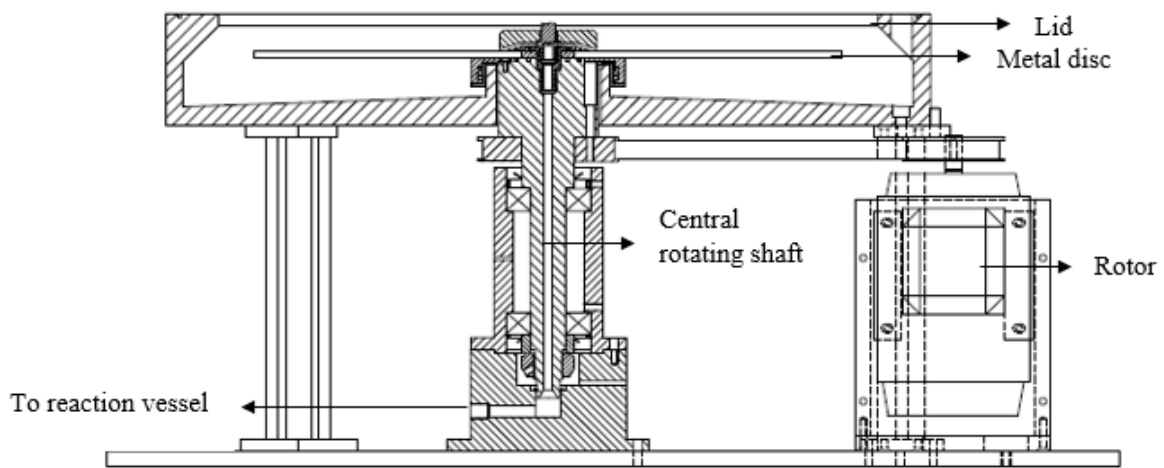

(a)



(b)

Figure.1 (a) Schematic diagram of the SMDR and nozzle design and (b) photograph of the SMDR

(a) Tributyrin hydrolysis in the SMDR

120 An emulsion of tributyrin was prepared by adding Triton X-100 (3.5 gL⁻¹) and tributyrin to 1000 ml of pH 7
121 phosphate buffer (0.1M) such that the final concentration of the reagents were and 33 mM respectively and
122 Fig 2 shows the reaction scheme.

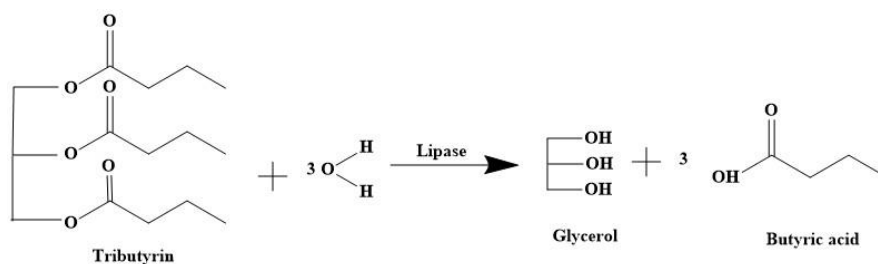

123

124

Figure.2 Reaction scheme for enzymatic hydrolysis of tributyrin

125 The mixture was emulsified at 1000 rpm for 10 minutes. Lipase cloth of the desired size was fastened to the
126 disc using the screw at the centre of the reactor and the reactor was covered with a Perspex lid. The reaction
127 mixture was fed to the reactor via a peristaltic pump at a flowrate of 3 ml s⁻¹ and rotated at the desired speed.
128 The reaction was run for 3 hours at 45°C. A pH stat (Titroline, SI analytics) was used for continuous addition
129 of sodium hydroxide to maintain a constant pH and the data was recorded continuously onto a PC using a
130 hyperterminal software. The reaction conversion was determined as follows [9]:

131

$$\text{Conversion}(\%) = \frac{\text{moles of free butyric acids}}{\text{moles of original esters in tributyrin}} \times 100$$

132 The initial reaction rate was calculated from the slope of the hydrolysis curve obtained from the pH stat. All
133 data points were used from the start of the reaction till the slope began to decrease, which indicates the end of
134 the initial rate period [13].

135 (b) Nitroaldol condensation reaction in the SMDR

136 The reaction mixture consisting of benzylamine (1 mmol), trimethylamine (0.16 mmol), nitromethane (10
137 mmol) and dodecane (0.5 mmol, internal standard) was dissolved in 500 ml ethanol and Fig.3 depicts the
138 reaction scheme.

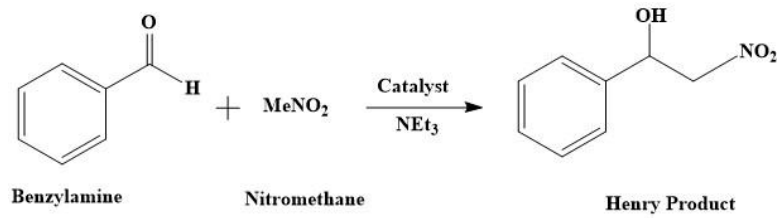

Figure.3 Reaction scheme for nitroaldol condensation (Henry) reaction

The copper catalyst cloth was fastened to the disc in the reactor and the reactor was covered with a Perspex lid. The reaction was initiated by switching on the peristaltic pump once the reactor has reached the desired RPM. The reaction was carried out at 25°C for 3 hours. Samples were taken every 5 minutes during the first 30 minutes of the reaction and thereafter for every hour till the end of 3 hours. The samples were analysed using gas chromatography (GC) using a method described in our earlier publication [11]. The first order reaction rate was calculated for the first 60 minutes of the reaction time period.

The average surface shear (\bar{S}) was used to characterise the reactor performance based on the cloth size and the spinning speed for both reactions as follows [9]:

$$\bar{S} = \frac{1}{R} \int_0^R S dr = \frac{3}{4} \left(\frac{3QR\omega^4}{2\pi\nu^2} \right)^{1/3} \quad (1)$$

where, S = surface shear (s^{-1}); Q = volumetric flow rate ($m^3 s^{-1}$); R = radius of the disc (m); ω = angular velocity ($rad s^{-1}$); ν = kinematic viscosity ($m^2 s^{-1}$). A maximum spinning speed of 450 RPM was used for all experiments to operate the reactor below the critical shear stress value.

The resulting film thickness (f) as a function of the spinning speed was calculated using the following equation [14]:

$$f = \left(\frac{3\mu Q}{2\pi\rho R^2\omega^2} \right)^{1/3} \quad (2)$$

where, f = film thickness (m); μ = liquid viscosity (Pa s)

The mean residence time (t) of the liquid feed on the cloth surface was calculated as follows [14]:

$$t = \left(\frac{81\pi^2\nu}{16\rho Q^2\omega^2} \right)^{1/3} R^{4/3} \quad (3)$$

Where, t = mean residence time (s). The residence time for 'n' number of cloths was calculated by multiplying the residence time for a single cloth with the cloth number (n).

2.5 Design of Experiments (DoE)

The effect of different factors such as spinning speed, cloth number and cloth size on reaction conversion and rate was analysed using the Design of Experiments (DoE) approach. Minitab statistical software was used to create a two-level full factorial design and the experiments were performed in random order. The response as a function of conversion and rate were analysed using an Effects and a Pareto chart plot. The standardised effect of the factors were plotted according to their order of significance in the Pareto chart and the dotted line indicating a significance of 5%.

3. Results and discussion

3.1 Effect of increasing cloth size and cloth number on the enzymatic hydrolysis of tributyrin in the SMDR

Design of Experiment

The results from DoE are summarised in Table 1 and discussed with respect to the reaction rate as the response as it incorporates more data points during the course of the reaction. The hydrolysis reaction occurs in two steps. The first, faster stage is the hydrolysis of the first ester bond in the water phase and available readily for the lipase. The reaction rate decreases thereafter due to the steric hindrance caused by the remaining ester bonds, and are thus not easily accessible for the lipase. At around 50% conversion, the reaction solution turns from a cloudy emulsion to a clear solution [15, 16]. As most of the reaction occurs in the first 60 minutes, the initial reaction rate has been used to characterise the effect of operating parameters on reactor scale-up.

As can be seen from Fig. 2 (a) and (b), the normalised effects plot and the Pareto plots for reaction rate as the response indicates that cloth number, cloth size and RPM (in this order) have a significant effect on the conversion. In the effects plot, the factors that are farthest away from the origin have a greater significance on the response. The Pareto chart is a plot of factors in the order of significance of their standardised effects (from the effects plot) on the initial reaction rate with the dotted line indicating a significance of 5%. Increasing cloth number and cloth size individually has a greater effect on the reaction rate compared to increasing both variables at the same time (explained in the following section). Spinning speed on its own also has a positive effect on the reaction rate, but less significant compared to cloth size and number. This is because the enzymatic reaction is operated at a spinning speed which corresponds to that below the critical shear stress to

188 minimise enzyme deactivation [9, 12]. Overall, the results from the DoE studies indicates that reaction scale-
 189 up in the SMDR primarily depends on either the cloth size and cloth number and increasing multiple factors
 190 at the same time does not have a significant effect on the reaction rate for a given substrate concentration.

191 Table 1. Results from the Design of Experiments studies for tributyrin hydrolysis

Entry	Spinning Speed (RPM)	Cloth diameter (m)	Cloth number	Initial reaction rate (mM min ⁻¹)	Conversion (%)
1	450	0.5	1	5.03	87
2	250	0.2	1	2.46	67
3	450	0.2	1	3.56	75
4	250	0.5	1	4.10	83
5	250	0.5	3	5.10	85
6	450	0.2	3	4.96	82
7	450	0.5	3	5.82	91
8	250	0.2	3	4.64	79

192

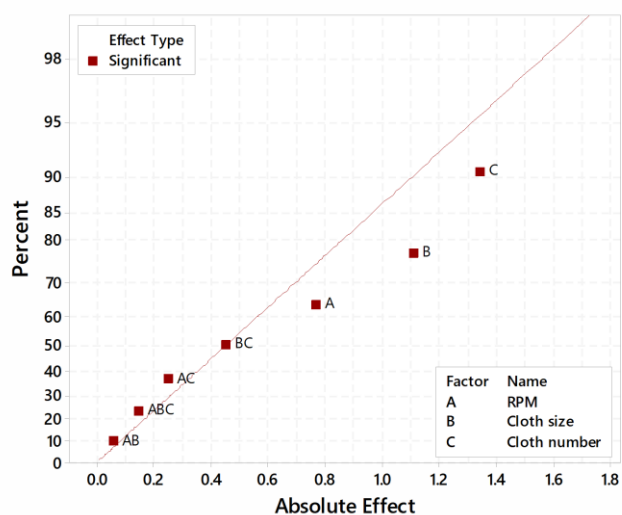

193

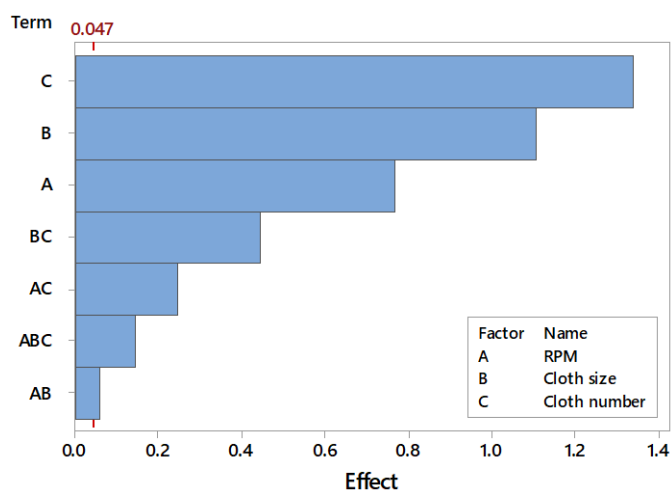

194

195

Figure 4: DoE plots with reaction rate as response: (a) Effects plot, (b) Pareto chart plot

196 **Effect of cloth size:** An increase in the cloth size results in an increase in the overall surface area of the cloth
197 and also the catalyst loading for a given substrate concentration. Fig. 3(a) shows an increase in the reaction
198 conversion from 67.6% to 87.7% after 3 hours and fig 3(c) shows an increase in the reaction rate from 2.67mM
199 min^{-1} to 4.64 mM min^{-1} with an increase in the cloth size from 20 cm to 50 cm. Fig 3(b) shows that an increase
200 in the cloth radius results in a lower mean film thickness due to increasing average surface shear (equation 2).
201 This results in rapid mixing within the thin film of liquid over the cloth surface resulting in lower mass transfer
202 resistance and better contact with the substrate and the catalyst. Hence, the mean film thickness is an additional
203 factor that results in higher reaction rates with an increase in the cloth size.

204 **Numbering-up of cloths:** Figure 3 (c) shows the effect of numbering-up catalyst cloth on reaction rate and
205 the reaction rate increased with addition of cloths across the various cloth sizes. The reaction rate for three 20
206 cm cloths (4.64 mM min^{-1}) is comparable to the reaction rate obtained using one 50 cm cloth (4.38 mM min^{-1}).
207 Addition of cloths results in an increase in the total volume of the cloth stack and hence the enzyme loading
208 (supplementary information A). Visual studies have shown that the centrifugal and gravitation forces promote
209 complete wettability of the cloth stack in both tangential and downward direction facilitating reaction both on
210 and within the catalyst cloth surface [7]. The increase in the reaction rate for multiple 20 cm cloths is more
211 pronounced compared to multiple 30 cm and 50 cm cloths at a lower substrate concentration. This is because,
212 the catalyst: substrate ratio is high even with a single large cloth and the reaction goes to completion at a faster
213 rate and no further increase in the reaction rate is observed with the addition of lipase cloths. In difference,
214 when the concentration of tributyrin was increased to 99 mM (i.e. decreasing the catalyst: substrate ratio) a
215 significant positive effect can be observed for the 50cm catalyst cloth. The rate increased from 3.8 mM min^{-1}
216 (one cloth) to 6.96 mM min^{-1} (three cloths). At this higher substrate concentration, the reaction rate is limited
217 by the number of active sites present on the cloth. Hence, further showing that the reaction rate, and the
218 productivity can be tailored by increasing both the cloth size and cloth number at higher substrate
219 concentration.

220 Fig. 3(d) shows the increase in mean residence time with increasing cloth size and number. The mean
221 residence time for a 50 cm cloth is nearly twice that of three 20 cm cloths. Addition of cloths in the SMDR
222 leads to an increased resistance to the flow by the cloth fibre mesh creating multiple flow channels resulting

223 in a well-mixed reactor compared to a conventional spinning disc reactor which follows plug flow behaviour
224 [17].

225 These results indicate that the scale-up in the SMDR can be achieved by either increasing the cloth size or
226 cloth number. The increasing reaction rate with increasing cloth size is primarily due to the increase in catalyst
227 loading and the mean residence time. A further increase in the reaction rate can be achieved by numbering-up
228 the catalyst cloths of increasing diameters facilitating a tuneable operation of the SMDR.

229

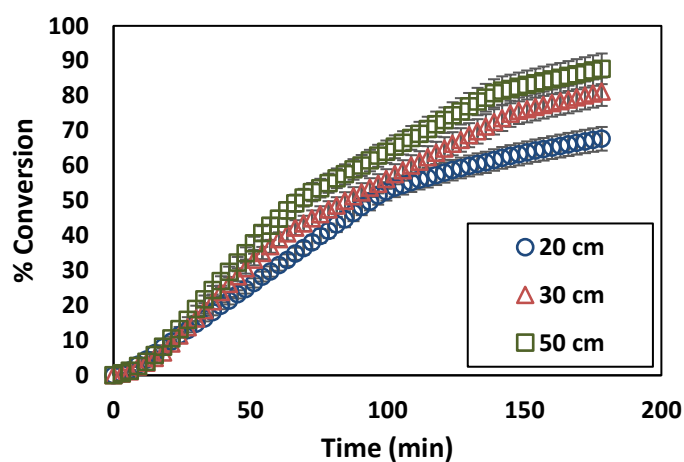

230

231

(a)

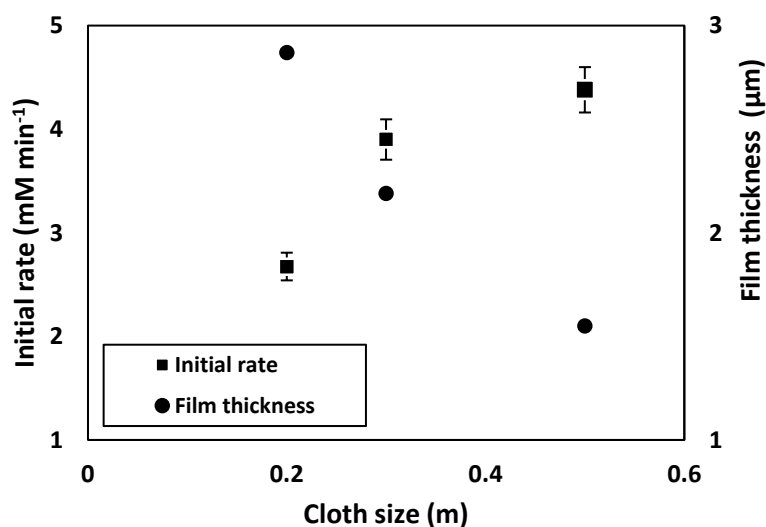

232

233

(b)

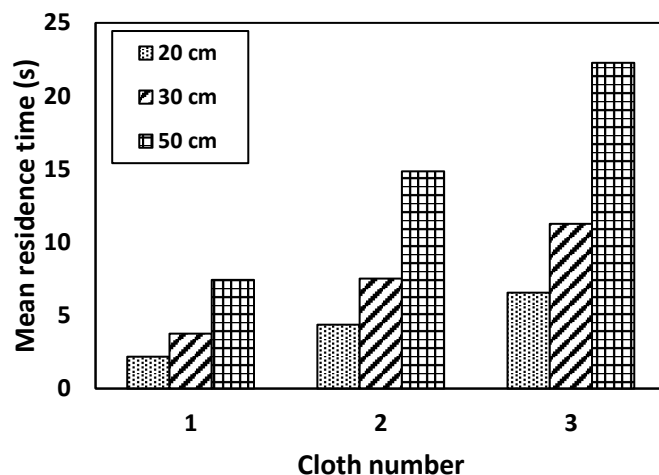
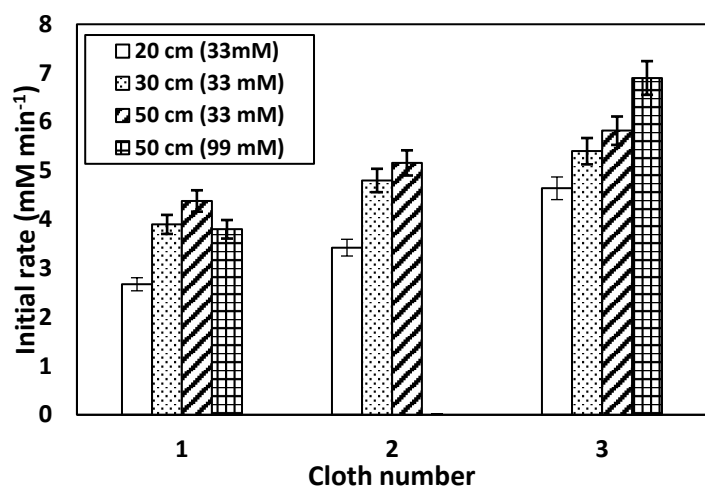

235

(c)

(d)

236

237

238

239

240

241

242

243

244

245

246

247

248

249

250

251

Figure 5: (a) Effect of cloth size (single cloth) on reaction conversion as a function of time, (b) Effect of cloth size on initial reaction rate (substrate concentration 33 mM), (c) Comparison of initial reaction rates for different cloth size and cloth numbers. The reactions were carried out at spinning speed of 350 RPM and flowrate of 3 ml s⁻¹ and (d) Mean residence time as a function of increasing cloth size and cloth number

3.2 Effect of changing cloth size and cloth number on nitroaldol condensation reaction in the SMDR

To establish the proof of concept for scale-up of organic reactions in the SMDR, nitroaldol condensation reaction was carried out by altering the copper catalyst loading through increasing cloth size and cloth number.

Effect of cloth size: Fig 4(a) shows that the reaction conversion increased with increase in cloth size and the reaction rate increased from 0.018 mmol min⁻¹ (20 cm cloth) to 0.033 mmol min⁻¹ (50 cm cloth). The overall reaction rate co-efficient (k_{ovl}) increased from 5.86×10^{-6} m³/m²_{cloth} s⁻¹ (20 cm cloth) to 1.40×10^{-5} m³/m²_{cloth} s⁻¹ (50 cm cloth) indicating an increase in mass transfer from liquid to the cloth surface with increase in cloth surface area. Further, the average surface shear with increasing cloth size and rotation speed for the organic solvent system was nearly 1.5 times less compared to the aqueous system (supplementary information B). The surface shear on the cloth surface is dependent on the fluid properties of the reaction medium, which varies according to the solvent used and hence the increase in reaction rate for the solvent system is less profound compared to the aqueous system. Hence, the increase in rate and productivity for organic reactions is mainly

252 due to the increase in the amount of catalyst immobilised with increasing cloth surface area and a longer
253 residence time on the cloth surface. The overall reaction rate co-efficient (k_{ovl})

254 **Effect of numbering-up cloths:** Similar to tributyrin hydrolysis, addition of multiple 20 cm cloths (up to 3
255 cloths) resulted in a reaction rate similar to that obtained using a 50 cm cloth. The reaction scale-up through
256 increasing cloth size and cloth number demonstrated a compounding effect on the reaction rate and the
257 maximum reaction rate of $0.043 \text{ mmol min}^{-1}$ was obtained for three 50 cm cloths. Although the liquid feed
258 had penetrated through the entire cloth stack, a compounding effect in the reaction was not observed as seen
259 for the aqueous system at a higher substrate concentration. This is due to a lower volume of liquid entrapped
260 in the cloth stack (due to lower wettability of woollen cloth by ethanol compared to water) and hence lesser
261 contact with the feed stream and the catalyst.

262 Overall, the results indicate that the SMDR can be scaled for organic reactions either by increasing the cloth
263 size or cloth number as demonstrated for the above reaction. To the best of the authors' knowledge, this is the
264 first report on the scale-up of nitroaldol condensation reaction in the SMDR.

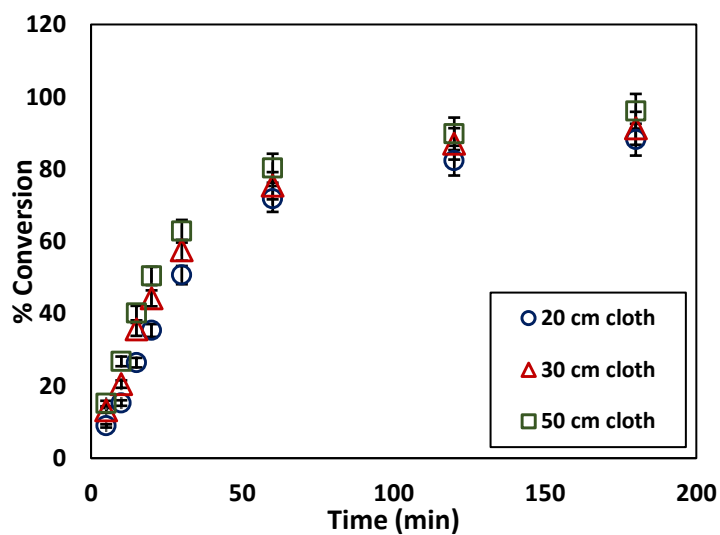

265

(a)

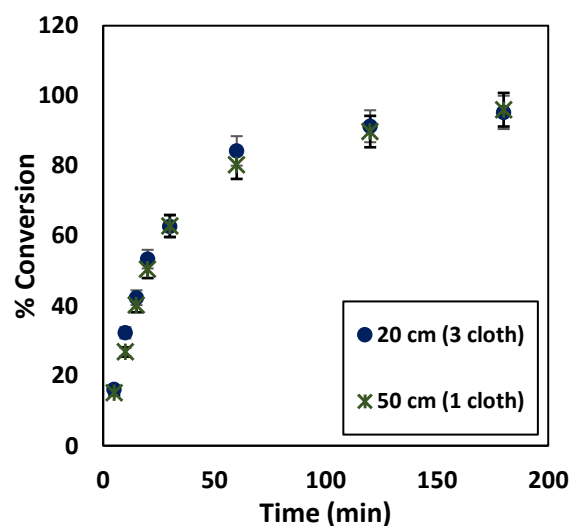

266

(b)

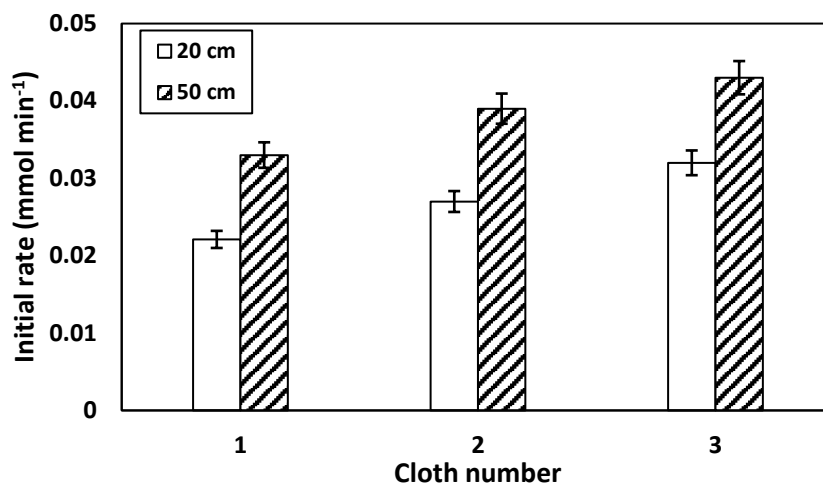

(c)

Figure 6: Nitroaldol condensation reaction (a) Effect of cloth size on reaction conversion as a function of time, (b) comparison between reaction conversion for three 20 cm cloths and a 50 cm cloth, (c) reaction rate comparison for scale-up by increasing cloth diameter vs increasing cloth number. All reactions were carried out at a spinning speed of 350 RPM and flowrate of 3 ml s⁻¹.

4. Conclusion

In this study, scale-up of SMDR was investigated using two routes: (i) increasing cloth size and (ii) addition of multiple cloths. The reactor performance was evaluated for the hydrolysis of tributyrin and nitroaldol condensation reactions as the reactions were previously optimised in the SMDR. The reactions were carried out in a newly designed reactor allowing for various disc diameters and reduced spin-up zone on the disc surface. A two level, full factorial DoE study was carried out to understand the effect of spinning speed, cloth size and cloth number on the reaction rate. Results from the DoE studies indicated that increasing either cloth size or cloth number individually had a greater effect on the reaction rate for a given substrate concentration. Further, increasing the cloth size resulted in an increase in conversion and reaction rate as a result of increased surface area of the catalyst cloth. The reaction rate achieved with a single 50 cm cloth (4.38 mM min⁻¹) was comparable to that of three 20 cm cloths (4.64 mM min⁻¹) for a tributyrin substrate concentration of 33 mM. Addition of multiple cloths of increasing cloth size also showed an increase in the reaction rate and the reaction rate increased by 36% at a substrate concentration of 99mM for three 50 cm cloths. The study was extended to nitroaldol condensation reaction catalysed by copper immobilised on wool. Similar to the previous case, an increase in reaction conversion and rate was observed with increase in cloth size and cloth number and addition

of three 20 cm catalyst cloths yielded similar rate ($0.032 \text{ mmol min}^{-1}$) to that of a single 50 cm cloth ($0.033 \text{ mmol min}^{-1}$). Overall, it can be concluded that the reaction scale-up in the SMDR can be achieved by increasing the cloth size and the cloth number for both aqueous and organic reaction systems, making it a flexible reactor design for reaction intensification. Future work will aim to examine higher reaction throughput for scale-up of organic reactions.

Acknowledgement

The authors thank the University of Bath for the PhD scholarship of PS and the Department of Chemical Engineering for technical support.

References

1. Vlachos, D.G. and S. Caratzoulas, *The roles of catalysis and reaction engineering in overcoming the energy and the environment crisis*. Chemical Engineering Science, 2010. **65**(1): p. 18-29.
2. Ramshaw, C., *Higee' distillation-an example of process intensification*. Chemical Engineer, 1983: p. 13-14.
3. Oxley, P., C. Brechtelsbauer, F. Ricard, N. Lewis, and C. Ramshaw, *Evaluation of spinning disk reactor technology for the manufacture of pharmaceuticals*. Industrial & engineering chemistry research, 2000. **39**(7): p. 2175-2182.
4. Pask, S.D., O. Nuyken, and Z. Cai, *The spinning disk reactor: an example of a process intensification technology for polymers and particles*. Polymer Chemistry, 2012. **3**(10): p. 2698-2707.
5. De Beer, M., J. Keurentjes, J. Schouten, and J. Van der Schaaf, *Engineering model for single-phase flow in a multi-stage rotor-stator spinning disc reactor*. Chemical Engineering Journal, 2014. **242**: p. 53-61.
6. Meeuwse, M., J. van der Schaaf, and J.C. Schouten, *Multistage rotor-stator spinning disc reactor*. AIChE Journal, 2012. **58**(1): p. 247-255.
7. Feng, X., D.A. Patterson, M. Balaban, and E.A.C. Emanuelsson, *Increasing reaction rate and conversion in the spinning cloth disc reactor: Investigating the effect of using multiple enzyme immobilized cloths*. Chemical Engineering Journal, 2014. **255**: p. 356-364.
8. McNeil, S.J., M.R. Sunderland, and S.J. Leighs, *The utilisation of wool as a catalyst and as a support for catalysts*. Applied Catalysis A: General, 2017. **541**: p. 120-140.
9. Feng, X., D.A. Patterson, M. Balaban, G. Fauconnier, and E.A.C. Emanuelsson, *The spinning cloth disc reactor for immobilized enzymes: A new process intensification technology for enzymatic reactions*. Chemical engineering journal, 2013. **221**: p. 407-417.
10. Feng, X., D.A. Patterson, M. Balaban, and E.A.C. Emanuelsson, *Enabling the utilization of wool as an enzyme support: enhancing the activity and stability of lipase immobilized onto woolen cloth*. Colloids and Surfaces B: Biointerfaces, 2013. **102**: p. 526-533.
11. Shivaprasad, P., M.D. Jones, D.A. Patterson, and E.A.C. Emanuelsson, *Process intensification of catalysed henry reaction using copper-wool catalyst in a spinning mesh disc reactor*. Chemical Engineering and Processing: Process Intensification, 2017. **122**: p. 550-559.
12. Shivaprasad, P., M.D. Jones, D.A. Patterson, and E.A.C. Emanuelsson, *Kinetic resolution of 1-phenylethanol in the spinning mesh disc reactor: Investigating the reactor performance using immobilised lipase catalyst*. Chemical Engineering and Processing-Process Intensification, 2018.
13. Haas, M.J., D. Esposito, and D.J. Cichowicz, *A software package to streamline the titrimetric determination of lipase activity*. Journal of the American Oil Chemists' Society, 1995. **72**(11): p. 1405-1406.

- 330 14. Boodhoo, K.V., W.A. Dunk, M. Vicevic, R.J. Jachuck, V. Sage, D.J. Macquarrie, and J.H. Clark,
331 *Classical cationic polymerization of styrene in a spinning disc reactor using silica-supported BF₃*
332 *catalyst*. Journal of applied polymer science, 2006. **101**(1): p. 8-19.
- 333 15. Salentinig, S., L. Sagalowicz, M.E. Leser, C. Tedeschi, and O. Glatter, *Transitions in the internal*
334 *structure of lipid droplets during fat digestion*. Soft Matter, 2011. **7**(2): p. 650-661.
- 335 16. Jurado, E., F. Camacho, G. Luzón, M. Fernández-Serrano, and M. García-Román, *Kinetic model for*
336 *the enzymatic hydrolysis of tributyrin in O/W emulsions*. Chemical Engineering Science, 2006. **61**(15):
337 p. 5010-5020.
- 338 17. Feng, X., D.A. Patterson, M. Balaban, and E.A.C. Emanuelsson, *Characterization of liquid flow in the*
339 *spinning cloth disc reactor: Residence time distribution, visual study and modeling*. Chemical
340 Engineering Journal, 2014. **235**: p. 356-367.