

2013

## Respirable and inhalable dust measurement and control efficiency determination in high production longwalls

Brian Plush  
*University of Wollongong*

Follow this and additional works at: <https://ro.uow.edu.au/theses>

### University of Wollongong

#### Copyright Warning

You may print or download ONE copy of this document for the purpose of your own research or study. The University does not authorise you to copy, communicate or otherwise make available electronically to any other person any copyright material contained on this site.

You are reminded of the following: This work is copyright. Apart from any use permitted under the Copyright Act 1968, no part of this work may be reproduced by any process, nor may any other exclusive right be exercised, without the permission of the author. Copyright owners are entitled to take legal action against persons who infringe their copyright. A reproduction of material that is protected by copyright may be a copyright infringement. A court may impose penalties and award damages in relation to offences and infringements relating to copyright material.

Higher penalties may apply, and higher damages may be awarded, for offences and infringements involving the conversion of material into digital or electronic form.

Unless otherwise indicated, the views expressed in this thesis are those of the author and do not necessarily represent the views of the University of Wollongong.

### Recommended Citation

Plush, Brian, Respirable and inhalable dust measurement and control efficiency determination in high production longwalls, Doctor of Philosophy thesis, School of Civil, Mining and Environmental Engineering, University of Wollongong, 2013. <https://ro.uow.edu.au/theses/3878>

Research Online is the open access institutional repository for the University of Wollongong. For further information contact the UOW Library: [research-pubs@uow.edu.au](mailto:research-pubs@uow.edu.au)

---

**RESPIRABLE AND INHALABLE  
DUST MEASUREMENT AND  
CONTROL EFFICIENCY  
DETERMINATION IN HIGH  
PRODUCTION LONGWALLS**

A Thesis Submitted in Fulfilment of the Requirements  
for the Degree of

**DOCTOR OF PHILOSOPHY**

From

**UNIVERSITY OF  
WOLLONGONG**



by

**BRIAN WILLIAM PLUSH**

School of Civil, Mining and Environmental Engineering

March 2013



*'Please, madam. I'm trying to determine which is less expensive . . . funerals or safety standards.'*

---

## **AFFIRMATION**

I, Brian William Plush, declare that this thesis, submitted in fulfilment of the requirements for the award of Doctor of Philosophy, in the Department of Civil, Mining and Environmental Engineering, University of Wollongong, is wholly my own work unless otherwise referenced or acknowledged. The document has not been submitted for qualifications at any other academic institution.

Brian Plush

---

The following publications are the result of this thesis project:

1. Ren, T.X., Karekal, S., Cooper, G., Wang, Z., and Plush, B. (2013). Design And Field Trials Of Water-Mist Based Venturi Systems For Dust Mitigation On Longwall Faces 13th Underground Coal Operators' Conference (pp. 182-190). Australia: University of Wollongong Printery. (Publication ID=371624)
2. Plush, B., Ren, T., Cram, K. & Aziz, N. (2011). Dust monitoring and control efficiency measurement in longwall mining. 11th Underground Coal Operators' Conference (pp. 231-238). Australia: University of Wollongong Printery. (Publication ID=35671)
3. Ren, T. X., Plush, B. & Aziz, N. (2011). Dust controls and monitoring practices on Australian longwalls. 1st International Symposium on Mine Safety Science and Engineering, ISMSSE 2011 (pp. 1182-1194). Elsevier BV. (Publication ID=50701)
4. Plush, B. Ren, T. Aziz, N. (2012). A Critical Evaluation of Dust Sampling Methodologies In Longwall Mining In Australia And The USA. 12th Underground Coal Operators' Conference (pp. 193-201).
5. Ren T., Balusu R and Plush B., 2007, Dust control technology development for longwall faces– Shearer Scrubber Development, ACARP Project C14036, CSIRO Exploration and Mining Report P2007/362.
6. Ren T., Balusu R and Plush B., 2009, Dust Control Technology for Longwall Faces – Shearer Scrubber Development and Field Trials, ACARP Project C14036, CSIRO Exploration and Mining Report P2009/1178.
7. Ren T., Plush B. and Rao Balusu, Development of a New Shearer Scrubber System for Dust Control, Queensland Mining Industry Health and Safety Conference 2009

---

## ACKNOWLEDGEMENTS

I would like to acknowledge and thank my thesis supervisor Dr Ting Ren, Senior Lecturer, Department of Civil, Mining and Environmental Engineering, University of Wollongong for his expertise, generous support, guidance and friendship throughout this study.

I would also like to thank my second supervisor Professor Naj Aziz for his expertise, guidance and complete support throughout this study.

I wish to acknowledge and thank my wife Ann Plush for her unconditional support during the considerable time involved in completing this PhD study.

Further, I need to acknowledge and thank the following people and organisations who have provided assistance and support to this study:

- Mr Ken Risk and Mr Kurt Weingardt from Peabody's Metropolitan Mine;
- Mr Alex Sakun and Mr Tim Smith From Appin West Mine;
- Mr Ben Mackay from Moranbah North Coal Mine;
- Mr Michael Bailey, Mr Darren Borg and Mr Kelvin Schiefelbein from Austar Coal Mine
- Longwall and engineering staff at Vale's Integra Mine

Finally, I would like to acknowledge and thank Mr Brian Maggs for his expert help with the editing of this PhD thesis.

---

## ABSTRACT

Dust sampling in Australian coal mines is carried out with cyclone separation and collection of the sized particles for weighing, generally over the period of a full shift to measure personal exposure levels to airborne contaminants of employees. This testing methodology is described in AS2985 for determination of respirable dust and AS3640 for inhalable dust. These testing methodologies give an accurate figure for the personal dust exposure levels of employees for the period sampled, but cannot be related to any specific longwall operational sources of dust generation or to the efficiency of dust mitigation controls installed at those sources.

Fugitive dust on longwalls has always been an issue of concern for production, safety and the health of workers in the underground coal mining industry both in Australia and globally. Longwall personnel can be exposed to harmful respirable and inhalable dust from multiple dust generation sources including, but not limited to: intake entry, belt entry, stageloader/crusher, shearer, and chock advance. With the increase in production created from the advancement in longwall equipment, dust loads have also increased and this has resulted in an increase in exposure levels to personnel.

The main objective of this thesis was to develop a new dust monitoring methodology to quantify and document both respirable and inhalable dust magnitudes generated from different sources, and assess the efficiency of installed controls for the mitigation of produced dust, using gravimetric sampling as per statutory requirements. The resulting Dust Mitigation Efficiency (DME) model has been developed to identify respirable and inhalable dust loads at independent sources of dust generation on longwall faces and quantify the efficiency of installed controls for the mitigation of this produced dust.

The DME model will shed some fundamental and scientific insights into an area of genuine concern to the mining community and will enhance the current practices of statutory dust monitoring. It will also offer a significant benefit to the coal mining industry by providing a benchmark or signature dust load monitoring procedure along with the implementation of quantified best mitigation practices.

---

The DME model has been used to identify respirable and inhalable dust loads at independent sources of dust generation on longwall faces and quantify the efficiency of installed controls for the mitigation of this produced dust. The data collected from each of the sampled mines during the field trials has been used to create a benchmark or signature for each longwall of those mines in relation to dust loads from different sources of generation to ensure maximum efficiency in removing respirable and inhalable dusts.

The DME model has also successfully identified the most efficient installed engineering controls operating at individual sources of respirable and inhalable dust generation on operating longwalls in Australia. The use of the DME model as opposed to the statutory measurement process will allow mine operators to establish a dust mitigation regime based on the measured best practice for installed engineering controls.

A total of 360 samples were taken for data analysis to quantify the robustness of the DME model and determination of the best practice engineering controls. Of these, 190 were respirable samples and the remaining 170 were inhalable samples. With the DME model, it is envisaged that a greater reduction in both respirable and inhalable dust can be achieved with best practice engineering, which will have a direct reduction in exposure levels to workers on the face and significantly reduce the risk of lung disease in employees.

The establishment of the DME model for respirable and inhalable dust load identification and control efficiency determination has shown to be a valuable and robust informational tool that will have a significant benefit to not only the underground coal industry, but all industries that are affected by airborne contaminants less than 10  $\mu\text{m}$  in size (PM10). The ability to understand the actual dust production, coupled with the quantification of performance of installed engineering controls for dust mitigation, will give all operators of dust producing activities a valuable tool to better control their airborne contaminants.

It is suggested that further studies be undertaken to include;



- 
- the use of Personal Dust Monitors (PDM's) for data collection with the DME model used to calculate efficiencies;
  - use of the DME model to better understand respirable and inhalable dust production and control in development panels and bord and pillar mining;
  - medical research be conducted to understand how much respirable and inhalable dust is actually required to be ingested to create medical problems, and;
  - comprehensive research into the accuracy of current exposure level limits and their suitability to the continually increasing production in the global mining industry.

By better understanding respirable and inhalable dust production and application of a best management practice to mitigate airborne contaminants, a significantly healthier workplace and environment will be achieved.

---

## TABLE OF CONTENTS

<b>AFFIRMATION</b> .....	<b>II</b>
<b>ACKNOWLEDGEMENTS</b> .....	<b>IV</b>
<b>ABSTRACT</b> .....	<b>V</b>
<b>TABLE OF CONTENTS</b> .....	<b>VIII</b>
<b>LIST OF TABLES</b> .....	<b>XVI</b>
<b>LIST OF FIGURES</b> .....	<b>XVIII</b>
<b>LIST OF EQUATIONS</b> .....	<b>XXV</b>
<b>GLOSSARY OF TERMS</b> .....	<b>XXVI</b>
<b>CHAPTER ONE – GENERAL INTRODUCTION</b> .....	<b>1</b>
1.1 GENERAL .....	1
1.2 STATEMENT OF THE PROBLEM .....	4
1.3 AIMS AND OBJECTIVES .....	6
1.4 THESIS OUTLINE .....	7
<b>CHAPTER TWO - DUST: DEFINITIONS, DEPOSITION AND     PHYSIOLOGICAL EFFECTS</b> .....	<b>9</b>
2.1 DUST DEFINITION .....	9
2.2 DUST FRACTIONS.....	14
2.2.1 <i>Inhalable Dust</i> .....	15
2.2.2 <i>Respirable Dust</i> .....	15
2.3 PARTICLE DEPOSITION IN THE HUMAN AIRWAY TRACT .....	16
2.3.1 <i>Sedimentation</i> .....	19
2.3.1.1 Brownian Motion .....	20
2.3.2 <i>Inertial Impaction</i> .....	21
2.3.3 <i>Diffusion</i> .....	23
2.3.4 <i>Interception</i> .....	24
2.3.5 <i>Electrostatic Deposition</i> .....	25
2.4 PHYSIOLOGICAL EFFECTS OF DUST ON THE HUMAN BODY .....	25
2.4.1 <i>Dust Classifications</i> .....	28
2.4.1.1 Mucociliary Escalator.....	28
2.4.1.2 Lymphatic System .....	29
2.4.1.3 Toxic Dusts.....	29
2.4.1.4 Carcinogenic Dusts .....	29
2.4.1.5 Fibrogenic Dusts.....	30
2.4.1.6 Explosive Dusts.....	30

2.4.1.7	Nuisance Dusts.....	30
2.5	TYPES OF LUNG DISEASE.....	30
2.5.1	<i>Pneumoconiosis</i> .....	31
2.5.2	<i>Silicosis</i> .....	33
2.5.2.1	Simple Silicosis.....	34
2.5.2.2	Complicated Silicosis.....	36
2.5.2.3	Accelerated Silicosis.....	37
2.5.2.4	Acute Silicosis.....	38
2.5.3	<i>Silica and Lung Cancer</i> .....	38
2.6	SUMMARY.....	39

**CHAPTER THREE - THE PRODUCTION OF RESPIRABLE AND  
INHALABLE DUST ..... 40**

3.1	DUST PRODUCTION IN LONGWALL MINING.....	40
3.1.1	<i>Sources of Longwall Dust Generation</i> .....	41
3.1.1.1	The Last Open Cut-Through (LOC).....	43
3.1.1.2	The Outbye Belt Road.....	44
3.1.1.3	BSL Discharge.....	44
3.1.1.4	Crusher Inlet.....	45
3.1.1.5	Shearer Generated Dust.....	46
3.1.1.6	Chock Generated Dust.....	48
3.1.1.7	Goaf Generated Dust.....	49
3.2	SUMMARY.....	49

**CHAPTER FOUR - DUST CONTROLS ON AUSTRALIAN LONGWALLS.. 50**

4.1	INTRODUCTION.....	50
4.2	DUST MITIGATION CONTROLS USED ON AUSTRALIAN LONGWALLS.....	51
4.2.1	<i>Controlling Dust on Intake Roadways</i> .....	51
4.2.2	<i>Controlling Dust from the Outbye Belt</i> .....	52
4.2.3	<i>Crusher and BSL Dust Control</i> .....	53
4.2.4	<i>Controlling Shearer Dust</i> .....	58
4.2.5	<i>Controlling Chock Dust</i> .....	63
4.3	SUMMARY.....	66

**CHAPTER FIVE - CURRENT AUSTRALIAN AND USA DUST  
MONITORING PRACTICES..... 67**

5.1	INTRODUCTION.....	67
5.2	CURRENT AUSTRALIAN DUST MONITORING PRACTICES.....	70
5.2.1	<i>Coal Services NSW Statutory Dust Monitoring</i> .....	71
5.2.2	<i>Simtars QLD Statutory Dust Monitoring</i> .....	77
5.3	DISCUSSION.....	79
5.4	CURRENT USA DUST MONITORING PRACTICES.....	80
5.5	LIMITATIONS OF CURRENT STATUTORY TESTING REGIMES.....	82
5.5.1	<i>Australian Limitations</i> .....	82
5.5.2	<i>US Limitations</i> .....	83
5.6	SUMMARY.....	85

**CHAPTER SIX - DUST MITIGATION EFFICIENCY (DME) MODEL ..... 87**

6.1	INTRODUCTION.....	87
6.2	TESTING METHODOLOGY.....	90

6.2.1	<i>Identify and Record Engineering Controls</i> .....	90
6.2.2	<i>Determine Pump and Head Placement</i> .....	91
6.2.2.1	Pump and Head Placement in LOC .....	92
6.2.2.2	Pump and Monitor Placement in Belt Road .....	93
6.2.2.3	Pump and Head Placement for BSL Discharge.....	94
6.2.2.4	Pump and Head Placement for Crusher Intake .....	95
6.2.2.5	Pump and Head Placement for Tailgate Chock.....	96
6.2.3	<i>Establish Benchmark Dust Load Production</i> .....	96
6.2.4	<i>Quantify Control Dust Mitigation Efficiency</i> .....	96
6.3	RESEARCH DESIGN .....	96
6.3.1	<i>Applied Research for Data Collection</i> .....	96
6.4	PREPARATION PROCESS FOR DATA COLLECTION .....	99
6.4.1	<i>Prepare Identification Labels</i> .....	99
6.4.2	<i>Preparing Petri Dishes for Filter Identification</i> .....	100
6.4.3	<i>Pre Weighing Filter Process</i> .....	102
6.4.4	<i>Sampling Head Loading Process</i> .....	106
6.5	PUMP CALIBRATION PROCESS.....	108
6.5.1	<i>Inhalable Pump Calibration Process</i> .....	108
6.5.2	<i>Respirable Dust Pump Calibration Process</i> .....	108
6.6	POST-WEIGH PROCEDURE.....	108
6.7	CALCULATING DUST MITIGATION EFFICIENCY .....	110
6.7.1	<i>Calculating Exposure Levels</i> .....	110
6.7.2	<i>Calculating DME</i> .....	112
6.7.3	<i>Example of DME Calculation</i> .....	113
6.7.4	<i>Respirable DME at Last Open Cut-Through</i> .....	114
6.7.5	<i>Respirable DME at Belt Road</i> .....	115
6.7.6	<i>Respirable DME at BSL Discharge</i> .....	116
6.7.7	<i>Respirable DME at the Maingate</i> .....	117
6.7.8	<i>Respirable DME at the Tailgate</i> .....	118
6.7.9	<i>Inhalable DME at Last Open Cut-through (LOC)</i> .....	119
6.7.10	<i>Inhalable DME at Belt Road</i> .....	120
6.7.11	<i>Inhalable DME at BSL Discharge</i> .....	121
6.7.12	<i>Inhalable DME at the Maingate</i> .....	122
6.7.13	<i>Inhalable DME at the Tailgate</i> .....	123
6.8	INSTRUMENTATION FOR DATA COLLECTION .....	124
6.8.1	<i>AS2985 Respirable Dust Sampling</i> .....	124
6.8.2	<i>AS3640 Inhalable Dust Sampler</i> .....	126
6.9	RISK ASSESSMENTS .....	128
6.10	SUMMARY .....	132

## **CHAPTER SEVEN - FIELD TRIALS IN AUSTRALIAN LONGWALLS .....133**

7.1	FIELD STUDY MINE A.....	133
7.1.1	<i>Operational Parameters of Mine A</i> .....	134
7.1.2	<i>Pump and Head Location Mine A</i> .....	135
7.1.2.1	Pump and Head Location in Last Open Cut-through.....	135
7.1.2.2	Pump and Head Location in Belt Road.....	136
7.1.2.3	Pump and Head Location at BSL Discharge .....	137
7.1.2.4	Pump and Head Location for Shearer Dust .....	138
7.1.2.5	Pump and Head Location for Crusher .....	139
7.1.2.6	Pump and Head Location for Crusher and BSL .....	140
7.1.2.7	Pump and Head Location for Chock Dust.....	141
7.1.2.8	Pump and Head Location for Total Dust .....	142
7.1.3	<i>Mine A Installed Engineering Controls</i> .....	143
7.1.3.1	Installed Controls in the BSL Discharge.....	144
7.1.3.2	Installed Controls in the Crusher and BSL .....	146
7.1.3.3	BSL Scrubber .....	149
7.1.3.4	Shearer Dust Controls.....	150

7.1.3.5	Other Dust Controls.....	152
7.2	FIELD STUDY MINE B.....	153
7.2.1	<i>Operational Parameters of Mine B</i> .....	153
7.2.2	<i>Pump and Head Location Mine B</i> .....	155
7.2.2.1	Pump and Head Location in Last Open Cut-through.....	155
7.2.2.2	Pump and Head Location in Belt Road.....	156
7.2.2.3	Pump and Head Location at BSL Discharge.....	157
7.2.2.4	Pump and Head Location for Crusher Dust.....	158
7.2.2.5	Pump and Head Location for Shearer Dust.....	159
7.2.2.6	Pump and Head Location for Chock Dust.....	160
7.2.2.7	Pump and Head Location for Total Dust.....	161
7.2.3	<i>Mine B Installed Engineering Controls</i> .....	162
7.2.3.1	Installed Controls in the BSL Discharge.....	163
7.2.3.2	Installed Controls in the Crusher and BSL.....	165
7.2.3.3	BSL Scrubber.....	170
7.2.3.4	Shearer Dust Controls.....	170
7.2.3.5	Other Dust Controls.....	172
7.3	FIELD STUDY MINE C.....	172
7.3.1	<i>Operational Parameters of Mine C</i> .....	173
7.3.2	<i>Pump and Head Location Mine C</i> .....	174
7.3.2.1	Pump and Head Location in Last Open Cut-through.....	175
7.3.2.2	Pump and Head Location in Belt Road.....	175
7.3.2.3	Pump and Head Location at BSL Discharge.....	176
7.3.2.4	Pump and Head Location for Crusher.....	177
7.3.2.5	Pump and Head Location for Total Dust.....	178
7.3.3	<i>Mine C Installed Engineering Controls</i> .....	179
7.3.3.1	Installed Controls in the BSL Discharge.....	180
7.3.3.2	Installed Controls in the Crusher and BSL.....	180
7.3.3.3	BSL Scrubber.....	181
7.3.3.4	Shearer Dust Controls.....	181
7.3.3.5	Other Dust Controls.....	183
7.4	FIELD STUDY MINE D.....	183
7.4.1	<i>Operational Parameters of Mine D</i> .....	183
7.4.2	<i>Pump and Head Location Mine D</i> .....	184
7.4.2.1	Pump and Head Location in Last Open Cut-through.....	185
7.4.2.2	Pump and Head Location in Belt Road.....	185
7.4.2.3	Pump and Head Location at BSL Discharge.....	185
7.4.2.4	Pump and Head Location for Crusher.....	185
7.4.2.5	Pump and Head Location for Total Dust.....	185
7.4.3	<i>Mine D Installed Engineering Controls</i> .....	186
7.4.3.1	Installed Controls in the BSL Discharge.....	187
7.4.3.2	Installed Controls in the Crusher and BSL.....	187
7.4.3.3	BSL Scrubber.....	187
7.4.3.4	Shearer Dust Controls.....	187
7.4.3.5	Other Dust Controls.....	189
7.5	FIELD STUDY MINE E.....	189
7.5.1	<i>Operational Parameters of Mine E</i> .....	189
7.5.2	<i>Pump and Head Location Mine E</i> .....	190
7.5.2.1	Pump and Head Location in Last Open Cut-through.....	191
7.5.2.2	Pump and Head Location in Belt Road.....	192
7.5.2.3	Pump and Head Location at BSL Discharge.....	193
7.5.2.4	Pump and Head Location for Crusher Dust.....	194
7.5.2.5	Pump and Head Location for Total Dust.....	195
7.5.3	<i>Mine E Installed Engineering Controls</i> .....	196
7.5.3.1	Installed Controls in the BSL Discharge.....	197
7.5.3.2	Installed Controls in the Crusher and BSL.....	199
7.5.3.3	Rear AFC Sprays.....	200
7.5.3.4	Shearer Dust Controls.....	201
7.5.3.5	Other Dust Controls.....	202
7.6	SUMMARY.....	204

---

## CHAPTER EIGHT - DATA ANALYSIS AND DISCUSSION.....205

8.1	INTRODUCTION .....	205
8.2	RESULTS MINE A TEST 1 .....	206
8.2.1	<i>Respirable and Inhalable Dust Raw Data</i> .....	206
8.2.2	<i>Respirable Dust Analysis</i> .....	207
8.2.3	<i>Respirable DME Discussion</i> .....	207
8.2.4	<i>Inhalable Dust Analysis</i> .....	208
8.2.5	<i>Inhalable DME Discussion</i> .....	209
8.2.6	<i>Respirable and Inhalable Average DME</i> .....	210
8.2.7	<i>Average DME Discussion</i> .....	211
8.2.8	<i>Summary</i> .....	211
8.3	RESULTS MINE B TEST 2 .....	211
8.3.1	<i>Respirable and Inhalable Dust Results from Coal Services</i> .....	212
8.3.2	<i>Respirable and Inhalable Dust Raw Data</i> .....	213
8.3.3	<i>Respirable Dust Analysis</i> .....	214
8.3.4	<i>Respirable DME Discussion</i> .....	215
8.3.5	<i>Inhalable Dust Analysis</i> .....	216
8.3.6	<i>Inhalable DME Discussion</i> .....	217
8.3.7	<i>Average DME Discussion</i> .....	217
8.3.8	<i>DME Conclusion</i> .....	217
8.4	RESULTS MINE C TEST 3 .....	218
8.4.1	<i>Respirable Dust Raw Data</i> .....	218
8.4.2	<i>Respirable Dust Analysis</i> .....	219
8.4.3	<i>Respirable DME Discussion</i> .....	220
8.4.4	<i>DME Conclusion</i> .....	220
8.5	RESULTS MINE C TEST 4 .....	220
8.5.1	<i>Respirable and Inhalable Dust Raw Data</i> .....	221
8.5.2	<i>Respirable Dust Analysis</i> .....	221
8.5.3	<i>Respirable Dust Discussion</i> .....	223
8.5.4	<i>Inhalable Dust Analysis</i> .....	223
8.5.5	<i>Inhalable Dust Discussion</i> .....	224
8.5.6	<i>Average DME Discussion</i> .....	224
8.5.7	<i>DME Conclusion</i> .....	225
8.6	RESULTS MINE C TEST 5 .....	225
8.6.1	<i>Respirable and Inhalable Dust Raw Data</i> .....	225
8.6.2	<i>Respirable Dust Analysis</i> .....	226
8.6.3	<i>Respirable Dust Discussion</i> .....	227
8.6.4	<i>Inhalable Dust Analysis</i> .....	228
8.6.5	<i>Inhalable Dust Discussion</i> .....	229
8.6.6	<i>Average DME Discussion</i> .....	229
8.6.7	<i>DME Conclusion</i> .....	229
8.7	RESULTS MINE B TEST 6 – VENTURI SPRAYS, TEST 1 .....	230
8.7.1	<i>Respirable and Inhalable Dust Raw Data</i> .....	231
8.7.2	<i>Respirable Dust Analysis</i> .....	231
8.7.3	<i>Respirable Dust Discussion</i> .....	233
8.7.4	<i>Inhalable Dust Analysis</i> .....	233
8.7.5	<i>Inhalable DME Discussion</i> .....	235
8.7.6	<i>DME Conclusion</i> .....	235
8.8	RESULTS MINE B TEST 7 – VENTURI SPRAYS, TEST 2 .....	235
8.8.1	<i>Respirable and Inhalable Dust Raw Data</i> .....	235
8.8.2	<i>Respirable Dust Analysis</i> .....	236
8.8.3	<i>Respirable Dust Discussion</i> .....	238
8.8.4	<i>Inhalable Dust Analysis</i> .....	238
8.8.5	<i>Inhalable DME Discussion</i> .....	239
8.8.6	<i>DME Conclusion</i> .....	239

8.9	RESULTS MINE D TEST 8 .....	239
8.9.1	<i>Respirable Dust Raw Data</i> .....	240
8.9.2	<i>Respirable Dust Production Test 1</i> .....	240
8.9.3	<i>Results Mine D Test 9</i> .....	241
8.9.4	<i>Respirable Dust Raw Data</i> .....	241
8.9.5	<i>Respirable Dust Production Test 2</i> .....	242
8.9.6	<i>Respirable Benchmark Dust Load Discussion</i> .....	242
8.9.7	<i>Average Respirable Dust Load Discussion</i> .....	244
8.10	RESULTS MINE B TEST 10 – VENTURI SPRAYS TEST 3 .....	245
8.10.1	<i>Respirable and Inhalable Dust Raw Data</i> .....	245
8.10.2	<i>Respirable Dust Analysis</i> .....	246
8.10.3	<i>Respirable DME Discussion</i> .....	247
8.10.4	<i>Inhalable Dust Analysis</i> .....	247
8.10.5	<i>Inhalable DME Discussion</i> .....	248
8.10.6	<i>DME Conclusion</i> .....	249
8.11	RESULTS MINE B TEST 11 – SURFACTANT TESTING .....	249
8.11.1	<i>Respirable and Inhalable Dust Raw Data</i> .....	249
8.11.2	<i>Respirable Dust Analysis</i> .....	250
8.11.3	<i>Respirable DME Discussion</i> .....	251
8.11.4	<i>Inhalable Dust Analysis</i> .....	251
8.11.5	<i>Inhalable DME Discussion</i> .....	252
8.11.6	<i>DME Conclusion</i> .....	253
8.12	RESULTS MINE E TEST 12 .....	253
8.12.1	<i>Respirable and Inhalable Dust Raw Data</i> .....	253
8.12.2	<i>Respirable Dust Analysis</i> .....	254
8.12.3	<i>Respirable DME Discussion</i> .....	255
8.12.4	<i>Inhalable Dust Analysis</i> .....	255
8.12.5	<i>Inhalable DME Discussion</i> .....	256
8.12.6	<i>Average DME Discussion</i> .....	257
8.12.7	<i>DME Conclusion</i> .....	257
8.13	RESULTS MINE C TEST 13 – COAL SERVICES SCRUBBER .....	257
8.13.1	<i>Respirable and Inhalable Dust Raw Data</i> .....	258
8.13.2	<i>Respirable Dust Analysis</i> .....	259
8.13.3	<i>Respirable DME Discussion</i> .....	260
8.13.4	<i>Inhalable Dust Analysis</i> .....	260
8.13.5	<i>Inhalable DME Discussion</i> .....	261
8.13.6	<i>DME Conclusion</i> .....	261
8.14	RESULTS MINE C TEST 14 .....	262
8.14.1	<i>Respirable and Inhalable Dust Raw Data</i> .....	262
8.14.2	<i>Respirable Dust Analysis</i> .....	263
8.14.3	<i>Respirable DME Discussion</i> .....	264
8.14.4	<i>Inhalable Dust Analysis</i> .....	264
8.14.5	<i>Inhalable DME Discussion</i> .....	265
8.14.6	<i>DME Conclusion</i> .....	265
8.14.7	<i>Mine C, Test 13 &amp; 14 DME Comparison to Test 4</i> .....	266
8.14.7.1	<i>Respirable and Inhalable DME Using Test 4 Benchmark</i> .....	266
8.14.7.2	<i>Respirable and Inhalable DME Discussion</i> .....	268
8.15	RESULTS MINE E TEST 15 .....	268
8.15.1	<i>Respirable and Inhalable Dust Raw Data</i> .....	269
8.15.2	<i>Respirable Dust Analysis</i> .....	270
8.15.3	<i>Respirable DME Discussion</i> .....	271
8.15.4	<i>Inhalable Dust Analysis</i> .....	271
8.15.5	<i>Inhalable DME Discussion</i> .....	272
8.15.6	<i>DME Discussion</i> .....	272
8.15.7	<i>DME Conclusion</i> .....	272
8.16	CUMULATIVE AVERAGE DME ANALYSIS .....	273
8.17	BENCHMARK RESPIRABLE DUST LOAD PRODUCTION .....	273

8.18	BENCHMARK RESPIRABLE DUST LOAD PRODUCTION COMPARATIVE ANALYSIS .....	276
8.18.1	<i>Mine A Respirable Dust Load Production Analysis .....</i>	277
8.18.2	<i>Mine A Respirable Benchmark Production Discussion .....</i>	278
8.18.3	<i>Mine B Respirable Dust Load Production Analysis .....</i>	279
8.18.4	<i>Mine B Respirable Benchmark Production Discussion .....</i>	280
8.18.5	<i>Mine C Respirable Dust Load Production Analysis.....</i>	281
8.18.6	<i>Mine C Respirable Benchmark Production Discussion .....</i>	282
8.18.7	<i>Mine E Respirable Dust Load Production Analysis.....</i>	283
8.18.8	<i>Mine E Respirable Benchmark Production Discussion .....</i>	284
8.19	BENCHMARK INHALABLE DUST LOAD PRODUCTION .....	284
8.20	BENCHMARK INHALABLE DUST LOAD PRODUCTION COMPARATIVE ANALYSIS .....	287
8.20.1	<i>Mine A Inhalable Dust Load Production Analysis .....</i>	288
8.20.2	<i>Mine A Inhalable Benchmark Production Discussion.....</i>	289
8.20.3	<i>Mine B Inhalable Dust Load Production Analysis .....</i>	290
8.20.4	<i>Mine B Inhalable Benchmark Production Discussion.....</i>	291
8.20.5	<i>Mine C Inhalable Dust Load Production Analysis .....</i>	292
8.20.6	<i>Mine C Inhalable Benchmark Production Discussion.....</i>	293
8.20.7	<i>Mine E Inhalable Dust Load Production Analysis .....</i>	294
8.20.8	<i>Mine E Inhalable Benchmark Production Discussion .....</i>	295
8.21	DME RESPIRABLE DUST .....	296
8.22	RESPIRABLE DME COMPARATIVE ANALYSIS.....	299
8.22.1	<i>Mine A Respirable Dust Load Production Analysis .....</i>	299
8.22.2	<i>Mine A Respirable Dust Production Discussion Controls On .....</i>	300
8.22.3	<i>Mine B Respirable Dust Load Production Analysis.....</i>	301
8.22.4	<i>Mine B Respirable Dust Production Discussion Controls On .....</i>	302
8.22.5	<i>Mine C Respirable Dust Load Production Analysis.....</i>	303
8.22.6	<i>Mine C Respirable Dust Production Discussion Controls On.....</i>	304
8.22.7	<i>Mine D Respirable Dust Load Production Analysis .....</i>	305
8.22.8	<i>Mine D Respirable Dust Production Discussion Controls On .....</i>	306
8.22.9	<i>Mine E Respirable Dust Load Production Analysis.....</i>	307
8.22.10	<i>Mine E Respirable Dust Production Discussion Controls On.....</i>	308
8.23	DME INHALABLE DUST .....	309
8.24	INHALABLE DME COMPARATIVE ANALYSIS .....	312
8.24.1	<i>Mine A Inhalable Dust Load Production Analysis .....</i>	312
8.24.2	<i>Mine A Inhalable Dust Production Discussion .....</i>	313
8.24.3	<i>Mine B Inhalable Dust Load Production Analysis .....</i>	314
8.24.4	<i>Mine B Inhalable Dust Production Discussion .....</i>	315
8.24.5	<i>Mine C Inhalable Dust Load Production Analysis .....</i>	316
8.24.6	<i>Mine C Inhalable Dust Production Discussion .....</i>	317
8.24.7	<i>Mine E Inhalable Dust Load Production Analysis .....</i>	318
8.24.8	<i>Mine E Inhalable Dust Production Discussion .....</i>	319

## CHAPTER NINE - BEST PRACTICE FOR LONGWALL DUST

### MITIGATION.....320

9.1	INTRODUCTION .....	320
9.2	PARAMETRIC CONFIGURATION FOR LOC .....	320
9.2.1	<i>LOC Respirable Dust Production Controls On.....</i>	321
9.2.2	<i>LOC Respirable Dust Production Discussion.....</i>	322
9.2.3	<i>LOC Inhalable Dust Production Controls On .....</i>	322
9.2.4	<i>LOC Inhalable Dust Production Discussion .....</i>	323
9.3	PARAMETRIC CONFIGURATION OF THE BELT ROAD .....	323
9.3.1	<i>Belt Road Respirable Dust Production Controls On.....</i>	324
9.3.2	<i>Belt Road Respirable Dust Production Discussion.....</i>	325
9.3.3	<i>Belt Road Inhalable Dust Production Controls On.....</i>	325



9.3.4	<i>Belt Road Inhalable Dust Production Discussion</i> .....	326
9.4	PARAMETRIC CONFIGURATION OF THE BSL DISCHARGE .....	326
9.4.1	<i>BSL Discharge Respirable Dust Production Controls On</i> .....	327
9.4.2	<i>BSL Discharge Respirable Dust Production Discussion</i> .....	328
9.4.3	<i>BSL Discharge Installed Engineering Controls at Mine C for Respirable Dust</i> .....	328
9.4.4	<i>BSL Discharge Inhalable Dust Production Controls On</i> .....	329
9.4.5	<i>BSL Discharge Inhalable Dust Production Discussion</i> .....	330
9.4.6	<i>BSL Discharge Installed Engineering Controls at Mine B for Inhalable Dust</i> .....	330
9.5	PARAMETRIC CONFIGURATION OF THE MAINGATE .....	331
9.5.1	<i>The Maingate Respirable Dust Production Controls On</i> .....	331
9.5.2	<i>The Maingate Respirable Dust Production Discussion</i> .....	332
9.5.3	<i>The Maingate Installed Engineering Controls at Mine A for Respirable Dust</i> .....	332
9.5.4	<i>The Maingate Inhalable Dust Production Controls On</i> .....	333
9.5.5	<i>The Maingate Inhalable Dust Production Discussion</i> .....	334
9.5.6	<i>The Maingate Installed Engineering Controls at Mine E for Inhalable Dust</i> .....	334
9.6	PARAMETRIC CONFIGURATION OF THE TAILGATE .....	335
9.6.1	<i>The Tailgate Respirable Dust Production Controls On</i> .....	335
9.6.2	<i>The Tailgate Respirable Dust Production Discussion</i> .....	336
9.6.3	<i>The Tailgate Installed Engineering Controls at Mine E</i> .....	336
9.6.4	<i>The Tailgate Inhalable Dust Production Controls On</i> .....	337
9.6.5	<i>The Tailgate Inhalable Dust Production Discussion</i> .....	338
9.6.6	<i>The Tailgate Installed Engineering Controls at Mine E for Inhalable Dust</i> .....	338
9.7	RESPIRABLE DUST BEST PRACTICE ENGINEERING CONTROLS .....	339
9.8	INHALABLE DUST BEST PRACTICE ENGINEERING CONTROLS .....	340
9.9	SUMMARY .....	341
<b>CHAPTER TEN – CONCLUSIONS AND RECOMMENDATIONS.....</b>		<b>343</b>
10.1	CONCLUSION .....	343
10.2	RECOMMENDATIONS .....	347
<b>CHAPTER ELEVEN - REFERENCES .....</b>		<b>349</b>
<b>APPENDIX 1 MINE QUESTIONNAIRE .....</b>		<b>355</b>
<b>APPENDIX 2 COAL SERVICES ORDER 40 .....</b>		<b>356</b>
<b>APPENDIX 3 MINE INDUCTION REQUIREMENTS.....</b>		<b>357</b>
<b>APPENDIX 4 RISK ASSESSMENT FOR TESTING .....</b>		<b>447</b>
<b>APPENDIX 5 RISK ASSESSMENT FOR SHEARER TESTING.....</b>		<b>461</b>
<b>APPENDIX 6 – INHALABLE DUST PUMP CALIBRATION .....</b>		<b>477</b>
<b>APPENDIX 7 – RESPIRABLE DUST PUMP CALIBRATION.....</b>		<b>479</b>
<b>APPENDIX 8 – MINE A RESULTS FROM COAL SERVICES .....</b>		<b>482</b>

---

## LIST OF TABLES

Table 1.1 NSW Mines in Order of Tonnes Produced in FY 2011/12 .....	1
Table 1.2 QLD Mines in Order of Tonnes Produced in FY 2011/12 .....	2
Table 1.3 Thick Seam Mines in Australia in Order of Cutting Height .....	2
Table 1.4 Medium Seam Mines in Australia in Order of Cutting Height .....	3
Table 3.1 Size Ranges of Common Particles .....	40
Table 6.1 Example Table of Results .....	113
Table 6.2 Risk Ranking Model.....	131
Table 7.1 Mines where field trials were undertaken, seams and seam thicknesses.....	133
Table 7.2 Mine A Operational Parameters .....	134
Table 7.3 Mine A Installed Engineering Controls .....	143
Table 7.4 Mine B Operating Parameters.....	154
Table 7.5 Mine B Installed Engineering Controls .....	162
Table 7.6 Mine C Operating Parameters.....	173
Table 7.7 Mine C Installed Engineering Controls .....	179
Table 7.8 Mine D Operating Parameters.....	183
Table 7.9 Mine D Installed Engineering Controls .....	186
Table 7.10 Mine E Operating Parameters .....	189
Table 7.11 Mine E Installed Engineering Controls.....	196
Table 8.1 Respirable and Inhalable Data Collected.....	205
Table 8.2 Mine A Respirable And Inhalable Dust Raw Data.....	206
Table 8.3 Mine B Respirable Results Coal Services.....	212
Table 8.4 Mine B Inhalable Results Coal Services.....	213
Table 8.5 Mine B, Test 2 Respirable and Inhalable Dust Raw Data.....	214
Table 8.6 Mine C, Test 3 Respirable Dust Raw Data .....	218
Table 8.7 Mine C, Test 4 Respirable And Inhalable Raw Data.....	221
Table 8.8 Mine C, Test 5 Raw Data.....	226
Table 8.9 Mine B, Test 6 Raw Data.....	231
Table 8.10 Mine B, Test 7 Raw Data.....	236
Table 8.11 Mine D, Test 8 Respirable Raw Data .....	240
Table 8.12 Mine D, Test 9 Respirable Raw Data .....	242
Table 8.13 Mine B, Test 10 Raw Data.....	246
Table 8.14 Mine B, Test 11 Raw Data.....	250
Table 8.15 Mine E, Test 12 Raw Data.....	254
Table 8.16 Mine C, Test 13 Coal Services Scrubber Testing.....	258
Table 8.17 Mine C, Test 14 Raw Data.....	262
Table 8.18 Mine C, Test 13 & 14 DME Comparison Using Test 4 Benchmark Raw Data.....	267
Table 8.19 Mine E, Test 15 Raw Data.....	269

---

Table 8.20 Test 12 and 13 Comparison .....	273
Table 8.21 Respirable Dust Production Benchmark Samples .....	274
Table 8.22 Inhalable Dust Production Benchmark Samples .....	285
Table 8.23 Respirable DME Samples .....	296
Table 8.24 Inhalable Dust Production DME Samples .....	309
Table 9.1 LOC Average Respirable Dust Production Controls On .....	321
Table 9.2 LOC Inhalable Dust Production Controls On .....	322
Table 9.3 Belt Road Average Respirable Dust Production Controls On .....	324
Table 9.4 Belt Road Inhalable Dust Production Controls On .....	325
Table 9.5 BSL Discharge Average Respirable Dust Production Controls On .....	327
Table 9.6 BSL Discharge Installed Engineering Controls at Mine C for Respirable Dust .....	329
Table 9.7 BSL Discharge Inhalable Dust Production Controls On .....	329
Table 9.8 BSL Discharge Installed Engineering Controls at Mine B for Inhalable Dust .....	331
Table 9.9 The Maingate Average Respirable Dust Production Controls On .....	331
Table 9.10 The Maingate Installed Engineering Controls at Mine A for Respirable Dust .....	333
Table 9.11 The Maingate Inhalable Dust Production Controls On .....	333
Table 9.12 The Maingate Installed Engineering Controls at Mine E for Inhalable Dust .....	335
Table 9.13 The Tailgate Average Respirable Dust Production Controls On .....	335
Table 9.14 The Tailgate Installed Engineering Controls at Mine E .....	337
Table 9.15 The Tailgate Inhalable Dust Production Controls On .....	337
Table 9.16 The Tailgate Installed Engineering Controls at Mine E for Inhalable Dust .....	339
Table 9.17 Respirable Dust Best Practice Engineering Controls .....	339
Table 9.18 Inhalable Dust Best Practice Engineering Controls .....	340

---

## LIST OF FIGURES

Figure 2.1 Particle Drag and Terminal Velocity Diagram .....	10
Figure 2.2 Drag Force for Different Particle Shapes .....	11
Figure 2.3 Comparative Particle Sizing .....	14
Figure 2.4 Particle Size Deposition in the Human Airway Tract .....	17
Figure 2.5 Human Airway Tract .....	18
Figure 2.6 Diagram Showing Important Deposition Mechanisms .....	19
Figure 2.7 Sedimentation of an Inhaled Particle .....	20
Figure 2.8 Inertial Impaction of an Inhaled Particle .....	23
Figure 2.9 Diffusion of an Inhaled Particle .....	24
Figure 2.10 Interception of an Inhaled Particle .....	25
Figure 2.11 X-ray Showing Simple Pneumoconiosis .....	32
Figure 2.12 X-ray Showing Complicated Pneumoconiosis .....	32
Figure 2.13 Healthy Lung and Lung with CWP .....	33
Figure 2.14 Normal Lung .....	35
Figure 2.15 Simple Silicosis .....	36
Figure 2.16 Healthy Lung .....	37
Figure 2.17 Complicated Silicosis .....	37
Figure 3.1 Sources of Dust Generation on Longwalls .....	42
Figure 3.2 Total Face Dust as a Percentage Generated from Independent Sources .....	42
Figure 3.3 Typical Last Open Cut-Through .....	43
Figure 3.4 Typical Outbye Belt Road .....	44
Figure 3.5 Typical BSL Discharge .....	45
Figure 3.6 Typical Crusher Intake .....	46
Figure 3.7 Dust Being Entrained into the Walkway From Raised Drum .....	47
Figure 3.8 Dust Entrained into Walkway From Drum Cutting Floor .....	47
Figure 3.9 Dust From a Chock as it is Moved Forward .....	48
Figure 3.10 Dust From a Chock as it is Set to the Roof .....	49
Figure 4.1 Conveyor Belt on the Intake to the Crusher .....	54
Figure 4.2 Conveyor Belt Strips Inside the Crusher Before the Hammers .....	55
Figure 4.3 Typical Skirting Arrangement for The Coal Discharge onto the Outbye Belt .....	55
Figure 4.4 Typical Spray Setup to Suppress Dust from the Face to Crusher Intake .....	56
Figure 4.5 Typical Hollow Cone Sprays Inside the Crusher .....	57
Figure 4.6 Typical Spray Setup Inside the BSL Discharge .....	57
Figure 4.7 Typical Electric Drive Dust Scrubber Fitted to a BSL .....	58
Figure 4.8 Pick Spray Behind the Pick on the Shearer Drum .....	59
Figure 4.9 Typical Spray Insert in Drum Sprays .....	59

---

Figure 4.10 Typical Crescent Spray Setup .....	60
Figure 4.11 Typical Shearer Clearer Setup .....	61
Figure 4.12 Spray Manifold Positioned on the Maingate Arm .....	62
Figure 4.13 Shearer Scrubber .....	62
Figure 4.14 Canopy Sprays .....	63
Figure 4.15 Typical Canopy Spray .....	64
Figure 4.16 Venturi Spray Installed on BSL Maingate .....	65
Figure 4.17 Venturi Sprays Installed at Chock # 5 .....	65
Figure 6.1 DME Model Flowchart .....	90
Figure 6.2 Pump and Head Placement to Sample Longwall .....	92
Figure 6.3 Pumps and Heads Positioned in LOC .....	93
Figure 6.4 Pump and Head Placement in Belt Road .....	94
Figure 6.5 BSL Discharge .....	95
Figure 6.6 Pump and Head Placement at Chock #5 .....	95
Figure 6.7 Data Collection Preparation Process Flowchart .....	99
Figure 6.8 Label Preparation Process .....	100
Figure 6.9 Filter Head Identification Process .....	102
Figure 6.10 Pre-Weighing Filter Process .....	105
Figure 6.11 Head Loading Process .....	107
Figure 6.12 Post-Weigh Process .....	110
Figure 6.13 The Universal Pump by SKC .....	125
Figure 6.14 Respirable Cyclone Head .....	126
Figure 6.15 IOM Inhalable Fraction Head .....	127
Figure 7.1 Mine A pump and head location .....	135
Figure 7.2 Mine A Pump and Head Location in LOC .....	136
Figure 7.3 Mine A Pump and Head Location in the Belt Road .....	137
Figure 7.4 Mine A Pump and Head Location at BSL Discharge .....	138
Figure 7.5 Mine A Location of Personal Samplers .....	139
Figure 7.6 Mine A Pump and Head Location Over Crusher Intake .....	140
Figure 7.7 Mine A Pump and Head Location for Inadequate Crusher and BSL Sealing .....	141
Figure 7.8 Mine A Placement of Pumps and Heads on the Underside of Chocks .....	142
Figure 7.9 Mine A Pump and Head Location in the Tailgate .....	143
Figure 7.10 Mine A BSL Discharge Skirting and Code 96 Cluster Spray .....	145
Figure 7.11 Mine A Code 96 Cluster Spray .....	145
Figure 7.12 Mine A Spray Inside Discharge Hood .....	146
Figure 7.13 Mine A Rubber Skirting at Intake to Crusher .....	147
Figure 7.14 Mine A Rubber Strips Before Crusher .....	147
Figure 7.15 Mine A Installed Sprays Before Crusher .....	148
Figure 7.16 Mine A Flat Fan Sprays at AFC/Maingate Transfer and Directional Wing .....	149
Figure 7.17 Mine A Installed BSL Scrubber .....	150

---

Figure 7.18 Mine A Installed Drum Sprays Behind Pick.....	151
Figure 7.19 Mine A Drum Spray Insert .....	151
Figure 7.20 Mine A “Rocket Sprays” .....	152
Figure 7.21 Mine A Installed Chock Sprays .....	153
Figure 7.22 Mine B Pump and Head Location .....	155
Figure 7.23 Mine B Pump and Head Location In LOC .....	156
Figure 7.24 Mine B Pump and Head Location in the Belt Road .....	157
Figure 7.25 Mine B Pump and Head Location at BSL Discharge .....	158
Figure 7.26 Mine B Pump and Head Location for Crusher Dust on Chock #2 .....	159
Figure 7.27 Mine B Location of Personal Samplers .....	160
Figure 7.28 Mine B Placement of Pumps and Heads on Chocks.....	161
Figure 7.29 Mine B Pump and Head Location in the Tailgate .....	162
Figure 7.30 Mine B BSL Discharge Skirting .....	164
Figure 7.31 Mine B Sprays Inside Discharge Hood.....	164
Figure 7.32 Mine B Rubber Skirting at Intake to Crusher .....	165
Figure 7.33 Mine B Installed Sprays in Spray Bar in Crusher .....	166
Figure 7.34 Mine B Spray Bar Location Holes in Crusher .....	166
Figure 7.35 Mine B Installed Spray Bar in Crusher.....	167
Figure 7.36 Mine B Dropper Spray at Maingate and Directional Wing.....	168
Figure 7.37 Mine B Code 96 Fitted to Dropper Spray .....	168
Figure 7.38 Mine B Dropper Spray at Chock #5 .....	169
Figure 7.39 Mine B Maingate Directional Wing .....	169
Figure 7.40 Mine B Installed BSL Scrubber .....	170
Figure 7.41 Mine B Installed Drum Sprays Behind Pick .....	171
Figure 7.42 Mine B Drum Spray Insert .....	171
Figure 7.43 Mine B Installed Chock Sprays .....	172
Figure 7.44 Mine C Pump and Head Location .....	174
Figure 7.45 Mine C Pump and Head Location in LOC.....	175
Figure 7.46 Mine C Pump And Head Location In The Belt Road.....	176
Figure 7.47 Mine C Pump and Head Location Inbye of BSL Discharge .....	177
Figure 7.48 Mine C Pump and Head Location for Crusher Dust on Chock #5 .....	178
Figure 7.49 Mine C Placement of Pumps and Heads on Tailgate Chocks .....	179
Figure 7.50 Mine C Installed BSL Scrubber .....	181
Figure 7.51 Mine C Installed Drum Sprays Behind Pick .....	182
Figure 7.52 Mine C Drum Spray Insert .....	182
Figure 7.53 Mine D Pump and Head Location .....	184
Figure 7.54 Mine D Installed Drum Sprays Behind Pick.....	188
Figure 7.55 Mine D Drum Spray Insert .....	188
Figure 7.56 Mine E Pump and Head Location .....	191
Figure 7.57 Mine E Pump and Head Location in LOC .....	192

---

Figure 7.58 Mine E Pump and Head Location in the Belt Road.....	193
Figure 7.59 Mine E Pump and Head Location for BSL Discharge.....	194
Figure 7.60 Mine E Pump and Head Location for Crusher Dust on Chock .....	195
Figure 7.61 Mine E Pump and Head Location in the Tailgate .....	196
Figure 7.62 Mine E BSL Discharge Skirting .....	198
Figure 7.63 Mine E Hollow Cone Sprays Inside Discharge Hood .....	198
Figure 7.64 Mine E Crusher Intake Sprays .....	199
Figure 7.65 Mine E Sprays on Rear AFC .....	200
Figure 7.66 Mine E Rear Caving Sprays.....	201
Figure 7.67 Mine E Installed Drum Sprays and Pick.....	202
Figure 7.68 Mine E Installed Chock Sprays.....	203
Figure 7.69 Mine E Side Chock Sprays .....	203
Figure 8.1 Mine A Respirable Dust Production Controls Off and On .....	207
Figure 8.2 Mine A Respirable DME.....	208
Figure 8.3 Mine A Inhalable Dust Production.....	209
Figure 8.4 Mine A Inhalable DME.....	210
Figure 8.5 Mine A Average Respirable and Inhalable DME.....	210
Figure 8.6 Mine B, Test 2 Respirable Dust Production .....	215
Figure 8.7 Mine B, Test 2 Respirable DME.....	215
Figure 8.8 Mine B, Test 2 Inhalable Dust Production.....	216
Figure 8.9 Mine B, Test 2 Inhalable DME.....	217
Figure 8.10 Mine C, Test 3 Respirable Dust Production.....	219
Figure 8.11 Mine C, Test 3 Respirable DME.....	219
Figure 8.12 Mine C, Test 4 Respirable Dust Production.....	222
Figure 8.13 Mine C, Test 4 Respirable DME.....	222
Figure 8.14 Mine C, Test 4 Inhalable Dust Production.....	223
Figure 8.15 Mine C, Test 4 Inhalable DME.....	224
Figure 8.16 Mine C, Test 5 Respirable Dust Production.....	226
Figure 8.17 Mine C, Test 5 Respirable DME.....	227
Figure 8.18 Mine C, Test 5 Inhalable Dust Production.....	228
Figure 8.19 Mine C, Test 5 Inhalable DME .....	228
Figure 8.20 Mine B, Test 6 Respirable Dust Production.....	232
Figure 8.21 Mine B, Test 6 Respirable DME.....	232
Figure 8.22 Mine B, Test 6 Inhalable Dust Production.....	234
Figure 8.23 Mine B, Test 6 Inhalable DME .....	234
Figure 8.24 Mine B, Test 7 Respirable Dust Production.....	237
Figure 8.25 Mine B, Test 7 Respirable DME.....	237
Figure 8.26 Mine B, Test 7 Inhalable Dust Production.....	238
Figure 8.27 Mine B, Test 7 Inhalable DME .....	239
Figure 8.28 Mine D, Test 8 Respirable Dust Production Benchmark #1 .....	241

---

Figure 8.29 Mine D, Test 9 Respirable Dust Production Benchmark #2 .....	242
Figure 8.30 Mine D, Test 8 & 9 Respirable Benchmark Comparison .....	243
Figure 8.31 Mine D, Test 8 & 9 Benchmark Dust Load Difference .....	243
Figure 8.32 Mine D Average Respirable Dust Production Comparison .....	244
Figure 8.33 Mine D Average Respirable Dust Production Comparison .....	244
Figure 8.34 Mine B, Test 10 Respirable Dust Production.....	246
Figure 8.35 Mine B, Test 10 Respirable DME.....	247
Figure 8.36 Mine B, Test 10 Inhalable Dust Production.....	248
Figure 8.37 Mine B, Test 10 Inhalable DME.....	248
Figure 8.38 Mine B, Test 11 Respirable Dust Production.....	250
Figure 8.39 Mine B, Test 11 Respirable DME.....	251
Figure 8.40 Mine B, Test 11 Inhalable Dust Production.....	252
Figure 8.41 Mine B, Test 11 Inhalable DME.....	252
Figure 8.42 Mine E, Test 12 Respirable Dust Production.....	255
Figure 8.43 Mine E, Test 12 Respirable DME .....	255
Figure 8.44 Mine E, Test 12 Inhalable Dust Production .....	256
Figure 8.45 Mine E, Test 12 Inhalable DME .....	256
Figure 8.46 Mine C, Test 13 Respirable Dust Production.....	259
Figure 8.47 Mine C, Test 13 Respirable DME.....	259
Figure 8.48 Mine C, Test 13 Inhalable Dust Production.....	260
Figure 8.49 Mine C, Test 13 Inhalable DME.....	261
Figure 8.50 Mine C, Test 14 Respirable Dust Production.....	263
Figure 8.51 Mine C, Test 14 Respirable DME.....	263
Figure 8.52 Mine C, Test 14 Inhalable Dust Production.....	264
Figure 8.53 Mine C, Test 14 Inhalable DME.....	265
Figure 8.54 Mine C, Test 13 and 14 Respirable DME Comparison Using Test 4 Benchmark.....	267
Figure 8.55 Mine C, Test 13 and 14 Inhalable DME Comparison Using Test 4 Benchmark.....	268
Figure 8.56 Mine E, Test 15 Respirable Dust Production.....	270
Figure 8.57 Mine E, Test 15 Respirable DME .....	270
Figure 8.58 Mine E, Test 15 Inhalable Dust Production .....	271
Figure 8.59 Mine E, Test 15 Inhalable DME .....	272
Figure 8.60 Mine Average Respirable Benchmark Dust Production .....	275
Figure 8.61 Average Respirable Benchmark Dust Production Comparison.....	275
Figure 8.62 Respirable Benchmark Dust Load Production Comparative Analysis .....	276
Figure 8.63 Mine A Respirable Dust Production Benchmark Comparison.....	277
Figure 8.64 Mine A Average Respirable Dust Production Difference.....	277
Figure 8.65 Test Average and Mine A Average Respirable Benchmark Dust Production .....	278
Figure 8.66 Mine B Respirable Dust Production Benchmark Comparison.....	279
Figure 8.67 Mine B Average Respirable Dust Production Difference .....	279
Figure 8.68 Test Average and Mine B Average Respirable Benchmark Dust Production .....	280



---

Figure 8.69 Mine C Respirable Dust Production Benchmark Comparison .....	281
Figure 8.70 Mine C Average Respirable Dust Production Difference .....	281
Figure 8.71 Test Average and Mine C Average Respirable Benchmark Dust Production .....	282
Figure 8.72 Mine E Respirable Dust Production Benchmark Comparison .....	283
Figure 8.73 Mine E Average Respirable Dust Production Difference .....	283
Figure 8.74 Test Average and Mine E Average Respirable Benchmark Dust Production .....	284
Figure 8.75 Mine Average Inhalable Benchmark Dust Production .....	286
Figure 8.76 Average Inhalable Benchmark Dust Production Comparison .....	286
Figure 8.77 Inhalable Benchmark Dust Load Production Comparative Analysis .....	287
Figure 8.78 Mine A Inhalable Dust Production Benchmark Comparison .....	288
Figure 8.79 Mine A Average Inhalable Dust Production Difference .....	288
Figure 8.80 Test Average and Mine A Average Inhalable Benchmark Dust Production .....	289
Figure 8.81 Mine B Inhalable Dust Production Benchmark Comparison .....	290
Figure 8.82 Mine B Average Inhalable Dust Production Difference .....	290
Figure 8.83 Test Average and Mine B Average Inhalable Benchmark Dust Production .....	291
Figure 8.84 Mine C Inhalable Dust Production Benchmark Comparison .....	292
Figure 8.85 Mine B Average Inhalable Dust Production Difference .....	292
Figure 8.86 Test Average and Mine C Average Inhalable Benchmark Dust Production .....	293
Figure 8.87 Mine E Inhalable Dust Production Benchmark Comparison .....	294
Figure 8.88 Mine E Average Inhalable Dust Production Difference .....	294
Figure 8.89 Test Average and Mine E Average Inhalable Benchmark Dust Production .....	295
Figure 8.90 Mine Average Respirable Dust Production Controls On .....	297
Figure 8.91 Average Respirable Dust Production Comparison Controls On .....	298
Figure 8.92 Respirable Average DME Comparative Analysis .....	298
Figure 8.93 Mine A Respirable Dust Production Comparison Controls On .....	299
Figure 8.94 Mine A Average Respirable DME .....	299
Figure 8.95 Test Average and Mine A Average Respirable Dust Production Controls On .....	300
Figure 8.96 Mine B Respirable Dust Production Comparison Controls On .....	301
Figure 8.97 Mine B Average Respirable DME .....	301
Figure 8.98 Test Average and Mine B Average Respirable Dust Production Controls On .....	302
Figure 8.99 Mine C Respirable Dust Production Comparison Controls On .....	303
Figure 8.100 Mine B Average Respirable DME .....	303
Figure 8.101 Test Average and Mine C Average Respirable Dust Production Controls On .....	304
Figure 8.102 Mine D Respirable Dust Production Comparison Controls On .....	305
Figure 8.103 Mine D Average Respirable DME .....	305
Figure 8.104 Test Average and Mine D Average Respirable Dust Production Controls On .....	306
Figure 8.105 Mine E Respirable Dust Production Comparison Controls On .....	307
Figure 8.106 Mine E Average Respirable DME .....	307
Figure 8.107 Test Average and Mine E Average Respirable Dust Production Controls On .....	308
Figure 8.108 Mine Average Inhalable Dust Production Controls On .....	310

---

Figure 8.109 Average Inhalable Benchmark Dust Production Comparison.....	311
Figure 8.110 Inhalable Average DME Comparative Analysis .....	311
Figure 8.111 Mine A Inhalable Dust Production Comparison Controls On.....	312
Figure 8.112 Mine A Average Inhalable DME .....	312
Figure 8.113 Test Average and Mine A Average Inhalable Dust Production Controls On.....	313
Figure 8.114 Mine B Inhalable Dust Production Comparison Controls On .....	314
Figure 8.115 Mine B Average Inhalable DME.....	314
Figure 8.116 Test Average and Mine B Average Inhalable Dust Production Controls On .....	315
Figure 8.117 Mine C Inhalable Dust Production Comparison Controls On .....	316
Figure 8.118 Mine C Average Inhalable DME.....	316
Figure 8.119 Test Average and Mine C Average Inhalable Dust Production Controls On.....	317
Figure 8.120 Mine E Inhalable Dust Production Comparison Controls On .....	318
Figure 8.121 Mine E Average Inhalable DME.....	318
Figure 8.122 Test Average and Mine E Average Inhalable Dust Production Controls On .....	319
Figure 9.1 LOC Respirable Dust Production Controls On .....	321
Figure 9.2 LOC Inhalable Dust Production Controls On .....	323
Figure 9.3 Belt Road Respirable Dust Production Controls On .....	325
Figure 9.4 Belt Road Inhalable Dust Production Controls On .....	326
Figure 9.5 BSL Discharge Respirable Dust Production Controls On .....	328
Figure 9.6 BSL Discharge Inhalable Dust Production Controls On .....	330
Figure 9.7 The Maingate Respirable Dust Production Controls On .....	332
Figure 9.8 The Maingate Inhalable Dust Production Controls On.....	334
Figure 9.9 The Tailgate Respirable Dust Production Controls On .....	336
Figure 9.10 The Tailgate Inhalable Dust Production Controls On.....	338

---

## LIST OF EQUATIONS

Equation 2.1	Volume Equivalent Sphere Diameter .....	12
Equation 2.2	Surface Equivalent Sphere Diameter .....	12
Equation 2.3	Stokes Diameter .....	13
Equation 2.4	Hydrodynamic Equivalent Diameter .....	13
Equation 2.6	Inertial Impaction Formula .....	22
Equation 6.1	Blank Corrected Filter Weight.....	111
Equation 6.2	Average Flow Rate.....	111
Equation 6.3	Volume of Air.....	111
Equation 6.4	Average Concentration .....	112
Equation 6.5	Dust Mitigation Efficiency .....	112

---

## GLOSSARY OF TERMS

***Aerodynamic diameter:*** Particles of a given aerodynamic diameter move within the air spaces of the respiratory system identically, regardless of density or shape.

***Chronic obstructive pulmonary disease (COPD):*** Includes chronic bronchitis (inflammation of the lung airways associated with cough and phlegm production), impaired lung function, and emphysema (destruction of the air spaces where gas transfer occurs). COPD is characterized by irreversible (although sometimes variable) obstruction of lung airways.

***Coal workers' pneumoconiosis (CWP):*** A chronic dust disease of the lung arising from employment in an underground coal mine. In workers who are or have been exposed to coal mine dust, diagnosis is based on the radiographic classification of the size, shape, profusion, and extent of parenchymal opacities.

***Crystalline silica:*** Silicon dioxide (SiO<sub>2</sub>). "Crystalline" refers to the orientation of SiO<sub>2</sub> molecules in a fixed pattern as opposed to a nonperiodic, random molecular arrangement defined as amorphous. The three most common crystalline forms of free silica encountered in general industry are quartz, tridymite, and cristobalite. In coal mines, the predominant form is quartz.

***Inhalable coal mine dust:*** That portion of airborne dust in coal mines that is capable of entering the gas-exchange regions of the lungs if inhaled: by convention, a particle-size-selective fraction of the total airborne dust; includes particles with aerodynamic diameters less than approximately 20 μm.

***Progressive massive fibrosis:*** Coal workers' complicated pneumoconiosis. Diagnosis is based on determination of the presence of large opacities (1 cm or larger) using radiography or the finding of specific lung pathology on biopsy or autopsy.

***Quartz:*** Crystalline silicon dioxide (SiO<sub>2</sub>) not chemically combined with other substances and having a distinctive physical structure.

---

***Respirable coal mine dust:*** That portion of airborne dust in coal mines that is capable of entering the gas-exchange regions of the lungs if inhaled: by convention, a particle-size-selective fraction of the total airborne dust; includes particles with aerodynamic diameters less than approximately 10  $\mu\text{m}$ .

## **CHAPTER ONE – GENERAL INTRODUCTION**

### **1.1 General**

Production from longwall mining in Australia has increased remarkably over the last several years. This increased productivity has meant that more dust is being produced and controlling respirable and inhalable dust continues to present one of the greatest ongoing challenges for coal mine operators. A report by the director of mine safety operations branch of Industry & Investment NSW has found that there is an increasing level of dust being ingested by coal miners in New South Wales, potentially leading to long-term health problems (ILN, 2010). This increased exposure level for underground workers can be directly attributed to the increase in coal production and the continued development of medium and thick seam mines in Australia which allow the installation of bigger and more productive longwall equipment.

Currently in Australia there are 29 operating longwall coal mines. Of these 29, there are 19 operating in NSW and 10 operating in QLD. NSW longwalls mined a total of 45,102,400 tonnes of coal in Financial Year (FY) 2011/12 whilst QLD longwalls mined a total of 33,345,800 for the same period. Table 1.1 details NSW mines in order of tonnes produced in FY 2011/12 (ILN, 2012).

**Table 1.1 NSW Mines in Order of Tonnes Produced in FY 2011/12 (ILN, 2012)**

<b>Mine</b>	<b>Longwall Production</b>
Ulan	5,440,100
Mandalong	4,836,100
North Wambo	4,565,500
Dendrobium	3,861,600
Angus Place	3,525,500
Appin/Appin West	3,193,100
West Wallsend	2,922,800
Tahmoor	2,438,400
West Cliff	2,293,900
Ravensworth	2,075,000
Springvale	1,971,000

**CHAPTER ONE**  
**General Introduction**

Austar	1,658,800
Metropolitan	1,595,200
Integra	1,417,900
Ashston	1,376,800
NRE Wongawili	741,200
Chain Valey (b)	599,000
Blakefield South (a)	413,600
NRE No1 (c)	176,900
<b>Total</b>	<b>45,102,400</b>

Table 1.2 details QLD mines in order of tonnes produced in FY 2011/12.

**Table 1.2 QLD Mines in Order of Tonnes Produced in FY 2011/12 (ILN, 2012)**

Mine	Longwall Production
Oaky North	7,187,200
Kestrel	5,000,000
Grasstree	3,775,900
Oaky Creek No1	3,488,200
Moranbah North	3,172,100
Broadmeadow	3,104,800
Newlands Northern	2,347,800
Carborough Downs	2,018,900
Crinum East/North	2,018,900
North Goonyella	1,232,000
<b>Total</b>	<b>33,345,800</b>

Australia currently has 10 thick seam mines operating. Thick seam mines have been characterised as cutting heights greater than 3.5m (Atkinson, 1979). The remaining 19 longwall mines are characterised as medium seam mines, that is, greater than 2.1m cutting height.

Table 1.3 details the thick seam mines in Australia in order of cutting height.

**Table 1.3 Thick Seam Mines in Australia in Order of Cutting Height (ILN, 2012)**

Mine	State	Cutting Height (m)
Mandalong	NSW	4.8
Broadmeadow	Qld	4.8
Newlands Northern	Qld	4.5
Moranbah North	Qld	4.5
North Goonyella	Qld	4.5
Carborough Downs (a)	Qld	4.5
West Wallsend	NSW	4.0
Dendrobium	NSW	3.7
NRE Wongawilli (formerly Delta / Elouera)	NSW	3.7
Oaky North	Qld	3.6

**CHAPTER ONE**  
**General Introduction**

---

Table 1.4 details the medium thickness seam mines in Australia in order of cutting height.

**Table 1.4 Medium Seam Mines in Australia in Order of Cutting Height (ILN, 2012)**

Mine	State	Cutting Height (m)
Crinum East	Qld	3.4
Ulan	NSW	3.2
Angus Place	NSW	3.2
Springvale	NSW	3.2
Metropolitan	NSW	3.2
Appin / Appin West	NSW	3.2
Beltana / Blakefield South	NSW	3.1
Kestrel	Qld	3.0
Oaky Creek No1 (d)	Qld	2.9
Austar	NSW	2.9
Ravensworth (formerly Newpac No1)	NSW	2.8
Bundoora	Qld	2.8
Integra (formerly Glennies Creek)	NSW	2.8
Grasstree	Qld	2.7
West Cliff	NSW	2.7
Ashton	NSW	2.7
Baal Bone	NSW	2.7
North Wambo	NSW	2.5
Tahmoor	NSW	2.1

Although the industry has had some success in the control of respirable dust, such control strategies have not been readily transferred to the control of inhalable dust, and according to a Safety Alert issued by the Department of Investment and Industry, improved dust control measures will be required in the underground coal mines of NSW, especially longwall mines in the Newcastle and Hunter Valley districts, to control inhalable dust (ILN, 2010).

Studies by NIOSH in the USA have shown that prolonged exposure to excessive levels of airborne respirable coal dust can lead to Coal Workers' Pneumoconiosis (CWP), Progressive Massive Fibrosis (PMF), and Chronic Obstructive Pulmonary Disease (COPD) (NIOSH, 2010). These diseases are irreversible and can be debilitating, progressive and potentially fatal. The continued occurrence of CWP in underground coal mine workers and the magnitude of respirable and inhalable dust overexposures in longwall mining occupations illustrate the need for the mining industry to improve existing dust control technology on longwalls not only the USA,



## **CHAPTER ONE**

### **General Introduction**

---

but Australia as well to prevent the incidence of lung diseases from occurring in Australia and from escalating to epidemic scales in the USA.

Fugitive dust on longwalls has always been an issue of concern for production, safety and the health of workers in the underground coal mining industry both in Australia and globally. Longwall personnel can be exposed to harmful dust from multiple dust generation sources including, but not limited to: intake entry, belt entry, stageloader/crusher, shearer, chock advance and dust ingress from falling goaf or over pressurisation of the goaf. With the increase in production created from the advancement in longwall equipment, dust loads have also increased and this has resulted in an increase in exposure levels to personnel.

Only a small fraction of respirable and inhalable dust becomes airborne during the cutting cycle, yet it is still too much to be sufficiently diluted by the ventilation airflow so as to maintain respirable and inhalable dust levels to statutory levels. Studies have shown that for every 1,000 tonnes of coal produced, 0.5 to 1.5 mg/m<sup>3</sup> of respirable dust is added to the longwall face atmosphere (Bell., *etal*, 1993). Installed engineering controls have been shown to effectively control longwall respirable and inhalable dust for production levels of between 2,000 - 3,000 tonnes/shift (Balusu, 1993), however, with current longwall production of greater than 6,000 tonnes per shift, installed controls are no longer capable of ensuring compliance with statutory levels.

## **1.2 Statement of the problem**

Fugitive dust on longwalls has always been an issue of concern for production, safety and the health of workers in the underground coal mining industry both in Australia and globally. Longwall personnel can be exposed to harmful respirable and inhalable dust from multiple dust generation sources including, but not limited to: intake entry, belt entry, stageloader/crusher, shearer, and chock advance. With the increase in production created from the advancement in longwall equipment, dust loads have also increased and this has resulted in an increase in exposure levels to personnel. The industry has been using statutory dust measurements in underground coal mines

## **CHAPTER ONE**

### **General Introduction**

---

conducted by both SIMTARS and Coal Services which rely on AS 2985 for respirable size dust particles, and AS 3640 for inhalable size dust particles. The majority of dust sampling to date has been done with cyclone separation and collection of the sized particles for weighing, generally over the period of a full shift. Although this method provides an accurate measurement for the total dust exposure for the period sampled, it does not always accurately reflect the source, quantity and timing of respirable dust entering the longwall from different sources, hence presents difficulties in determining the relative effectiveness of the different control technologies in use.

A recent investigation conducted by the US National Public Radio (NPR) and its partner on the project the Center for Public Integrity (CPI) have determined that black lung in the USA has soared to “epidemic” levels and cases have doubled among America’s coal miners over the past decade. It has also been determined that this increase in the incidence of black lung has occurred as a result of protective regulations not keeping pace with the increase in coal production due to mechanisation (ILN, 2012).

The research reveals cases of advanced black lung have spiked more than fourfold since the 1980s and while black lung experts and advocates of mine safety had pushed warnings of the disease’s resurgence in coal for the past 17 years, the mining industry and federal regulators had known about miners’ exposure and associated issues but the system for controlling dust had been weak. Additionally, in its data review, NPR said inaccurate reporting of compliance dust sampling sometimes included fraud.

NPR and the CPI also argue in their report that regulations have not run parallel with the escalation of black lung. The last significant amendment to federal law that included coal mine dust exposure was the Federal Coal Mine Health and Safety Act of 1969, which set a standard for coal dust exposure of 2 milligrams per cubic meter of air, or about 25% of the concentrations miners at the time were taking in. The act also included free diagnostic chest X-rays every five years and also called for a federal compensation program for those diagnosed with the disease. NPR and CPI have reiterated the findings of the Davitt McAteer report which found that autopsies of the

## **CHAPTER ONE**

### **General Introduction**

---

29 victims from the Upper Big Branch mine explosion in 2010 showed that among the 24 victims with sufficient lung tissue for testing, 71% had evidence of the disease including lung nodules and lesions. According to McAteer, the prevalence rate is ten times the average for that region of southern West Virginia.

NIOSH consultant Edward Peterson, a West Virginia University pulmonologist has commented that from the patterns, the severity, and from the prevalence of black lung, there must be a situation in which the dust in many mines is simply not adequately controlled (ILN, 2012).

In contrast, Australia has not experienced such a dramatic increase in black lung as that seen in the United States. According to Coal Services, there are no known cases of black lung currently in Australia (Mace, 2008). Mace suggests that the reason for this is the existing testing regime which differs significantly from the current testing in the US. This difference is discussed in detail in Chapter 5.

### **1.3 Aims and Objectives**

The objective of this thesis is to conduct a comprehensive monitoring survey on representative longwalls (medium to thick seams) to quantify and document respirable and inhalable dust magnitudes being generated from different sources on an operating longwall, using gravimetric sampling as per statutory requirements, and to quantify installed control efficiencies for dust mitigation on longwalls.

Specifically, this thesis aims to:

- Measure and quantify dust loads at identified sources of dust generation utilising traditional gravimetric sampling;
- Evaluate current dust controls and their effectiveness at each of the sources of dust generation;
- Analyse the most effective control process in place for each source of dust generation at other operating longwall mines in both Australia and globally;

## **CHAPTER ONE**

### **General Introduction**

---

- Design of a monitoring process and best practices for implementation on Australia longwalls to minimise dust exposure levels.

This thesis will involve a detailed study of operational and management practices (e.g. cutting methods, ventilation, water sprays, operator position and shift rotation etc.) affecting dust control and exposure levels. It is anticipated that the monitoring data will be extrapolated to predict dust load distributions including both respirable and inhalable dust. The expected outcomes from this thesis include;

- A new dust monitoring methodology to establish benchmark dust loads from different sources;
- Identification of limitations and merits of current dust control practices;
- Formulation and implementation of best practices and monitoring process to mitigate dust exposure levels for longwall workers; and
- Identification of new areas for improving dust controls and associated technologies.

This thesis will enhance the current practices of statutory dust monitoring and offer significant benefit to the coal mining industry by providing benchmark dust load monitoring procedures and identification along with the implementation of best mitigation practices and therefore reduced dust exposure levels of longwall workers to statutory requirements.

#### **1.4 Thesis outline**

Chapter 1 presents the general purpose of the research, a statement of the problem forming the foundation of the thesis work and a scope of works designed to achieve the required outcome of the study.

Chapter 2 defines respirable and inhalable dust fractions, discusses how particles are deposited on the human airway tract, the physiological effects of the deposited dust and the types of lung disease that are created by this deposited dust.

## **CHAPTER ONE**

### **General Introduction**

---

Chapter 3 describes where respirable and inhalable dust is generated on an operating longwall and Chapter 4 details the engineering controls currently installed in Australian longwalls to mitigate the produced respirable and inhalable dust.

Chapter 5 describes the current methods for monitoring respirable and inhalable dust production in both Australia and the USA and discusses the limitation with the current testing regime.

Chapter 6 presents the new testing methodology developed to determine dust loads as opposed to exposure levels and introduces the concept and practical application of the Dust Mitigation Efficiency (DME) model and the data collection process.

Chapter 7 details the field trials undertaken at Australian longwalls for the thesis and describes in detail the current controls installed on these longwalls for respirable and inhalable dust mitigation.

Chapter 8 presents the results of the respirable and inhalable sampling undertaken using the DME model and discusses the results of each of the samples taken at each of the mines tested.

Chapter 9 analyses the most efficient parametric configuration of installed controls for mitigation of respirable and inhalable dust at the samples sources of dust generation and provides a best practice parametric set up to maximise dust mitigation efficiencies at known sources of dust generation on operating longwalls.

Chapter 10 is the thesis conclusion and recommendations for further research and studies.

## CHAPTER TWO - DUST: DEFINITIONS, DEPOSITION AND PHYSIOLOGICAL EFFECTS

### 2.1 Dust Definition

Dust has been defined by the International Standardisation Organisation (ISO 4225-ISO, 1994) as “Small solid particles, conventionally taken as those particles 75  $\mu\text{m}$  in diameter, which settle out under their own weight but which may stay suspended for some time” (WHO, 1999). Dust has further been defined as "Small, dry, solid particles projected into the air by natural forces, such as wind, volcanic eruption, and by mechanical or man-made processes such as crushing, grinding, milling, drilling, demolition, shovelling, conveying, screening, bagging, and sweeping. Dust particles are usually in the size range from about 1 to 100  $\mu\text{m}$  in diameter, and they settle slowly under the influence of gravity” (IUPAC, 1990). The Mine Safety and Health Administration (MSHA, 1989) define dust as finely divided solids that may become airborne from the original state without any chemical or physical change other than fracture. Dust consists of tiny solid particles carried by air currents. These particles are formed by a disintegration or fracture process, such as grinding, crushing, or impact (USDOL, 2008).

Particle size is considered the most important physical characteristic of airborne particulate matter (WHO, 1984).

Particle size is a linear length measure, measured in SI unit ( $\mu\text{m}$ ). In this sense it can be uniquely defined only for spheres, where it is the diameter (or radius). For all other shapes, particle size must be clearly defined via a measuring procedure. Further research suggests that it is an oversimplification to refer to the particle size of dust as “particle diameter” alone (WHO, 1999). The size of a particle is usually defined by its diameter, unless its geometric shape is known (WHO, 1984).

However, the diameter of the particle gives no explanation as to how the particle actually behaves once it has become airborne. Therefore, it has been further suggested

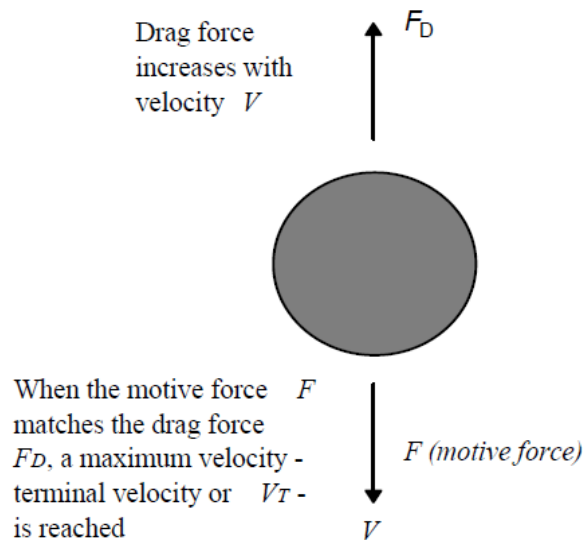
## CHAPTER TWO

### Dust: Definitions, Deposition and Physiological Effects

---

that the most appropriate measure of particle size, for most occupational hygiene situations, is particle aerodynamic diameter. This definition has been derived from the falling velocity of a particle in still air. When a particle is released from rest and falls in still air, it is subject to the downward force of gravity and the opposing aerodynamic drag of the atmosphere (WHO, 1984). The balance between these opposing forces is readily achieved and the particle falls at a steady velocity known as its terminal velocity (WHO, 1999, and Park, 2012). Figure 2.1 shows a diagrammatic representation of the terminal velocity achieved by a particle in motion.

### Particle drag and terminal velocity



**Figure 2.1 Particle Drag and Terminal Velocity Diagram (Park, 2012)**

The World Health Organisation (WHO) has defined particle aerodynamic diameter as "the diameter of a hypothetical sphere of density  $1 \text{ g/cm}^3$  having the same terminal settling velocity in calm air as the particle in question, regardless of its geometric size, shape and true density." The aerodynamic diameter expressed in this way is appropriate because it relates closely to the ability of the particle to penetrate and deposit at different sites of the respiratory tract, as well as to particle transport in aerosol sampling and filtration devices (WHO, 1999).

## CHAPTER TWO

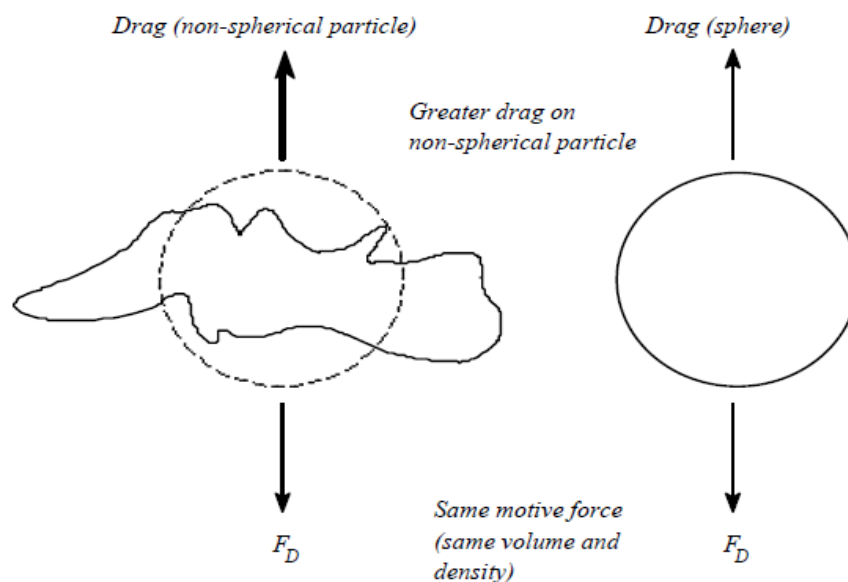
### Dust: Definitions, Deposition and Physiological Effects

---

Particle shape is a complex geometric characteristic. It involves the form and habit of the particle as well as features like convexity and surface roughness. The science on shape characterization is broad and so is the number of possible definitions of shape factors. Furthermore, particles actually exist in the shape of a non-sphere and it is therefore difficult to determine the particle size by particle diameter alone (Pabst and Gregorová, 2007).

Therefore, particle diameters can also be determined by measuring a size-dependent property of the particle and relating it to a single linear dimension. The most widely used of these are the *equivalent diameters*, in particular the equivalent spherical diameters (Pabst and Gregorová, 2007). The equivalent diameter is determined as dust particles will fall at a different terminal velocity to that of a sphere, due to the irregularity of the particle shape. Figure 2.2 details the reason for the difference in particle terminal velocity to the terminal velocity of a sphere.

## Drag force for different shape of particle



**Figure 2.2 Drag Force for Different Particle Shapes (Park, 2012)**



## CHAPTER TWO

### Dust: Definitions, Deposition and Physiological Effects

---

A further alternative description sometimes used for particle size is the Stokes' equivalent diameter, which refers to the physical diameter of a spherical particle of the same average density and the same falling speed. According to this description the terminal settling velocity of a spherical particle with a diameter in the range of 1 to 50  $\mu\text{m}$  is proportional to its density and to the square of its diameter. Particles that are not spherical usually fall at a slower rate than predicted by Stokes' relationship, because of their larger projected surface area per unit mass, which creates more resistance to their falling (WHO, 1984).

Important equivalent diameters are:

- Volume-equivalent sphere diameter  $D_{volume}$  = diameter of a sphere with the same volume as the particle  $V_{particle}$ , i.e.

$$D_{volume} = \left( \frac{6}{\pi} V_{particle} \right)^{1/3}$$

#### Equation 2.1 Volume Equivalent Sphere Diameter (Pabst and Gregorová, 2007)

e.g. for a cube with edge length  $1\mu\text{m}$  (volume  $1\mu\text{m}^3$ ) we have  $D_{volume} = 1.24\mu\text{m}$ .

- Surface-equivalent sphere diameter  $D_{surface}$  = diameter of a sphere with the same surface as the particle  $S_{particle}$ , i.e.

$$D_{surface} = \left( \frac{6}{\pi} S_{particle} \right)^{1/2}$$

#### Equation 2.2 Surface Equivalent Sphere Diameter (Pabst and Gregorová, 2007)

e.g. for a cube with edge length  $1\mu\text{m}$  (surface  $6\mu\text{m}^2$ ) we have  $D_{surface} = 1.38\mu\text{m}$ .

## CHAPTER TWO

### Dust: Definitions, Deposition and Physiological Effects

---

- Stokes diameter  $D_S$  = equivalent diameter corresponding to the diameter of a sphere with the same final settling velocity as the particle undergoing laminar flow in a fluid of the same density and viscosity), defined via the Stokes relation

$$D_S = \sqrt{\frac{18\eta v}{(\rho_S - \rho_L)g}},$$

#### Equation 2.3 Stokes Diameter (Pabst and Gregorová, 2007)

where  $\eta$  is the viscosity (of the pure liquid medium without particles),  $\rho_S$  the density of the solid particles,  $\rho_L$  the density of the pure liquid,  $g$  the gravitational acceleration and  $v$  the final settling velocity.

- Hydrodynamic equivalent diameter  $D_H$  (= diameter of a sphere with the same translational diffusion coefficient  $D_{translation}$  as the particle in the same fluid under the same conditions), defined via the Stokes-Einstein relation *translation*

$$D_H = \frac{kT}{3\pi\eta D_{translation}},$$

#### Equation 2.4 Hydrodynamic Equivalent Diameter (Pabst and Gregorová, 2007)

where  $k$  is the Boltzmann constant,  $T$  the absolute temperature and  $\eta$  the viscosity of the liquid medium (the diffusion coefficient must be extrapolated to zero concentration) (Pabst and Gregorová, 2007).

It is generally accepted in aerosol science that particles with aerodynamic diameter  $>50 \mu\text{m}$  do not usually remain airborne very long: they have a terminal velocity  $>7\text{cm/sec}$ . However, depending on the conditions, particles even  $>100 \mu\text{m}$  may

## CHAPTER TWO

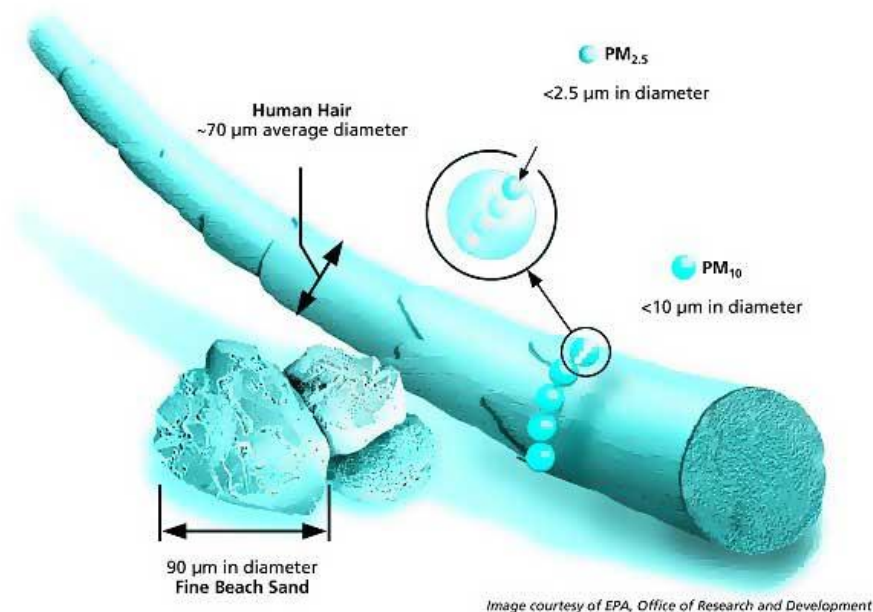
### Dust: Definitions, Deposition and Physiological Effects

---

become (but hardly remain) airborne. Furthermore, dust particles are frequently found with dimensions considerably  $<1 \mu\text{m}$  and, for these, settling due to gravity is negligible for all practical purposes. The terminal velocity of a  $1 \mu\text{m}$  particle is about  $0.03 \text{ mm/sec}$ , so movement with the air is more important than sedimentation through it. Therefore, it is considered that dusts are solid particles, ranging in size from  $1 \mu\text{m}$  up to at least  $100 \mu\text{m}$ , which may be or may become airborne, depending on their origin, physical characteristics and ambient conditions (WHO, 1999).

## 2.2 Dust Fractions

The size of contaminants and particles are usually described in microns ( $\mu\text{m}$ ), a metric unit of measure where one micron is one-millionth of a meter. There are *25,400 microns* in one inch. The eye can see particles to about  $40 \mu\text{m}$  (Engineering Toolbox, 2012). Figure 2.3 shows a diagrammatic comparison of particle sizing.



**Figure 2.3 Comparative Particle Sizing (US EPA Office of Research and Development, 2012).**

Airborne particles are solids suspended in the air and are defined in sections 2.2.1 and 2.2.2.

## CHAPTER TWO

### Dust: Definitions, Deposition and Physiological Effects

---

#### 2.2.1 Inhalable Dust

Inhalable dust is that sized fraction that can penetrate the head airways and enter the airways of the lung. Examples of dusts for which this fraction is of particular concern include cotton and other dusts causing airway disease. Inhalable dust particles are hazardous when deposited anywhere within the lung airways, including the mouth and nose. Inhalable fractions can enter the nose and mouth during normal breathing and the particles are between 10 and 100  $\mu\text{m}$  diameter. Inhalable fractions are commonly referred to as  $\text{PM}_{10}$ . Other specific characteristics are:

- Sedimentation velocities are greater than  $0.2 \text{ m/s}$ ;
- Particles settle out slowly;
- Particles include fine ice crystals, pollen, hair, large bacteria, windblown dust, fly ash, coal dust, silt, fine sand, and small dust.

#### 2.2.2 Respirable Dust

Respirable dust is defined as that fraction of the dust reaching the alveolar region of the lungs. Respirable dust is that fraction of inhaled airborne particles that can penetrate beyond the terminal bronchioles into the gas-exchange region of the lungs. Examples of dusts for which the respirable fraction offers greatest hazard include quartz and other dusts containing free crystalline silica; cobalt-containing and other hard metal dust produced by grinding masonry drill bits; and many others. Respirable particles that will penetrate into the gas exchange region of the lungs. Respirable particles are a hazardous particulate size less than 10  $\mu\text{m}$ . Respirable fractions are commonly referred to as  $\text{PM}_{2.5}$ . Other specific characteristics are:

- The particles fall slowly and may take days or even years to settle out of a quiet atmosphere. In a turbulent atmosphere they may never settle out;
- They can be washed out by water or rain;
- They may include viruses, small bacteria, metallurgical fumes, soot, oil smoke, tobacco smoke, clay, and fumes (Engineering Toolbox, 2012, WHO, 1999, and McPherson, 2009).

## CHAPTER TWO

### Dust: Definitions, Deposition and Physiological Effects

---

#### 2.3 Particle Deposition in the Human Airway Tract

The largest inhaled particles, with aerodynamic diameter greater than about 30  $\mu\text{m}$ , are deposited in the airways of the head, that is, the air passages between the point of entry at the lips or nose and the larynx. During nasal breathing, particles are deposited in the nose by filtration by the nasal hairs and impaction where the airflow changes direction. Retention after deposition is helped by mucus, which lines the nose. In most cases, the nasal route is a more efficient particle filter than the oral, especially at low and moderate flow rates. Thus, people who normally breathe part or all of the time through the mouth may be expected to have more particles reaching the lung and depositing there than those who breathe entirely through the nose. During exertion, the flow resistance of the nasal passages causes a shift to mouth breathing in almost all people. Other factors influencing the deposition and retention of particles include cigarette smoking and lung disease.

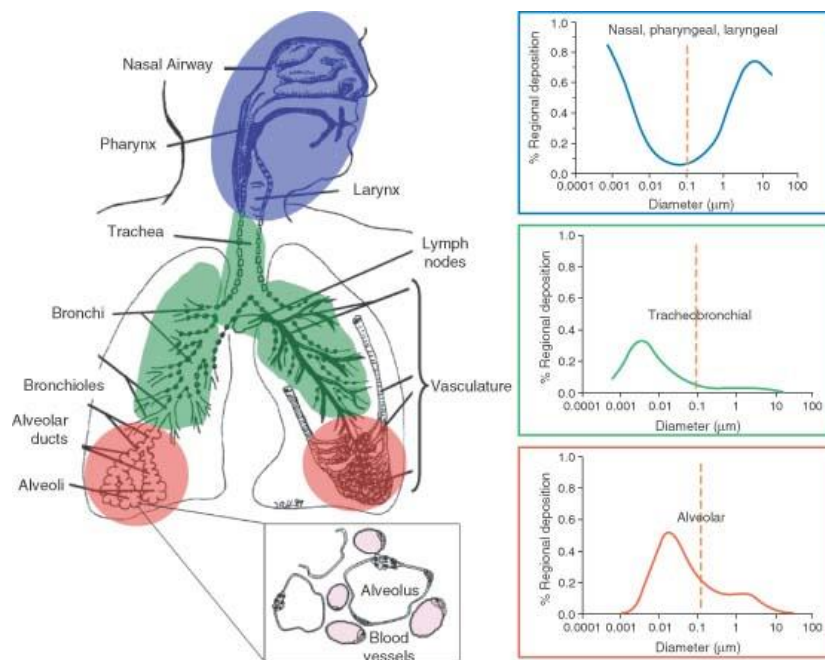
Of the particles which fail to deposit in the head, the larger ones will deposit in the tracheobronchial airway region and may later be eliminated by mucociliary clearance. The smaller particles may penetrate to the alveolar region, the region where inhaled gases can be absorbed by the blood. In aerodynamic diameter terms, only about 1% of 10 $\mu\text{m}$  particles get as far as the alveolar region, so 10  $\mu\text{m}$  is usually considered the practical upper size limit for penetration to this region. Maximum deposition in the alveolar region occurs for particles of approximately 2  $\mu\text{m}$  aerodynamic diameter. Most particles larger than this have deposited further up the lung. For smaller particles, most deposition mechanisms become less efficient, so deposition is less for particles smaller than 2  $\mu\text{m}$  until it is only about 10-15% at about 0.5  $\mu\text{m}$ . Most of these particles are exhaled again without being deposited. For still smaller particles, diffusion becomes an effective mechanism and deposition probability is higher. Deposition is therefore a minimum at about 0.5  $\mu\text{m}$  (WHO, 1994, and McPherson, 2009).

## CHAPTER TWO

### Dust: Definitions, Deposition and Physiological Effects

Particles small enough to stay airborne may be inhaled through the nose (nasal route) or the mouth (oral route). The probability of inhalation depends on particle aerodynamic diameter, air movement round the body, and breathing rate. Dust particles in the fraction range of 2-5  $\mu\text{m}$  will penetrate deeper into the lungs than larger dust particle fractions (Horiba, 2010, Engineering Toolbox, 2012, WHO, 1999, and McPherson, 2009).

Figure 2.4 shows particle size deposition in the human airway tract.



**Figure 2.4 Particle Size Deposition in the Human Airway Tract (USDOL, 2008)**

The purpose of the lungs is to supply oxygen needed by the body's cells and to remove produced carbon dioxide. This process is referred to as gas exchange. As shown in Figure 2.5, air entering through the nose or mouth passes through a filter of hairs called cilia, in order to enter a larger chamber where the air velocity is reduced, called the nasopharynx (U.S. Department of Labor, Mine Safety and Health Administration, 2008). This nasal region is the first line of defence against airborne particulates and removes the larger dust particles by causing the inhaled air to swirl around the bone and cartilage in the nasal region and become trapped in the cilia. Those particles remain trapped in the cilia until they are blown out or pass back

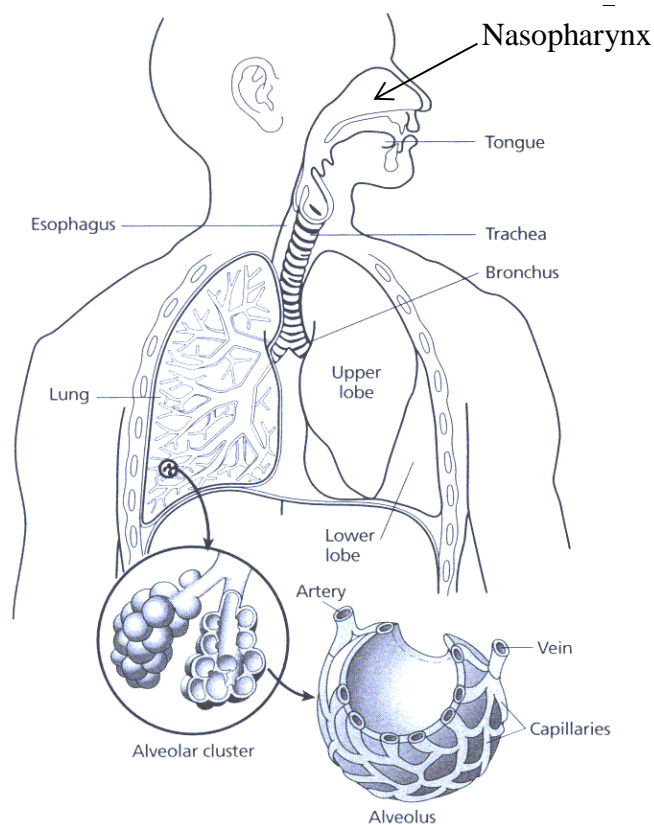
## CHAPTER TWO

### Dust: Definitions, Deposition and Physiological Effects

---

through the nasopharynx to be swallowed. Throughout the nasopharynx and all of the branched air passages leading to the alveoli, the walls are lined with cilia and mucous-secreting cells which wave to and fro with a directional bias that promotes movement of the mucous towards the throat where it can be swallowed.

This process is called mucociliary action. Most dust particles greater than  $10\ \mu\text{m}$  in size are captured by the hair filter or mucous before inhaled air reaches the larynx. Inhalation of air through the mouth bypasses the protection offered by the nostrils and nasopharynx (McPherson, 2009).



**Figure 2.5 Human Airway Tract (USDOL, 2008)**

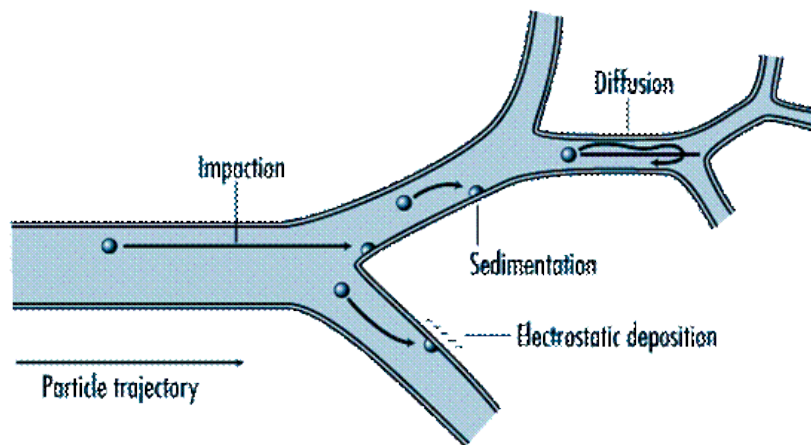
Once inhaled, the particles may then either be deposited into the human airway tract or exhaled again, depending on a range of physiological and particle-related factors and environmental parameters (WHO, 1999, McPherson 2009, and Engineering Toolbox, 2012).

## CHAPTER TWO

### Dust: Definitions, Deposition and Physiological Effects

---

There are five mechanisms for dust fractions to be deposited into the human airway tract. These are *sedimentation*, *inertial impaction*, *diffusion* (significant only for very small particles  $< 0.5 \mu\text{m}$ ), *interception*, and *electrostatic deposition* (Pabst and Gregorová, 2007, McPherson, 2009, WHO, 1999, and Breysse, *et al.*, 2006). Figure 2.6 shows where in the lungs dust articles are deposited. Sedimentation, impaction and diffusion are the most important mechanisms in relation to inhaled airborne dust, and these processes are governed by particle aerodynamic diameter (Breysse, *et al.*, 2006).



**Figure 2.6 Diagram Showing Important Deposition Mechanisms (Breysse, et.al, 2006)**

### 2.3.1 Sedimentation

Sedimentation is the tendency for particles in suspension to settle out of the medium in which they are suspended, in this instance the particles are suspended in the inhaled air of the lungs, and come to rest against a Barrier. This is due to their motion through the air in response to the forces acting on them. In relation to dust deposition in the lungs, this term refers to the gravitational settlement of dust particles and is most effective at low air velocities for dust particles greater than  $0.5 \mu\text{m}$ . Smaller particles become subject to Brownian motion (see 2.3.1.1) and diffusion effects (see 2.3.3). Sedimentation assists in the deposition of larger particles in the nasopharynx during the reversal points of the breathing cycle, ie, exhalation. More importantly, however,



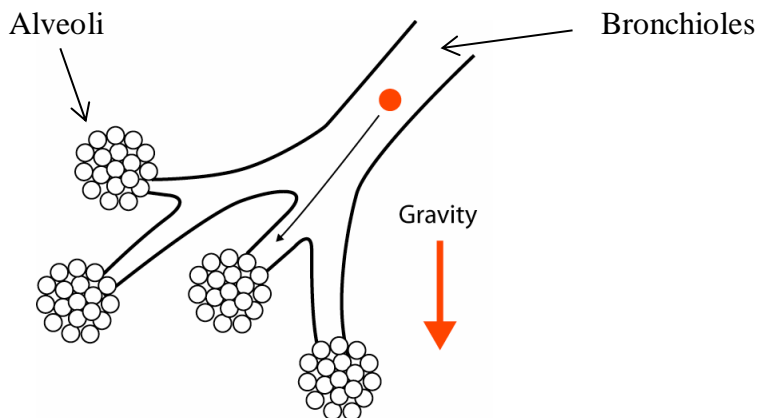
## CHAPTER TWO

### Dust: Definitions, Deposition and Physiological Effects

sedimentation is an effective mechanism of deposition in the low velocity laminar flows within the finer bronchioles and the alveoli (McPherson, 2009).

Another factor that aids dust particle deposition is that the full capacity of human lungs is seldom used. During normal breathing the volume of air inhaled into the lungs may utilise only up to 65 to 75 percent of lung capacity. Sedimentation of dust particles will occur in the stagnant air of the unused dead-space. A phase of heavy breathing followed by a normal breathing period will first draw dust particles into the deeper recesses of the lung and then encourage deposition by sedimentation in the dead-space as breathing becomes shallower (McPherson, 2009).

Figure 2.7 shows a diagrammatic representation of the sedimentation process by which a particle in an airstream is pulled downward through the bronchioles by gravity until it strikes a stationary obstacle (e.g. alveoli) and is removed from the air (Breyse, *et al.*, 2006).



Adapted from <http://www.mfg.mtu.edu/cyberman/environment/air/depos.html>

**Figure 2.7 Sedimentation of an Inhaled Particle (Michigan Tech, 2012)**

#### 2.3.1.1 Brownian Motion

Brownian motion is the path taken when a particle moves randomly in d-dimensional space without making very big jumps. On the microscopic level, at any time step, the particle receives a random displacement, caused for example by other particles hitting it or by an external force, for example gravity (MörTERS and Peres, 2012). Brownian motion has been defined in the Columbian Dictionary as a zigzag, irregular motion

## CHAPTER TWO

### Dust: Definitions, Deposition and Physiological Effects

---

exhibited by minute particles of matter when suspended in a fluid. It has further been defined by the American Heritage Dictionary as the random movement of

microscopic particles suspended in a liquid or gas, caused by collisions with molecules of the surrounding medium. Brownian motion has been observed in all types of colloidal suspensions solid-in-liquid, liquid-in-liquid, gas-in-liquid, solid-in-gas, and liquid-in-gas. The effect, being independent of all external factors, is ascribed to the thermal motion of the molecules of the fluid. These molecules are in constant irregular motion with a velocity proportional to the square root of the temperature. Small particles of matter suspended in the fluid are buffeted about by the molecules of the fluid. Brownian motion is observed for particles about 0.001 mm in diameter; these are small enough to share in the thermal motion, yet large enough to be seen with a microscope or ultramicroscope (American Heritage Dictionary, 2012).

#### 2.3.2 Inertial Impaction

Inertial impaction is the deposition of large aerosol particles on the walls of an airway conduit. The impaction tends to occur where the airway direction changes. Small particles have less inertia and are more likely to be carried around corners and continue in the path of the airflow (Mosby Medical Dictionary, 2009).

Due to inertia, a dust particle moving in a lung airstream can strike stationary obstacles in its path. As the airstream deflects around the obstacle, the particle continues toward the object and impacts it. The obstacle in the lung is usually the alveoli at the end of the branching bronchioles as shown in Figure 2.8 (USEPA, 2012).

The efficiency of impaction is directly proportional to the impaction parameter shown in Equation 2.6. As the value of this parameter increases, the efficiency of inertial impaction increases. This parameter is related to the square of the Stokes particle diameter and the velocity of the particle. (USEPA, 2012).

## CHAPTER TWO

### Dust: Definitions, Deposition and Physiological Effects

---

$$K_I = \frac{C_c d_{ps}^2 v \rho_p}{18 \mu D_c}$$

#### Equation 2.5 Inertial Impaction Formula (USEPA, 2012)

Where:

- $K_I$  = Impaction parameter (dimensionless)
- $C_c$  = Cunningham slip correction factor (dimensionless)
- $d_{ps}$  = Stokes particle diameter (micrometers)
- $v$  = Difference in velocity (cm/sec)
- $\rho_p$  = Particle density (gm/cm<sup>3</sup>)
- $D_c$  = Diameter of droplet (cm)
- $\mu$  = Gas viscosity (gm/cm-sec)

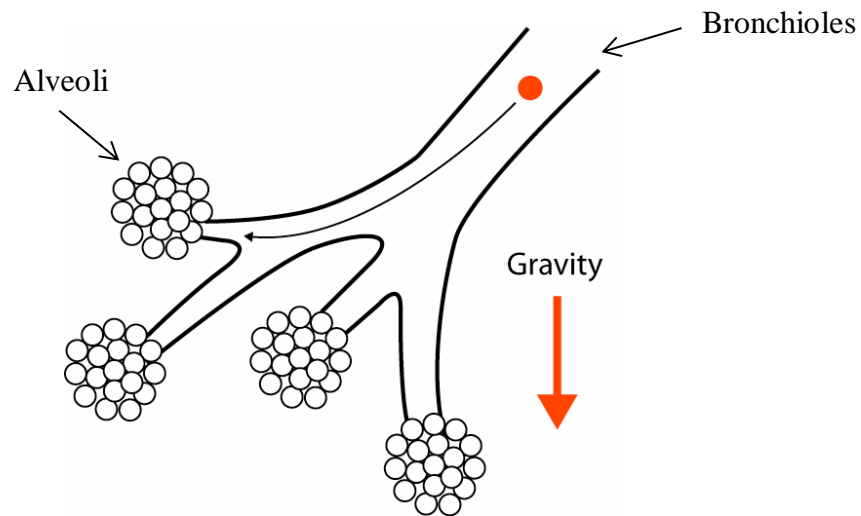
The density and, therefore, the momentum of dust particles are greater than that of a comparable volume of air in the lungs. At each bend of the lung passages followed by air during inhalation and exhalation, dust particles will tend to follow a straight line as they cannot turn as quick as the air, resulting in the dust particle impacting into the mucous coated walls of the lung passages. The effectiveness of deposition by impaction increases with the acuteness of the bend and the velocity of the air. Constriction of air passages by thickening of the mucous layer, bronchial infections or lung damage will result in higher air velocities and increased deposition by impaction. Inertial impaction is usually highly efficient for particles larger than 10  $\mu\text{m}$  and subsequently becomes progressively less effective as the particle size decreases. Impaction is not efficient for particles less than 0.3  $\mu\text{m}$  due to their low inertia (USEPA, 2012, and McPherson, 2009).

Figure 2.8 is a diagrammatic representation of inertial impaction whereby a particle moving in branching bronchioles is unable to remain in the airstream when there is a change in direction. As a result, the particle strikes a stationary obstacle (e.g., surface in respiratory system) directly in its path and is removed from the air (Breysse, *etal.*, 2006).

## CHAPTER TWO

### Dust: Definitions, Deposition and Physiological Effects

---



Adapted from <http://www.mfg.mtu.edu/cyberman/environment/air/depos.html>

**Figure 2.8 Inertial Impaction of an Inhaled Particle (Michigan Tech, 2012)**

### 2.3.3 Diffusion

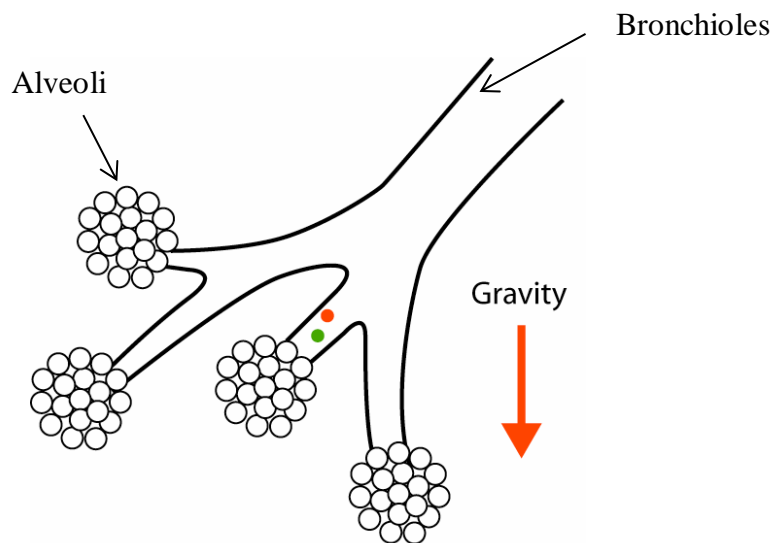
Diffusion becomes the dominant collection mechanism for dust particles less than  $0.3\mu\text{m}$  and is especially significant for particles in the  $0.01$  to  $0.1\mu\text{m}$  size range. Very small dust particles in lung passages deflect slightly when struck by larger particles. Transfer of kinetic energy from the larger particle to the small particle causes this deflection (Brownian motion, see 2.3.1.1). These small particles are then captured when they impact the mucous wall of the lung or alveoli as a result of this random movement (USEPA, 2012).

The effect of diffusion increases as the size of the particles decreases and becomes significant for particle diameters of less than  $0.5\mu\text{m}$ . Although Brownian motion occurs throughout the respiratory system, it becomes an effective mode of dust deposition only when the mean displacement becomes comparable with the size of the air passage. Hence, it is particularly important in the alveoli and finer bronchioles (McPherson, 2009). Figure 2.9 is a diagrammatic representation of the diffusion process by which the dust particles will strike a stationary obstacle after being randomly deflected by a change in direction or other surface in the respiratory system (Breysse, *etal.*, 2006).

## CHAPTER TWO

### Dust: Definitions, Deposition and Physiological Effects

---



Adapted from <http://www.mfg.mtu.edu/cyberman/environment/air/depos.html>

**Figure 2.9 Diffusion of an Inhaled Particle (Michigan Tech, 2012)**

#### 2.3.4 Interception

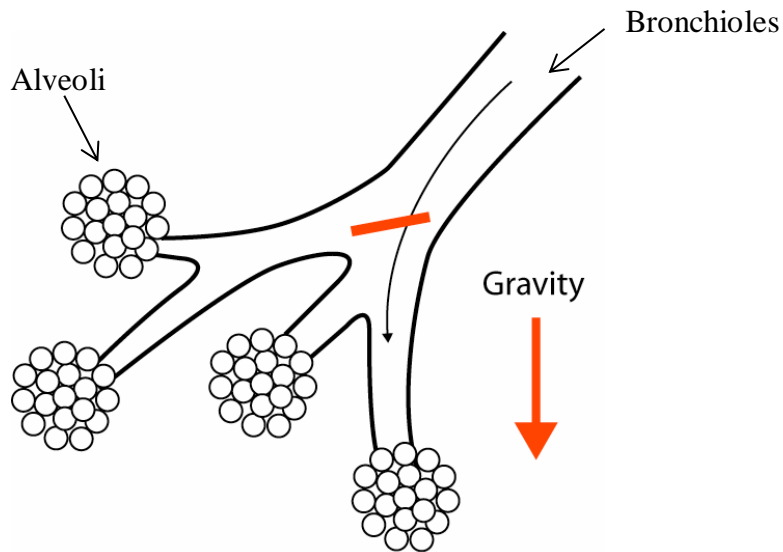
Interception becomes significant for fibrous particles. A dust fibre is often defined as a particle where the length to diameter ratio exceeds 3. Such particles tend to align themselves with the direction of airflow and fibres 200  $\mu\text{m}$  long can penetrate deeply into the lung. Nevertheless, the ends of fibres are likely to contact the walls of air passages, particularly at bends and bifurcations, and accumulations of fibres can occur at these locations. This is the mechanism of interception (McPherson, 2009, and Breysse, *etal.*, 2006).

Figure 2.10 is a diagrammatic representation of the interception process whereby a particle moving in lung airstream remains in that airstream but, because of its dimensions, strikes a stationary obstacle (e.g., surface in respiratory system) and is removed from the air (Breysse, *etal.*, 2006).

## CHAPTER TWO

### Dust: Definitions, Deposition and Physiological Effects

---



Adapted from <http://www.mfg.mtu.edu/cyberman/environment/air/depos.html>

**Figure 2.10 Interception of an Inhaled Particle (Michigan Tech, 2012)**

### 2.3.5 Electrostatic Deposition

Electrostatic deposition is defined as a process in which electrostatic charges cause particles to deposit on another surface as a result of magnetic attraction (ORC, 2012).

Within the working areas of a mine, newly produced particles of mineral dust may carry a substantial electrostatic charge. The moving electromagnetic fields that surround such particles can induce magnetic charges on these particles which, when inhaled, can bond with the opposite electrical charge on the walls of air passages in the respiratory system. This results in the electrostatic precipitation of particles on to the walls and captured by the film of mucous (McPherson, 2009).

## 2.4 Physiological Effects of Dust on the Human Body

Respiratory problems caused by exposure to dust are among the oldest identified industrial diseases. Early medical opinions in the 1920's, suggested that only hardrock workers were exposed to potential lung diseases from dust. It was identified at the

## CHAPTER TWO

### Dust: Definitions, Deposition and Physiological Effects

---

time that silicosis from hardrock mining led to tuberculosis and eventual death (McPherson, 2009). During that time coal dust was not regarded as particularly harmful. However, during the 1930's, the number of recognized cases of pneumoconiosis increased dramatically resulting in the British Medical Research Council initiating an investigation into respirable disease within the black coal workers of South Wales. Europe and the United States had previously identified the hazards of dust in coal mines and by 1950 it was confirmed that workers in bituminous coal mines were also exposed to potential dust diseases, particularly pneumoconiosis (McPherson, 2009).

However, it took many years for a definitive association to be established between the atmospheric contaminants in an operating coal mine and respiratory dysfunction of coal workers exposed to these atmospheric contaminants. McPherson suggests that there were three reasons for this delay in recognising the association between airborne contaminants and lung disease. Firstly, it takes years of exposure to coal dust before the coal mine worker shows signs of lung disease and suffers significant breathing impairment whilst performing normal activities. Secondly, the onset of lung disease often presents symptoms similar to those of naturally occurring ailments such as coughing, wheezing, shortness of breath and flu like symptoms. Thirdly, at the time, the commonly used method for determining the dust concentration level in the atmosphere was to measure the number of particles in a unit volume of air. However, the relationship between dust levels measured as a particle count in a unit volume of air and the incidence of pneumoconiosis in coal workers was not completely understood (McPherson, 2009).

At the International Pneumoconiosis Conference held in Johannesburg, South Africa in 1959, a re-direction of pneumoconiosis studies was recommended, with particular focus being directed at the limitations to the existing methods of dust sampling. Studies had identified that those particles of equivalent diameter less than  $5\mu\text{m}$  were the particles most likely to be retained within the lungs and create lung disease in coal mine workers. These size particle fractions were named respirable dust. Studies further established that the mass concentration of respirable dust in any given

## CHAPTER TWO

### Dust: Definitions, Deposition and Physiological Effects

---

atmosphere, over the period of a shift (usually 8 hours) was a much better measure of the potential health hazard to a coal mine worker than the existing particle count methods (McPherson, 2009). It was from this point forward that the Time Weighted Average (TWA) method of determining exposure levels was implemented and statutorily enforced. It was also at this time that equipment capable of measuring TWA's in the atmosphere was developed.

Lung diseases caused by the inhalation of coal dust are known by the general term pneumoconiosis. This is often referred to as dusted or black lung.

The changes which occur in the lungs vary with the deposition of the different dust fractions. For example, the inhalation and subsequent deposition of coal dust in the lungs can initially cause symptoms such as;

- coughing;
- wheeze, or worsening of asthma;
- increased need for medications (eg: puffers, antibiotics);
- increased breathlessness; and
- flu like symptoms.

Continued exposure and inhalation of coal dust can then lead to pneumoconiosis, Coal Workers Pneumoconiosis (CWP) and Progressive Massive Fibrosis (PMF).

In contrast, lung disease caused by exposure to silica is much more severe and identified by areas of scar tissue surrounded by normal lung tissue. Because the injured areas are separated from each other by normal tissue, the lungs do not completely lose their elasticity. Some particles are dissolved in the blood stream and then carried around the body where it may affect the brain, kidneys and other organs (CCOHS, 2012).



## CHAPTER TWO

### Dust: Definitions, Deposition and Physiological Effects

---

Health effects resulting from exposure to pneumoconiosis may not appear for many years and may in fact only appear after exposure has ceased. This delay in the production of symptoms from this exposure may then be mistakenly attributed to non-occupational conditions such as smoking. Another more serious example is the identification of the fatal lung disease mesothelioma. Mesothelioma results from exposure to asbestos fibres and cases of the disease have appeared over 40 years after actual exposure to the asbestos have occurred. It is important for hygienists, and other professionals in this field, to consider the fact that although exposed workers may not display any symptoms of lung disease, it should not be assumed that significant lung damage has not already occurred. It is now recognised that shorter exposures to higher concentrations of pneumoconiosis-producing dusts, has produced cases of acute lung disease. (WHO, 1999, and DOL Federal Register, 2010)

#### 2.4.1 Dust Classifications

Within the alveoli are cells called *macrophages* (i.e., scavenger cells) that are released by the stimulus of foreign bodies, such as dust. The macrophages engulf the dust particles deposited in the lung. Some of the dust-laden macrophages, which have the ability to move freely within the air spaces of the lung and alveoli, are removed from the lung by two different pathways (WHO, 1999, McPherson, 2009, and USDOL, 2008).

##### 2.4.1.1 Mucociliary Escalator

The dust-laden macrophages move to the finer bronchioles, from which further clearance takes place by mucociliary action, as described. Eventually these cells, along with the coarser particles initially deposited within the upper respiratory tract, reach the mouth and are swallowed or expelled via spitting or coughing. Most of the dust deposited in the alveolar spaces is removed in this manner (WHO, 1999, McPherson, 2009, and USDOL, 2008).

## **CHAPTER TWO**

### **Dust: Definitions, Deposition and Physiological Effects**

---

#### **2.4.1.2 Lymphatic System**

Dust-laden macrophage cells may pass through the alveolar walls of the lungs into the lymphatic system, which starts as a mesh of fine vessels and drains the tissue spaces. These vessels come together to form larger and larger vessels that eventually discharge the lymph into the bloodstream. At the various branching points (bifurcations) of the trachea and the bronchi, the lymph passes through glands termed lymph nodes, one of whose functions is the filtration of foreign bodies. Hence, a great deal of particulate matter is deposited by the macrophages at the lymph nodes, and it is here that fibrosis of healthy tissue often starts. Other dust-laden cells may be deposited and remain on the alveolar walls where, again, fibrosis can be initiated (USDOL, 2008).

A classification of dusts with respect to potential hazard to the health and safety of industrial workers may be divided into five categories.

#### **2.4.1.3 Toxic Dusts**

These can cause chemical reactions within the respiratory system or allow toxic compounds to be absorbed into the bloodstream through the alveolar walls. They are poisonous to body tissue or to specific organs. Coal dust is not typically classified as a toxic dust (USDOL, 2008).

#### **2.4.1.4 Carcinogenic Dusts**

A combination of abrasion of lung tissue and surface chemical action can result in tumour formation from freshly produced quartz particles. Studies have identified that an excessive risk for lung cancer in certain dust producing occupations exists. These included dust producing occupations such as mining, although coal-mine workers were not specifically identified. Increased lung cancer risk among coal-mine workers

## **CHAPTER TWO**

### **Dust: Definitions, Deposition and Physiological Effects**

---

appears to be found only in those with exposure to high levels of crystalline silica (IARC, 1997, AIOH, 2009, and WHO, 1994).

#### **2.4.1.5 Fibrogenic Dusts**

The scouring action of many dusts causes microscopic scarring of lung tissue. If continued over long periods this can produce a fibrous growth of tissue resulting in loss of lung elasticity and a greatly reduced area for gas exchange and lead to pneumoconiosis and CWP (IARC, 1997, AIOH, 2009, and WHO, 1994).

#### **2.4.1.6 Explosive Dusts**

These are a concern of safety rather than health. Coal dust becomes explosive when small particles become and remain airborne. If an ignition source is encountered with sufficient methane in the area, then the ensuing methane ignition can lead to a catastrophic dust explosion (IARC, 1997, AIOH, 2009, and WHO, 1994).

#### **2.4.1.7 Nuisance Dusts**

Nuisance dust can be defined as dust that contains less than 1% quartz. Because of its low content of silicates, nuisance dust has been shown to have little adverse effect on the lungs. Any reaction that may occur from nuisance dust is potentially reversible. However, excessive concentrations of nuisance dust in the workplace may reduce visibility potentially causing accidents or injury, may cause unpleasant deposits in eyes, ears, and nasal passages, and may cause injury to the skin or mucous membranes by chemical or mechanical action (USDOL, 2008, and McPherson, 2009).

### **2.5 Types of Lung Disease**

## CHAPTER TWO

### Dust: Definitions, Deposition and Physiological Effects

---

#### 2.5.1 Pneumoconiosis

In general, the human respiratory system's physiological reaction to any inhaled particulate depends on many factors, with particle aerodynamic diameter being the main consideration relative to coal dust. Pneumoconiosis is the primary concern with coal dust (USDOL, 2008).

The term pneumoconiosis is a generic term for damage to cardio-respiratory organs caused by the inhalation of dust and effectively means dust in the lungs. It is defined by the International Labor Organization (ILO) as the accumulation of dust in the lungs and the tissue's reaction to its presence. The inhalation of coal dust, over a long period and at sufficient concentrations, can result in the formation of scar tissue and loss of elasticity, referred to as fibrosis. This reaction is termed pneumoconiosis (black lung) when linked to coal dust exposure (USDOL, 2008).

Pneumoconiosis occurs in two forms: simple Coal Workers Pneumoconiosis (CWP) and complicated CWP which leads to the condition of Progressive Massive Fibrosis (PMF). Over sufficiently long periods of exposure a build-up of retained dust occurs in the lung tissue in the form of soft plaques within the lung tissue. These can be observed as a small spot on chest x-rays (NCBI, 2012). Figure 2.11 shows a chest x-ray of simple pneumoconiosis in a coal workers lung. There are diffuse, small (2 to 4 mm each), light areas throughout both lungs. In the right upper lung (seen on the left side of the picture), there is a light area (measuring approximately 2 cm by 4 cm) with poorly defined borders, representing coalescence (merging together) of previously distinct light areas (NCBI, 2012).

## CHAPTER TWO

### Dust: Definitions, Deposition and Physiological Effects

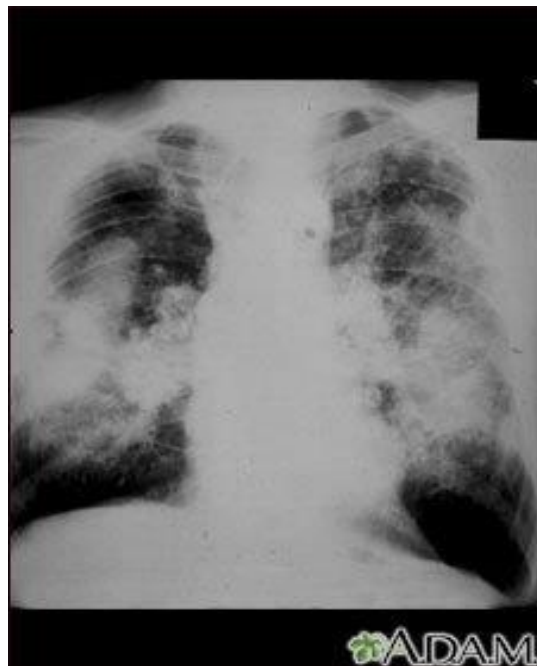
---



**Figure 2.11 X-ray Showing Simple Pneumoconiosis (NCBI, 2012)**

Figure 2.12 shows an X-ray of complicated pneumoconiosis. There are diffuse, massive light areas that run together in the upper and middle parts of both lungs.

These are superimposed on a background of small and poorly distinguishable light areas that are diffuse and located in both lungs (NCBI, 2012).



**Figure 2.12 X-ray Showing Complicated Pneumoconiosis (NCBI, 2012)**

## CHAPTER TWO

### Dust: Definitions, Deposition and Physiological Effects

---

Indications of CWP may not be revealed for some 10 to 15 years after initial exposure from employment in coal mines. Furthermore, the subjects may not be aware of any incapacity, or restrictions on lung function during that time. In more advanced cases, the opacities grow in size and number until they coalesce as seen in Figure 2.13. This is likely to be accompanied by fibrosis (McPherson, 2009).



**Figure 2.13 Healthy Lung and Lung with CWP (DHHS, 2002)**

### 2.5.2 Silicosis

Silicosis is a fibrosing disease of the lungs caused by the inhalation and retention of Respirable Crystalline Silica (RCS) produced during the cutting cycle of mining operations (DHHS, 2010). The early stages of the disease produce lung accumulations that may be observed on x-ray films similar to that seen in identified cases of pneumoconiosis detailed in 2.5.1 (McPherson, 2009). Silicosis is irreversible, progressive, incurable and at later stages disabling and eventually fatal (WHO, 1999).

Three clinical types or presentations of silicosis that can be produced from the inhalation and deposition of dusts containing respirable crystalline silica have been defined as:

- simple silicosis;
- complicated silicosis

## CHAPTER TWO

### Dust: Definitions, Deposition and Physiological Effects

---

- accelerated silicosis; and
- acute silicosis.

Once these conditions have developed, no known cure or medical treatment is available, no reversal of the condition will occur over time, and it has been identified that the effects worsen even though no further exposure to silica is experienced (USDOL, 2008, DHHS, 2010, McPherson, 2009, and WHO 1999).

#### 2.5.2.1 Simple Silicosis

Simple silicosis is the most common clinical presentation of the disease and results in fibrotic changes in the air exchange region of the lung that may occur after 10 to 30 years of inhalation of RCS. The fibrotic changes (like scars) are called silicotic lesions which are of a nodular appearance and these lesions increasingly affect the ability of the lung to exchange gases. Those changes in turn place extra stress on the cardiovascular system and reduce the body's ability to combat respiratory infections (USDOL, 2008, McPherson, 2009, WHO, 1999, and DHHS, 2002). Determining the exposure limit at which workers are at risk of developing simple silicosis is an extremely difficult task for a variety of reasons. These reasons include but are not limited to:

- lack of reliable past dust exposure information;
- insufficient medical surveillance information;
- individual susceptibility; and
- the role of other exposures such as smoking.

It is generally believed, however, that daily workplace exposures that exceed established exposure standards as detailed in this document can result in simple silicosis (USDOL, 2008).

The first symptom of silicosis is dyspnoea (difficult or laboured breathing and/or shortness of breath). This is first observed within the normal work activity or exercise and later as the lung function deteriorates, may be observed whilst resting or during

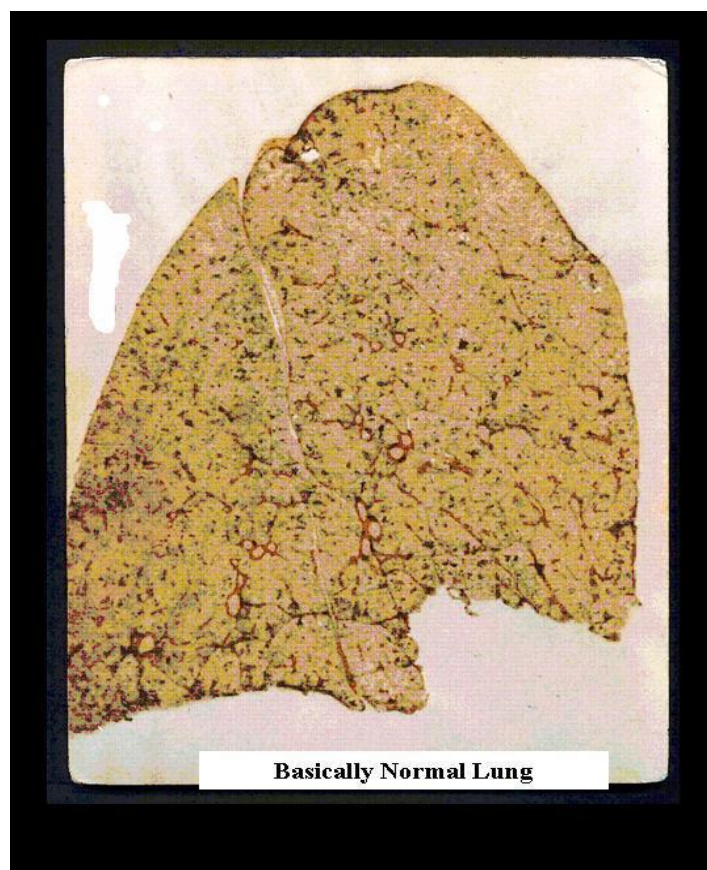
## CHAPTER TWO

### Dust: Definitions, Deposition and Physiological Effects

---

periods of no activity. Workers with simple silicosis are usually without any symptoms. If symptoms occur, they are typically limited to a chronic cough with phlegm (mucus) production and often get misdiagnosed as other ailments. It is also possible that there may be no shortness of breath or other symptoms and the disease may first be detected through an abnormal chest x-ray. The x-ray may show quite advanced silicosis with only minimal symptoms (DHHS, 2010, and USDOL 2002).

The fibrosis in simple silicosis occurs predominantly in the upper lung zones and appears on the chest x-ray as small discrete nodules (lesions) arranged in a birdshot pattern (USDOL, 2002). Figures 2.14 and 2.15 show a basically normal lung and a lung with simple silicosis.



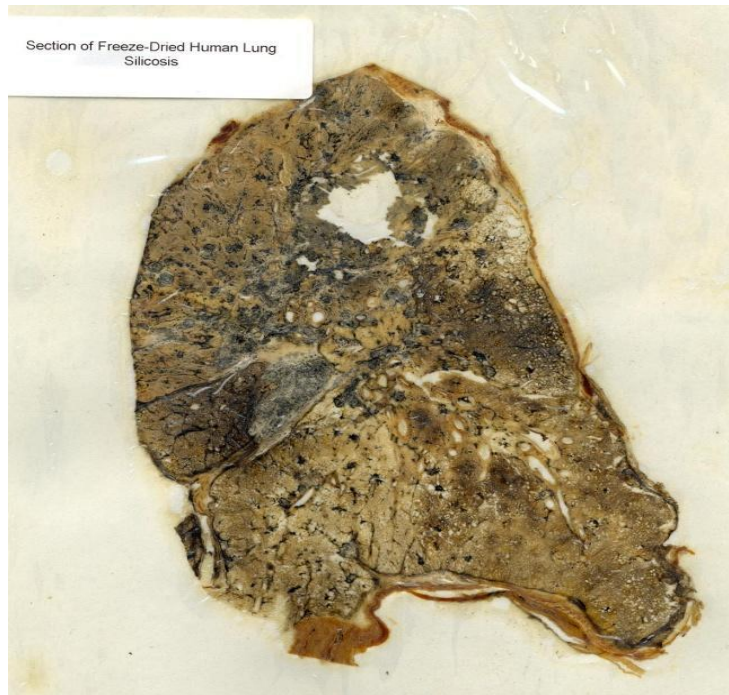
**Figure 2.14 Normal Lung (DHHS, 2002)**



## CHAPTER TWO

### Dust: Definitions, Deposition and Physiological Effects

---



**Figure 2.15 Simple Silicosis (DHHS, 2002)**

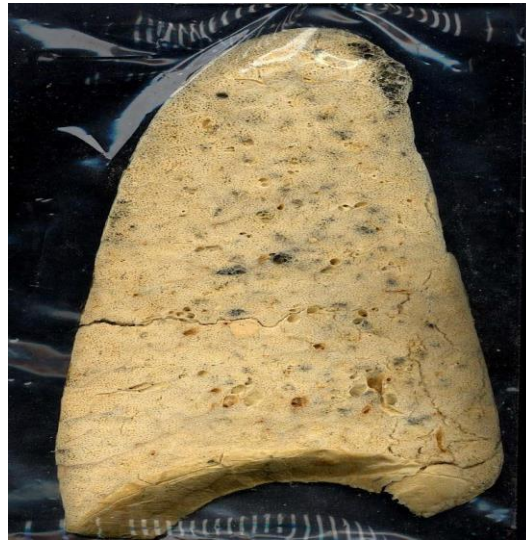
#### **2.5.2.2 Complicated Silicosis**

Complicated silicosis usually occurs after 10 or more years of exposure at relatively low concentrations of silica dust. The silicosis nodules increase in size and coalesce into large lesions usually greater than 1 cm in diameter. The conglomerate lesions may obliterate bronchi and vessels and cause marked distortion of lung structure and function. The disease results in progressive massive fibrosis (PMF). When progressive massive fibrosis occurs, the patient develops progressive respiratory symptoms from reduction in lung volume, distortion of bronchi, and bullous emphysema. The main symptom is shortness of breath which is related to a loss in lung volume. Figure 2.16 shows a healthy lung, and Figure 2.17 shows a lung with complicated silicosis. Complicated silicosis is progressive and ultimately disabling, potentially leading to cardio respiratory failure and possible death (AIOH, 2009, and USDOL, 2008).

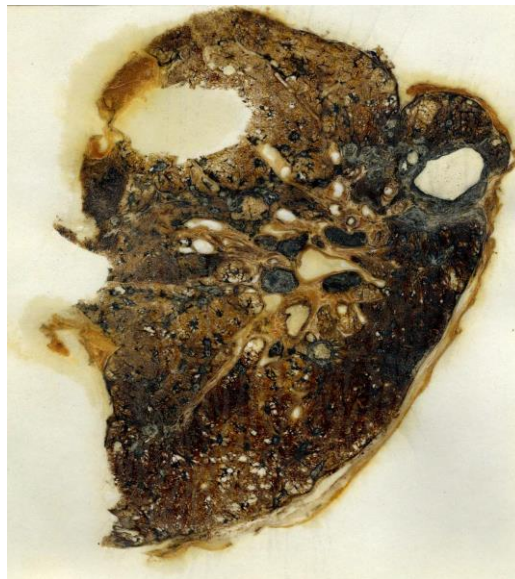
## CHAPTER TWO

### Dust: Definitions, Deposition and Physiological Effects

---



**Figure 2.16 Healthy Lung (DHHS, 2002)**



**Figure 2.17 Complicated Silicosis (DHHS, 2002)**

#### **2.5.2.3 Accelerated Silicosis**

Accelerated silicosis results from the inhalation of very high concentrations of respirable crystalline silica over a relatively short period, in the order of 5 to 10 years, whereas complicated silicosis may take 10 to 30 years to develop. Although accelerated silicosis develops in a pattern similar to that of complicated silicosis, the time from initial exposure to the onset of the disease is significantly shorter and the progression to complicated silicosis is more rapid. This form of the disease is life-

## **CHAPTER TWO**

### **Dust: Definitions, Deposition and Physiological Effects**

---

threatening, and death may occur as a result of insufficient levels of oxygen in the blood in as little as 10 years after exposure has occurred (USDOL, 2008, and AIOH 2009). It has been reported that the onset of silicosis has occurred amongst drill operators within a year of being exposed to air concentrations of silica 2000 times the accepted statutory exposure level (WHO, 1999).

#### **2.5.2.4 Acute Silicosis**

Acute Silicosis develops from the inhalation of high concentrations of RCS and is the most aggressive of the silicotic diseases. Acute silicosis develops over a very short period ranging from as little as a month to 4 or 5 years. Acute silicosis differs from complicated and accelerated silicosis in that the characteristic nodular pattern in the upper lung is absent with the x-ray's appearance instead being similar to that of diffuse ground glass. Symptoms of acute silicosis include cough, weight loss, and fatigue. This may progress rapidly to respiratory failure over a period of several months. Death occurs after a few months (USDOL, 2008, and AIOH, 2009).

#### **2.5.3 Silica and Lung Cancer**

In 1997, after re-evaluating the scientific literature on respirable crystalline silica, the World Health Organisation International Agency for Research on Cancer (WHOIARC) published a monograph that concluded that there is now sufficient evidence in humans that inhaled crystalline silica in the form of quartz from occupational sources can cause cancer (WHOIARC, 1997).

The WHOIARC working group, on the question of silica exposure and cancer risk in humans, found that several studies among the many reviewed were negative or equivocal. The studies also identified that the carcinogenicity of silica was not detected in all industrial operations. However, nine studies did identify an excessive risk for lung cancer in certain dust producing occupations. These dust producing occupations included mine workers, although coal-mine workers were not specifically identified. Increased lung cancer risk among these groups appears to be found only in those with exposure to high levels of crystalline silica (WHOIARC, 1997, AIOH, 2009, and WHO, 1994).

## **CHAPTER TWO**

### **Dust: Definitions, Deposition and Physiological Effects**

---

#### **2.6 Summary**

The health effects of worker exposure to respirable and inhalable dust are significant. Long term exposure can be at the worst fatal, and at the best debilitating. The deposition of inhaled or ingested particles in the human airway tract remains the same regardless of where the particles are generated resulting in severe physiological effects, often resulting in severe lung disorders and eventual death. With the identified increase in lung disease amongst US miners, the need to further understand respirable and inhalable dust generation behaviour before it is inhaled or ingested is becoming significantly more urgent.

**CHAPTER THREE - THE PRODUCTION OF  
RESPIRABLE AND INHALABLE DUST****3.1 Dust Production in Longwall Mining**

Respirable and Inhalable dust problems encountered in longwall mining can almost certainly be directly attributed to a lack of fundamental knowledge about the amounts and characteristics of airborne dust generated during the cutting cycle (Organiscak, *etal.*, 2003).

Mine dusts vary widely in shape. The simplest method of quantifying the size of a non-spherical particle is the projected area or equivalent geometric diameter as discussed in detail in Chapter 2. This is the diameter of a sphere that has the same projected area as the actual particle. Typical size ranges of some common items are given in Table 3.1.

**Table 3.1 Size Ranges of Common Particles (The Engineering Toolbox, 2012)**

<b>Particle</b>	<b>Particle Size (<i>microns, <math>\mu\text{m}</math></i>)</b>
dot (.)	615
Eye of a Needle	1230
Beach Sand	100 - 10000
Mist	70 - 350
Human Hair	60 - 600
Burning Wood	0.2 - 3
Anthrax	1 - 5
Carbon Black Dust	0.2 - 10
Coal Dust	1 - 100

In general, the size distribution within each range follows a lognormal curve. Particles do not become visible to the naked eye until they are more than 10  $\mu\text{m}$  equivalent diameter, therefore respirable dust cannot be seen. It must also be considered and understood that heavy visible concentrations of dust in a mine atmosphere produced

## **CHAPTER THREE**

### **The Production of Respirable and Inhalable Dust**

---

during the cutting cycle are accompanied by high levels of respirable and inhalable dust (McPherson, 2009).

Particle concentrations are traditionally expressed either as a number or as a mass concentration when measuring exposure levels. The number concentration of particles is the ratio of the number of particles in a given volume to the air volume. The particle mass concentration is defined as the ratio of mass of particles in a given volume to the air volume. The particle mass concentration can be determined by filtering a known volume of air and weighting the collected particles as detailed in Chapter 6. Particles mass concentration in coal mines ranges from 0.2 to 50 mg/m<sup>3</sup> (McPherson, 2009).

#### **3.1.1 Sources of Longwall Dust Generation**

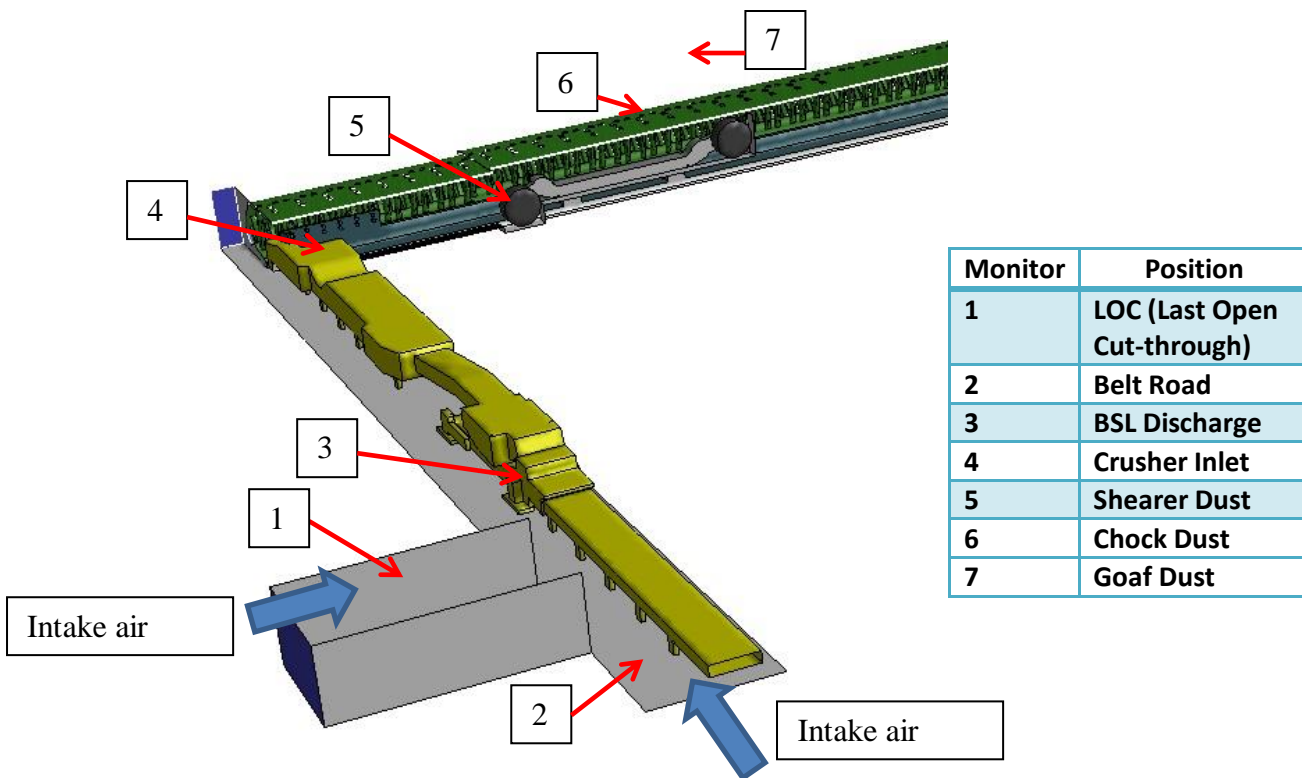
Irrespective of dust loads and exposure levels on any operating longwall, which are directly proportional to tonnages produced, longwall dust generation is produced from identical sources on each operating longwall. Each of these identified sources produce relatively the same percentage of dust as a proportion of total face dust in each instance.

Research from NIOSH has identified that there are 7 individual sources of dust generation on operating longwalls globally (Rider and Collinet, 2007). Longwall personnel can be exposed to harmful dust from these multiple dust generation sources including the last open cut-through (LOC), belt road, beam stage loader (BSL) discharge, crusher inlet, the shearer, chock advances and dust ingress from the goaf.

Figure 3.1 shows the location of each of these independent sources of dust generation.

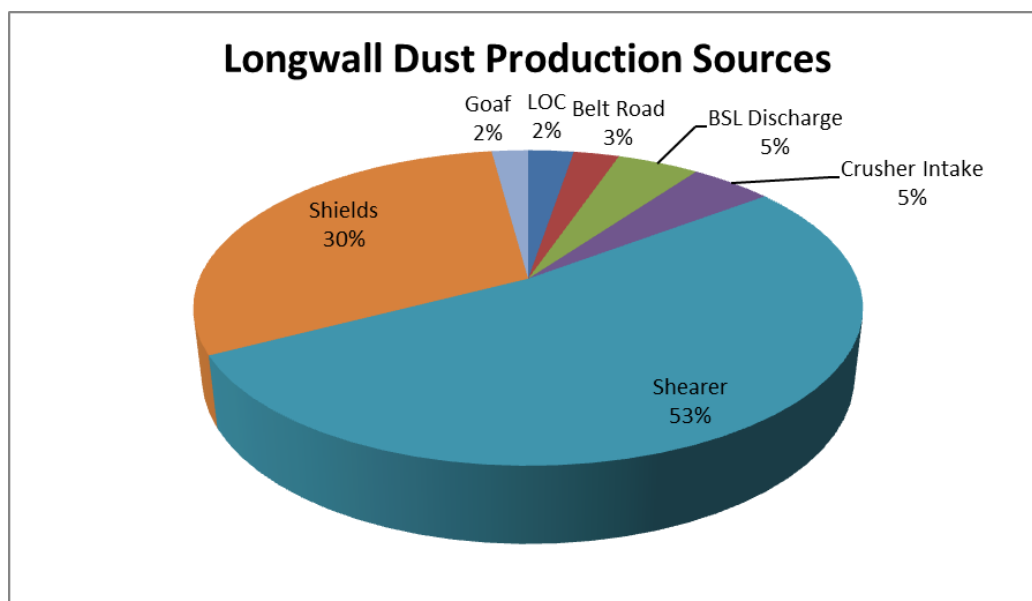
### CHAPTER THREE

#### The Production of Respirable and Inhalable Dust



**Figure 3.1 Sources of Dust Generation on Longwalls**

Figure 3.2 shows a chart of total face dust as a percentage generated from independent sources.



**Figure 3.2 Total Face Dust as a Percentage Generated from Independent Sources (NIOSH, 2003)**

## CHAPTER THREE

### The Production of Respirable and Inhalable Dust

---

NIOSH research has found that in excess of 80% of the total respirable and inhalable dust produced on an operating longwall is from the shearer and chocks. This thesis has measured the same dust production (NIOSH, *etal.*, 2003).

#### 3.1.1.1 The Last Open Cut-Through (LOC)

The LOC is one of two ventilation intakes for the longwall (Figure 3.2) and also the primary travel road in longwall mines. The transport road is often contaminated with high levels of respirable and inhalable dust as a result of transport activities to and from the longwall and outbye activities such as gas drilling, bolting or many other activities that occur in a mine in the primary transport road. Although the amounts of respirable and inhalable dust measured in the air are minimal, they add to the amount of dust entering the maingate area of the longwall cumulatively with the generated belt road dust and the BSL discharge dust. Figure 3.3 denotes a typical LOC.



**Figure 3.3 Typical Last Open Cut-Through**



## CHAPTER THREE

### The Production of Respirable and Inhalable Dust

---

#### 3.1.1.2 The Outbye Belt Road

The outbye belt road is the second of the two ventilation intakes and is contaminated with respirable and inhalable dust being drawn off the face coal being transported to the surface (Figure 3.2). As this coal gets drier, the intake ventilation draws more fines off the coal into the intake air which joins the intake roadway dust to enter the longwall. Figure 3.4 shows a typical conveyor in the belt road.



**Figure 3.4 Typical Outbye Belt Road**

#### 3.1.1.3 BSL Discharge

The BSL discharge contributes respirable and inhalable dust into the incoming ventilation as the coal that has been mined from the longwall, passes through the crusher and the BSL and is discharged onto the outbye belt for transport to the surface. The BSL discharge is approximately 900mm the outbye belt and dust

## CHAPTER THREE

### The Production of Respirable and Inhalable Dust

---

is produced as the coal transfers from the BSL discharge to the outbye belt. This dust is then picked up by the intake ventilation and added to the dust from the LOC and belt road and taken to the longwall face. Figure 3.5 denotes a typical BSL discharge configuration.



**Figure 3.5 Typical BSL Discharge**

#### **3.1.1.4 Crusher Inlet**

Respirable and inhalable dust is produced from the crusher inlet as a result of the coal being forced to change direction from the AFC 90<sup>0</sup> to enter the crusher mouth. The coal rubs against the BSL walls and is crushed out producing airborne particles. Further, the coal is taken onto the crusher by the AFC where it is crushed by rotating hammers that pressurise the crusher intake and force airborne particles out of the mouth of the crusher joining intake ventilation to the face. Figure 3.6 denotes a typical crusher intake including conveyor strips to reduce the dust entering the intake ventilation.

## CHAPTER THREE

### The Production of Respirable and Inhalable Dust

---



**Figure 3.6 Typical Crusher Intake**

#### **3.1.1.5 Shearer Generated Dust**

Respirable and inhalable dust generated from the shearer contributes in excess of 50% of the total amount of dust found on the longwall. This is simply a function of the shearer continually cutting and grinding the coal from the face. The dust is generated on the main cutting drum as the drum is in the raised position and spills into the walkway as the dust is entrained by the intake ventilation (Figure 3.7). When the drum is cutting the floor, the dust is again entrained into the intake ventilation and forced into the walkway (Figure 3.8).

## CHAPTER THREE

### The Production of Respirable and Inhalable Dust

---



**Figure 3.7 Dust Being Entrained into the Walkway from Raised Drum**



**Figure 3.8 Dust Entrained into Walkway from Drum Cutting Floor**

## CHAPTER THREE

### The Production of Respirable and Inhalable Dust

---

#### 3.1.1.6 Chock Generated Dust

Chock generated dust contributes approximately 30% of the total respirable and inhalable dust measured on a longwall face. This occurs as the chocks are moved forward as part of the typical cutting cycle on an operating longwall. The chocks move forward to advance the shearer through the longwall block and as the chock is pressurised or set against the longwall roof, coal is crushed between the top of the chock canopy and it is this crushed coal that falls into the walkway as the chock pushes forward. Figure 3.9 shows the dust generated from between the chocks as the chock is lowered and pushed forward. This dust is entrained into the intake ventilation and is swept along the face to the tailgate. Figure 3.10 shows the dust produced from between the chocks as the chock is set to the roof in the new position. This dust is also entrained into the intake ventilation and carried the length of the face. This dust production occurs when the shearer is heading down the face, so workers are fully exposed to the high concentrations of dust at this time.



**Figure 3.9 Dust from a Chock as it is Moved Forward**

## CHAPTER THREE

### The Production of Respirable and Inhalable Dust

---



**Figure 3.10 Dust from a Chock as it is Set to the Roof**

#### **3.1.1.7 Goaf Generated Dust**

Dust can be generated from the goaf due to goaf falls forcing dust laden air into the longwall walkway and adding to the face contamination. Over pressurisation of the goaf can also occur when intake ventilation bypasses the main gate chock and continues into the goaf. This air is then returned to the longwall face at some other point along the longwall, bringing with it contamination from the goaf.

### **3.2 Summary**

Dust generation from operating longwalls can be broken down into 7 individual sources. These sources are the last open cut-through, the belt road, the BSL discharge, the crusher intake, the shearer, the chocks and the goaf. The shearer and the chocks produce more than 80% of the total face dust. Engineering controls for these sources are discussed in detail in Chapter 4.

## **CHAPTER FOUR - DUST CONTROLS ON AUSTRALIAN LONGWALLS**

### **4.1 Introduction**

Control processes in place for the mitigation of dust vary from mine to mine, with each individual mine having a dust mitigation setup that is the most effective for their operation.

A typical dust control setup on a longwall includes the primary use of sprays as the first point of control. The sprays used vary as discussed, however, a typical spray setup would include solid or hollow cone sprays for the BSL discharge and crusher with a water pressure between 12 and 20 Bar and a flow rate of up to 35 lpm. The number and positioning of sprays will vary from mine to mine.

The shearer will have a series of drum sprays between 45 and 80 dependent on the drum type, usually supplied by the manufacturer, which consist of an orifice of between 1.2mm and 2mm, a flow rate of between 90 and 100 lpm and a pressure of 20 to 30 Bar.

Some mining operations utilise a shearer clearer which consists of a series of up to 10 sprays dependent on desired configuration. These sprays are usually a solid cone with an orifice diameter between 1.2 and 3mm and an operating flow of between 25 to 30 lpm and operating pressure of between 20 and 30 Bar.

For chock generated dust, solid cone sprays are positioned in the canopy. These sprays usually have up to a 4mm orifice, using 30 lpm at a pressure of between 10 and 20 Bar.

Ventilation is used when production increases to dilute airborne dust with removal from the face occurring much quicker as face quantities increase. However, higher ventilation quantities have higher velocities and this higher velocity can cause settled dust to become airborne, potentially adding to dust levels. Some mines also employ

## **CHAPTER FOUR**

### **Dust Control On Australian Longwalls**

---

ventilation curtains and brattice wings to modify the behaviour of the ventilation to reduce the amount of air going passed the maingate chock, over pressurising the goaf and returning somewhere further along the face with contaminated air.

The industry has been using statutory dust measurements in underground coal mines conducted by both SIMTARS and Coal Services rely on AS 2985 for respirable size dust particles, and AS 3640 for inhalable size dust particles. The majority of dust sampling to date has been done with cyclone separation and collection of the sized particles for weighing, generally over the period of a full shift.

Although this method provides an accurate measurement for the total dust exposure for the period sampled, it does not always accurately reflect the source, quantity and timing of respirable dust entering the longwall from different sources, which presents difficulties in determining the relative effectiveness of the different control technologies in use.

## **4.2 Dust Mitigation Controls Used on Australian Longwalls**

### **4.2.1 Controlling Dust on Intake Roadways**

Water application to the mine travel roads is crucial to control respirable dust in the intake roadway. Operators must be diligent in monitoring moisture content of the dust along intake roadways, especially with the increased amount of air traveling toward the face and during winter months. This air amplifies the potential for the roadways to dry out more quickly. The moisture content of the transport road should be approximately 10% (Organiscak and Reed, 2004). Hydroscopic compounds such as calcium, magnesium chloride, hydrated lime, and sodium silicates increase roadway surface moisture by extracting moisture from the air. Applications of these materials will help maintain the moisture content of the travel road surface (Organiscak, *etal.*, 2003).

Surfactants such as soaps and detergents dissolve in water and can be beneficial in maintaining the proper moisture content of the intake roadways. Surfactants decrease



## CHAPTER FOUR

### Dust Control On Australian Longwalls

---

the surface tension of water, which allows the available moisture to wet more particles per unit volume (Organiscak, *etal.*, 2003).

Whilst these controls will offer a possible benefit in reducing the amount of respirable and inhalable dust produced from vehicle movement entering the longwall, little data has been collected to quantify the actual amount of dust removed by this form of control.

Application of the control can be restricted by the condition of the road, which in underground coal mining can deteriorate in a very short period of time and requires significant resources to maintain the integrity of the road to allow controls to be continually applied. Another problem with this control is the amount of water, salt or surfactant need to ensure the roadway remains moist. In many underground mining applications, this would be restrictive in terms of cost per tonne to not only purchase the control, but the cost of application will have a significant effect on resources.

#### **4.2.2 Controlling Dust from the Outbye Belt**

Dual intake air from the outbye belt will allow the delivery of more air to the face, providing the potential for better dust and methane dilution. Recent longwall surveys in the USA showed that about 40% of the operations were using belt entry air (Rider and Colinet, 2007). Compliance data analysed by MSHA showed that mines using belt air to ventilate work areas did not have significantly different respirable dust levels at the last open cut-through when compared to the mines not using belt air (MSHA, 1989). Further, studies conducted by the U.S. Bureau of Mine indicated that any potential addition to dust levels at the longwall face from the belt entry seems to be mitigated as a result of the increased dilution that can be obtained with additional air brought up the belt entry (Jankowski and Colinet, 2000). However, the potential for dust from the belt entry to contaminate the face area has increased in recent years because the quantity of coal being transported by the belt continues to increase.

## CHAPTER FOUR

### Dust Control On Australian Longwalls

---

Current outbye belt controls focus on properly maintaining the belts to keep respirable dust levels low along the belt entry. Missing rollers, belt slippage and worn belts can cause belt misalignment and create spillage (Organiscak, *etal.*, 1986). Given the increases in the quantity of coal being transported on the outbye belt, operators must be diligent in their efforts to properly maintain the existing belt entry dust suppression controls to keep fugitive dust from being entrained and carried by the ventilation airstream to the face area.

If the coal is wetted adequately at the face, less dust will be created during transport at the transfer points. However, with the substantial increase in airflow in the belt entry, the moisture may evaporate and rewetting of the coal may be necessary at multiple intervals along the belt. Flat-fan sprays and full-cone nozzles are typically used for coal wetting along the belt. Water application usually ranges from 30 to 45 lpm at operating pressures of between 1000 to 1700 kPa.

Scraping and washing of the belt play an important role in reducing the amount of dust generated by the conveyor belt (Kissell and Stachulak, 2003). Material that adheres to the belt is subject to crushing at the head and tail roller. Often this material dries out and becomes airborne as it passes over the return idlers. The top and bottom of the return belt should be cleaned with spring-loaded or counterweighted scrapers. A low-quantity water spray may be necessary to moisten the belt slightly and complement the belt scrapers. Previous studies have shown that water sprays in conjunction with belt scrapers significantly reduced airborne respirable dust levels (Baig, *etal.*, 1994), however, little quantifiable information is available to define the types of sprays, water pressure, water flow and spray placement that have the most impact on reducing this dust, nor which type of scraper has the greatest impact on reducing this dust.

#### **4.2.3 Crusher and BSL Dust Control**

According to Rutherford (2003), there is no universal dust suppression process or technique in Australian underground coal mines for the BSL and crusher to mitigate

## CHAPTER FOUR

### Dust Control On Australian Longwalls

---

produced dust. Rutherford found that dust generation is not generally considered at the time of purchase and problems are only detected after operations commence. Modifications are then difficult to make and redesign is expensive and sometimes ineffective and may take many changes to become effective.

Rutherford's research also highlighted the poor knowledge by the industry regarding the equipment, the effect on dust of the equipment and differences in operating effectiveness at different mines (Rutherford, 2003).

A typical crusher and BSL are fully enclosed, have conveyor belting at the crusher intake, one or two more strips before the hammers and some form of sealing or skirts on the BSL discharge to the outbye belt.

Figure 4.1 shows the conveyor belt on the intake to the crusher at the maingate.



**Figure 4.1 Conveyor Belt on the Intake to the Crusher**

Figure 4.2 shows the conveyor belt strips inside the crusher before the hammers.



**Figure 4.2 Conveyor Belt Strips inside the Crusher before the Hammers**

Figure 4.3 shows a typical skirting arrangement for the coal discharge onto the outbye belt.



**Figure 4.3 Typical Skirting Arrangement for the Coal Discharge onto the Outbye Belt**

## CHAPTER FOUR

### Dust Control On Australian Longwalls

---

Crusher and BSL sprays are typically used at the entrance to the crusher, at the discharge area and at the belt transfer area. Although there are many variations to the spray type used at individual mines, the typical spray is a full cone spray, usually in a row of three inside the crusher, with a row of spray between each of the conveyor skirts. The sprays traditionally use 35-45 lpm each at a pressure of 12 to 20 Bar.

Some mining applications have sprays on the transfer from the face AFC to the crusher intake and these are usually flat fan sprays designed to stop the dust billowing into the intake air. Figure 4.4 shows a typical spray setup to suppress dust from the face to crusher intake.



**Figure 4.4 Typical Spray Setup to Suppress Dust from the Face to Crusher Intake**

Figure 4.5 shows the typical hollow cone sprays inside the crusher in two rows of three between the conveyor skirts. It should be noted that the sprays are installed at approximately 45 degrees toward the hammer.



**Figure 4.5 Typical Hollow Cone Sprays inside the Crusher**

Figure 4.6 shows the typical spray setup inside the discharge to the belt.



**Figure 4.6 Typical Spray Setup inside the BSL Discharge**

## CHAPTER FOUR

### Dust Control On Australian Longwalls

---

Rutherford (2003) noted that although his research was not conclusive, it did point to the need to install dust extractors on most longwalls where coal volumes peak at the BSL volume.

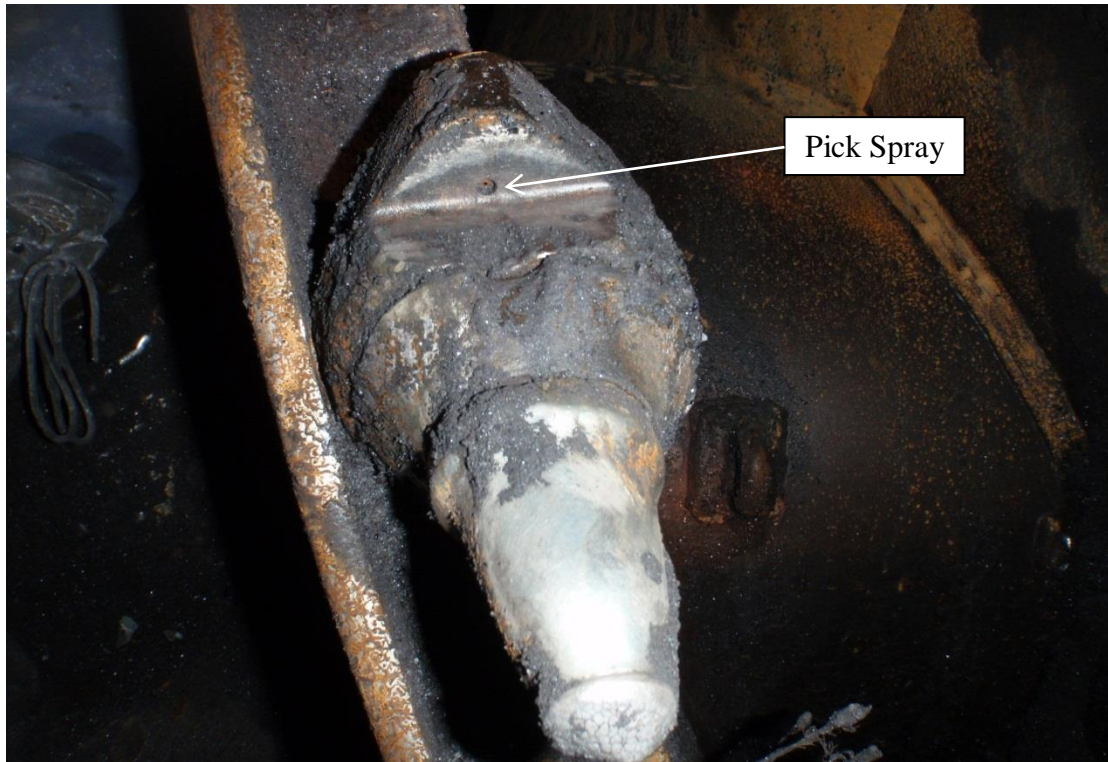
Figure 4.7 shows a typical electric drive dust extractor fitted to a BSL.



**Figure 4.7 Typical Electric Drive Dust Scrubber Fitted to a BSL**

#### 4.2.4 Controlling Shearer Dust

Drum mounted water sprays are the most commonly first point dust suppression process on the shearer cutting drum. The sprays are pointed directly at the pick point of coal fracture and add moisture to minimize dust liberation. The pick sprays are also vital for the mitigation of frictional ignition as the pick strikes the coal. Optimum pressure to the sprays is usually 20-30 Bar, the sprays are typically full cone or solid stream spray pattern and the number of sprays per drum ranges between 35-90. It should be noted that drum pressures and flows vary greatly from mine to mine. Figure 4.8 shows the location of the pick spray behind the pick and Figure 4.9 shows the typical spray insert used.



**Figure 4.8 Pick Spray behind the Pick on the Shearer Drum**



**Figure 4.9 Typical Spray Insert in Drum Sprays**



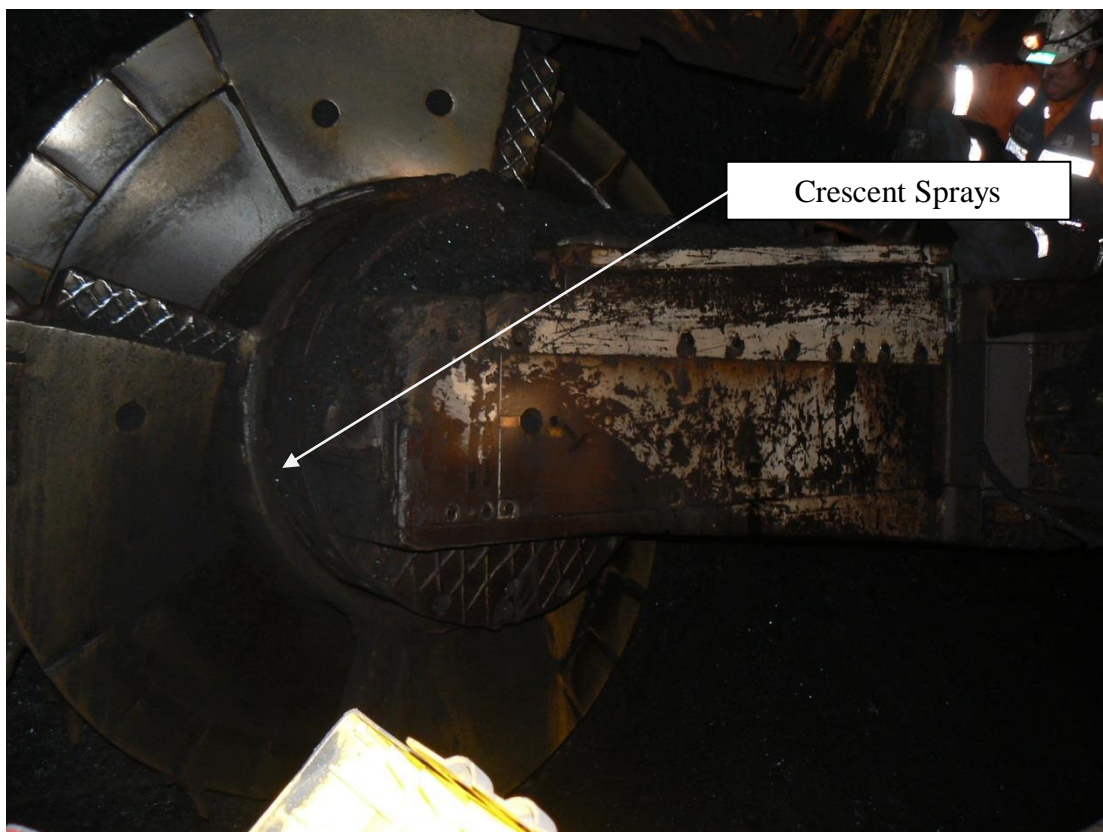
## CHAPTER FOUR

### Dust Control On Australian Longwalls

---

Cutting drum maintenance is critical to ensure the minimisation of dust liberation from the cutting pick. Bits with large carbon inserts and a smooth transition between shank and carbide are supposed to reduce dust levels, however; quantifiable testing results are not available to support this. Replacing damaged, worn or missing bits cannot be over-emphasized as dull bits result in shallow cutting and greatly increases dust generation.

Crescent Sprays are another method to potentially reduce shearer generated dust. They are typically located on the top and end of ranging arms with sprays oriented toward face. There are typically 8–10 hollow cone sprays with an operating pressure of between 12-20 Bar. The sprays on the end of ranging arm are typically oriented into the face airflow however; these can create turbulence that forces dust toward the walkway. Figure 4.10 shows a typical crescent spray setup on a maingate drum.



**Figure 4.10 Typical Crescent Spray Setup**

Shearer mounted sprays are often utilised for dust suppression and may include a shearer clearer designed to induce airflow and dust toward face or spray manifolds

## CHAPTER FOUR

### Dust Control On Australian Longwalls

---

positioned between the drum walkway. Both are designed to promote movement of dust-laden air close to the face and prevent migration toward the walkway. They are typically oriented with airflow and positioned on the maingate side of the shearer. Figure 4.11 shows a typical shearer clearer setup on a maingate arm and Figure 4.12 shows a spray manifold positioned on the maingate arm.



**Figure 4.11 Typical Shearer Clearer Setup**



**Figure 4.12 Spray Manifold Positioned on the Maingate Arm**

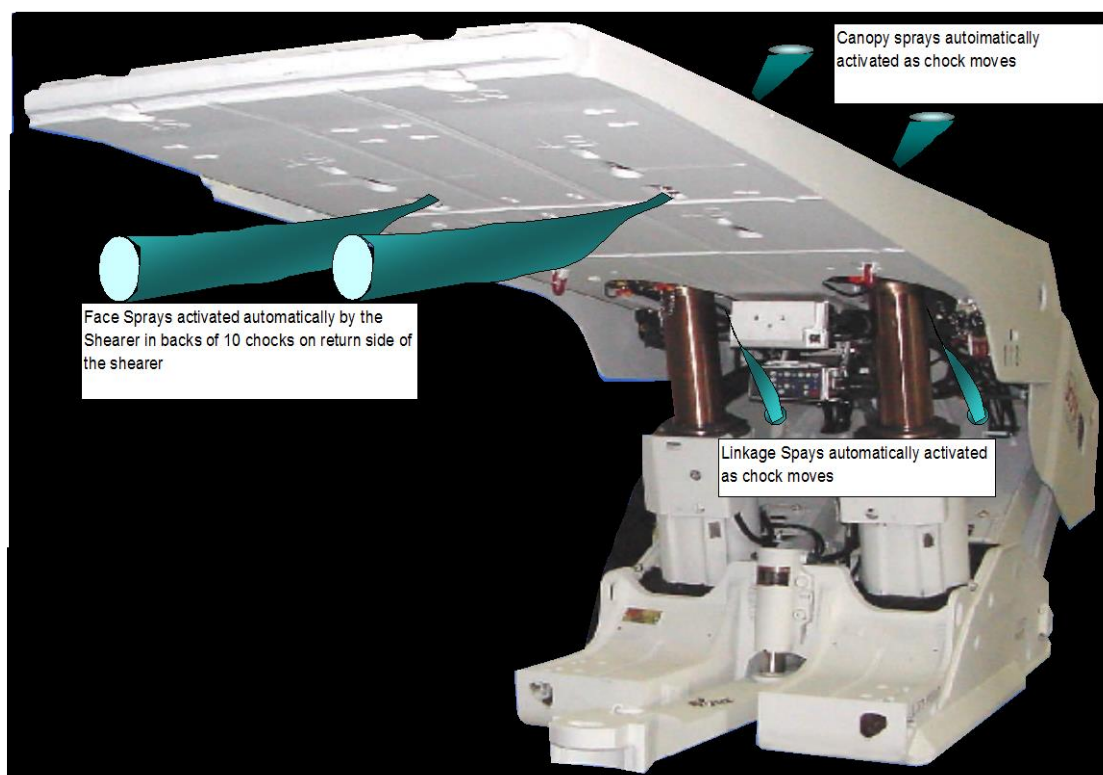
The latest product development for the mitigation of shearer generated dust is a shearer scrubber that has shown in independent testing to remove up to 76% of dust from the shearer operator's position. Figure 4.13 shows the shearer scrubber.



**Figure 4.13 Shearer Scrubber**

### 4.2.5 Controlling Chock Dust

Canopy-mounted sprays are typically employed in an attempt to minimise the dust produced during chock movement. They are typically placed on top of the chocks and are designed to activate as the chock is lowered and kept on until the chock is reset. Although the sprays are available in many mining operations, they are typically inoperable as they are extremely hard to maintain. Figure 4.14 shows the positioning of canopy sprays.



**Figure 4.14 Canopy Sprays**

In other applications, chock sprays can be fitted to the underside of the canopies, designed to activate when the shearer passes or during chock movement. These are also inoperable in many applications due to maintenance and the issue with wetting operators. Figure 4.15 shows a typical canopy spray.

## CHAPTER FOUR

### Dust Control On Australian Longwalls

---



**Figure 4.15 Typical Canopy Spray**

A recent development in under canopy sprays has been the development of a water mist venturi spray. The water mist venturi spray has been designed to be installed on the underside of the canopies similar to other spray configurations. The difference with this spray design has been the introduction of compressed air to further mist the water droplets thus creating smaller particles to increase agglomeration of the dust particles.

The water venturi sprays formed part of this thesis testing with the results discussed further in Chapters 8.7, 8.8 and 8.10.

Figures 4.16 and 4.17 show the installed venturi sprays operating at the BSL maingate and chock 5 respectively.



**Figure 4.16 Venturi Spray Installed on BSL Maingate**



**Figure 4.17 Venturi Sprays Installed at Chock # 5.**

## **CHAPTER FOUR**

### Dust Control On Australian Longwalls

---

#### **4.3 Summary**

Installed engineering controls are designed to mitigate respirable and inhalable dust, thus reducing the potential exposure of workers to the harmful dust. Different mines have different controls, usually installed based on experience and industry standards. Little or no quantifiable data exists to ascertain which controls actually remove the most respirable and inhalable dust, or those which actually create more dust. The results of installed engineering control testing are detailed in Chapter 8 and these results are used in the determination of the best practice engineering controls as detailed in Chapter 9.

**CHAPTER FIVE - CURRENT AUSTRALIAN AND USA  
DUST MONITORING PRACTICES****5.1 Introduction**

Questions relating to the validity and subsequent suitability of the current dust sampling methodologies utilised in Australia and the USA have recently come under scrutiny. The reason for this scrutiny is that there has been a significant increase in Coal Workers' Pneumoconiosis (CWP) in the USA over the last few years despite recorded conformance to exposure level legislation, and the opinion by many in the underground coal mining industry in Australia that the current testing regime tells them very little about the actual operational production of dust on the longwall face in relation to where it is produced, how much is produced or how efficient installed controls are at preventing this dust from entering the atmosphere.

Evaluation of a workplace is primarily undertaken to establish if the workplace environment is safe for employees to perform their normal duties. Occupational hygiene has been an integral part of the mining industry for centuries; however its importance has grown with developments in mechanisation and rising community expectations of better occupational health.

Production from longwall mining in Australia has increased remarkably over the last several years. This increased productivity has meant that more dust is being produced and controlling respirable and inhalable dust continues to present the greatest ongoing challenge for coal mine operators<sup>1</sup>. A recent report by the director of mine safety operations branch of Industry & Investment NSW has found that there is an increasing level of dust being ingested by coal miners in New South Wales, potentially leading to long-term health problems (ILN, 2010). This increased exposure level for underground workers can be directly attributed to the increase in coal production and the continued development of

---

<sup>1</sup> The US EPA describes inhalable dust as that size fraction of dust which enters the body, but is trapped in the nose, throat, and upper respiratory tract. The median aerodynamic diameter of this dust is about 10 µm.



## CHAPTER FIVE

### Current Australian and USA Dust Monitoring Practices

---

medium and thick seam mines in Australia which allow the installation of bigger and more productive longwall equipment.

Fugitive dust on longwalls has always been an issue of concern for production, safety and the health of workers in the underground coal mining industry both in Australia and globally. Longwall personnel can be exposed to harmful dust from multiple dust generation sources including, but not limited to: intake entry, belt entry, stageloader/crusher, shearer, chock advance and dust ingress from falling goaf or over pressurisation of the goaf. With the increase in production created from the advancement in longwall equipment, dust loads have also increased and this has resulted in an increase in exposure levels to personnel.

Studies by NIOSH in the USA have shown that prolonged exposure to excessive levels of airborne respirable coal dust can lead to Coal Workers' Pneumoconiosis (CWP), Progressive Massive Fibrosis (PMF), and Chronic Obstructive Pulmonary Disease (COPD). These diseases are irreversible and can be debilitating, progressive, and potentially fatal (DHHS, 2002). The continued occurrence of CWP in underground coal mine workers and the magnitude of respirable and inhalable dust overexposures in longwall mining occupations illustrate the need for the mining industry to improve existing dust control technology on longwalls not only the USA, but Australia as well to prevent the incidence of lung diseases from occurring.

Dust sampling in Australian coal mines is carried out with cyclone separation and collection of the sized particles for weighing, generally over the period of a full shift to measure personal exposure levels to airborne contaminants of employees. This testing methodology is described in AS2985 Workplace Atmospheres - Method for sampling and gravimetric determination of respirable dust and AS3640 Workplace atmospheres - Method for sampling and gravimetric determination of inhalable dust.

The long standing practice in underground coal mines has been to collect samples from crib room to crib room and for a minimum period of 5 hours. This is to avoid a number of practical difficulties in collecting samples during travel. Research

## CHAPTER FIVE

### Current Australian and USA Dust Monitoring Practices

---

undertaken indicates that crib room to crib room sampling of 0.12 milligrams, at the higher flow rate and with a travelling time conversion factor applied, corresponds to a limit of 0.1 milligrams for portal to portal sampling. The end result is that for underground mines the working limit for quartz is effectively unchanged and remains at a level where silicosis has not been observed in the coal mining workforce. The change in limit for respirable dust, other than quartz-containing dust, is to take into account the higher sampling flow rate now required by AS2985-2004.

The current testing regime in Australia provides the mine tested with a single Figure for respirable dust exposure levels for 5 samples taken over a minimum of 4 hours during a production shift. These Figures only provide information relating to the exposure levels of the person sampled, relative to the 300mm breathing zone described in AS2985, and does not provide any feedback on where the dust has come from or any other information that would allow the mine site to implement improvements in mitigation procedures should a non-compliance, or failure to Statutory regulations occur.

The problem goes deeper for the testing regime in the USA as a direct result of a known increase in CWP identifying 1000 new cases per year since 1984 and the recent findings of the UBB disaster where autopsies revealed seventeen of the 24 victims' autopsies (or 71%) had CWP. This compares with the national prevalence rate for CWP among active underground miners in the USA which is 3.2%, and the rate in West Virginia which is 7.6%.

Further, of the 17 UBB victims with CWP, five of them had less than 10 years of experience as coal miners, while nine had more than 30 years of mining experience. At least four of the 17 worked almost exclusively at UBB. All but one of the 17 victims with CWP began working in the mines after the 2.0 milligram coal mine dust limit was put in affect in 1973. This was an exposure limit that was believed at the time sufficient to prevent black lung disease. This exposure limit has since been determined ineffective to protecting miners' health (McAteer, 2010).

## **CHAPTER FIVE**

### **Current Australian and USA Dust Monitoring Practices**

---

This chapter will detail current methods for respirable and inhalable dust sampling and discuss the limitations involved.

#### **5.2 Current Australian Dust Monitoring Practices**

AS2985 and AS3640 clearly define the process to be used to determine personal exposure levels in coal mines.

According to Coal Services respirable dust testing analysis, there have been 18,900 respirable dust samples, including re sampling, taken in the period 1984-2007 (Mace, 2008). Of these samples, it has been reported that there have been 1200 samples the exposure limit for respirable dust, which represents less than 6.5% of total samples taken (Mace, 2008). From these sample results, it is clear that the current controls for mitigating longwall dust exposure levels is highly successful in the removal of respirable dust.

New South Wales government testing of inhalable coal dust in the state's longwall mines has found more than a third of the samples taken exceeded the  $10\text{mg}/\text{m}^3$  limit (ILN, 2010). A  $10\text{mg}/\text{m}^3$  limit on inhalable dust in coal operations was imposed in December 2007 from notice provided under the Coal Mine Health and Safety Act.

In an article dated Tuesday, 9 March 2010 in the International Longwall News, Rob Regan, Director of the Mine Safety Operations Branch under the Department of Industry and Investment, issued a safety alert to all mines that have been advised to identify and control risks in relation to excessive failures of inhalable dust exposure levels (ILN, 2010).

According to the article, the results of coal dust testing in the Newcastle region revealed that 44 out of 104 samples taken in longwall operations exceeded  $10\text{mg}/\text{m}^3$  which is a failure rate of 42.3%. 50 of the 95 longwall samples in the Hunter region, which is more than half at 52.6%, failed the government limit.

None of the 29 longwall samples in the Western region failed while 25.3% of the

## **CHAPTER FIVE**

### Current Australian and USA Dust Monitoring Practices

---

samples in the Southern District exceeded the limit. Examining the sampling reports, Regan outlined the following likely causes of high coal dust levels:

- inadequate ventilation;
- inadequate water or dust control;
- poor operator positioning;
- damaged equipment; or
- poor work practices.

Regan further suggests the following strategies to combat the problem:

- isolation or capture of dust at source via sealing of transfer points, BSL, and crushers;
- operating water sprays at appropriate locations and as near as possible to the point of breakage with sufficient water volumes, pressure and correct sizing of water jets/droplets;
- ventilation of the correct quantities and at the right location;
- advance ventilation ducting/brattice to mine ventilation standard;
- regular maintenance of dust suppression equipment;
- operator positioning, job rotation and automation;
- control of dust levels along travelling roads; and
- respiratory protection by personal protective equipment.

In contrast to the success of the current longwall dust controls in mitigating respirable dust, the analysed results of inhalable dust exposure levels, it is clear that the current longwall controls for mitigating inhalable dust are not successful.

#### **5.2.1 Coal Services NSW Statutory Dust Monitoring**

The Coal Services Health (formerly the Joint Coal Board and JCB Health) dust monitoring service is quality accredited and has been the sole organization involved with personal dust monitoring in the NSW coal industry since the current regulations

## **CHAPTER FIVE**

### **Current Australian and USA Dust Monitoring Practices**

---

were gazetted in March 1984. The service has the total support and acceptance of both management and unions (Cram, 2003).

The specified limit for respirable dust other than quartz-containing dust, is 3mg of respirable dust/m<sup>3</sup> of air sampled. The specified limit for quartz-containing dust is 0.15mg of respirable quartz/m<sup>3</sup> of air sampled (CMRA, 1982).

In NSW sample collection commences at the time of leaving the crib room at the start of the shift and ceases on arrival at the crib room at the end of the shift. The sampling period, if practicable should be not less than five hours (CMRA, 1982).

While it is the responsibility of mine management to meet the frequency of sampling required by the CMRA the Coal Services Health monitoring programs are structured in such a manner that management's obligations are fulfilled were possible.

The integrity of results is guaranteed by a Coal Services Health employee present in the workplace during the sampling shift recording such information as ventilation quantities, blocked sprays, operator location, water pressures or anything which may affect results. Results are used solely to identify problem areas which may exist and are not used at any time for punitive measures. Where areas of high dust concentrations are found to exist efforts are directed to these areas in order to rectify the problems. These efforts in many cases involve Management, Union and Coal Services Health initiatives.

Results of the sampling are forwarded to the Colliery Manager, Senior Government Inspector of Coal Mines, United Mineworkers District Check Inspector and included in the Coal Services Health dust database.

If the result of any sample exceeds the specified limit a re-sample must be taken within seven working days in similar circumstances to those existing when the sample was collected. If the resample still exceeds the specified limit the District Inspector of Coal Mines may, in writing, direct the Colliery Manager to carry out additional

## CHAPTER FIVE

### Current Australian and USA Dust Monitoring Practices

---

procedures to reduce the concentration of airborne dust (NSW Govt. 1999).” (Cram 2003)

The following information is extracted from the document titled:

“Airborne Dust in Coal Mines Respirable Dust and Quartz Inhalable Dust Coal Services Pty Ltd 2008”

*Sampling: What method is used to determine the respirable dust concentration of air in working places?*

The approved sampling method adopted in the New South Wales coal industry is personal gravimetric sampling. In this method, respirable dust is collected from the breathing air very close to the nose and mouth of a mine worker and the amount of dust is then measured by weighing. The weight of fine dust drawn into the lungs gives the most accurate prediction of the likelihood of developing pneumoconiosis (being dusted). The samples are taken by means of a small battery powered pump worn by the mine worker. The pump is connected with a piece of plastic hosing to a sampling unit (or cyclone) that is clipped to the individual’s shirt. A steady stream of air is drawn through the sampling unit where the coarse dust is first removed and only the very fine respirable dust is collected on a filter and weighed.

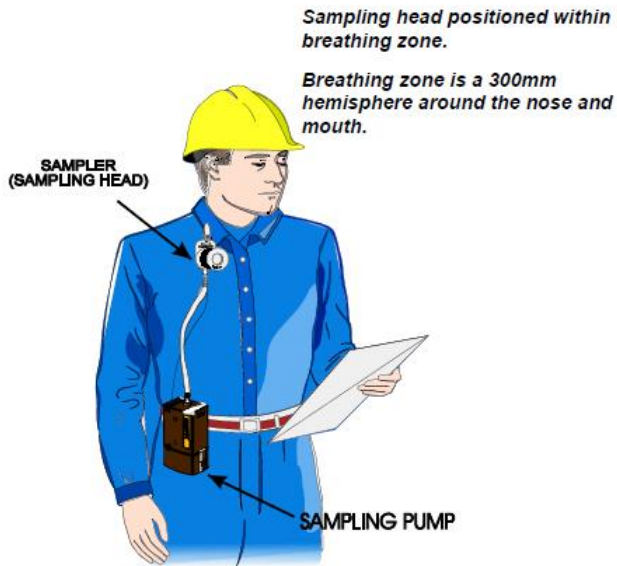
*What are the purposes of dust sampling?*

A comprehensive monitoring programme is continually being carried out to determine whether dust levels at every coal mine are kept the approved limits and to protect the long term health of mine workers.

## CHAPTER FIVE

### Current Australian and USA Dust Monitoring Practices

---



*What working places are sampled for respirable dust?*

As per the *NSW Coal Mine Health & Safety Regulation 2006*, mine workers are sampled regularly. For longwall faces, sampling is carried out at intervals not exceeding 6 months on each producing shift. For continuous miner panels, sampling is carried out at intervals not exceeding 12 months on each producing shift. Other underground working places, open cuts, coal preparation plants, crusher and loading stations are all sampled at intervals not exceeding 12 months on only one production shift.

*What is done with the dust results?*

Copies of all results are sent to the Mine Operator, Inspector of Coal Mines and Industry Check Inspector. Following a failed result, the Mine Manager informs the person who was sampled and there is an obligation under the *Coal Mine Health & Safety Act Regulation 2006* to take action to correct the situation. Coal Services, through the Standing Dust Committee (SDC,) also maintains an overview of the results of the dust sampling programme in mines and where necessary advises the mine management on how to improve the situation. This SDC recommends the display of all results on the mine notice boards.

## CHAPTER FIVE

### Current Australian and USA Dust Monitoring Practices

---

*Should the exposure limits be less for extended shifts?*

The current exposure limits for dust and quartz are based on a 40 hour week (8 hour shifts 5 days a week) over a 40 year working life. For working weeks greater than 40 hours therefore the exposure limit needs to be lower. As a general rule the exposure limit can be adjusted by a factor calculated from the ratio of weekly exposure in a normal work cycle to the average weekly exposure in the extended cycle. For more detailed information on this matter please refer to the Coal Services Health & Safety Trust research project on Extended Shift Exposure Limit Adjustment Factors for Coal Mine Dusts. Website [www.coalservices.hstrust.com.au/](http://www.coalservices.hstrust.com.au/) or contact Coal Services Health & Safety Trust by Email [trust@coalservices.com.au](mailto:trust@coalservices.com.au)

*What happens to the results if the person sampled is exposed to one very dusty task for a short time and no dust for the remainder of their shift?*

The method of dust sampling is designed to give the average result for the duration of the shift taking into account periods of high and low exposure dust. The dilution effect of a worker being exposed to a non-contaminated atmosphere following a short but high exposure would therefore be beneficial to the worker such as job rotation during the shift. One of the key factors involved in the onset of lung dust disease is the total amount of coal dust or quartz that a person has inhaled during their working life. It is not based on whether the person has been exposed to a high level of dust in a single event on one part of a shift or due to a particular mining method.

*What method is used to determine the inhalable dust concentration?*

The gravimetric method used for respirable dust sampling is also used for inhalable dust sampling. The main difference is the sampling head which collects dust particles 100 microns rather than only the very small respirable dust particles.



## CHAPTER FIVE

### Current Australian and USA Dust Monitoring Practices

---

#### Dust Particle Size Comparison



*What is the location and frequency of sampling inhalable dust?*

As per the NSW *Coal Mine Health & Safety Regulation 2006*, mine workers are sampled regularly. For longwall faces, sampling is carried out on each producing shift at intervals not exceeding 12 months. For continuous miner panels, any part of a mine where cement products are being applied, other underground places including crusher stations, open cuts and coal preparation plants are all sampled on one shift only at intervals not exceeding 12 months.

*Exposure Standards: What is the respirable dust exposure limit in NSW coal mine?*

As you will remember, the dangerous dust consists of those very small particles (less than 5 microns in size) which can penetrate deep into your lungs. This is called respirable dust. The limit under the *Coal Mine Health & Safety Act 2002 and Regulation 2006* 1 is based on the weight of respirable dust in the air. It is the concentration in milligrams of respirable dust per cubic metre (abbreviated to mg/m<sup>3</sup>) of air collected in the breathing zone (not inside respirators or airstream helmets) of mine workers during their working shift.

*The concentration of respirable dust should not exceed 2.5 mg/m<sup>3</sup> over the sampling period. The concentration of respirable quartz dust should not exceed 0.12 mg/m<sup>3</sup> in underground coal mines and not exceed 0.1 mg/m<sup>3</sup> in open cut coal mines and the surface parts of underground coal mines.*

## CHAPTER FIVE

### Current Australian and USA Dust Monitoring Practices

---

*How were the limits determined?*

The current coalmine exposure standard was determined after extensive research at a number of NSW coalmines in the early 1980's and these levels are constantly being reviewed in the light of new research. There has been a steady decrease in dust disease patterns in NSW coalmines over the last 30 years and consequently the Standing Dust Committee considers that compliance with current exposure standards will provide effective protection. The gravimetric measurement of respirable dust and quartz is the internationally recognised technique for monitoring the dust exposure of coal mineworkers.

*What is the inhalable dust exposure limit in NSW coal mines?*

Inhalable dust is the visible dust particles the 100 microns size. The limit under the *Coal Mine Health & Safety Act 2002* and *Regulation 2006 2* is based on the weight of inhalable dust in the air. It is the concentration in milligrams of inhalable dust per cubic metre (abbreviated to  $\text{mg}/\text{m}^3$ ) of air, collected from the breathing zone (not inside respirators or airstream helmets) of mine workers during their working shift

*The concentration of inhalable dust should not exceed 10  $\text{mg}/\text{m}^3$  in all coal mining operations.*

#### **5.2.2 Simtars QLD Statutory Dust Monitoring**

SIMTARS Background, Regulations and Testing Methodology for Queensland Respirable Dust Sampling (Extracted from actual testing report supplied by SIMTARS, file reference 50/010/0001/60/24, 2009)

#### Occupational Exposure to Dust

Most dusts contain particles of widely ranging sizes. The behaviour, deposition and fate of any individual particle after entry into the human respiratory system and the

## CHAPTER FIVE

### Current Australian and USA Dust Monitoring Practices

---

response that it elicits will depend on the nature and size of the particle. The respirable fraction of dust (aerodynamic diameter less 5 – 7 micrometres) is capable of reaching the lower bronchioles and alveolar regions of the lung. If the respirable fraction contains a proportion of a fibrogenic component such as quartz (crystalline silica - SiO<sub>2</sub>), a condition known as silicosis can result. Silicosis is an irreversible occupational lung disease, caused by the inhalation of silicon dioxide (silica) in crystalline forms, usually as quartz.

The key factor in assessing health implications of exposure to dust is the size of the air-borne dust cloud. Dust that falls predominantly into a larger size fraction (inhalable dust) can still have debilitating health consequences if in sufficient concentration but such dust, if inherently non-toxic or does not contain toxic impurities, is generally considered a nuisance dust. Therefore, highly visible dust clouds that are predominantly made up of nonrespirable particles and fall-out dust may not present a significant health risk. Conversely dust not visible to the naked eye made up of respirable particles could present a significant health risk especially if it contains a high percentage of crystalline silica.

According to the World Health Organisation International Agency for Research on Cancer, WHOIARC, (1997) Monographs on the Evaluation of Carcinogenic Risks to Humans, crystalline silica inhaled in the form of *quartz or cristobalite* from occupational sources is carcinogenic to humans. Continued exposure to fibrogenic dusts causes irreversible damage to the lung tissue and a consequent reduction in lung function that can lead to diseases of the cardiovascular system. Silica (silicon dioxide) is the main component of the earth's crust, which is why exposure to it cannot be eliminated, but needs to be controlled and reduced as far as possible. Respirable dust and quartz health risks are associated with mining, drilling, quarrying, tunnelling, sandblasting, foundries, refractory workers etc. Silicosis has a very long latency period, and some workers with current exposures may only become symptomatic in the next century, even after exposure has stopped.

## **CHAPTER FIVE**

### Current Australian and USA Dust Monitoring Practices

---

#### Sampling Strategy

Respirable dust samplers are distributed amongst a selection of personnel performing a range of activities. Respirable dust monitoring involves workers wearing a personal sampling device consisting of a constant flow sampling pump connected to a cyclone elutriator positioned within the breathing zone (300mm radius extending in front of the face and measured from the mid-point of a line joining the ears). Operators are requested to wear these devices for the entire shift, or a period representative of their normal duties.

#### Sampling Techniques

Results derived using these methods represent time weighted average concentrations of respirable dust encountered by operators during their normal working shift. With respect to respirable dust, a time-weighted average implies a mass of respirable dust collected over a known time period (preferably more than 4 hours) from which an average mass/volume concentration is calculated. It is from time weighted average concentrations that assessments are made with respect to acceptable health levels and compliance with regulatory requirements.

### **5.3 Discussion**

This chapter of the current dust mitigation controls used in Australian underground longwall mining indicates that while controls are in place for the mitigation of produced dust, these controls seem to be installed more in a hit and miss approach than implemented based on scientific foundations. This is evidenced by no clear approach to what sprays or control perform the best at specific locations, and no clear direction by suppliers of longwall equipment in relation to dust suppression or mitigation. Little or no thought is given to dust control at the time of scoping up supply of longwall equipment and only after a longwall commences operation, when problems arise relating to dust production, do thoughts turn to looking for solution to dust issues. At this time it is very difficult and in many instance expensive to measure control efficiencies, with many mines relying on subjective opinion as to the

## **CHAPTER FIVE**

### **Current Australian and USA Dust Monitoring Practices**

---

effectiveness of the installed controls. Little or no scientific research has been undertaken to quantify how effective installed controls are in relation to removing the produced dust on operating longwalls.

The evaluation of the current longwall controls for mitigating dust has highlighted a serious dichotomy in the results obtained during statutory testing for respirable and inhalable dust exposure levels.

Respirable dust exposure levels are well controlled, with less than 6.5% of all samples taken being the regulatory exposure limit, indicating that current installed dust mitigation controls are working.

In contrast to the success of longwall dust controls in mitigating respirable dust exposure levels, are the results of inhalable dust exposure levels testing, which shows that in excess of 30% of samples taken exceeded the statutory exposure levels.

This dichotomy of results indicates that a serious problem exists where the smaller respirable particles, usually less than 10 µm in size are removed from a contaminated airway, whereas the larger inhalable particles, usually greater than 10 µm, are not removed.

Further detailed analysis is required to determine why smaller particles are being removed from the contaminated atmosphere in Australian longwalls, whilst larger particles are remaining, with the current dust controls installed on these longwalls.

#### **5.4 Current USA Dust Monitoring Practices**

According to the Federal Register, October 19, 2010, Section 202(b)(2) of the Federal Mine Safety and Health Act of 1977 (Mine Act) requires each underground coal mine operator to continuously maintain the average concentration of respirable dust in the mine atmosphere during each shift to which each miner in the active workings is exposed at or  $2.0 \text{ mg/m}^3$ . Section 205 required that when coal mine dust contains

## **CHAPTER FIVE**

### **Current Australian and USA Dust Monitoring Practices**

---

more than five percent quartz, the respirable coal mine dust standard must be reduced according to a formula prescribed by NIOSH.

The Federal Register further states that under MSHA's existing standards, mine operators are required to collect bimonthly respirable dust samples and submit them to MSHA for analysis to determine compliance with applicable respirable dust standards (compliance samples). If compliance samples do not meet the requirements of the applicable dust standard, MSHA issues a citation for a violation of the standard and the operator is required to take corrective action to lower the respirable dust concentration to meet the standard.

Additionally, according to the Federal Register, the operator must collect additional respirable dust samples during the time established in the citation for abatement of the hazard or violation (abatement sampling). Underground coal mine operators must collect and submit two types of samples during bimonthly sampling periods: (1) "designated occupation" (DO) samples taken for the occupations exposed to the greatest concentrations of respirable dust in each mechanised mining unit (DOs are specified in s.70.207); and (2) "designated area" (DA) samples collected at locations appropriate to best measure concentrations of respirable dust associated with dust generation sources in the active working of the mine (s.70.208). The operator's approved ventilation system and methane and dust control plan, required in existing 30 CFR part 75, must show the specific locations in the mine designated for taking the DA samples. In addition, mine operators take respirable dust samples for part 90 miners (s.90.207 and s.90.208).

Current US compliance determinations are based on the average concentration of respirable dust measured by five valid respirable dust samples taken by the operator during five consecutive normal production shifts or five normal production shifts worked on consecutive days (multiple-shift samples). Compliance determinations are also based on the average of multiple measurements taken by the MSHA inspector over a single shift (multiple, single-shift samples) or on the average of multiple measurements obtained for the same occupation on successive days (multiple-shift

## **CHAPTER FIVE**

### **Current Australian and USA Dust Monitoring Practices**

---

samples) taken by the mine operators. The current Australian testing regime requires 5 workers on and about the face to be tested with gravimetric sampling for the entirety of the shift. These samplers are placed on the worker at the commencement of the shift and removed at the end of the shift. The samplers are placed by a qualified hygienist. These single samples either give a pass or fail for the worker.

Comparing the two methods, and subsequent cases of black lung, the Australian method would appear to be far more accurate than the US system.

## **5.5 Limitations of Current Statutory Testing Regimes**

### **5.5.1 Australian Limitations**

Calls from industry are pushing for a review of the current inhalable and respirable dust sampling methods used in Australia and to investigate alternative sampling methodologies applicable to major underground coal mining tasks, report on their validity within the codes, guidelines and standards and propose a new testing methodology that better identifies atmospheric contamination caused by dust produced during the cutting cycle in longwall mining.

It has been suggested that with changes in the work routines of many Australian miners, the traditional way of sampling is no longer adequate. Further, industry members believe that the current testing process is getting what are believed to be data errors arising from how sampling is being conducted not by over exposure to dust levels. Many samples are being contaminated leading to a failed result. The industry feels that rather than being recorded as a failure to the tested mines these should be deemed as invalid samples and quite rightly retested.

Mining industry members have been investigating alternative ways of placing dust sampling units to eliminate contamination whilst still meeting the strict codes, guidance and standards applied to this area. They also want to identify techniques that more accurately identify what specific work activities lead to specific results which will assist further in managing specific risks. Mining industry members would also

## **CHAPTER FIVE**

### **Current Australian and USA Dust Monitoring Practices**

---

like to look at instantaneous measuring devices that may also assist with identification and eventual mitigation of airborne contaminant risks.

It has further been suggested that there is a need to establish a database of Best Practice Dust suppression techniques used by longwalls for the industry to peruse and use along with the management of sampling data. Currently the industry invests a lot of money in the sampling conducted by the regulatory regime but receive very little useful information on how to mitigate airborne contaminants. With the volume of data collected the industry should have a fairly accurate picture and understanding of the underground longwall work environment to help refine installed controls and measure their dust knockdown efficiency, but currently only receive single sample information with details recorded for a 5 sample batch not individual samples. The industry feels it would be better to have information on individual pieces of plant & equipment, tasks & activities and on the practises of crews or individuals. The industry would also like to see a review which will document standards of approach in the areas of dust control efficiencies to capture a definitive benchmark which will allow for a more scientific approach to the management of airborne contaminants.

Finally, it has been suggested by the mining industry that a review of competency requirements for persons undertaking dust sampling be undertaken and that a review of the Occupational Exposure Limit is covered and suggested legislative Shift adjustment criteria is recommended specifically in the industry to better reflect the continual changes in the mining environment.

#### **5.5.2 US Limitations**

According to the Federal Register, October 19 2010, exposure to respirable coal mine dust can cause lung diseases including coal workers' pneumoconiosis (CWP), emphysema, silicosis, and chronic bronchitis, known collectively as "black lung." These diseases are debilitating, incurable, and can result in disability, and premature death. While considerable progress has been made in reducing the respirable coal mine dust levels, miners continue to develop black lung.



## CHAPTER FIVE

### Current Australian and USA Dust Monitoring Practices

---

Based on recent data from the NIOSH, the prevalence rate of black lung is increasing in the nation's coal miners; even younger miners are showing evidence of advanced and seriously debilitating lung disease (CDC, 2008).

The report continues further details that “in the last decade, death certificates list coal workers' pneumoconiosis, commonly called black lung disease, as a cause in more than 10,000 deaths. Black lung disease is caused by inhaling coal mine dust. It results in scarring of the lungs, emphysema and shortness of breath, disability, and premature death. The prevalence of black lung disease decreased by about 90% from 1969 to 1995 after the enactment of the Coal Mine Health and Safety Act. Unfortunately, since 1995, the prevalence of black lung among those who have participated in the Coal Workers' Health Surveillance Program and who have been coal miners for more than 20 years has more than doubled. We have seen severe and advanced cases in current underground miners as young as 39. Identification of advanced cases among miners under age 50 is of particular concern, as they were exposed to coal-mine dust in the years after the 1969 federal legislation had mandated disease-prevention measures. An increased risk of pneumoconiosis has been associated with work in certain mining jobs, in smaller mines, in several geographic areas, and among contract miners” (CDC, 2008).

The problem goes deeper for the testing regime in the USA as a direct result of a known increase in CWP identifying 1000 new cases per year since 1984 and the recent findings of the UBB disaster where autopsies revealed seventeen of the 24 victims' autopsies (or 71%) had CWP. This compares with the national prevalence rate for CWP among active underground miners in the USA which is 3.2%, and the rate in West Virginia which is 7.6%.

Further, of the 17 UBB victims with CWP, five of them had less than 10 years of experience as coal miners, while nine had more than 30 years of mining experience. At least four of the 17 worked almost exclusively at UBB. All but one of the 17 victims with CWP began working in the mines after the 2.0 milligram coal mine dust limit was put in affect in 1973. This was an exposure limit that was believed at the

## CHAPTER FIVE

### Current Australian and USA Dust Monitoring Practices

---

time sufficient to prevent black lung disease. This exposure limit has since been determined ineffective to protecting miners' health (McAteer 2010).

## 5.6 Summary

Both Australia and the USA have identified that the currently installed controls for the mitigation and removal of harmful coal dust from the underground mining environment have proven, in the first instance, to be hard to measure in terms of the success in mitigating airborne contaminants, and secondly, in the case of the USA, have failed to remove the risk of underground workers contracting CWP from their working environment.

In the case of the USA, The Federal Register, October 19, 2010 suggests that a reduction in the current exposure levels from  $2\text{mg}/\text{m}^3$  to  $1\text{mg}/\text{m}^3$  be implemented as the only practical solution to reducing the alarming increase in CWP amongst younger underground workers.

Along with the proposed reduction in exposure levels, several provisions in the proposed rule change, that is, basing noncompliance determinations on single shift sampling, sampling of extended work shifts to account for occupational exposures greater than 8 hours per shift, and changing the definition of normal production shift, would singularly lower coal miners' exposure to respirable dust. For example, MSHA's Quantitative Risk Assessment (QRA) estimates the reduction in health risks when two provisions of the proposed rule are implemented—the proposed respirable dust limit and single shift sampling. The QRA shows that these two proposed provisions would significantly reduce the risks of CWP, severe emphysema, and death from Non-Malignant Respiratory Disease (NMRD). The proposed rule change would potentially create 50 fewer cases of severe emphysema and 15 fewer deaths due to NMRD per thousand exposed cutting machine operators. The other provisions in the proposed rule would further reduce health risks to miners. Cumulatively, the proposed provisions would reduce the continued risks that coal miners face from

## **CHAPTER FIVE**

### **Current Australian and USA Dust Monitoring Practices**

---

exposure to respirable coal mine dust and would further protect them from the debilitating effects of occupational respiratory disease.

In Australia, it has been suggested that the traditional way of sampling is no longer adequate. Industry members believe that the current testing process is getting sample failures due to reasons other than high exposure levels, for example, uneven distribution of dust on the filter paper and pumps not running a full shift, and rather than being recorded as a failure to the tested mines these should be deemed as invalid samples and quite rightly retested.

Mining industry members also want to identify techniques that more accurately identify what specific work activities lead to specific results which will assist further in managing specific risks.

There also appears to be a need to establish a database of Best Practice Dust suppression techniques used by longwalls for the industry to peruse and use along with the management of sampling data. With the volume of data collected the industry should have a fairly accurate picture and understanding of the underground longwall work environment to help refine installed controls and measure their dust knockdown efficiency, but currently only receive single sample information with details recorded for a 5 sample batch not individual samples. The industry feels it would be better to have information on individual pieces of plant and equipment, tasks & activities and on the practises of crews or individuals. The industry would also like to see a review which will document standards of approach in the areas of dust control efficiencies to capture a definitive benchmark which will allow for a more scientific approach to the management of airborne contaminants.

Finally, it has been suggested that a review of competency requirements for persons undertaking dust sampling be undertaken and that a review of the Occupational Exposure Limit (OEL) is covered and suggested legislative Shift adjustment criteria is recommended specifically in the industry to better reflect the continual changes in the mining environment.

**CHAPTER SIX - DUST MITIGATION EFFICIENCY  
(DME) MODEL****6.1 Introduction**

As detailed in the summary in Chapter 5, the development of the Dust Mitigation Efficiency (DME) Model has been underpinned by an industry need that has determined that the current testing regime is no longer adequate to protect workers from harmful dust. Further, the industry has detailed the following issues underpinning the need for the DME Model;

- The current testing process is getting sample failures due to reasons other than high exposure levels and these are recorded as failures instead of retested;
- identify techniques that more accurately determine what specific work activities lead to specific results which will assist further in managing specific risks;
- a need to establish a database of Best Practice Dust suppression techniques used by longwalls for the industry to peruse and use along with the management of sampling data;
- the need to have information on individual pieces of plant and equipment, tasks and activities and on the practises of crews or individuals as opposed to simply exposure levels;
- the need for a review which will document standards of approach in the areas of dust control efficiencies to capture a definitive benchmark which will allow for a more scientific approach to the management of airborne contaminants; and
- the need for a review of competency requirements for persons undertaking dust sampling and that a review of the Occupational Exposure Limit is covered and suggested legislative Shift adjustment criteria is recommended specifically in the industry to better reflect the continual changes in the mining environment.

## **CHAPTER SIX**

### **Dust Mitigation Efficiency (DME) Model**

---

Evaluation of a workplace is primarily undertaken to establish if the workplace environment is safe for employees to perform their normal duties.

Occupational hygiene has been an integral part of the mining industry for centuries; however its importance has grown with mechanisation and rising community expectations of better occupational health. While the focus in the past has quite correctly been on improving the controls on dust exposure, the future lies in identifying the efficiency of installed controls on operating longwalls, evaluating them through robust and quantitative sampling methods to ensure the most effective controls are in place to prevent occupational disease from occurring in the mining industry.

According to AS2985 Workplace Atmospheres - Method for sampling and gravimetric determination of respirable dust occupational hygiene practice commonly differentiates between two size fractions of airborne dust, namely respirable and inhalable dust.

Respirable particles can be measured when the nature of these particles is such that they exhibit toxic effects primarily when deposited in the alveolar region (deepest reserve) of the lungs. This usually applies to toxic insoluble particles that accumulate in the lungs such as crystalline silica, coal dust and cadmium oxide fumes. This standard sets down the method for determining the mass concentration of these respirable sized particles in workplace atmospheres.

According to AS3640 where particles may have toxic effects if absorbed in the nasopharyngeal (nose and throat) region or may have toxic effects if ingested after deposition in this region, it is appropriate to measure the mass concentration of inhalable particles in the atmosphere. It may also be apt to measure this size fraction for particles that exhibit no specific toxic effects, namely, particulates/dust particles not otherwise classified.

## **CHAPTER SIX**

### Dust Mitigation Efficiency (DME) Model

---

Dust sampling in Australian coal mines is carried out with cyclone separation and collection of the sized particles for weighing, for at least a 5 hour period when possible to measure personal exposure levels to airborne contaminants of employees. This testing methodology is described in AS2985 Workplace Atmospheres - Method for sampling and gravimetric determination of respirable dust and AS3640 Workplace atmospheres - Method for sampling and gravimetric determination of inhalable dust.

These testing methodologies give an accurate Figure for the personal dust exposure levels of employees for the period sampled, but cannot be related to any actual longwall operational source of dust generation.

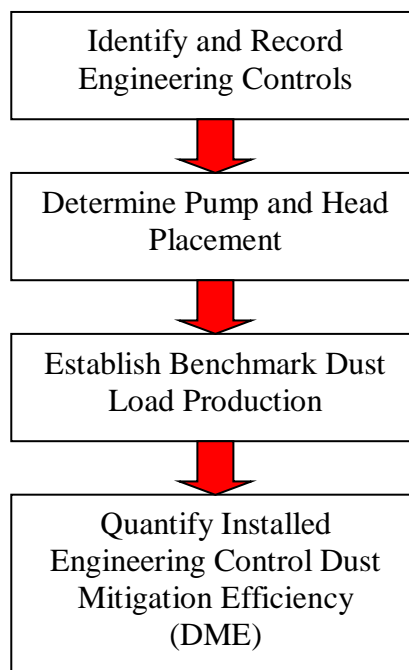
Statutory sampling methodologies do not accurately reflect the dust load entering the longwall from outbye sources and does not correlate in any way to the efficiency of dust mitigation control measures installed at those sources on Australian longwalls.

For the purpose of this research, gravimetric sampling will be used for dust load sampling to ensure uniformity of the collection process, validity of the collected data and quantification of the analysed results. Also, the sampling methodology has to be designed to ensure the collected data is deemed quantifiable and will stand the test of time to satisfy the requirements of a scientific research project and for reference in potential future projects.

The objective of this sampling methodology is to identify dust LOADS at independent sources of dust generation on longwall faces and quantify the efficiency of installed controls for the mitigation of produced dust. This data will then be used to create a benchmark or signature for each longwall mine in relation to dust loads from different sources of generation. Once this signature is established, quantifiable testing can be undertaken on new or improved controls to ensure maximum efficiency in removing respirable and inhalable dusts.

## 6.2 Testing Methodology

The testing methodology for the collection of respirable and inhalable dust loads at each independent source of dust generation on a longwall must be broken down into each individual task of the dust collection process. Figure 6.1 shows the tasks and steps in the DME model to be undertaken during the testing process.



**Figure 6.1 DME Model Flowchart**

### 6.2.1 Identify and Record Engineering Controls

Identify and record the installed engineering controls at each individual source of dust generation at each of the longwall mines to be tested, for example, spray type, amount, position, water pressure and flow. This can be performed at any time, prior to the commencement of sampling.

Appendix A shows an example of a questionnaire that was used to identify and record operating parameters and installed engineering controls used at each independent source of dust generation for each mine. In conjunction with this, an Order 40 form

## **CHAPTER SIX**

### **Dust Mitigation Efficiency (DME) Model**

---

from NSW Coal Services Pty Ltd issued to each mine will be examined and compared to actual installed engineering controls operating. Appendix B shows an example of the content of a Coal Services Order 40 application form.

This data will be recorded and later analysed in relation to dust load efficiency results to determine which mitigation set up is the most efficient at both inhalable and respirable dust knockdown based on dust monitoring tests at each source of dust generation.

This document will be completed at each longwall mine prior to the commencement of efficiency testing.

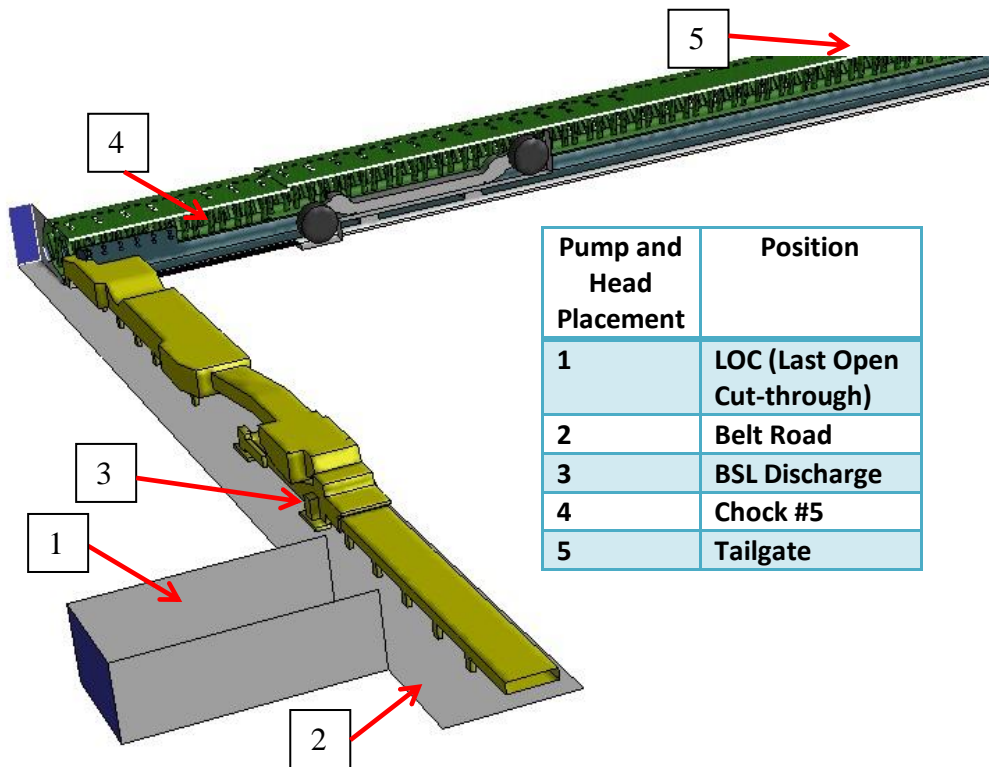
#### **6.2.2 Determine Pump and Head Placement**

The first stage in this methodology is to determine monitor placement on each of the independent sources of dust generation. In each location, two monitors and two heads will be used to sample both respirable and inhalable dust loads. Figure 6.2 details pump and head placement for data collection.



## CHAPTER SIX

### Dust Mitigation Efficiency (DME) Model



**Figure 6.2 Pump and Head Placement to Sample Longwall**

#### 6.2.2.1 Pump and Head Placement in LOC

Placement of the pumps and heads will be at the last open cut-through before the ventilation enters the longwall to measure the amount of respirable and inhalable dust brought into the longwall face from dust generated through vehicle movement and outbye activities. In most longwall mines the ventilation setup will have the main intake ventilation via the travel road and the belt road requiring monitors to be set up in each of these individually to identify dust loads from either source. Some mines may have intake ventilation via the travel road only with outbye belt air sealed to be in the return airway. This ventilation design will be identified for each mine during step 1 to ensure the correct amount of monitors and heads are available for the testing. Figure 6.3 denotes monitor and head positioning in the LOC.

## CHAPTER SIX

### Dust Mitigation Efficiency (DME) Model

---



**Figure 6.3 Pumps and Heads Positioned in LOC**

Both monitors will be positioned in the centre of the roadway hung from the roof so as to be in the middle of the intake air, but high enough so as not to be damaged or tampered with.

#### **6.2.2.2 Pump and Monitor Placement in Belt Road**

Pumps and heads will be placed in the belt road to measure the amount of respirable and inhalable dust brought into the longwall from dust generated from the coal being transported to the surface. Figure 6.4 shows location of pumps and heads in the belt road.

## CHAPTER SIX

### Dust Mitigation Efficiency (DME) Model

---



**Figure 6.4 Pump and Head Placement in Belt Road**

#### **6.2.2.3 Pump and Head Placement for BSL Discharge**

Sampling monitors and heads will be placed approximately 500mm inbye from the BSL discharge to the outbye belt and hung from the roof. They will be placed close to the walkway side of the discharge to allow for the heads to be changed without the need to walk on the top of the discharge.

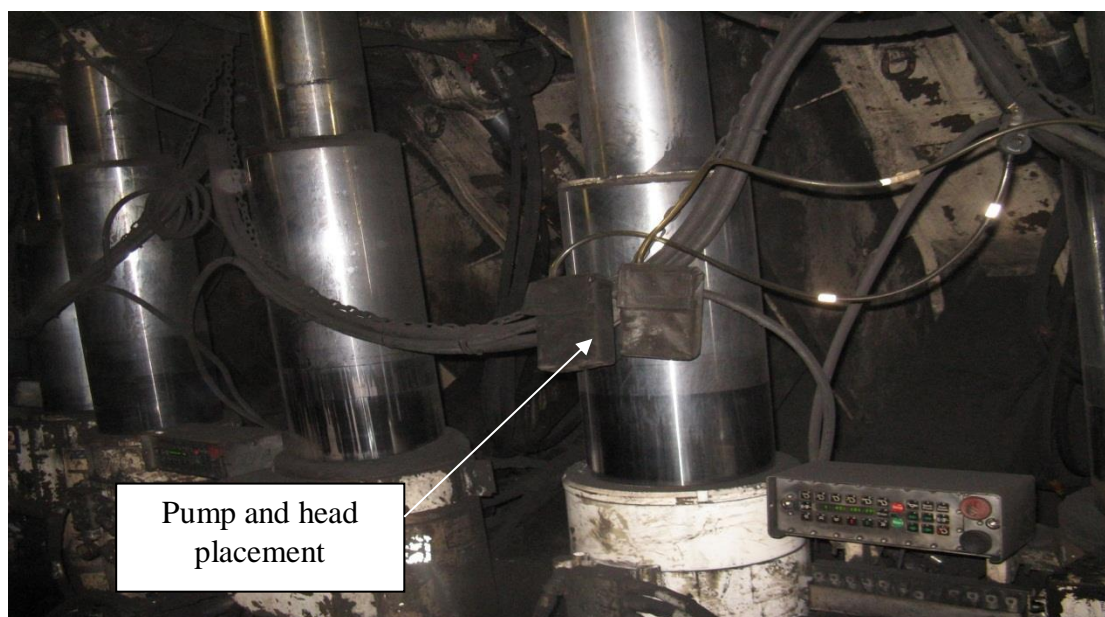
The heads will be changed and the monitors moved forward after the first sampling period of two shears has been completed. The replacement of the monitors will be necessary due to the pushing of the longwall at the completion of each shear. Figure 6.5 shows a BSL discharge onto the outbye conveyor with monitor and head placement for sampling.



**Figure 6.5 BSL Discharge**

#### **6.2.2.4 Pump and Head Placement for Crusher Intake**

Pumps and heads will be placed on or about chock #5 to collect dust coming into the longwall from outbye sources. The amount of dust generated by the crusher intake can be determined by taking away the LOC, Belt Road and BSL Discharge quantities. Figure 6.6 denotes placement of pumps and heads for dust collection on chock #5.



**Figure 6.6 Pump and Head Placement at Chock #5**

## **CHAPTER SIX**

### Dust Mitigation Efficiency (DME) Model

---

#### **6.2.2.5 Pump and Head Placement for Tailgate Chock**

Pumps and heads will be placed on the tailgate chock for the collection of the total amount of respirable and inhalable dust generated from all independent sources.

#### **6.2.3 Establish Benchmark Dust Load Production**

Determine the amount of dust produced with no operating controls at each individual source of dust generation. This will mean the mine has to turn off controls, i.e. sprays etc. to allow produced dust to be measured accurately at each of these sources.

This will not be an issue for the controls on outbye conveyors, travel roads, BSL discharge, crusher and chock sprays; however, turning off all controls on shearers will produce resistance. It will be necessary to leave the drum sprays on as in most applications these are used more for frictional ignition suppression than dust mitigation. Additional sprays such as crescent sprays and shearer clearers will be able to be turned off for the period of the testing; assuming gas levels are ignition points. A gas meter and suitably qualified person will be required at each of the sampling points when the controls are turned off. This will ensure that gas levels are monitored during the sampling period with sampling ceasing immediately should statutory levels of gas be exceeded.

#### **6.2.4 Quantify Control Dust Mitigation Efficiency**

Installed engineering controls will be turned back on and sampling heads changed to remeasure dust loads with controls operating. The difference between these two tests will determine the Dust Mitigation Efficiency (DME) of the installed controls.

### **6.3 Research Design**

#### **6.3.1 Applied Research for Data Collection**

Sampling data collected by Coal Services Pty Ltd (CSPL) as part of their Statutory sampling program for the underground coal mining industry requires them to collect these respirable and inhalable dust samples as per AS 2985 for respirable dust and AS

## CHAPTER SIX

### Dust Mitigation Efficiency (DME) Model

---

3640 for inhalable dust. The samples are collected using a 25mm filter that is weighed before the sample is taken (pre-weigh) and after the sample returns to the lab (post weigh). The difference between these two weights, in mg, is the raw data that is required for the DME model.

CSPL take this raw data and apply it to the calculations for Time Weighted Averages (TWA) called for in the Australian Standards. As a result of this calculation process, the raw data cannot be utilised for this thesis as the divisible variable, ie time taken for the sample, results in an exposure level for the worker and the tonnes cut during that time is recorded but not used for calculation purposes. The second reason that this data cannot be used, and the most important reason, is that the placement of the pumps and heads is on the workers in designated positions, which allows the determination of the exposure level for that worker. The new testing methodology requires placement of the pumps and heads as per 6.2.2 to collect raw data relevant to the identified source of respirable and inhalable dust generation.

Data required for this thesis is primary gathered data collected specifically for the project as no secondary data is available for analysis. The very nature of the primary gathered data dictates that this thesis is Applied Research. Applied Research is the original investigation undertaken in order to acquire new knowledge. It is directed primarily towards a specific practical aim or objective (Frascati, 2002), with the thesis objective being underpinned by the requirement of dust loads specifically collected at independent sources of dust generation with the controlling variable being the tonnes cut per sample period.

The necessity for primary gathered data has produced advantages and disadvantages that have had effects on the progress and obtained results of the thesis. The advantages have been:

- specific research issues have been addressed as the research has been controlled by the author and the research has been designed specifically for the thesis objectives; and

## CHAPTER SIX

### Dust Mitigation Efficiency (DME) Model

---

- greater control over how the data is collected, amount of samples to be collected, number of mines sampled and time frame to complete the sampling.

The disadvantages have been;

- the collection process has been very expensive. Costs have been incurred in collecting the data with an average set of 20 samples costing in the vicinity of \$2,000. This cost has been incurred in obtaining all the necessary inductions and qualifications for each mine sampled, as no two mines have the same induction process. This induction process includes the following requirements;
  - Coal mine medical from Coal Services in NSW and a registered practitioner in Qld. This medical includes a complete medical assessment, lung X-ray and functional fitness test. These medicals cost \$1500 in NSW and \$1,000 in Qld and both last for 2 years;
  - Generic coal mine inductions for NSW and Qld. Both generic inductions take approximately 1 week each and cost \$1200 in NSW and \$1200 in Qld;
  - Once the generic induction has been completed, each mine has a site specific induction over 3 days that includes an underground egress walk to allow the author to work accompanied underground;
  - Completion of up to 12 site competencies to be deemed as competent to collect data samples. Appendix C details competencies required for field trials;
- the data collection is reliant on the longwalls continued operation during the sampling period of controls off and on. Several tests have been undertaken where the longwall has broken down and the samples have been void as the testing was incomplete. This required retesting at a later date.

Applied Research is a systematic process involving the practical application of science. It accesses and uses parts of the other accumulated research, theories, knowledge, methods, and techniques, for the industry driven outcome of this thesis

## CHAPTER SIX

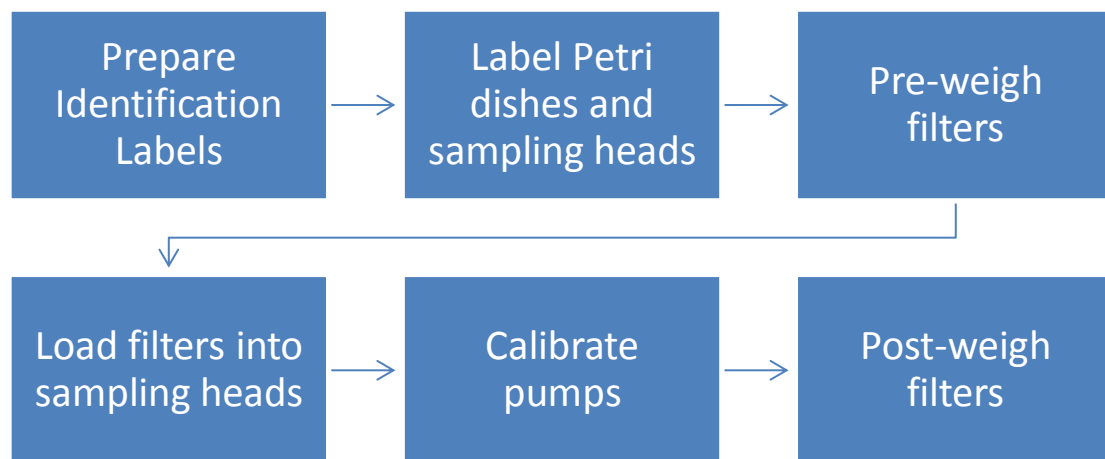
### Dust Mitigation Efficiency (DME) Model

---

and is detailed in the following sections, commencing with preparing the filters for dust sampling through to installing the pumps and heads on the longwall.

#### 6.4 Preparation Process for Data Collection

The preparation process for data collection requires the filters to be easily identified with the coal mine being sampled. This process is explained in the Figure 6.7.



**Figure 6.7 Data Collection Preparation Process Flowchart**



##### 6.4.1 Prepare Identification Labels

	<ul style="list-style-type: none"><li>Log onto the computer</li><li>Open Microsoft word</li><li>Click the mailing tab</li><li>Click on labels</li></ul>
--	---




## CHAPTER SIX

### Dust Mitigation Efficiency (DME) Model

	<p>A box will then come up saying envelopes or labels</p> <p>Click on the labels tab</p> <p>Make sure the labels are the right size J8651 Custom</p> <p>Click new document</p> <p>Edit the labels</p>
	<p>Press Print</p> <p>Rough Copy first with normal A4 paper</p> <p>Put labels into the printer and press print</p>




**Figure 6.8 Label Preparation Process**

#### 6.4.2 Preparing Petri Dishes for Filter Identification

	<p>Line up the heads (Respirable and Inhalable).</p> <p>Make sure all of the Respirable heads are together and all the Inhalable heads are together.</p>
---	--



## CHAPTER SIX

### Dust Mitigation Efficiency (DME) Model

	<p>Lay out the petri dishes (as many as you require)</p>
	<p>Apply the already made and printed labels to the head and petri dishes</p> <p>Apply the labels to the petri dishes</p>
	<p>Make sure your label match the right heads and Petri dishes</p>
	<p>Line the heads in order.</p> <p>Make sure the labels are all correct on the heads i.e. Benchmark,</p>

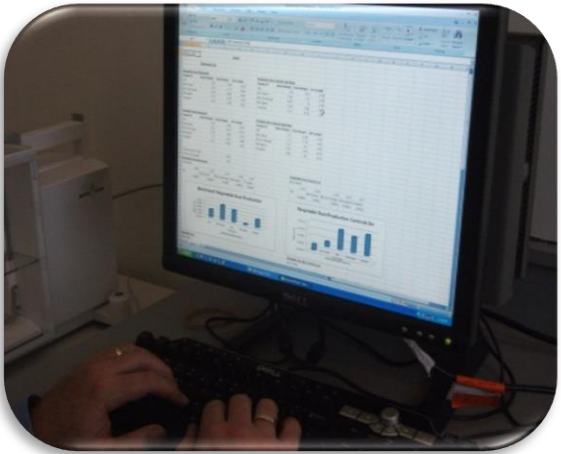
## CHAPTER SIX

### Dust Mitigation Efficiency (DME) Model

	<p>Controls test #2 with Respirable and Inhalable</p>
	<p>Line the petri dishes up to the correct heads</p>

**Figure 6.9 Filter Head Identification Process**

#### 6.4.3 Pre Weighing Filter Process

	<p>Log onto computer and log into program</p> <p>Open 'Dust Testing' file</p> <p>Locate customer in file (if none – Create new)</p> <p>Create new folder to match current test date on Petri dish</p> <p>Open dust testing template and complete template</p> <p>Date and save to file</p> <p>Save and close programme (set up file)</p>
---	--



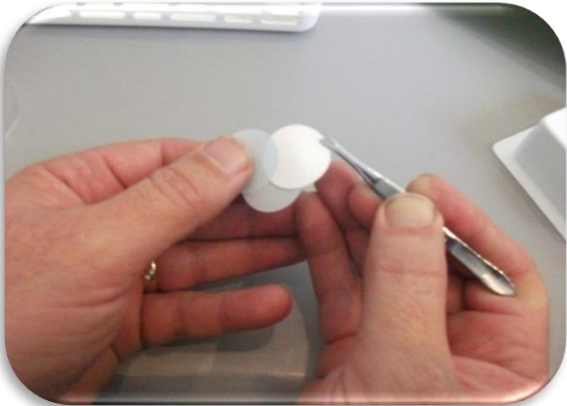

## CHAPTER SIX

### Dust Mitigation Efficiency (DME) Model

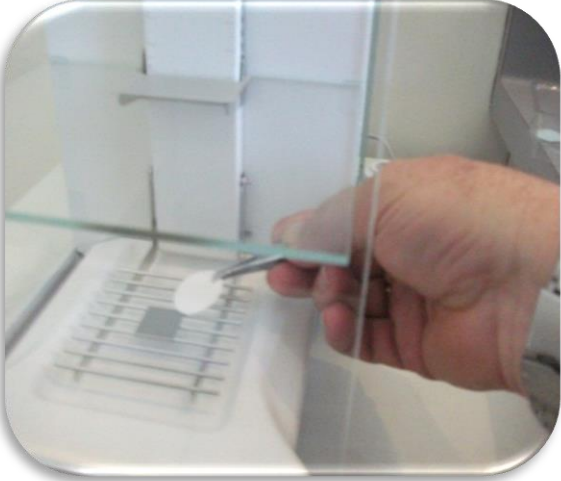
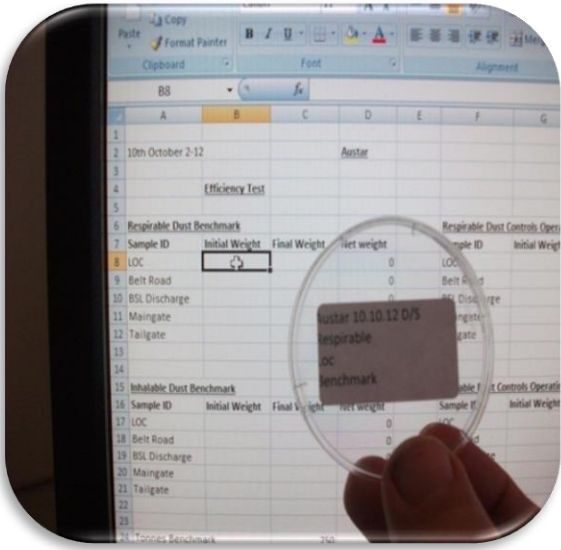

	<p>Open scale software (LABX DIRECT) on desktop</p> <p>Ensure language is English and click next</p> <p>Click next until you reach Task 4. Select target file. Open file &gt; dust &gt; testing file &gt; customer file &gt; date testing file &gt; open</p> <p>Click Apply</p>
	<p>Locate Filters</p> <p>Removing 5x Petri dishes from first set (Benchmark)</p>
	<p>Locate filter papers</p>
	<p>Remove from packet as per photo</p>

## CHAPTER SIX

### Dust Mitigation Efficiency (DME) Model

	<p>Locate and use tweezers to pick up individual filter paper</p>
	<p>Remove filter/protective cover</p>
	<p>Separate protective paper from filter gently</p> <p>Discard protective paper</p>
	<p>Turn on scales</p> <p>Ensure scales read 0.00</p>

**CHAPTER SIX**  
Dust Mitigation Efficiency (DME) Model

	<p>Open scale door Place filter on centre of scales close door Transfer weight to computer Open door remove filter</p>
	<p>Ensure active cell in spread sheet lines up with petri dish first line details  Ensure written scales confirmed weight record  Ensure weight recorded in active cell</p>
	<p>Place pre weighed filter in petri dish  Repeat procedure for all sample groups to be tested</p>

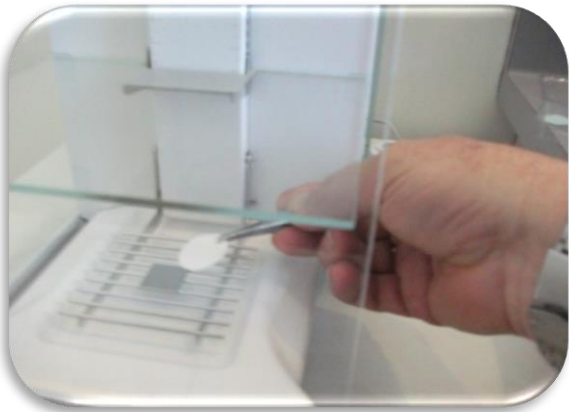
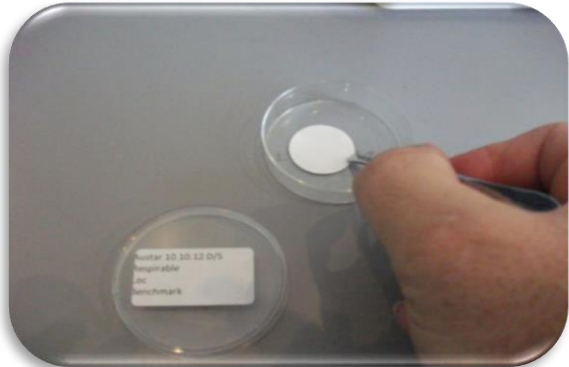

**Figure 6.10 Pre-Weighing Filter Process**

## CHAPTER SIX


### Dust Mitigation Efficiency (DME) Model

---

#### 6.4.4 Sampling Head Loading Process

	<p>Start with weighing the new filter</p>
	<p>Apply the new filter to the petri dishes (use tweezers at all time)</p>
	<p>Pull apart the head (As shown)</p> <p>Make sure petri dish with new filter lines up with the correct head</p>

**CHAPTER SIX**  
Dust Mitigation Efficiency (DME) Model

	<p>Gently remove the filter with the tweezers from the petri dish to the head.</p>
	<p>Put the Head back together</p>
	<p>Line the empty Petri dishes up with the loaded heads.  Ready to be collected by the Dust Sampler.</p>

**Figure 6.11 Head Loading Process**



## CHAPTER SIX

### Dust Mitigation Efficiency (DME) Model

---

## 6.5 Pump Calibration Process

### 6.5.1 Inhalable Pump Calibration Process

Pump calibration for inhalable dust sampling is required to ensure the correct flow of 2.0 lpm is going through the pump. The process for calibration is detailed in Appendix 6.

### 6.5.2 Respirable Dust Pump Calibration Process



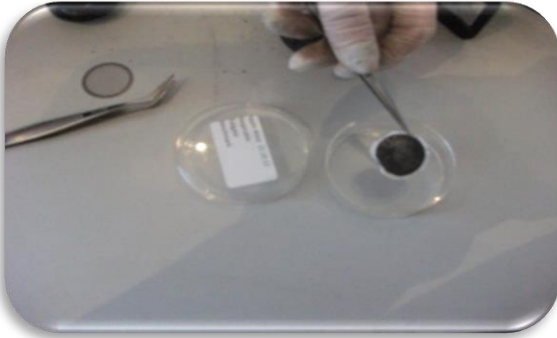
Pump calibration for respirable dust sampling is required to ensure the correct flow of 2.2 lpm is going through the pump. The process for calibration is detailed in Appendix 7.

## 6.6 Post-weigh Procedure




	<p>Receive petri dishes with dirty filters from the dust sampler</p> <p>Take heads out of the sandwich bags.</p> <p>Lay the heads on the bench</p> <p>Match the petri dishes to the heads</p> <p>Get someone to double check</p>
---	--

## CHAPTER SIX

### Dust Mitigation Efficiency (DME) Model

 A photograph showing the disassembled components of a dust mitigation head laid out on a white tray. From left to right, there is a black O-ring, a black circular head, a black circular filter, another black O-ring, and a black handle with a metal tip.	<p>Unscrew heads</p> <p>Make sure to have gloves on and some tweezers</p>
 Two photographs showing the process of lifting the filter. The top photo shows a pair of tweezers lifting a circular filter from a head. The bottom photo shows a pair of gloved hands holding the head and tweezers lifting the filter.	<p>Gently with the tweezers lift the filter off of the head.</p>
 A photograph showing a pair of gloved hands using tweezers to transfer a dark, dirty filter from a head into a petri dish. Another petri dish is visible in the background.	<p>Carefully locate the dirty filter from the head to petri dish.</p>

**CHAPTER SIX**  
Dust Mitigation Efficiency (DME) Model

	
	<p>Making sure the filter in the petri dish match up to the head.</p> <p>Get someone to double check when you are finished.</p>
	<p>When finished locating the filter from the head to the petri dishes.</p> <p>Put in the post weight basket.</p>

**Figure 6.12 Post-Weigh Process**

## **6.7 Calculating Dust Mitigation Efficiency**

### **6.7.1 Calculating Exposure Levels**

As discussed in Chapter 5, AS2985 and AS3640 utilise a time weighted average calculation for both respirable and inhalable dust to determine the exposure level of the person or place sampled. The key variable in this calculation is the time taken to

## CHAPTER SIX

### Dust Mitigation Efficiency (DME) Model

---

collect the sample. The time taken to collect the sample underpins the amount of respirable or inhalable dust that the person or place is exposed to over the period of the sample.

According to AS2985 and AS3640, the calculation process used to determine the exposure to both respirable and inhalable dust is as follows:

(a) Calculate the weight of dust collected, from the following equation:

$$w = (w2 - w1) - (b2 - b1)$$

#### Equation 6.1 Blank Corrected Filter Weight

where

$w$  = blank corrected weight of dust collected on the filter, in milligrams

$w1$  = weight of unladen filter, in milligrams

$w2$  = weight of used filter, in milligrams

$b1$  = weight of blank filter before sampling, in milligrams

$b2$  = weight of blank filter after sampling, in milligrams

(b) Calculate the average flow rate ( $Q$ ), and volume of air ( $V$ ) passed through each filter for the duration of sampling from the following equations:

$$Q = \frac{Q1 + Q2}{2}$$

#### Equation 6.2 Average Flow Rate

$$V = \frac{Q \times t}{1000}$$

#### Equation 6.3 Volume of Air

Where

$Q$  = average flow rate, in litres per minute

$Q1$  = initial flow rate, in litres per minute

$Q2$  = final flow rate, in litres per minute

$t$  = sampling duration, in minutes

$V$  = air volume, in cubic metres

## CHAPTER SIX

### Dust Mitigation Efficiency (DME) Model

---

(c) Calculate the average concentration ( $C$ ) of respirable dust from the following equation:

$$C = w/V$$

#### Equation 6.4 Average Concentration

Where

$C$  = dust concentration, in milligrams per cubic metre

$w$  = net weight of dust, blank corrected, in milligrams

$V$  = air volume, in cubic metres

The concentration in  $\text{mg}/\text{m}^3$  is the exposure level of the sample taken and this is then applied to the respirable or inhalable legislated exposure limit and either a pass or fail to this limit is determined.

#### 6.7.2 Calculating DME

Dust Mitigation Efficiency is calculated to determine the efficiency of installed controls as a percentage of a tested dust load benchmark. Two tests are undertaken, one as a benchmark with no engineering controls operating to mitigate the produced dust, and the second test performed with all engineering controls operating. The difference between controls off and controls on determines the DME which is a quantifiable number that shows the percentage decrease, or in some cases increase, of dust loads produced at independent sources of dust generation and how effective the installed controls are at mitigating this produced dust.

The calculation process to determine the respirable and inhalable DME is as follows:

$$\text{DME}_n = \left( \frac{\left( \frac{W_{ef} - W_{ei}}{T_e} \right) - \left( \frac{W_{bf} - W_{bi}}{T_b} \right)}{\left( \frac{W_{bf} - W_{bi}}{T_b} \right)} \right) \times 100$$

#### Equation 6.5 Dust Mitigation Efficiency

## CHAPTER SIX

### Dust Mitigation Efficiency (DME) Model

Where:

DME =	Dust Mitigation Efficiency
$n =$	Location of monitors and heads
$Wb_i =$	Weight of initial benchmark test filter unladen, in milligrams
$Wb_f =$	Weight of final benchmark test filter used, in milligrams
$T_b =$	Tonnes cut for benchmark testing
$We_i =$	Weight of initial efficiency test filter unladen, in milligrams
$We_f =$	Weight of final efficiency test filter used, in milligrams
$T_e =$	Tonnes cut for efficiency testing

The DME is presented as a percentage (%) change in the mg/tonne produced at each individual source of dust generation sampled. This can be either a positive or negative number, with the negative number representing a reduction in dust or a positive number an increase in dust when installed engineering controls are operating.

### 6.7.3 Example of DME Calculation

Following is an example of how a DME is calculated from collected samples at individual sources of dust generation.

**Table 6.1 Example Table of Results**

<b>Benchmark Test</b>							
<b>Respirable Dust Benchmark</b>				<b>Respirable Dust Controls Operating</b>			
Sample ID	Initial Weight	Final Weight	Net weight	Sample ID	Initial Weight	Final Weight	Net weight
LOC	7.08	7.69	0.61	LOC	7.34	7.97	0.63
Belt Road	7.02	7.77	0.75	Belt Road	7.13	7.3	0.17
BSL Discharge	6.97	8.08	1.11	BSL Discharge	7.54	8	0.46
Maingate	7.18	7.96	0.78	Maingate	7.71	7.99	0.28
Tailgate	7.11	7.89	0.78	Tailgate	7.54	8.18	0.64
<b>Inhalable Dust Benchmark</b>				<b>Inhalable Dust Controls Operating</b>			
Sample ID	Initial Weight	Final Weight	Net weight	Sample ID	Initial Weight	Final Weight	Net weight
LOC	7.3	7.89	0.59	LOC	7.54	8.06	0.52
Belt Road	7.2	7.73	0.53	Belt Road	7.45	7.62	0.17
BSL Discharge	7.51	7.66	0.15	BSL Discharge	7.44	8.1	0.66
Maingate	7.94	8.18	0.24	Maingate	7.3	8.16	0.86
Tailgate	7.48	8.14	0.66	Tailgate	7.21	8.2	0.99
Tonnes Benchmark		1184					
Tonnes Controls on		1117					

## CHAPTER SIX

### Dust Mitigation Efficiency (DME) Model

---

Table 6.1 shows a typical excel spread sheet of collected data from a longwall mine. The results are recorded in sample location, filter initial weight, filter final weight and the resulting net weight of the filter. The results are then separated into respirable benchmark testing, or samples taken with no controls operating, respirable efficiency testing, or samples taken with all controls operating, inhalable benchmark testing, or samples taken with no controls operating and inhalable efficiency testing, or samples taken with all controls operating. The tonnes cut for both tests were also recorded.

#### 6.7.4 Respirable DME at Last Open Cut-Through

$n$	$LOC$
$Wb_i$	7.08
$Wb_f$	7.69
$T_b$	1184
$We_i$	7.34
$We_f$	7.97
$T_e$	1117

$$\begin{aligned}\text{Respirable DME}_n &= \left( \frac{\left( \frac{W_{ef} - W_{ei}}{T_e} \right) - \left( \frac{W_{bf} - W_{bi}}{T_b} \right)}{\left( \frac{W_{bf} - W_{bi}}{T_b} \right)} \right) \times 100 \\ &= \frac{(7.97 - 7.34) - (7.69 - 7.08)}{\frac{(7.69 - 7.08)}{1184}} \times 100 \\ &= \frac{0.000564 - 0.000515}{0.000515} \times 100 \\ &= 9.51\%\end{aligned}$$

The DME at the LOC is 9.51% which represents a 9.51% increase in respirable dust produced with the installed engineering controls operating.

## CHAPTER SIX

### Dust Mitigation Efficiency (DME) Model

---

#### 6.7.5 Respirable DME at Belt Road

<i>n</i>	<i>Belt Road</i>
<i>Wb<sub>i</sub></i>	7.02
<i>Wb<sub>f</sub></i>	7.77
<i>T<sub>b</sub></i>	1184
<i>We<sub>i</sub></i>	7.13
<i>We<sub>f</sub></i>	7.30
<i>T<sub>e</sub></i>	1117

$$\begin{aligned}\text{Respirable DME}_n &= \left( \frac{\left( \frac{W_{ef} - W_{ei}}{T_e} \right) - \left( \frac{W_{bf} - W_{bi}}{T_b} \right)}{\left( \frac{W_{bf} - W_{bi}}{T_b} \right)} \right) \times 100 \\ &= \frac{(7.30 - 7.13) - (7.77 - 7.02)}{\frac{7.77 - 7.02}{1184}} \times 100 \\ &= \frac{0.000152 - 0.000633}{0.000633} \times 100 \\ &= -75.9\%\end{aligned}$$

The DME at the belt road is -75.9% which represents a 75.9% decrease in respirable dust produced with the installed engineering controls operating.



## CHAPTER SIX

### Dust Mitigation Efficiency (DME) Model

---

#### 6.7.6 Respirable DME at BSL Discharge

$n$	<i>BSL Discharge</i>
$Wb_i$	6.97
$Wb_f$	8.08
$T_b$	1184
$We_i$	7.54
$We_f$	8.00
$T_e$	1117

$$\begin{aligned}\text{Respirable DME}_n &= \left( \frac{\left( \frac{W_{ef} - W_{ei}}{T_e} \right) - \left( \frac{W_{bf} - W_{bi}}{T_b} \right)}{\left( \frac{W_{bf} - W_{bi}}{T_b} \right)} \right) \times 100 \\ &= \frac{(8.00 - 7.54) - (8.08 - 6.97)}{\frac{(8.08 - 6.97)}{1184}} \times 100 \\ &= \frac{0.000411 - 0.000937}{0.000937} \times 100 \\ &= -56.1\%\end{aligned}$$

The DME at the BSL discharge is -56.1% which represents a 56.1% decrease in respirable dust produced with the installed engineering controls operating.

## CHAPTER SIX

### Dust Mitigation Efficiency (DME) Model

---

#### 6.7.7 Respirable DME at the Maingate

<i>n</i>	<i>Maingate</i>
$Wb_i$	7.18
$Wb_f$	7.96
$T_b$	1184
$We_i$	7.71
$We_f$	7.99
$T_e$	1117

$$\begin{aligned}\text{Respirable DME}_n &= \left( \frac{\left( \frac{W_{ef} - W_{ei}}{T_e} \right) - \left( \frac{W_{bf} - W_{bi}}{T_b} \right)}{\left( \frac{W_{bf} - W_{bi}}{T_b} \right)} \right) \times 100 \\ &= \frac{(7.99 - 7.71) - (7.96 - 7.18)}{\frac{1117}{(7.96 - 7.18)} \cdot \frac{1184}{1184}} \times 100 \\ &= \frac{0.000250 - 0.000658}{0.000658} \times 100 \\ &= -62\%\end{aligned}$$

The DME at the maingate is -62% which represents a 62% decrease in respirable dust produced with the installed engineering controls operating.

## CHAPTER SIX

### Dust Mitigation Efficiency (DME) Model

---

#### 6.7.8 Respirable DME at the Tailgate

<i>n</i>	<i>Tailgate</i>
$Wb_i$	7.11
$Wb_f$	7.89
$T_b$	1184
$We_i$	7.54
$We_f$	8.18
$T_e$	1117

$$\begin{aligned}\text{Respirable DME}_n &= \left( \frac{\left( \frac{W_{ef} - W_{ei}}{T_e} \right) - \left( \frac{W_{bf} - W_{bi}}{T_b} \right)}{\left( \frac{W_{bf} - W_{bi}}{T_b} \right)} \right) \times 100 \\ &= \frac{(8.18 - 7.54) - (7.89 - 7.11)}{\frac{(7.89 - 7.11)}{1184}} \times 100 \\ &= \frac{0.000573 - 0.000659}{0.000659} \times 100 \\ &= -13\%\end{aligned}$$

The DME at the tailgate is -13% which represents a 13% decrease in respirable dust produced with the installed engineering controls operating.

## CHAPTER SIX

### Dust Mitigation Efficiency (DME) Model

---

#### 6.7.9 Inhalable DME at Last Open Cut-through (LOC)

<i>n</i>	<i>LOC</i>
<i>Wb<sub>i</sub></i>	7.30
<i>Wb<sub>f</sub></i>	7.89
<i>T<sub>b</sub></i>	1184
<i>We<sub>i</sub></i>	7.54
<i>We<sub>f</sub></i>	8.06
<i>T<sub>e</sub></i>	1117

$$\begin{aligned}\text{Inhalable DME}_n &= \left( \frac{\left( \frac{We_f - Wei}{Te} \right) - \left( \frac{Wbf - Wbi}{Tb} \right)}{\left( \frac{Wbf - Wbi}{Tb} \right)} \right) \times 100 \\ &= \frac{(8.06 - 7.54) - (7.89 - 7.30)}{\frac{1117}{(7.89 - 7.30)} \cdot \frac{1184}{1184}} \times 100 \\ &= \frac{0.000466 - 0.000498}{0.000498} \times 100 \\ &= -6.4\%\end{aligned}$$

The DME at the LOC is -6.4% which represents a 6.4% decrease in inhalable dust produced with the installed engineering controls operating.

## CHAPTER SIX

### Dust Mitigation Efficiency (DME) Model

---

#### 6.7.10 Inhalable DME at Belt Road

<i>n</i>	<i>Belt Road</i>
$Wb_i$	7.20
$Wb_f$	7.73
$T_b$	1184
$We_i$	7.45
$We_f$	7.62
$T_e$	1117

$$\begin{aligned}\text{Inhalable DME}_n &= \left( \frac{\left( \frac{We_f - We_i}{T_e} \right) - \left( \frac{Wb_f - Wb_i}{T_b} \right)}{\left( \frac{Wb_f - Wb_i}{T_b} \right)} \right) \times 100 \\ &= \frac{(7.62 - 7.45) - (7.73 - 7.20)}{\frac{(7.73 - 7.20)}{1184}} \times 100 \\ &= \frac{0.000152 - 0.000448}{0.000448} \times 100 \\ &= -66\%\end{aligned}$$

The DME at the belt road is -66% which represents a 66% decrease in inhalable dust produced with the installed engineering controls operating.

## CHAPTER SIX

### Dust Mitigation Efficiency (DME) Model

---

#### 6.7.11 Inhalable DME at BSL Discharge

<i>n</i>	<i>BSL Discharge</i>
$Wb_i$	7.51
$Wb_f$	7.66
$T_b$	1184
$We_i$	7.44
$We_f$	8.10
$T_e$	1117

$$\begin{aligned}\text{Inhalable DME}_n &= \left( \frac{\left( \frac{We_f - We_i}{T_e} \right) - \left( \frac{Wb_f - Wb_i}{T_b} \right)}{\left( \frac{Wb_f - Wb_i}{T_b} \right)} \right) \times 100 \\ &= \frac{(8.10 - 7.44) - (7.66 - 7.51)}{\frac{(7.66 - 7.51)}{1184}} \times 100 \\ &= \frac{0.000590 - 0.000127}{0.000127} \times 100 \\ &= 365\%\end{aligned}$$

The DME at the BSL discharge is 365% which represents a 365% increase in inhalable dust produced with the installed engineering controls operating.

## CHAPTER SIX

### Dust Mitigation Efficiency (DME) Model

---

#### 6.7.12 Inhalable DME at the Maingate

<i>n</i>	<i>Maingate</i>
$Wb_i$	7.94
$Wb_f$	8.18
$T_b$	1184
$We_i$	7.30
$We_f$	8.16
$T_e$	1117

$$\begin{aligned}\text{Inhalable DME}_n &= \left( \frac{\left( \frac{We_f - We_i}{T_e} \right) - \left( \frac{Wb_f - Wb_i}{T_b} \right)}{\left( \frac{Wb_f - Wb_i}{T_b} \right)} \right) \times 100 \\ &= \frac{(8.16 - 7.30) - (8.18 - 7.94)}{\frac{(8.18 - 7.94)}{1184}} \times 100 \\ &= \frac{0.000770 - 0.000203}{0.000203} \times 100 \\ &= 279\%\end{aligned}$$

The DME at the maingate is 279% which represents a 279% increase in inhalable dust produced with the installed engineering controls operating.

## CHAPTER SIX

### Dust Mitigation Efficiency (DME) Model

---

#### 6.7.13 Inhalable DME at the Tailgate

<i>n</i>	<i>Tailgate</i>
$Wb_i$	7.48
$Wb_f$	8.14
$T_b$	1184
$We_i$	7.21
$We_f$	8.20
$T_e$	1117

$$\begin{aligned}\text{Inhalable DME}_n &= \left( \frac{\left( \frac{Wef - Wei}{Te} \right) - \left( \frac{Wbf - Wbi}{Tb} \right)}{\left( \frac{Wbf - Wbi}{Tb} \right)} \right) \times 100 \\ &= \frac{(8.20 - 7.21) - (8.14 - 7.48)}{\frac{(8.14 - 7.48)}{1184}} \times 100 \\ &= \frac{0.000886 - 0.000557}{0.000557} \times 100 \\ &= 59\%\end{aligned}$$

The DME at the tailgate is 59% which represents a 59% increase in inhalable dust produced with the installed engineering controls operating.



## **6.8 Instrumentation for Data Collection**

AS2985 and AS3640 clearly define the process to be used to determine personal exposure levels in coal mines. For the purpose of this efficiency sampling, the same equipment will be used to collect dust load at each individual source of dust generation on a longwall to ensure uniformity of collected data, reliability of data analysis and approval for use in underground coal mines.

### **6.8.1 AS2985 Respirable Dust Sampling**

Section 6.1 of AS2985 - Workplace atmospheres - method for sampling and gravimetric determination of respirable dust states the essential features of a sampling system are a filter (on which the sample is collected) and a pump for drawing the air through the filter. The filter shall be secured in a holder that prevents air from leaking around the edge of the filter. The filter shall be preceded by a size-selective sampler.

Section 6.4 of AS2985 states that sampling pumps shall be capable of operation at the designated flow rate  $\pm 0.1$  L/min for the duration of the sample period. The pulsation ratio shall not exceed 0.2 and preferably be less than 0.1. Some pumps may require pulsation dampers to achieve this performance. Figure 6.13 shows the approved SKC pump for use in respirable and inhalable dust sampling.

## CHAPTER SIX

### Dust Mitigation Efficiency (DME) Model

#### A. THE UNIVERSAL PUMP

- |                                  |                                   |                                    |
|----------------------------------|-----------------------------------|------------------------------------|
| 1. LCD Display                   | 10. ON/OFF Switch                 | 19. Low Flow Mode Screw Cover      |
| 2. Flow and Battery Check Button | 11. Accessory Mounting Screws     | 20. Battery Pack                   |
| 3. Start/Hold Button             | 12. Built in Flow Indicator       | 21. Cover over Regulator           |
| 4. Set-Up Button                 | 13. Filter Housing Screws (4 off) | 22. Belt Clip                      |
| 5. Mode Button                   | 14. Filter O Ring Seal            | 23. Main Case Screws (4 off)       |
| 6. Select Button                 | 15. Protection Filter             | 24. Charging Jack                  |
| 7. Set Button                    | 16. Protection Filter Housing     | 25. Battery Pack Screws (2 off)    |
| 8. Flow Adjust Control Screw     | 17. Air Inlet                     | 26. Compensation Adjustment Covers |
| 9. Cover Retaining Screw         | 18. Exhaust Port Cover            |                                    |

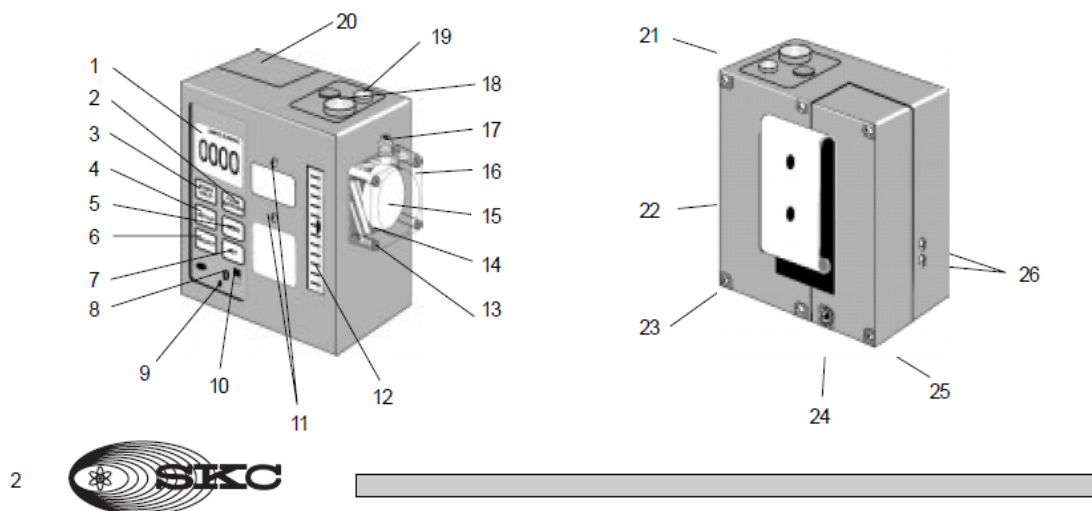


Figure 6.13 The Universal Pump by SKC

Section 6.2 of AS2985 further states that the respirable fraction shall be collected by using a size-selective sampler. Such devices include miniature cyclones such as the British Cast Iron Research Association (BCIRA) Higgins and Dewell and Safety in Mines Research Establishment Personal Dust Sampler (SIMPEDS)

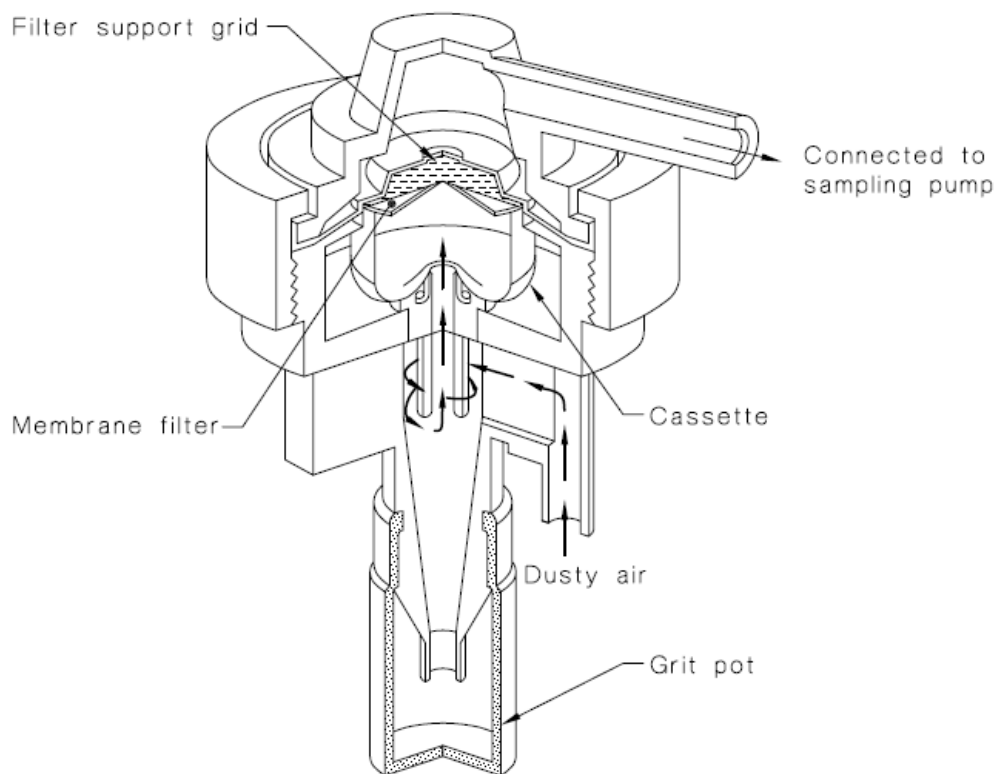
Section 6.3 of AS2985 details that the filter size shall be chosen to suit the sampling head. Filters of 25 mm diameter are preferred, but a 37 mm diameter filter may be used. Filters of nominal pore size of  $5\mu\text{m}$  or less shall be used. The type of filter material shall be chosen so that electrostatic charge, moisture variations, and loss of filter or sample do not significantly affect the analysis. In general, electrostatic charge problems have to be overcome with PVC and polycarbonate filters; significant moisture variations affect cellulose filters; loss of filter can occur with silver

## CHAPTER SIX

### Dust Mitigation Efficiency (DME) Model

---

membrane and glass fibre filters. If polycarbonate filters are used, the nominal bore size shall be  $0.8\mu\text{m}$  or less. Care should be taken to ensure that there is no sample loss during use or transportation. Figure 6.14 shows the respirable sampling head used for data collection.



**Figure 6.14 Respirable Cyclone Head**

### 6.8.2 AS3640 Inhalable Dust Sampler

According to section 6.1 of AS3640 - Workplace atmospheres - method for sampling and gravimetric determination of inhalable dust the essential features of a sampling system are an inhalable dust sampling device (containing a filter on which the sample is collected) and a pump for drawing the air through the device. The filter shall be

## CHAPTER SIX

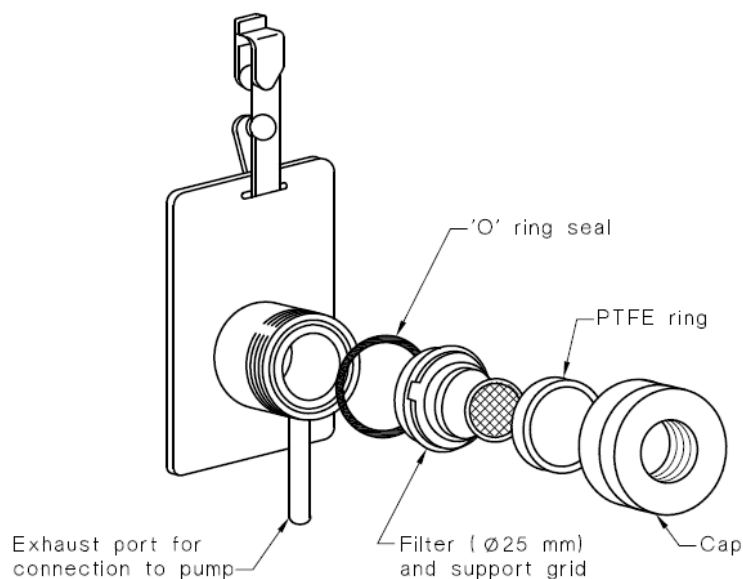
### Dust Mitigation Efficiency (DME) Model

---

secured in the device in such a manner that it prevents air from leaking around the edge of the filter.

Section 6.2 details that the inhalable fraction shall be collected by using a sampling device that satisfy the ISO 7708 criteria. For example:

IOM inhalable dust sampling head. The UK Institute of Occupational Medicine, Edinburgh has developed a personal sampler for inhalable dust (Figure 6.15), which embodies a single orifice entry and a filter contained within a special cassette. The cassette and the enclosed filter may be weighed either separately or together. The sampler requires a pump unit capable of maintaining a smooth flow rate of  $2.0 \pm 0.2$  L/min throughout the sampling period.



**Figure 6.15 IOM Inhalable Fraction Head**

The sampling head is suitable for sampling particles smaller than approximately  $30\mu\text{m}$  to  $50\mu\text{m}$  EAD, which is the most common requirement.

## 6.9 Risk Assessments

All mines tested required a risk assessment to be carried out to identify the risks and hazards involved in turning the installed engineering controls off. From these risk assessments, it was determined that the shearer drum sprays had to remain on as they were essential to minimize the risk of frictional ignition during the cutting cycle.

The structured approach to the process of occupational hygiene issue management revolves around the process of risk assessment. Specific details on the risk assessment process can be obtained by reading AS/NZS 3931:19981 and AS/NZS 4360:20042. A matrix used by a number of coal mining operators in NSW for the evaluation of occupational health and safety issues has been used to highlight how the process works and this process should be recognized and included in this methodology.

### Step 1

The fundamental basis for any risk management approach is a belief that all workplaces should be free, as is reasonably practicable, of potential hazards that could give rise to adverse health effects. To ensure this, in respect to occupational hygiene, there is a need for total team commitment for this project that should include:

- all equipment and processes on-site that may give rise to potential adverse health effects be identified and evaluated;
- any situations that are identified as problems or issues be assigned a relative risk ranking; and
- where appropriate, risk assessments are applied and interpreted by professionally qualified personnel.

Control strategies are initiated to:

- Reduce exposures where possible;
- Eliminate hazards where possible; and
- Maintain control over workplace hazards

## **CHAPTER SIX**

### Dust Mitigation Efficiency (DME) Model

---

Effective personal protective equipment is to be provided to the workforce in the area of sampling, where necessary, to ensure that those atmospheric contaminants do not give rise to adverse health effects for the period of the sampling with the controls off.

#### **Step 2**

A Risk Assessment Team should be formed to evaluate the issue or process for possible adverse health effects. This may be incorporated as part of the responsibility of the site dust committee if one exists. Each Risk Assessment Team would normally include the following:

- Supervisor familiar with the process or procedure (Team Leader).
- Workforce representative(s) from area involving the process or procedure.
- Safety coordinator for area under review.

The Risk Assessment Team has responsibility for:

- Obtaining all information and advice necessary to plan an accurate assessment for the sampling period.
- The assessment of any equipment, process or procedure in terms of adverse health effects attributable to this project.
- The assignment of a category rating for all potential problems and issues.
- The indication of new or changed safe work practices or control strategies that must be developed for the project.
- Notifying the Manager, the Safety Advisor and the Occupational Health and Safety Committee of any significant or moderate risk attributable to the project.

#### **Step 3**

Once the Risk Assessment Team has been formed the team leader should arrange a short planning meeting where the following topics are addressed:

- All team members are familiarised with the specific issue, process or procedure to be evaluated.

## CHAPTER SIX

### Dust Mitigation Efficiency (DME) Model

---

- All available information should be tabled to enable a comprehensive risk assessment. If it is judged that more information is required then it is the team leader's responsibility to obtain that material before the process proceeds.

#### Step 4

The Risk Assessment then assigns a risk rank level to the situation under review. This is done by the use of a Risk Rank Model, where;

RISK = PROBABILITY X CONSEQUENCE and;

RISK RANK 1-3 (SIGNIFICANT) = RED

RISK RANK 4-13 (MODERATE) = YELLOW

RISK RANK 14-20 (LOW) = GREEN

The risk model used is very simplistic and some mines may have more complex models which suit the needs of their individual operation. Irrespective of the model used the process remains the same and will be updated to the matrix as deemed operable by the mine site.

## CHAPTER SIX

### Dust Mitigation Efficiency (DME) Model

**Table 6.2 Risk Ranking Model**

#### RISK RANKING MODEL

		PROBABILITY				
		A	B	C	D	E
C O N S E Q U E N C E	1	1	2	4	7	11
	2	3	5	8	12	15
	3	6	9	13	16	18
	4	10	14	17	19	20

PROBABILITY CATEGORY	DEFINITION
A	possibility of repeated incidents
B	isolated incidents known to have occurred
C	possibility of occurring some time
D	unlikely to occur
E	practically impossible

CONSEQUENCE CATEGORY	DEFINITION
1	serious long or short term health effects that may be fatal
2	serious adverse health effects that would require off-site medical treatment
3	non life threatening health effects that may require on-site first aid treatment
4	little if any adverse health effects



## **CHAPTER SIX**

### Dust Mitigation Efficiency (DME) Model

---

#### **Step 5**

Clear, concise records of the risk assessment process must be maintained in the Mine files, indicating who conducted the review, on the basis of the assessment, the result of the assessment and any recommendations for control strategies, (and whether adopted, with date of implementation).

Appendix 4 shows a detailed risk assessment for Mine A and Appendix 5 shows a detailed risk assessment to attach pumps and heads to the shearer at Mine C.

#### **6.10 Summary**

Following on from the identified need in Chapter 5 for the development of an alternative testing method for determining respirable and inhalable dust levels, Chapter 6 has discussed in detail the development of the Dust Mitigation Efficiency Model and detailed how the calculation process for DME determination is carried out. The DME model has been successful in quantifying the mitigation efficiency of installed engineering controls for respirable and inhalable dust produced at each known source of dust generation.

By determining benchmark respirable and inhalable dust loads where installed engineering controls are turned off and re-measuring these dust loads with installed controls operating, a quantifiable percentage reduction, or in some cases an increase, in respirable and inhalable dust loads at identified sources of dust generation is produced. This DME can then be continually monitored as part of a Dust Management Plan that may include alternative mitigation controls installed or trialled to increase mitigation of the produced dust.

Chapter 6 has also detailed the comprehensive process required that underpins final data collection, from filter preparation and data recording to head and monitor placement on the longwall for data collecting.

Chapter 6 further discusses the compliance requirements from tested longwalls to enable the DME model to be used.

## CHAPTER SEVEN

### Field Trials In Australian Longwalls

---

## CHAPTER SEVEN - FIELD TRIALS IN AUSTRALIAN LONGWALLS

In this thesis, with the development of the DME model completed, field trials were undertaken to ascertain any measurable benefits the new testing methodology can provide to mine operators to better understand the production of dust loads on Australian longwalls as both a benchmark dust production and how effectively installed controls mitigate that produced dust.

Field trials were undertaken at 5 Australian longwalls incorporating 190 respirable dust samples and 170 inhalable dust samples. Table 7.1 shows details of mines where field trials were undertaken.

**Table 7.1 Mines where field trials were undertaken, seams and seam thicknesses**

Mine A	Mine B	Mine C	Mine D	Mine E
NSW/Hunter	NSW/Southern	NSW/Southern	Qld/Northern	NSW/Newcastle Newcastle
Middle Liddell/ 2.3-2.8m	Bulli/ 2.8-3.2m	Bulli, 2.8-3.4m	Goonyella Middle/ 3.8-4.5m	Greta

### 7.1 Field Study Mine A

Mine A was the first mine to undertake the field study with the data being collected by Coal Services. Instructions relating to pump and head placement were recorded and data was collected as per the collection process detailed in Chapter 6. Raw data results, ie the measured difference between the pre weighed filter and the post weighed filter, were received by the author after completion of the field trial by Coal Services. This raw data was analysed utilising the Dust Mitigation Efficiency formula detailed in section 6.3.7.

## CHAPTER SEVEN

### Field Trials In Australian Longwalls

---

#### 7.1.1 Operational Parameters of Mine A

Table 7.2 details the operating parameters of Mine A.

**Table 7.2 Mine A Operational Parameters**

	<b>Mine A</b>
<b>State/Coalfield</b>	New South Wales/Hunter
<b>Seam/Working thickness, metres (m)</b>	Middle Liddell/ 2.3-2.8m
<b>Coal Type</b>	Thermal
<b>Depth of cover, metres (m)</b>	300-500m
<b>Marketable reserves, proved and probable, million tonnes (Mt)</b>	34Mt
<b>Longwall operations (weekly)</b>	5 x 8.5hr shifts, 8 x 10hr shifts and 6 x 12hr shifts, weekly; 19 unit shifts
<b>Other operations (weekly)</b>	5 x 8.5hr shifts, 8 x 10hr shifts and 6 x 12hr shifts, weekly; 38 unit shifts
<b>Raw coal output 2011, tonnes</b>	
Longwall face, tonnes	1,417,900
Other, tonnes	8,700
Total, tonnes	1,426,600
Forecast total raw coal output 2012, tonnes	not available
Longwall face raw coal output 2010-11, tonnes	1,248,000
Total mine raw coal output 2010-11, tonnes	1,438,000
<b>Commenced longwall mining</b>	Aug-02
<b>Longwall block dimensions 2011</b>	
Width, metres (m)	246m, 246m
Length, metres (m)	2388m, 2555m
<b>Shearer manufacturer</b>	Eickhoff
Type	SL750 DERDS
Drum diameter, metres (m)	M/G 2m, T/G 2m
<b>Cutting height, metres (m)/ Method/ Web depth, millimetres (mm)</b>	2.3-2.8m, Bi-di, 1000mm
<b>Install power, kilowatts (kW)</b>	1474kW
<b>Roof support manufacturer</b>	Bucyrus
Type/Number of supports	2-leg chock, 143
Yield load, tonnes (t) Working range, metres (m) Control	1050t, 1.4-3.1m, PM4
<b>Face conveyor manufacturer</b>	Bucyrus
Width, millimetres (mm) Chain size, millimetres (mm)	1000mm PF4, 42mm twin-in-board

## CHAPTER SEVEN

### Field Trials In Australian Longwalls

Chain speed metres per second (m/s) Manufacturer	1.49m/s, THIELE
Motors, kilowatts (kW)	2 x 855kW
Beam stage loader manufacturer kilowatts (kW)	Bucyrus, 1532mm/PF4, 400kW
Coal crusher manufacturer, kilowatts (kW)	Bucyrus, SK11/18, 400kW
Coal clearance (to surface) type, Capacity, tonnes per hour (tph)	Conveyor, 3200tph
Shearer drum speed	42rpm
Shearer Speed	5-8m/min
Av. Shears per Shift	4
Av. Tonnes per Shear	2000
Ventilation on Longwall	45m <sup>3</sup> /sec

### 7.1.2 Pump and Head Location Mine A

Placement of the pumps and gravimetric heads will be at the last open cut-through before the ventilation enters the longwall, the belt road, BSL discharge, chocks 1 through 105, the tailgate and the maingate and tailgate shearer operator. Figure 7.1 denotes pump and head positioning for this field trial.

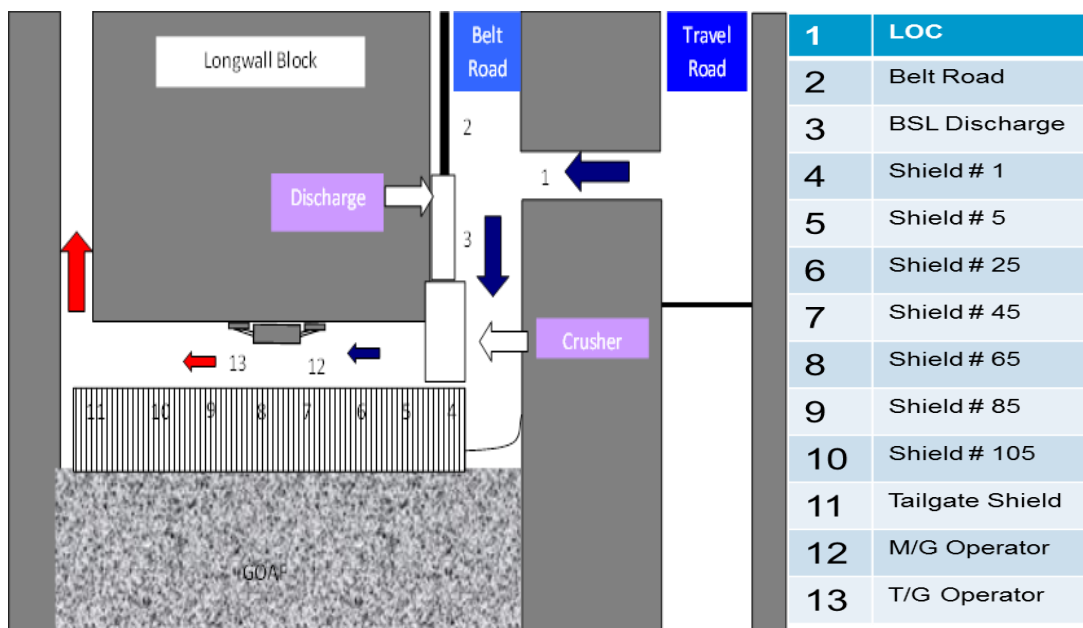


Figure 7.1 Mine A pump and head location

#### 7.1.2.1 Pump and Head Location in Last Open Cut-through

The monitors and gravimetric heads were placed in the last open cut-through before the ventilation enters the longwall to measure dust entering the longwall from outbye

travel roads. Figure 7.2 denotes the positioning of pumps and heads in the last open cut-through.



**Figure 7.2 Mine A Pump and Head Location in LOC**

### **7.1.2.2 Pump and Head Location in Belt Road**

The monitors and gravimetric heads were placed in the belt road to measure fugitive dust entering the longwall from the conveyor belt. Figure 7.3 denotes the positioning of pumps and heads in the belt road.

## CHAPTER SEVEN

### Field Trials In Australian Longwalls

---



**Figure 7.3 Mine A Pump and Head Location in the Belt Road**

#### **7.1.2.3 Pump and Head Location at BSL Discharge**

Sampling monitors and heads were placed inbye from the BSL discharge to the outbye belt and hung from the roof. They were placed close to the walkway side to allow for the heads to be changed without the need to walk on the top of the discharge.

The heads were changed and after the first sampling period of two shears had been completed. Figure 7.4 shows BSL discharge pump and head placement for sampling.

## CHAPTER SEVEN

### Field Trials In Australian Longwalls

---

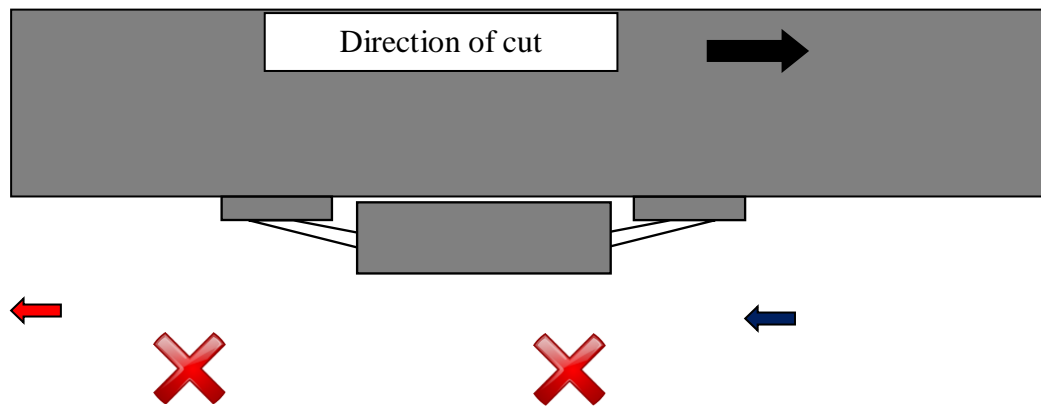


**Figure 7.4 Mine A Pump and Head Location at BSL Discharge**

#### **7.1.2.4 Pump and Head Location for Shearer Dust**

To sample accurate dust loads generated from the shearer, sampling will need to be done on both the maingate drum and the tailgate drum. Mine A utilises a modified uni-di cutting system which incorporates the tail gate drum cutting 500mm lower than the maingate drum on the tail to main cut.

The placement of the pumps and heads posed some problems as sampling needed to be done as close to the source of generation as possible to minimise the chance of sample contamination and maximise dust load capture. For this to occur, the pumps and heads were attached to shearer driver and chock operators. Figure 7.5 denotes personal sampling locations for measurement of shearer produced dust.

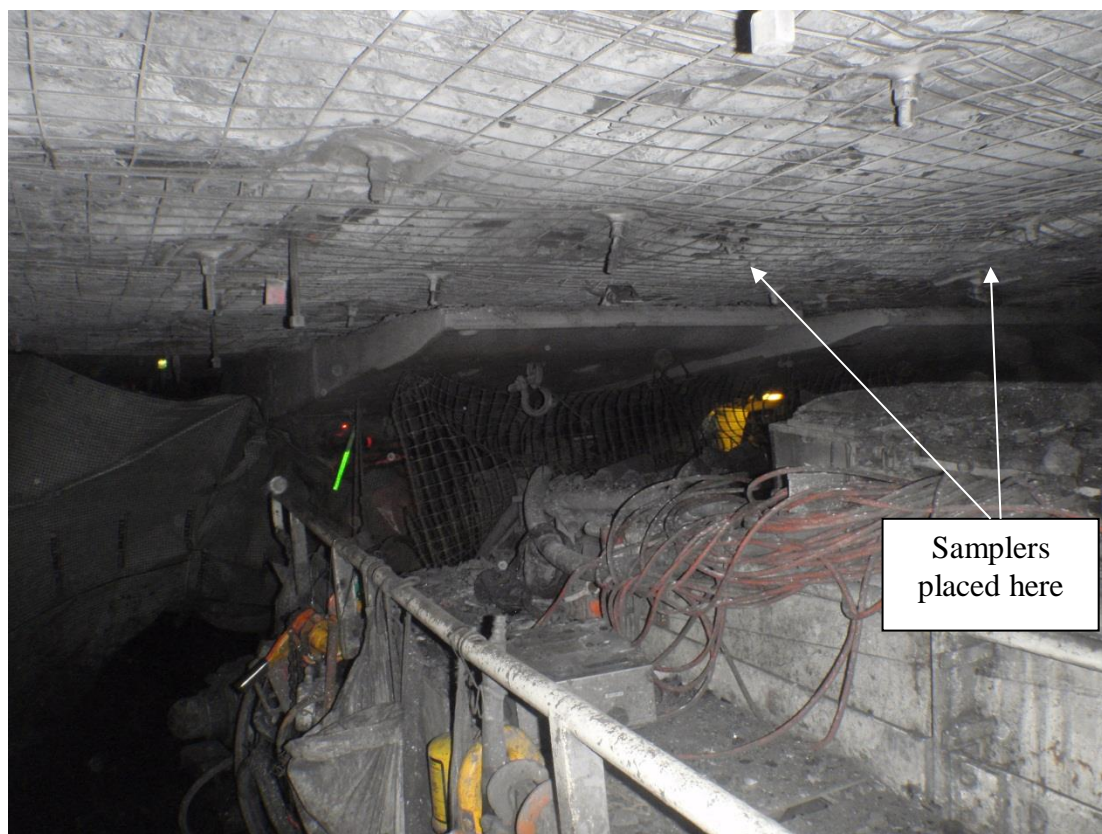


**Figure 7.5 Mine A Location of Personal Samplers**

### **7.1.2.5 Pump and Head Location for Crusher**

Pumps and heads were placed on the top or side of the crusher, depending on ease of installation, approximately 500mm inbye of the crusher intake. This will allow the sampling of crusher generated dust that may escape from the crusher mouth into the intake ventilation at the maingate. They may be mounted on the maingate chock. Figure 7.6 denotes monitor and head positioning on the crusher.





**Figure 7.6 Mine A Pump and Head Location Over Crusher Intake**

#### **7.1.2.6 Pump and Head Location for Crusher and BSL**

Pumps and heads were placed in the maingate area on the underside of the maingate chock, before the ventilation enters the longwall. These pumps and heads were used to sample intake contamination from inadequately sealed BSL's and crushers. The pump and head placement in the intake travel and belt roads, the BSL discharge and the crusher will allow determination of the dust loads from each of those sources and these Figures combined can be taken away from the dust loads from the maingate pump and heads, giving a dust load escaping from the inadequately sealed BSL and crusher.

Figure 7.7 denotes the positioning of the monitors and heads to sample dust loads from inadequately sealed crusher and BSL.

## CHAPTER SEVEN

### Field Trials In Australian Longwalls

---



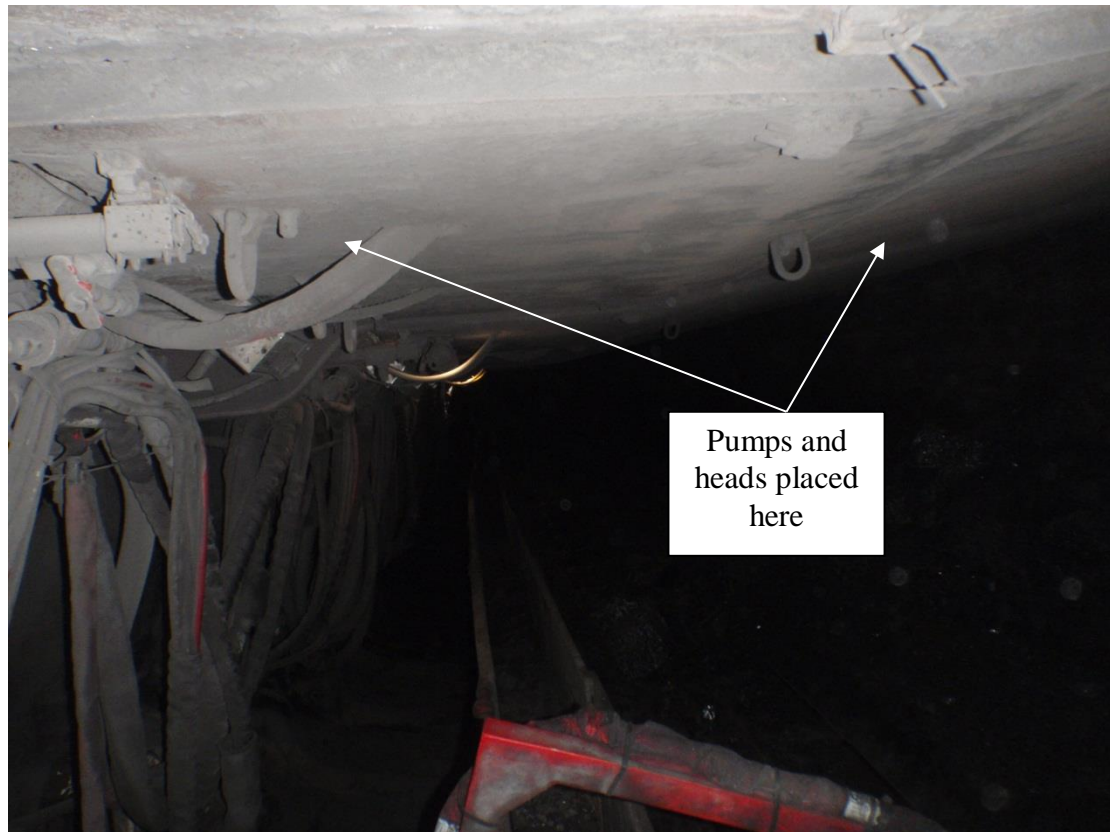
**Figure 7.7 Mine A Pump and Head Location for Inadequate Crusher and BSL Sealing**

The monitors were hung from the maingate chock in the intake ventilation ensuring the pumps and heads were safe from damage during chock movement.

#### **7.1.2.7 Pump and Head Location for Chock Dust**

This sampling methodology has the opportunity to fully measure dust loads generated during chock movement. The monitors will be hung from the underside of the chock. By placing the pumps and heads every 20 chocks, analysis will be able to quantify where and during what sequence, the most dust is generated, and where contaminated ventilation that has entered via the maingate will re-enter the longwall.

Figure 7.8 denotes position of monitors and heads on the underside of the chocks to monitor dust generated during movement.



**Figure 7.8 Mine A Placement of Pumps and Heads on the Underside of Chocks**

#### **7.1.2.8 Pump and Head Location for Total Dust**

Sampling the total dust loads produced was obtained by placing monitors on the tailgate chock, or chock 139 before the methane dilution wing. These monitors will sample the full dust loads generated from all sources on the longwall. Figure 7.9 denotes the location of the pumps and heads to sample total face dust.



**Figure 7.9 Mine A Pump and Head Location in the Tailgate**

### 7.1.3 Mine A Installed Engineering Controls

Table 7.3 details the installed engineering controls on Mine A longwall.

**Table 7.3 Mine A Installed Engineering Controls**

<b>BSL discharge</b>	
Number of sprays in BSL discharge	2 plus 1 cluster spray
Type: Solid, Hollow cone, Flat, V	Hollow cone
Spray Diameter	6 and 8mm
Water Pressure	20Bar
Water Flow	NA
<b>BSL Sprays</b>	
Number of sprays	12
Type: Solid, Hollow cone, Flat, V	Hollow Cone
Spray Diameter	6mm
Water Pressure	20Bar
Water Flow	NA
<b>BSL crusher</b>	
Number of sprays	12

## CHAPTER SEVEN

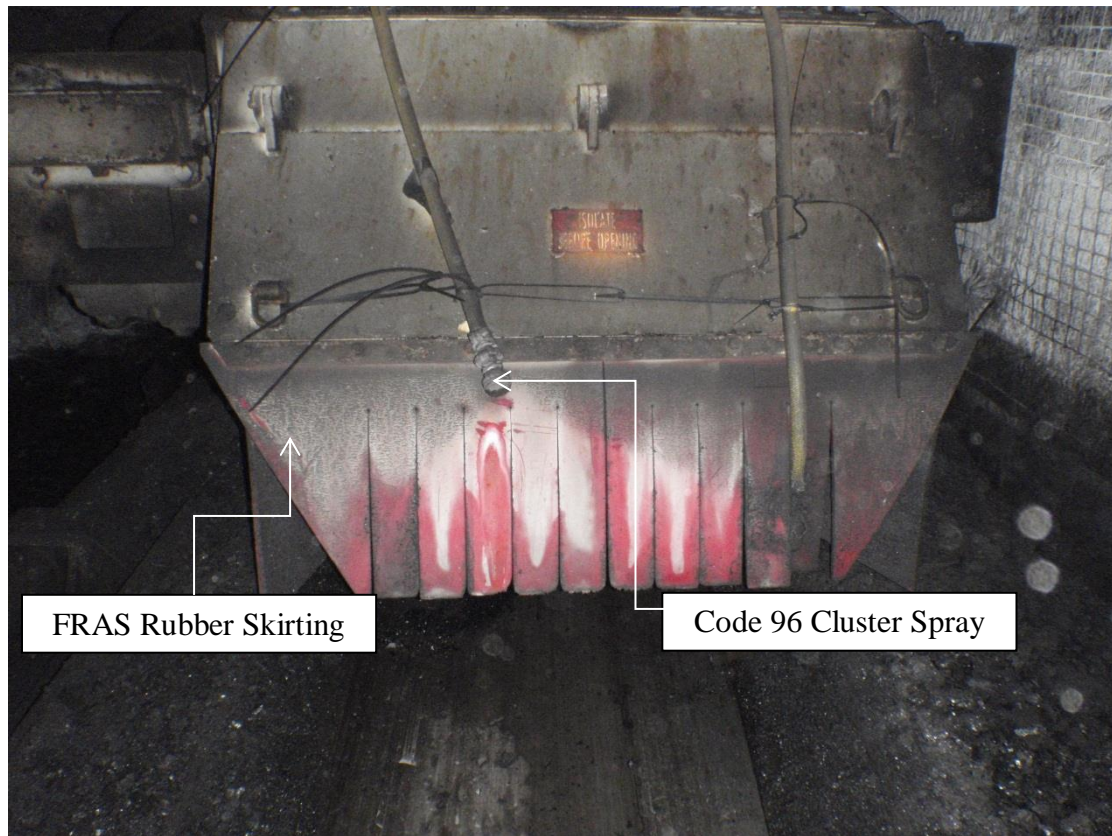
### Field Trials In Australian Longwalls

Type: Solid, Hollow cone, Flat, V	Hollow Cone
Spray Diameter	6mm
Water Pressure	20Bar
Water Flow	NA
<b>Shearer</b>	
Number of sprays	84
Type: Solid, Hollow cone, Flat, V	Solid Cone
Spray Diameter	1.2mm
Water Pressure	65Bar
Water Flow	NA
Types of Picks	Radial
<b>Shearer Clearer</b>	Not Operating
<b>Other Dust Controls Used?</b>	AFC Sprays in Maingate. BSL Scrubber

#### 7.1.3.1 Installed Controls in the BSL Discharge

The BSL discharge has the traditional FRAS rubber skirting arrangement between the bottom of the discharge for the coal discharge onto the outbye belt. Inside the discharge hood is two 6mm solid cone sprays and on the outside is a code 96 Conflow Cluster spray.

Figure 7.10 shows the FRAS rubber skirting from the BSL discharge to the outbye belt and the code 96 cluster spray. Figure 7.11 shows the code 96 Cluster Spray and Figure 7.12 shows the solid cone sprays located inside the discharge hood.



**Figure 7.10 Mine A BSL Discharge Skirting and Code 96 Cluster Spray**



**Figure 7.11 Mine A Code 96 Cluster Spray**



**Figure 7.12 Mine A Spray Inside Discharge Hood**

### **7.1.3.2 Installed Controls in the Crusher and BSL**

The Mine A crusher and BSL are fully enclosed, have conveyor belting at the crusher intake, two strips before the crusher and skirts on the BSL discharge to the outbye belt as detailed in 7.1.3.1 . Figure 7.13 shows the conveyor belt on the intake to the crusher at the maingate.



**Figure 7.13 Mine A Rubber Skirting at Intake to Crusher**

Figure 7.14 shows the conveyor belt strips inside the crusher before the hammers.



**Figure 7.14 Mine A Rubber Strips Before Crusher**



## CHAPTER SEVEN

### Field Trials In Australian Longwalls

---

Figure 7.15 shows the hollow cone sprays inside the crusher in two rows of three between the conveyor skirts. It should be noted that the sprays are installed at approximately 45 degrees toward the crusher. The sprays use 35-45 lpm each at a pressure of 12 to 20 Bar.

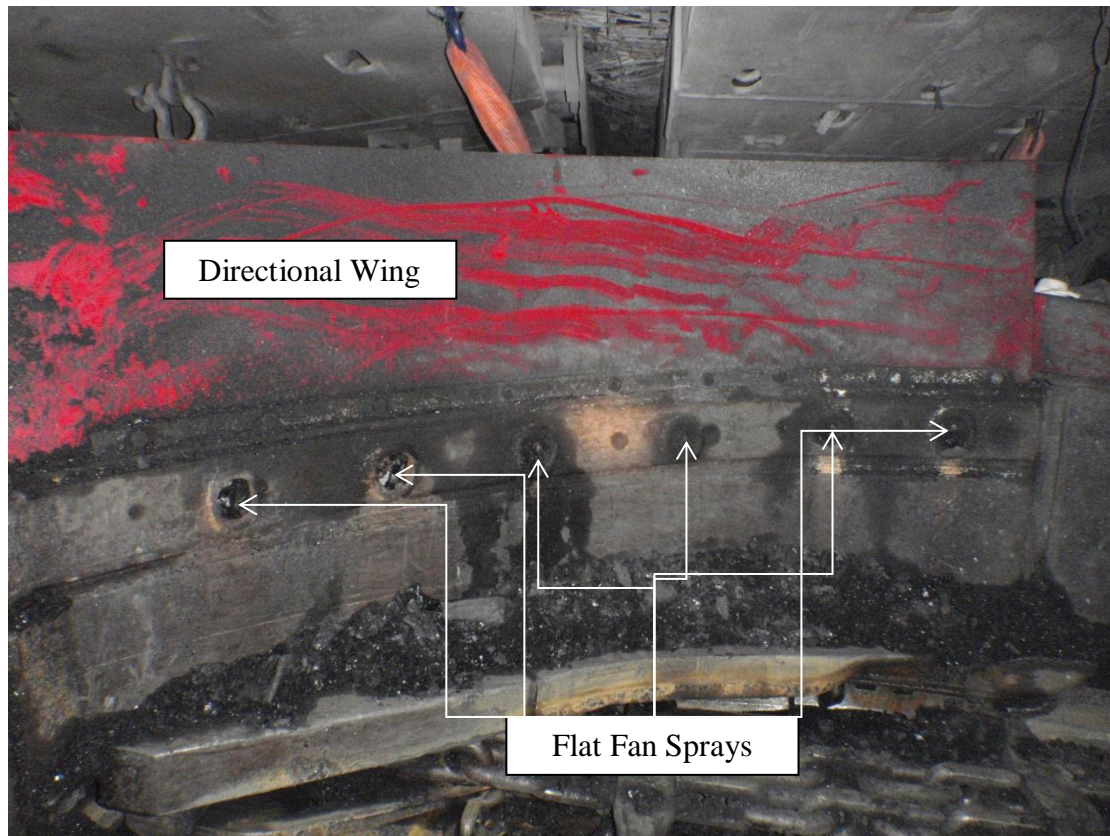


**Figure 7.15 Mine A Installed Sprays Before Crusher**

Mine A has also installed sprays on the transfer from the face AFC to the crusher intake and these are Spraying Systems flat fan sprays with a 2mm orifice designed to stop the dust billowing into the intake air. There are 6 sprays installed on the AFC wall along with a FRAS wing acting as a directional Barrier for fugitive dust forcing contaminated air down the face instead of along the walkway. Figure 7.16 shows the spray setup to suppress dust from the face to crusher intake and the directional wing.

## CHAPTER SEVEN

### Field Trials In Australian Longwalls



**Figure 7.16** Mine A Flat Fan Sprays at AFC/Maingate Transfer and Directional Wing

#### 7.1.3.3 BSL Scrubber

Mine A has an electric drive dust extractor fitted to the BSL. The scrubber has suction duct attached to both the crusher and the BSL discharge hood, with suction quantities determined by an adjustable butterfly valve. At the time of the testing, this unit was not operating. Figure 7.17 shows the installed BSL scrubber.

## CHAPTER SEVEN

### Field Trials In Australian Longwalls

---

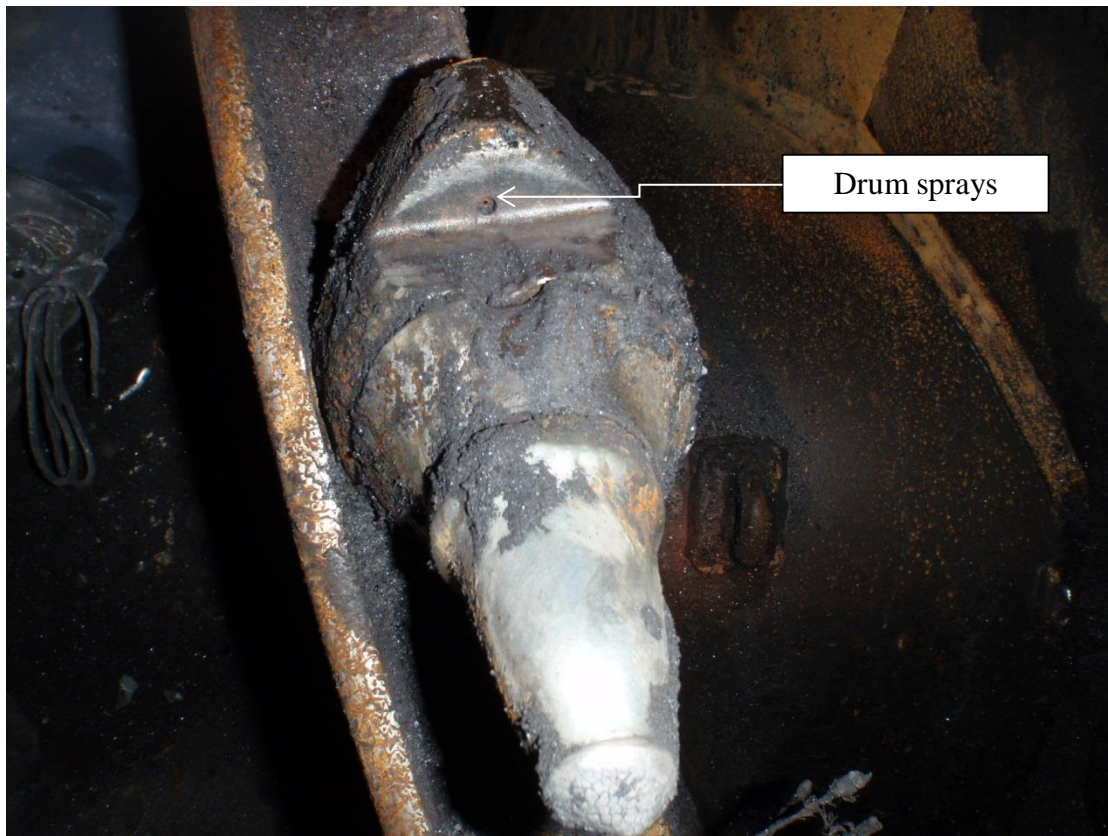


**Figure 7.17 Mine A Installed BSL Scrubber**

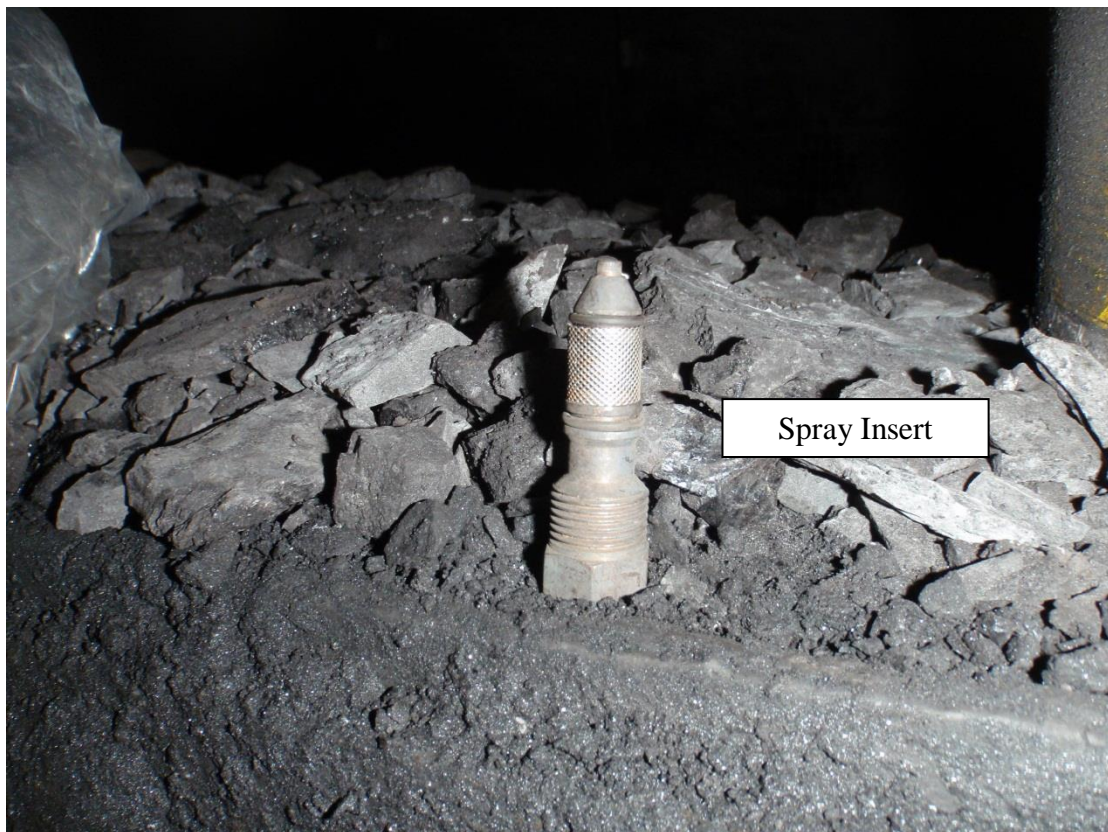
#### **7.1.3.4 Shearer Dust Controls**

Drum mounted water sprays are the first point dust suppression process on the shearer cutting drum. The sprays are pointed directly at the pick point of coal fracture and add moisture to minimize dust liberation. Optimum pressure to the sprays is usually 20-30 Bar, the sprays are full cone spray pattern and there are 84 sprays on the drum.

Figure 7.18 shows the location of the spray behind the pick and Figure 7.19 shows the spray insert used.



**Figure 7.18 Mine A Installed Drum Sprays Behind Pick**



**Figure 7.19 Mine A Drum Spray Insert**

## CHAPTER SEVEN

### Field Trials In Australian Longwalls

---

#### 7.1.3.5 Other Dust Controls

Mine A has installed two “rocket sprays” at chock #5 and chock #10. These are made of a FRAS L-shaped material fixed to the walkway side of the panline and can swivel out of the way of the bretby as it passes by. The spray is a fire hose type fitting and is designed to spray water onto the AFC in a large fan pattern, preventing dust from entering the walkway as coal is conveyed into the crusher. Pressure and flow characteristics of these sprays are unknown. Figure 7.20 shows the installed “rocket sprays”.



**Figure 7.20 Mine A “Rocket Sprays”**

Mine A also has chock sprays installed but these are not used. Figure 7.22 shows the installed chock sprays.

## CHAPTER SEVEN

### Field Trials In Australian Longwalls

---



**Figure 7.21 Mine A Installed Chock Sprays**

## **7.2 Field Study Mine B**

Mine B was the second mine to undertake the field study with the data being collected by Coal Services for the first set of samples taken. Instructions relating to pump and head placement were detailed by the author and data was collected as per the collection process detailed in Chapter 6. Raw data results, ie the measured difference between the pre weighed filter and the post weighed filter, were received by the author after completion of the field trial by Coal Services. This raw data was analysed utilising the Dust Mitigation Efficiency formula detailed in section 6.3.7.

Additional testing was undertaken at Mine B with the data being collected by the author. This data collection process is detailed in chapter 6.

### **7.2.1 Operational Parameters of Mine B**

Table 7.4 details the operating parameters of Mine B.

## CHAPTER SEVEN

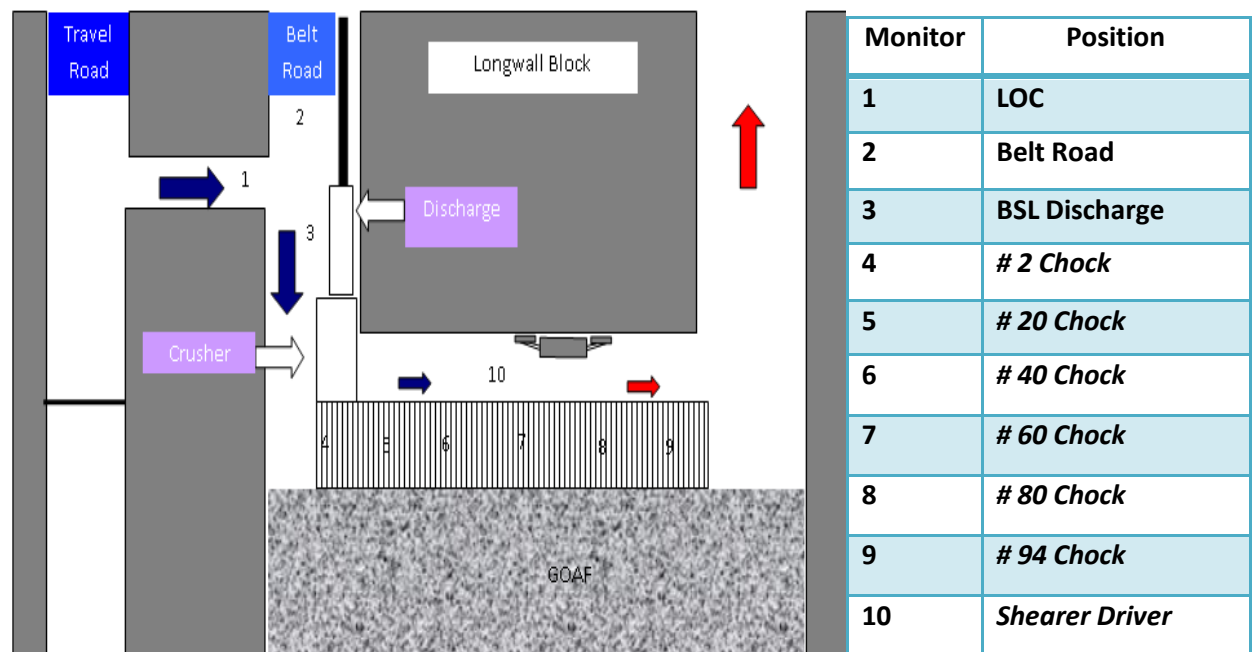
### Field Trials In Australian Longwalls

**Table 7.4 Mine B Operating Parameters**

<b>State/Coalfield</b>	New South Wales/Southern
<b>Seam/Working thickness, metres (m)</b>	Bulli/ 2.8-3.2m
<b>Coal Type</b>	Coking
<b>Depth of cover, metres (m)</b>	450-500m
<b>Marketable reserves, proved and probable, million tonnes (Mt)</b>	76Mt
<b>Longwall operations (weekly)</b>	3 x 9.5hr shifts, 4 days; 2 x 12hr shifts, 3 days; 17 unit shifts
<b>Other operations (weekly)</b>	3 x 9.5hr shifts, 4 days; 2 x 12hr shifts, 3 days; 45 unit shifts
<b>Raw coal output 2011, tonnes</b>	
Longwall face, tonnes	1,806,400
Other, tonnes	149,100
Total, tonnes	1,955,500
Forecast total raw coal output 2012, tonnes	2,100,375
Longwall face raw coal output 2010-11, tonnes	1,968,399
Total mine raw coal output 2010-11, tonnes	2,187,566
<b>Commenced longwall mining</b>	Jul-95
<b>Longwall block dimensions 2011</b>	
Width, metres (m)	154m, 154m
Length, metres (m)	2800m, 3000m
<b>Shearer manufacturer</b>	Bucyrus
Type	Electra EL 2000 DERDS
Drum diameter, metres (m)	M/G 2m, T/G 2m
<b>Cutting height, metres (m)/ Method/ Web depth, millimetres (mm)</b>	2.8-3.2m, Uni-di Half Web, 800mm
<b>Install power, kilowatts (kW)</b>	1000kW
<b>Roof support manufacturer</b>	Bucyrus
Type/Number of supports	2-leg chock chock, 80, 21
Yield load, tonnes (t) Working range, metres (m) Control	750t, 720t, 2.2m-3.6m, PM4
<b>Face conveyor manufacturer</b>	Bucyrus
Width, millimetres (mm) Chain size, millimetres (mm)	932mm PF4, 30mm twin-in-board
Chain speed metres per second (m/s) Manufacturer	0.97m/s, THIELE
Motors, kilowatts (kW)	1 x 430kW
<b>Beam stage loader manufacturer kilowatts (kW)</b>	Bucyrus, PF4/932mm, 125kW
<b>Coal crusher manufacturer, kilowatts (kW)</b>	Bucyrus, KSB63, 125kW
<b>Coal clearance (to surface) type, Capacity, tonnes per hour (tph)</b>	Conveyor, 650tph
<b>Ventilation on Longwall</b>	35m <sup>3</sup> /sec

## 7.2.2 Pump and Head Location Mine B

Placement of the pumps and gravimetric heads will be at the last open cut-through before the ventilation enters the longwall, the belt road, BSL discharge, chocks 2, 20,40,60,80 and the tailgate chock 94. For this testing the shearer operator was also tested. Figure 7.22 denotes pump and head positioning for this field trial.



**Figure 7.22 Mine B Pump and Head Location**

### 7.2.2.1 Pump and Head Location in Last Open Cut-through

The monitors and gravimetric heads were placed in the last open cut-through before the ventilation enters the longwall to measure dust entering the longwall from outbye travel roads. Figure 7.23 denotes the positioning of pumps and heads in the last open cut-through.

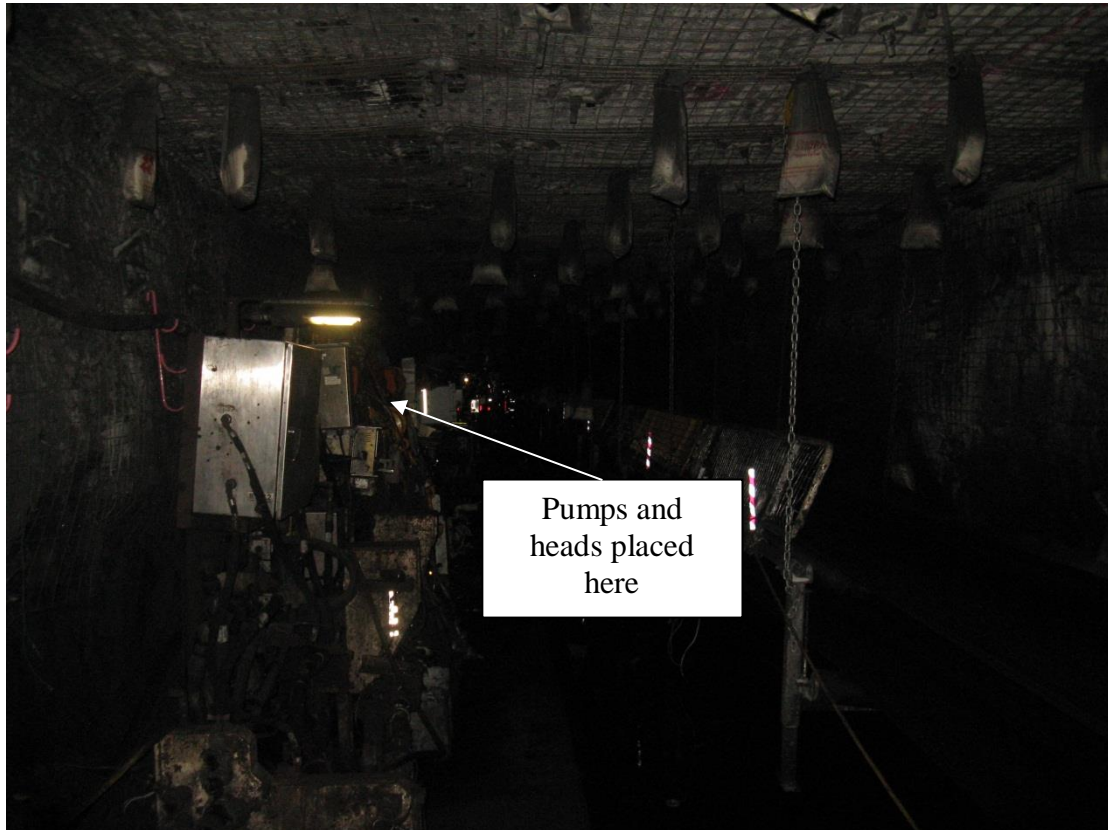




**Figure 7.23 Mine B Pump and Head Location in LOC**

### **7.2.2.2 Pump and Head Location in Belt Road**

The monitors and gravimetric heads were placed in the belt road to measure fugitive dust entering the longwall from the conveyor belt. Figure 7.24 denotes the positioning of pumps and heads in the belt road.

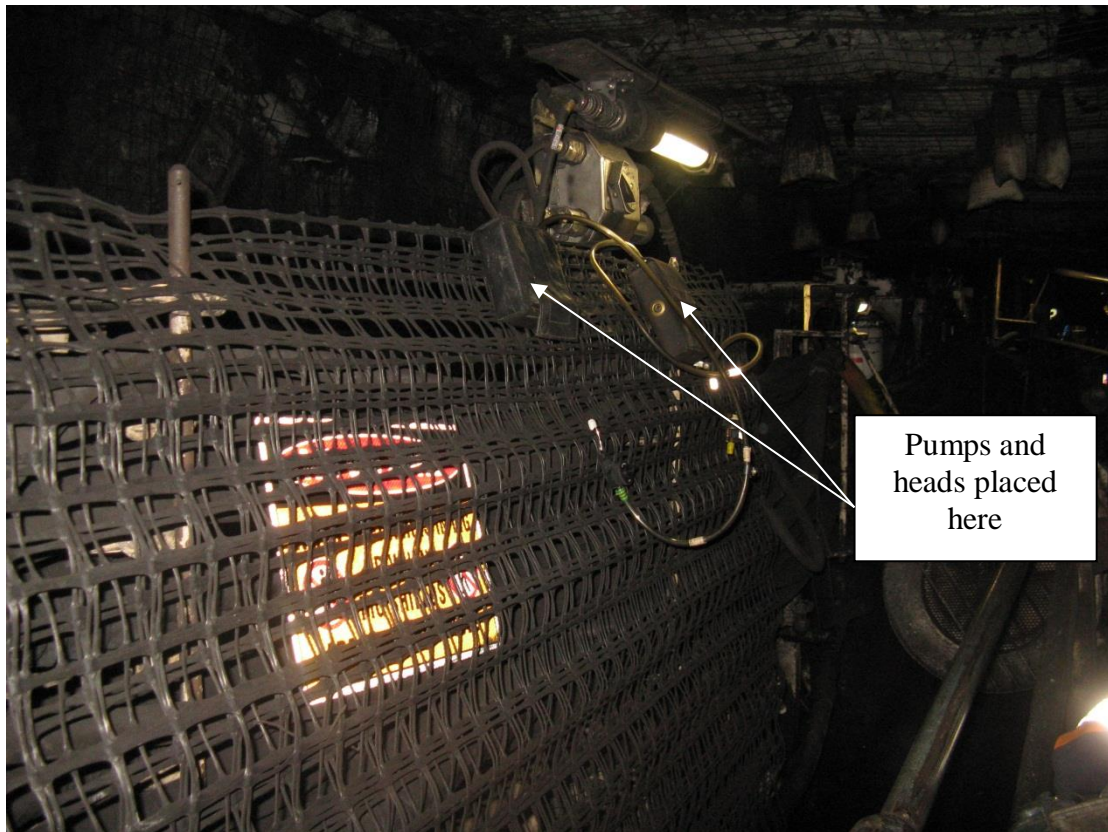


**Figure 7.24 Mine B Pump and Head Location in the Belt Road**

### **7.2.2.3 Pump and Head Location at BSL Discharge**

Sampling monitors and heads were placed inbye from the BSL discharge to the outbye belt and hung from installed mesh.

The heads were changed and after the first sampling period of two shears had been completed. Figure 7.25 shows BSL discharge pump and head placement for sampling.



**Figure 7.25 Mine B Pump and Head Location at BSL Discharge**

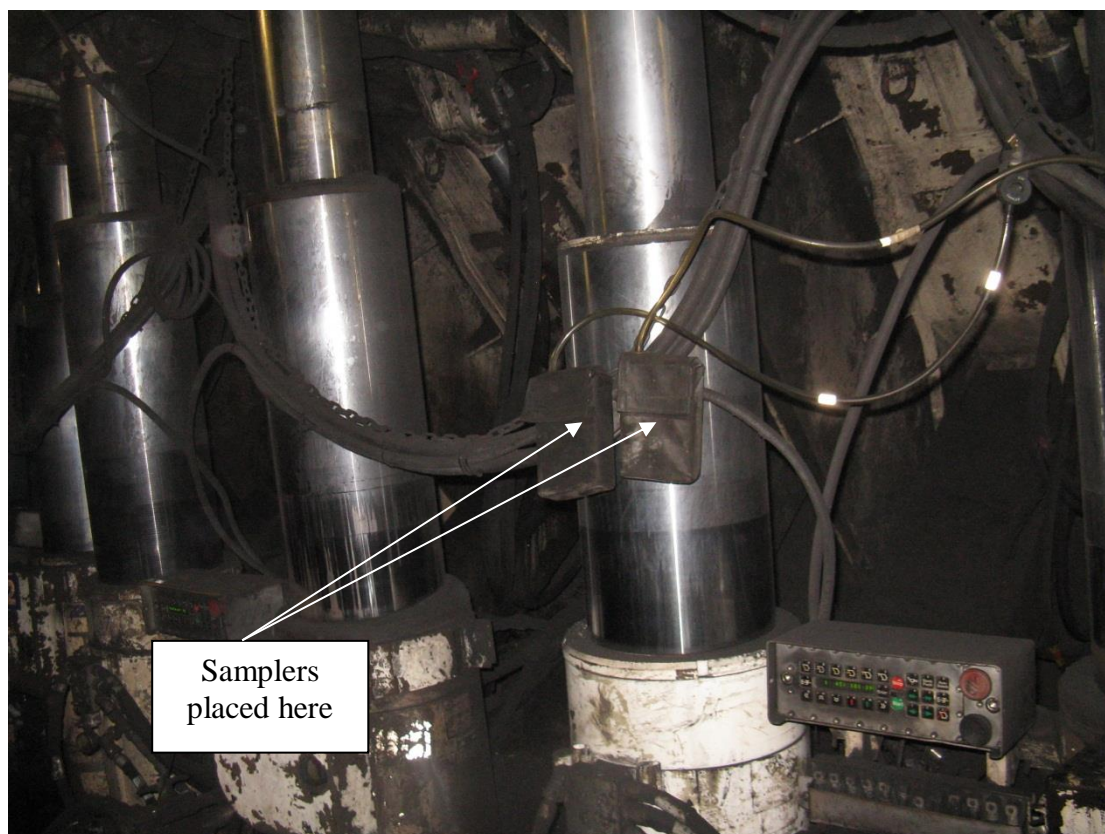
#### **7.2.2.4 Pump and Head Location for Crusher Dust**

Pumps and heads were placed on chock #2 to sample crusher generated dust that may escape from the crusher mouth into the intake ventilation at the maingate. The pumps and heads were mounted on hosing the control box. Figure 7.26 shows pump and head positioning on chock #2 to sample fugitive crusher dust.

## CHAPTER SEVEN

### Field Trials In Australian Longwalls

---



**Figure 7.26 Mine B Pump and Head Location for Crusher Dust on Chock #2**

#### **7.2.2.5 Pump and Head Location for Shearer Dust**

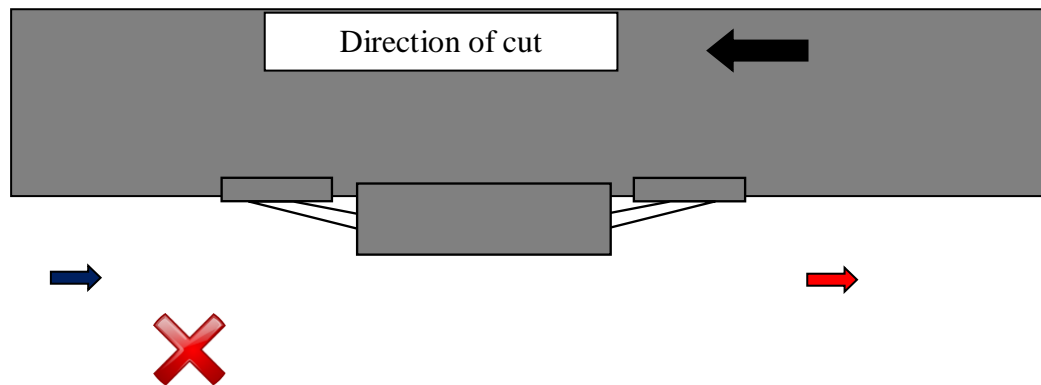
To sample accurate dust loads generated from the shearer, sampling will need to be done on both the maingate drum and the tailgate drum. Mine B utilises a modified uni-di cutting system which incorporates the tailgate drum cutting 500mm lower than the maingate drum on the tail to main cut.

The placement of the monitor and head posed some problems as sampling needs to be done as close to the source of generation as possible to minimise the chance of sample contamination and maximise dust load capture. For this to occur, the monitors were attached to shearer driver. Figure 7.27 denotes personal sampling location.

## CHAPTER SEVEN

### Field Trials In Australian Longwalls

---



**Figure 7.27 Mine B Location of Personal Samplers**

#### **7.2.2.6 Pump and Head Location for Chock Dust**

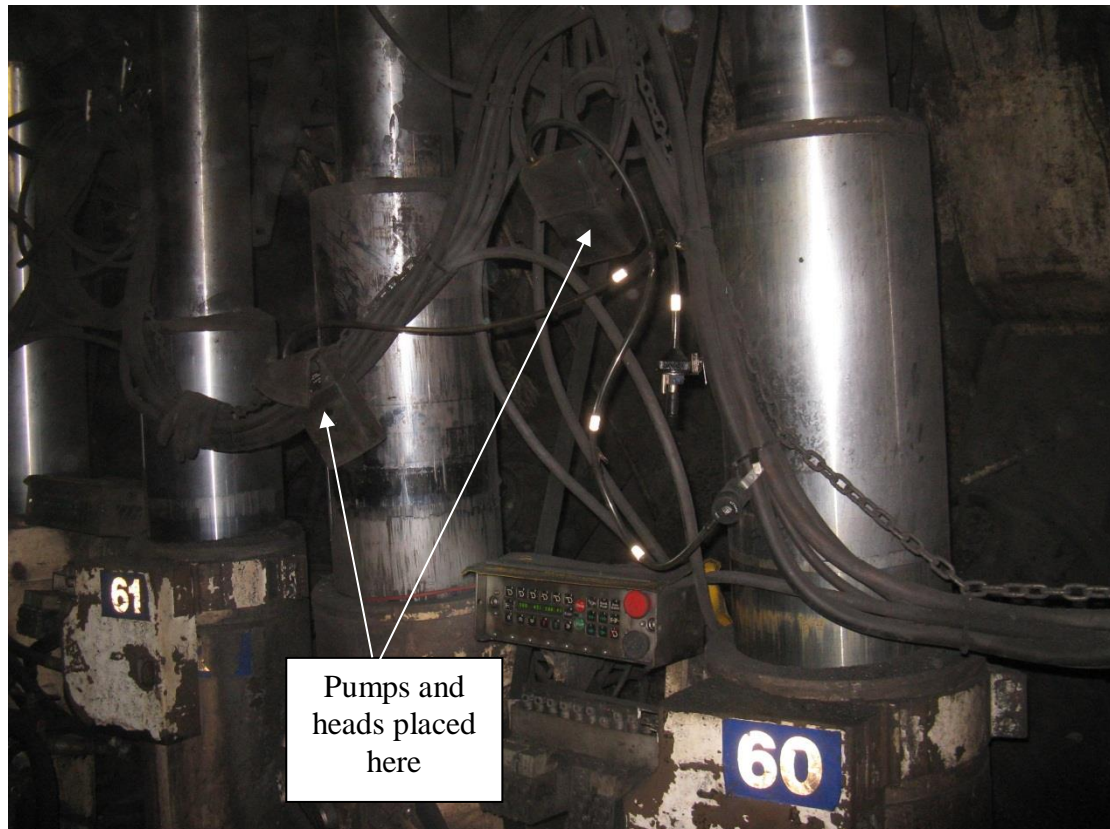
This sampling methodology has the opportunity to fully measure dust loads generated during chock movement. The monitors will be hung from the underside of the chock. By placing the pumps and heads every 20 chocks, analysis will be able to quantify where and during what sequence, the most dust is generated, and where contaminated ventilation that has entered via the maingate will re-enter the longwall.

Figure 7.28 denotes position of monitors and heads on the chocks to monitor dust generated during movement.

## CHAPTER SEVEN

### Field Trials In Australian Longwalls

---



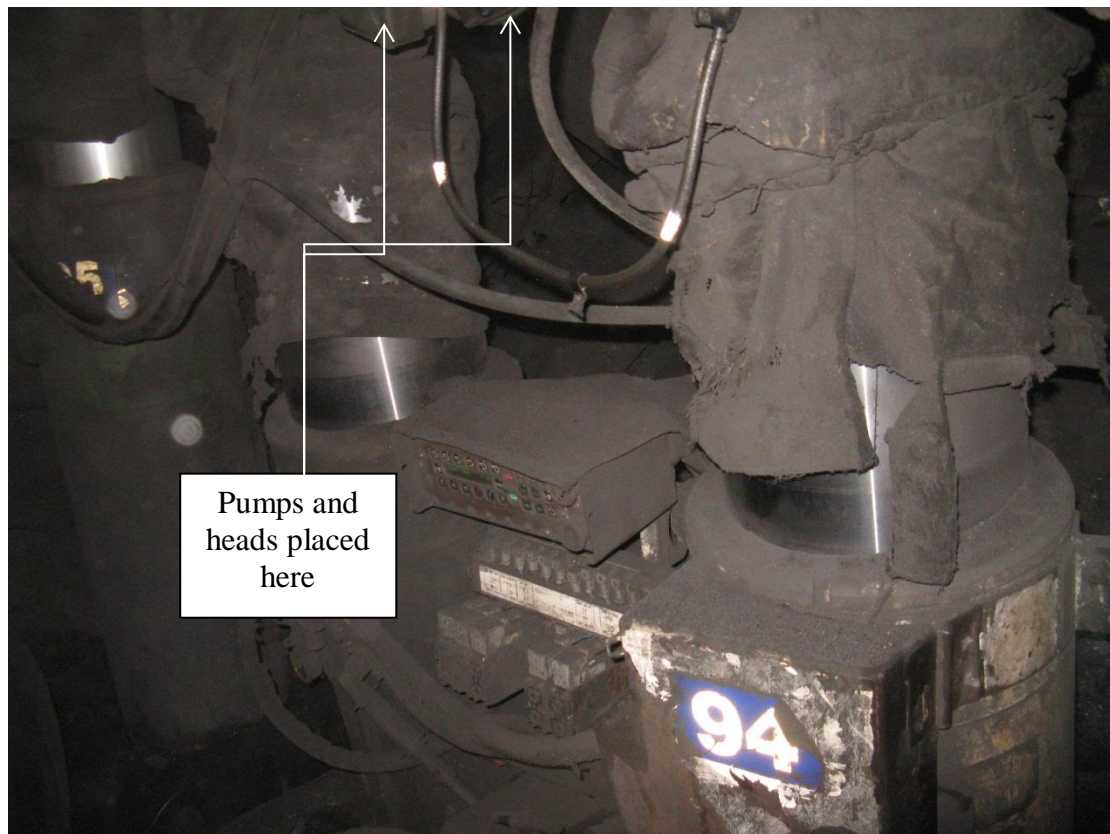
**Figure 7.28 Mine B Placement of Pumps and Heads on Chocks**

#### **7.2.2.7 Pump and Head Location for Total Dust**

Sampling the total dust loads produced was obtained by placing monitors on the tailgate chock, or chock 94. These monitors will sample the full dust loads generated from all sources on the longwall. Figure 7.29 shows the location of the pumps and heads to sample total face dust.

## CHAPTER SEVEN

### Field Trials In Australian Longwalls



**Figure 7.29 Mine B Pump and Head Location in the Tailgate**

### 7.2.3 Mine B Installed Engineering Controls

Table 7.5 details the installed engineering controls on Mine B longwall.

**Table 7.5 Mine B Installed Engineering Controls**

<b>BSL discharge</b>	
Number of sprays in BSL discharge	3
Type: Solid, Hollow cone, Flat, V	Hollow Cone
Spray Diameter	6mm
Water Pressure	15Bar
Water Flow	NA
<b>BSL Sprays</b>	
Number of sprays	12
Type: Solid, Hollow cone, Flat, V	Hollow Cone
Spray Diameter	6mm
Water Pressure	15Bar
Water Flow	NA
<b>BSL crusher</b>	
Number of sprays	12
Type: Solid, Hollow cone, Flat, V	Hollow Cone
Spray Diameter	6mm

## CHAPTER SEVEN

### Field Trials In Australian Longwalls

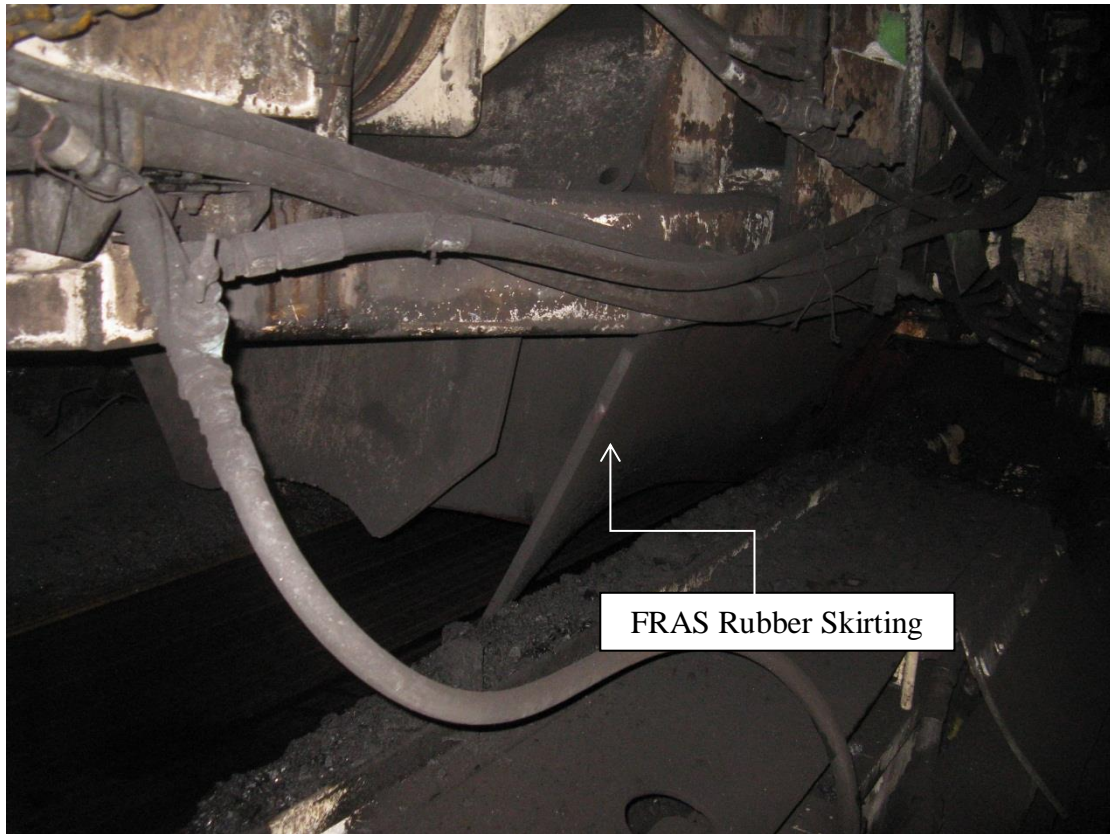
Water Pressure	15Bar
Water Flow	NA
<b>Shearer</b>	
Number of sprays	64
Type: Solid, Hollow cone, Flat, V	Solid Cone
Spray Diameter	1.2mm
Water Pressure	65Bar
Water Flow	475lpm
Types of Picks	Radial
<b>Shearer Clearer</b>	None
<b>Chock Sprays</b>	
Number of sprays	2 per chock
Type: Solid, Hollow cone, Flat, V	Hollow Cone
Spray Diameter	1.2mm
Water Pressure	60Bar
Water Flow	100lpm
<b>Other Dust Controls Used?</b>	BSL Scrubber
Shearer drum speed	30rpm
Shearer Speed	5-8m/minute
Av. Shears per Shift	4
Av. Tonnes per Shear	650

#### 7.2.3.1 Installed Controls in the BSL Discharge

The BSL discharge has the traditional FRAS rubber skirting arrangement between the bottom of the discharge for the coal discharge onto the outbye belt. Inside the discharge hood is three 6mm solid cone sprays.

Figure 7.30 shows the FRAS rubber skirting from the BSL discharge to the outbye belt and Figure 7.31 shows the solid cone sprays located inside the discharge hood.





**Figure 7.30 Mine B BSL Discharge Skirting**



**Figure 7.31 Mine B Sprays inside Discharge Hood**

#### 7.2.3.2 Installed Controls in the Crusher and BSL

The Mine B crusher and BSL are fully enclosed, have conveyor belting at the crusher intake, two strips before the crusher and skirts on the BSL discharge to the outbye belt. Figure 7.32 shows the conveyor belt on the intake to the crusher at the maingate.



**Figure 7.32 Mine B Rubber Skirting at Intake to Crusher**

Figure 7.33 shows the hollow cone sprays fitted to a spray bar that is inserted into holes in the top of the crusher in two rows. The sprays use 35-45 lpm each at a pressure of 12 to 20 Bar. Figure 7.34 shows where the spray bars are inserted to spray into the crusher and Figure 7.35 shows the installed spray bar.



**Figure 7.33 Mine B Installed Sprays in Spray Bar in Crusher**

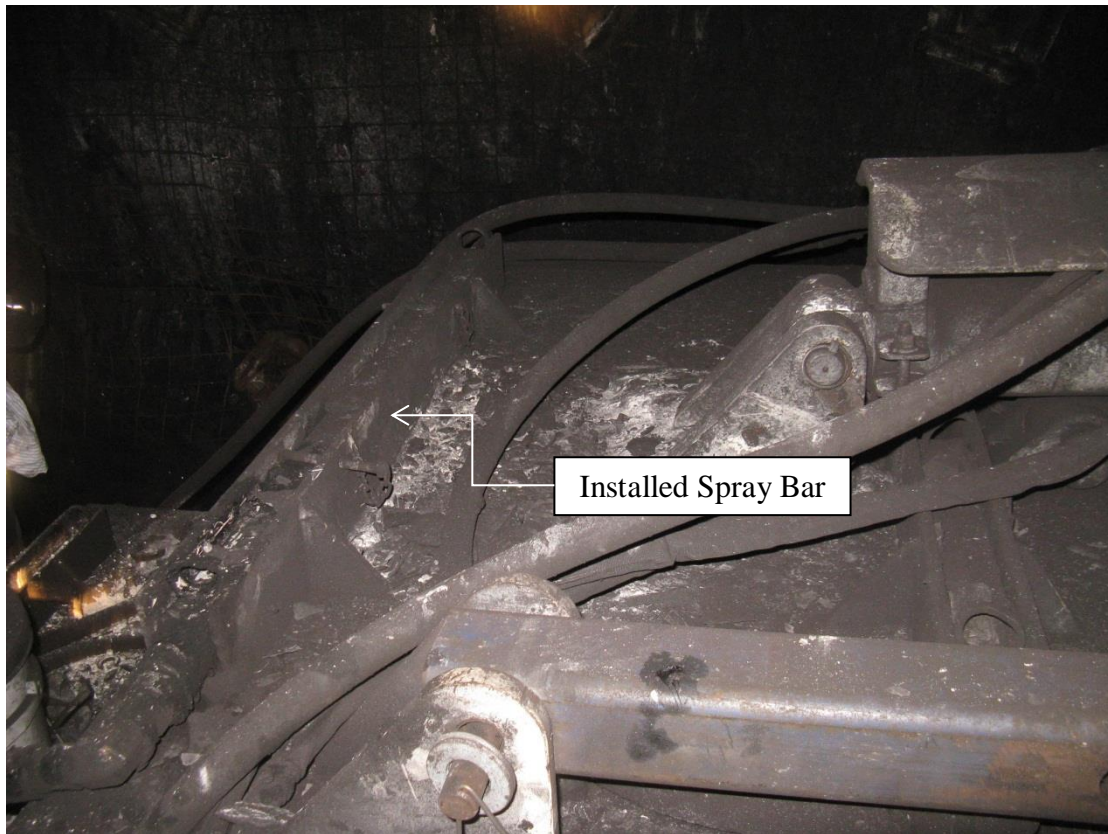


**Figure 7.34 Mine B Spray Bar Location Holes in Crusher**

## CHAPTER SEVEN

### Field Trials In Australian Longwalls

---



**Figure 7.35 Mine B Installed Spray Bar in Crusher**

Mine B has also installed a dropper spray arrangement with a code 96 cluster spray on the transfer from the face AFC to the crusher intake and at chock #5. There is also a FRAS wing acting as a directional Barrier for fugitive dust forcing contaminated air down the face instead of along the walkway. Figure 7.36 shows the dropper spray setup at the maingate, which is placed over the directional wing when operating. Figure 7.37 shows the installed code 96 cluster spray, Figure 7.38 shows the dropper spray located at chock #5 and Figure 7.39 shows the directional wing fitted to the maingate.



**Figure 7.36 Mine B Dropper Spray at Maingate and Directional Wing**



**Figure 7.37 Mine B Code 96 Fitted to Dropper Spray**



**Figure 7.38 Mine B Dropper Spray at Chock #5**



**Figure 7.39 Mine B Maingate Directional Wing**

### **7.2.3.3 BSL Scrubber**

Mine B has an electric drive dust extractor fitted to the BSL discharge. Figure 7.40 shows the installed BSL scrubber.

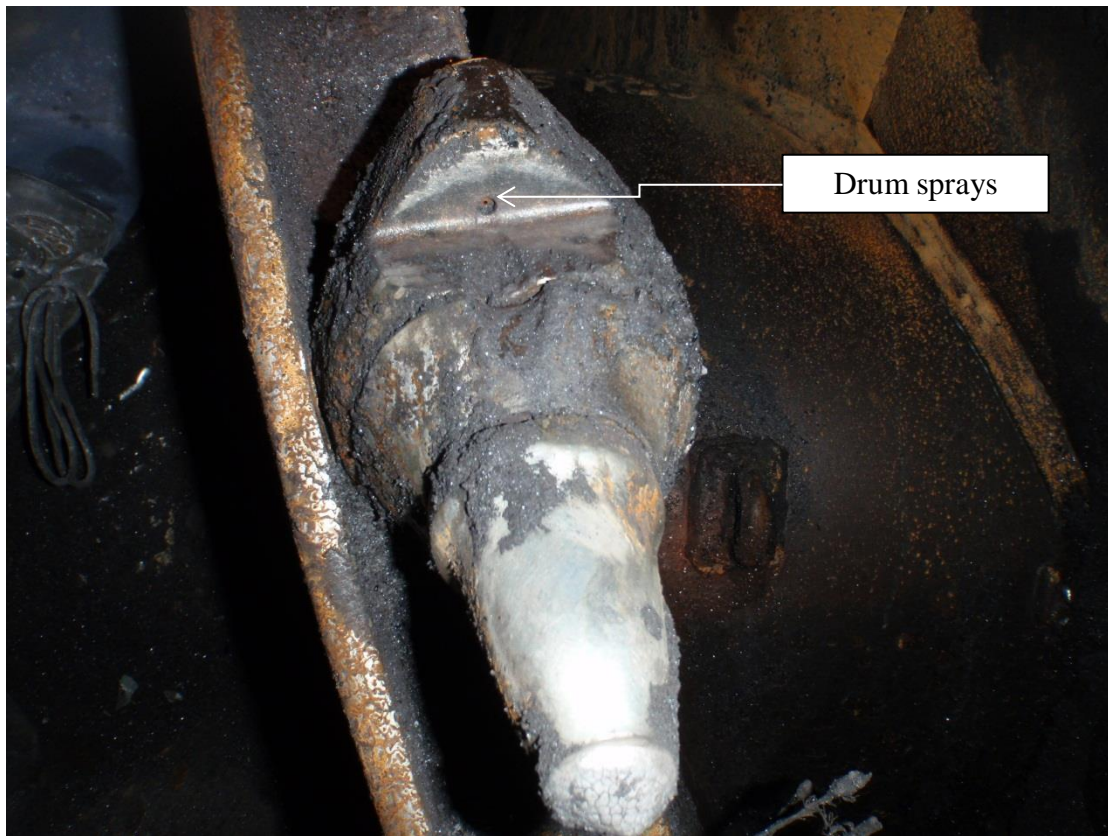


**Figure 7.40 Mine B Installed BSL Scrubber**

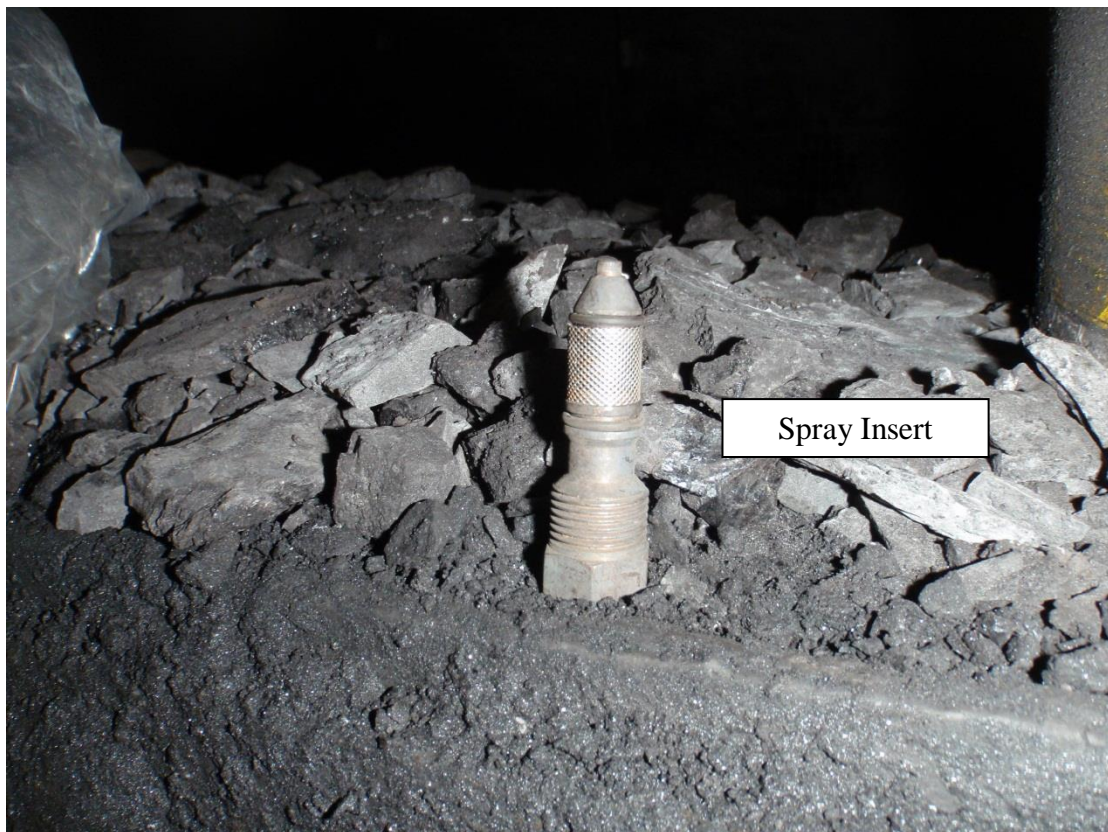
### **7.2.3.4 Shearer Dust Controls**

Drum mounted water sprays are the first point dust suppression process on the shearer cutting drum. The sprays are pointed directly at the pick point of coal fracture and add moisture to minimize dust liberation. Optimum pressure to the sprays is usually 20-30 Bar, the sprays are full cone spray pattern and there are 84 sprays on the drum.

Figures 7.41 shows the location of the spray behind the pick and Figure 7.42 shows the spray insert used.



**Figure 7.41 Mine B Installed Drum Sprays behind Pick**



**Figure 7.42 Mine B Drum Spray Insert**



#### 7.2.3.5 Other Dust Controls

Mine B has 2 chock sprays installed on every chock that are sequenced to come on as the shearer passes. They are positioned so as to stop face dust from rolling out into the walkway. The sprays are a hollow cone spray, 1.2mm orifice, use 100 lpm of water at 60 Bar of pressure. Figure 7.43 shows the installed chock sprays operating.



**Figure 7.43 Mine B Installed Chock Sprays**

### 7.3 Field Study Mine C

Mine C was the third mine to undertake the field study with the data being collected by the author. Multiple samples were taken at Mine C. Pump and head placement along with data collection was as per the collection process detailed in Chapter 6. Filter preparation for this testing was performed as detailed in section 6.3. This raw data was analysed utilising the Dust Mitigation Efficiency formula detailed in section 6.3.7.

## CHAPTER SEVEN

### Field Trials In Australian Longwalls

#### 7.3.1 Operational Parameters of Mine C

Table 7.6 details the operating parameters of Mine C.

**Table 7.6 Mine C Operating Parameters**

	<b>Mine C</b>
<b>State/Coalfield</b>	New South Wales/Southern
<b>Seam/Working thickness, metres (m)</b>	Bulli, 2.8-3.4m
<b>Coal Type</b>	Coking
<b>Depth of cover, metres (m)</b>	550-600m
<b>Marketable reserves, proved and probable, million tonnes (Mt)</b>	42Mt
<b>Longwall operations (weekly)</b>	3 x 9hr shifts, 4 days; 2 x 12hr shifts, 3 days; 16 unit shifts
<b>Other operations (weekly)</b>	3 x 9hr shifts, 4 days; 2 x 12hr shifts, 3 days; 42 unit shifts
<b>Raw coal output 2011, tonnes</b>	
Longwall face, tonnes	2,516,700
Other, tonnes	483,700
Total, tonnes	3,000,400
Forecast total raw coal output 2012, tonnes	3,520,000
Longwall face raw coal output 2010-11, tonnes	1,859,054
Total mine raw coal output 2010-11, tonnes	2,286,842
<b>Commenced longwall mining</b>	May-69
<b>Longwall block dimensions 2011</b>	
Width, metres (m)	319m, 319m
Length, metres (m)	2020m, 2316m
<b>Shearer manufacturer</b>	Joy
Type	7LS-2A DERDS
Drum diameter, metres (m)	M/G 2.25m & 1.9m, T/G 2.25m & 1.9m
<b>Cutting height, metres (m)/ Method/ Web depth, millimetres (mm)</b>	3.2m, Uni-di, Variable Web
<b>Install power, kilowatts (kW)</b>	1130kW
<b>Roof support manufacturer</b>	Joy
Type/Number of supports	2-leg chock chock, 180
Yield load, tonnes (t) Working range, metres (m) Control	1000t, 2.4-3.6m, Joy RS20
<b>Face conveyor manufacturer</b>	Joy
Width, millimetres (mm) Chain size, millimetres (mm)	1000mm, 48mm twin-in-board

## CHAPTER SEVEN

### Field Trials In Australian Longwalls

Chain speed metres per second (m/s) Manufacturer	1.68m/s, Parsons
Motors, kilowatts (kW)	2 x 855kW
Beam stage loader manufacturer kilowatts (kW)	Joy 1200mm, 375kW
Coal crusher manufacturer, kilowatts (kW)	Joy, 375kW
Coal clearance (to surface) type, Capacity, tonnes per hour (tph)	Conveyor, 1600tph
Ventilation on Longwall	38m <sup>3</sup> /sec

### 7.3.2 Pump and Head Location Mine C

Monitors and heads were placed on each independent source of dust generation, namely the last open cut-through' the belt road, inbye of the BSL discharge, chock number 5 and the tailgate. In each location, two monitors and two heads were placed to sample both respirable and inhalable dust loads. Figure 7.44 shows the location of pumps and heads for the testing.

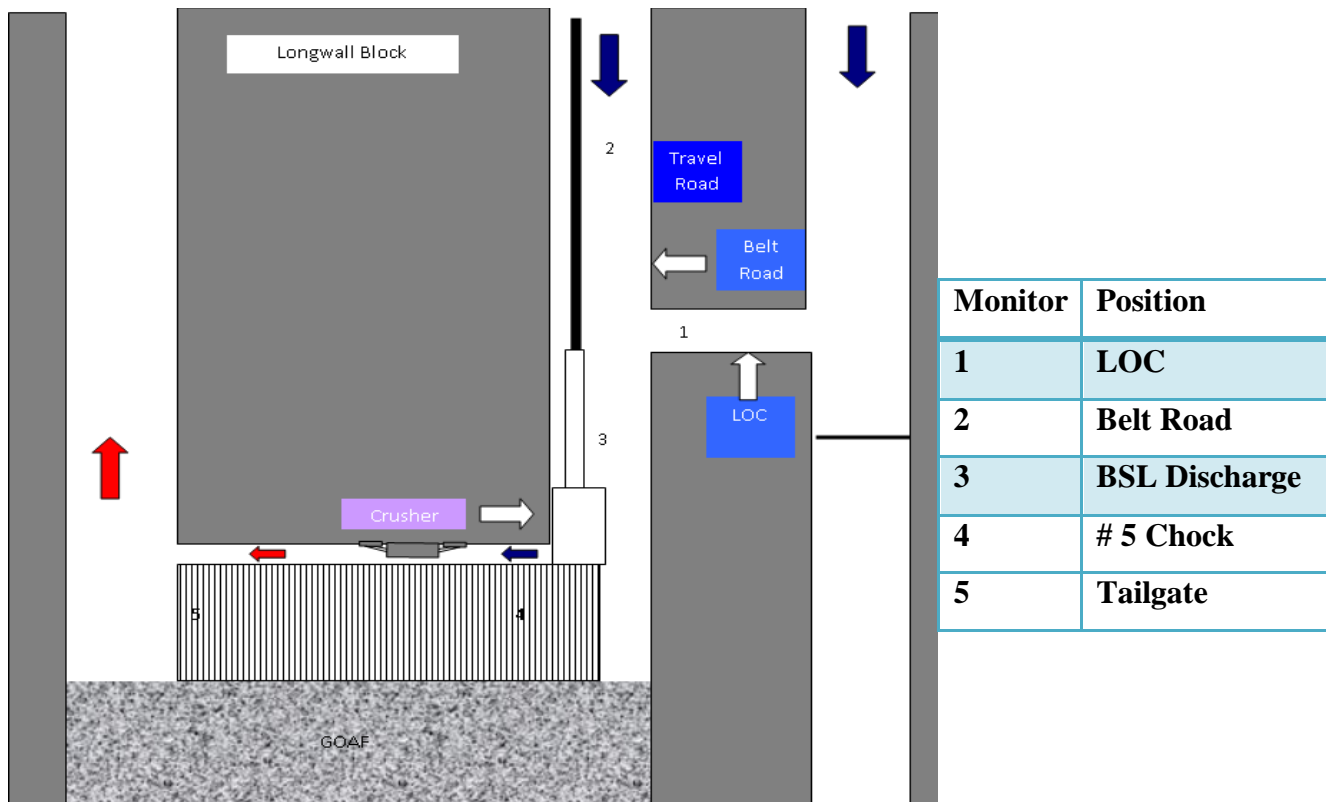


Figure 7.44 Mine C Pump and Head Location

### **7.3.2.1 Pump and Head Location in Last Open Cut-through**

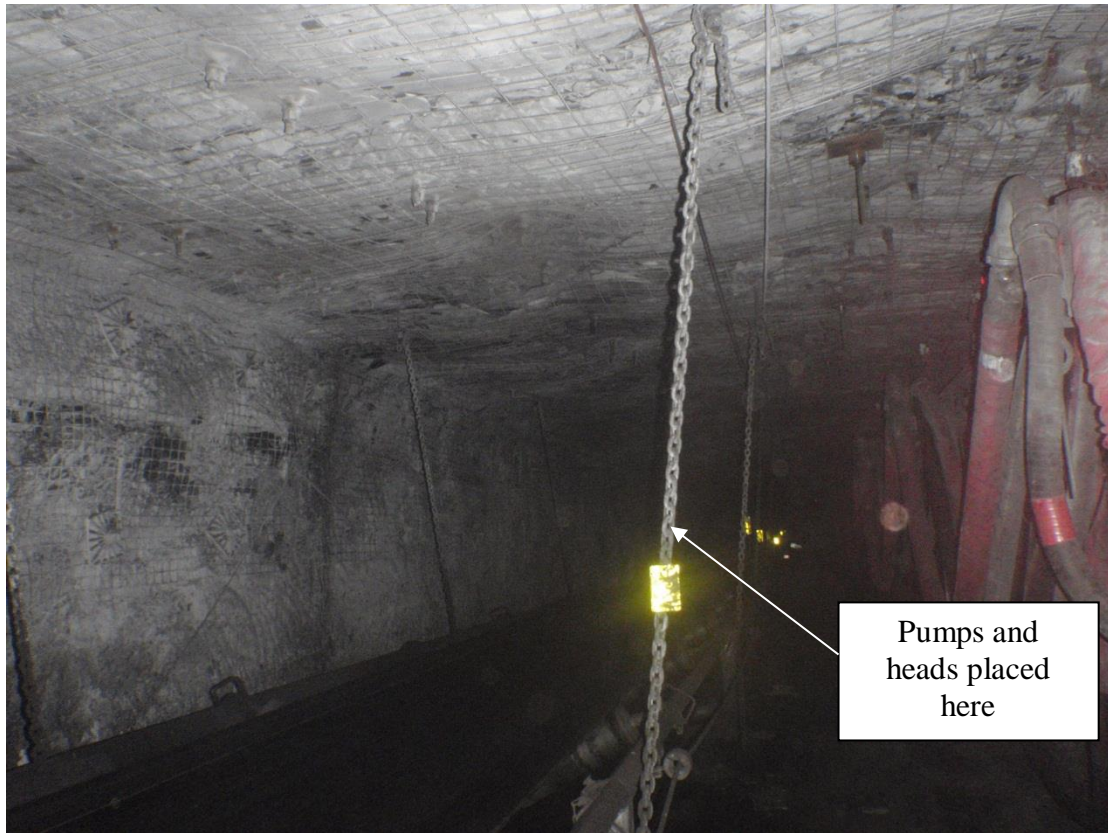
The monitors and gravimetric heads were placed in the last open cut-through before the ventilation enters the longwall to measure dust entering the longwall from outbye travel roads. Figure 7.45 shows the positioning of pumps and heads in the last open cut-through.



**Figure 7.45 Mine C Pump and Head Location in LOC**

### **7.3.2.2 Pump and Head Location in Belt Road**

The monitors and gravimetric heads were placed in the belt road to measure fugitive dust entering the longwall from the conveyor belt. Figure 7.46 shows the positioning of pumps and heads in the belt road.



**Figure 7.46 Mine C Pump and Head Location in the Belt Road**

### **7.3.2.3 Pump and Head Location at BSL Discharge**

Sampling monitors and heads were placed inbye from the BSL discharge to the outbye belt and hung from installed mesh.

The heads were changed and after the first sampling period of two shears had been completed. Figure 7.47 shows BSL discharge pump and head placement for sampling.



**Figure 7.47 Mine C Pump and Head Location Inbye of BSL Discharge**

#### **7.3.2.4 Pump and Head Location for Crusher**

Pumps and heads were placed on chock #5 to sample crusher generated dust that may escape from the crusher mouth into the intake ventilation at the maingate. The pumps and heads were mounted on hosing on the control box. Figure 7.48 shows pump and head positioning on chock #5 to sample fugitive crusher dust.



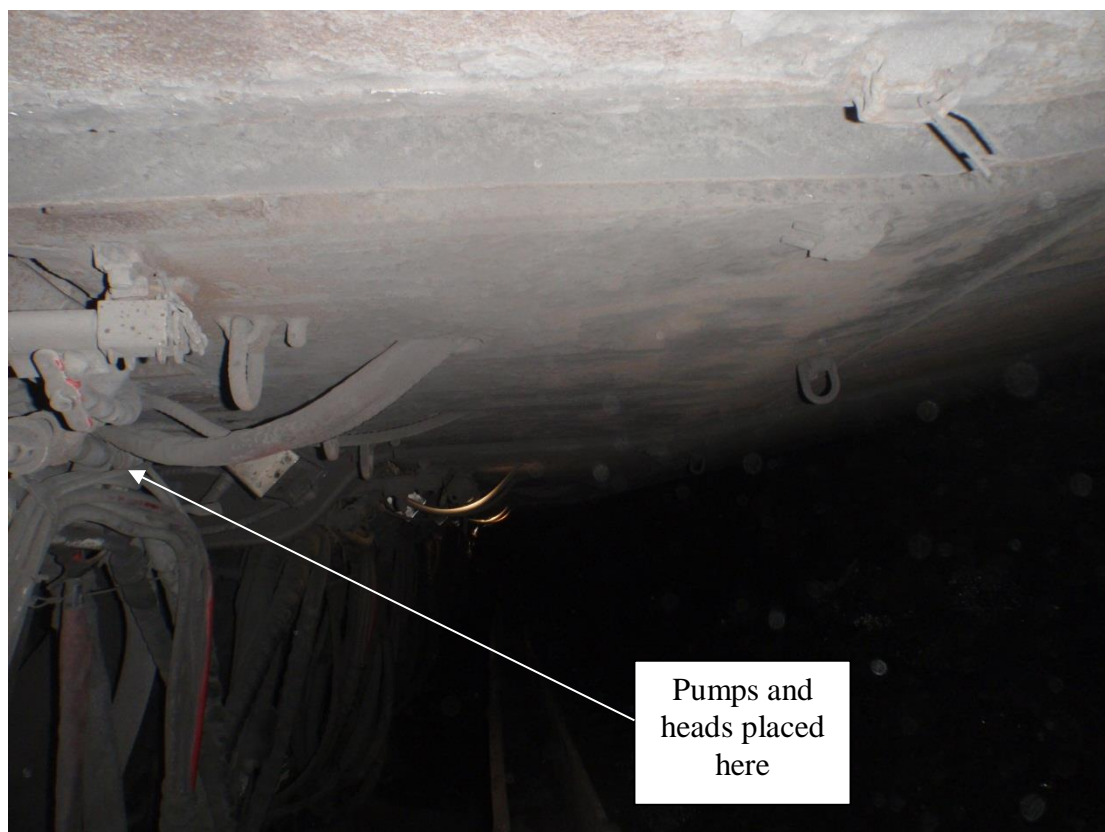
**Figure 7.48 Mine C Pump and Head Location for Crusher Dust on Chock #5**

### **7.3.2.5 Pump and Head Location for Total Dust**

Sampling the total dust loads produced was obtained by placing monitors on the tailgate chock. These monitors will sample the full dust loads generated from all sources on the longwall. Figure 7.49 shows the location of the pumps and heads to sample total face dust.

## CHAPTER SEVEN

### Field Trials In Australian Longwalls



**Figure 7.49 Mine C Placement of Pumps and Heads on Tailgate Chocks**

### 7.3.3 Mine C Installed Engineering Controls

Table 7.7 details the installed engineering controls on Mine C longwall.

**Table 7.7 Mine C Installed Engineering Controls**

<b>BSL discharge</b>	
Number of sprays in BSL discharge	3
Type: Solid, Hollow cone, Flat, V	V-Spray
Spray Diameter	4mm
Water Pressure	1200kPa
Water Flow	45lpm
<b>BSL Sprays</b>	
Number of sprays	3
Type: Solid, Hollow cone, Flat, V	V-Spray
Spray Diameter	4mm
Water Pressure	1200kPa
Water Flow	45lpm
<b>BSL crusher</b>	
Number of sprays	9
Type: Solid, Hollow cone, Flat, V	V-Spray



## CHAPTER SEVEN

### Field Trials In Australian Longwalls

Spray Diameter	4mm
Water Pressure	1200kPa
Water Flow	45lpm
<b>Shearer</b>	
Number of sprays	48
Type: Solid, Hollow cone, Flat, V	Hollow Cone
Spray Diameter	1.5mm
Water Pressure	NA
Water Flow	90lpm
Types of Picks	NA
<b>Shearer Clearer</b>	
Number of sprays	6
Type: Solid, Hollow cone, Flat, V	Solid Cone
Spray Diameter	3mm
Water Pressure	20Bar
Water Flow	25lpm
<b>Chock Sprays</b>	
Number of sprays	2 per chock
Type: Solid, Hollow cone, Flat, V	Hollow Cone
Spray Diameter	2mm
Water Pressure	NA
Water Flow	NA
<b>Other Dust Controls Used?</b>	
Shearer drum speed	31rpm
Shearer Speed	10m/min
Av. Shears per Shift	4
Av. Tonnes per Shear	1250

#### 7.3.3.1 Installed Controls in the BSL Discharge

The BSL discharge has the traditional FRAS rubber skirting arrangement between the bottoms of the discharge for the coal discharge onto the outbye belt. Inside the discharge hood is three 6mm V sprays.

#### 7.3.3.2 Installed Controls in the Crusher and BSL

The Mine C crusher and BSL are fully enclosed, have conveyor belting at the crusher intake, two strips before the crusher and skirts on the BSL discharge to the outbye belt.

## CHAPTER SEVEN

### Field Trials In Australian Longwalls

---

#### 7.3.3.3 BSL Scrubber

Mine C has a hydraulic drive dust extractor fitted to the BSL discharge. Figure 7.50 shows the installed BSL scrubber.

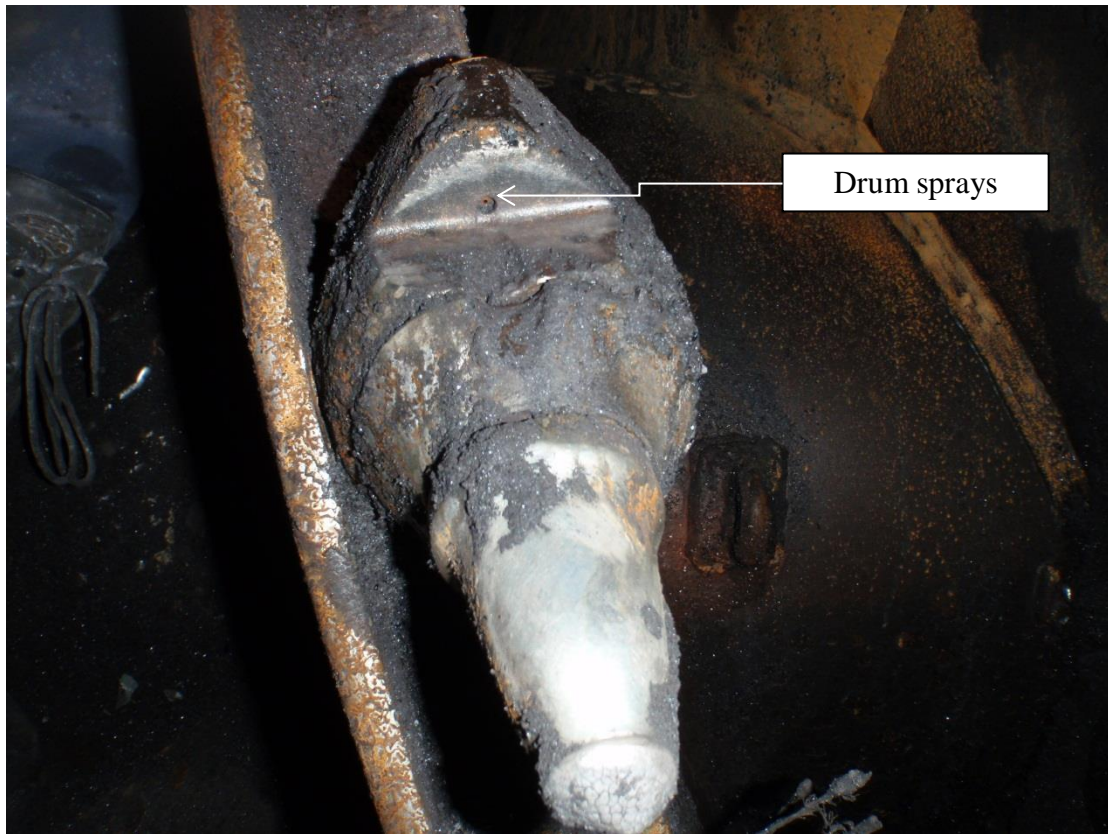


**Figure 7.50 Mine C Installed BSL Scrubber**

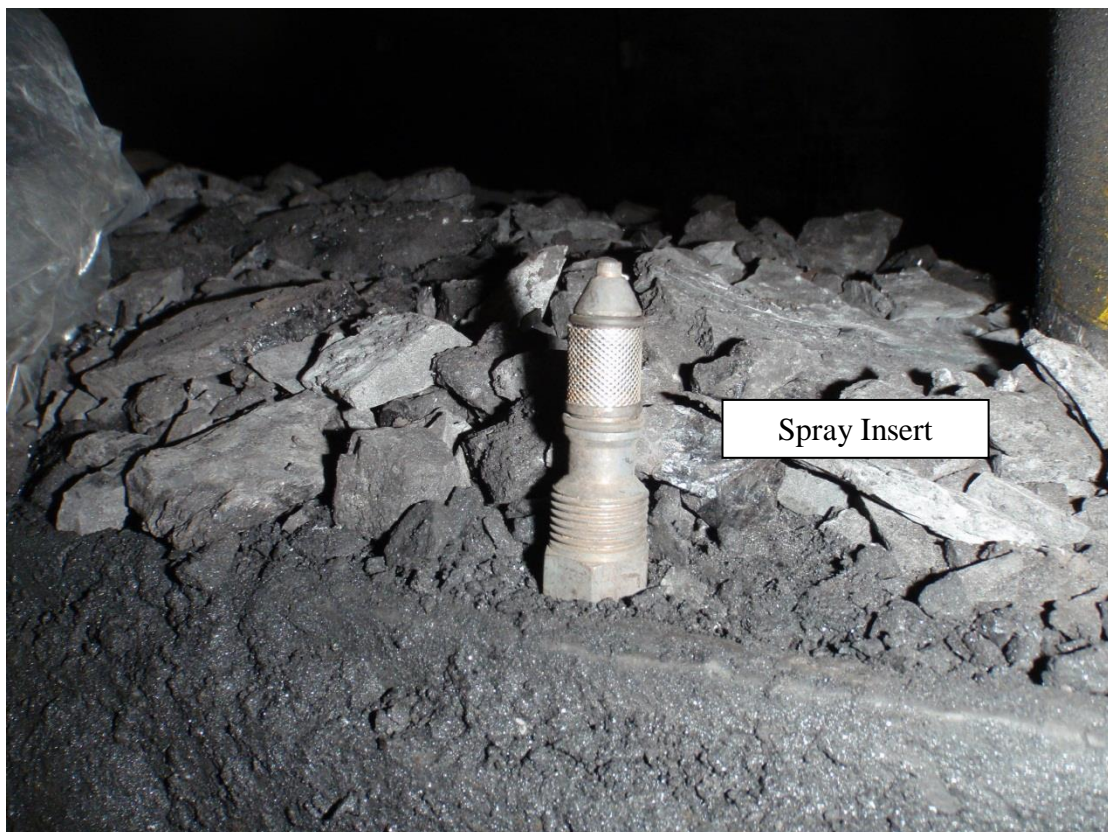
#### 7.3.3.4 Shearer Dust Controls

Drum mounted water sprays are the first point dust suppression process on the shearer cutting drum. The sprays are pointed directly at the pick point of coal fracture and add moisture to minimize dust liberation. Optimum pressure to the sprays is usually 20-30 Bar, the sprays are full cone spray pattern and there are 84 sprays on the drum.

Figures 7.51 shows the location of the spray behind the pick and Figure 7.52 shows the spray insert used.



**Figure 7.51 Mine C Installed Drum Sprays behind Pick**



**Figure 7.52 Mine C Drum Spray Insert**

## CHAPTER SEVEN

### Field Trials In Australian Longwalls

---

#### 7.3.3.5 Other Dust Controls

Mine C has 2 chock sprays installed on every chock that are sequenced to come on as the shearer passes. They are positioned so as to stop face dust from rolling out into the walkway. The sprays are a hollow cone spray, 1.2mm orifice, use 100 lpm of water at 60 Bar of pressure. The installed chock sprays were not working during the testing.

#### 7.4 Field Study Mine D

Mine D was the fourth mine to undertake the field study with the data being collected by the author. Pump and head placement along with data collection was as per the collection process detailed in Chapter 6. Filter preparation for this testing was performed as detailed in section 6.3. This raw data was analysed utilising the Dust Mitigation Efficiency formula detailed in section 6.3.7.

##### 7.4.1 Operational Parameters of Mine D

Table 7.8 details the operating parameters of Mine D.

**Table 7.8 Mine D Operating Parameters**

	<b>Mine D</b>
<b>State/Coalfield</b>	Queensland/Northern
<b>Seam/Working thickness, metres (m)</b>	Goonyella Middle/ 3.8-4.5m
<b>Coal Type</b>	Coking
<b>Depth of cover, metres (m)</b>	110-320m
<b>Marketable reserves, proved and probable, million tonnes (Mt)</b>	132Mt
<b>Longwall operations (weekly)</b>	2 x 12hr shifts, 5 days; 9 unit shifts
<b>Other operations (weekly)</b>	2 x 12hr shifts, 5 days; 18 unit shifts
<b>Raw coal output 2011, tonnes</b>	
Longwall face, tonnes	3,172,100
Other, tonnes	161,400
Total, tonnes	3,333,500

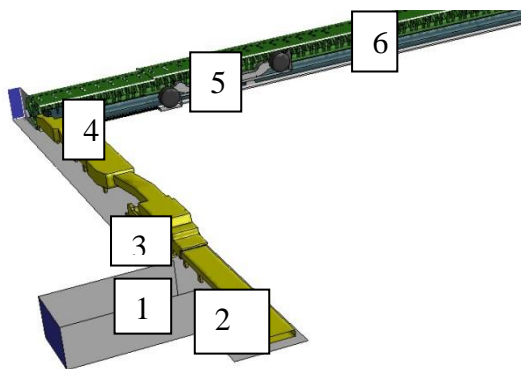
## CHAPTER SEVEN

### Field Trials In Australian Longwalls

Forecast total raw coal output 2012, tonnes	5,500,000
Longwall face raw coal output 2010-11, tonnes	4,963,364
Total mine raw coal output 2010-11, tonnes	5,175,495
<b>Commenced longwall mining</b>	Feb-99
<b>Longwall block dimensions 2011</b>	
Width, metres (m)	300m
Length, metres (m)	2500m
<b>Shearer manufacturer</b>	Joy
Type	6LS - 5, DERDS, 2 x 7LS - 6, DERDS
Drum diameter, metres (m)	M/G 2.5m, T/G 2.5m
<b>Cutting height, metres (m)/ Method/ Web depth, millimetres (mm)</b>	4.1-4.5m, Uni-di, 850mm
<b>Install power, kilowatts (kW)</b>	1580kW
<b>Roof support manufacturer</b>	Joy
Type/Number of supports	2-leg chock chock, 25, 149, 2-leg chock chock, 151
Yield load, tonnes (t) Working range, metres (m) Control	1200t, 980t, 3m-4.8m, RS20, 1750t, 2.4m-5m, RS20-S
<b>Face conveyor manufacturer</b>	Joy
Width, millimetres (mm) Chain size, millimetres (mm)	1100mm / 2050mm, 48mm twin-in-board /48mm twin-in-board
Chain speed metres per second (m/s) Manufacturer	1.67m/s, Parsons
Motors, kilowatts (kW)	3 x 800kW, 3 x 1000kW
<b>Beam stage loader manufacturer kilowatts (kW)</b>	Joy, 400kW
<b>Coal crusher manufacturer, kilowatts (kW)</b>	Joy (high impact), 400kW
<b>Coal clearance (to surface) type, Capacity, tonnes per hour (tph)</b>	Conveyor 5500tph
<b>Ventilation on Longwall</b>	65m <sup>3</sup> /sec

#### 7.4.2 Pump and Head Location Mine D

Figure 7.53 shows pump and head placement for data collection at Mine D.



Monitor	Position
1	LOC
2	Belt Road
3	BSL Discharge
4	Maingate
5	Midface
6	Tailgate

Figure 7.53 Mine D Pump and Head Location

## **CHAPTER SEVEN**

### Field Trials In Australian Longwalls

---

#### **7.4.2.1 Pump and Head Location in Last Open Cut-through**

The monitors and gravimetric heads were placed in the last open cut-through before the ventilation enters the longwall to measure dust entering the longwall from outbye travel roads.

#### **7.4.2.2 Pump and Head Location in Belt Road**

The monitors and gravimetric heads were placed in the belt road to measure fugitive dust entering the longwall from the conveyor belt.

#### **7.4.2.3 Pump and Head Location at BSL Discharge**

Sampling monitors and heads were placed inbye from the BSL discharge to the outbye belt and hung from installed mesh.

The heads were changed after the first sampling period of two shears had been completed.

#### **7.4.2.4 Pump and Head Location for Crusher**

Pumps and heads were placed on chock #2 to sample crusher generated dust that may escape from the crusher mouth into the intake ventilation at the maingate. The pumps and heads were mounted on hosing the control box.

#### **7.4.2.5 Pump and Head Location for Total Dust**

Sampling the total dust loads produced was obtained by placing monitors on the tailgate chock, or chock 139. These monitors will sample the full dust loads generated from all sources on the longwall.

## CHAPTER SEVEN

### Field Trials In Australian Longwalls

---

#### 7.4.3 Mine D Installed Engineering Controls

Table 7.9 details the installed engineering controls on Mine D longwall.

**Table 7.9 Mine D Installed Engineering Controls**

<b>BSL discharge</b>	
Number of sprays in BSL discharge	3
Type: Solid, Hollow cone, Flat, V	V-Spray
Spray Diameter	4mm
Water Pressure	1200kPa
Water Flow	45lpm
<b>BSL Sprays</b>	
Number of sprays	3
Type: Solid, Hollow cone, Flat, V	V-Spray
Spray Diameter	4mm
Water Pressure	1200kPa
Water Flow	45lpm
<b>BSL crusher</b>	
Number of sprays	9
Type: Solid, Hollow cone, Flat, V	V-Spray
Spray Diameter	4mm
Water Pressure	1200kPa
Water Flow	45lpm
<b>Shearer</b>	
Number of sprays	48
Type: Solid, Hollow cone, Flat, V	Hollow Cone
Spray Diameter	1.5mm
Water Pressure	NA
Water Flow	90lpm
Types of Picks	NA
<b>Shearer Clearer</b>	
Number of sprays	6
Type: Solid, Hollow cone, Flat, V	Solid Cone
Spray Diameter	3mm
Water Pressure	20Bar
Water Flow	25lpm
<b>Chock Sprays</b>	
Number of sprays	2 per chock
Type: Solid, Hollow cone, Flat, V	Hollow Cone
Spray Diameter	2mm
Water Pressure	NA

## CHAPTER SEVEN

### Field Trials In Australian Longwalls

Water Flow	NA
<b>Other Dust Controls Used?</b>	None
Shearer drum speed	31rpm
Shearer Speed	10m/min
Av. Shears per Shift	4
Av. Tonnes per Shear	1250

#### 7.4.3.1 Installed Controls in the BSL Discharge

The BSL discharge has the traditional FRAS rubber skirting arrangement between the bottom of the discharge for the coal discharge onto the outbye belt. Inside the discharge hood is three 6mm solid cone sprays.

#### 7.4.3.2 Installed Controls in the Crusher and BSL

The Mine D crusher and BSL are fully enclosed, have conveyor belting at the crusher intake, two strips before the crusher and skirts on the BSL discharge to the outbye belt.

#### 7.4.3.3 BSL Scrubber

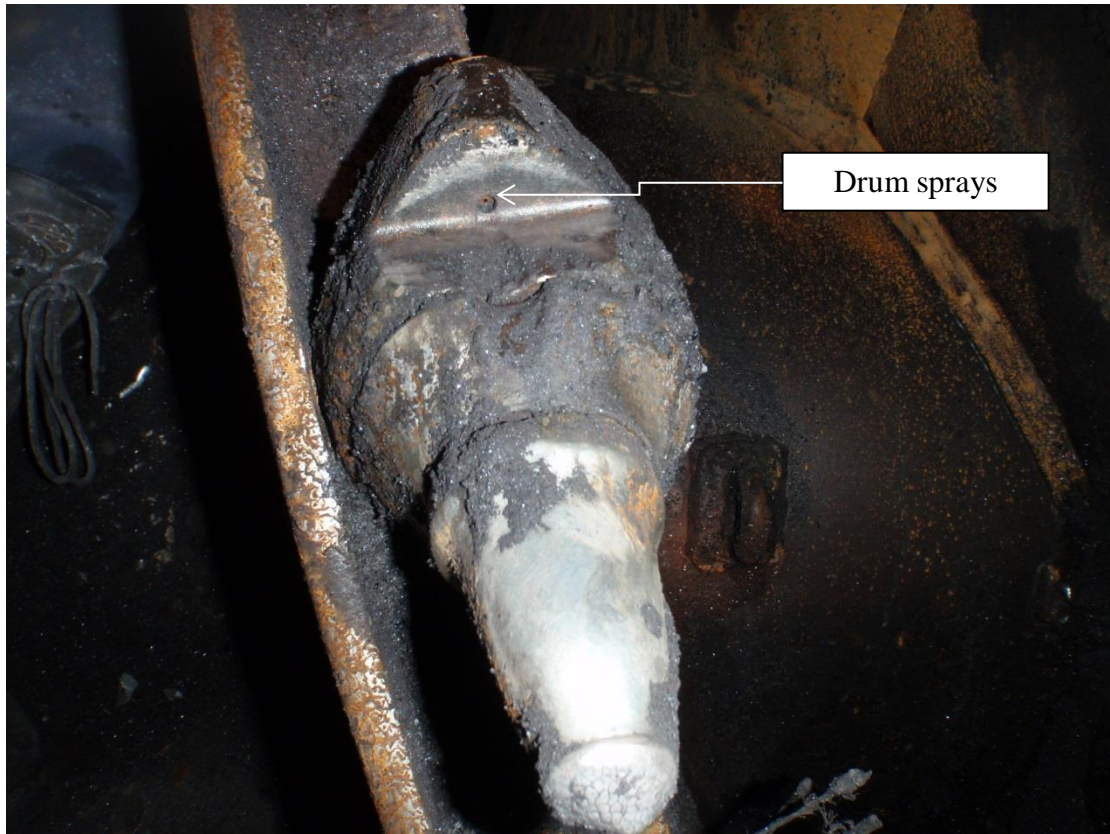
Mine D has an electric drive dust extractor fitted to the BSL drawing from the crusher and the discharge.

#### 7.4.3.4 Shearer Dust Controls

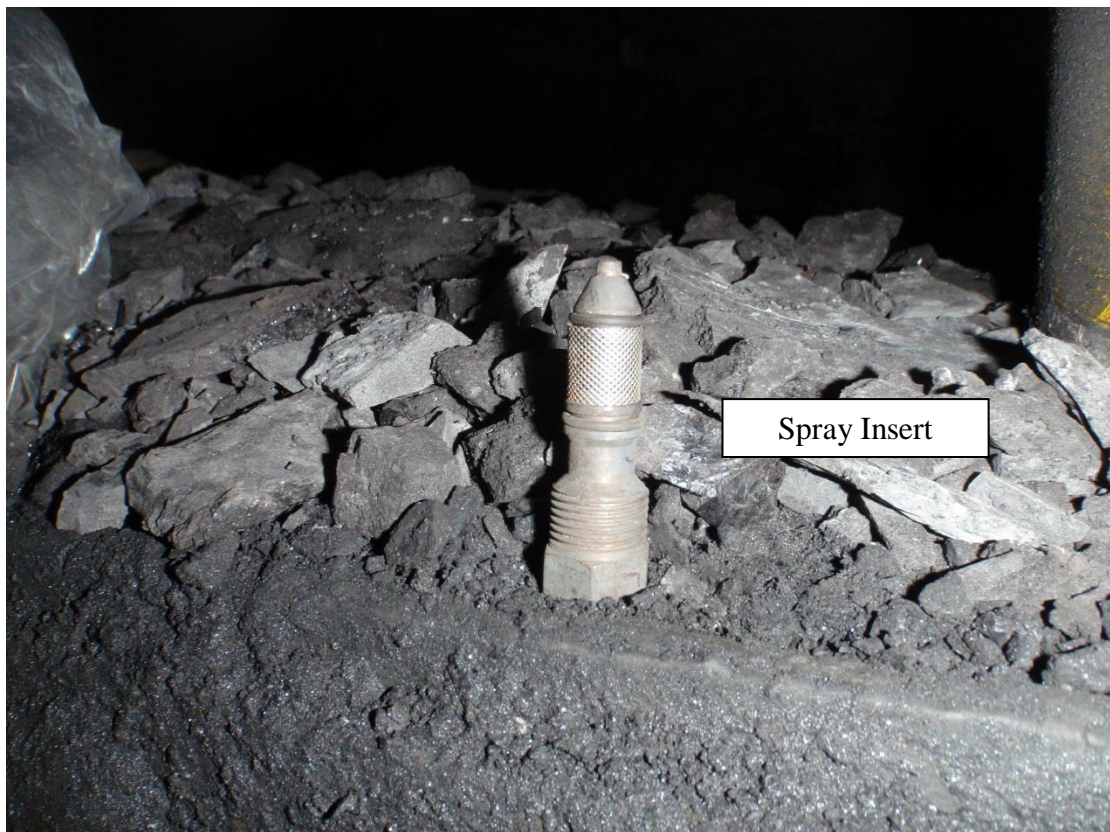
Drum mounted water sprays are the first point dust suppression process on the shearer cutting drum. The sprays are pointed directly at the pick point of coal fracture and add moisture to minimize dust liberation. Optimum pressure to the sprays is usually 20-30 Bar, the sprays are full cone spray pattern and there are 84 sprays on the drum.

Figure 7.54 shows the location of the spray behind the pick and Figure 7.55 shows the spray insert used.





**Figure 7.54 Mine D Installed Drum Sprays behind Pick**



**Figure 7.55 Mine D Drum Spray Insert**

## CHAPTER SEVEN

### Field Trials In Australian Longwalls

---

#### 7.4.3.5 Other Dust Controls

Mine D has 2 chock sprays installed on every chock that are sequenced to come on as the shearer passes. They are positioned so as to stop face dust from rolling out into the walkway. The sprays are a hollow cone spray, 1.2mm orifice, use 100 lpm of water at 60 Bar of pressure. These were not operating whilst testing was being performed.

#### 7.5 Field Study Mine E

Mine E was the fifth mine to undertake the field study with the data being collected by the author. Multiple samples were taken at Mine E. Pump and head placement along with data collection was as per the collection process detailed in Chapter 6. Filter preparation for this testing was performed as detailed in section 6.3. This raw data was analysed utilising the Dust Mitigation Efficiency formula detailed in section 6.3.7.

##### 7.5.1 Operational Parameters of Mine E

Table 7.10 details the operating parameters of Mine E.

**Table 7.10 Mine E Operating Parameters**

	<b>Mine E</b>
<b>State/Coalfield</b>	New South Wales Newcastle
<b>Seam/Working thickness, metres (m)</b>	Greta 5-6.5m 2.9m Shearer Extraction Top Coal Caving Remaining Seam Section
<b>Coal Type</b>	Coking
<b>Depth of cover, metres (m)</b>	530m
<b>Marketable reserves, proved and probable, million tonnes (Mt)</b>	34.2Mt
<b>Longwall operations (weekly)</b>	3 x 10hr, Mon-Thurs 10 production shifts, 2 x Maint shifts
<b>Other operations (weekly)</b>	3 x 10hr, Mon-Thurs 2 x 12hr Fri-Sun
	16 Production Shifts + 2 x Maint shifts
<b>Raw coal output 2011, tonnes</b>	
Longwall face, tonnes	1,658,800
Other, tonnes	239,400

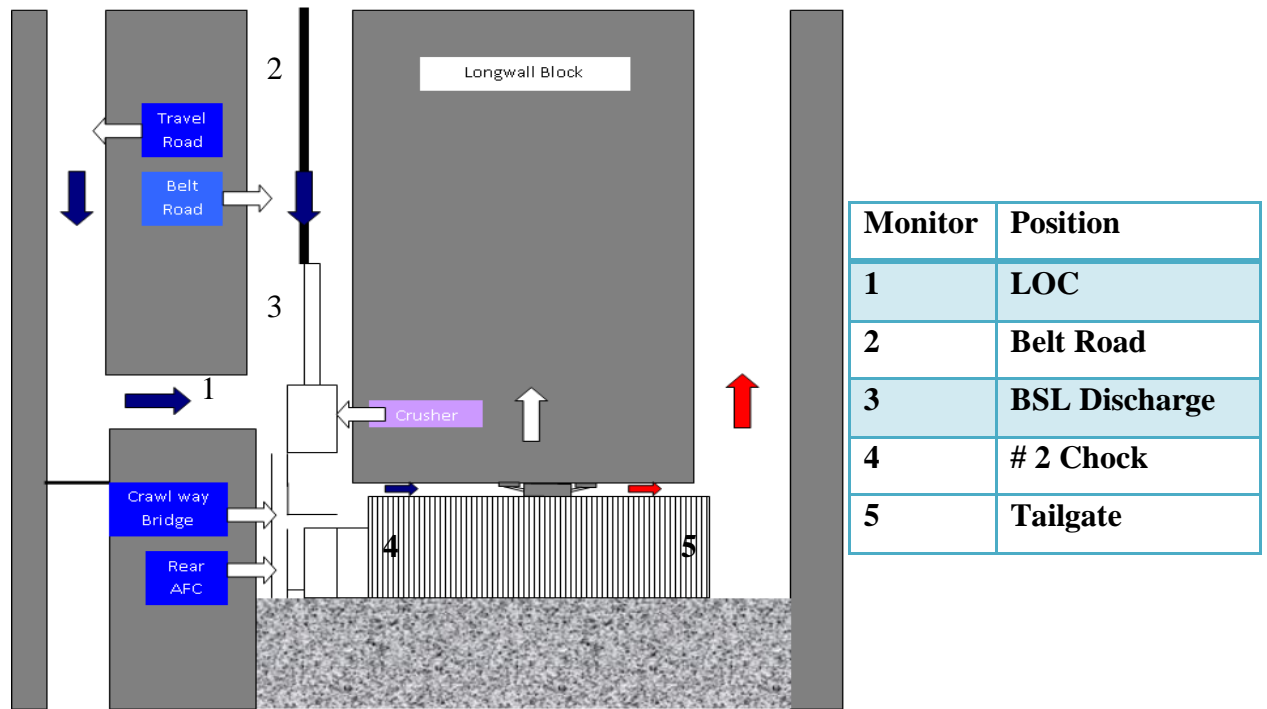
## CHAPTER SEVEN

### Field Trials In Australian Longwalls

Total, tonnes	1,898,200
Forecast total raw coal output 2012, tonnes	1,707,000
Longwall face raw coal output 2010-11, tonnes	1,621,000
Total mine raw coal output 2010-11, tonnes	1,847,000
<b>Commenced longwall mining</b>	LTCC September 2006
<b>Longwall block dimensions 2011</b>	
Width, metres (m)	227m
Length, metres (m)	962m
<b>Shearer manufacturer</b>	Bucyrus
Type	Electra EL 2000 DERDS
Drum diameter, metres (m)	M/G 2.2m, T/G 2.2m
<b>Cutting height, metres (m)/ Method/ Web depth, millimetres (mm)</b>	2.9m Bi-di 1000mm
<b>Install power, kilowatts (kW)</b>	1494kW
<b>Roof support manufacturer</b>	Bucyrus
Type/Number of supports	LTCC 2-leg chock 131
Yield load, tonnes (t) Working range, metres (m) Control	1040t 1.9-3.5m Bucyrus PMC-R
<b>Face conveyor manufacturer</b>	Bucyrus
Width, millimetres (mm) Chain size, millimetres (mm)	Face PF6 1142mm Rear PF5 1142mm
Chain speed metres per second (m/s) Manufacturer	42mm twin-in-board THIELE
Motors, kilowatts (kW)	Face AFC & Rear AFC 2 x 540kW
<b>Beam stage loader manufacturer kilowatts (kW)</b>	Bucyrus 400kW
<b>Coal crusher manufacturer, kilowatts (kW)</b>	Bucyrus 400kW
<b>Coal clearance (to surface) type, Capacity, tonnes per hour (tph)</b>	Conveyor 1000tph
<b>Ventilation on Longwall</b>	35m <sup>3</sup> /sec

### 7.5.2 Pump and Head Location Mine E

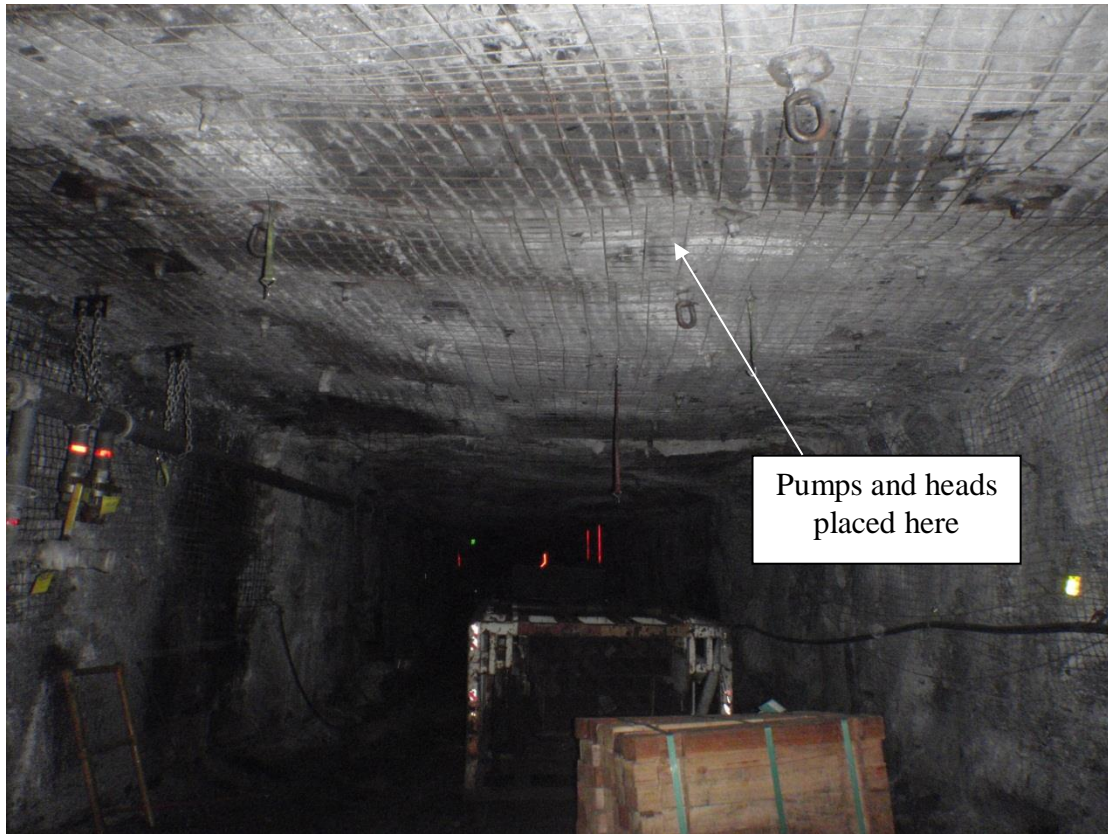
Monitors and heads were placed on each independent source of dust generation, namely the last open cut-through, the belt road, inbye of the BSL discharge, chock #5 and the tailgate. In each location, two monitors and two heads were placed to sample both respirable and inhalable dust loads. Figure 7.56 shows the location of pumps and heads for the testing.



**Figure 7.56 Mine E Pump and Head Location**

### 7.5.2.1 Pump and Head Location in Last Open Cut-through

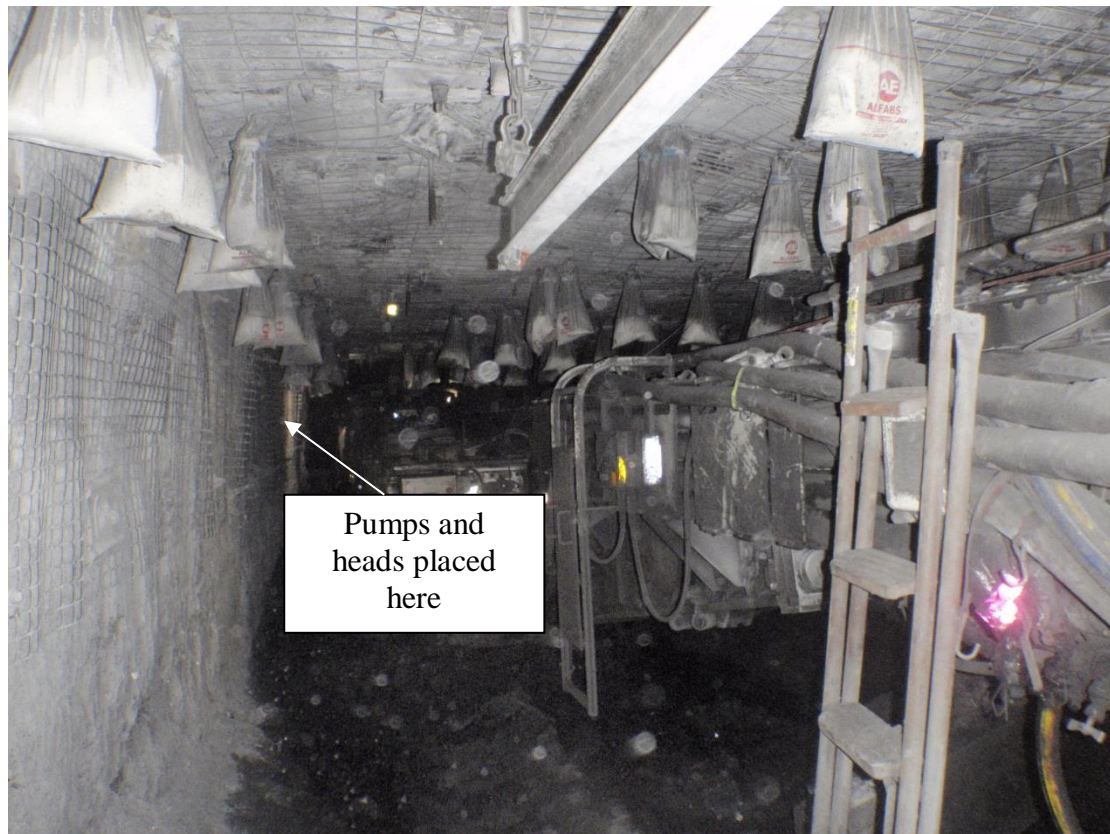
The monitors and gravimetric heads were placed in the last open cut-through before the ventilation enters the longwall to measure dust entering the longwall from outbye travel roads. Figure 7.57 denotes the positioning of pumps and heads in the last open cut-through.



**Figure 7.57 Mine E Pump and Head Location in LOC**

### **7.5.2.2 Pump and Head Location in Belt Road**

The monitors and gravimetric heads were placed in the belt road to measure fugitive dust entering the longwall from the conveyor belt. Figure 7.58 shows the positioning of pumps and heads in the belt road.



**Figure 7.58 Mine E Pump and Head Location in the Belt Road**

### **7.5.2.3 Pump and Head Location at BSL Discharge**

Sampling monitors and heads were placed inbye from the BSL discharge to the outbye belt and hung from maingate travelling chock.

The heads were changed after the first sampling period of two shears had been completed. Figure 7.59 shows BSL discharge pump and head placement for sampling.

## CHAPTER SEVEN

### Field Trials In Australian Longwalls

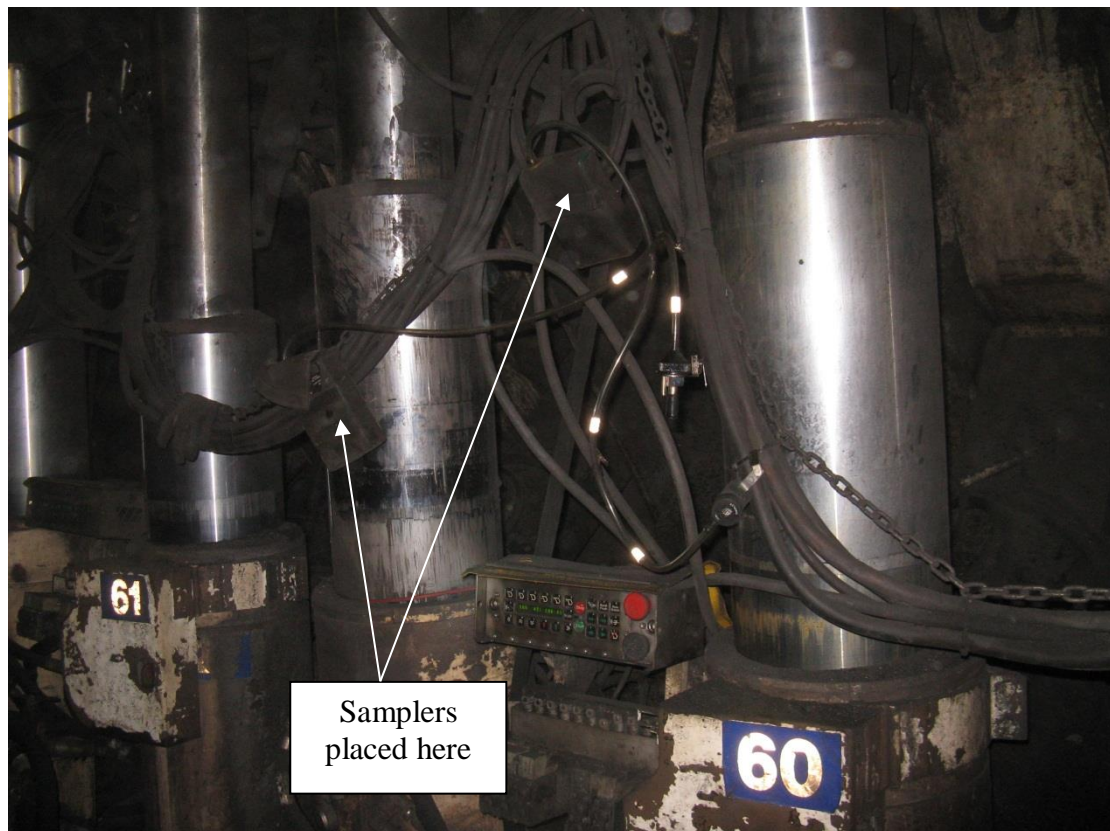
---



**Figure 7.59 Mine E Pump and Head Location for BSL Discharge**

#### **7.5.2.4 Pump and Head Location for Crusher Dust**

Pumps and heads were placed on chock #2 to sample crusher generated dust that may escape from the crusher mouth into the intake ventilation at the maingate. The pumps and heads were mounted on hosing on the control box. Figure 7.60 shows pump and head positioning on chock #2 to sample fugitive crusher dust.



**Figure 7.60 Mine E Pump and Head Location for Crusher Dust on Chock**

#### **7.5.2.5 Pump and Head Location for Total Dust**

Sampling the total dust loads produced was obtained by placing monitors on the tailgate chock, or chock 131. These monitors will sample the full dust loads generated from all sources on the longwall. Figure 7.61 shows the location of the pumps and heads to sample total face dust.



## CHAPTER SEVEN

### Field Trials In Australian Longwalls

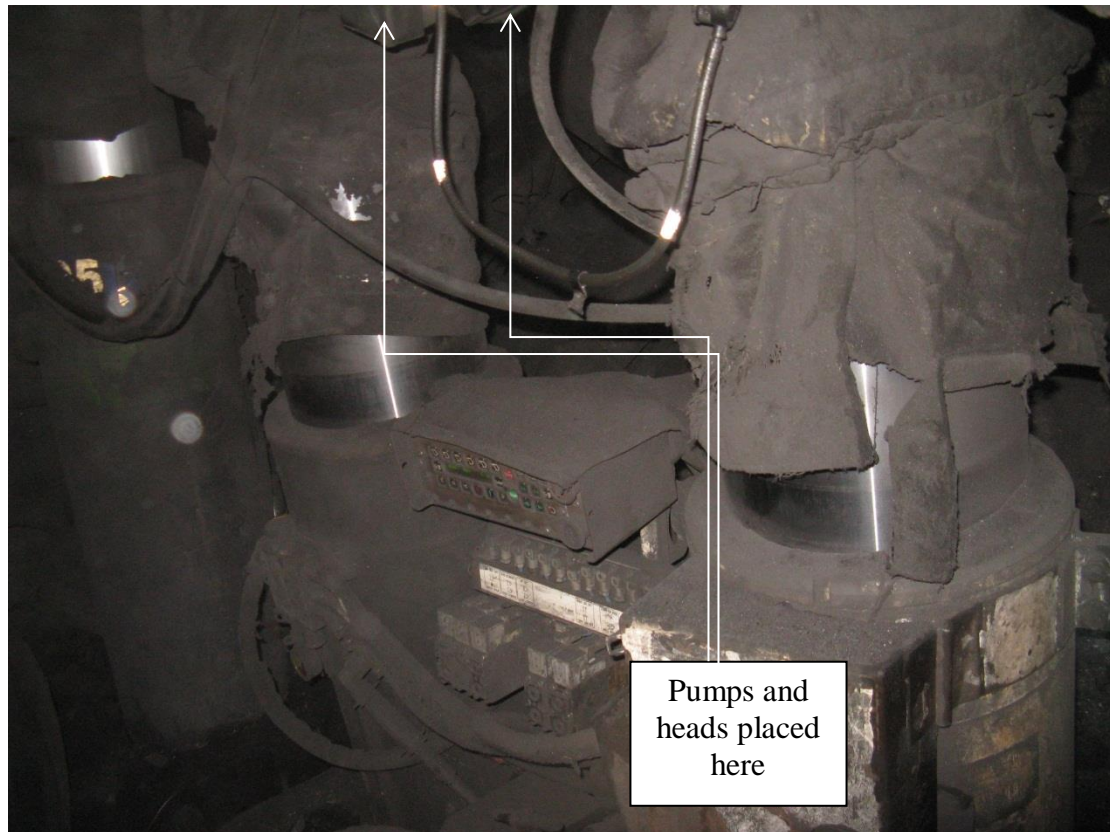


Figure 7.61 Mine E Pump and Head Location in the Tailgate

### 7.5.3 Mine E Installed Engineering Controls

Table 7.11 details the installed engineering controls on Mine E longwall.

Table 7.11 Mine E Installed Engineering Controls

<b>BSL discharge</b>	
Number of sprays in BSL discharge	2
Type: Solid, Hollow cone, Flat, V	Hollow Cone
Spray Diameter	2mm
Water Pressure	20Bar
Water Flow	NA
<b>BSL Sprays</b>	
Number of sprays	3
Type: Solid, Hollow cone, Flat, V	Hollow Cone
Spray Diameter	2mm
Water Pressure	20Bar
Water Flow	NA
<b>BSL crusher</b>	
Number of sprays	9
Type: Solid, Hollow cone, Flat, V	Hollow Cone

## CHAPTER SEVEN

### Field Trials In Australian Longwalls

Spray Diameter	6mm
Water Pressure	20Bar
Sprays on Crusher Intake	3 x hollow cone, 2mm, 20 Bar over chain
<b>Shearer</b>	
Number of sprays	64
Type: Solid, Hollow cone, Flat, V	Solid Cone
Spray Diameter	1.2mm
Water Pressure	65Bar
Water Flow	475lpm
Types of Picks	Radial
<b>Shearer Clearer</b>	None
<b>Chock Sprays</b>	
Number of sprays	2 per chock
Type: Solid, Hollow cone, Flat, V	Hollow Cone
Spray Diameter	1.2mm
Water Pressure	60Bar
Water Flow	100lpm
<b>Other Dust Controls Used?</b>	Sprays on crusher intake
Shearer drum speed	30rpm
Shearer Speed	5-8m/minute
Av. Shears per Shift	6
Av. Tonnes per Shear	1200

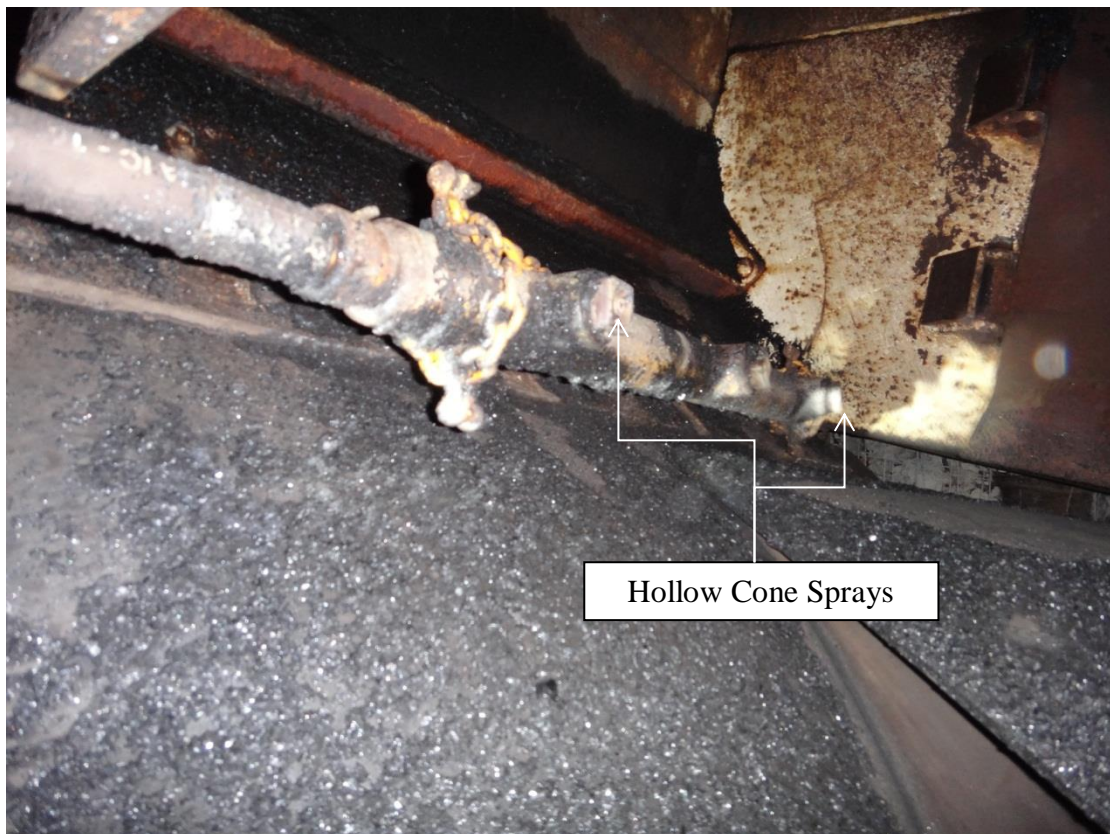
#### 7.5.3.1 Installed Controls in the BSL Discharge

The BSL discharge has the traditional FRAS rubber skirting arrangement between the bottoms of the discharge for the coal discharge onto the outbye belt. Inside the discharge hood is two 6mm hollow cone sprays.

Figure 7.62 shows the FRAS rubber skirting from the BSL discharge to the outbye belt and Figure 7.63 shows the hollow cone sprays located inside the discharge hood.



**Figure 7.62 Mine E BSL Discharge Skirting**



**Figure 7.63 Mine E Hollow Cone Sprays inside Discharge Hood**

### 7.5.3.2 Installed Controls in the Crusher and BSL

The Mine E crusher and BSL are fully enclosed but utilise a spray system to control dust generated from the crusher and from the front and rear conveyors. Sprays installed are a combination of hollow cone sprays and flat sprays designed to encapsulate and knockdown the dust. Figure 7.64 shows the spray location on the entry to the crusher from the front conveyor.



**Figure 7.64 Mine E Crusher Intake Sprays**

Mine E has also installed a hollow cone spray arrangement on the transfer from the rear AFC to the crusher intake. Figure 7.65 shows the spray arrangement on the transfer from the rear AFC to the BSL chain.

## CHAPTER SEVEN

### Field Trials In Australian Longwalls

---



**Figure 7.65 Mine E Sprays on Rear AFC**

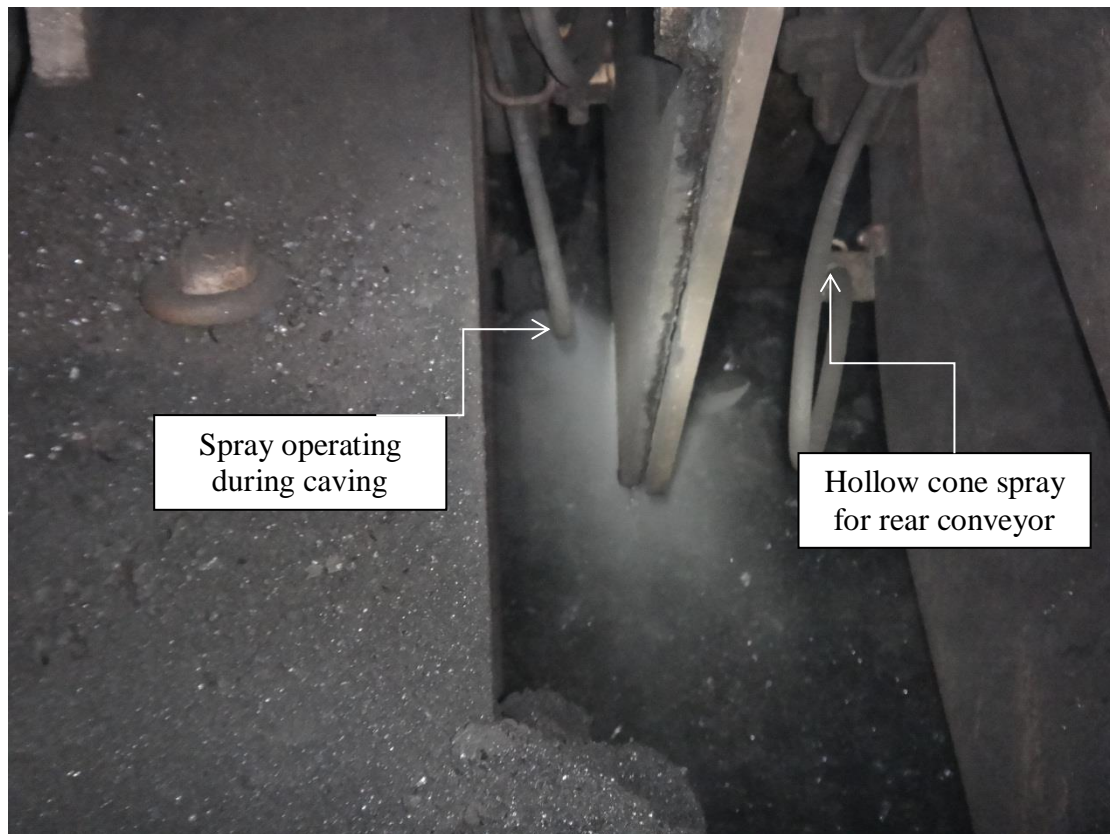
#### **7.5.3.3 Rear AFC Sprays**

Mine E has sprays installed on the rear AFC to mitigate dust entering the walkway during caving. The installed sprays are a solid cone spray with a 2mm orifice. The sprays are located at the rear of each chock, 2 per chock. Sprays are activated when the rear canopy is operated for caving. Figure 7.66 shows the rear caving spray location on the chocks and the adjacent spray operating during caving.

## CHAPTER SEVEN

### Field Trials In Australian Longwalls

---

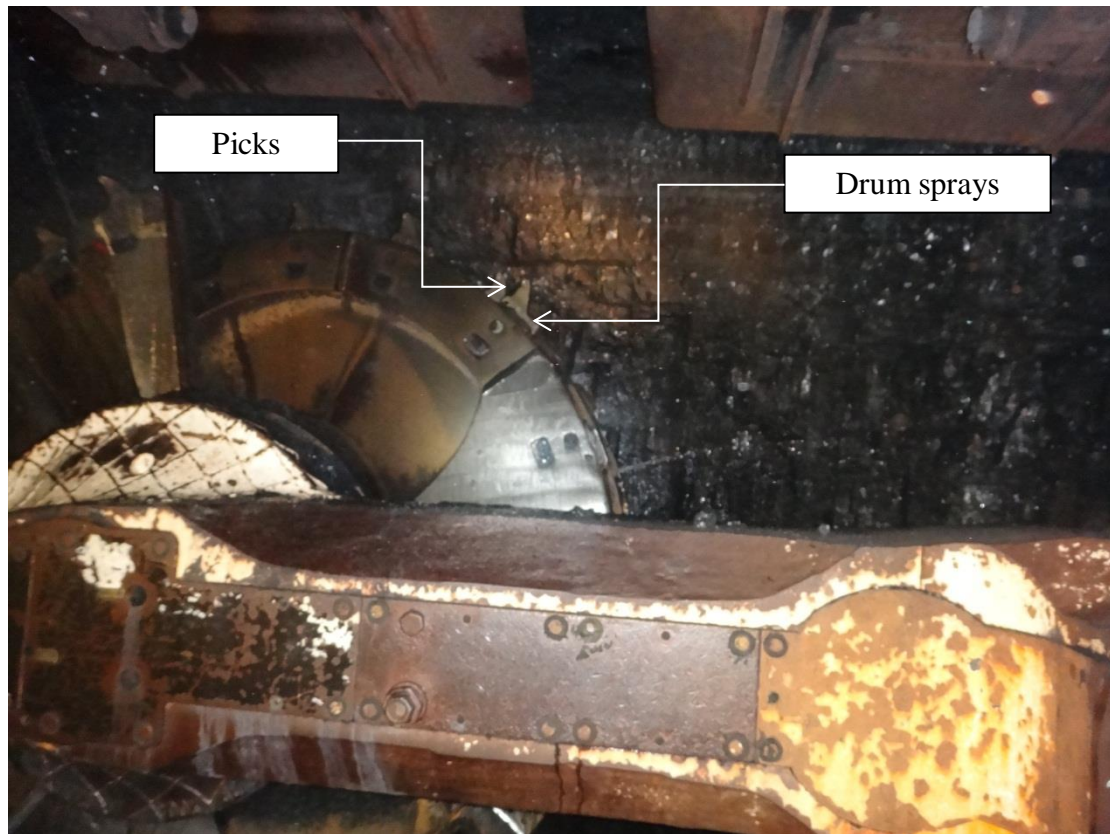


**Figure 7.66 Mine E Rear Caving Sprays**

#### **7.5.3.4 Shearer Dust Controls**

Drum mounted water sprays are the first point dust suppression process on the shearer cutting drum. The sprays are pointed directly at the pick point of coal fracture and add moisture to minimize dust liberation. Optimum pressure to the sprays is usually 20-30 Bar, the sprays are full cone spray pattern and there are 84 sprays on the drum.

Figure 7.67 shows the location of the spray behind the pick.



**Figure 7.67 Mine E Installed Drum Sprays and Pick**

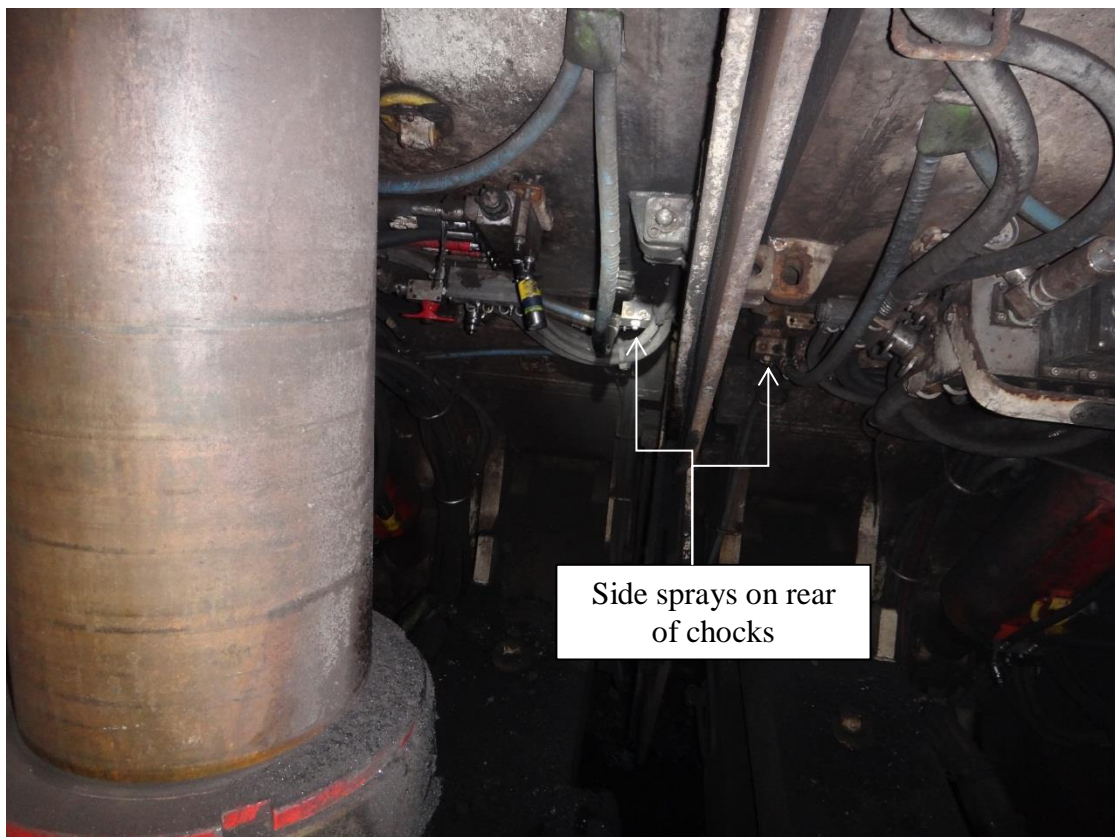
### **7.5.3.5 Other Dust Controls**

Mine E has 2 chock sprays installed on every chock that are sequenced to come on as the shearer passes. They are positioned so as to stop face dust from rolling out into the walkway. The sprays are a hollow cone spray, 1.2mm orifice, use 100 lpm of water at 60 Bar of pressure. Figure 7.68 shows the installed chock sprays operating.

Mine E has also installed sprays at the side of each canopy to control dust generated during chock movement. These sprays are sequenced to activate when the chock depressurises. Figure 7.69 shows positioning of sprays on the sides of each chock to mitigate dust generated during chock movement.



**Figure 7.68 Mine E Installed Chock Sprays**



**Figure 7.69 Mine E Side Chock Sprays**



#### 7.6 Summary

Engineering controls installed for respirable and inhalable dust mitigation on longwalls involved in this thesis were all installed by the OEM supplier of the longwall. Discussions with management, maintenance personnel and operators at each of these longwall mines indicate that the engineering controls are installed with little or no scientific explanation or basis from the OEM or involvement from the mine themselves. Collected data indicates that all OEM's supply a similar configuration with regard to spray types and spray placement in the BSL discharge, the crusher, the maingate, on the shearer and on the chocks. Sprays have a similar orifice size, similar pressure and flow feeds and similar positioning.

Changes, variations and additions to the standard OEM supply were installed by the mine maintenance personnel. These changes, variations or additions were undertaken based on the experience of the mine in dust mitigation and not on scientific grounds. Discussions relating to implemented changes indicate that the changes were based on subjective evaluations of mitigation performance and were not quantified.

**CHAPTER EIGHT - DATA ANALYSIS AND DISCUSSION**

**8.1 Introduction**

A total of 360 samples were taken for data analysis to quantify the robustness of the new testing methodology. Of these, 190 were respirable fraction samples and the remaining 170 were inhalable size fractions. Tests 1 and 2 utilised the greatest amount of both respirable and inhalable samples collected with fewer pumps and heads used for data collection as testing progressed. The reason for this is that it was found that the tailgate dust collected represented the total respirable and inhalable dust produced on the longwall and was the most reliable indicator of control efficiency without the need for further data collection on the chocks. The outbye pumps and heads provided accurate data on installed control efficiencies, and coupled with the maingate data, all provided an accurate signature of the tested longwall. Table 8.1 details the number of respirable and inhalable samples collected at each of the mines tested.

**Table 8.1 Respirable and Inhalable Data Collected**

<b>Test #</b>	<b>Mine</b>	<b>Respirable Samples</b>	<b>Inhalable Samples</b>
Test 1	Mine A	26	22
Test 2	Mine B	20	20
Test 3	Mine C	16	0
Test 4	Mine C	12	12
Test 5	Mine C	12	12
Test 6	Mine B	12	12
Test 7	Mine B	8	8
Test 8	Mine D	12	12
Test 9	Mine D	12	12
Test 10	Mine B	8	8
Test 11	Mine B	12	12
Test 12	Mine E	10	10
Test 13	Mine C	10	10
Test 14	Mine C	10	10
Test 15	Mine E	10	10
	<b>Sub Total</b>	<b>190</b>	<b>170</b>
	<b>Total</b>		<b>360</b>

The results analysed in this chapter will be in the same order as detailed above.

## 8.2 Results Mine A Test 1

Mine A was the first mine sampled using the DME Model. Only 1 set of samples were taken at this mine and these were collected by Coal Services under the direction of the author. Coal Services also prepared the filters as per AS2985 with post weighing being performed under this guideline as well. Analysis and calculations were performed by the author as described in 6.3.7.

### 8.2.1 Respirable and Inhalable Dust Raw Data

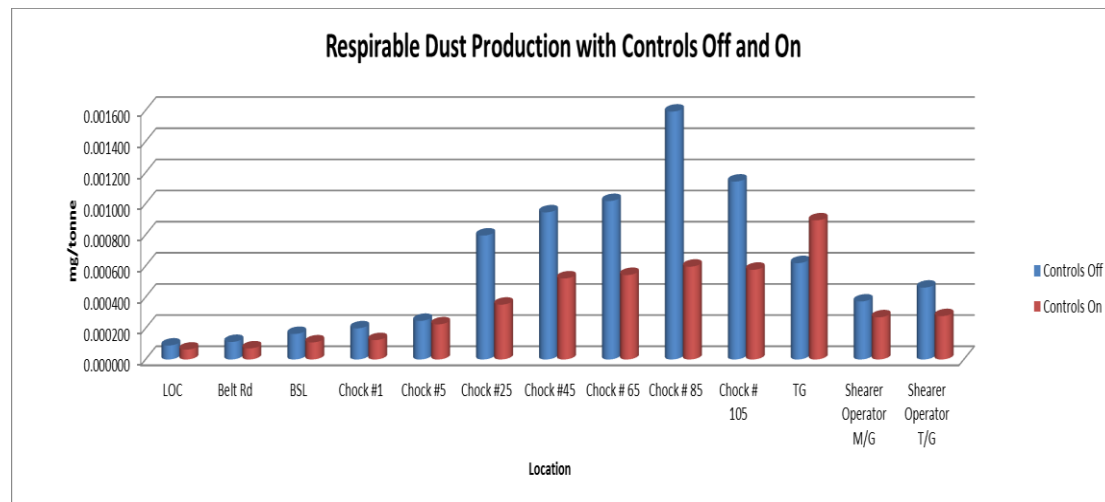
Table 8.2 details the results obtained by Coal Services for collection of the respirable and inhalable samples. Appendix 8 shows the results as supplied by Coal Services. These results were entered into the DME formula, with the results discussed in detail in this chapter.

**Table 8.2 Mine A Respirable And Inhalable Dust Raw Data**

<b>Respirable Dust</b>	<b>Controls Off mg/tonne</b>	<b>Controls On mg/tonne</b>
LOC	0.179	0.127
Belt Rd	0.225	0.142
BSL	0.328	0.219
Chock #1	0.4	0.249
Chock #5	0.496	0.451
Chock #25	1.592	0.704
Chock #45	1.89	1.041
Chock # 65	2.035	1.085
Chock # 85	3.184	1.192
Chock # 105	2.285	1.152
TG	1.238	1.787
Shearer Operator M/G	0.745	0.542
Shearer Operator T/G	0.923	0.557
<b>Inhalable Dust</b>	<b>Controls Off mg/tonne</b>	<b>Controls On mg/tonne</b>
LOC	0.601	1.005
Belt Rd	1.19	0.822
BSL	1.005	6.535
Chock #1	49.107	5.386
Chock #5	117.908	2.567
Chock #25	9.878	9.736
Chock #45	18.594	5.089
Chock # 65	14.583	19.775
Chock # 85	11.364	7.315
Chock # 105	8.825	0
TG	25.208	31.557
Shearer Operator M/G		
Shearer Operator T/G		

### 8.2.2 Respirable Dust Analysis

Figure 8.1 summarises the collected data at Mine A for respirable dust with controls off and on.



**Figure 8.1 Mine A Respirable Dust Production Controls Off and On**

### 8.2.3 Respirable DME Discussion

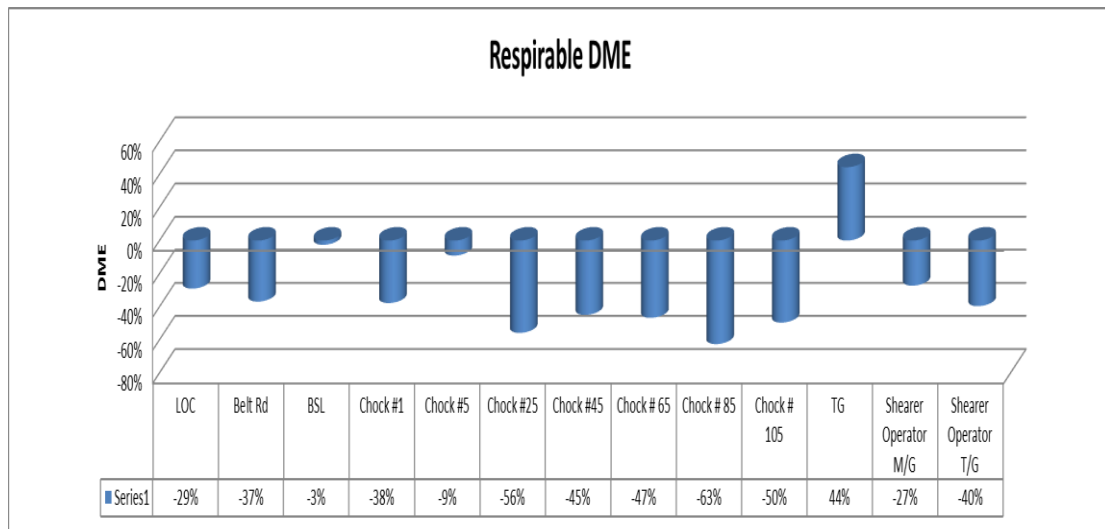
Figure 8.2 summarises the respirable DME at each independent source of dust generation tested at Mine A.

The results for the last open cut-through indicate that there was a *decrease* in respirable dust levels of 29% with the belt road showing a 37% *decrease*. The BSL results show a *decrease* of 3% of respirable dust levels with installed controls operating and at the maingate chock, or chock #1, respirable levels *decreased* by 38%. Chock #5 showed a respirable dust level *decrease* of 9% with controls operating. Chock # 5 respirable levels have remained high as this is the point on the face where crusher dust is forced along the face due to the maingate corner sprays and maingate wing forcing the ventilation further along the face. Chock # 25 showed a 56% decrease in respirable dust with controls on and at chock # 45, respirable levels was *decreased* by 45%. Results at chock # 65 indicate a 47% *decrease* in dust loads with

**CHAPTER EIGHT**  
Data Analysis and Discussion

controls on. Chock # 85 sees a *decrease* in respirable dust of 63% with controls on and Chock # 105 showed a *decrease* in respirable dust of 50%.

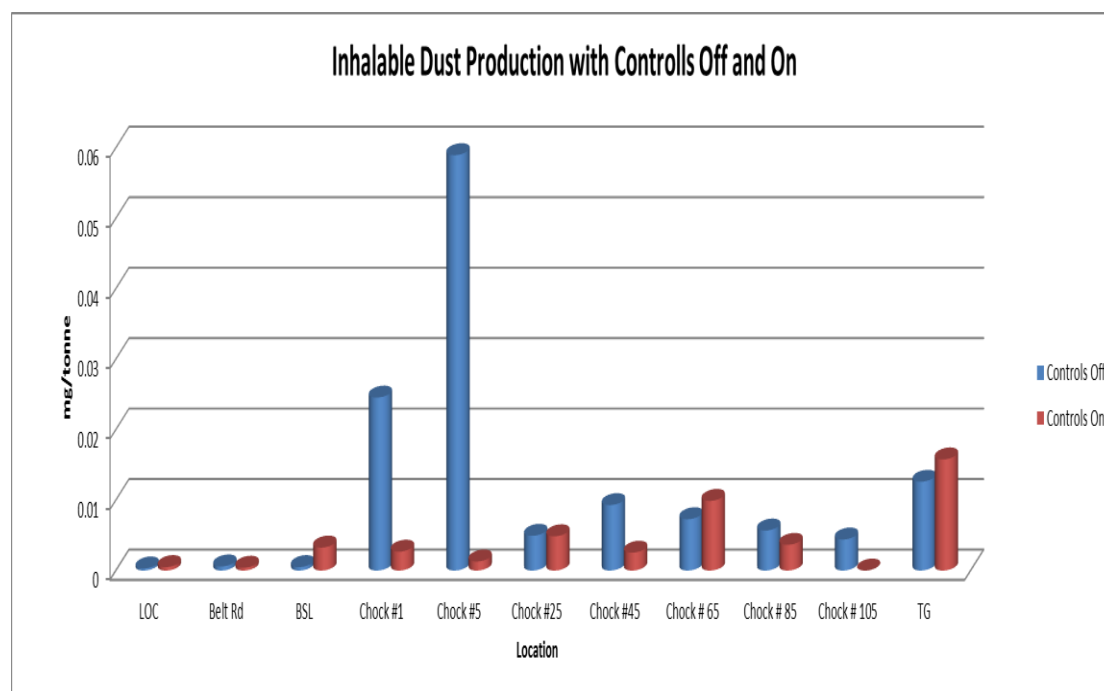
Finally, the tailgate tests have shown to be the most interesting with an actual *increase* in respirable dust loads. The respirable fraction *increased* 44% with the controls on.



**Figure 8.2 Mine A Respirable DME**

**8.2.4 Inhalable Dust Analysis**

Figure 8.3 summarises the collected data at Mine A for inhalable dust with controls off and on.



**Figure 8.3 Mine A Inhalable Dust Production**

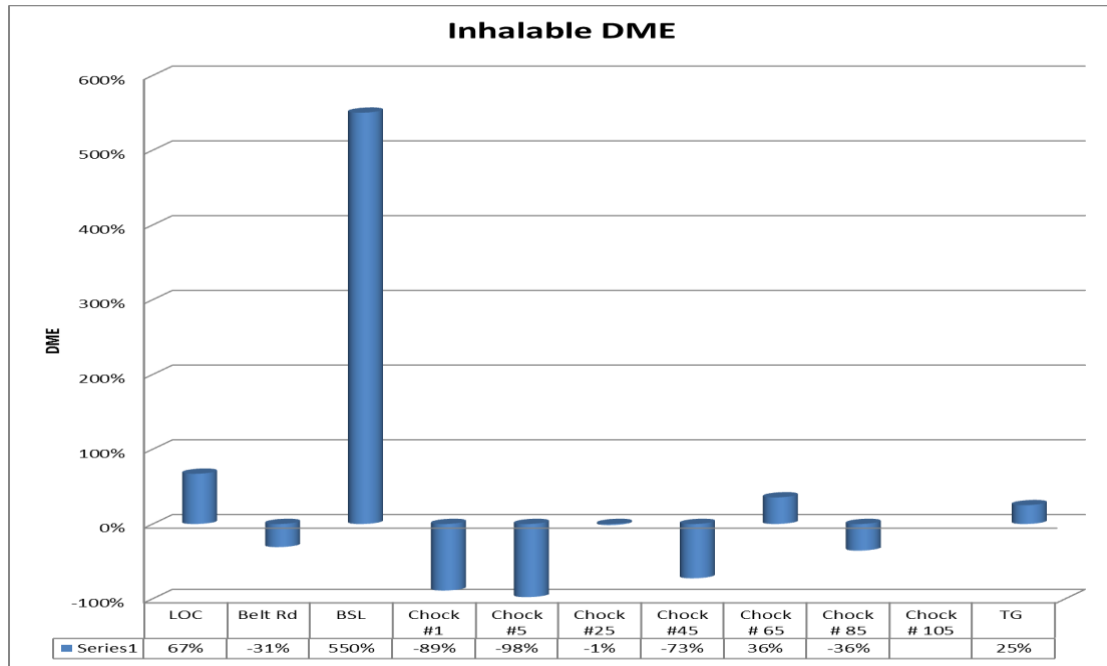
### 8.2.5 Inhalable DME Discussion

Figure 8.4 summarises the inhalable DME at each independent source of dust generation tested at Mine A.

The LOC showed an *increase* in inhalable dust levels of 67%. This increase in inhalable dust loads may be the result of increased outbye activity on the travel road. The belt road inhalable test results indicate a 31% *decrease* in dust levels. However, inhalable results at the BSL discharge show a significant *increase* in dust levels by 550%. This result will need to be retested as the increase is unexplainable to this level. Chock #1 showed an Inhalable level *decrease* by 89% with controls on and Chock #5 experienced a 98% *decrease* in inhalable dust loads with controls operating. Chock #25 showed a marginal *decrease* in inhalable dust of 1% with controls on. Inhalable dust at Chock #45 *decreased* by 73% with controls on. This number seems exceptionally high when compared to the samples collected on chock # 65 which showed an *increase* in inhalable dust loads of 36% with controls on. Chock #85 also sees a *decrease* of 36% with controls on, whilst the inhalable sample at Chock #105

**CHAPTER EIGHT**  
Data Analysis and Discussion

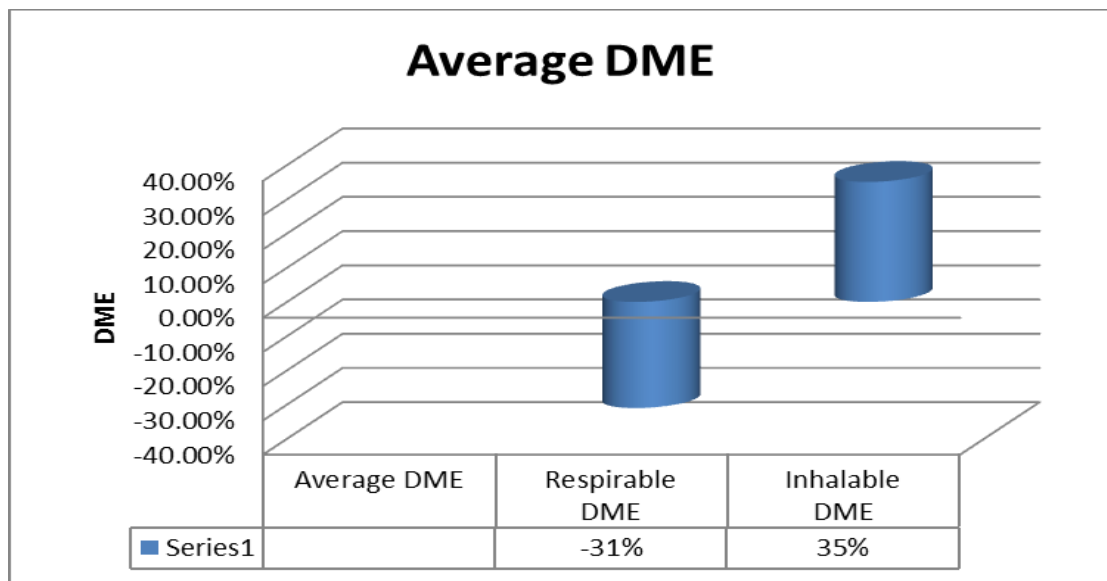
was invalid as the sample was dropped in water. Inhalable fractions *increased* 25% with controls on.



**Figure 8.4 Mine A Inhalable DME**

**8.2.6 Respirable and Inhalable Average DME**

Figure 8.5 summarises the average respirable and inhalable DME.



**Figure 8.5 Mine A Average Respirable and Inhalable DME**

### **8.2.7 Average DME Discussion**

The testing has shown that the current installed controls have an average efficiency of 31% for the *decrease* of respirable dust from the atmosphere whilst a 35% *increase* in the average inhalable dust into the atmosphere was measured.

### **8.2.8 Summary**

Mine A has seen an average *decrease* in the amount of respirable dust of 31% when installed engineering controls are operating. This indicates that installed engineering controls selection and location in and around the identified sources of dust generation are working effectively to reduce the exposure levels of employees to harmful particles of less than 10µm in size. Correspondingly, greater than 10µm particles which represent the inhalable fraction have significantly *increased* by 35% with installed controls operating at the same identified sources of dust generation. This would indicate that although the controls are effective for removing the smaller dust particles from the atmosphere, they are also responsible for increasing the inhalable size dust fraction into the atmosphere.

For Mine A, it is suggested that smaller orifice sprays be utilised with a lower flow and higher pressure to promote greater agglomeration of the inhalable size fractions. Further testing to quantify the results will need to be obtained.

## **8.3 Results Mine B Test 2**

Mine B was the second mine sampled using the new testing methodology. Only 1 set of samples were taken and these were collected by Coal Services under the direction of the author. Coal Services also prepared the filters as per AS2985 with post weighing being performed under this guideline as well. Analysis and calculations were performed by the author as described in 6.3.7.



### 8.3.1 Respirable and Inhalable Dust Results from Coal Services

Samplers were set up in pairs (Respirable and Inhalable) to measure the potential airborne dust in both fractions, during particular cutting operations. The location of samplers were at the first cut-through O/B of the face line, the Pantech Sled, 5 metres O/B crusher motor, # 2 Chock, #20 Chock, #40 Chock, # 60 Chock, #80 Chock, #94 Chock and the on the shearer operator.

Ventilation readings were taken at most static sampling locations. The first trial was undertaken with all water facilities operating and for a complete shear.

The second trial was undertaken with only the High pressure water pump sprays dedicated to the shearer drums – this is required as part of the frictional ignition management plan.

Tables 8.3 and 8.4 are a summary of results supplied by Coal Services. Trial 1 result with & without water - 750 tonnes produced with water on; Trial 2, 600 tonnes produce with water off.

**Table 8.3 Mine B Respirable Results Coal Services**

RESPIRABLE DUST RESULTS – all pumps were set to run at 2.2 litres per minute				
Position of sampler	With Water (Mg) (A)	Without Water(Mg)(B)	Difference (Mg) (B-A)	Ventilation (m <sup>3</sup> /s)
Shearer Driver	0.251	0.432	0.181	N/A
# 94 Chock	Void *	0.746		N/A
# 80 Chock	0.602	0.760	0.158	26.7 m <sup>3</sup> /s
# 60 Chock	0.557	0.392	0.165	24.7 m <sup>3</sup> /s
# 40 Chock	0.464	0.652	0.188	23 m <sup>3</sup> /s
# 20 Chock	0.222	0.325	0.103	23 m <sup>3</sup> /s
# 2 Chock	0.111	0.152	0.041	#6 Chock – 25 m <sup>3</sup> /s
5 metres O/B crusher motor	0.099	0.109	0.010	N/A
Pantech Sled O/B Bootend	1.048	0.109	0.939	N/A
10 metre A5 – B5 (C/T)	0.058	0.060	0.002	20.0 m <sup>3</sup> /s

\* Cyclone heavily influenced by water – chock washed down during sample

## CHAPTER EIGHT

### Data Analysis and Discussion

# Ventilation reading taken at M/G Chock to determine quantity entering goaf – 3 m<sup>3</sup>/s.

**Table 8.4 Mine B Inhalable Results Coal Services**

INHALABLE DUST RESULTS – all pumps were set to run at 2.0 litres per minute				
Position of sampler	With Water (Mg) (A)	Without Water(Mg)(B)	Difference (Mg) (B-A)	Ventilation (m <sup>3</sup> /s)
Shearer Driver	2.528	2.469	0.059	N/A
# 94 Chock	4.179	3.944	0.235	N/A
# 80 Chock	3.933	3.100	0.833	26.7 m <sup>3</sup> /s
# 60 Chock	2.080	2.300	0.220	24.7 m <sup>3</sup> /s
# 40 Chock	6.113	2.097	4.016	23 m <sup>3</sup> /s
# 20 Chock	2.126	1.657	0.103	23 m <sup>3</sup> /s
# 2 Chock	0.250	0.353	0.103	#6 Chock – 25 m <sup>3</sup> /s
5 metres O/B crusher motor	0.260	Void **		N/A
Pantech Sled O/B Bootend	0.168	0.393	0.225	N/A
10 A5 – B5 (C/T)	0.153	0.260	0.107	20.0 m <sup>3</sup> /s

\*\* Sampler dropped in water during recovery

#### RAW DATA RESULTS.

Respirable dust loadings showed an increase with water turned off in 6 of the 10 sampling locations, with 1 result voided due to large ingress of water on sampling medium. Inhalable dust loadings showed an increase with water turned off in 5 of the 10 sampling locations, with 1 result voided as samplers was dropped in a water hole.

Report by Peter Adlington from Coal Services

### 8.3.2 Respirable and Inhalable Dust Raw Data

Table 8.5 summarises the raw data collected by Coal Services.

**CHAPTER EIGHT**  
Data Analysis and Discussion

---

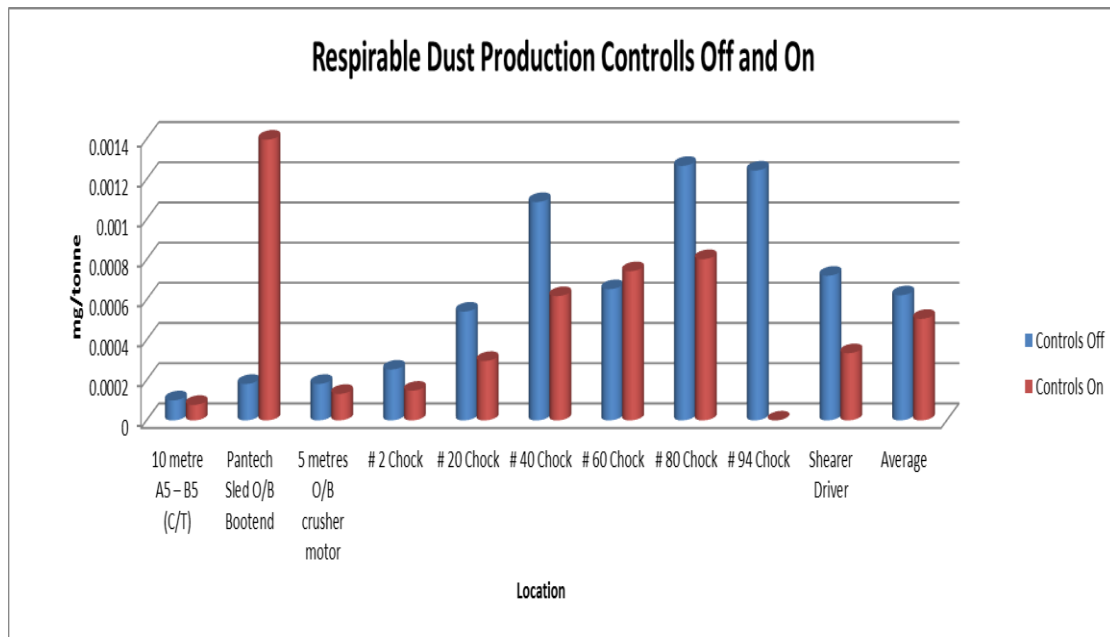
**Table 8.5 Mine B, Test 2 Respirable and Inhalable Dust Raw Data**

<b>Respirable Dust</b>	<b>Controls Off mg/tonne</b>	<b>Controls On mg/tonne</b>
10 metre A5 – B5 (C/T)	0.06	0.058
Pantech Sled O/B Bootend	0.109	1.048
5 metres O/B crusher motor	0.109	0.099
# 2 Chock	0.152	0.111
# 20 Chock	0.325	0.222
# 40 Chock	0.652	0.464
# 60 Chock	0.392	0.557
# 80 Chock	0.76	0.602
# 94 Chock	0.746	Void *
Shearer Driver	0.432	0.251
Average	0.3737	0.379
<b>Inhalable Dust</b>	<b>Controls Off mg/tonne</b>	<b>Controls On mg/tonne</b>
10 metre A5 – B5 (C/T)	0.26	0.153
Pantech Sled O/B Bootend	0.393	0.168
5 metres O/B crusher motor	Void **	0.26
# 2 Chock	0.353	0.25
# 20 Chock	1.657	2.126
# 40 Chock	2.097	6.113
# 60 Chock	2.3	2.08
# 80 Chock	3.1	3.933
# 94 Chock	3.944	4.179
Shearer Driver	2.469	2.528
Average	1.84	2.179

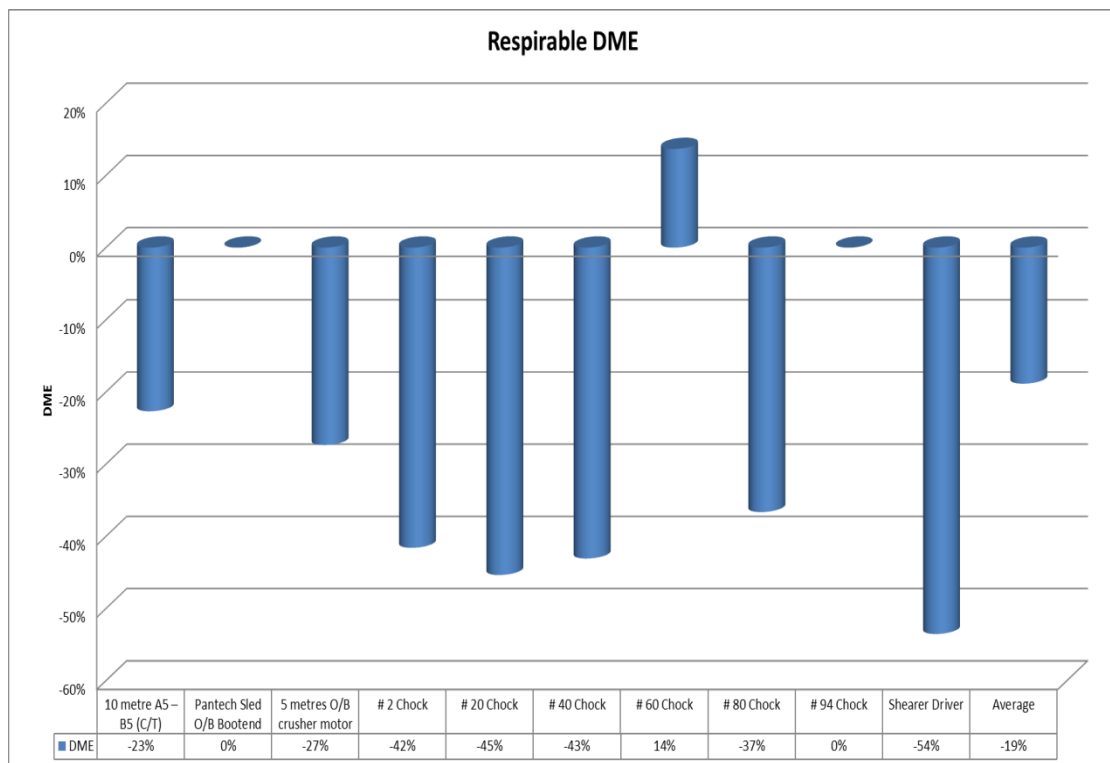
### 8.3.3 Respirable Dust Analysis

Figure 8.6 summarises the respirable data collected for Mine B. Figure 8.7 summarises the respirable DME for Mine B.

**CHAPTER EIGHT**  
Data Analysis and Discussion



**Figure 8.6 Mine B, Test 2 Respirable Dust Production**



**Figure 8.7 Mine B, Test 2 Respirable DME**

**8.3.4 Respirable DME Discussion**

The last open cut-through showed a respirable dust *decrease* of 23% with installed engineering controls operating whilst the belt road needs to be retested as the sample

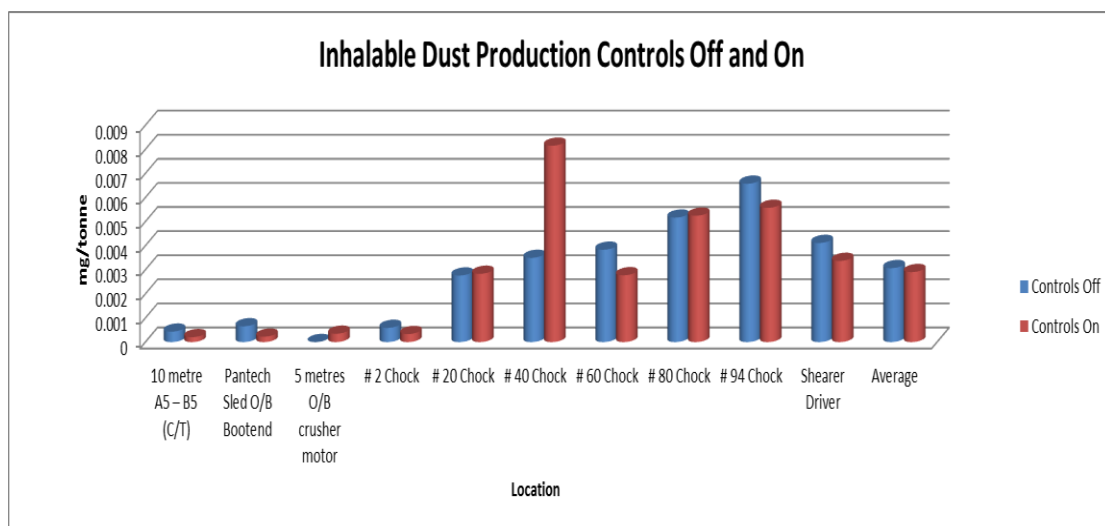
## CHAPTER EIGHT

### Data Analysis and Discussion

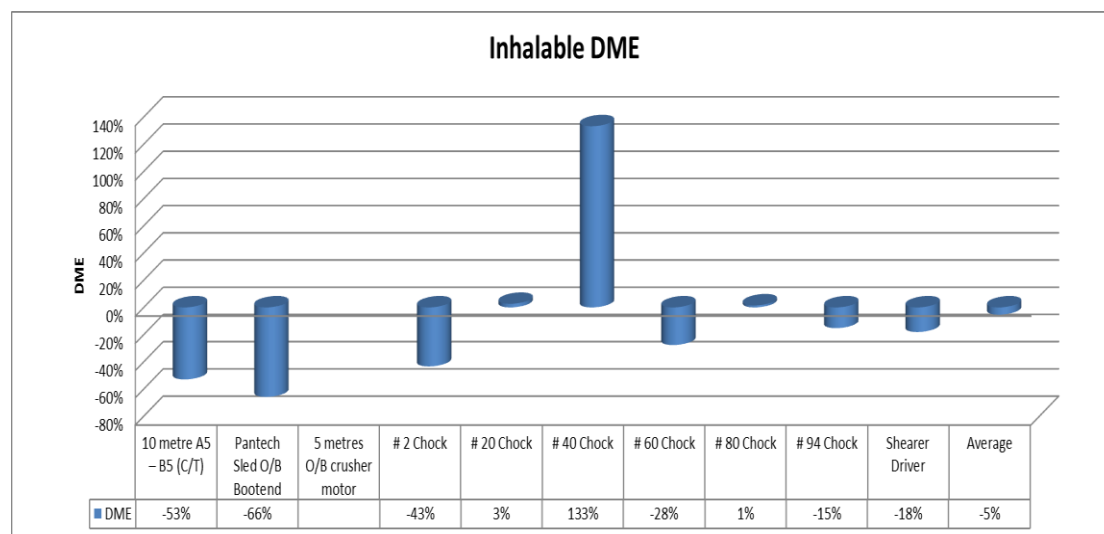
collected by Coal Services was excessively high indicating either an incorrect reading or contamination. Inbye of the BSL discharge showed a *decrease* of 27% for respirable dust while the respirable readings along the face showed a *decrease* of between 37 and 45% with the exception of chock 60 which showed an *increase* of 14%. This could be attributed to chock movement.

### 8.3.5 Inhalable Dust Analysis

Figure 8.8 summarises the inhalable data collected for Mine B. Figure 8.9 summarises the inhalable DME for Mine B.



**Figure 8.8 Mine B, Test 2 Inhalable Dust Production**



**Figure 8.9 Mine B, Test 2 Inhalable DME**

### 8.3.6 Inhalable DME Discussion

The LOC showed a *decrease* in inhalable dust of 53%. This indicates that the ventilation, as the only form of mitigation, is performing as required. The belt road showed a *decrease* of 66% for inhalable dust, and the BSL discharge returned a void sample for inhalable dust fractions. This needs to be retested. The inhalable fractions were less effective with *decreases* of 15% at chock 94 and 43% at chock 2 whilst *increases* at chocks 20, 40 and 80 with a 3%, 133% and 1% increase respectively were experienced.

### 8.3.7 Average DME Discussion

The testing has shown that the current installed engineering controls have an average Dust Mitigation Efficiency (DME) of 19% for the removal of respirable dust and 5% for the removal of inhalable dust from the atmosphere.

### 8.3.8 DME Conclusion

From this testing, a benchmark in mg/tonne produced has been established for both respirable and inhalable dust. Average respirable dust mitigation of 19% indicates that the installed controls are performing adequately. Further analysis of alternative products will be required to mitigate further dust. However, the installed controls only remove 5% of the inhalable fraction which indicates that significant product analysis

is required to increase mitigation efficiencies. This will be achieved by further comprehensive testing of dust mitigation products to determine required efficiencies.

## **8.4 Results Mine C Test 3**

Mine C was the third mine tested and was the first mine to be tested using equipment purchased by the University of Wollongong. The equipment used is detailed in chapter 6, section 6.4.1. Respirable dust loads were taken; however, inhalable samples were not taken as approval for the SKC pumps was given under the mines unapproved electrical apparatus scheme, but the Dupont pumps MDA approval was not provided, so approval was not issued for underground use. Further samples were taken at Mine C which included inhalable samples and these are discussed later in this chapter.

### **8.4.1 Respirable Dust Raw Data**

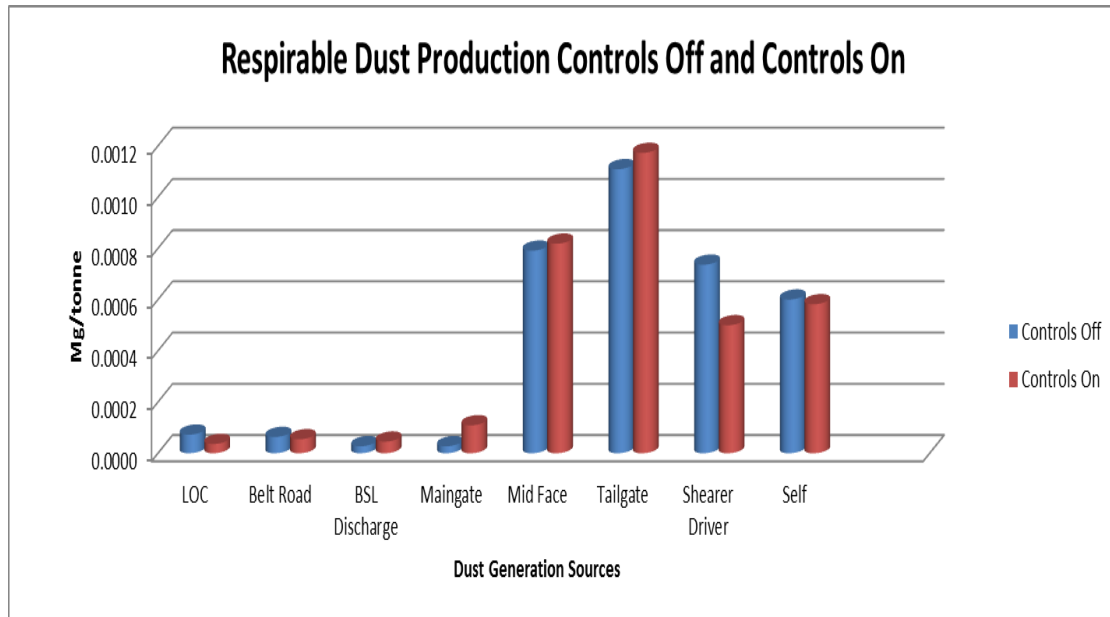
Table 8.6 summarises the raw data collected for respirable dust production analysis at Mine C.

**Table 8.6 Mine C, Test 3 Respirable Dust Raw Data**

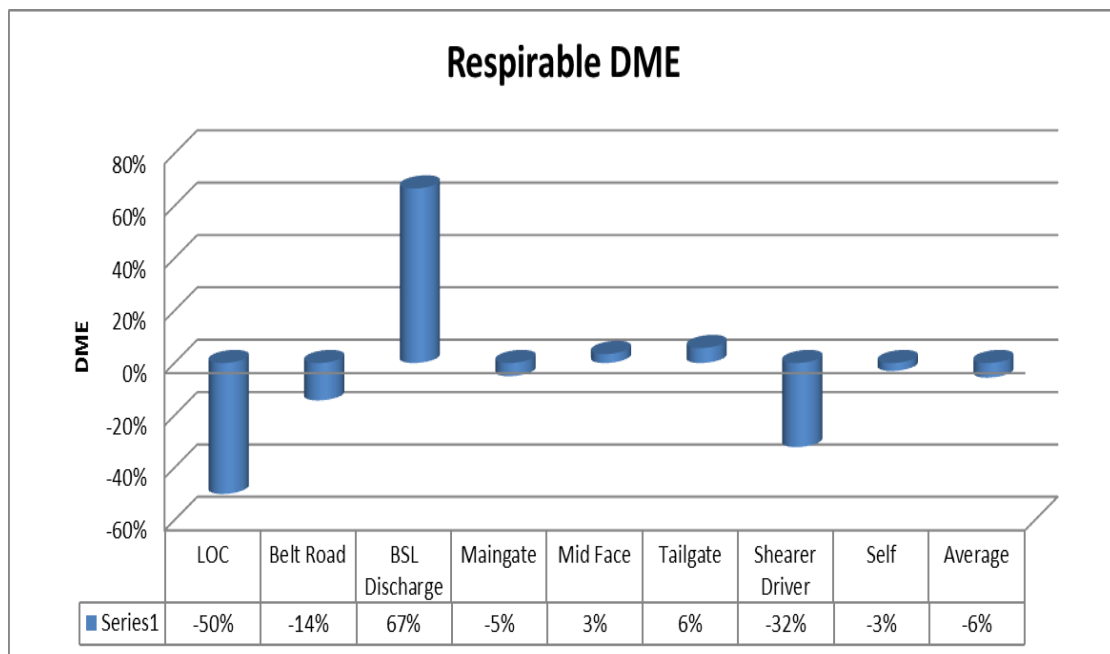
<b>Sample ID</b>		<b>Initial Weight</b>	<b>Final Weight</b>	<b>Net weight</b>
AWRD1	LOC	5.18	5.26	0.08
AWRD2	Belt Road	4.86	4.93	0.07
AWRD3	Inbye Discharge	5.89	5.92	0.03
AWRD4	Maingate	6.31	6.34	0.03
AWRD5	Mid Face On	5.12	5.99	0.87
AWRD6	Tailgate On	5.94	7.16	1.22
AWRD7	Shearer Driver On	5.46	6.27	0.81
AWRD8	Shadow	5.43	6.09	0.66
2AWRD1	LOC	5.82	5.86	0.04
2AWRD2	Belt Road	4.85	4.91	0.06
2AWRD3	Inbye Discharge	5.32	5.37	0.05
2AWRD4	Maingate	5.92	6.04	0.12
2AWRD5	Mid Face Off	4.65	5.55	0.9
2AWRD6	Tailgate Off	6.05	7.34	1.29
2AWRD7	Shearer Driver Off	5.32	5.87	0.55
2AWRD8	Shadow	5.46	6.10	0.64

### 8.4.2 Respirable Dust Analysis

Figure 8.10 summarises the respirable data collected for Mine C. Figure 8.11 summarises the respirable DME for Mine C.



**Figure 8.10 Mine C, Test 3 Respirable Dust Production**



**Figure 8.11 Mine C, Test 3 Respirable DME**



### **8.4.3 Respirable DME Discussion**

The testing has shown that the current installed engineering controls *decrease* the amount of respirable dust in the atmosphere by an average of 6%. The last open cut-through showed a respirable dust *decrease* of 50% with installed engineering controls operating. This indicates that the ventilation, as the only form of dust mitigation, is performing as required. The belt road showed a *decrease* of 14% for respirable dust. Inbye of the BSL discharge showed an *increase* of 67% for respirable dust, whilst the maingate showed a *decrease* in respirable dust of 5%. Midface and the tailgate showed an *increase* in respirable dust loads of 3% and 6% respectively, whilst the shearer driver showed a 32% *decrease* in respirable dust loads and the author, who was shadowing the shearer operator approximately 2m further outbye, showed a *decrease* in respirable dust loads of 3%.

### **8.4.4 DME Conclusion**

The increase in the amount of respirable dust produced when installed engineering controls are turned on indicates that the type, position, pressure or flow of the discharge hood sprays need attention. Shearer operator positioning reduces the amount of potential harmful dust exposure to the operator significantly. Increases in midface and at the tailgate can be attributed to chock movement.

### **8.5 Results Mine C Test 4**

Mine C was also the fourth mine tested and this was effectively a re-test of Test 3 to include inhalable samples. This test was performed exactly the same as Test 3 with pump and monitor placement mirroring Test 3, with the exclusion of the shearer driver and this author shadowing the shearer driver. The reason for this is that the shearer driver would resist wearing two sets of pumps and heads for respirable and inhalable sampling.

### 8.5.1 Respirable and Inhalable Dust Raw Data

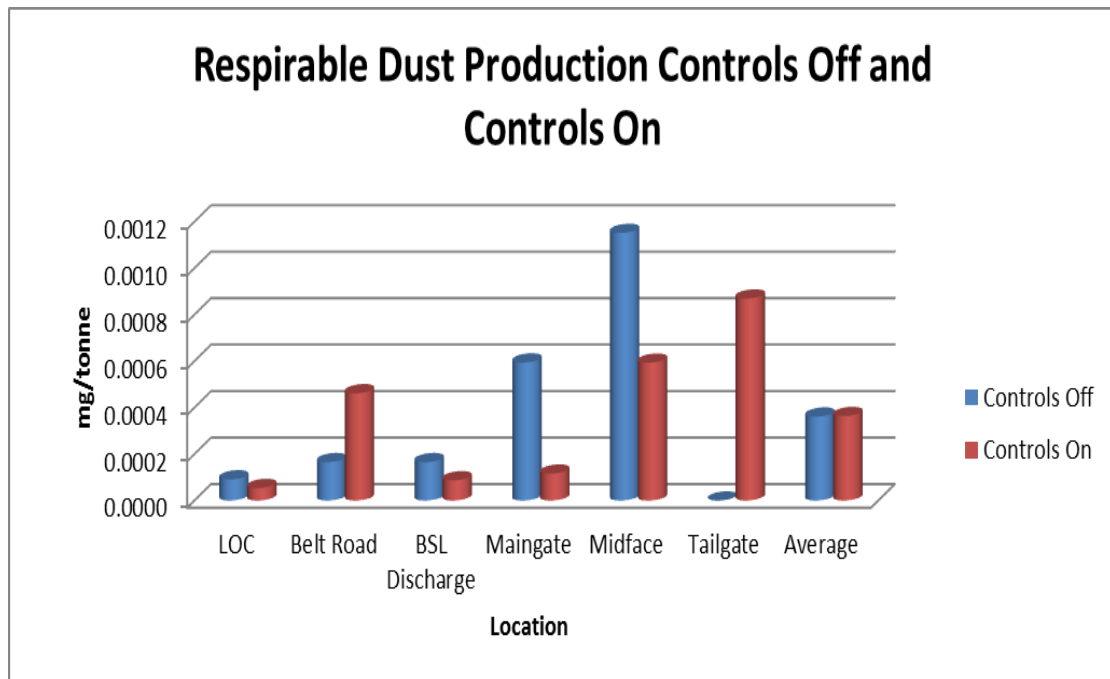
Table 8.7 summarises the raw data collected for respirable and inhalable dust production analysis at Mine C.

**Table 8.7 Mine C, Test 4 Respirable And Inhalable Raw Data**

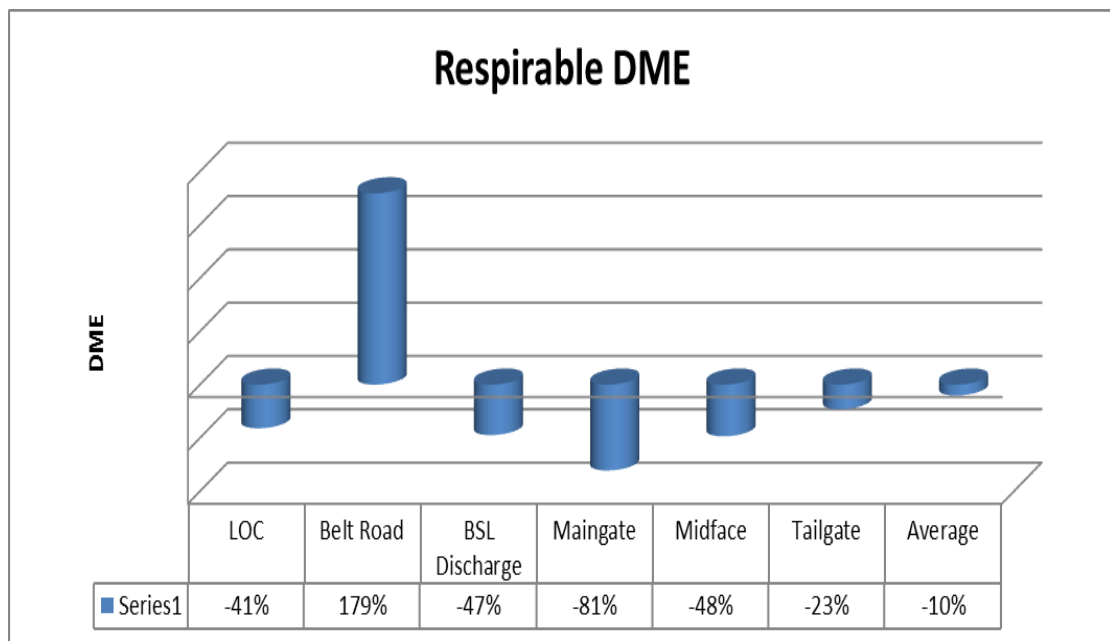
<u>Respirable Dust - Controls Off</u>				<u>Respirable Dust - Controls On</u>			
Sample ID	Initial Weight	Final Weight	Net weight	Sample ID	Initial Weight	Final Weight	Net weight
LOC	7.08	7.18	0.1000	LOC	6.94	7.00	0.0591
Belt Road	7.62	7.80	0.1817	Belt Road	7.19	7.70	0.5076
BSL Discharge	7.54	7.72	0.1817	BSL Discharge	7.86	7.96	0.0957
Maingate	6.98	7.63	0.6533	Maingate	7.91	8.04	0.1272
Midface	7.97	9.24	1.2667	Midface	7.45	8.10	0.6524
Tailgate	6.54	7.78	1.2433	Tailgate	7.54	8.50	0.9563
<u>Inhalable Dust - Controls Off</u>				<u>Inhalable Dust - Controls On</u>			
Sample ID	Initial Weight	Final Weight	Net weight	Sample ID	Initial Weight	Final Weight	Net weight
LOC	7.64	8.15	0.5128	LOC	7.43	7.82	0.3943
Belt Road	7.55	7.90	0.3538	Belt Road	7.09	7.60	0.5133
BSL Discharge	8.09	8.62	0.5333	BSL Discharge	6.99	7.57	0.5763
Maingate	6.99	7.92	0.9282	Maingate	7.85	8.95	1.0984
Midface	6.78	8.05	1.2718	Midface	7.25	9.64	2.3899
Tailgate	7.01	11.92	4.9077	Tailgate	7.77	13.15	5.3769
Tonnes	1100						

### 8.5.2 Respirable Dust Analysis

Figure 8.12 summarises the respirable data collected for Mine C. Figure 8.13 summarises the respirable DME for Mine C.



**Figure 8.12 Mine C, Test 4 Respirable Dust Production**



**Figure 8.13 Mine C, Test 4 Respirable DME**

### 8.5.3 Respirable Dust Discussion

The last open cut-through showed a respirable dust *decrease* of 41% with installed engineering controls operating. This indicates that the ventilation, as the only form of dust mitigation, is performing as required and is a similar reading to the Test 3. However, the belt road showed an *increase* of 179% for respirable dust. This is a huge increase in respirable dust loads and would indicate that a significant change or activity was present during test 2 at Mine C, considering the respirable DME in Test 3 at this location showed a *decrease* in respirable dust production of 14%. Inbye of the BSL discharge showed a *decrease* of 47% for respirable dust, which is again a significant reduction in respirable dust production from Test 3 which showed a 67% *increase*. The maingate showed a *decrease* in respirable dust of 81%, which is a significant improvement on the 5% *decrease* measured in Test 3. Midface and the tailgate showed a *decrease* in respirable dust loads of 48% and 23% respectively, compared to a 3% and 6% *increase* measured in Test 3.

### 8.5.4 Inhalable Dust Analysis

Figure 8.14 summarises the inhalable data collected for Mine C. Figure 8.15 summarises the inhalable DME for Mine C.

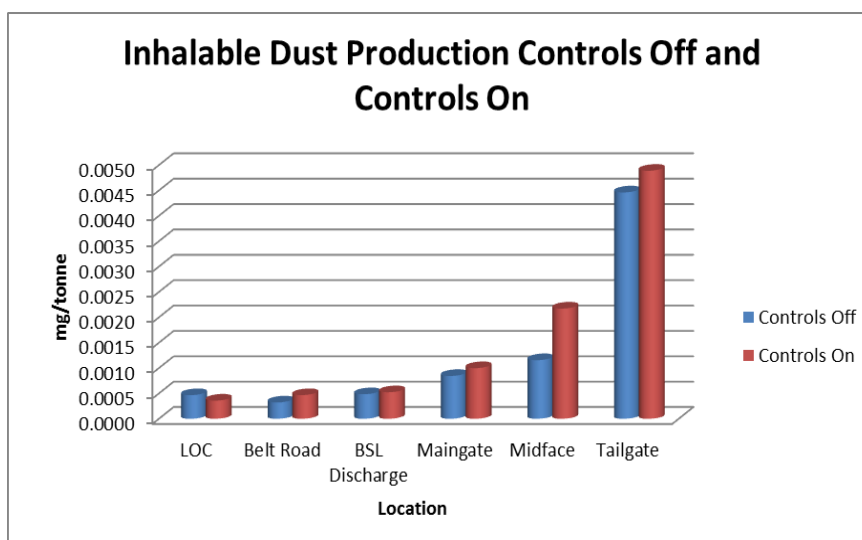
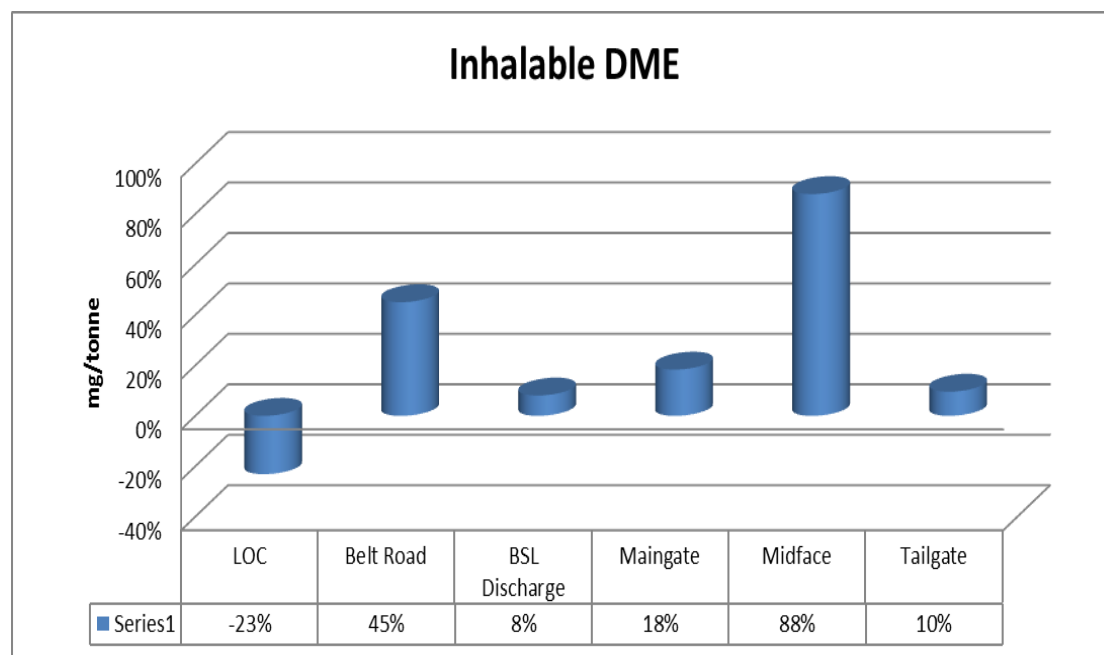


Figure 8.14 Mine C, Test 4 Inhalable Dust Production



**Figure 8.15 Mine C, Test 4 Inhalable DME**

### 8.5.5 Inhalable Dust Discussion

The LOC showed a 23% *decrease* in inhalable DME, whilst the belt road showed a 45% *increase*. Further investigations need to be undertaken to determine if a roller was changed, sprays were not working or if some other activity created this increase in inhalable dust loads. Inhalable dust showed a slight *increase* to 8% with installed controls operating at the BSL discharge, with the maingate showing an *increase* of 18%. Inhalable dust showed an *increase* midface and at the tailgate of 88% and 10% respectively. These results indicate that the current installed controls for mitigating inhalable dust need significant improvement.

### 8.5.6 Average DME Discussion

The testing has shown that the current installed engineering controls *decrease* the amount of respirable dust in the atmosphere by an average of 10%. This is a marginal increase in the amount of respirable dust mitigated from Test 3. This is a positive trend and shows that implemented changes have had an effect on the DME of installed controls. The corresponding inhalable average DME showed an *increase* in inhalable dust production of 24%. There was no inhalable data to compare this to in

Test 3, however, the fact that the inhalable fraction increased is a significant issue and needs to be addressed immediately.

### **8.5.7 DME Conclusion**

Mine C has seen an average *decrease* in the amount of respirable dust of 10% when installed engineering controls are operating. This indicates that installed engineering controls selection and location in and around the identified sources of dust generation are working effectively to reduce the exposure levels of employees to harmful particles of less than 10µm in size. Correspondingly, greater than 10µm particles which represent the inhalable fraction have significantly *increased* by 24% with installed controls operating at the same identified sources of dust generation. This would indicate that although the controls are effective for removing the smaller dust particles from the atmosphere, they are also responsible for increasing the inhalable size dust fraction into the atmosphere.

## **8.6 Results Mine C Test 5**

Mine C was also the fifth mine tested and this was effectively a re-test of Test 4 and also included inhalable samples. This test was performed exactly the same as Test 4 with pump and monitor placement mirroring Test 4.

### **8.6.1 Respirable and Inhalable Dust Raw Data**

Table 8.8 summarises the raw data collected for respirable and inhalable dust production for Mine C.

## CHAPTER EIGHT

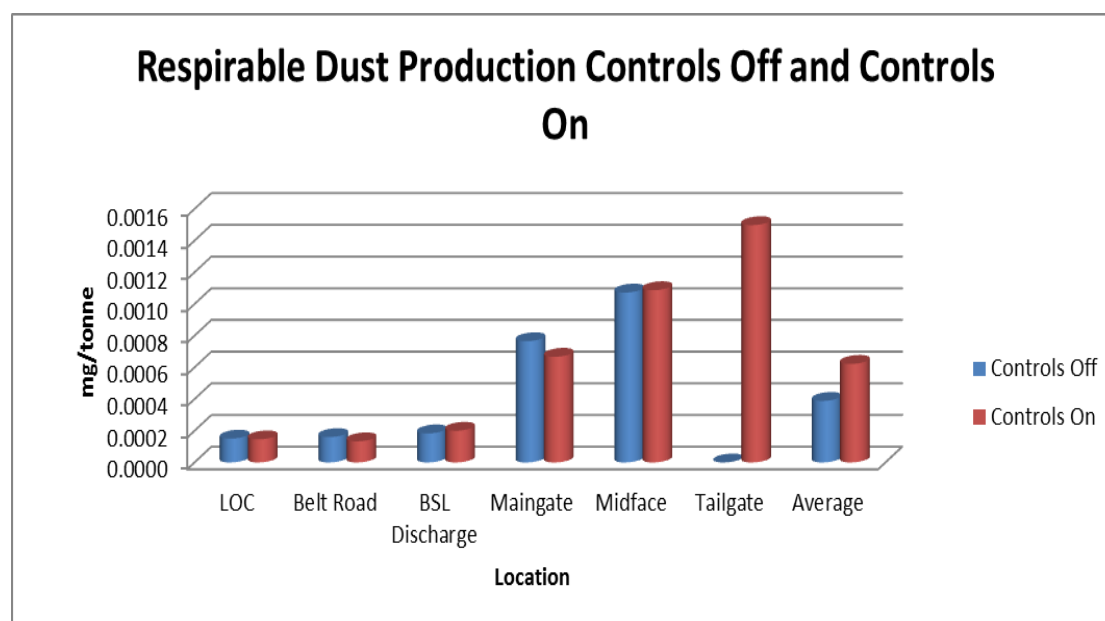
### Data Analysis and Discussion

**Table 8.8 Mine C, Test 5 Raw Data**

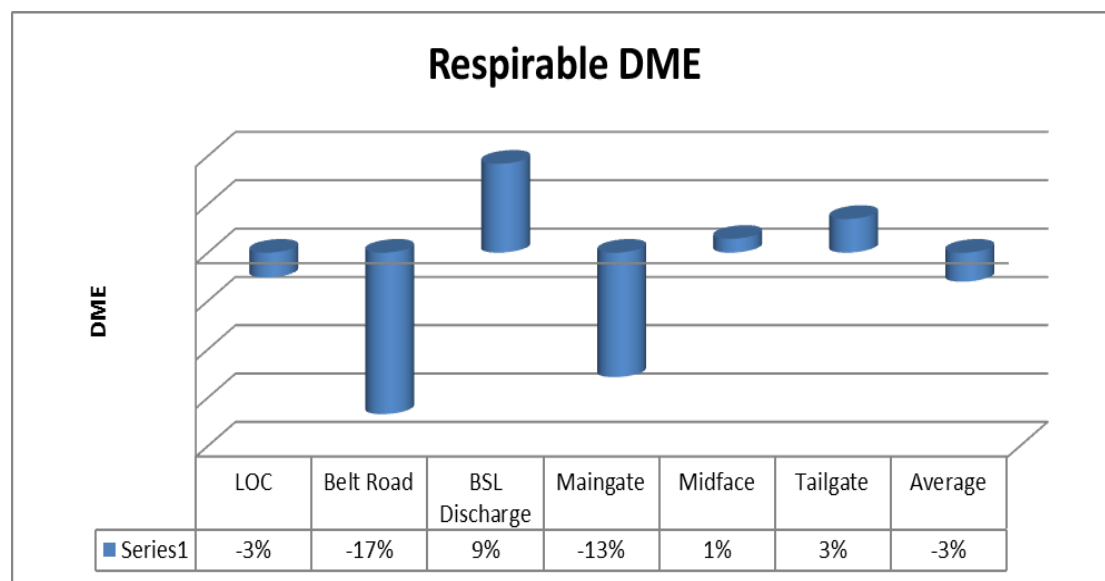
<b>Respirable Dust - Controls Off</b>				<b>Respirable Dust - Controls On</b>			
Sample ID	Initial Weight	Final Weight	Net weight	Sample ID	Initial Weight	Final Weight	Net weight
LOC	7.17	7.34	0.1650	LOC	7.71	7.87	0.1608
Belt Road	7.63	7.81	0.1761	Belt Road	6.91	7.06	0.1467
BSL Discharge	7.09	7.29	0.2015	BSL Discharge	7.79	8.01	0.2200
Maingate	7.8	8.64	0.8416	Maingate	7.37	8.10	0.7333
Midface	6.98	8.16	1.1790	Midface	7.84	9.04	1.1959
Tailgate	7.31	8.90	1.5917	Tailgate	7.44	9.09	1.6472
<b>Inhalable Dust - Controls Off</b>				<b>Inhalable Dust - Controls On</b>			
Sample ID	Initial Weight	Final Weight	Net weight	Sample ID	Initial Weight	Final Weight	Net weight
LOC	7.67	8.21	0.5413	LOC	7.65	8.50	0.8462
Belt Road	8.14	8.65	0.5068	Belt Road	8.01	8.70	0.6938
BSL Discharge	8.23	8.68	0.4506	BSL Discharge	7.99	9.57	1.5767
Maingate	7.98	11.57	3.5947	Maingate	7.61	9.18	1.5738
Midface	7.11	9.46	2.3535	Midface	7.43	9.75	2.3241
Tailgate	7.63	12.14	4.5089	Tailgate	7.62	10.40	2.7810
Tonnes	1100						

### 8.6.2 Respirable Dust Analysis

Figure 8.16 summarises the respirable data collected for Mine C. Figure 8.17 summarises the respirable DME for Mine C.



**Figure 8.16 Mine C, Test 5 Respirable Dust Production**



**Figure 8.17 Mine C, Test 5 Respirable DME**

### 8.6.3 Respirable Dust Discussion

The last open cut-through showed a respirable dust load *decrease* of 3% with the scrubber operating. This indicates that the ventilation, as the only form of dust mitigation, is performing as required. The belt road showed a *decrease* of 17% for respirable dust.

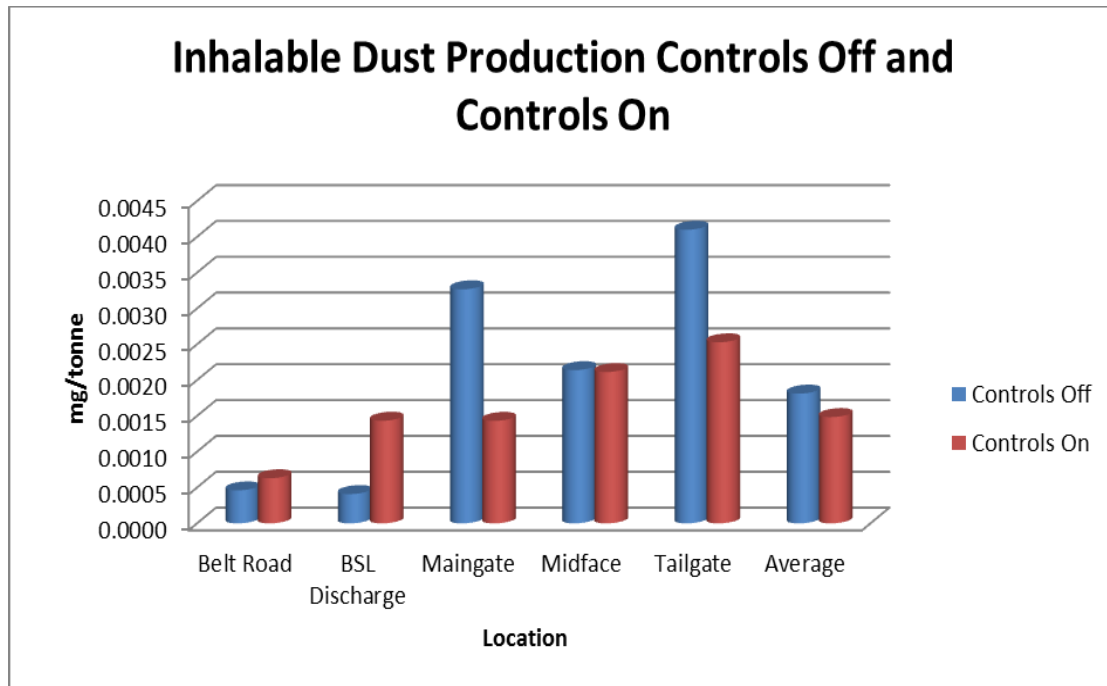
Inbye of the BSL discharge showed an *increase* of 9% for respirable dust. The maingate showed a 13% *decrease* in respirable dust and Midface showed the respirable dust *increase* by 1% with controls operating. The tailgate showed a *decrease* in respirable dust loads of 3%.

The increase in respirable dust at the BSL discharge indicates that the installed sprays are either too big in diameter, are wrongly positioned or have the incorrect pressure and flow to them. Further testing with alternative parametric setup should be performed to understand the issue and determine the most suitable product to ensure respirable dust is removed.

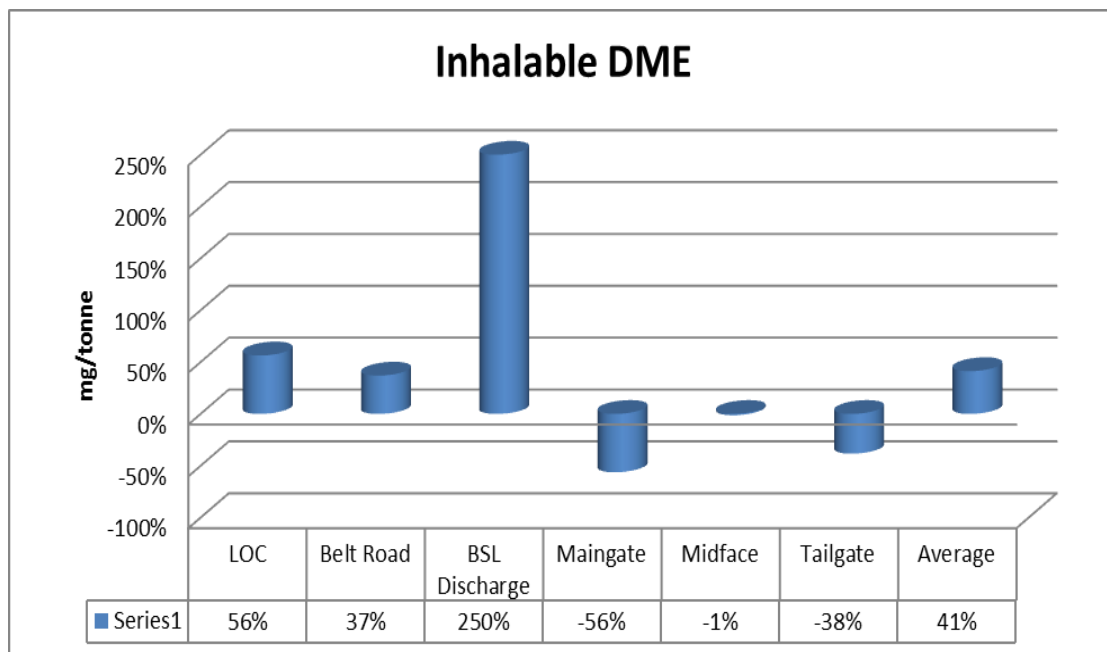


### 8.6.4 Inhalable Dust Analysis

Figure 8.18 summarises the inhalable data collected for Mine C. Figure 8.19 summarises the inhalable DME for Mine C.



**Figure 8.18 Mine C, Test 5 Inhalable Dust Production**



**Figure 8.19 Mine C, Test 5 Inhalable DME**

### **8.6.5 Inhalable Dust Discussion**

The inhalable dust loads showed a 56% *increase* at the LOC indicating that outbye works or some other outbye activity was having a significant effect on the inhalable dust loads being brought to the longwall on the intake ventilation. The belt road inhalable DME also showed a 37% *increase*. Inhalable dust at the BSL discharge was an enormous *increase* of 250%. This result, in conjunction with the increase in respirable dust at the same point indicates a serious problem with installed controls. However, the maingate showed a *decrease* of 56%, along with *decreases* measured midface and at the tailgate of 1% and 38% respectively. These results along the face indicate that installed controls in the maingate area and along the face are successfully mitigating inhalable dust. It should be noted that the BSL discharge needs urgent attention.

### **8.6.6 Average DME Discussion**

Mine C, Test 5 results showed that the operating scrubber *decreased* the respirable dust loads by an average of 3%. The inhalable dust loads showed an *increase* of an average 41%. This increase was due to high LOC and Belt Road readings for the efficiency test. Significant analysis and further testing is required to ensure installed engineering controls actually mitigate dust as opposed to creating it as experienced at this mine.

### **8.6.7 DME Conclusion**

Mine C, Test 5 has seen an average *decrease* in the amount of respirable dust of only 3% when installed engineering controls are operating. This indicates that installed engineering controls selection and location in and around the identified sources of dust generation are working effectively to reduce the exposure levels of employees to harmful particles of less than 10µm in size. Although this is a reduction in respirable dust production, it is only a minor reduction and further product research and testing needs to be urgently undertaken to improve control performance. It should also be noted that the respirable DME has reduced from 10% as seen in Test 4 to 3% in this test. The reason for this decrease in control efficiency needs to be determined.

In contrast, greater than 10 $\mu$ m particles which represent the inhalable fraction have significantly *increased* to 41%, up from 24% with installed controls operating at the same identified sources of dust generation. This would indicate that although the controls are effective for removing the smaller dust particles from the atmosphere, they are also responsible for increasing the inhalable size dust fraction into the atmosphere.

### **8.7 Results Mine B Test 6 – Venturi Sprays, Test 1**

Mine B, Test 6 was undertaken to evaluate the dust mitigation efficiency of a new Venturi system installed at the intake to the crusher in the maingate. A benchmark test was undertaken specifically designed to measure the amount of dust produced during chock movement in the maingate area as the longwall progresses with further sampling taken for venturi sprays installed at the maingate (BSL) and at Chock #6. The DME was determined by establishing the benchmark without the venturi operating and retested with the same operating parameters with the venturi operating.

Testing methodology for this project was based around CFD modelling undertaken at the University of Wollongong. Results of the CFD modelling demonstrated that much of the respirable dust particles generated from MG chock movements and BSL would disperse onto the longwall face ventilation, contributing significantly to dust levels in the longwall face. Modelling results showed that a more effective control of dust particles from MG chocks and BSL can be achieved by installing venturis at the maingate and on chock #6. The simulation results further showed that the sprays on the BSL spill plate when operated at 300 dip (down in vertical plane) and 200 tilt towards the face (air flow direction) a maximum knocked down of dust and dispersion of dust particles towards the face side.

Positioning of the venturi spray for the first test was on the maingate wing facing toward the crusher intake. Testing was undertaken to prove up simulations.

### 8.7.1 Respirable and Inhalable Dust Raw Data

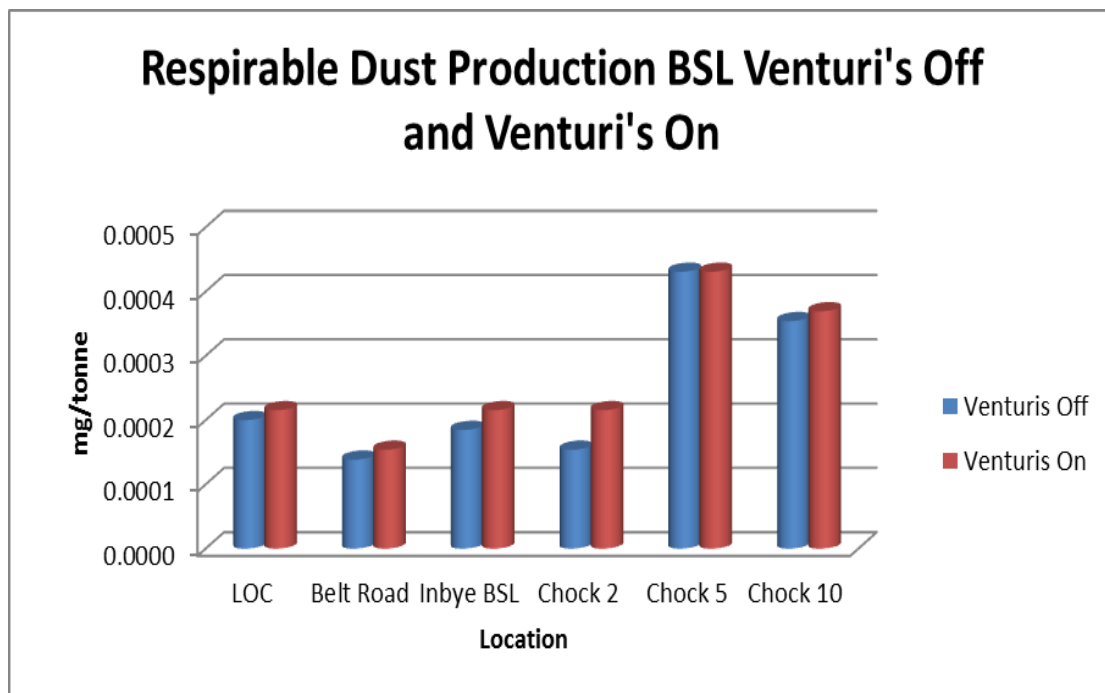
Table 8.9 summarises the raw data collected for respirable and inhalable dust production for Mine B.

**Table 8.9 Mine B, Test 6 Raw Data**

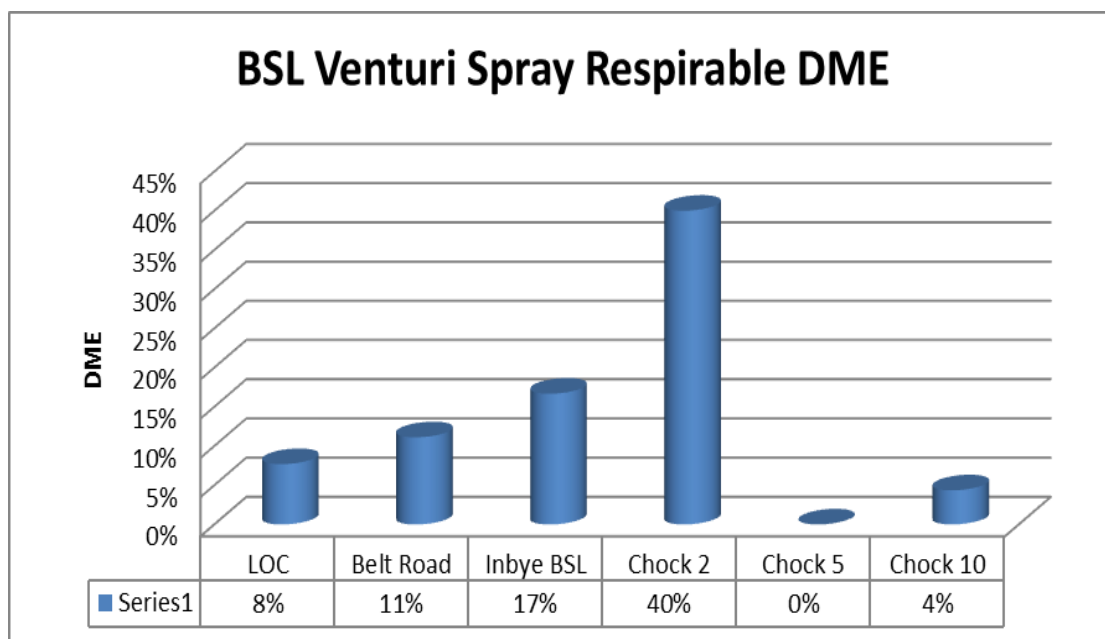
<u>Respirable Dust</u>							
Sample ID	Initial Weight	Final Weight	Net weight	Sample ID	Initial Weight	Final Weight	Net weight
LOC	5.36	5.49	0.13	2LOC	5.05	5.19	0.14
Belt Road	5.42	5.51	0.09	2Belt Road	4.55	4.65	0.1
Inbye BSL	5.34	5.46	0.12	2Inbye BSL	6.03	6.17	0.14
Crusher	5.78	5.88	0.1	2Crusher	5.45	5.59	0.14
Chock 5	6.05	6.33	0.28	2Chock 5	4.89	5.17	0.28
Chock 10	6.36	6.59	0.23	2Chock 10	6.12	6.36	0.24
<u>Inhalable Dust</u>							
Sample ID	Initial Weight	Final Weight	Net weight	Sample ID	Initial Weight	Final Weight	Net weight
LOC	5.91	6.56	0.65	2LOC	4.67	5.32	0.65
Belt Road	6.67	6.86	0.19	2Belt Road	5.45	5.72	0.27
Inbye BSL	6.39	6.66	0.27	2Inbye BSL	4.53	4.99	0.46
Crusher	5.65	5.74	0.09	2Crusher	6	6.17	0.17
Chock 5	5.85	6.38	0.53	2Chock 5	5.34	5.41	0.07
Chock 10	5.58	6.47	0.89	2Chock 10	5.73	5.81	0.08
Tonnes	650						

### 8.7.2 Respirable Dust Analysis

Figure 8.20 summarises the respirable data collected for Mine B. Figure 8.21 summarises the respirable DME for Mine B.



**Figure 8.20 Mine B, Test 6 Respirable Dust Production**



**Figure 8.21 Mine B, Test 6 Respirable DME**

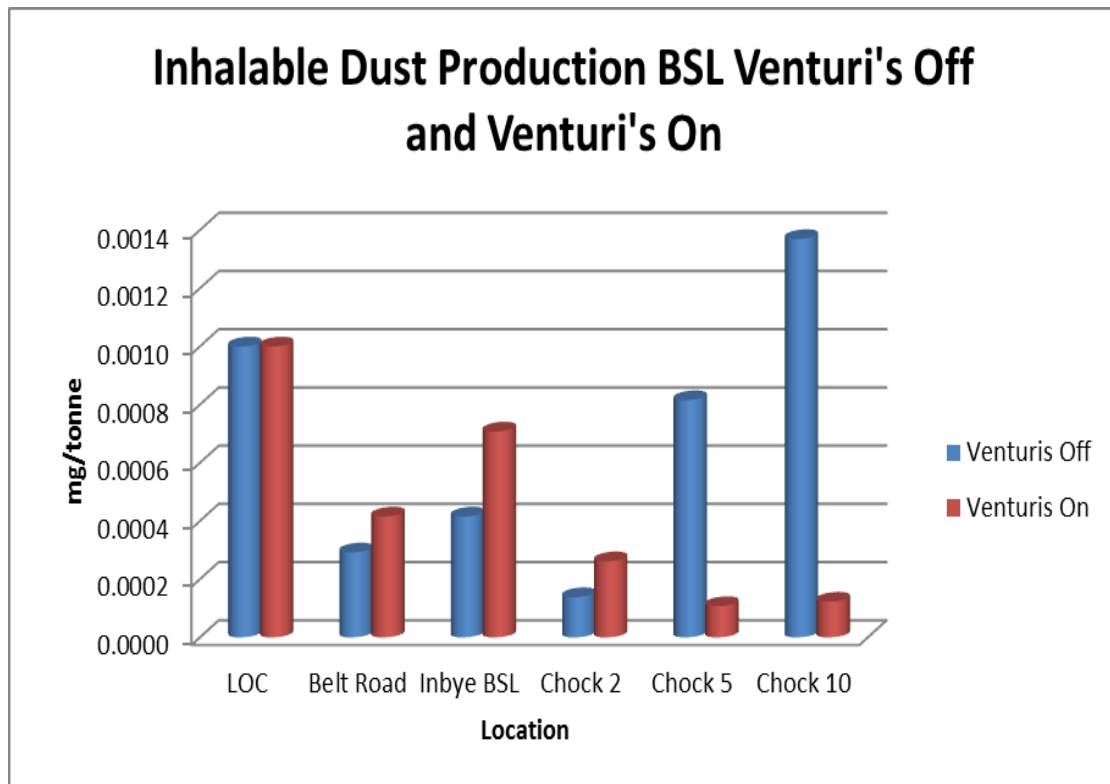
### **8.7.3 Respirable Dust Discussion**

DME results for this test were significantly different than CFD modelling had predicted. Predictions had shown that a *decrease* in respirable dust production would occur with the BSL venturi spray operating, particularly around the crusher discharge and chock #2. Actual results showed an *increase* in all respirable dust readings with the BSL venturi spray operating.

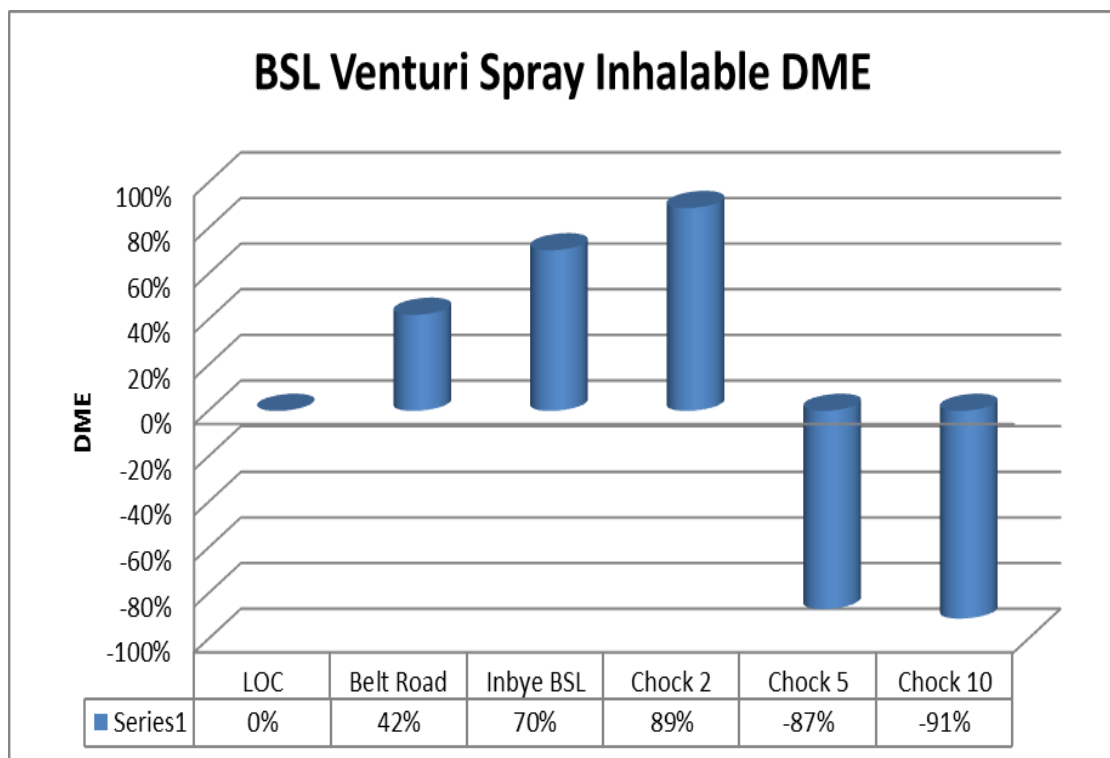
Further analysis of the longwall operating parameters found that there was 10m<sup>3</sup>/sec of air escaping into the goaf via the open area between the maingate chock and the rib. This happened due to the goaf curtain not being in position on the day of this test. The escaping air into the goaf created a low pressure system that drew air from as far down the face as chock #4, resulting in higher than expected readings. It was determined that this test would be retaken ensuring the goaf curtain was in place.

### **8.7.4 Inhalable Dust Analysis**

Figure 8.21 summarises the inhalable data collected for Mine B. Figure 8.23 summarises the inhalable DME for Mine B.



**Figure 8.22 Mine B, Test 6 Inhalable Dust Production**



**Figure 8.23 Mine B, Test 6 Inhalable DME**

### **8.7.5 Inhalable DME Discussion**

Inhalable results around the BSL area *increased* also due to contaminated air being drawn back to the maingate area. However, *decreases* at chock 5 and 10 were measured. Further analysis and retesting will determine if this decrease in inhalable dust was as a result of the venturi.

### **8.7.6 DME Conclusion**

Although this result was deemed a failure in the performance of the venturi sprays, it has shown that the DME model is robust enough to be sensitive to ventilation changes that will have a significant effect on the respirable and inhalable dust distribution on the longwall face.

## **8.8 Results Mine B Test 7 – Venturi Sprays, Test 2**

Mine B, Test 7 was a retest of the operational DME of a new venturi spray design located on the BSL as detailed in Test 6. The retest was necessary due to what was deemed a failure of Test 6 as a result of non-standard ventilation parameters that significantly affected the venturi performance.

### **8.8.1 Respirable and Inhalable Dust Raw Data**

Table 8.10 summarises the raw data collected for respirable and inhalable dust production for Mine B.



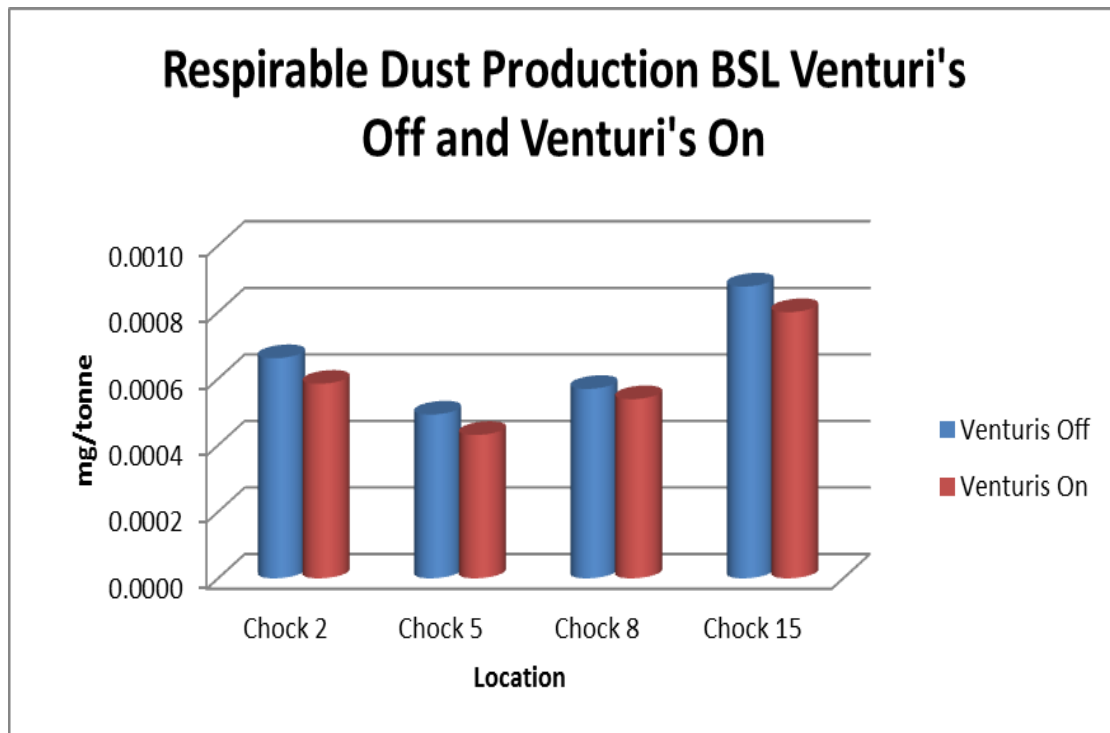
**CHAPTER EIGHT**  
Data Analysis and Discussion

**Table 8.10 Mine B, Test 7 Raw Data**

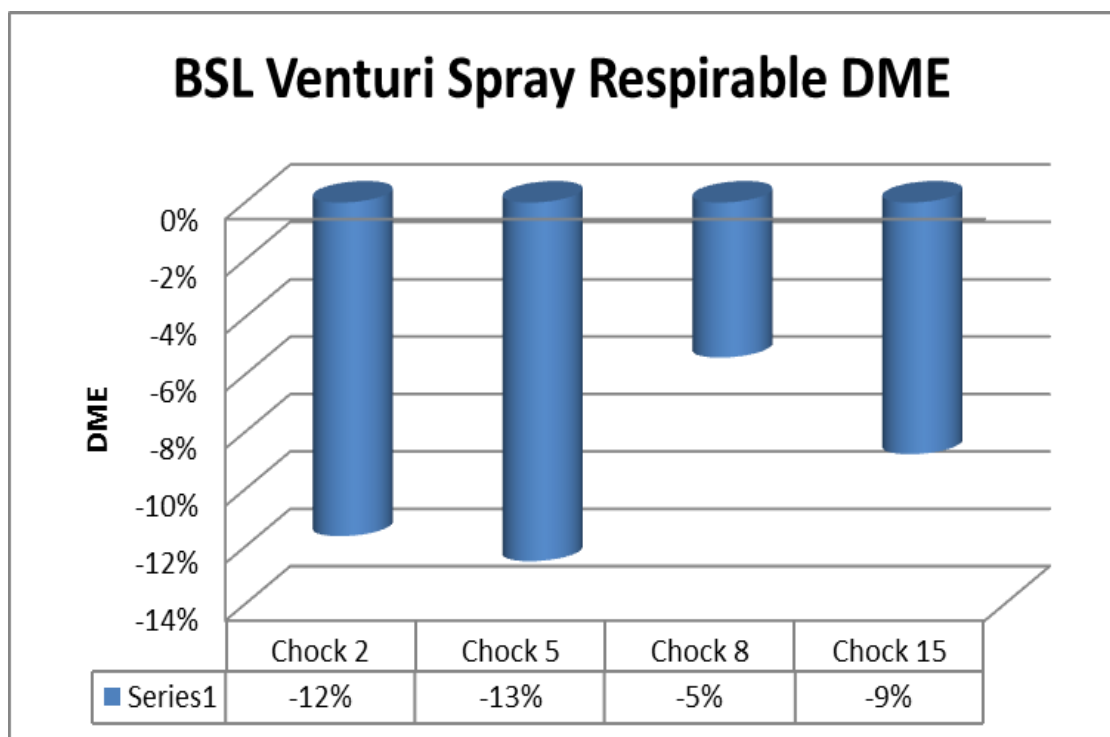
<u>Benchmark Test with BSL Venturi Sprays Operating</u>							
<u>Respirable Dust</u>							
Sample ID	Initial Weight	Final Weight	Net weight	Sample ID	Initial Weight	Final Weight	Net weight
Chock 2	6.34	6.77	0.43	2Chock 2	5.12	5.5	0.38
Chock 5	4.58	4.9	0.32	2Chock 5	5.67	5.95	0.28
Chock 8	6.08	6.45	0.37	Chock 8	5.55	5.9	0.35
Chock 15	5.94	6.51	0.57	2Chock 15	4.73	5.25	0.52
<u>Inhalable Dust</u>							
Sample ID	Initial Weight	Final Weight	Net weight	Sample ID	Initial Weight	Final Weight	Net weight
Chock 2	4.74	5.26	0.52	2Chock 2	4.89	5.35	0.46
Chock 5	5.77	6.11	0.34	2Chock 5	5.78	6.1	0.32
Chock 8	5.13	5.72	0.59	Chock 8	5.42	5.92	0.5
Chock 15	5.91	6.88	0.97	2Chock 15	5.28	6.45	1.17
Tonnes	650						

**8.8.2 Respirable Dust Analysis**

Figure 8.24 summarises the respirable data collected for Mine B. Figure 8.25 summarises the respirable DME for Mine B.



**Figure 8.24 Mine B, Test 7 Respirable Dust Production**



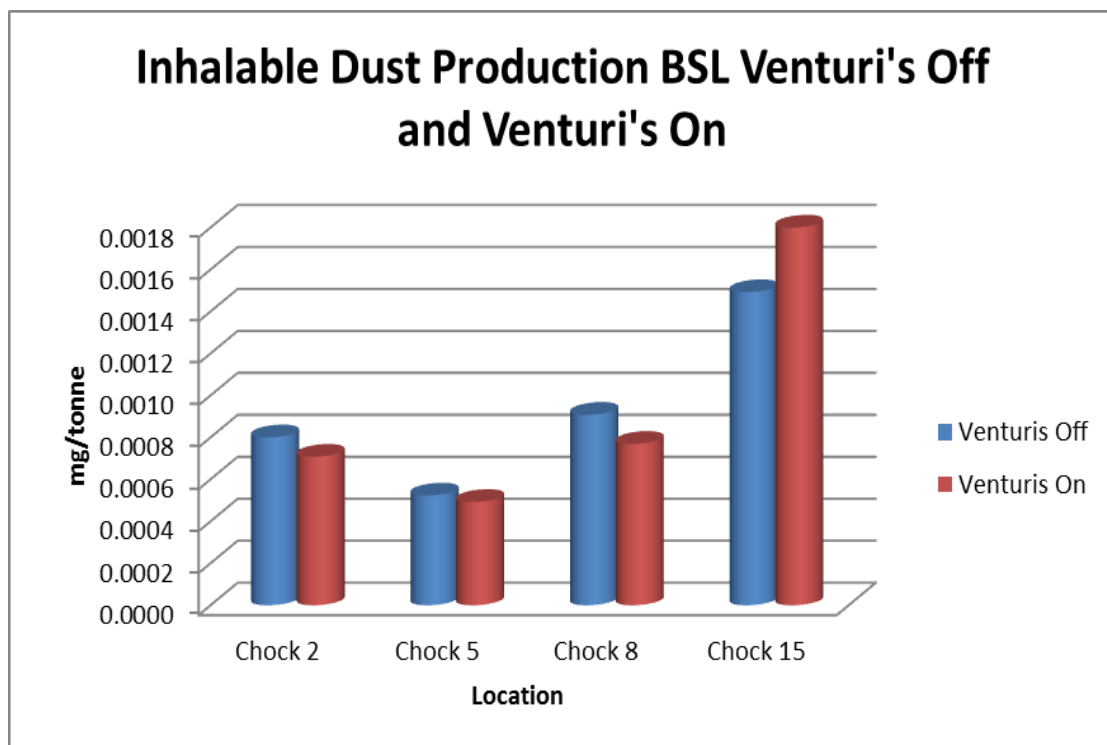
**Figure 8.25 Mine B, Test 7 Respirable DME**

### 8.8.3 Respirable Dust Discussion

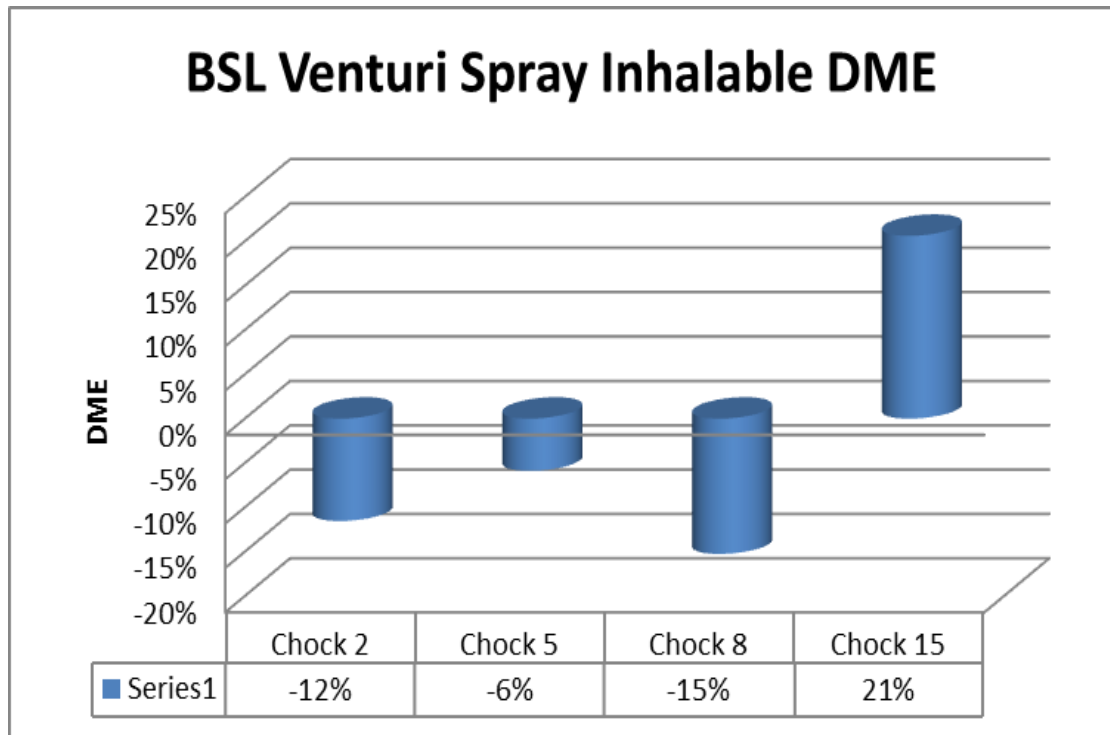
Mine B, Test 7 results show the BSL venturi has reduced the respirable dust production along the longwall face between 5 -13%. The most noticeable effect was seen at chocks #2 and #5 with *decreases* in respirable dust production of 12 and 13% respectively.

### 8.8.4 Inhalable Dust Analysis

Figure 8.26 summarises the inhalable data collected for Mine B. Figure 8.27 summarises the inhalable DME for Mine B.



**Figure 8.26 Mine B, Test 7 Inhalable Dust Production**



**Figure 8.27 Mine B, Test 7 Inhalable DME**

### 8.8.5 Inhalable DME Discussion

The inhalable dust production has also shown a *decrease* in inhalable dust production at chock #2 of 12%, chock #5 of 6%, chock #8 of 15% and an *increase* in inhalable dust production at chock #15 of 21%.

### 8.8.6 DME Conclusion

Mine B, Test 7 has shown that with the correct ventilation of 45m<sup>3</sup>/sec directed down the face, in contrast to bypassing the maingate into the goaf area as seen in Test 6 , the use of a single venturi operating at the BSL can have a significant decrease in both respirable and inhalable dust production during the cutting cycle.

### 8.9 Results Mine D Test 8

Mine D, Test 8 was performed to establish a respirable benchmark dust production only. No inhalable samples were taken as only 10 monitors were approved to take underground for the testing. The testing methodology used for this set of samples

required the establishment of a benchmark respirable dust production comparison with all controls operating. No testing was undertaken with the controls off.

### 8.9.1 Respirable Dust Raw Data

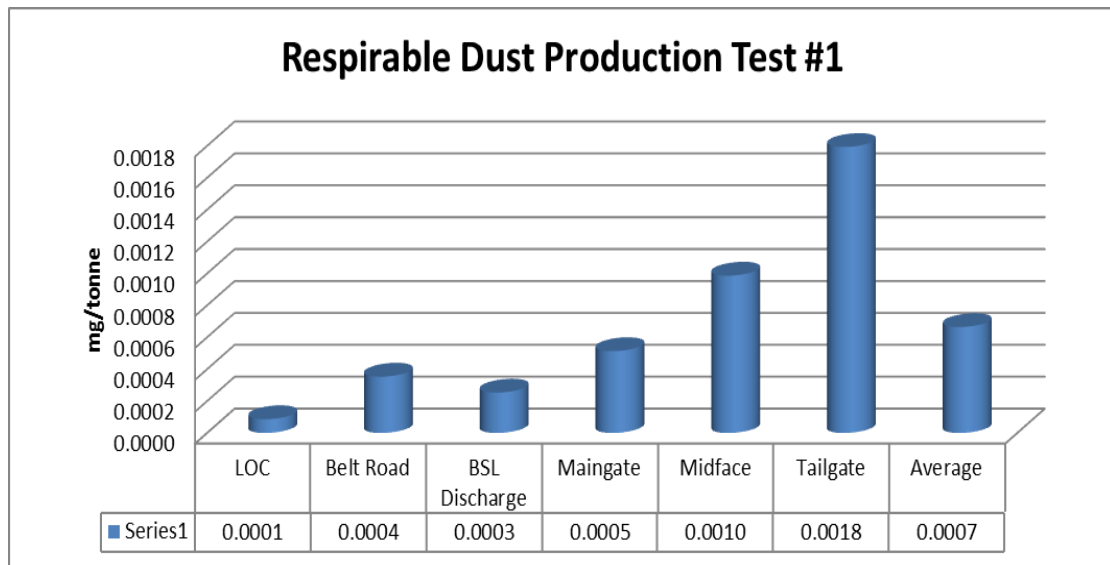
Table 8.11 summarise raw data collected from Mine D in the first benchmark test. These results were applied to the average dust load production of other samples operations and analysed as no further testing was undertaken.

**Table 8.11 Mine D, Test 8 Respirable Raw Data**

<b>Benchmark Test #1</b>			
<b>Respirable Dust Benchmark #1</b>			
<b>Sample ID</b>	<b>Initial Weight</b>	<b>Final Weight</b>	<b>Net weight</b>
LOC	6.47	6.6	0.13
Belt Road	6.27	6.8	0.53
BSL Discharge	5.86	6.04	0.18
Maingate	6.34	7.11	0.77
Midface	5.8	7.28	1.48
Tailgate	6	8.69	2.69
Tonnes Benchmark		1500	

### 8.9.2 Respirable Dust Production Test 1

Figure 8.28 summarises the respirable dust production at Mine D for the first benchmark test.



**Figure 8.28 Mine D, Test 8 Respirable Dust Production Benchmark #1**

### 8.9.3 Results Mine D Test 9

Mine D Test 9 was the second respirable dust load production test. This test was performed with the same operating parameters to Test 8.

### 8.9.4 Respirable Dust Raw Data

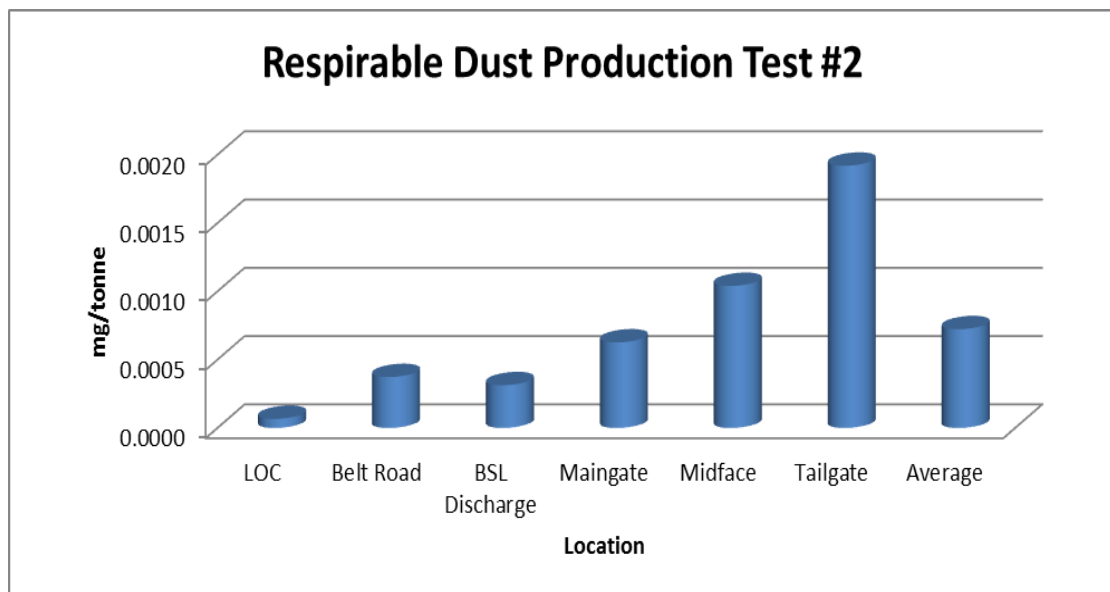
Table 8.12 summarise raw data collected from Mine D in the second benchmark test. These results were applied to the average dust load production of other samples operations and analysed as no further testing was undertaken.

**Table 8.12 Mine D, Test 9 Respirable Raw Data**

<b>Benchmark Test #2</b>			
<b>Respirable Dust Benchmark #2</b>			
<b>Sample ID</b>	<b>Initial Weight</b>	<b>Final Weight</b>	<b>Net weight</b>
LOC	6.3	6.4	0.1
Belt Road	6.65	7.21	0.56
BSL Discharge	6.54	7.01	0.47
Maingate	5.91	6.85	0.94
Midface	6.76	8.32	1.56
Tailgate	6.06	8.94	2.88
Tonnes Benchmark		1500	

### 8.9.5 Respirable Dust Production Test 2

Figure 8.29 summarises the respirable dust production at Mine D for the second benchmark test.

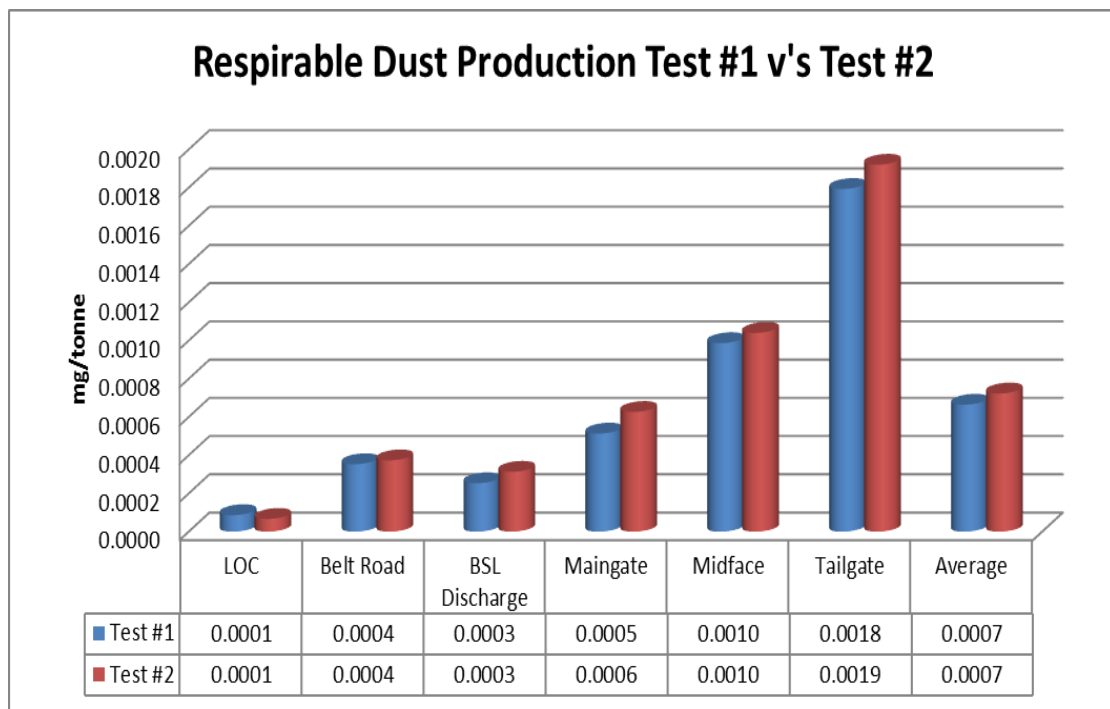


**Figure 8.29 Mine D, Test 9 Respirable Dust Production Benchmark #2**

### 8.9.6 Respirable Benchmark Dust Load Discussion

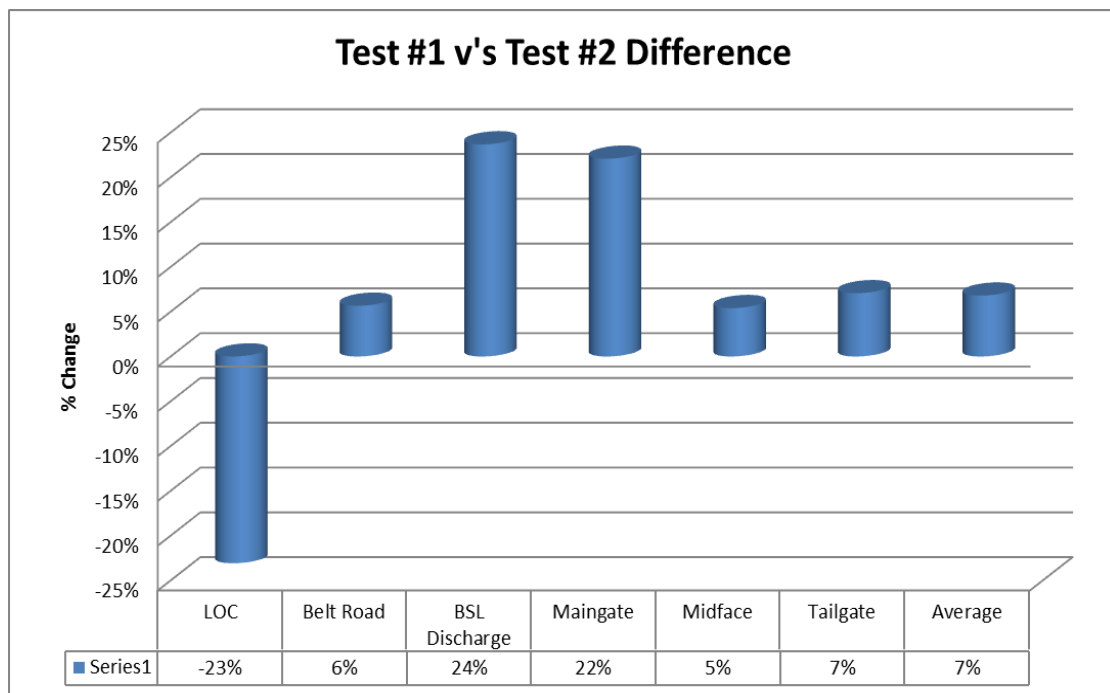
Figure 8.30 summarises the respirable dust production measured in test 1 and test 2.

**CHAPTER EIGHT**  
Data Analysis and Discussion



**Figure 8.30 Mine D, Test 8 & 9 Respirable Benchmark Comparison**

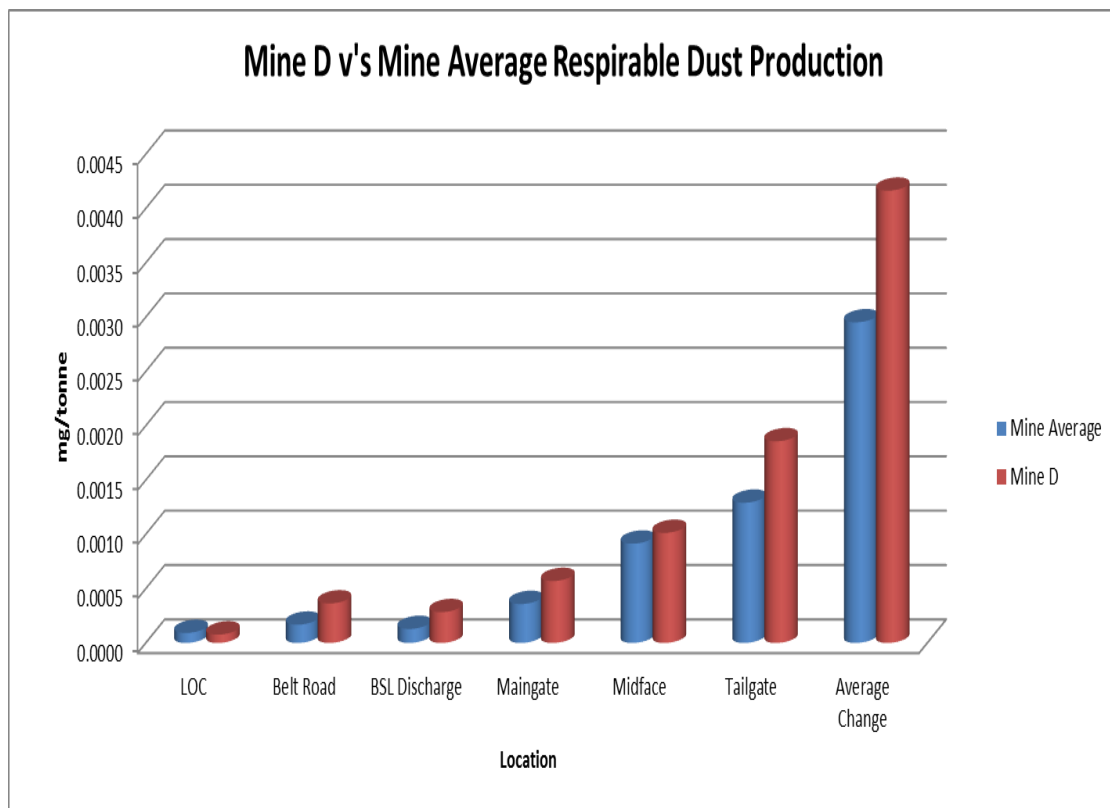
Figure 8.31 details the difference in respirable dust production between the two tests.



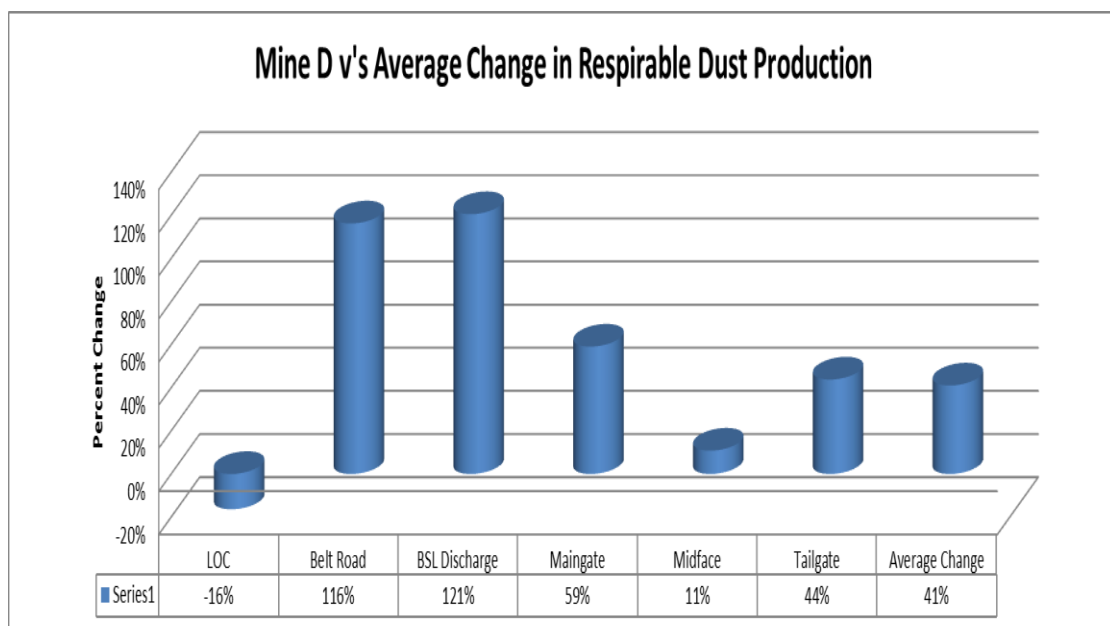
**Figure 8.31 Mine D, Test 8 & 9 Benchmark Dust Load Difference**

Figure 8.32 details the respirable dust production of Mine D to the average respirable dust production of previous tests.





**Figure 8.32 Mine D Average Respirable Dust Production Comparison**



**Figure 8.33 Mine D Average Respirable Dust Production Comparison**

### 8.9.7 Average Respirable Dust Load Discussion

Mine D has shown that it produces 41% more respirable dust per tonne of coal cut than the average of all the other mines tested. No inhalable samples were collected,

but it can be assumed that these results would also push toward 50% more than other mines. Further analysis will need to be undertaken to establish why this increase in dust loads is so significant.

The DME model has shown versatility and adaptability as well as robustness in being able to quantify mine average dust production performance comparisons. This information will give mine operators sound information on how well their installed controls are doing in comparison to the industry average of other mines tested. This information will allow mine operators to install engineering controls that have been proven to mitigate more dust than those currently installed.

### **8.10 Results Mine B Test 10 – Venturi Sprays Test 3**

Mine B, Test 10 was a continuation of the new design venturi testing. Test 10 was undertaken to quantify the DME of the new design venturi system with multiple venturis placed on chock #6. Samples were placed in the same locations as Test 7. As in previous tests detailed in this chapter, comprehensive CFD modelling was undertaken and the DME model was being used to quantify those results.

#### **8.10.1 Respirable and Inhalable Dust Raw Data**

Table 8.13 summarises the raw data collected for respirable and inhalable dust production for Mine B.

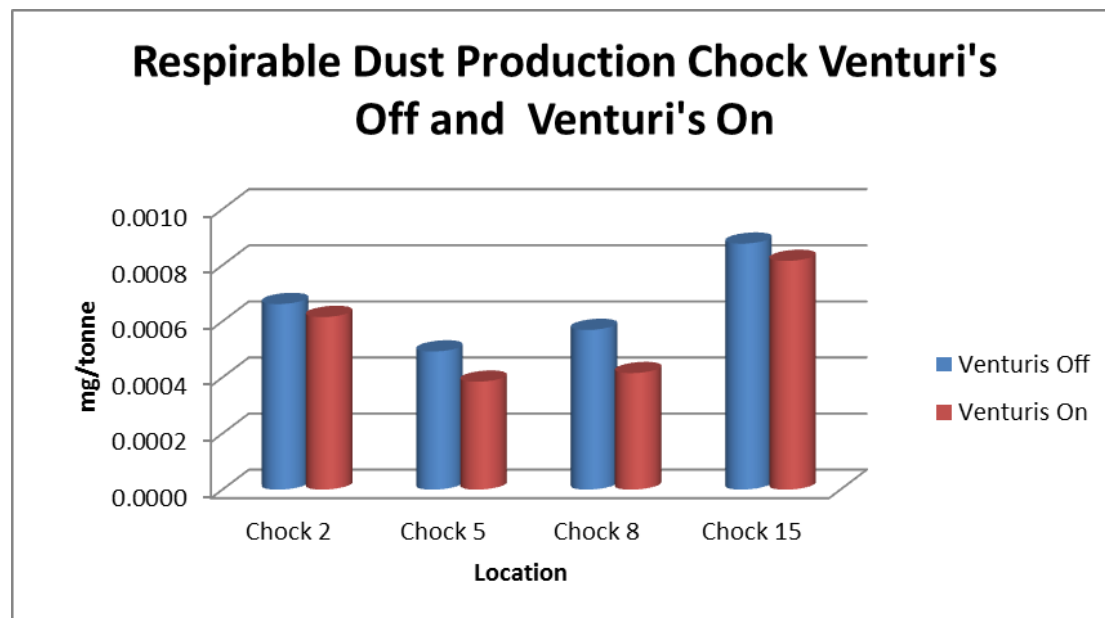
**CHAPTER EIGHT**  
Data Analysis and Discussion

**Table 8.13 Mine B, Test 10 Raw Data**

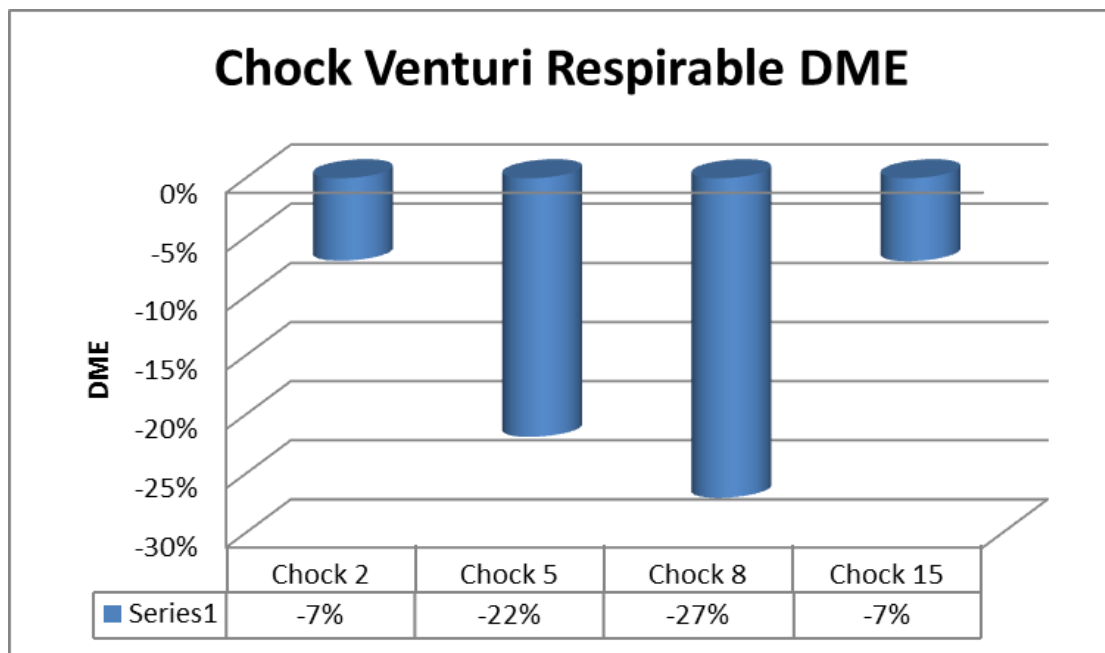
<u>Benchmark Test with Chock #6 Venturi Sprays Operating</u>							
<b>Respirable Dust</b>							
Sample ID	Initial Weight	Final Weight	Net weight	Sample ID	Initial Weight	Final Weight	Net weight
Chock 2	6.34	6.77	0.43	3Chock 2	4.5	4.9	0.4
Chock 5	4.58	4.9	0.32	3Chock 5	4.87	5.12	0.25
Chock 8	6.08	6.45	0.37	Chock 8	5.9	6.17	0.27
Chock 15	5.94	6.51	0.57	3Chock 15	6.7	7.23	0.53
<b>Inhalable Dust</b>							
Sample ID	Initial Weight	Final Weight	Net weight	Sample ID	Initial Weight	Final Weight	Net weight
Chock 2	4.74	5.26	0.52	3Chock 2	5.16	5.65	0.49
Chock 5	5.77	6.11	0.34	3Chock 5	5.92	6.2	0.28
Chock 8	5.13	5.72	0.59	Chock 8	6.49	7.05	0.56
Chock 15	5.91	6.88	0.97	3Chock 15	6.07	6.22	0.15
Tonnes	650						

**8.10.2 Respirable Dust Analysis**

Figure 8.34 summarises the respirable data collected for Mine B. Figure 8.35 summarises the respirable DME for Mine B.



**Figure 8.34 Mine B, Test 10 Respirable Dust Production**



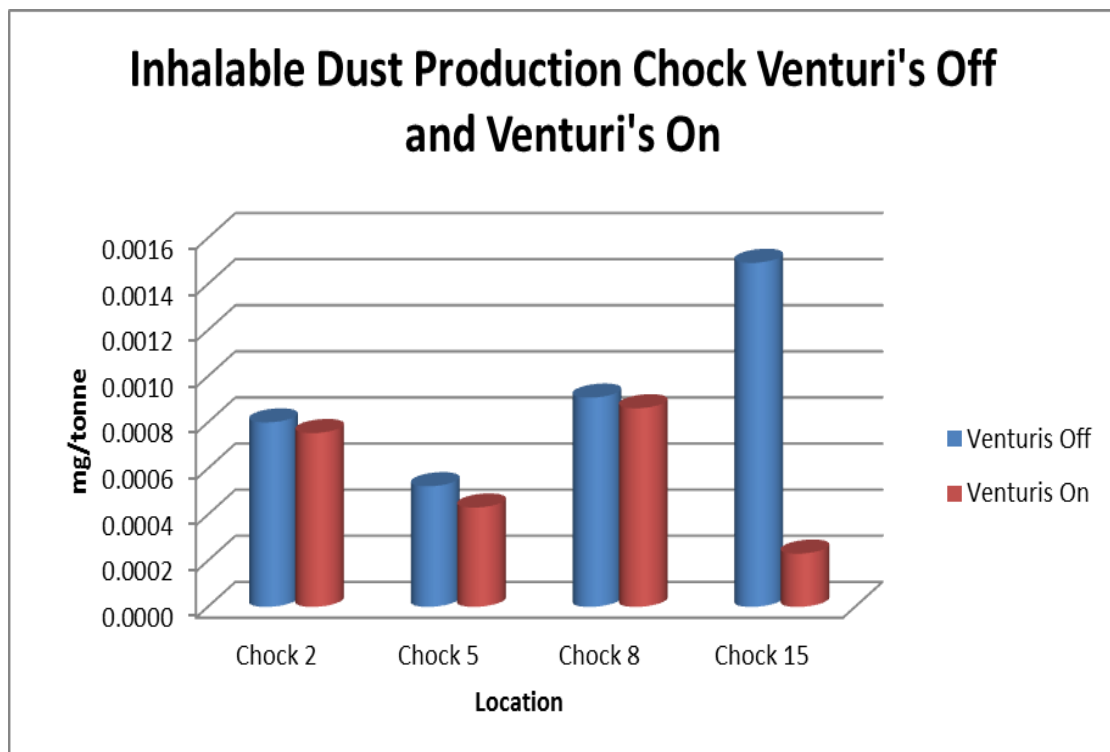
**Figure 8.35 Mine B, Test 10 Respirable DME**

### **8.10.3 Respirable DME Discussion**

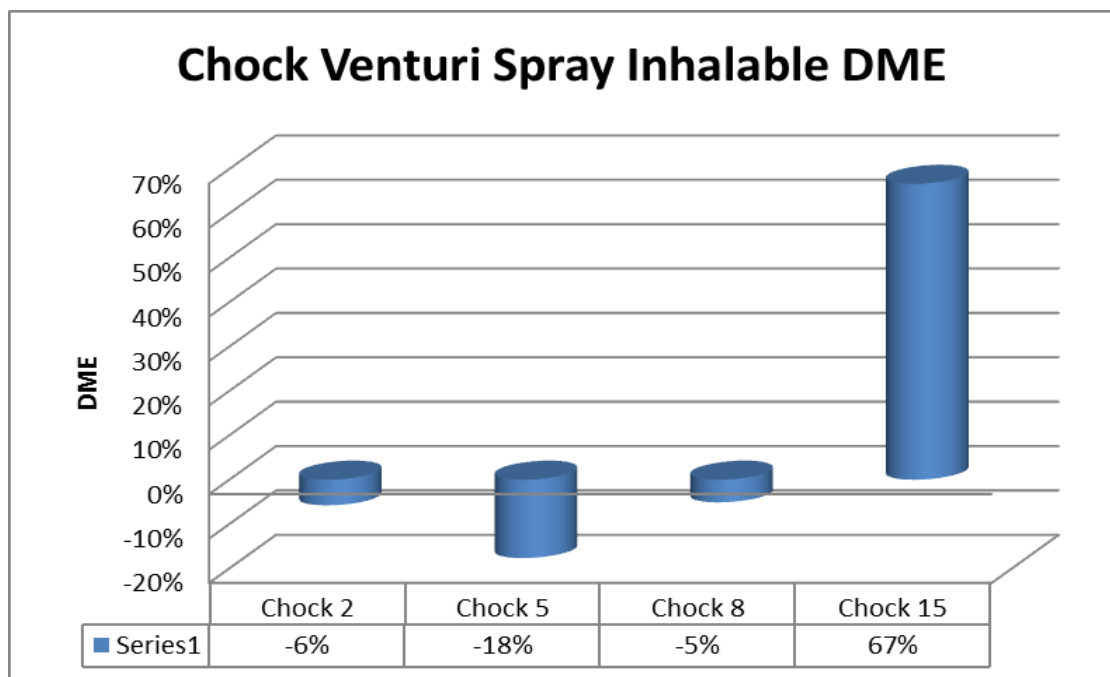
The chock venturis showed a *decrease* of respirable dust by 7% at chock #2, 22% at chock #5, 27% at chock #8 and 7% at chock #15. The results indicate that the venturis have a significant effect by mitigating the respirable dust from entering the atmosphere.

### **8.10.4 Inhalable Dust Analysis**

Figure 8.36 summarises the inhalable data collected for Mine B. Figure 8.37 summarises the inhalable DME for Mine B.



**Figure 8.36 Mine B, Test 10 Inhalable Dust Production**



**Figure 8.37 Mine B, Test 10 Inhalable DME**

### 8.10.5 Inhalable DME Discussion

The corresponding inhalable results show a *decrease* at chock #2 of 6%, chock #5 of 18%, chock #8 of 5% but an *increase* of 67% at chock #15. The reduction found up to

chock #8 indicates that the venturis are effective at knocking down inhalable dust. The increase in chock # 15 inhalable dust can be attributed to chock movement.

### **8.10.6 DME Conclusion**

Both the BSL venturi and the chock venturis have a significant effect on removing respirable and inhalable dust up to chock 15 in this instance. By turning on both the BSL and chock venturis whilst the maingate chocks are moving, up to 35% of the respirable dust will be removed from the atmosphere.

Field trials demonstrated that the design of the water mist based venturi unit is robust and simple to use in underground longwalls for dust mitigation, however the issue of wetting by water mist travelling along the face has been raised. This problem can be minimised by positioning the units further in front under the canopy or by turning off the units once the advance of the 1-5 MG chocks is completed.

## **8.11 Results Mine B Test 11 – Surfactant Testing**

Mine B, Test 11 was performed to quantify the DME of Compliance 2000 surfactant injected into the spray system for the longwall and shearer. Samples were located and collected as per Mine B, Test 2. The benchmark test was conducted with all sprays operating and no Compliance 2000 injected into the water and the efficiency test was conducted with Compliance 2000 injected.

### **8.11.1 Respirable and Inhalable Dust Raw Data**

Table 8.14 summarises the raw data collected for respirable and inhalable dust production at Mine B.

## CHAPTER EIGHT

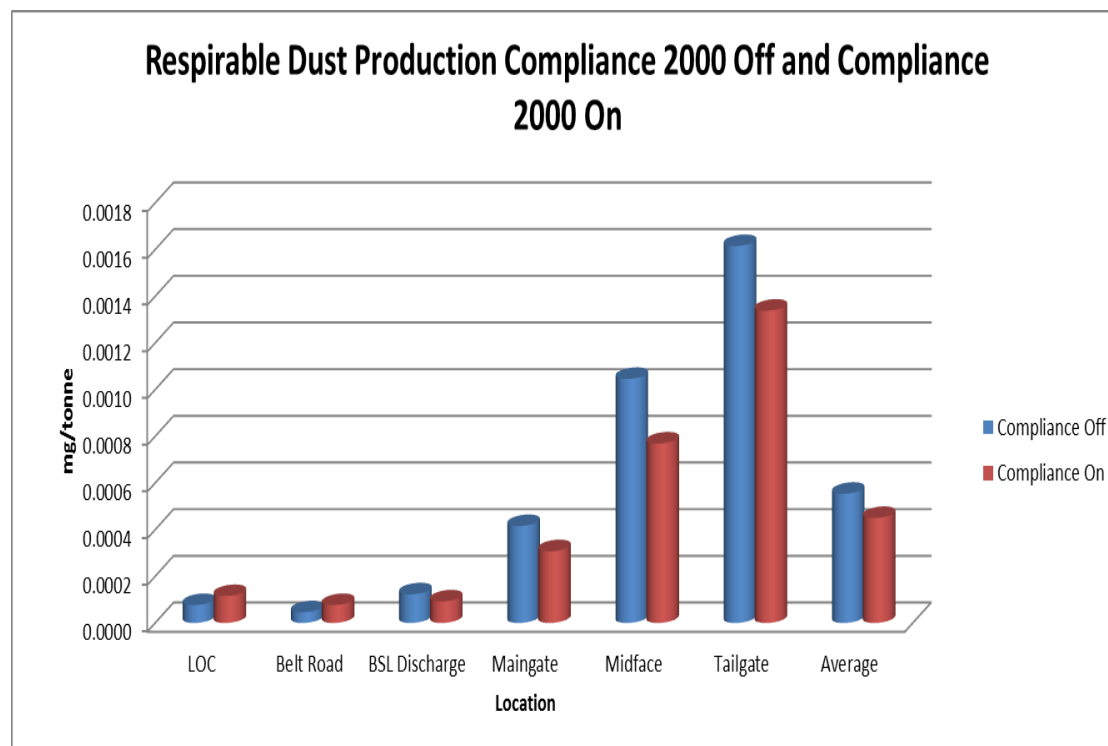
### Data Analysis and Discussion

**Table 8.14 Mine B, Test 11 Raw Data**

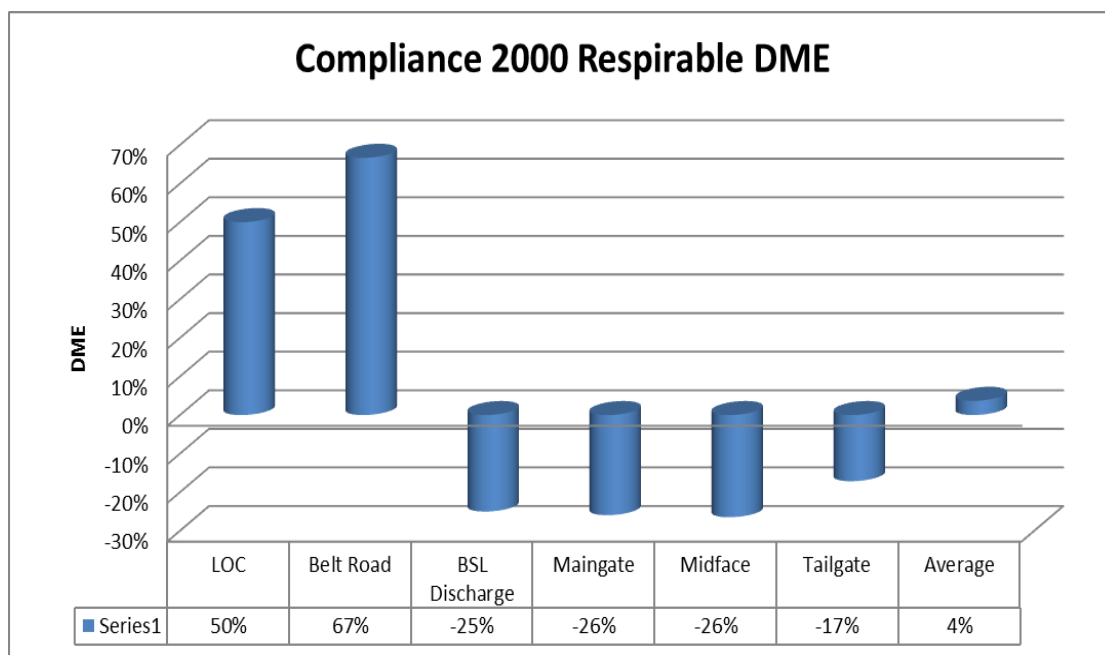
Compliance 2000 Efficiency Testing							
<u>Respirable Dust Benchmark</u>				<u>Respirable Dust Compliance 2000 Operating</u>			
Sample ID	Initial Weight	Final Weight	Net weight	Sample ID	Initial Weight	Final Weight	Net weight
LOC	6.16	6.21	0.05	LOC	5.89	6.04	0.15
Belt Road	6.65	6.68	0.03	Belt Road	6.42	6.52	0.1
BSL Discharge	6.54	6.62	0.08	BSL Discharge	6.01	6.13	0.12
Maingate	6.26	6.53	0.27	Maingate	6.54	6.74	0.2
Midface	7.87	8.55	0.68	Midface	6.44	6.94	0.5
Tailgate	7.8	8.85	1.05	Tailgate	6.16	7.03	0.87
<u>Inhalable Dust Benchmark</u>				<u>Inhalable Dust Compliance 2000 Operating</u>			
Sample ID	Initial Weight	Final Weight	Net weight	Sample ID	Initial Weight	Final Weight	Net weight
LOC	5.82	5.97	0.15	LOC	5.8	6.12	0.32
Belt Road	7.62	7.81	0.19	Belt Road	6.43	6.85	0.42
BSL Discharge	7.84	8.03	0.19	BSL Discharge	6.03	6.5	0.47
Maingate	7.68	8.1	0.42	Maingate	6.39	6.86	0.47
Midface	7.65	8.25	0.6	Midface	6	6.82	0.82
Tailgate	7.64	8.45	0.81	Tailgate	6.42	7.33	0.91
Tonnes Benchmark		650					
Tonnes Compliance 2000 on O/B		1300					
Tonnes Compliance 2000 on I/B		650					

### 8.11.2 Respirable Dust Analysis

Figure 8.38 summarises the respirable data collected for Mine B. Figure 8.39 summarises the respirable DME for Mine B.



**Figure 8.38 Mine B, Test 11 Respirable Dust Production**



**Figure 8.39 Mine B, Test 11 Respirable DME**

### 8.11.3 Respirable DME Discussion

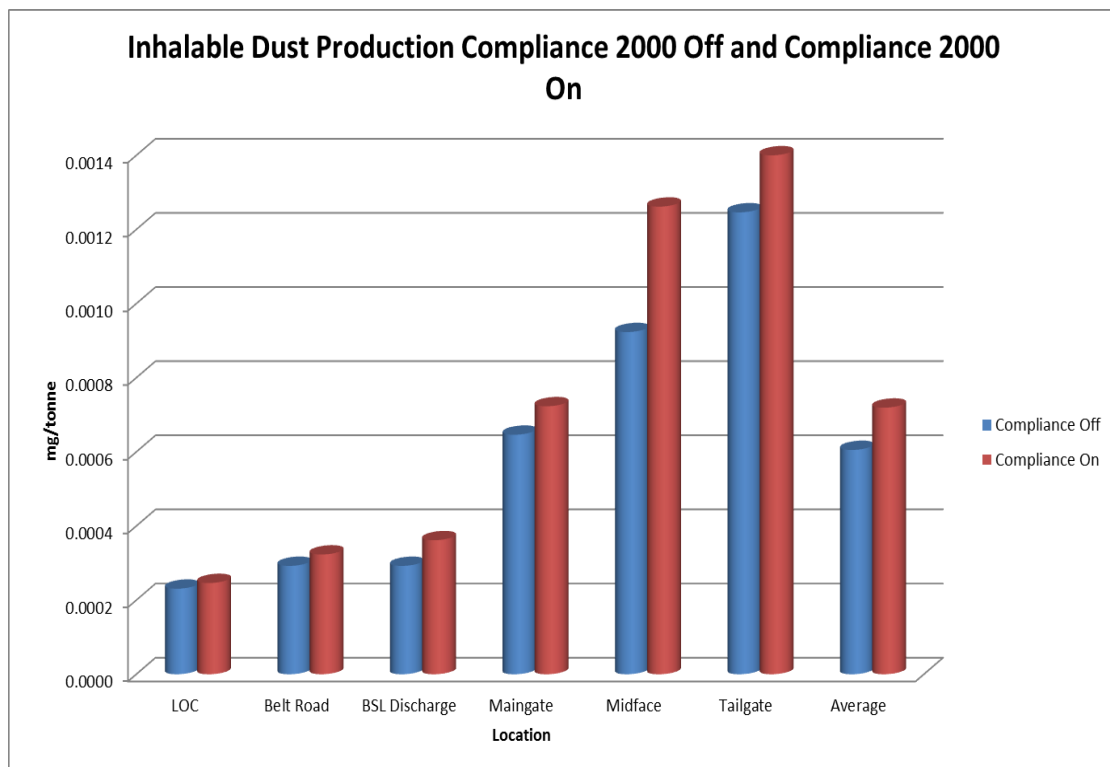
The average DME for respirable dust increased by 4% with Compliance 2000 injected. Compliance 2000 showed a *decrease* in respirable dust production at the BSL discharge of 25%, the maingate of 26%, midface of 26% and the tailgate of 17%. The LOC and belt road both showed an *increase* in respirable dust production of 50% and 67% respectively. These results may indicate an increase in an outbye activity or vehicle movements. This needs to be retested to quantify dust loads which should see a reduction in the outbye dust which will result in Compliance 2000 having a positive mitigation effect on the respirable dust.

### 8.11.4 Inhalable Dust Analysis

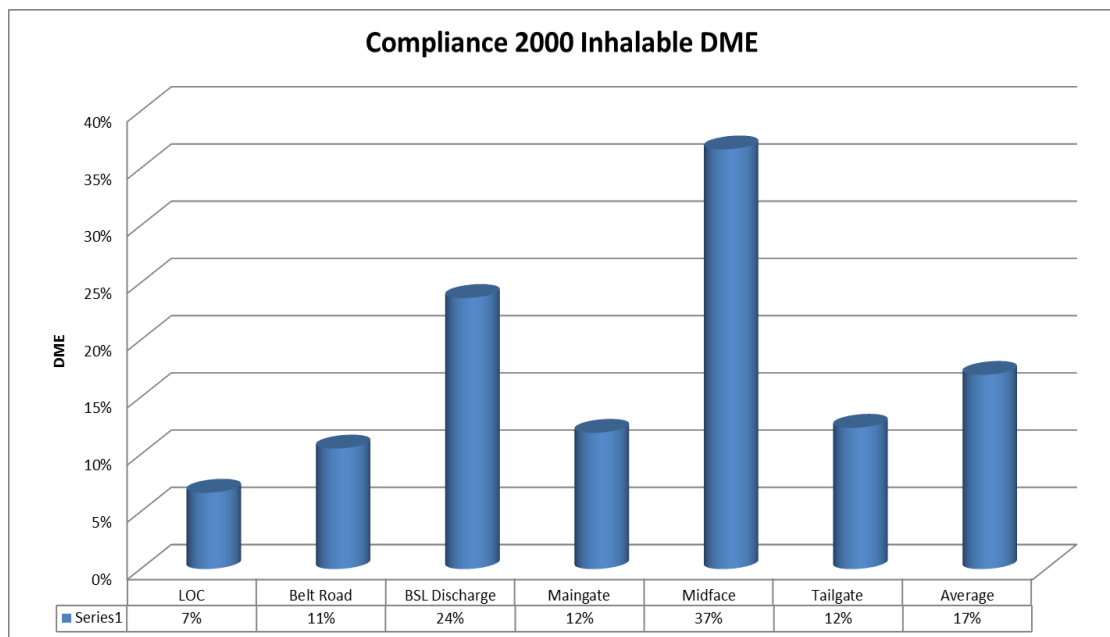
Figure 8.40 summarises the inhalable data collected for Mine B. Figure 8.41 summarises the inhalable DME for Mine B.



**CHAPTER EIGHT**  
Data Analysis and Discussion



**Figure 8.40 Mine B, Test 11 Inhalable Dust Production**



**Figure 8.41 Mine B, Test 11 Inhalable DME**

**8.11.5 Inhalable DME Discussion**

All inhalable samples *increased* between 7% and 37% with the introduction of the Compliance 2000.

### **8.11.6 DME Conclusion**

Compliance 2000 has a positive result in removing respirable dust on the longwall face. However, the surfactant has a significant negative effect on the inhalable size dust fraction. LOC and Belt Road results need further investigation to determine what outbye activities or processes led to the increase in dust loads from Compliance off to Compliance on.

The Compliance 2000 usage rate has been calculated at approximately 0.729 litres for the 1 shear test. Actual dilution ratios will need to be calculated from obtaining the known water flow rate at the point of injection. Further efficiency gains may be made by increasing dilution rates of the Compliance 2000 and will need to be tested to quantify results.

## **8.12 Results Mine E Test 12**

Mine E was the fifth mine tested and using equipment purchased by the University of Wollongong. The equipment used is detailed in chapter 6, section 6.4.1. Respirable and inhalable dust loads were taken. Further samples were taken at Mine E and these are discussed later in this chapter.

### **8.12.1 Respirable and Inhalable Dust Raw Data**

Table 8.15 summarises the raw data collected for respirable and inhalable dust production at Mine E.

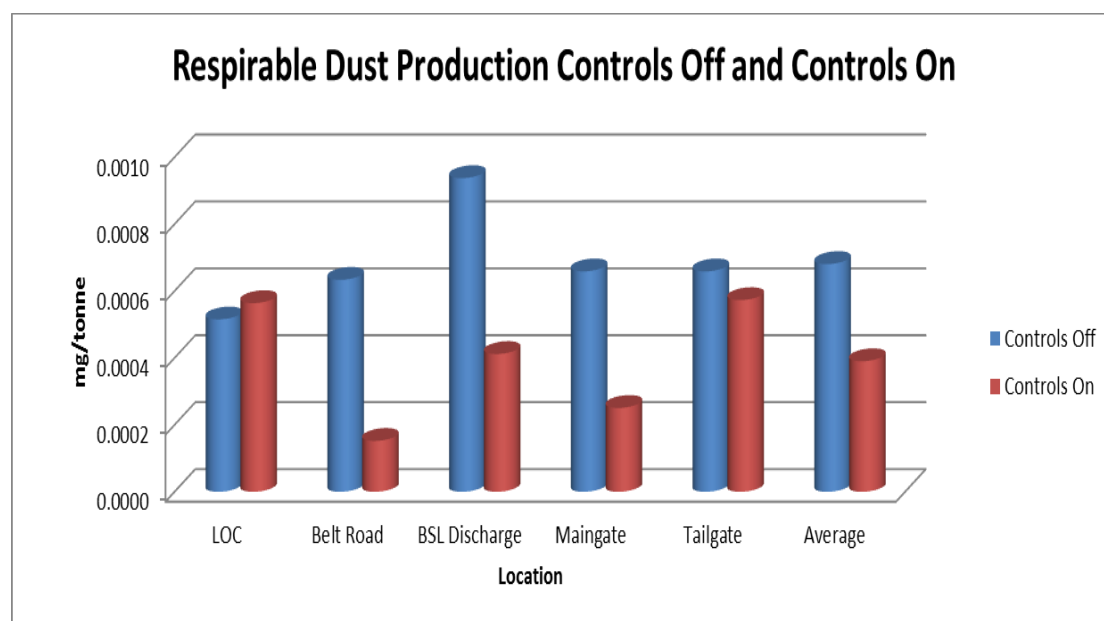
**CHAPTER EIGHT**  
Data Analysis and Discussion

**Table 8.15 Mine E, Test 12 Raw Data**

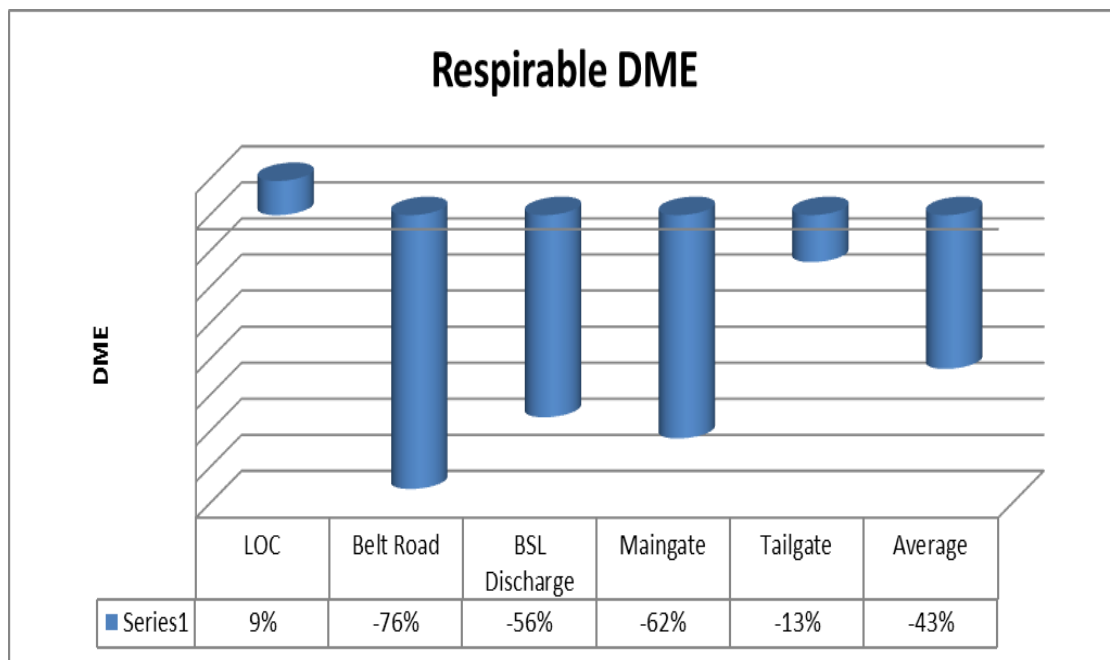
<u>Benchmark Test</u>							
<u>Respirable Dust Benchmark</u>				<u>Respirable Dust Controls Operating</u>			
Sample ID	Initial Weight	Final Weight	Net weight	Sample ID	Initial Weight	Final Weight	Net weight
LOC	7.08	7.69	0.61	LOC	7.34	7.97	0.63
Belt Road	7.02	7.77	0.75	Belt Road	7.13	7.3	0.17
BSL Discharge	6.97	8.08	1.11	BSL Discharge	7.54	8	0.46
Maingate	7.18	7.96	0.78	Maingate	7.71	7.99	0.28
Tailgate	7.11	7.89	0.78	Tailgate	7.54	8.18	0.64
<u>Inhalable Dust Benchmark</u>				<u>Inhalable Dust Controls Operating</u>			
Sample ID	Initial Weight	Final Weight	Net weight	Sample ID	Initial Weight	Final Weight	Net weight
LOC	7.3	7.89	0.59	LOC	7.54	8.06	0.52
Belt Road	7.2	7.73	0.53	Belt Road	7.45	7.62	0.17
BSL Discharge	7.51	7.66	0.15	BSL Discharge	7.44	8.1	0.66
Maingate	7.94	8.18	0.24	Maingate	7.3	8.16	0.86
Tailgate	7.48	8.14	0.66	Tailgate	7.21	8.2	0.99
Tonnes Benchmark		1184		Tonnes Controls on		1117	

**8.12.2 Respirable Dust Analysis**

Figure 8.42 summarises the respirable data collected for Mine E. Figure 8.43 summarises the respirable DME for Mine E.



**Figure 8.42 Mine E, Test 12 Respirable Dust Production**



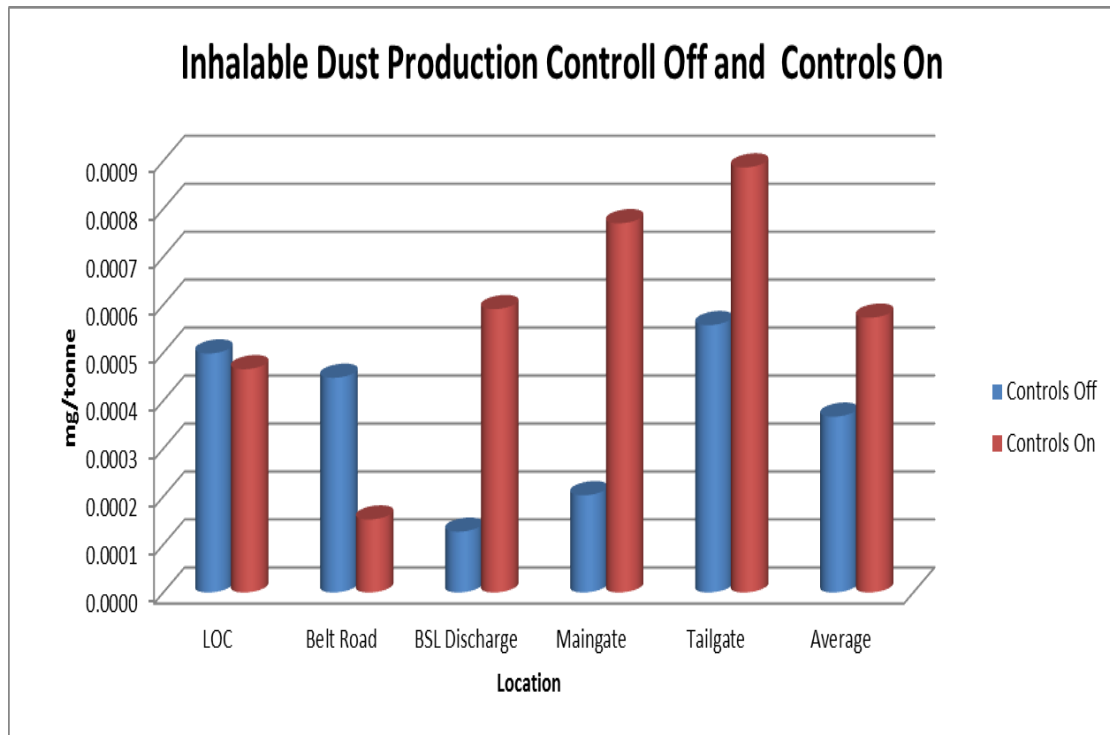
**Figure 8.43 Mine E, Test 12 Respirable DME**

### 8.12.3 Respirable DME Discussion

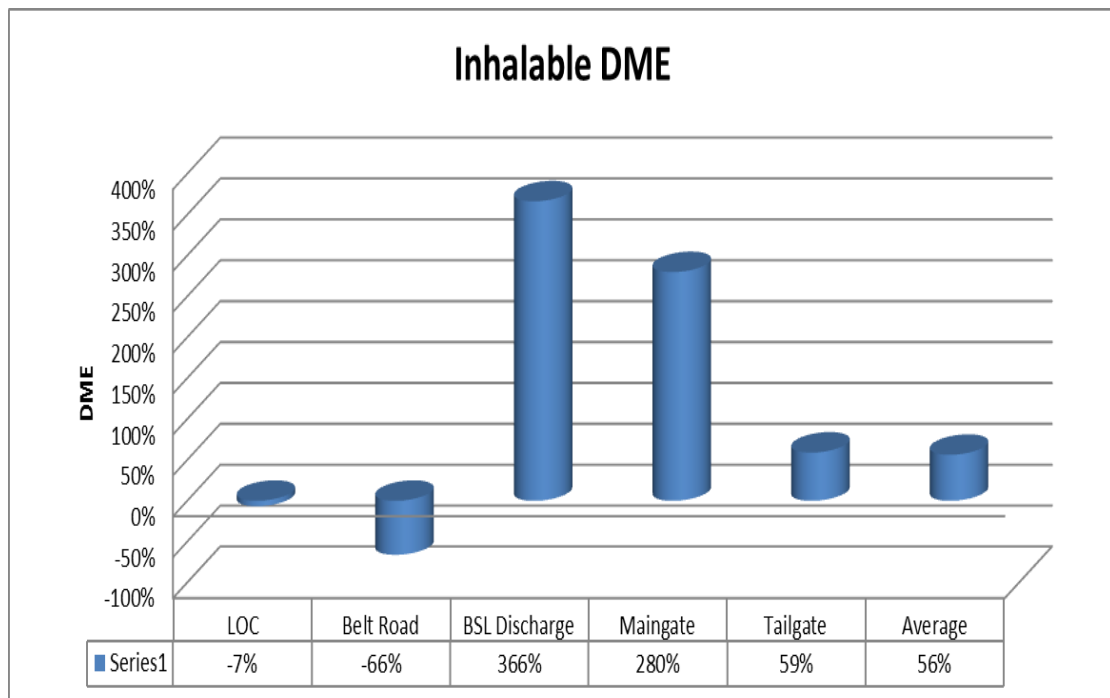
The LOC showed a 9% *increase* in respirable dust, whilst the belt road, BSL discharge, Maingate and tailgate experienced *decreases* of respirable dust of 76%, 56%, 62% and 13% respectively. This may indicate an outbye activity or vehicle movement that has contributed to the increase.

### 8.12.4 Inhalable Dust Analysis

Figure 8.44 summarises the inhalable data collected for Mine E. Figure 8.45 summarises the inhalable DME for Mine E.



**Figure 8.44 Mine E, Test 12 Inhalable Dust Production**



**Figure 8.45 Mine E, Test 12 Inhalable DME**

### 8.12.5 Inhalable DME Discussion

The LOC showed a *decrease* of 7% in inhalable dust with the belt road also *decreasing* by 66%. The BSL discharge showed an *increase* in inhalable dust of

366%. This will need to be retested as the result is quite significant, with further testing to either show the same result less. The main gate and tailgate also measured significant increase in inhalable dust with the controls operating of 280% and 59% respectively. If the second set of tests produces the same high result, urgent action will need to be implemented to ensure such significant increases are mitigated.

### **8.12.6 Average DME Discussion**

The testing results showed that the current installed controls *reduce* the amount of respirable dust by an average of 43%; however, the amount of inhalable dust showed an *increase* by an average of 56%. This would indicate that the installed controls are working well to mitigate respirable dust, but are increasing the amount of inhalable dust liberated into the atmosphere. Although the health risk to workers is slightly less for inhalable exposure, the dust loads will almost certainly result in failures during statutory testing.

### **8.12.7 DME Conclusion**

These results indicate that the current installed controls are mitigating respirable dust extremely well, however, inhalable dust control will require further and more comprehensive engineering controls to ensure future compliance and minimise exposure to employees.

This initial test indicates that if a statutory test were to have been performed in parallel with this benchmark test, Mine E would have passed the respirable exposure levels but failed the inhalable exposure levels. It is understood that this has been the case in recent tests.

## **8.13 Results Mine C Test 13 – Coal Services Scrubber**

Mine C installed a new T8E electric BSL scrubber on their new longwall. This unit replaces the original hydraulic scrubber that had been in operation for some years and was previously tested as part of a dust control efficiency test as shown in 8.3. The new

**CHAPTER EIGHT**  
Data Analysis and Discussion

design incorporates an intake duct on the outbye side of the DCB and a discharge hood back into the slope pans of the gooseneck.

Mine C, Test 13 was undertaken by Coal Services to quantify the DME of the new installed BSL scrubber. The testing was requested by the mine to independently measure the amount of respirable and inhalable dust removed by the scrubber from the BSL discharge and the maingate. The benchmark test was performed with all controls operating and the scrubber off and the efficiency test was undertaken with all controls and the scrubber operating. Data collection was as per the new testing methodology with Coal Services supplying all equipment and heads as per their standard testing methodology.

**8.13.1 Respirable and Inhalable Dust Raw Data**

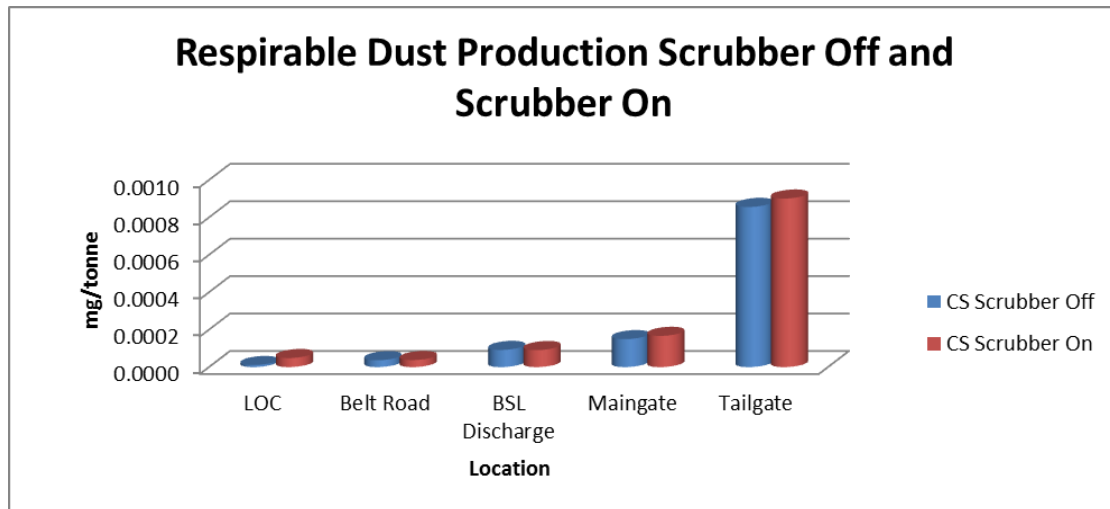
Table 8.16 summarises the raw data collected for respirable and inhalable dust production at Mine C.

**Table 8.16 Mine C, Test 13 Coal Services Scrubber Testing**

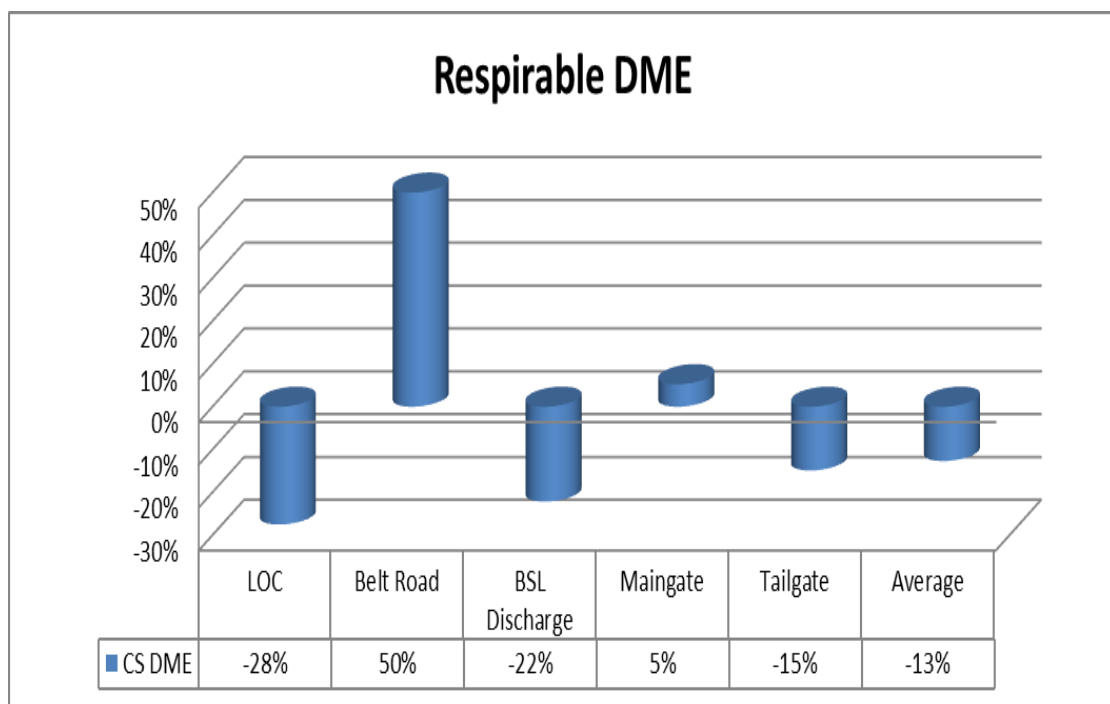
<u>Coal Services Efficiency Results</u>							
<u>Respirable Dust Benchmark - No Scrubber</u>				<u>Respirable Dust Scrubber Operating</u>			
Sample ID	Initial Weight	Final Weight	Net weight	Sample ID	Initial Weight	Final Weight	Net weight
LOC	7.13	7.21	0.013	LOC	7.42	7.47	0.058
Belt Road	7.22	7.25	0.044	Belt Road	7.27	7.32	0.045
BSL Discharge	7.23	7.37	0.11	BSL Discharge	7.17	7.29	0.109
Maingate	7.38	7.57	0.179	Maingate	7.46	7.65	0.2
Tailgate	7.38	8.65	1.027	Tailgate	7.11	8.01	1.081
<u>Inhalable Dust Benchmark - No Scrubber</u>				<u>Inhalable Dust Scrubber Operating</u>			
Sample ID	Initial Weight	Final Weight	Net weight	Sample ID	Initial Weight	Final Weight	Net weight
LOC	7.78	7.83	0.047	LOC	7.31	7.41	0.176
Belt Road	7.77	7.81	0.057	Belt Road	7.18	7.29	0.104
BSL Discharge	8.05	8.72	0.626	BSL Discharge	7.17	7.71	0.437
Maingate	7.16	7.65	0.864	Maingate	7.25	7.86	0.479
Tailgate	7.02	10.33	3.769	Tailgate	8	4.59	3.415
Tonnes Benchmark		1200					
Tonnes Efficiency		1200					

**8.13.2 Respirable Dust Analysis**

Figure 8.46 summarises the respirable data collected for Mine C. Figure 8.47 summarises the respirable DME for Mine C.



**Figure 8.46 Mine C, Test 13 Respirable Dust Production**



**Figure 8.47 Mine C, Test 13 Respirable DME**

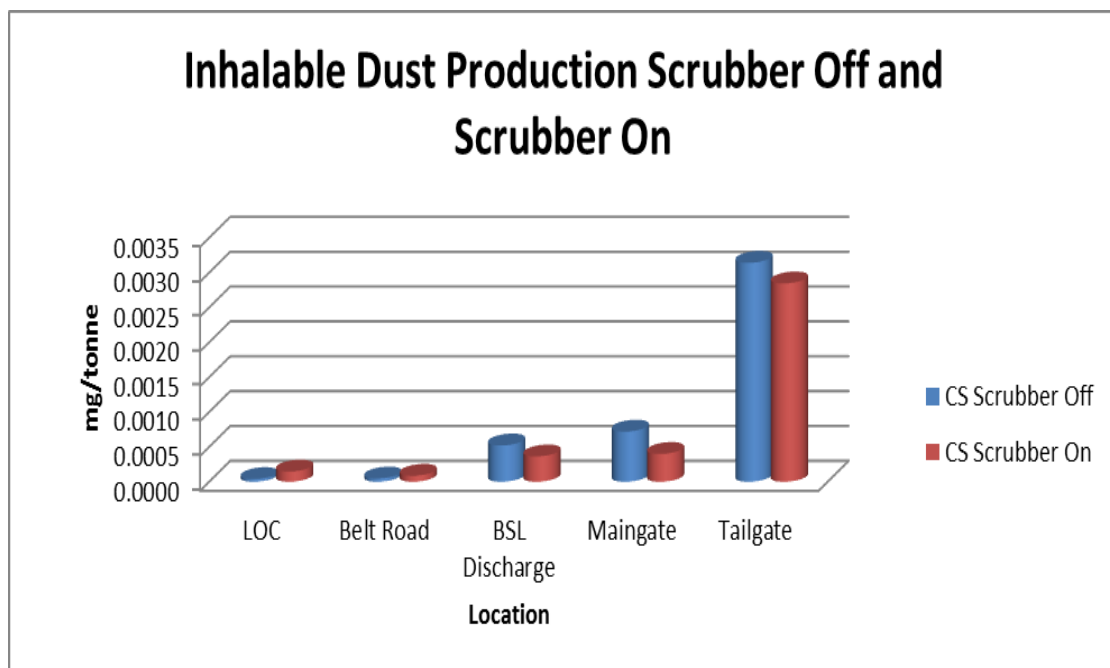


### 8.13.3 Respirable DME Discussion

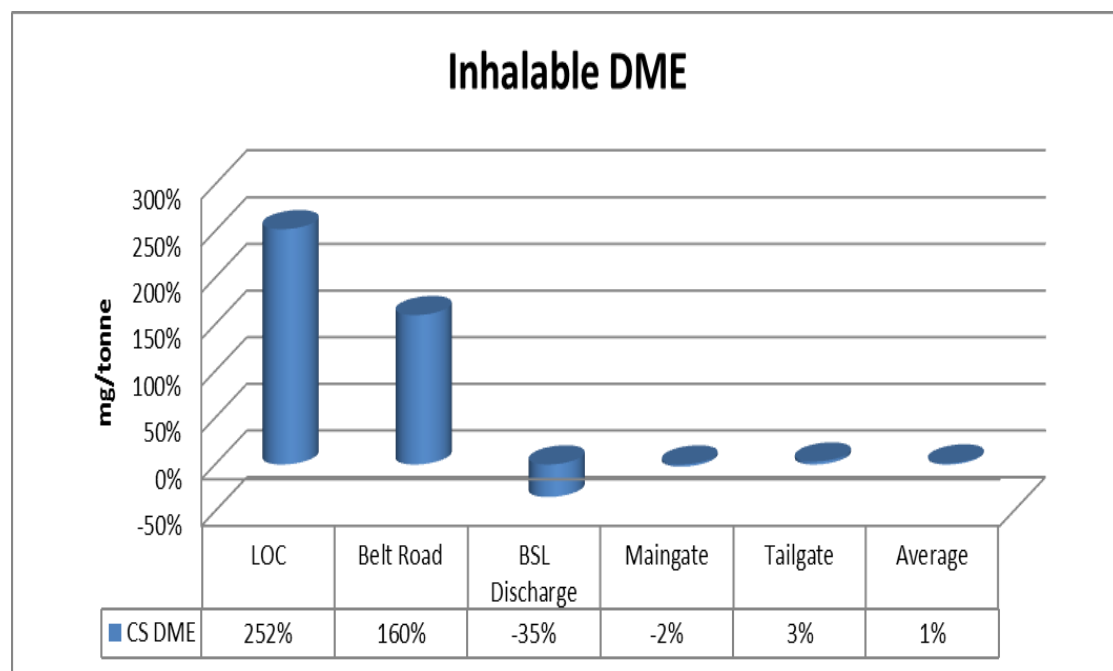
The last open cut-through showed a respirable dust load *decrease* of 28% with the scrubber operating. This indicates that the ventilation is performing as required. The belt road showed an *increase* of 50% for respirable dust. This is a huge increase in respirable dust loads and would indicate that a significant change or activity was present during this test. Inbye of the BSL discharge showed a *decrease* of 22% for respirable dust with the scrubber operating, the maingate showed an *increase* in respirable dust of 5% and the tailgate showed a *decrease* in respirable dust loads of 15%.

### 8.13.4 Inhalable Dust Analysis

Figure 8.48 summarises the inhalable data collected for Mine C. Figure 8.49 summarises the inhalable DME for Mine C.



**Figure 8.48 Mine C, Test 13 Inhalable Dust Production**



**Figure 8.49 Mine C, Test 13 Inhalable DME**

### 8.13.5 Inhalable DME Discussion

The LOC showed a 252% *increase* in inhalable dust loads, indicating that outbye works or some other outbye activity was having a significant effect on the inhalable dust loads being brought to the longwall on the intake ventilation. The inhalable DME in the belt road also showed a 160% *increase*. Further investigations need to be undertaken to determine if a roller was changed, sprays were not working or if some other activity created this increase in respirable and inhalable dust loads.

Inhalable dust loads at the BSL discharge showed a *decrease* of 35% with the scrubber operating and the inhalable dust *decreased* by 2% with the scrubber operating at the maingate. The inhalable dust load showed a 3% *increase* at the tailgate

### 8.13.6 DME Conclusion

Coal Services data collection and results showed that the operating scrubber *decreased* the respirable dust loads by an average of 13%. The inhalable dust loads showed an *increase* of an average 1%. This increase was due to high LOC and Belt Road readings for the second test. Mine C, Test 13 collected by Coal Services showed

## CHAPTER EIGHT

### Data Analysis and Discussion

that the operating scrubber reduced the amount of respirable and inhalable dust loads by 22% and 35% respectively at the BSL discharge. The maingate showed an *increase* in respirable dust of 5% with the scrubber operating and the corresponding inhalable dust *decreased* by 2% with the scrubber operating.

Whilst these results are encouraging, to ascertain the actual DME of the operating scrubber on the respirable and inhalable dust loads, the collected results were compared to the actual benchmark testing undertaken in Mine C, Test 4. These results will be discussed in 8.14.7.

## 8.14 Results Mine C Test 14

Mine C, Test 14 was undertaken by the author as a parallel test to Mine C, Test 13. Data collected was compared to the data collected by Coal Services and analysed to ensure uniformity of results. Data collection mirrored Coal Services.

### 8.14.1 Respirable and Inhalable Dust Raw Data

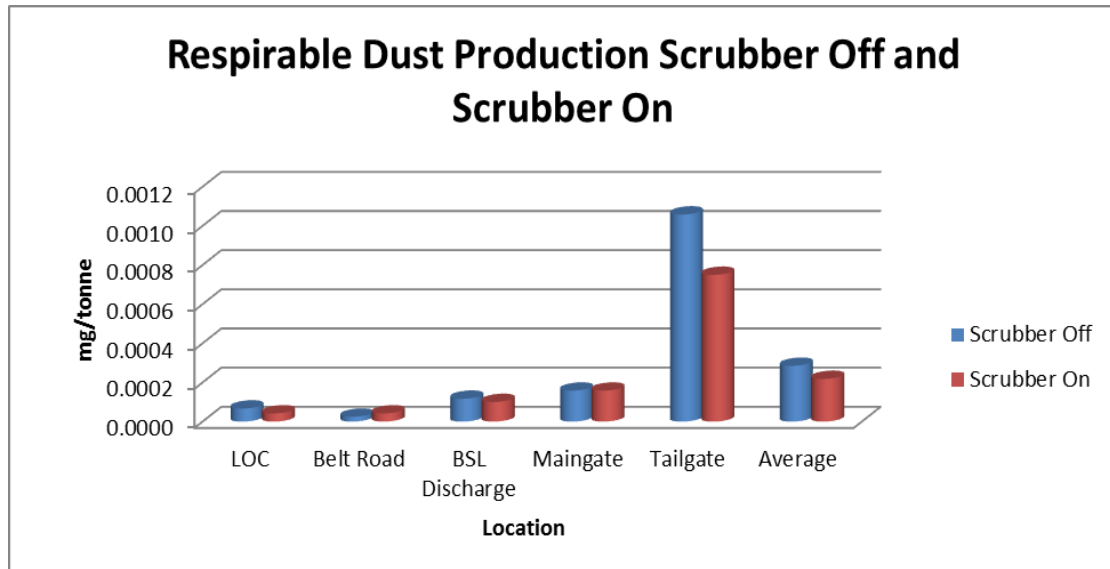
Table 8.17 summarises the raw data collected for respirable and inhalable dust production at Mine C.

**Table 8.17 Mine C, Test 14 Raw Data**

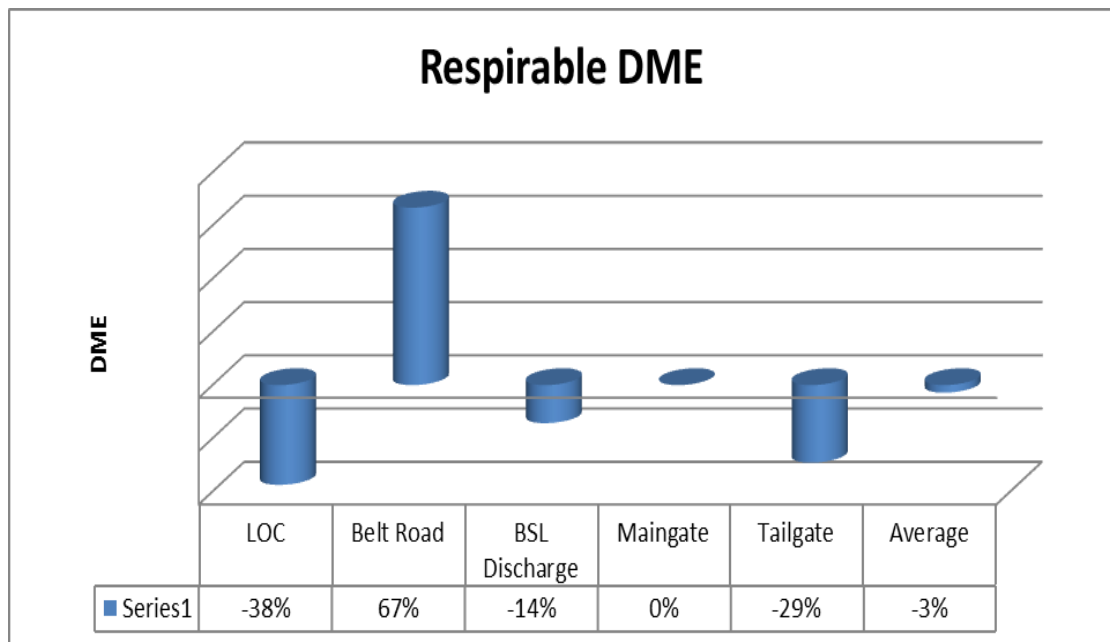
<b>Efficiency Test</b>								
<b>Respirable Dust Benchmark - No Scrubber</b>				<b>Respirable Dust Scrubber Operating</b>				
Sample ID	Initial Weight	Final Weight	Net weight	Sample ID	Initial Weight	Final Weight	Net weight	
LOC	7.13	7.21	0.08	LOC	7.42	7.47	0.05	
Belt Road	7.22	7.25	0.03	Belt Road	7.27	7.32	0.05	
BSL Discharge	7.23	7.37	0.14	BSL Discharge	7.17	7.29	0.12	
Maingate	7.38	7.57	0.19	Maingate	7.46	7.65	0.19	
Tailgate	7.38	8.65	1.27	Tailgate	7.11	8.01	0.9	
<b>Inhalable Dust Benchmark - No Scrubber</b>				<b>Inhalable Dust Scrubber Operating</b>				
Sample ID	Initial Weight	Final Weight	Net weight	Sample ID	Initial Weight	Final Weight	Net weight	
LOC	7.78	7.83	0.05	LOC	7.31	7.41	0.1	
Belt Road	7.77	7.81	0.04	Belt Road	7.18	7.29	0.11	
BSL Discharge	8.05	8.72	0.67	BSL Discharge	7.17	7.71	0.54	
Maingate	7.16	7.65	0.49	Maingate	7.25	7.86	0.61	
Tailgate	7.02	10.33	3.31	Tailgate	8	8.77	0.77	
Tonnes Benchmark		1200						
Tonnes Efficiency		1200						

**8.14.2 Respirable Dust Analysis**

Figure 8.50 summarises the respirable data collected for Mine C. Figure 8.51 summarises the respirable DME for Mine C.



**Figure 8.50 Mine C, Test 14 Respirable Dust Production**



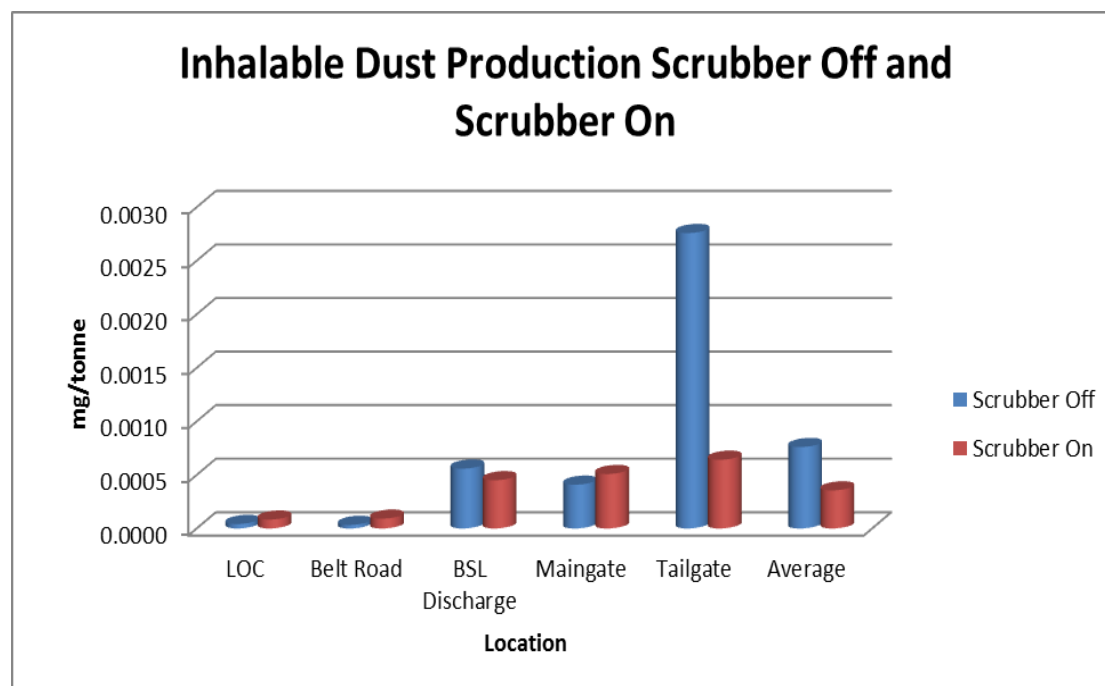
**Figure 8.51 Mine C, Test 14 Respirable DME**

### 8.14.3 Respirable DME Discussion

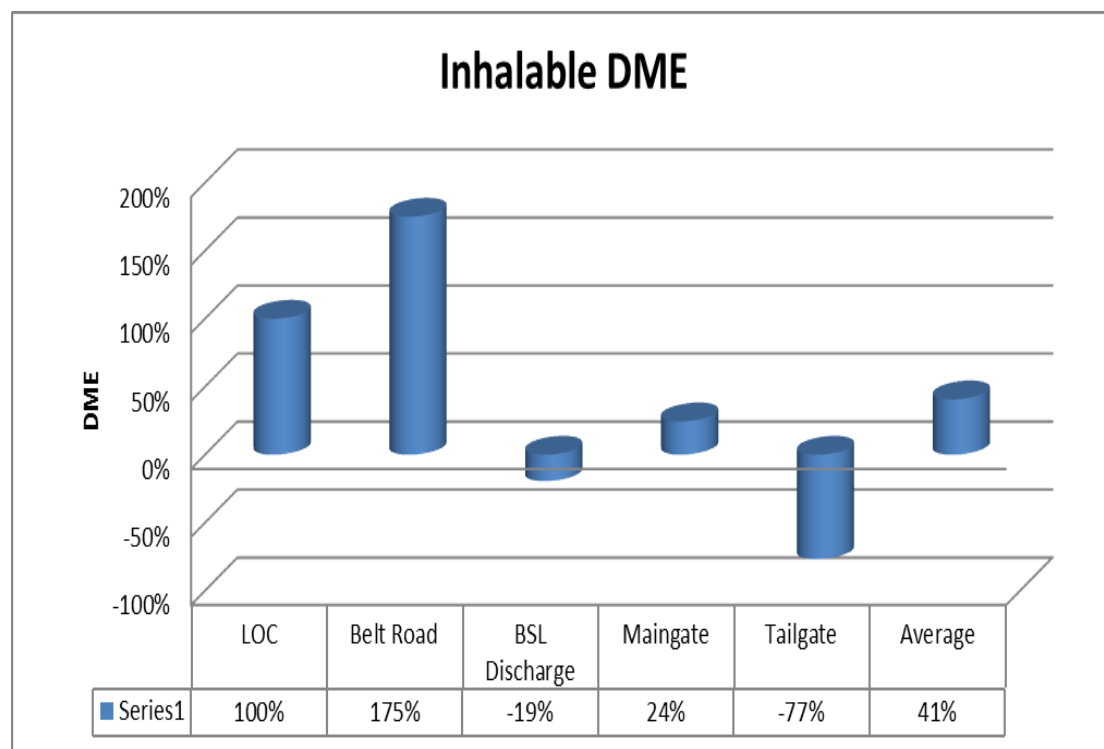
The last open cut-through showed a respirable dust load *decrease* of 38% with the scrubber operating. This indicates that the ventilation is performing as required. The belt road showed an *increase* of 67% for respirable dust. This is a huge increase in respirable dust loads and would indicate that a significant change or activity was present during this test. Inbye of the BSL discharge showed a *decrease* of 14% for respirable dust with the scrubber operating. The maingate showed no change in respirable dust with the scrubber operating and the tailgate showed a *decrease* in respirable dust loads of 29%.

### 8.14.4 Inhalable Dust Analysis

Figure 8.52 summarises the inhalable data collected for Mine C. Figure 8.53 summarises the inhalable DME for Mine C.



**Figure 8.52 Mine C, Test 14 Inhalable Dust Production**



**Figure 8.53 Mine C, Test 14 Inhalable DME**

### 8.14.5 Inhalable DME Discussion

The inhalable dust loads showed a 100% *increase*, indicating that outbye works or some other outbye activity was having a significant effect on the inhalable dust loads being brought to the longwall on the intake ventilation. The inhalable DME at the belt road also showed a 175% *increase*. Further investigations need to be undertaken to determine if a roller was changed, sprays were not working or if some other activity created this increase in inhalable dust loads. Inhalable dust loads at the BSL discharge showed a *decrease* of 19% with the scrubber operating whilst the maingate showed an *increase* of 24% with the scrubber operating. The inhalable dust load at the tailgate showed a 77% *decrease*.

### 8.14.6 DME Conclusion

Mine C, Test 14 results showed that the operating scrubber *decreased* the respirable dust loads by an average of 3%. The inhalable dust loads showed an *increase* of an average 41%. This increase was due to high LOC and belt road readings for the second test.

Mine C, Test 14 showed that the operating scrubber reduced the amount of respirable and inhalable dust loads by 14% and 19% respectively at the BSL discharge. The maingate showed no change in respirable dust with the scrubber operating and the corresponding inhalable dust *increased* by 24% with the scrubber operating.

Whilst these results are encouraging, to ascertain the actual DME of the operating scrubber on the respirable and inhalable dust loads, the collected results were compared to efficiency testing undertaken in Mine C, Test 4 . These results will be discussed in 8.14.7 in detail.

### **8.14.7 Mine C, Test 13 & 14 DME Comparison to Test 4**

To obtain an accurate measurement of the new installed scrubber efficiency, collected data was compared to benchmark analysis undertaken in Mine C, Test 4 in 8.4. This has resulted from Tests 13 & 14 being collected with the benchmark tests being collected with all controls operating excluding the scrubber. These results do not show how much respirable and inhalable dust is actually mitigated with installed controls operating. As seen in 8.4, turning the controls on in some locations actually increased the amount of dust measured. This set of collected data has established an operating respirable and inhalable dust load production benchmark at each source of dust generation and the utilisation of this benchmark will give an accurate DME for scrubber performance.

#### **8.14.7.1 Respirable and Inhalable DME Using Test 4 Benchmark**

Table 8.18 summarises raw data collected by Coal Services and UoW and compares the collected data.

**CHAPTER EIGHT**  
Data Analysis and Discussion

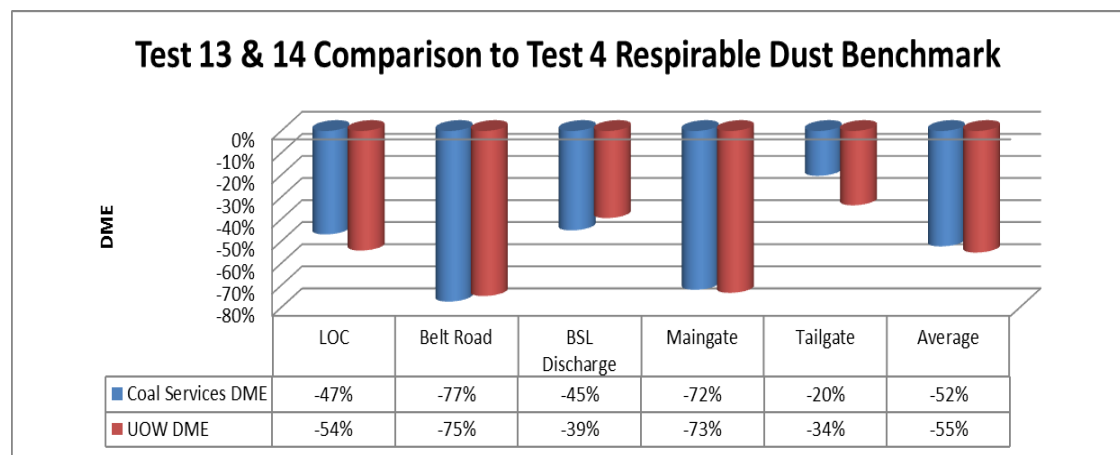
**Table 8.18 Mine C, Test 13 & 14 DME Comparison Using Test 4 Benchmark Raw Data**

		<b>Respirable DME</b>					
	LOC	Belt Road	BSL Discharge	Maingate	Tailgate	Average	
Test 4 Benchmark		0.0001	0.0002	0.0002	0.0006	0.0011	0.0004
Test 13 - Coal Services		0.0000	0.0000	0.0001	0.0002	0.0009	0.0002
Test 14 -UOW		0.0000	0.0000	0.0001	0.0002	0.0008	0.0002
Coal Services DME		-47%	-77%	-45%	-72%	-20%	-52%
UOW DME		-54%	-75%	-39%	-73%	-34%	-55%

		<b>Inhalable DME</b>					
	LOC	Belt Road	BSL Discharge	Maingate	Tailgate	Average	
Test 4 Benchmark		0.0005	0.0003	0.0005	0.0008	0.0045	0.0013
Test 13 - Coal Services		0.0001	0.0001	0.0004	0.0004	0.0028	0.0008
Test 14 -UOW		0.0001	0.0001	0.0005	0.0005	0.0000	0.0002
Coal Services DME		-69%	-73%	-25%	-53%	-36%	-51%
UOW DME		-82%	-72%	-7%	-40%	-100%	-60%

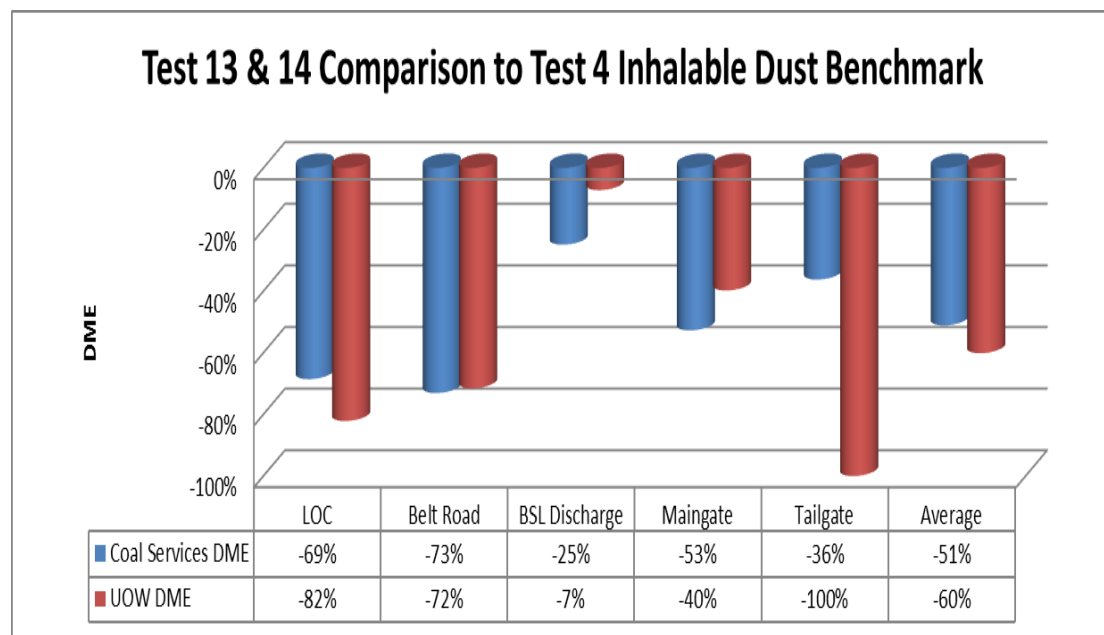
Figure 8.54 shows a respirable dust production comparison.



**Figure 8.54 Mine C, Test 13 and 14 Respirable DME Comparison Using Test 4 Benchmark**

Figure 8.55 shows an inhalable dust production comparison.





**Figure 8.55 Mine C, Test 13 and 14 Inhalable DME Comparison Using Test 4 Benchmark**

#### **8.14.7.2 Respirable and Inhalable DME Discussion**

The results of Test 13 and 14 significantly improve for both sets of collected data when DME calculations include Test 4 benchmark dust production results. The average DME for respirable dust *decreases* by 52% for data collected by Coal Services and 55% when collected by the Uow. These results are very close for both tests and further prove the robustness and flexibility of the new testing methodology.

The corresponding average inhalable DME shows *decreases* of 51% for Coal Services data and 60% for data collected by this author.

### **8.15 Results Mine E Test 15**

A second set of control efficiency sampling was undertaken at Mine E to measure the changes in the respirable and inhalable dust production as a result of implemented changes to the longwall ventilation introduced to further reduce exposure levels on the longwall. The major change to the intake ventilation was the installation of a maingate

**CHAPTER EIGHT**  
Data Analysis and Discussion

---

goaf curtain between the front and rear conveyors which forced the intake air down the front AFC instead of into the rear AFC and the goaf.

**8.15.1 Respirable and Inhalable Dust Raw Data**

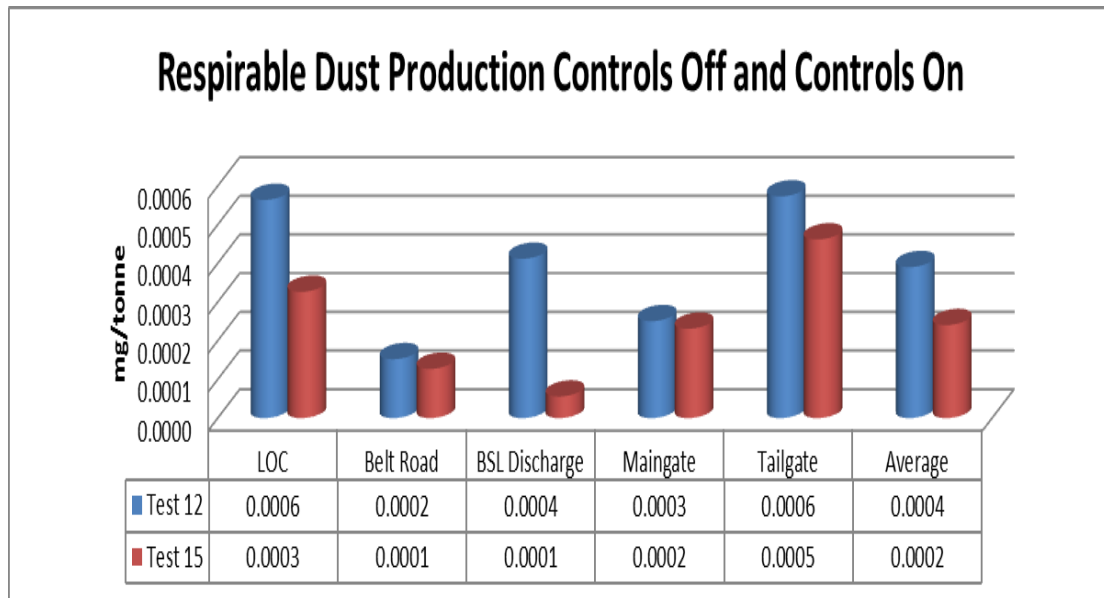
Table 8.19 summarise the raw data for respirable and inhalable dust production at Mine E.

**Table 8.19 Mine E, Test 15 Raw Data**

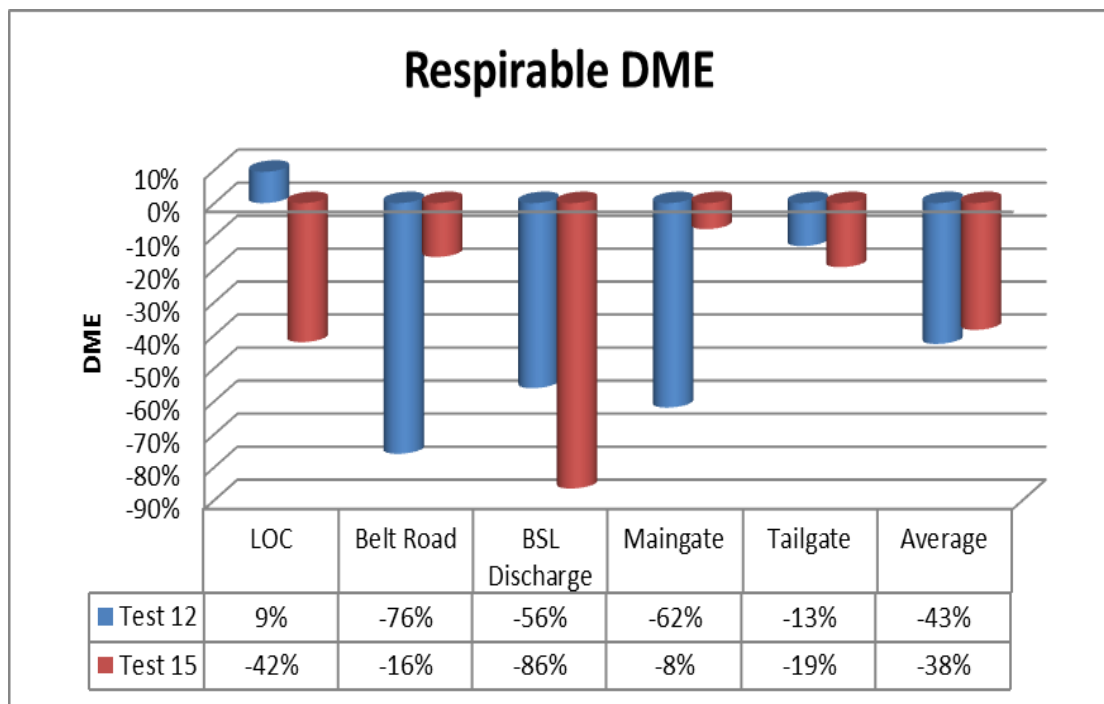
<u>Respirable Dust Benchmark</u>				<u>Respirable Dust Test 1</u>				<u>Respirable Dust Test 2</u>			
Sample ID	Initial Weight	Final Weight	Net weight	Sample ID	Initial Weight	Final Weight	Net weight	Sample ID	Initial Weigh	Final Weight	Net weight
LOC	7.08	7.69	0.61	LOC	7.34	7.97	0.63	LOC	7.35	7.76	0.41
Belt Road	7.02	7.77	0.75	Belt Road	7.13	7.3	0.17	Belt Road	7.26	7.42	0.16
BSL Discharge	6.97	8.08	1.11	BSL Discharge	7.54	8	0.46	BSL Discharge	7.3	7.37	0.07
Maingate	7.18	7.96	0.78	Maingate	7.71	7.99	0.28	Maingate	6.91	7.2	0.29
Tailgate	7.11	7.89	0.78	Tailgate	7.54	8.18	0.64	Tailgate	7.41	7.99	0.58
<u>Inhalable Dust Benchmark</u>				<u>Inhalable Dust Test 1</u>				<u>Inhalable Dust Test 2</u>			
Sample ID	Initial Weight	Final Weight	Net weight	Sample ID	Initial Weight	Final Weight	Net weight	Sample ID	Initial Weigh	Final Weight	Net weight
LOC	7.3	7.89	0.59	LOC	7.54	8.06	0.52	LOC	7.73	7.9	0.17
Belt Road	7.2	7.73	0.53	Belt Road	7.45	7.62	0.17	Belt Road	7.2	7.89	0.69
BSL Discharge	7.51	7.66	0.15	BSL Discharge	7.44	8.1	0.66	BSL Discharge	7.24	8.13	0.89
Maingate	7.94	8.18	0.24	Maingate	7.3	8.16	0.86	Maingate	7.24	7.88	0.64
Tailgate	7.48	8.14	0.66	Tailgate	7.21	8.2	0.99	Tailgate	7.41	8.4	0.99
Tonnes Benchmark		1184									
Tonnes Test 1		1117									
Tonnes Test 2		1256									

**8.15.2 Respirable Dust Analysis**

Figure 8.56 summarises the respirable data collected for Mine E. Figure 8.57 summarises the respirable DME for Mine E.



**Figure 8.56 Mine E, Test 15 Respirable Dust Production**



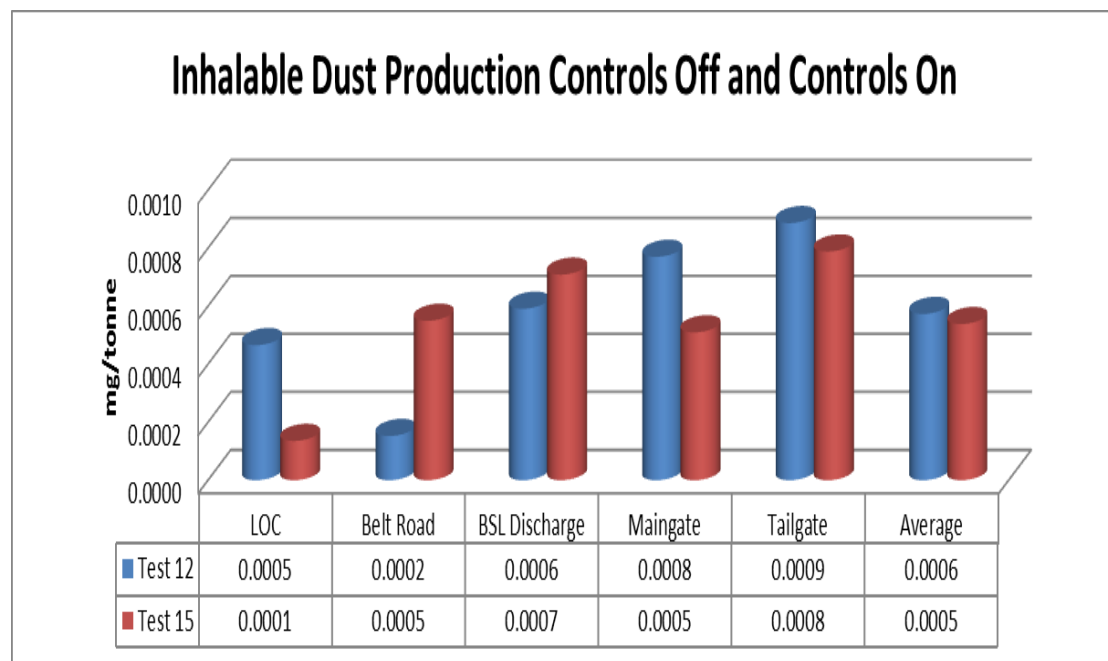
**Figure 8.57 Mine E, Test 15 Respirable DME**

### 8.15.3 Respirable DME Discussion

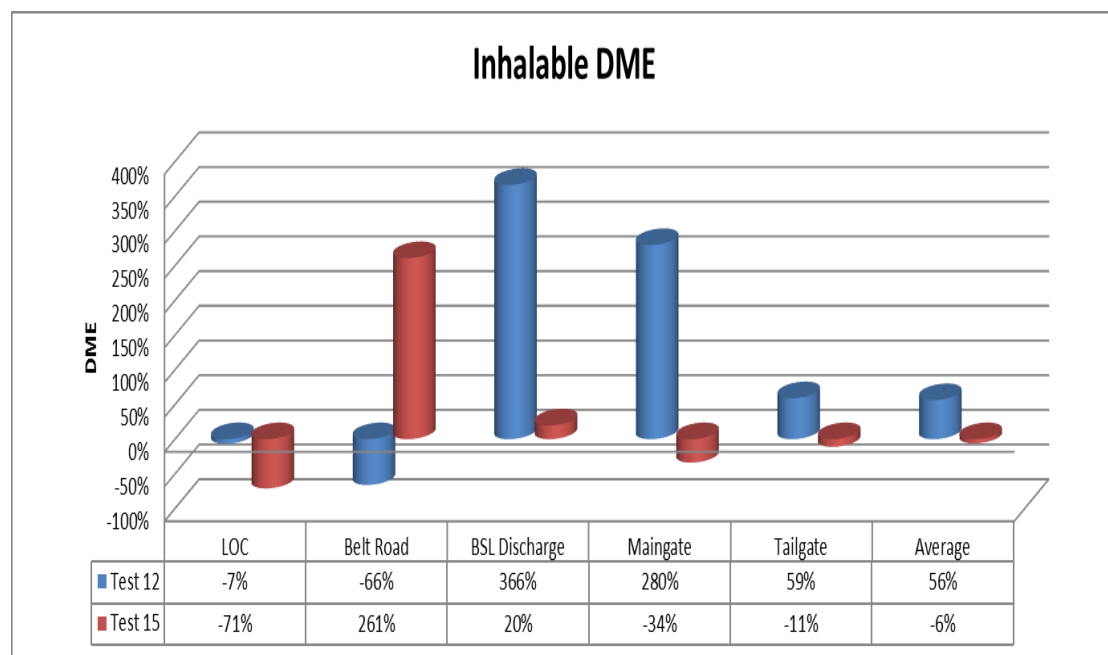
Test 15 was performed to quantify improvements to the ventilation by the addition of a brattice wing between the front and rear conveyors. The average results for the respirable dust loads remained approximately the same as the first test.

### 8.15.4 Inhalable Dust Analysis

Figure 8.58 summarises the inhalable data collected for Mine E. Figure 8.59 summarises the inhalable DME for Mine E.



**Figure 8.58 Mine E, Test 15 Inhalable Dust Production**



**Figure 8.59 Mine E, Test 15 Inhalable DME**

### 8.15.5 Inhalable DME Discussion

The average results indicate a significant improvement in the amount of inhalable dust removed from the atmosphere. Mine E. Test 12 showed that the average inhalable dust level *increased* by 56% when the controls were turned on, while the second test showed an average *decrease* of 6%.

### 8.15.6 DME Discussion

The respirable DME has remained similar to the first test which is to be expected. However, the inhalable dust loads were significantly reduced indicating that the installed brattice wing has been successful in mitigating inhalable dust loads. Further reductions in respirable and inhalable dust production will be achieved as additional engineering controls are installed and tested.

### 8.15.7 DME Conclusion

The second control efficiency test was compared to the first control efficiency test and DME's calculated. Table 8.20 summarises the results from tests 12 and 13 at Mine E.

**Table 8.20 Test 12 and 13 Comparison**

<b>Test</b>	<b>Respirable DME</b>	<b>Inhalable DME</b>
Test 12	-43%	56%
Test 15	-38%	-6%

Mine E advised that they have passed their first inhalable test from Coal Services in the last 6 years. They have attributed this success to the DME model and have indicated that they will be undertaking further tests as new, or alternative engineering controls are installed.

### **8.16 Cumulative Average DME Analysis**

The DME model detailed in this thesis has been successful in identifying which installed engineering controls mitigate the most respirable and inhalable dust produced during the cutting cycle at each known source of dust generation on an operating longwall. By identifying which controls mitigate the most dust, mining company engineers can integrate these engineering controls into their operating longwalls, ensuring statutory compliance to legislated exposure levels, further ensuring the continued and improved health and safety of employees.

This section will quantify the respirable and inhalable dust loads produced at each known source of generation presented as a mg/tonne produced during the cutting cycle, clearly define which mine tested produces the least amount of respirable and inhalable dust during the cutting cycle, which mines installed engineering controls mitigate the most respirable and inhalable dust and conclude with a parametric setup for an operating longwall to mitigate the maximum amount of respirable and inhalable dust produced during the cutting cycle.

### **8.17 Benchmark Respirable Dust Load Production**

Of the 190 respirable samples collected, 66 of these were benchmark samples. Benchmark samples are defined as those samples taken with all controls turned off excluding pick sprays necessary to mitigate the risk of frictional ignition. These

## CHAPTER EIGHT

### Data Analysis and Discussion

collected benchmark samples were analysed at each of the known sources of dust generation and compared to a mine respirable and inhalable dust production average, with this average then underpinning the average respirable dust production for each mine sampled, and identifying which mine produces the most mg/tonne of respirable dust during the cutting cycle. It should be noted that no benchmark respirable samples were taken at Mine D.

Table 8.21 details the collected respirable dust samples undertaken for benchmark determination. The collected samples have been placed in mine order with the collected samples averaged over the amount of samples taken at the known sources of dust generation. These averages have then been analysed in detail.

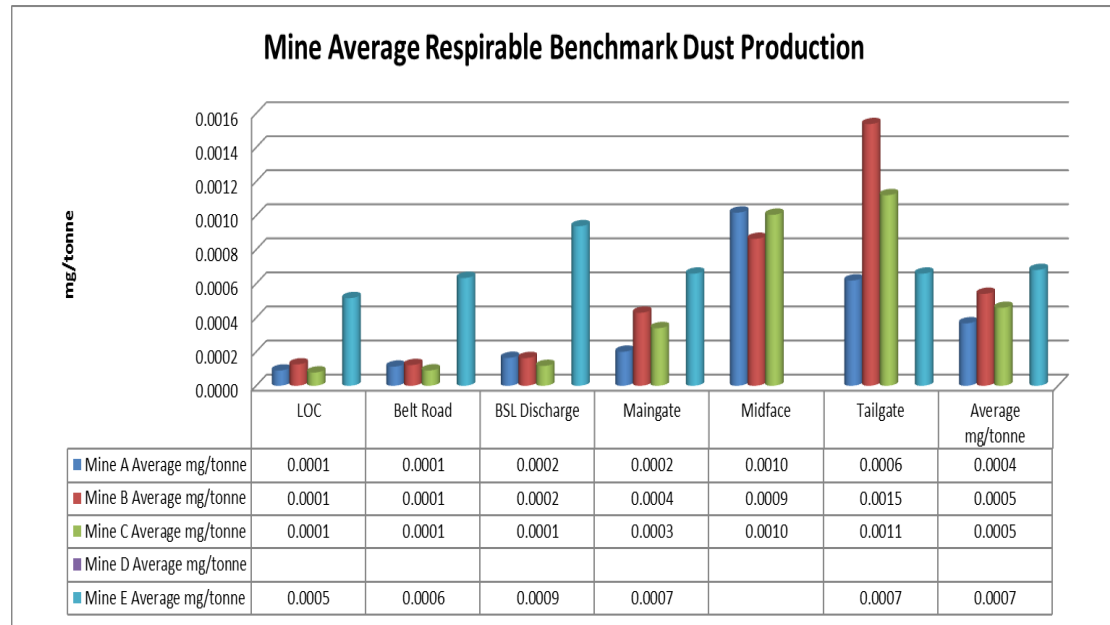
**Table 8.21 Respirable Dust Production Benchmark Samples**

	LOC	Belt Road	BSL Discharge	Maingate	Midface	Tailgate	Average mg/tonne
Test 1-Mine A	0.0001	0.0001	0.0002	0.0002	0.0010	0.0006	
Mine A Average mg/tonne	<b>0.0001</b>	<b>0.0001</b>	<b>0.0002</b>	<b>0.0002</b>	<b>0.0010</b>	<b>0.0006</b>	<b>0.0004</b>
Test 2-Mine B	0.0001	0.0002	0.0002	0.0003	0.0007	0.0012	
Test 6-Mine B	0.0002	0.0001	0.0002	0.0002			
Test 7-Mine B				0.0007	0.0009	0.0016	
Test 10-Mine B				0.0007	0.0009	0.0016	
Test 11-Mine B	0.0001	0.0000	0.0001	0.0004	0.0010	0.0016	
Mine B Average mg/tonne	<b>0.0001</b>	<b>0.0001</b>	<b>0.0002</b>	<b>0.0004</b>	<b>0.0009</b>	<b>0.0015</b>	<b>0.0005</b>
Test 3-Mine C	0.0001	0.0001	0.0000	0.0000	0.0008	0.0011	
Test 4-Mine C	0.0001	0.0002	0.0002	0.0006	0.0012	0.0011	
Test 5-Mine C	0.0002	0.0002	0.0002	0.0008	0.0011	0.0014	
Test 13-Mine C	0.0001	0.0000	0.0001	0.0002		0.0011	
Test 14-Mine C	0.0000	0.0000	0.0001	0.0001		0.0009	
Mine C Average mg/tonne	<b>0.0001</b>	<b>0.0001</b>	<b>0.0001</b>	<b>0.0003</b>	<b>0.0010</b>	<b>0.0011</b>	<b>0.0005</b>
Test 8-Mine D							
Test 9-Mine D							
Mine D Average mg/tonne							
Test 12-Mine E	0.0005	0.0006	0.0009	0.0007		0.0007	
Test 15-Mine E	0.0005	0.0006	0.0009	0.0007		0.0007	
Mine E Average mg/tonne	<b>0.0005</b>	<b>0.0006</b>	<b>0.0009</b>	<b>0.0007</b>		<b>0.0007</b>	<b>0.0007</b>

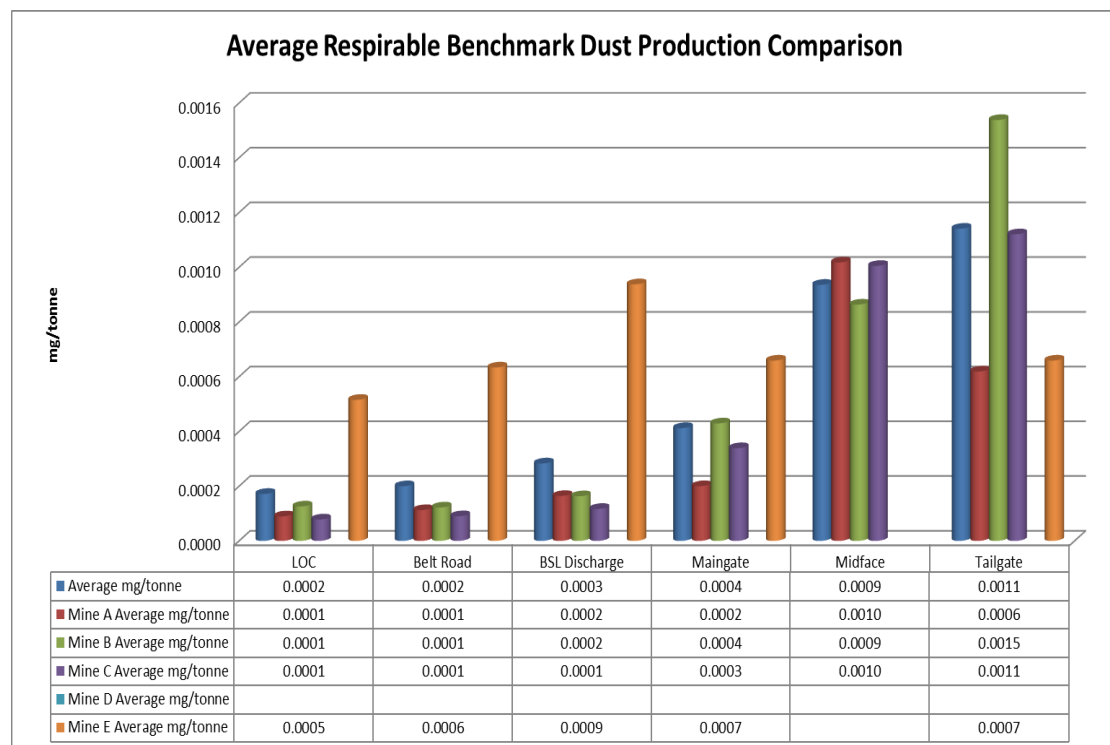
Figure 8.60 summarises the average mg/tonne of respirable dust produced during the cutting cycle with no engineering controls operating at each of the known sources of dust generation for each of the mines sampled. The average mg/tonne was calculated by adding together each of the collected samples and dividing the number by the amount of samples collected. This average was then used to compare the average of each sample collected at that location for each of the 15 tests undertaken at the 5 mines and is summarised in Figure 8.61, with Figure 8.62 showing the percentage

**CHAPTER EIGHT**  
Data Analysis and Discussion

difference that each mine obtained compared to the overall mine average. These measurements are discussed in detail in 8.18 at each identified source of respirable and inhalable dust generation.

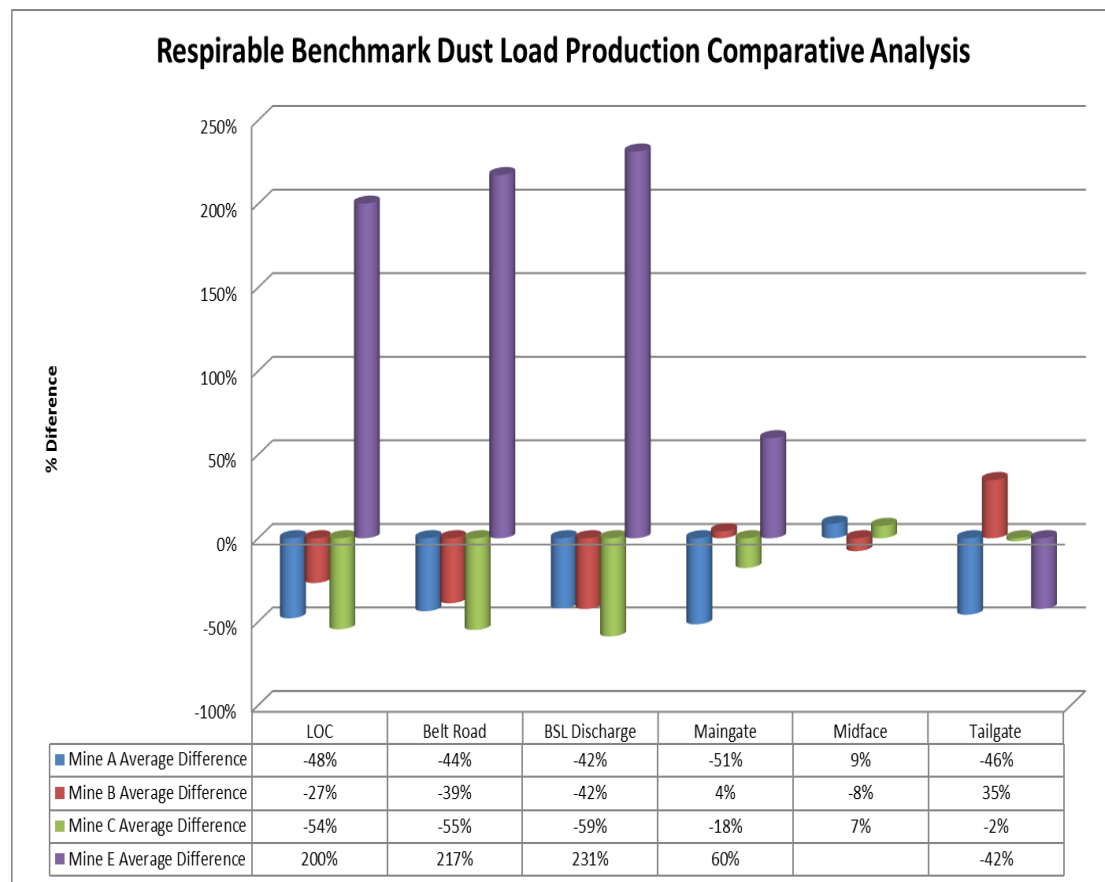


**Figure 8.60 Mine Average Respirable Benchmark Dust Production**



**Figure 8.61 Average Respirable Benchmark Dust Production Comparison**



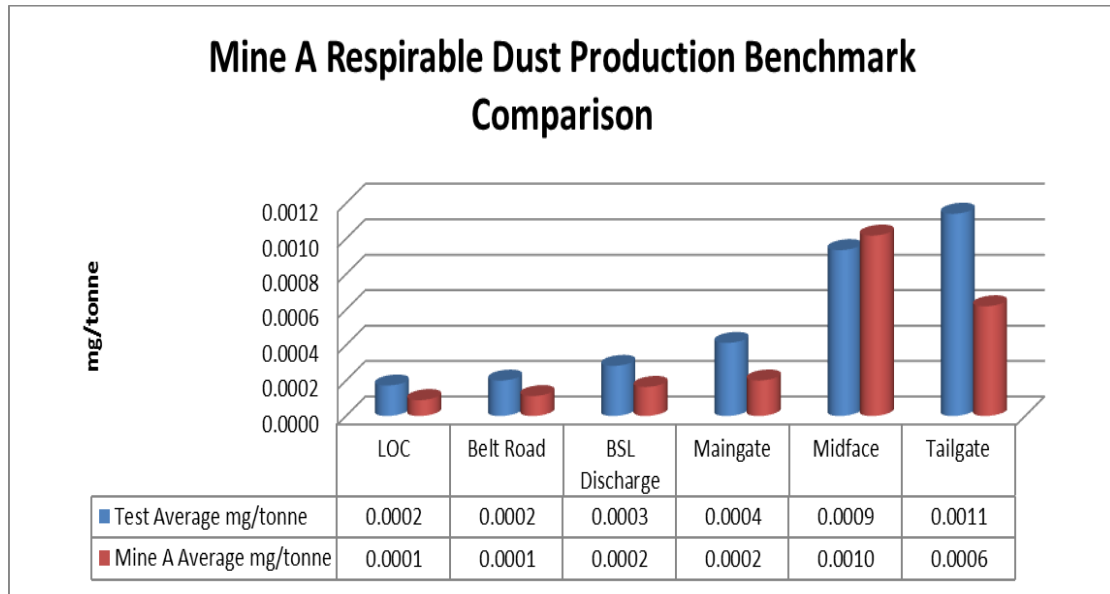


**Figure 8.62 Respirable Benchmark Dust Load Production Comparative Analysis**

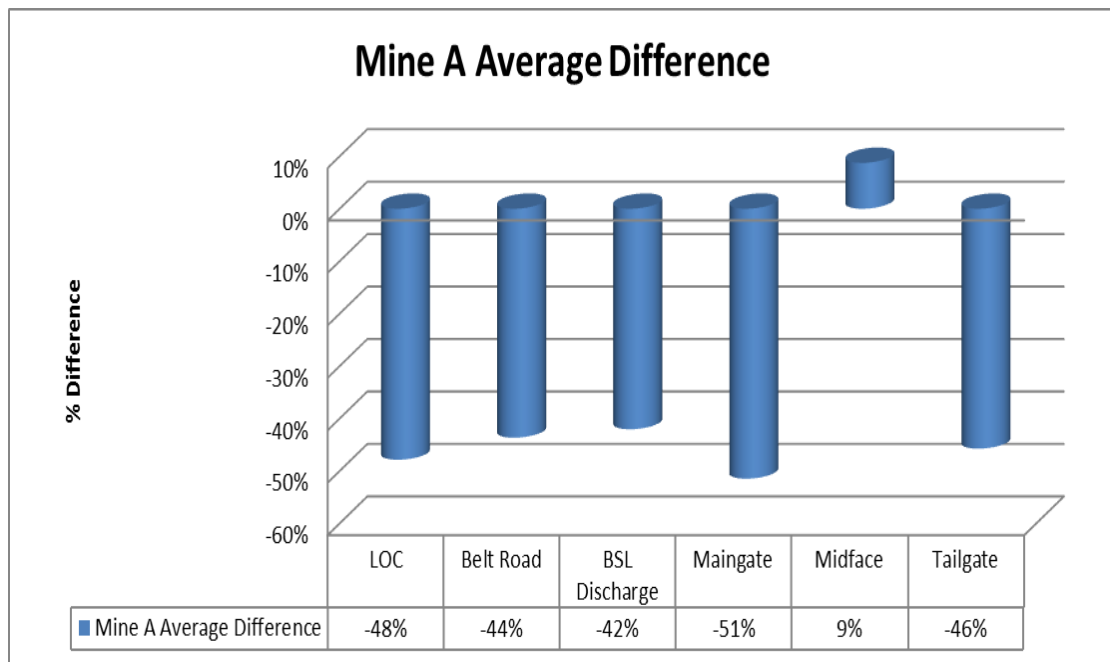
### 8.18 Benchmark Respirable Dust Load Production Comparative Analysis

This section analyses the measured respirable dust loads for each of the identified sources of dust generation and compares each of the 5 mines tested to the overall mine average at those locations. From this analysis, it can be determined which mine produced the most mg/tonne with no installed engineering controls operating and which mine produces the least. This section also identifies the average respirable dust load production from all mines at these independent sources.

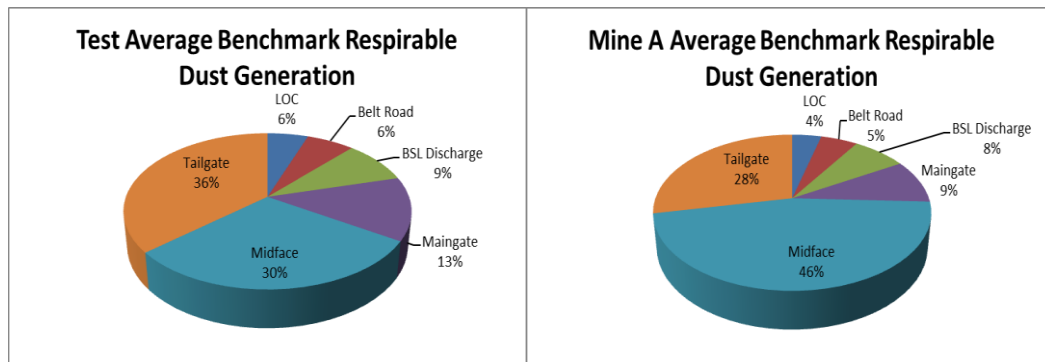
**8.18.1 Mine A Respirable Dust Load Production Analysis**



**Figure 8.63 Mine A Respirable Dust Production Benchmark Comparison**



**Figure 8.64 Mine A Average Respirable Dust Production Difference**



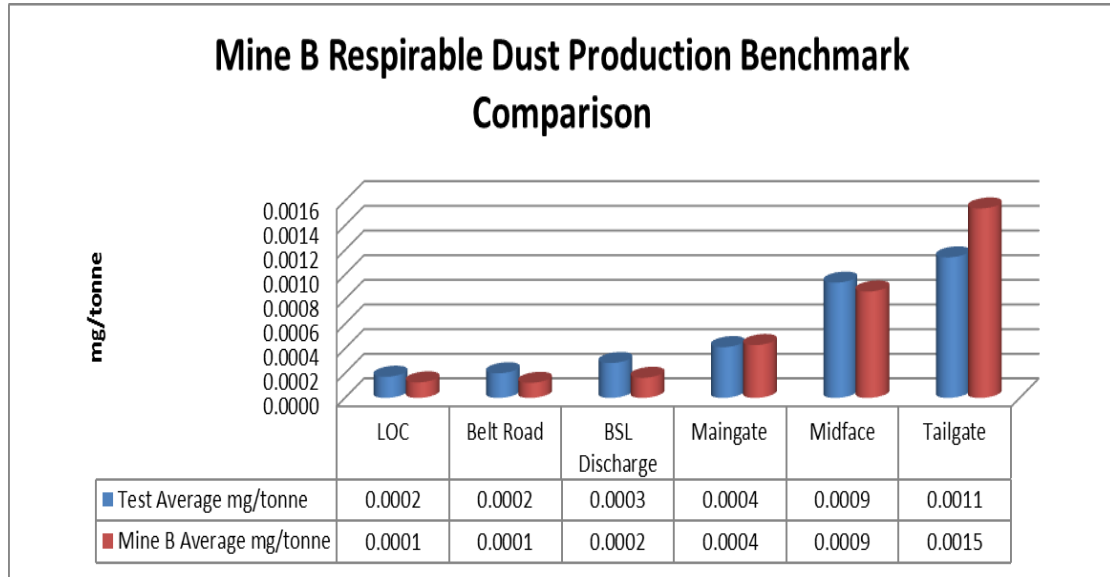
**Figure 8.65 Test Average and Mine A Average Respirable Benchmark Dust Production**

### 8.18.2 Mine A Respirable Benchmark Production Discussion

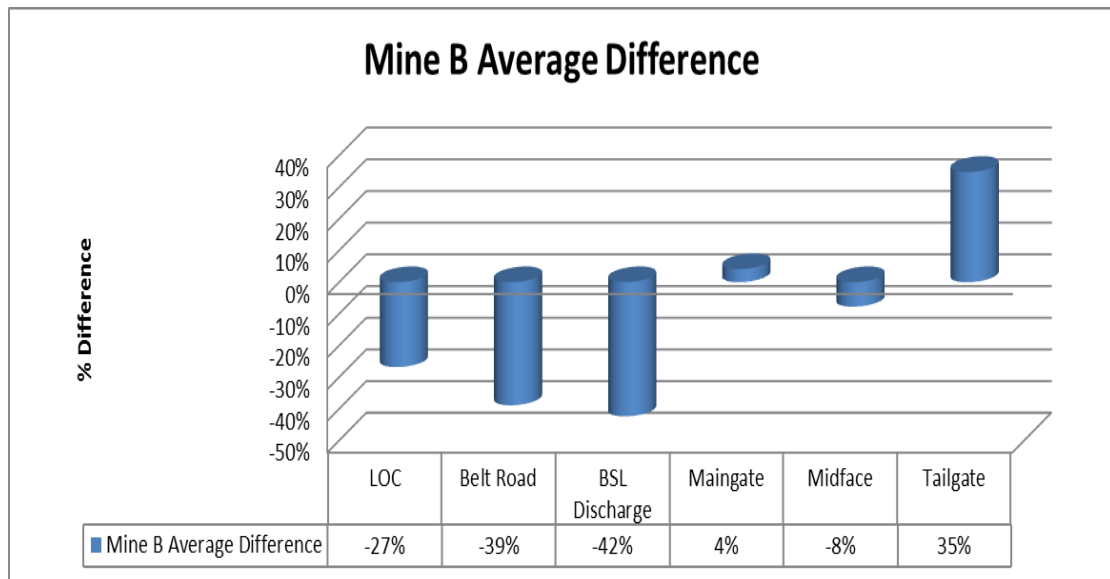
Figure 8.63 details the amount of respirable dust produced by Mine A during the cutting cycle at each location tested. This is compared to the average respirable dust produced at the same locations for all mines tested. Figure 8.64 shows that Mine A produced 48% less respirable dust at the LOC, 44% less at the belt road, 42% less at the BSL discharge, 51% less at the maingate, 9% more midface and 46% less than the average respirable dust production at the tailgate.

Figure 8.65 shows that the average respirable benchmark dust production of all mines tested is 6% from the LOC, 6% from the belt road, 9% from the BSL discharge, 13% from the maingate, 30% midface and 36% in the tailgate. Mine A's respirable benchmark dust production was 4% from the LOC, 5% from the belt road, 8% from the BSL discharge, 9% from the maingate, 46% midface and 28% in the tailgate.

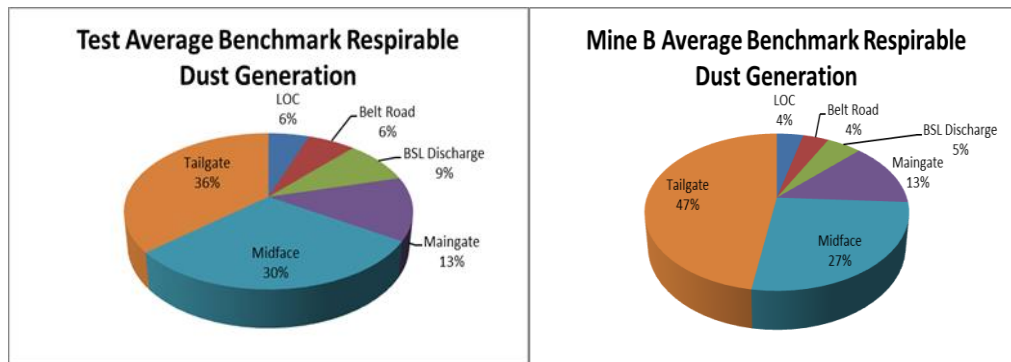
**8.18.3 Mine B Respirable Dust Load Production Analysis**



**Figure 8.66 Mine B Respirable Dust Production Benchmark Comparison**



**Figure 8.67 Mine B Average Respirable Dust Production Difference**



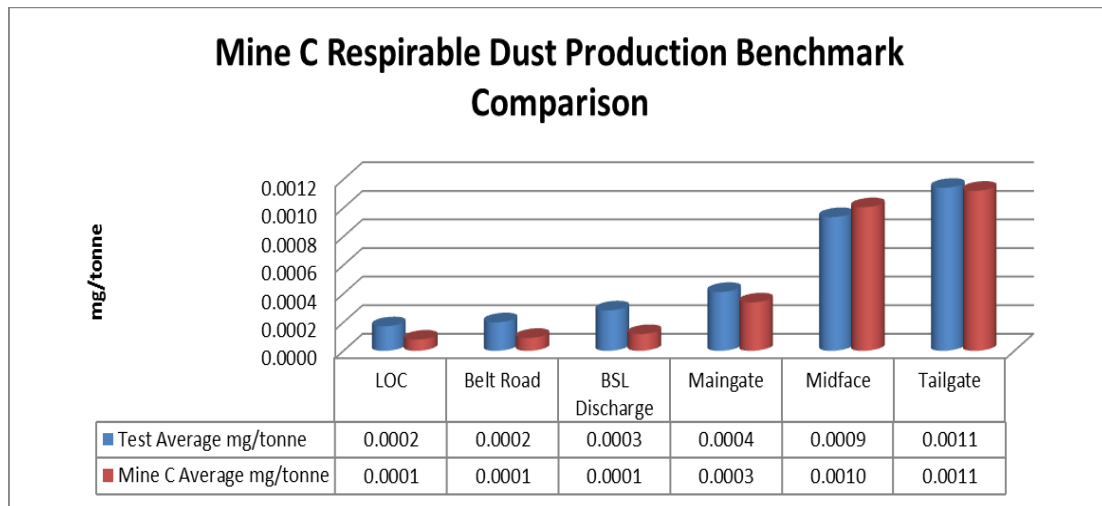
**Figure 8.68 Test Average and Mine B Average Respirable Benchmark Dust Production**

### **8.18.4 Mine B Respirable Benchmark Production Discussion**

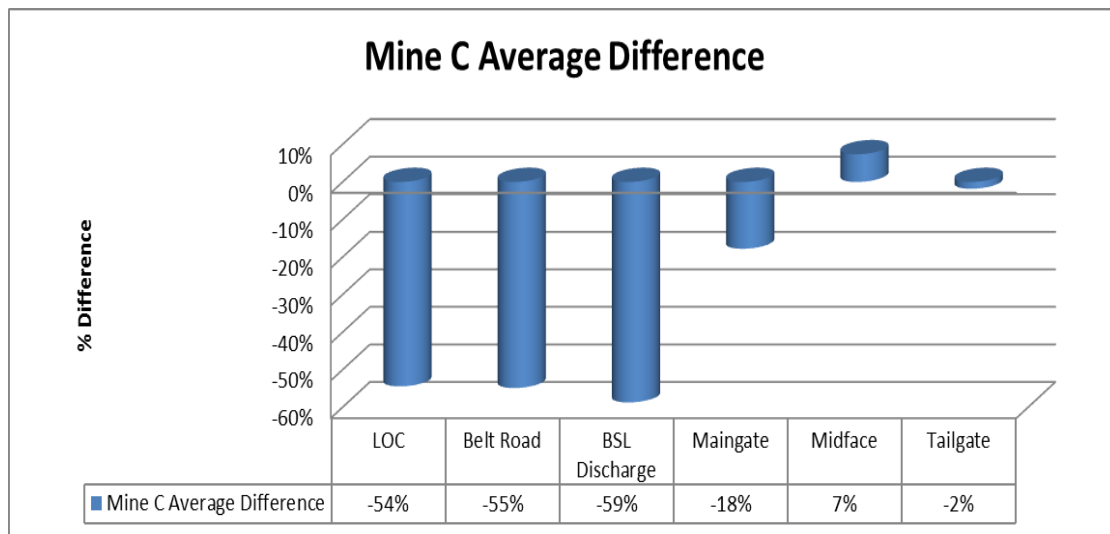
Figure 8.66 details the amount of respirable dust produced by Mine B during the cutting cycle at each location tested. This is compared to the average respirable dust produced at the same locations for all mines tested. Figure 8.67 shows that Mine B produced 27% less respirable dust at the LOC, 39% less at the belt road, 42% less at the BSL discharge, 4% more at the maingate, 8% less midface and 35% more than the average respirable dust production at the tailgate.

Figure 8.68 shows that the average respirable benchmark dust production of all mines tested is 6% from the LOC, 6% from the belt road, 9% from the BSL discharge, 13% from the maingate, 30% midface and 36% in the tailgate. Mine B's respirable benchmark dust production was 4% from the LOC, 4% from the belt road, 5% from the BSL discharge, 13% from the maingate, 27% midface and 47% in the tailgate.

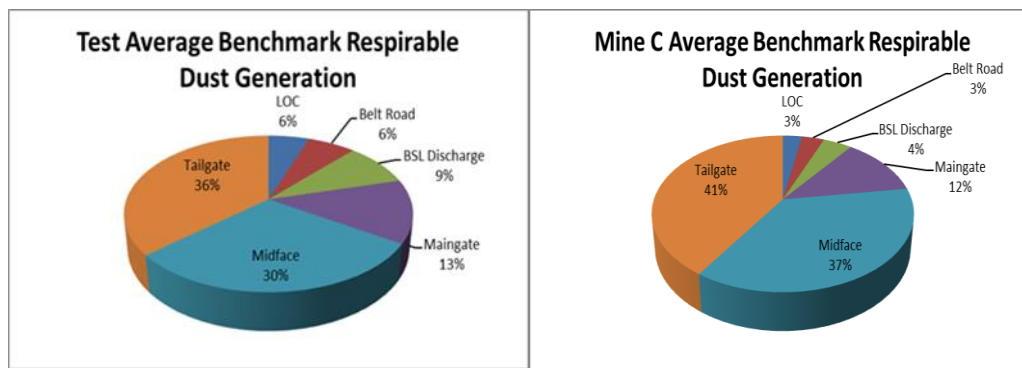
**8.18.5 Mine C Respirable Dust Load Production Analysis**



**Figure 8.69 Mine C Respirable Dust Production Benchmark Comparison**



**Figure 8.70 Mine C Average Respirable Dust Production Difference**



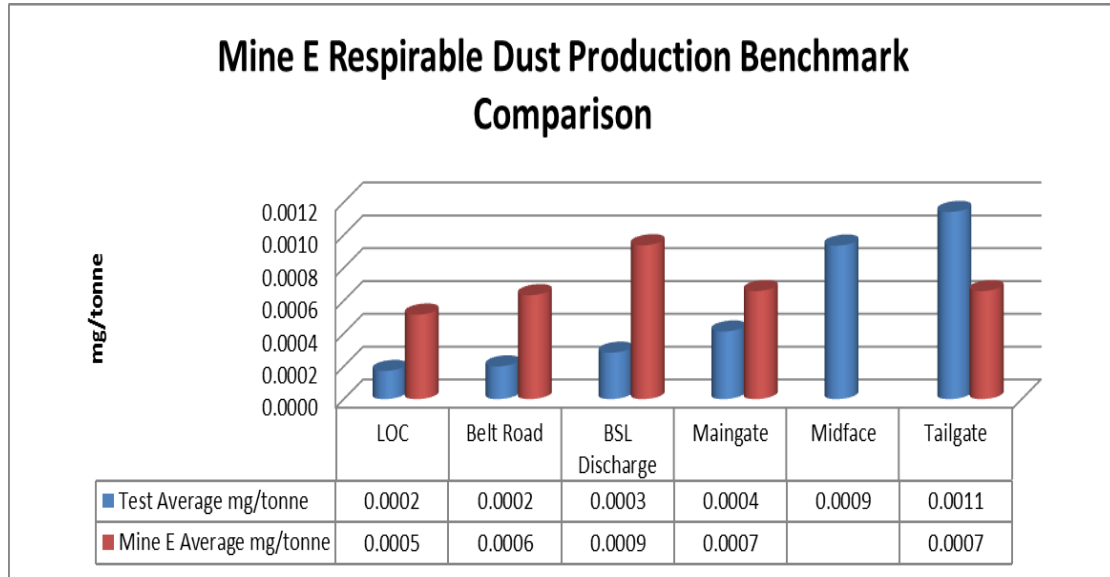
**Figure 8.71 Test Average and Mine C Average Respirable Benchmark Dust Production**

### 8.18.6 Mine C Respirable Benchmark Production Discussion

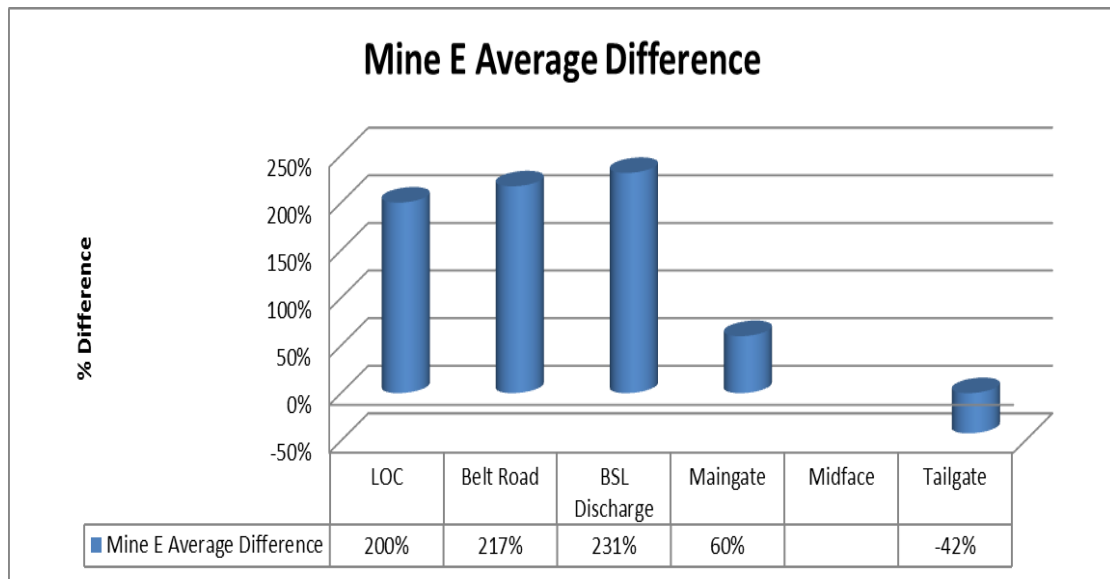
Figure 8.69 details the amount of respirable dust produced by Mine C during the cutting cycle at each location tested. This is compared to the average respirable dust produced at the same locations for all mines tested. Figure 8.70 shows that Mine C produced 54% less respirable dust at the LOC, 55% less at the belt road, 59% less at the BSL discharge, 18% less at the maingate, 7% more midface and 2% less than the average respirable dust production at the tailgate.

Figure 8.71 shows that the average respirable benchmark dust production of all mines tested is 3% from the LOC, 3% from the belt road, 4% from the BSL discharge, 12% from the maingate, 37% midface and 41% in the tailgate. Mine C's respirable benchmark dust production was 4% from the LOC, 4% from the belt road, 5% from the BSL discharge, 13% from the maingate, 27% midface and 47% in the tailgate.

**8.18.7 Mine E Respirable Dust Load Production Analysis**

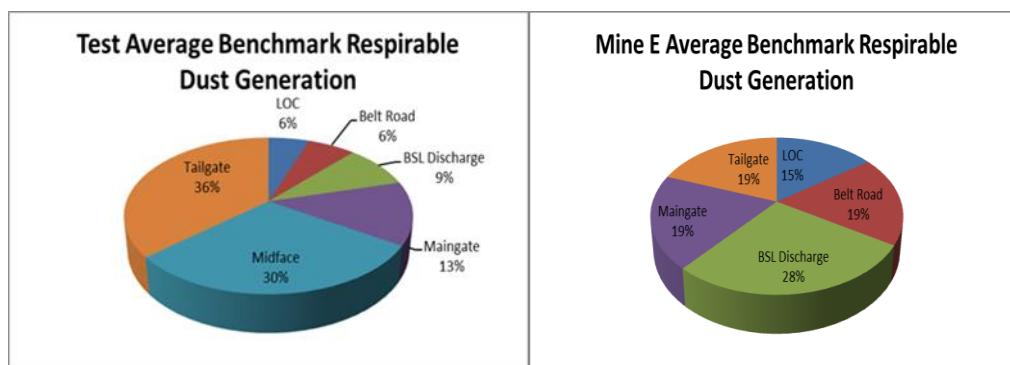


**Figure 8.72 Mine E Respirable Dust Production Benchmark Comparison**



**Figure 8.73 Mine E Average Respirable Dust Production Difference**





**Figure 8.74 Test Average and Mine E Average Respirable Benchmark Dust Production**

### 8.18.8 Mine E Respirable Benchmark Production Discussion

Figure 8.72 details the amount of respirable dust produced by Mine E during the cutting cycle at each location tested. This is compared to the average respirable dust produced at the same locations for all mines tested. Figure 8.73 shows that Mine E produced 200% more respirable dust at the LOC, 217% more at the belt road, 231% more at the BSL discharge, 60% more at the maingate, and 42% less than the average respirable dust production at the tailgate.

Figure 8.74 shows that the average respirable benchmark dust production of all mines tested is 6% from the LOC, 6% from the belt road, 9% from the BSL discharge, 13% from the maingate, 30% midface and 36% in the tailgate. Mine E's respirable benchmark dust production was 15% from the LOC, 19% from the belt road, 28% from the BSL discharge, 19% from the maingate, and 19% in the tailgate.

### 8.19 Benchmark Inhalable Dust Load Production

Of the 170 inhalable samples collected, 66 of these were benchmark samples. Benchmark samples are defined as those samples taken with all controls turned off excluding pick sprays necessary to mitigate the risk of frictional ignition. These collected benchmark samples were analysed at each of the known sources of dust generation and compared to a mine respirable and inhalable dust production average, with this average then underpinning the average respirable dust production for each mine sampled, and identifying which mine produces the most mg/tonne of inhalable

## CHAPTER EIGHT

### Data Analysis and Discussion

dust during the cutting cycle. It should be noted that no benchmark inhalable samples were taken at Mine D.

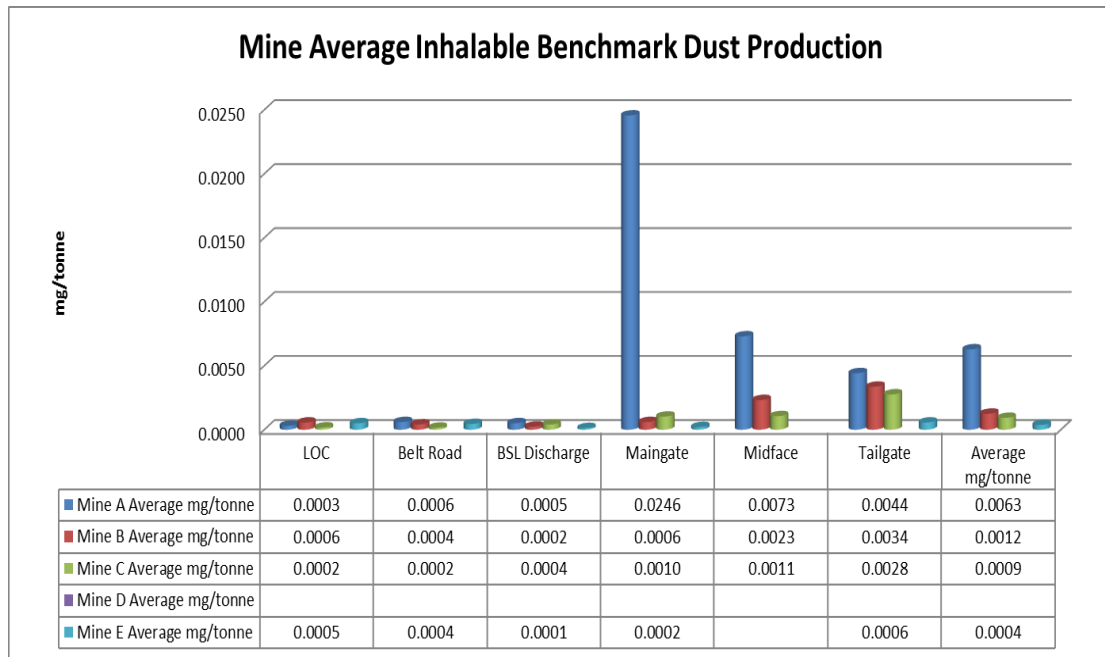
Table 8.22 details the collected inhalable dust samples undertaken for benchmark determination. The collected samples have been placed in mine order with the collected samples averaged over the amount of samples taken at the known sources of dust generation. These averages have then been analysed in detail.

**Table 8.22 Inhalable Dust Production Benchmark Samples**

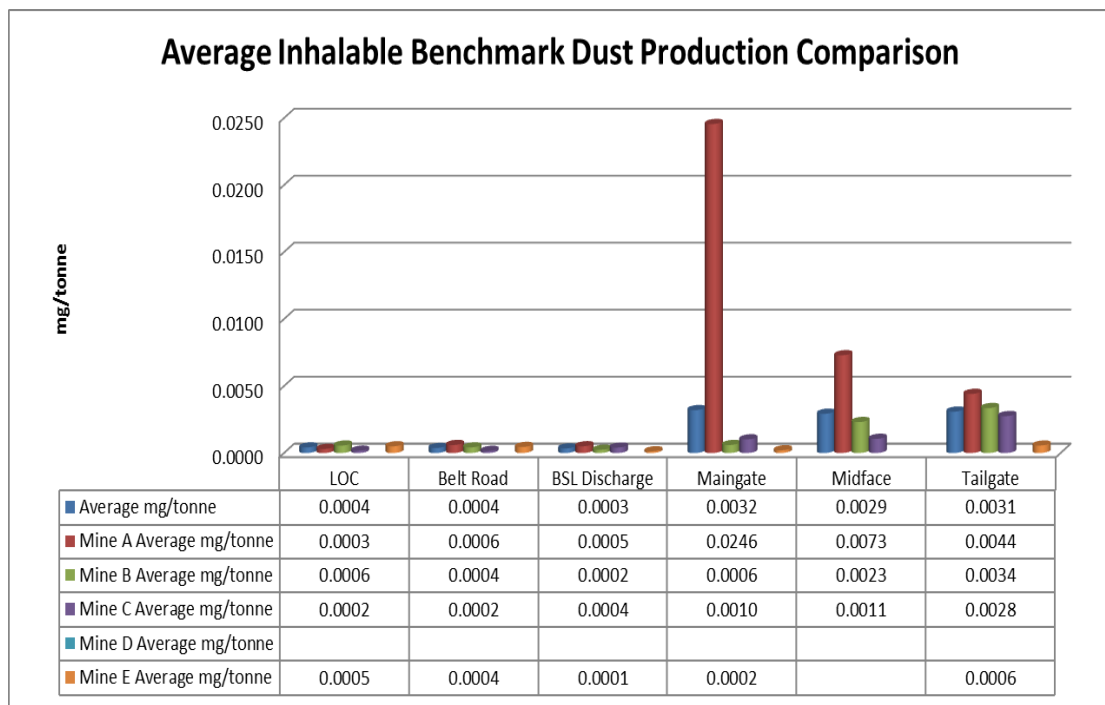
	LOC	Belt Road	BSL Discharge	Maingate	Midface	Tailgate	Average mg/ton
Test 1-Mine A	0.0003	0.0006	0.0005	0.0246	0.0073	0.0044	
Mine A Average mg/tonne	<b>0.0003</b>	<b>0.0006</b>	<b>0.0005</b>	<b>0.0246</b>	<b>0.0073</b>	<b>0.0044</b>	<b>0.0063</b>
Test 2-Mine B	0.0004	0.0007	0.0000	0.0006	0.0035	0.0066	
Test 6-Mine B	0.0010	0.0003	0.0004	0.0001			
Test 7-Mine B				0.0008	0.0024	0.0028	
Test 10-Mine B				0.0008	0.0024	0.0028	
Test 11-Mine B	0.0002	0.0003	0.0003	0.0006	0.0009	0.0012	
Mine B Average mg/tonne	<b>0.0006</b>	<b>0.0004</b>	<b>0.0002</b>	<b>0.0006</b>	<b>0.0023</b>	<b>0.0034</b>	<b>0.0012</b>
Test 3-Mine C	0.0002	0.0001	0.0003	0.0003	0.0008	0.0020	
Test 4-Mine C	0.0001	0.0001	0.0003	0.0004	0.0003	0.0017	
Test 5-Mine C	0.0005	0.0005	0.0004	0.0033	0.0021	0.0041	
Test 13-Mine C	0.0000	0.0000	0.0006	0.0004		0.0028	
Test 14-Mine C	0.0000	0.0000	0.0005	0.0007		0.0031	
Mine C Average mg/tonne	<b>0.0002</b>	<b>0.0002</b>	<b>0.0004</b>	<b>0.0010</b>	<b>0.0011</b>	<b>0.0028</b>	<b>0.0009</b>
Test 8-Mine D							
Test 9-Mine D							
Mine D Average mg/tonne							
Test 12-Mine E	0.0005	0.0004	0.0001	0.0002		0.0006	
Test 15-Mine E	0.0005	0.0004	0.0001	0.0002		0.0006	
Mine E Average mg/tonne	<b>0.0005</b>	<b>0.0004</b>	<b>0.0001</b>	<b>0.0002</b>		<b>0.0006</b>	<b>0.0004</b>

Figure 8.75 details the average mg/tonne of respirable dust produced during the cutting cycle with no engineering controls operating at each of the known sources of dust generation for each of the mines sampled. The average mg/tonne was calculated by adding together each of the collected samples and dividing the number by the amount of samples collected. This average was then used to compare the average of each sample collected at that location for each of the 15 tests undertaken at the 5 mines and is detailed in Figure 8.76, with Figure 8.77 showing the percentage difference that each mine obtained compared to the overall mine average.

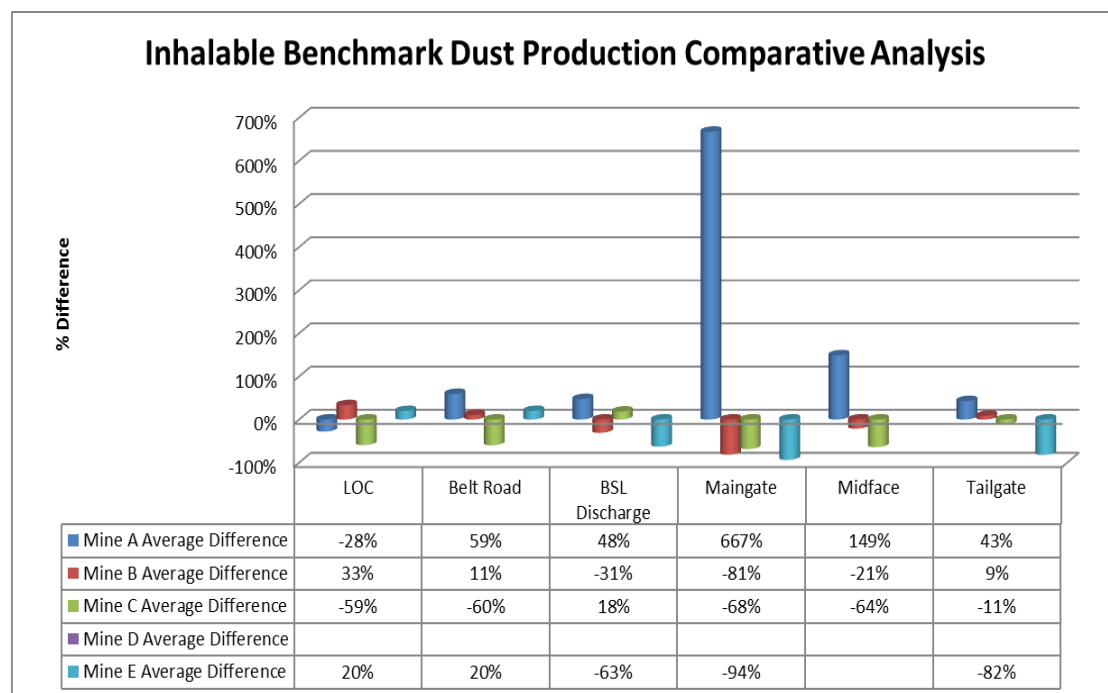
**CHAPTER EIGHT**  
Data Analysis and Discussion



**Figure 8.75 Mine Average Inhalable Benchmark Dust Production**



**Figure 8.76 Average Inhalable Benchmark Dust Production Comparison**

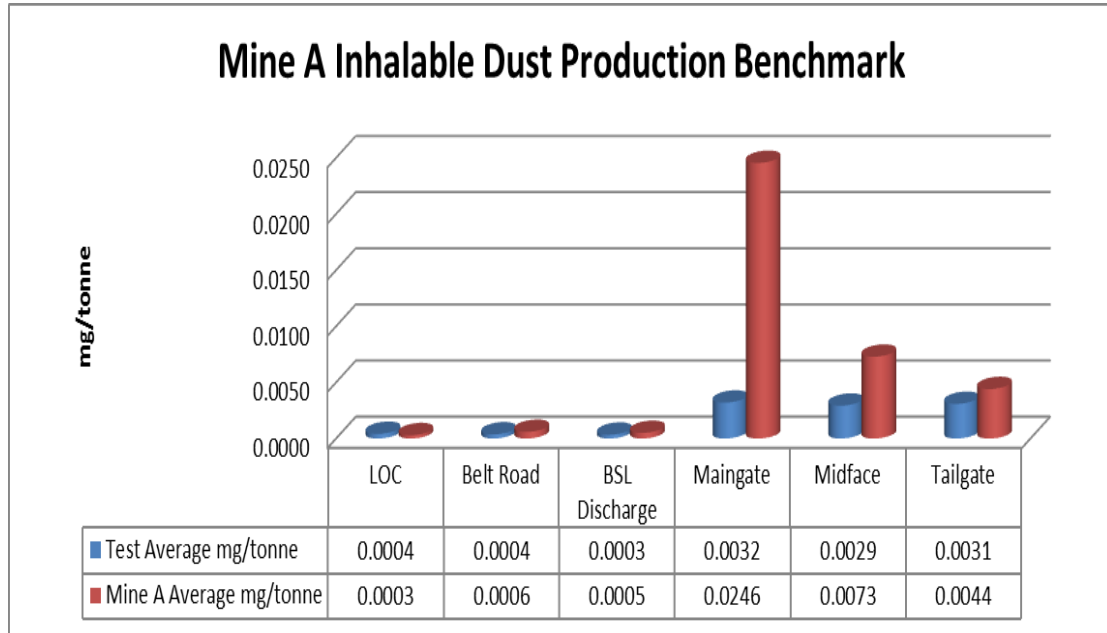


**Figure 8.77 Inhalable Benchmark Dust Load Production Comparative Analysis**

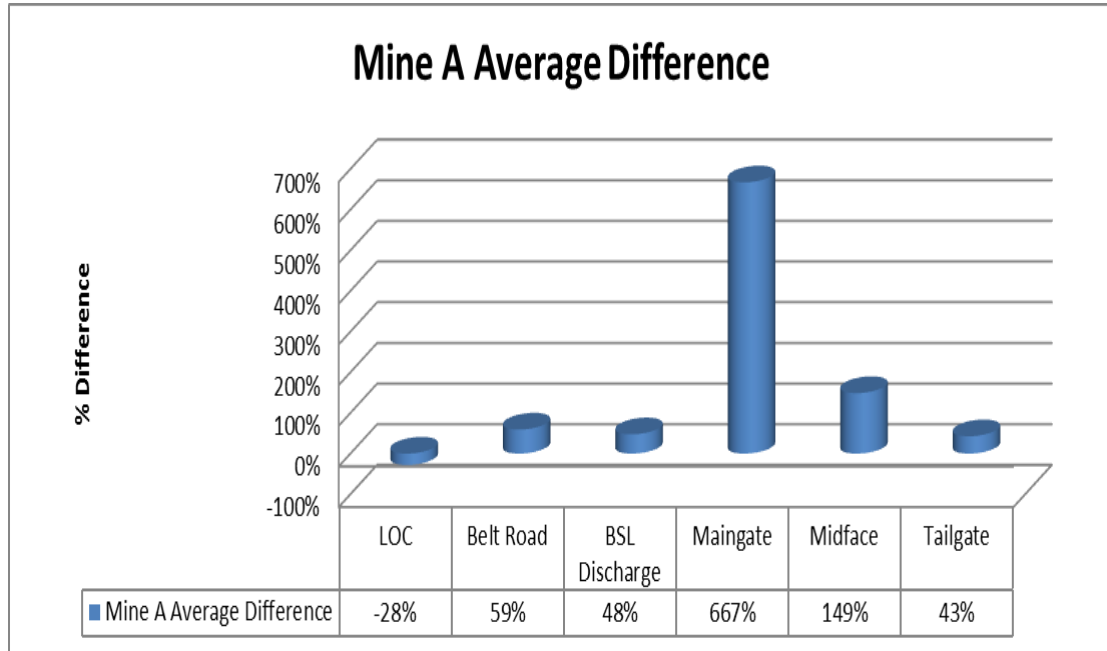
## **8.20 Benchmark Inhalable Dust Load Production Comparative Analysis**

This section analyses the measured inhalable dust loads for each of the identified sources of dust generation and compares each of the 5 mines tested to the overall mine average at those locations. From this analysis, it can be determined which mine produced the least mg/tonne with no installed engineering controls operating and which mine produces the most. This section also identifies the average respirable dust load production from all mines at these independent sources.

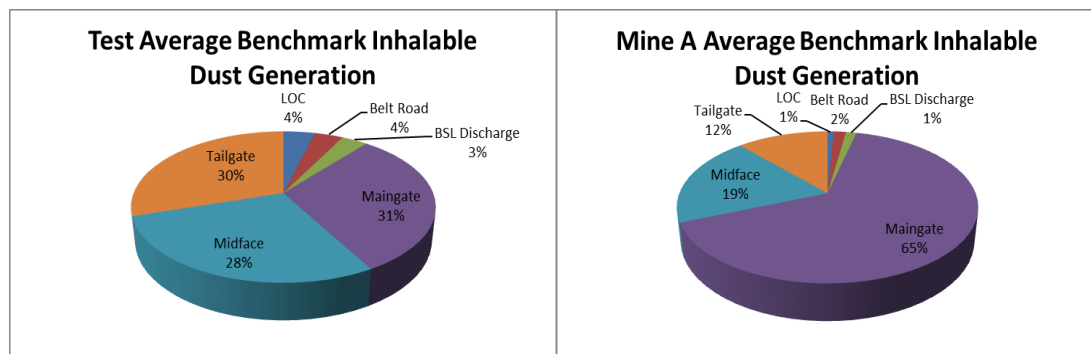
**8.20.1 Mine A Inhalable Dust Load Production Analysis**



**Figure 8.78 Mine A Inhalable Dust Production Benchmark Comparison**



**Figure 8.79 Mine A Average Inhalable Dust Production Difference**



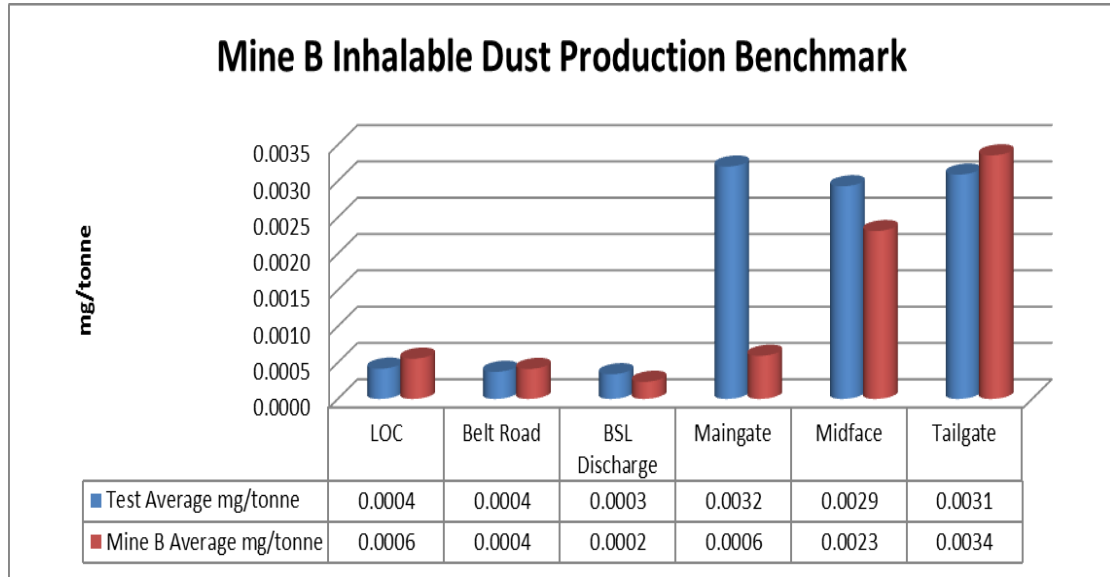
**Figure 8.80 Test Average and Mine A Average Inhalable Benchmark Dust Production**

### 8.20.2 Mine A Inhalable Benchmark Production Discussion

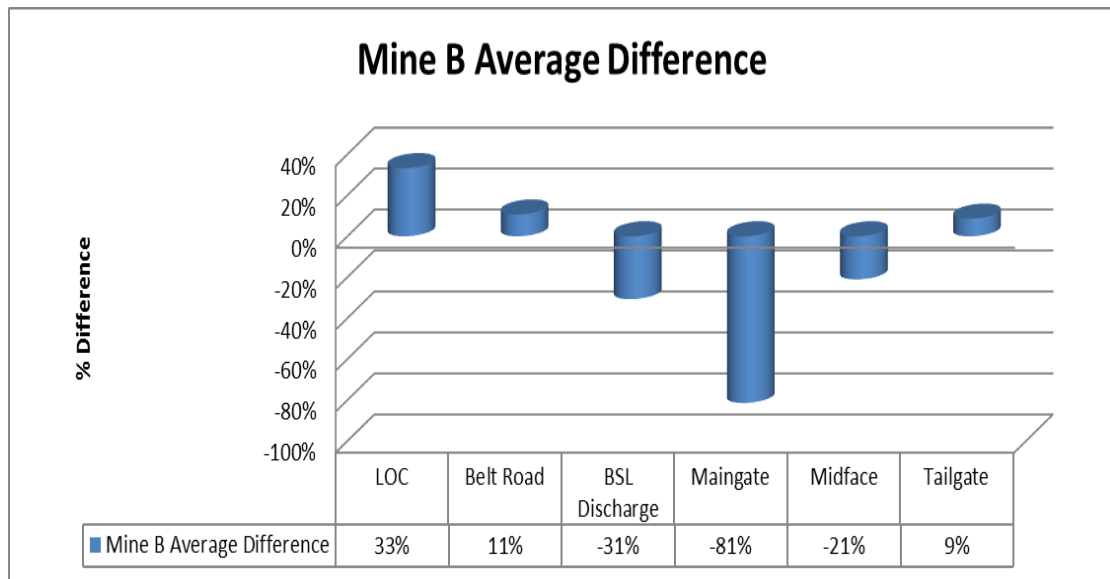
Figure 8.78 details the amount of inhalable dust produced by Mine A during the cutting cycle at each location tested. This is compared to the average inhalable dust produced at the same locations for all mines tested. Figure 8.79 shows that Mine A produced 28% less inhalable dust at the LOC, 59% more at the belt road, 48% more at the BSL discharge, 667% more at the maingate, 149% more midface and 43% more than the average inhalable dust production at the tailgate.

Figure 8.80 shows that the average inhalable benchmark dust production of all mines tested is 4% from the LOC, 4% from the belt road, 3% from the BSL discharge, 31% from the maingate, 28% midface and 30% in the tailgate. Mine A's inhalable benchmark dust production was 1% from the LOC, 2% from the belt road, 1% from the BSL discharge, 65% from the maingate, 19% midface and 12% in the tailgate.

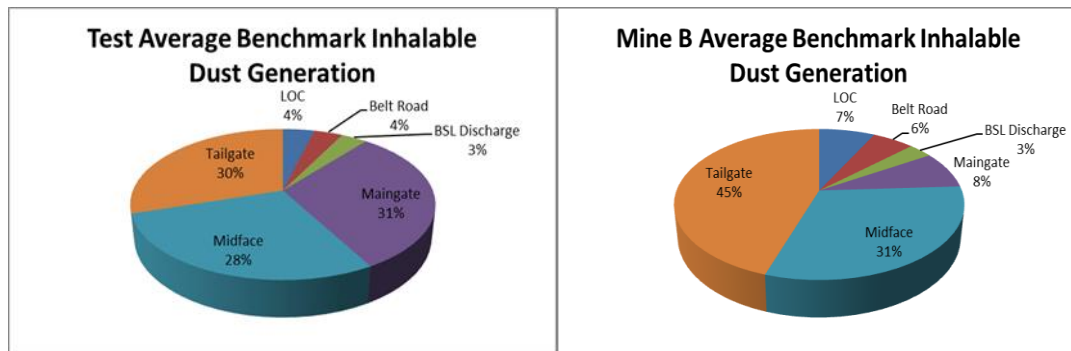
**8.20.3 Mine B Inhalable Dust Load Production Analysis**



**Figure 8.81 Mine B Inhalable Dust Production Benchmark Comparison**



**Figure 8.82 Mine B Average Inhalable Dust Production Difference**



**Figure 8.83 Test Average and Mine B Average Inhalable Benchmark Dust Production**

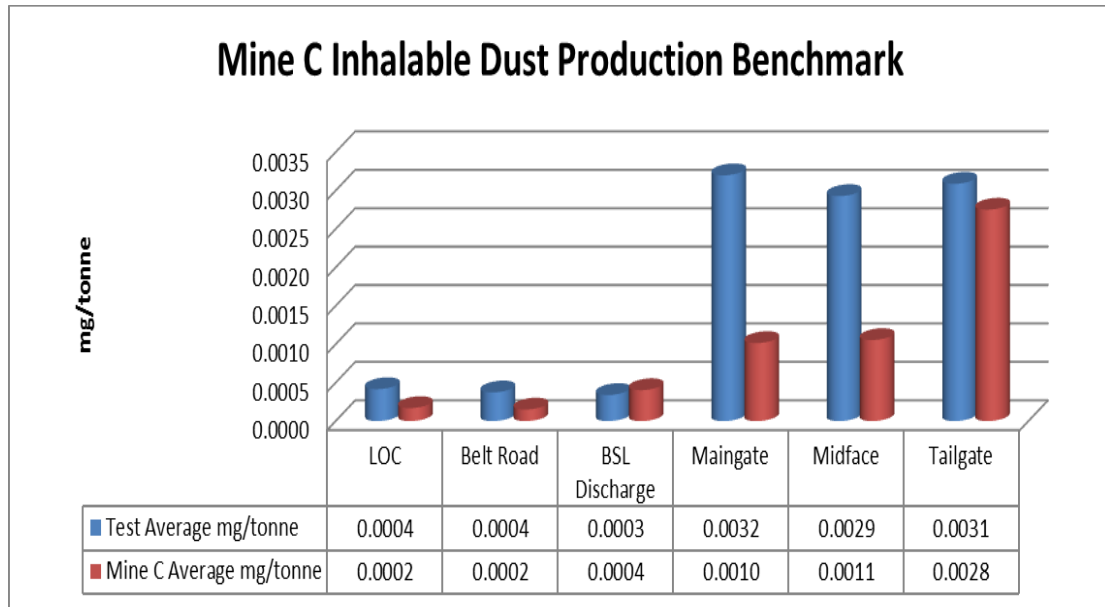
#### **8.20.4 Mine B Inhalable Benchmark Production Discussion**

Figure 8.81 details the amount of inhalable dust produced by Mine B during the cutting cycle at each location tested. This is compared to the average inhalable dust produced at the same locations for all mines tested. Figure 8.82 shows that Mine B produced 33% more inhalable dust at the LOC, 11% more at the belt road, 31% less at the BSL discharge, 81% less at the maingate, 21% less midface and 9% more than the average inhalable dust production at the tailgate.

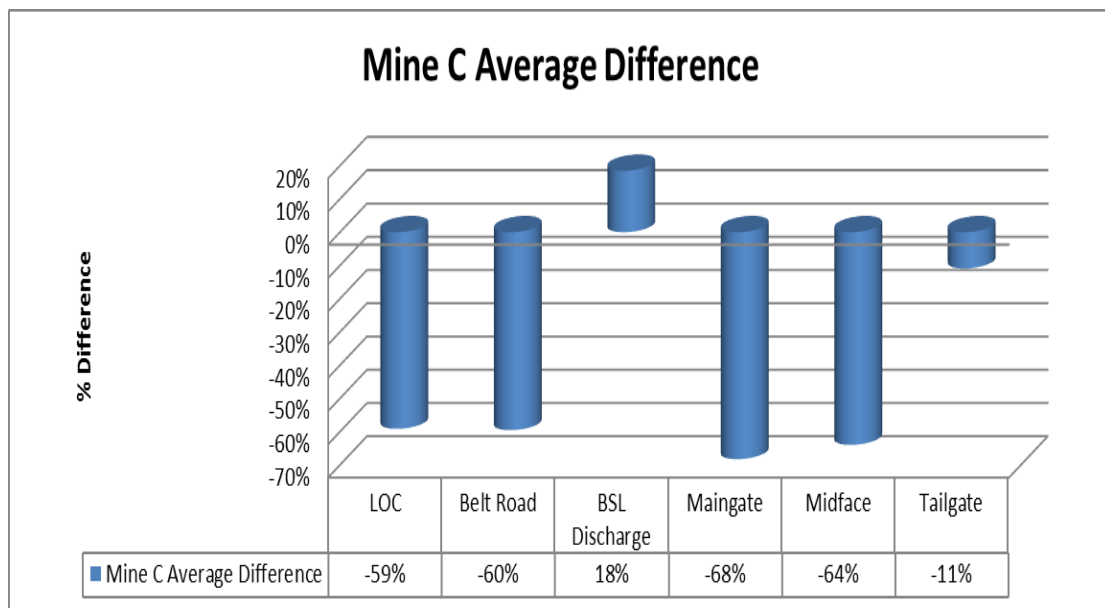
Figure 8.83 shows that the average inhalable benchmark dust production of all mines tested is 4% from the LOC, 4% from the belt road, 3% from the BSL discharge, 31% from the maingate, 28% midface and 30% in the tailgate. Mine B's inhalable benchmark dust production was 7% from the LOC, 6% from the belt road, 3% from the BSL discharge, 8% from the maingate, 31% midface and 45% in the tailgate.



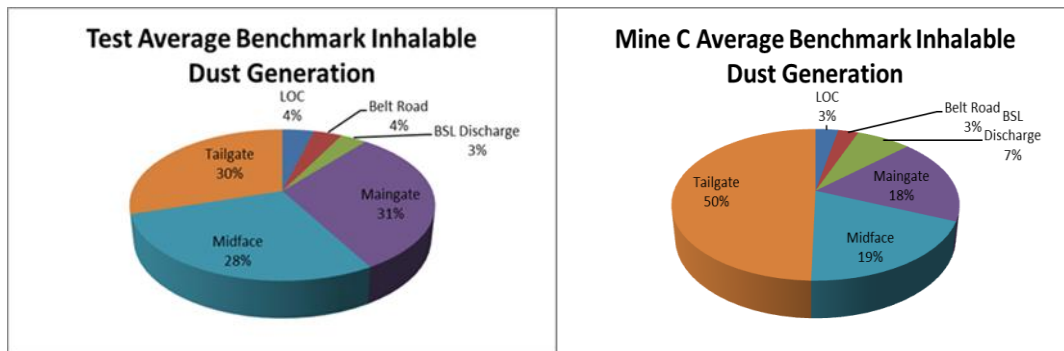
**8.20.5 Mine C Inhalable Dust Load Production Analysis**



**Figure 8.84 Mine C Inhalable Dust Production Benchmark Comparison**



**Figure 8.85 Mine B Average Inhalable Dust Production Difference**



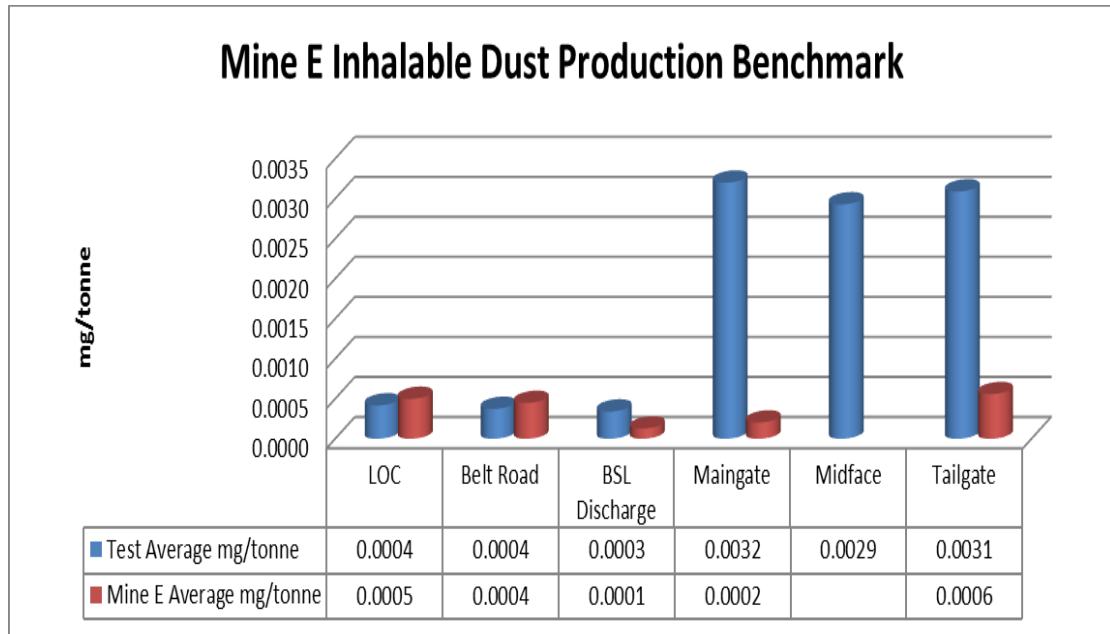
**Figure 8.86 Test Average and Mine C Average Inhalable Benchmark Dust Production**

### 8.20.6 Mine C Inhalable Benchmark Production Discussion

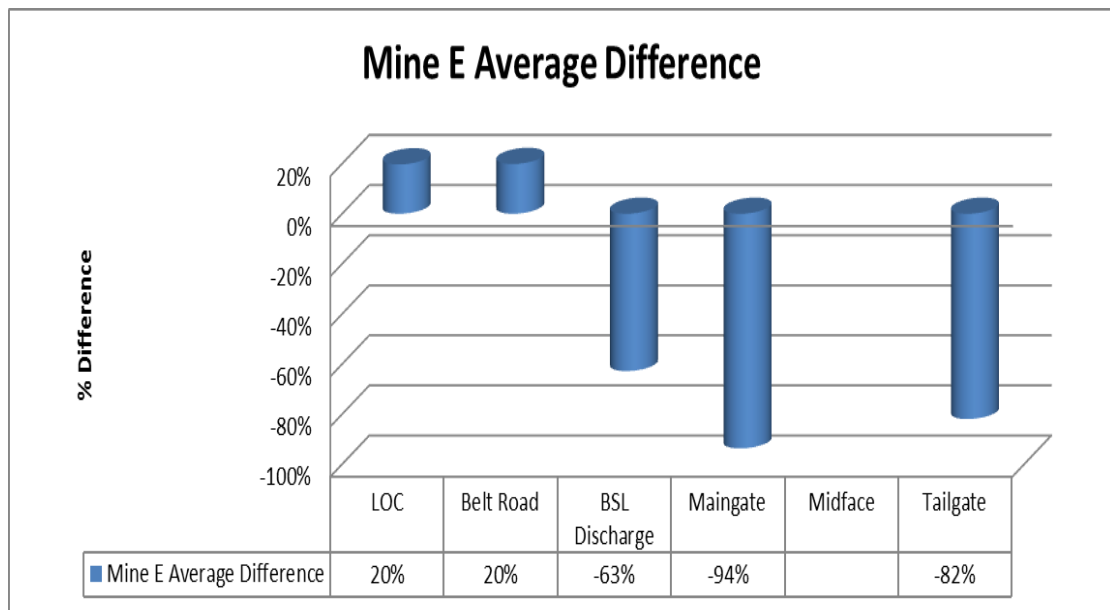
Figure 8.84 details the amount of inhalable dust produced by Mine C during the cutting cycle at each location tested. This is compared to the average inhalable dust produced at the same locations for all mines tested. Figure 8.85 shows that Mine C produced 59% less inhalable dust at the LOC, 60% less at the belt road, 18% more at the BSL discharge, 68% less at the maingate, 64% less midface and 11% less than the average inhalable dust production at the tailgate.

Figure 8.86 shows that the average inhalable benchmark dust production of all mines tested is 4% from the LOC, 4% from the belt road, 3% from the BSL discharge, 31% from the maingate, 28% midface and 30% in the tailgate. Mine B's inhalable benchmark dust production was 3% from the LOC, 3% from the belt road, 7% from the BSL discharge, 18% from the maingate, 19% midface and 50% in the tailgate.

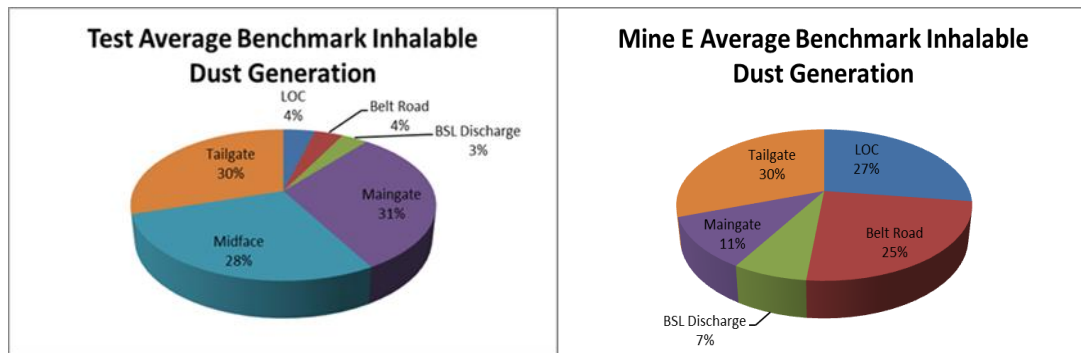
**8.20.7 Mine E Inhalable Dust Load Production Analysis**



**Figure 8.87 Mine E Inhalable Dust Production Benchmark Comparison**



**Figure 8.88 Mine E Average Inhalable Dust Production Difference**



**Figure 8.89 Test Average and Mine E Average Inhalable Benchmark Dust Production**

### 8.20.8 Mine E Inhalable Benchmark Production Discussion

Figure 8.87 details the amount of inhalable dust produced by Mine E during the cutting cycle at each location tested. This is compared to the average inhalable dust produced at the same locations for all mines tested. Figure 8.88 shows that Mine E produced 20% more inhalable dust at the LOC, 20% more at the belt road, 63% less at the BSL discharge, 94% less at the maingate, and 82% less than the average inhalable dust production at the tailgate.

Figure 8.89 shows that the average inhalable benchmark dust production of all mines tested is 4% from the LOC, 4% from the belt road, 3% from the BSL discharge, 31% from the maingate, 28% midface and 30% in the tailgate. Mine E's inhalable benchmark dust production was 27% from the LOC, 25% from the belt road, 7% from the BSL discharge, 11% from the maingate and 30% in the tailgate.

## 8.21 DME Respirable Dust

Of the 190 respirable samples collected, 124 of these were DME samples. DME samples are defined as those samples taken with all installed engineering controls operating. These collected DME samples were analysed at each of the known sources of dust generation and compared to a mine respirable DME average, with this average then underpinning the average respirable DME for each mine sampled, and identifying which mine produces the least mg/tonne of respirable dust during the cutting cycle.

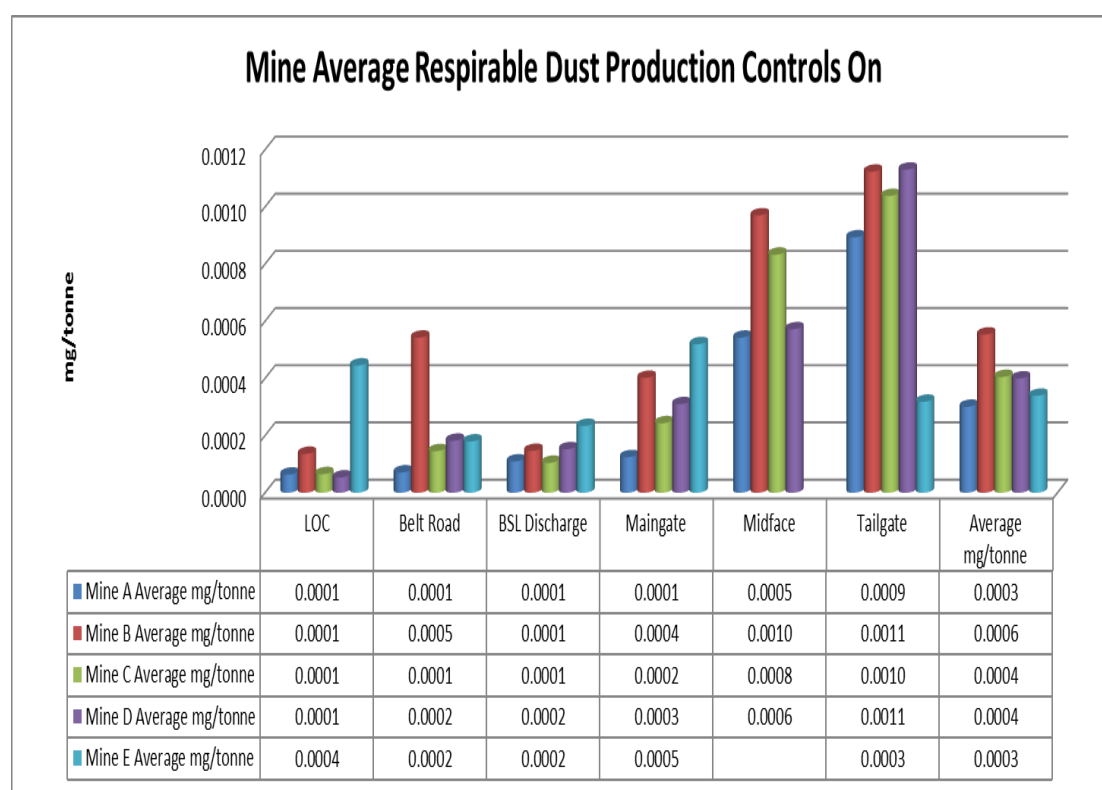
Table 8.23 summarises the collected respirable dust samples undertaken for DME determination. The collected samples have been placed in mine order with the collected samples averaged over the amount of samples taken at the known sources of dust generation. These averages have then been analysed in detail.

**Table 8.23 Respirable DME Samples**

	LOC	Belt Road	BSL Discharge	Maingate	Midface	Tailgate	Average mg/ton
Test 1-Mine A	0.0001	0.0001	0.0001	0.0001	0.0005	0.0009	
Mine A Average mg/tonne	<b>0.0001</b>	<b>0.0001</b>	<b>0.0001</b>	<b>0.0001</b>	<b>0.0005</b>	<b>0.0009</b>	<b>0.0003</b>
Test 2-Mine B	0.0001	0.0014	0.0001	0.0001	0.0006	0.0000	
Test 6-Mine B	0.0002	0.0002	0.0002	0.0002			
Test 7-Mine B				0.0007	0.0012	0.0017	
Test 10-Mine B				0.0007	0.0013	0.0014	
Test 11-Mine B	0.0001	0.0001	0.0001	0.0003	0.0008	0.0013	
Mine B Average mg/tonne	<b>0.0001</b>	<b>0.0005</b>	<b>0.0001</b>	<b>0.0004</b>	<b>0.0010</b>	<b>0.0011</b>	<b>0.0006</b>
Test 3-Mine C	0.0000	0.0001	0.0000	0.0001	0.0008	0.0012	
Test 4-Mine C	0.0001	0.0005	0.0001	0.0001	0.0006	0.0009	
Test 5-Mine C	0.0001	0.0001	0.0002	0.0007	0.0011	0.0015	
Test 13-Mine C	0.0000	0.0000	0.0001	0.0002		0.0008	
Test 14-Mine C	0.0000	0.0000	0.0001	0.0002		0.0009	
Mine C Average mg/tonne	<b>0.0001</b>	<b>0.0001</b>	<b>0.0001</b>	<b>0.0002</b>	<b>0.0008</b>	<b>0.0010</b>	<b>0.0004</b>
Test 8-Mine D	0.0001	0.0004	0.0003	0.0005	0.0010	0.0018	
Test 9-Mine D	0.0001	0.0004	0.0003	0.0006	0.0010	0.0019	
Mine D Average mg/tonne	<b>0.0001</b>	<b>0.0002</b>	<b>0.0002</b>	<b>0.0003</b>	<b>0.0006</b>	<b>0.0011</b>	<b>0.0004</b>
Test 12-Mine E	0.0006	0.0002	0.0004	0.0003		0.0006	
Test 15-Mine E	0.0003	0.0002	0.0001	0.0008		0.0001	
Mine E Average mg/tonne	<b>0.0004</b>	<b>0.0002</b>	<b>0.0002</b>	<b>0.0005</b>		<b>0.0003</b>	<b>0.0003</b>

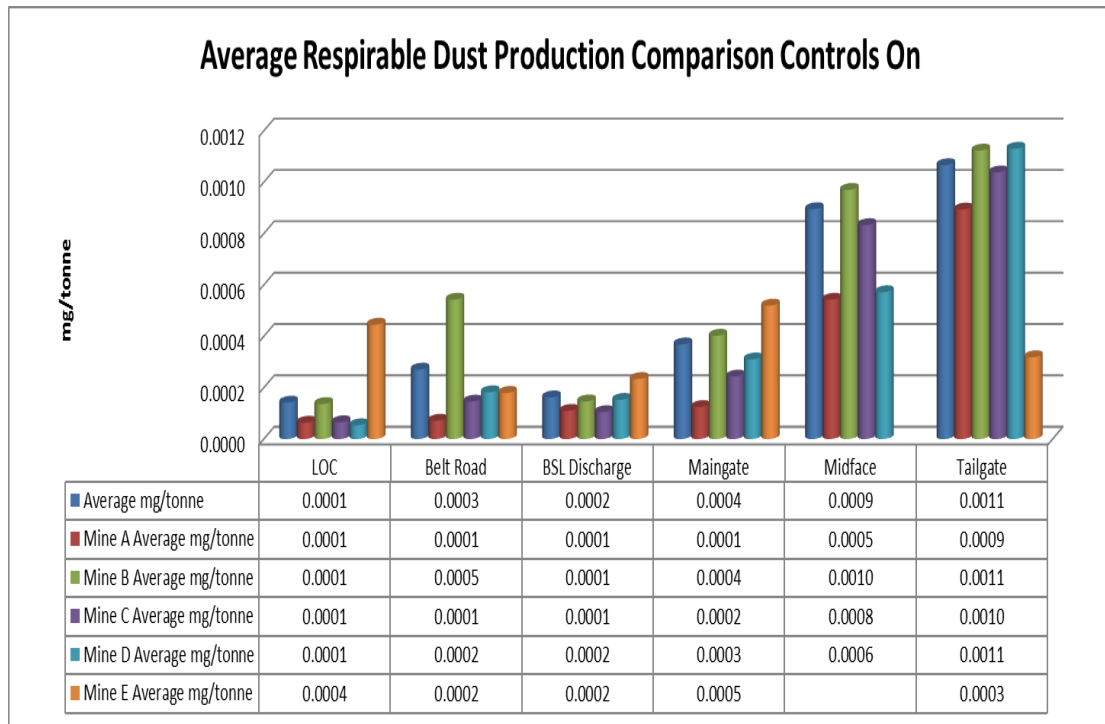
**CHAPTER EIGHT**  
Data Analysis and Discussion

Figure 8.90 details the average mg/tonne of respirable dust produced during the cutting cycle with no engineering controls operating at each of the known sources of dust generation for each of the mines sampled. The average mg/tonne was calculated by adding together each of the collected samples and dividing the number by the amount of samples collected. This average was then used to compare the average of each sample collected at that location for each of the 15 tests undertaken at the 5 mines and is detailed in Figure 8.91, with Figure 8.92 showing the percentage difference that each mine obtained compared to the overall mine average.

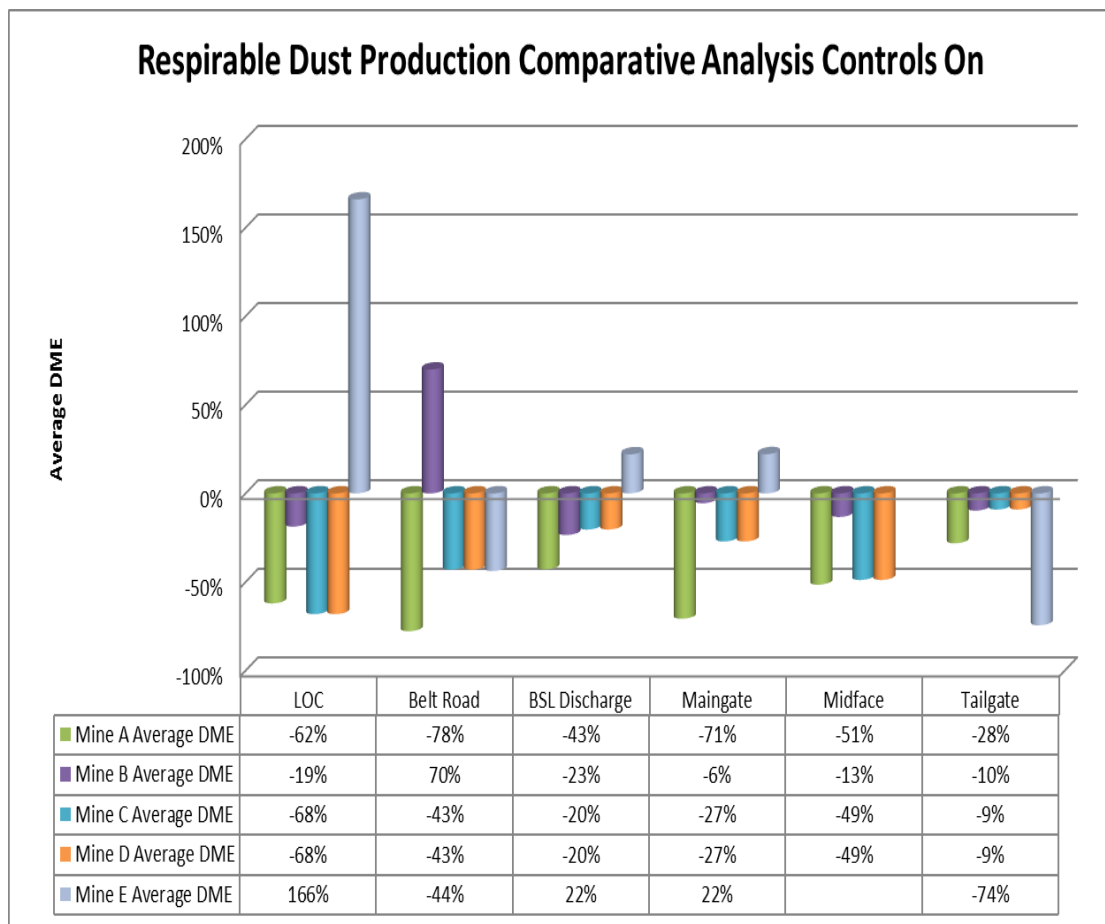


**Figure 8.90 Mine Average Respirable Dust Production Controls On**

**CHAPTER EIGHT**  
Data Analysis and Discussion



**Figure 8.91 Average Respirable Dust Production Comparison Controls On**

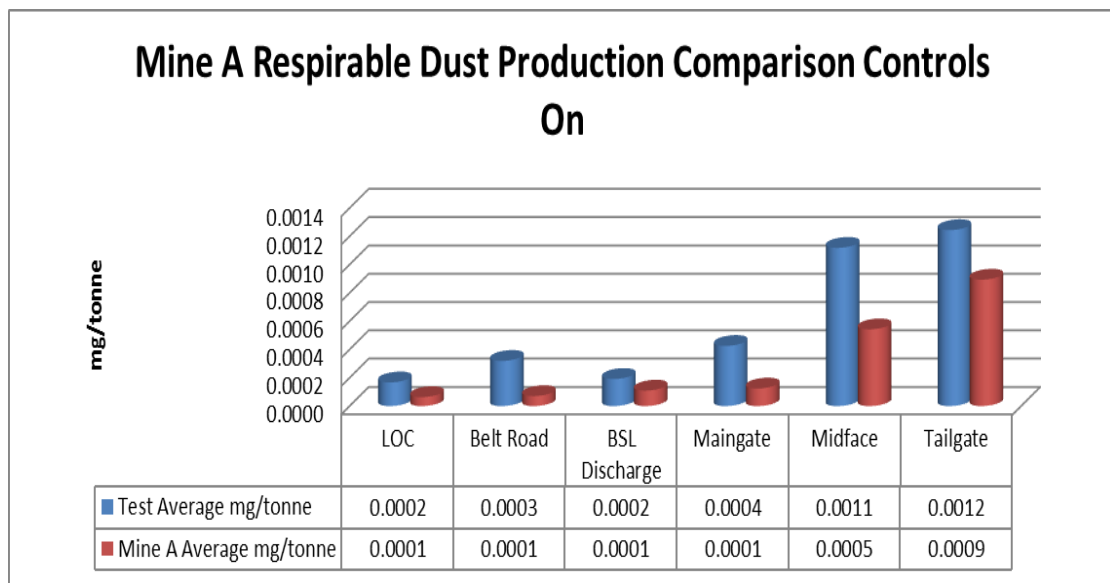


**Figure 8.92 Respirable Average DME Comparative Analysis**

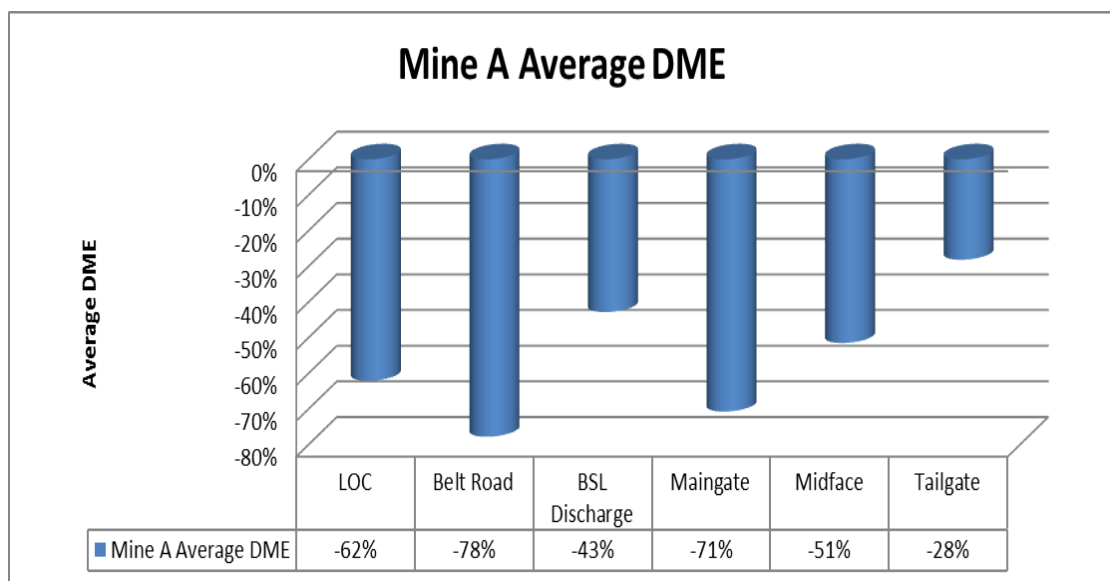
## 8.22 Respirable DME Comparative Analysis

This section analyses the measured respirable DME for each of the identified sources of dust generation and compares each of the 5 mines tested to the overall mine average at those locations. From this analysis, it can be determined which mine has the highest DME for installed engineering controls.

### 8.22.1 Mine A Respirable Dust Load Production Analysis

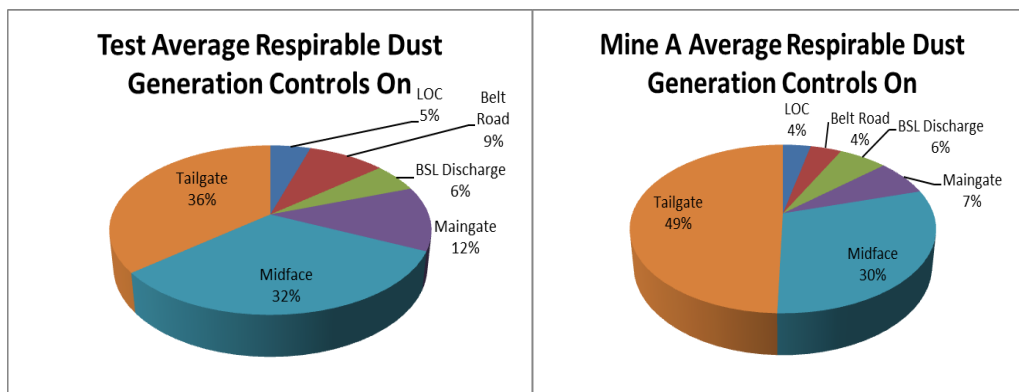


**Figure 8.93 Mine A Respirable Dust Production Comparison Controls On**



**Figure 8.94 Mine A Average Respirable DME**





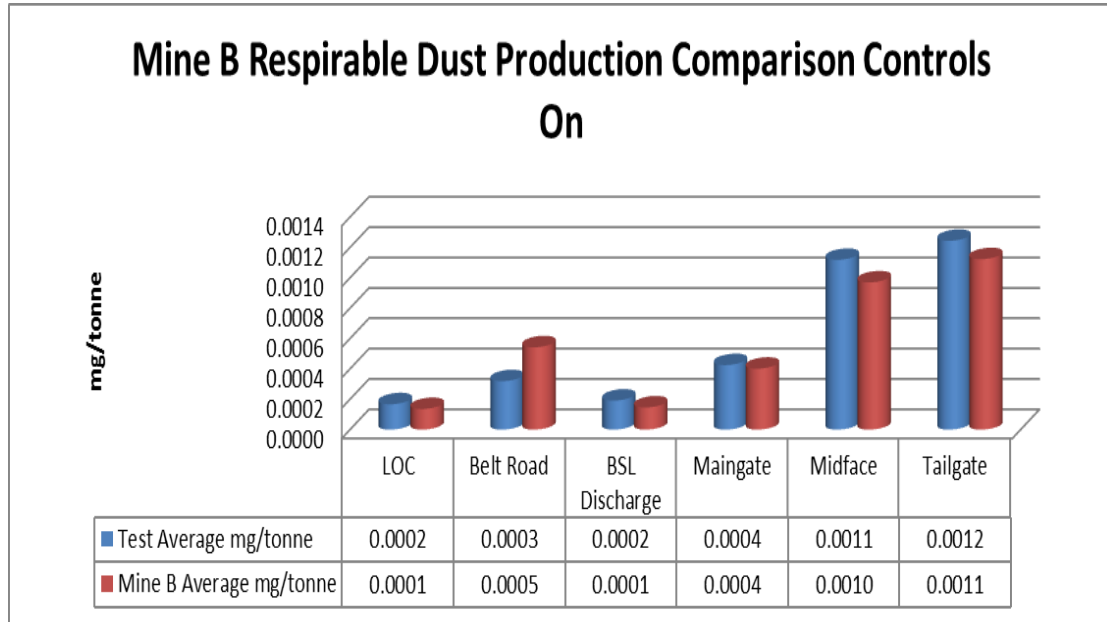
**Figure 8.95 Test Average and Mine A Average Respirable Dust Production Controls On**

### **8.22.2 Mine A Respirable Dust Production Discussion Controls On**

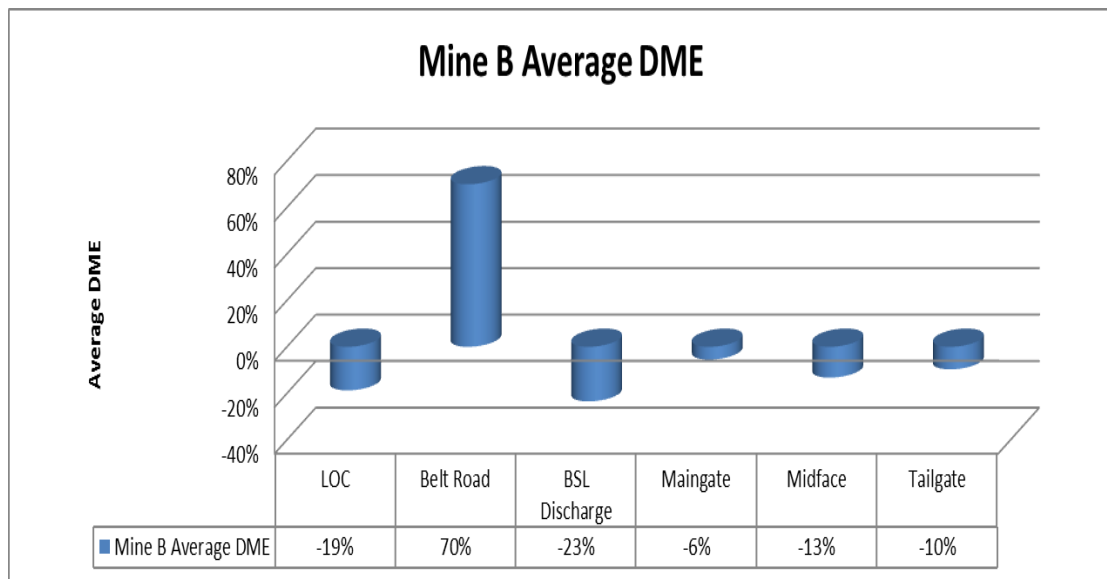
Figure 8.93 details the amount of respirable dust produced by Mine A during the cutting cycle at each location tested. This is compared to the average respirable dust produced at the same locations for all mines tested. Figure 8.94 shows that Mine A, with installed engineering controls operating, produced 62% less respirable dust at the LOC, 78% less at the belt road, 43% less at the BSL discharge, 71% less at the maingate, 51% less midface and 28% less than the average respirable dust production at the tailgate.

Figure 8.95 shows that the average respirable DME of all mines tested is 5% from the LOC, 9% from the belt road, 6% from the BSL discharge, 12% from the maingate, 32% midface and 36% in the tailgate. Mine A's respirable DME was 4% from the LOC, 4% from the belt road, 6% from the BSL discharge, 7% from the maingate, 30% midface and 49% in the tailgate.

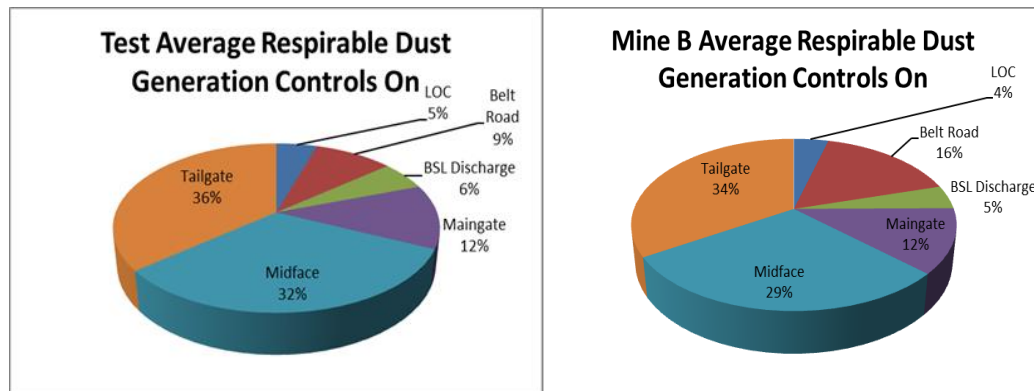
**8.22.3 Mine B Respirable Dust Load Production Analysis**



**Figure 8.96 Mine B Respirable Dust Production Comparison Controls On**



**Figure 8.97 Mine B Average Respirable DME**



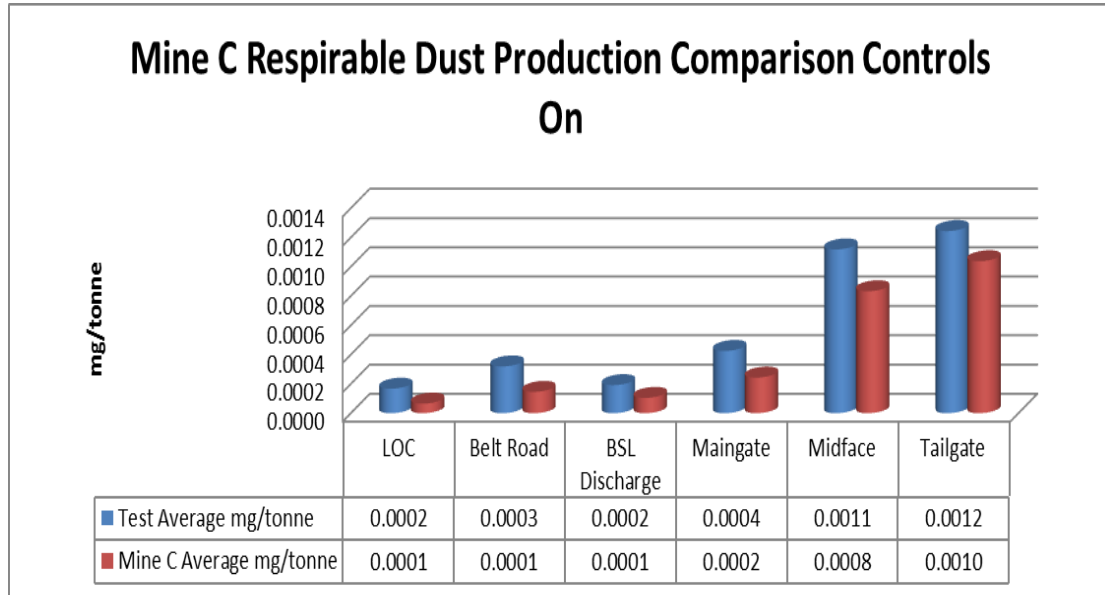
**Figure 8.98 Test Average and Mine B Average Respirable Dust Production Controls On**

#### **8.22.4 Mine B Respirable Dust Production Discussion Controls On**

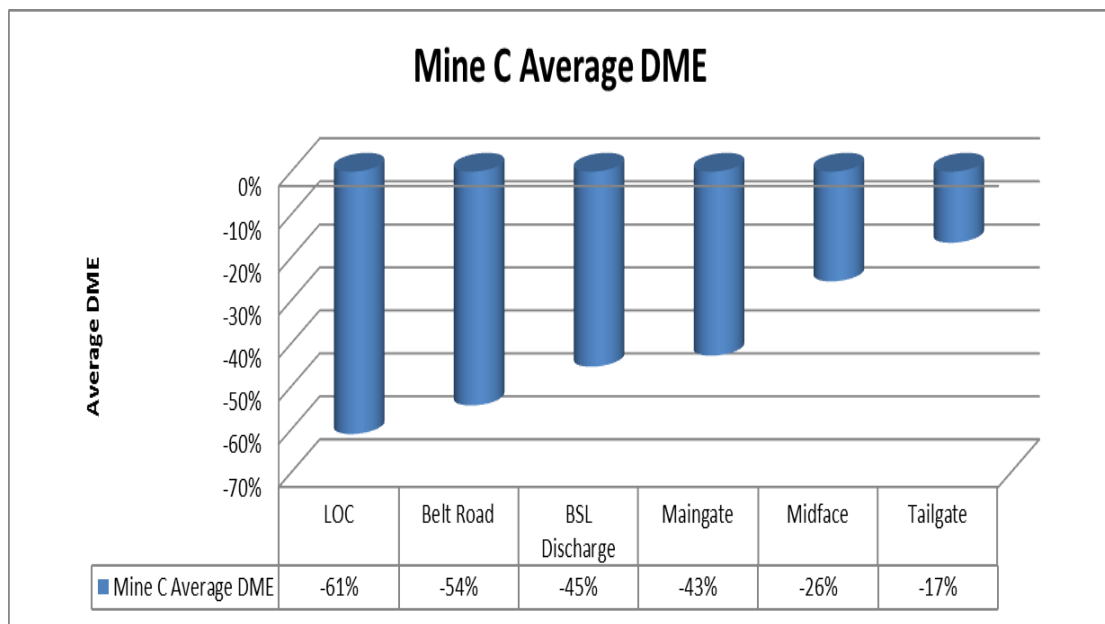
Figure 8.86 details the amount of respirable dust produced by Mine B during the cutting cycle at each location tested. This is compared to the average respirable dust produced at the same locations for all mines tested. Figure 8.87 shows that Mine B, with installed engineering controls operating, produced 19% less respirable dust at the LOC, 70% more at the belt road, 23% less at the BSL discharge, 6% less at the maingate, 13% less midface and 10% less than the average respirable dust production at the tailgate.

Figure 8.88 shows that the average respirable dust production with installed engineering controls operating of all mines tested is 5% from the LOC, 9% from the belt road, 6% from the BSL discharge, 12% from the maingate, 32% midface and 36% in the tailgate. Mine B's respirable dust production with installed engineering controls operating was 4% from the LOC, 16% from the belt road, 5% from the BSL discharge, 12% from the maingate, 29% midface and 34% in the tailgate.

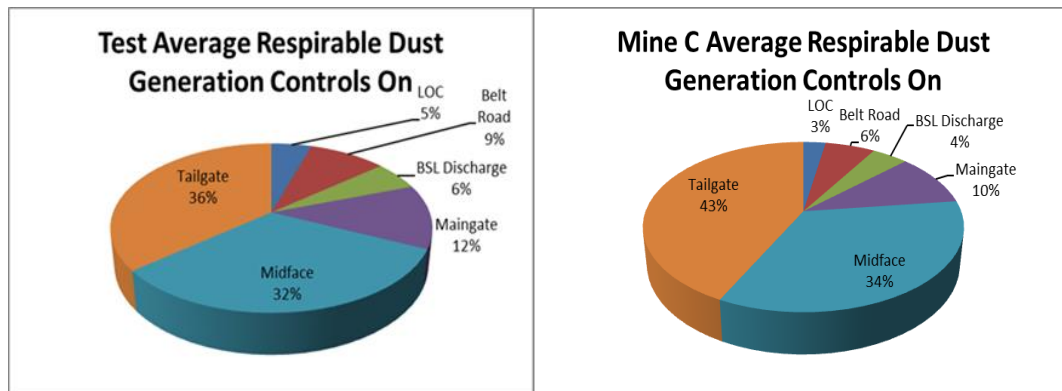
**8.22.5 Mine C Respirable Dust Load Production Analysis**



**Figure 8.99 Mine C Respirable Dust Production Comparison Controls On**



**Figure 8.100 Mine B Average Respirable DME**



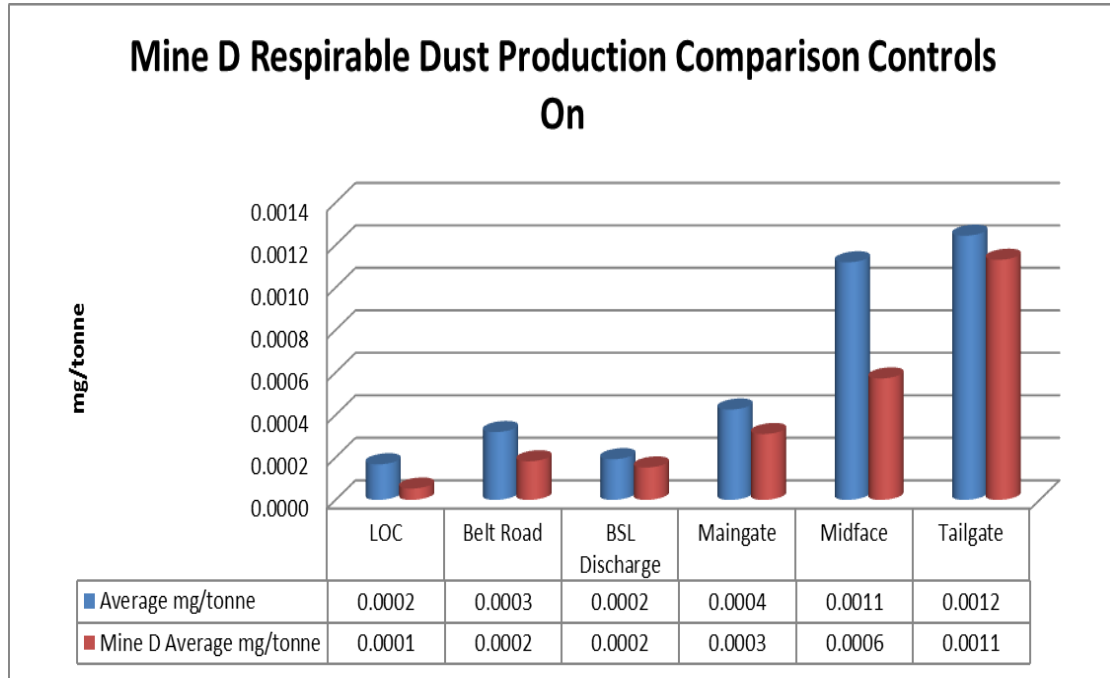
**Figure 8.101 Test Average and Mine C Average Respirable Dust Production Controls On**

### **8.22.6 Mine C Respirable Dust Production Discussion Controls On**

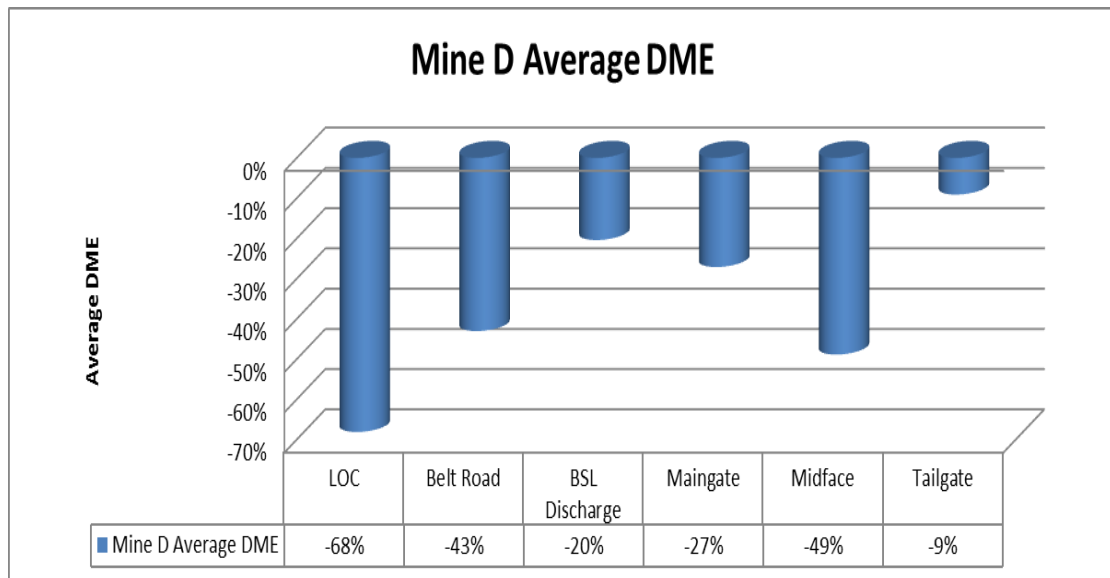
Figure 8.99 details the amount of respirable dust produced by Mine C during the cutting cycle at each location tested. This is compared to the average respirable dust produced at the same locations for all mines tested. Figure 8.100 shows that Mine C, with installed engineering controls operating, produced 61% less respirable dust at the LOC, 54% less at the belt road, 45% less at the BSL discharge, 43% less at the maingate, 26% less midface and 17% less than the average respirable dust production at the tailgate.

Figure 8.101 shows that the average respirable dust production with installed engineering controls operating of all mines tested is 5% from the LOC, 9% from the belt road, 6% from the BSL discharge, 12% from the maingate, 32% midface and 36% in the tailgate. Mine C's respirable dust production with installed engineering controls operating was 3% from the LOC, 6% from the belt road, 4% from the BSL discharge, 10% from the maingate, 34% midface and 43% in the tailgate.

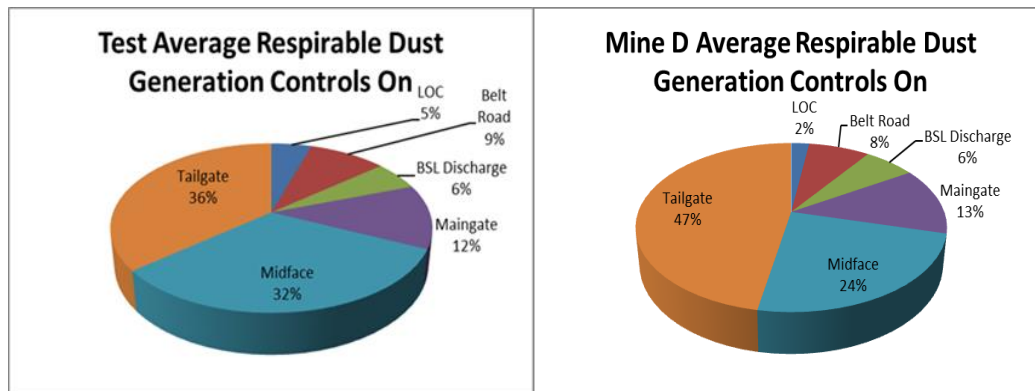
**8.22.7 Mine D Respirable Dust Load Production Analysis**



**Figure 8.102 Mine D Respirable Dust Production Comparison Controls On**



**Figure 8.103 Mine D Average Respirable DME**



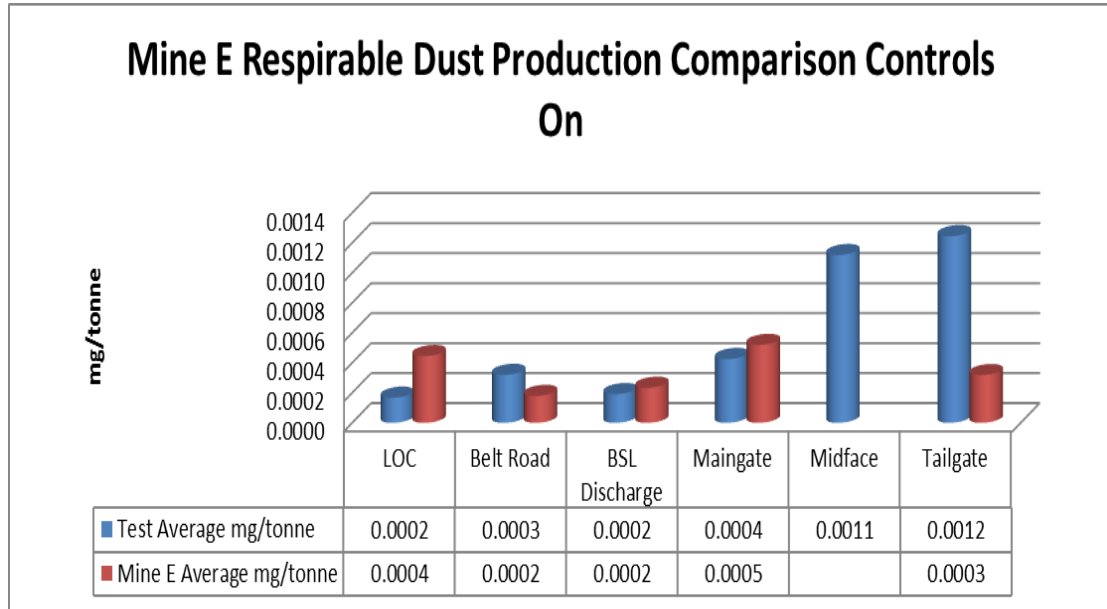
**Figure 8.104 Test Average and Mine D Average Respirable Dust Production Generation Controls On**

### 8.22.8 Mine D Respirable Dust Production Discussion Controls On

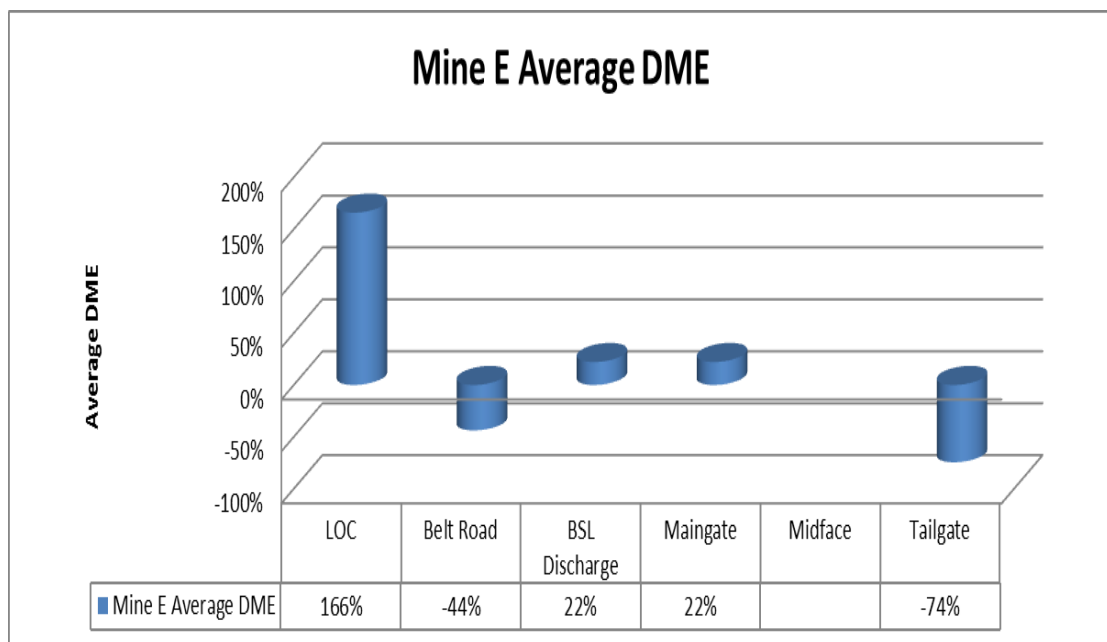
Figure 8.102 details the amount of respirable dust produced by Mine D during the cutting cycle at each location tested. This is compared to the average respirable dust produced at the same locations for all mines tested. Figure 8.103 shows that Mine D, with installed engineering controls operating, produced 68% less respirable dust at the LOC, 43% less at the belt road, 20% less at the BSL discharge, 27% less at the maingate, 49% less midface and 9% less than the average respirable dust production at the tailgate.

Figure 8.104 shows that the average respirable dust production with installed engineering controls operating of all mines tested is 5% from the LOC, 9% from the belt road, 6% from the BSL discharge, 12% from the maingate, 32% midface and 36% in the tailgate. Mine D's respirable dust production with installed engineering controls operating was 2% from the LOC, 8% from the belt road, 6% from the BSL discharge, 13% from the maingate, 24% midface and 47% in the tailgate.

**8.22.9 Mine E Respirable Dust Load Production Analysis**

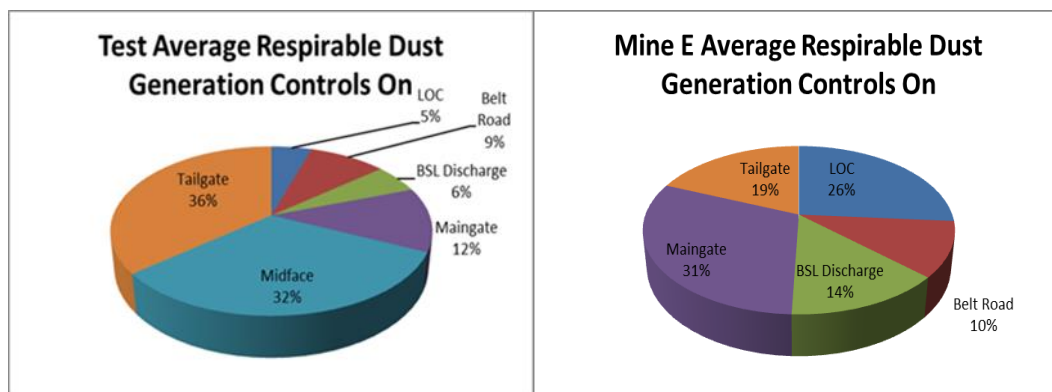


**Figure 8.105 Mine E Respirable Dust Production Comparison Controls On**



**Figure 8.106 Mine E Average Respirable DME**





**Figure 8.107 Test Average and Mine E Average Respirable Dust Production Controls On**

### 8.22.10 Mine E Respirable Dust Production Discussion Controls On

Figure 8.105 details the amount of respirable dust produced by Mine E during the cutting cycle at each location tested. This is compared to the average respirable dust produced at the same locations for all mines tested. Figure 8.106 shows that Mine E, with installed engineering controls operating, produced 166% more respirable dust at the LOC, 44% less at the belt road, 22% more at the BSL discharge, 22% more at the maingate and 74% less than the average respirable dust production at the tailgate.

Figure 8.107 shows that the average respirable dust production with installed engineering controls operating of all mines tested is 5% from the LOC, 9% from the belt road, 6% from the BSL discharge, 12% from the maingate, 32% midface and 36% in the tailgate. Mine E's respirable dust production with installed engineering controls operating was 26% from the LOC, 10% from the belt road, 14% from the BSL discharge, 31% from the maingate, and 19% in the tailgate.

### 8.23 DME Inhalable Dust

Of the 170 inhalable samples collected, 104 of these were DME samples. DME samples are defined as those samples taken with all installed engineering controls operating. These collected DME samples were analysed at each of the known sources of dust generation and compared to a mine inhalable DME average, with this average then underpinning the average DME for each mine sampled, and identifying which mine produces the least mg/tonne of inhalable dust during the cutting cycle. It should be noted that no inhalable samples were taken at Mine D.

Table 8.24 summarises the collected inhalable dust samples undertaken for DME determination. The collected samples have been placed in mine order with the collected samples averaged over the amount of samples taken at the known sources of dust generation. These averages have then been analysed in detail.

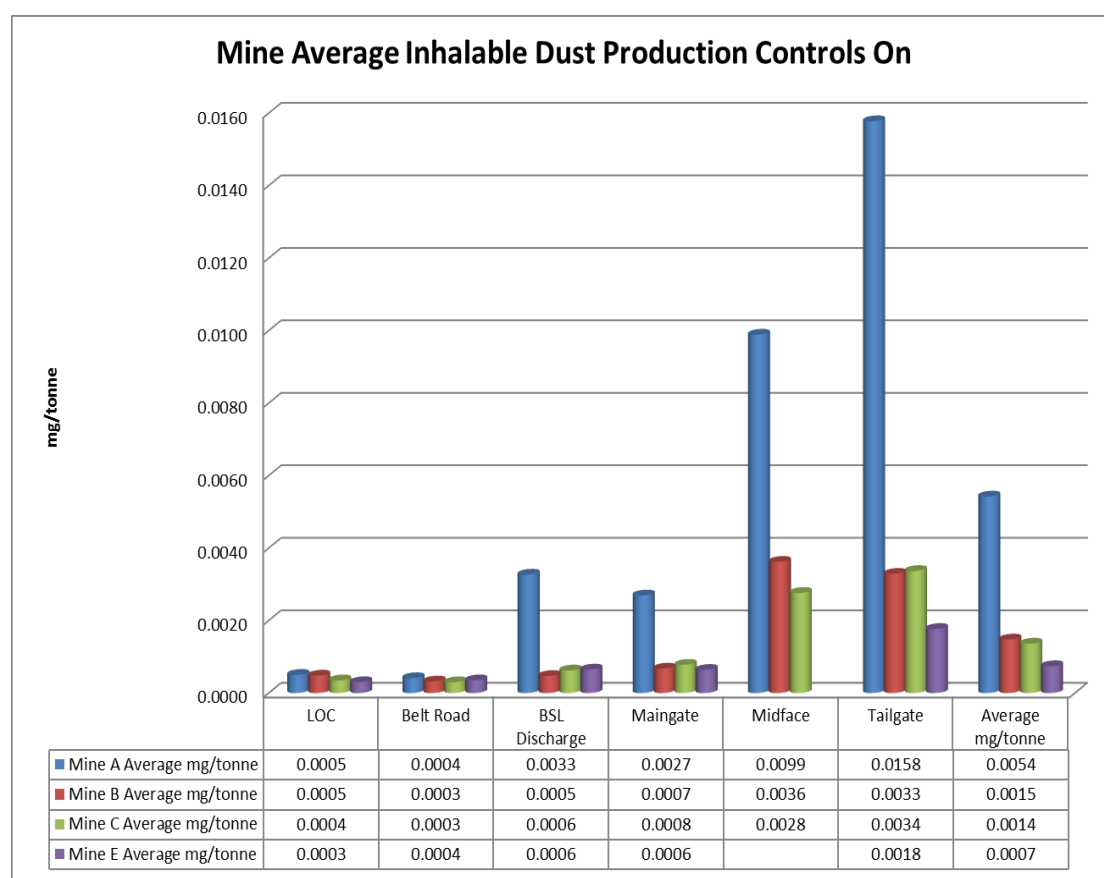
**Table 8.24 Inhalable Dust Production DME Samples**

	LOC	Belt Road	BSL Discharge	Maingate	Midface	Tailgate	Average mg/tonne
Test 1-Mine A	0.0005	0.0004	0.0033	0.0027	0.0099	0.0158	
Mine A Average mg/tonne	<b>0.0005</b>	<b>0.0004</b>	<b>0.0033</b>	<b>0.0027</b>	<b>0.0099</b>	<b>0.0158</b>	<b>0.0054</b>
Test 2-Mine B	0.0002	0.0002	0.0003	0.0003	0.0082	0.0056	
Test 6-Mine B	0.0010	0.0004	0.0007	0.0003			
Test 7-Mine B				0.0011	0.0039	0.0041	
Test 10-Mine B				0.0010	0.0012	0.0021	
Test 11-Mine B	0.0002	0.0003	0.0004	0.0007	0.0013	0.0014	
Mine B Average mg/tonne	<b>0.0005</b>	<b>0.0003</b>	<b>0.0005</b>	<b>0.0007</b>	<b>0.0036</b>	<b>0.0033</b>	<b>0.0015</b>
Test 3-Mine C	0.0004	0.0002	0.0004	0.0006	0.0040	0.0032	
Test 4-Mine C	0.0004	0.0005	0.0005	0.0010	0.0022	0.0049	
Test 5-Mine C	0.0008	0.0006	0.0014	0.0014	0.0021	0.0025	
Test 13-Mine C	0.0001	0.0001	0.0005	0.0005			
Test 14-Mine C	0.0001	0.0001	0.0004	0.0004		0.0028	
Mine C Average mg/tonne	<b>0.0004</b>	<b>0.0003</b>	<b>0.0006</b>	<b>0.0008</b>	<b>0.0028</b>	<b>0.0034</b>	<b>0.0014</b>
Test 8-Mine D							
Test 9-Mine D							
Mine D Average mg/tonne							
Test 12-Mine E	0.0005	0.0002	0.0006	0.0008		0.0009	
Test 15-Mine E	0.0001	0.0005	0.0007	0.0005		0.0027	
Mine E Average mg/tonne	<b>0.0003</b>	<b>0.0004</b>	<b>0.0006</b>	<b>0.0006</b>		<b>0.0018</b>	<b>0.0007</b>

## CHAPTER EIGHT

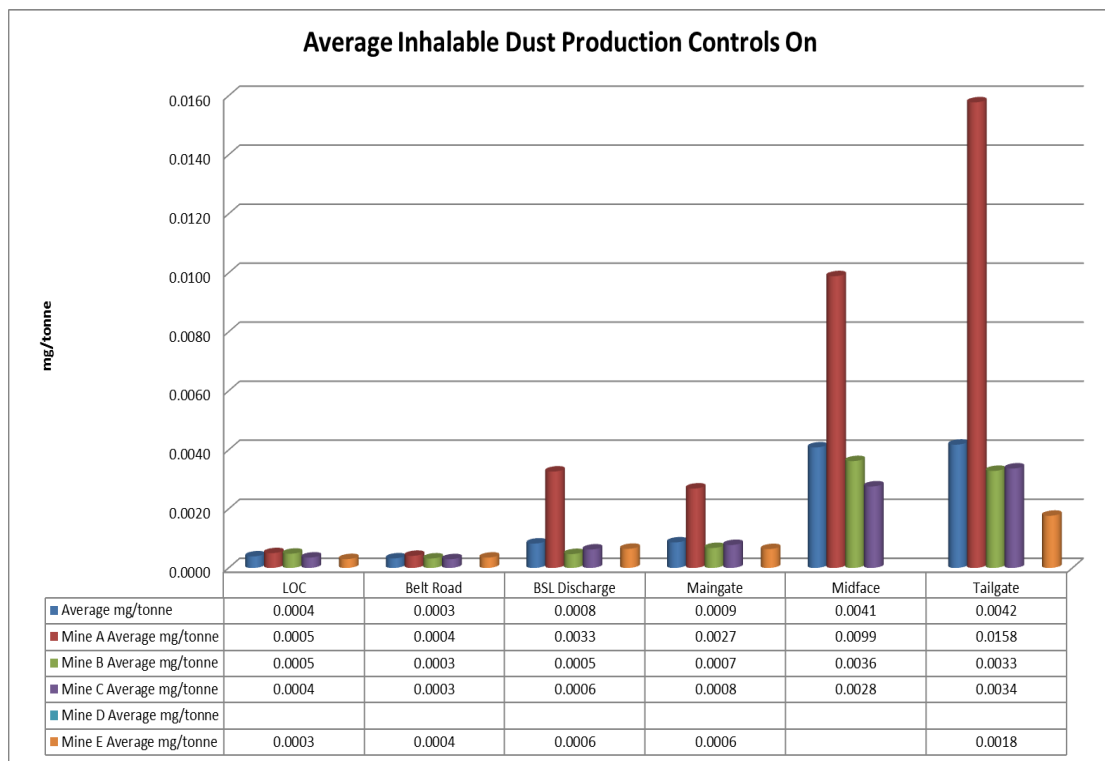
### Data Analysis and Discussion

Figure 8.108 details the average mg/tonne of respirable dust produced during the cutting cycle with no engineering controls operating at each of the known sources of dust generation for each of the mines sampled. The average mg/tonne was calculated by adding together each of the collected samples and dividing the number by the amount of samples collected. This average was then used to compare the average of each sample collected at that location for each of the 15 tests undertaken at the 5 mines and is detailed in Figure 8.109, with Figure 8.110 showing the percentage difference that each mine obtained compared to the overall mine average.

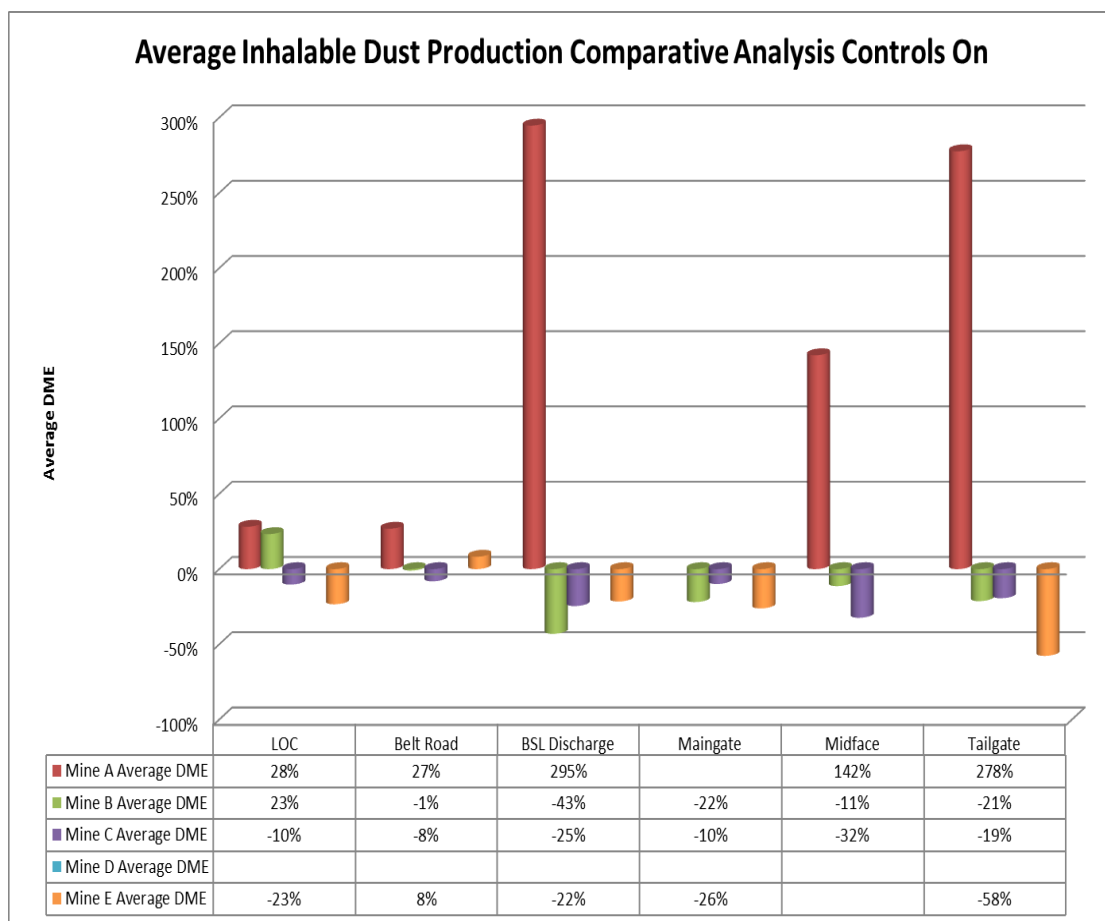


**Figure 8.108 Mine Average Inhalable Dust Production Controls On**

**CHAPTER EIGHT**  
Data Analysis and Discussion



**Figure 8.109 Average Inhalable Benchmark Dust Production Comparison**

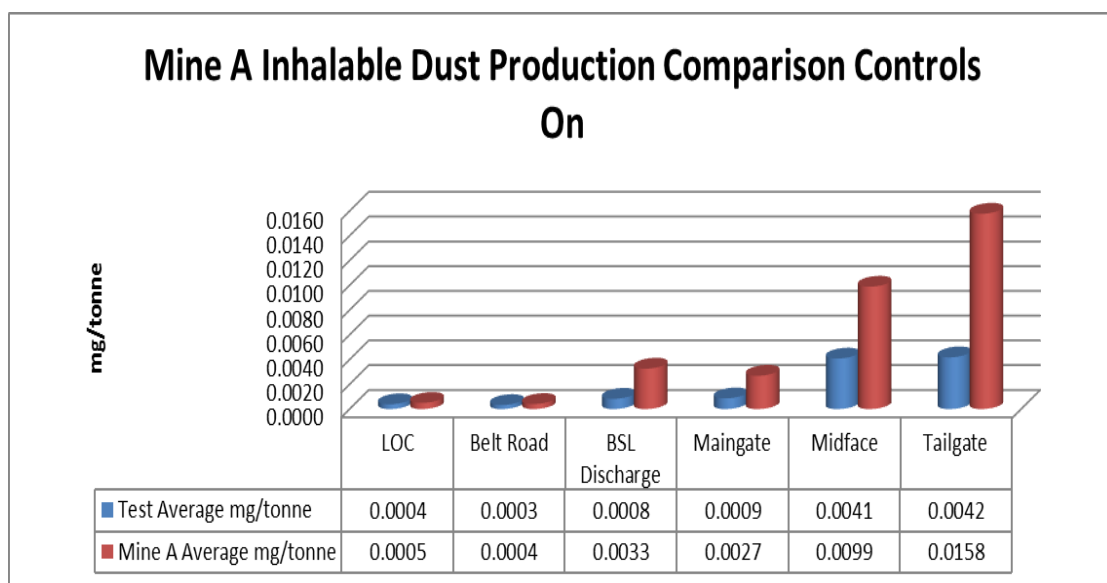


**Figure 8.110 Inhalable Average DME Comparative Analysis**

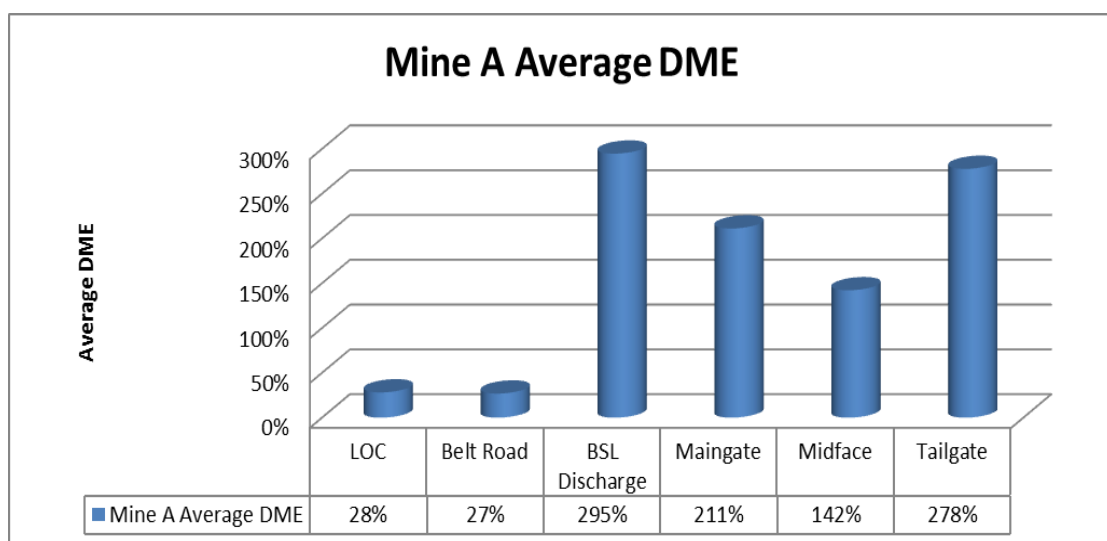
## 8.24 Inhalable DME Comparative Analysis

This section analyses the measured inhalable dust loads for each of the identified sources of dust generation and compares each of the 5 mines tested to the overall mine average at those locations. From this analysis, it can be determined which mine produced the least mg/tonne with installed engineering controls operating.

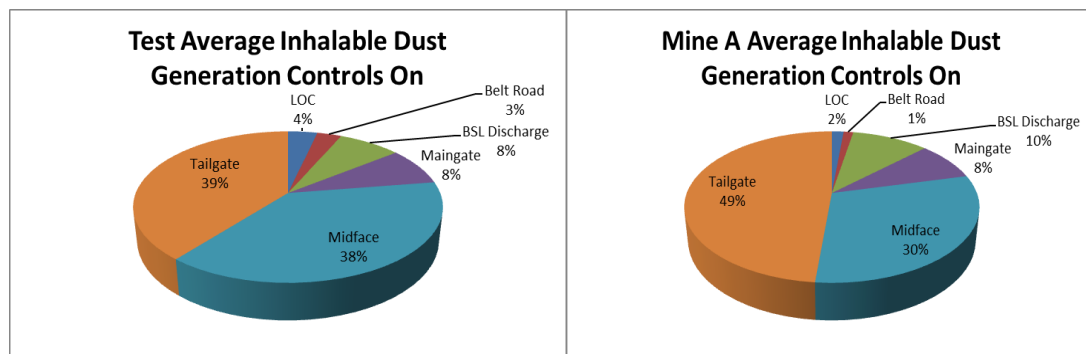
### 8.24.1 Mine A Inhalable Dust Load Production Analysis



**Figure 8.111 Mine A Inhalable Dust Production Comparison Controls On**



**Figure 8.112 Mine A Average Inhalable DME**



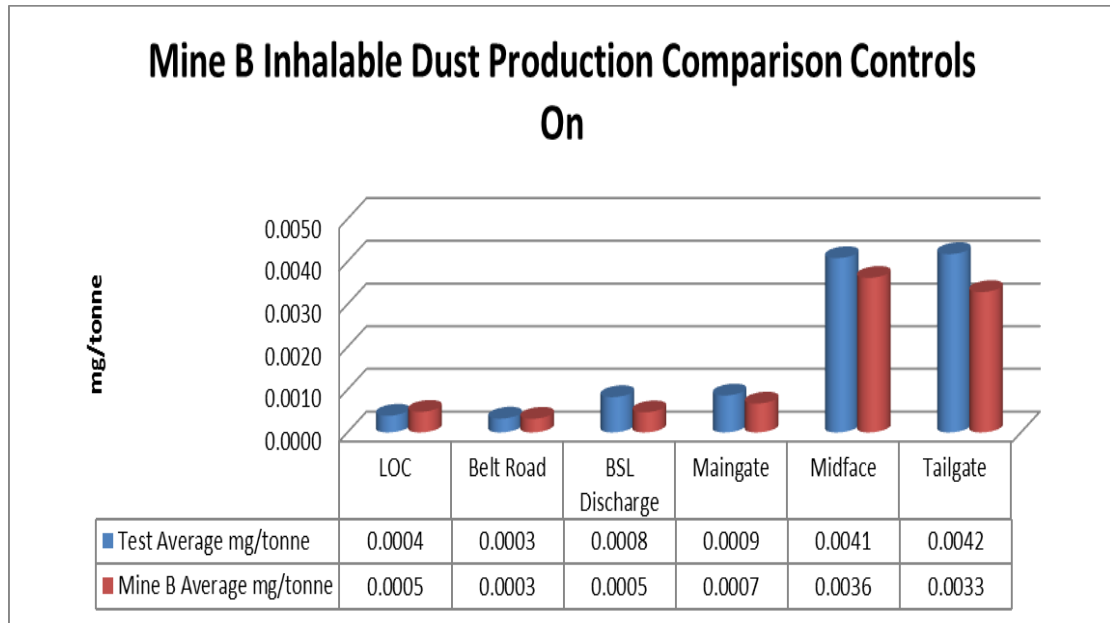
**Figure 8.113 Test Average and Mine A Average Inhalable Dust Production Controls On**

### 8.24.2 Mine A Inhalable Dust Production Discussion

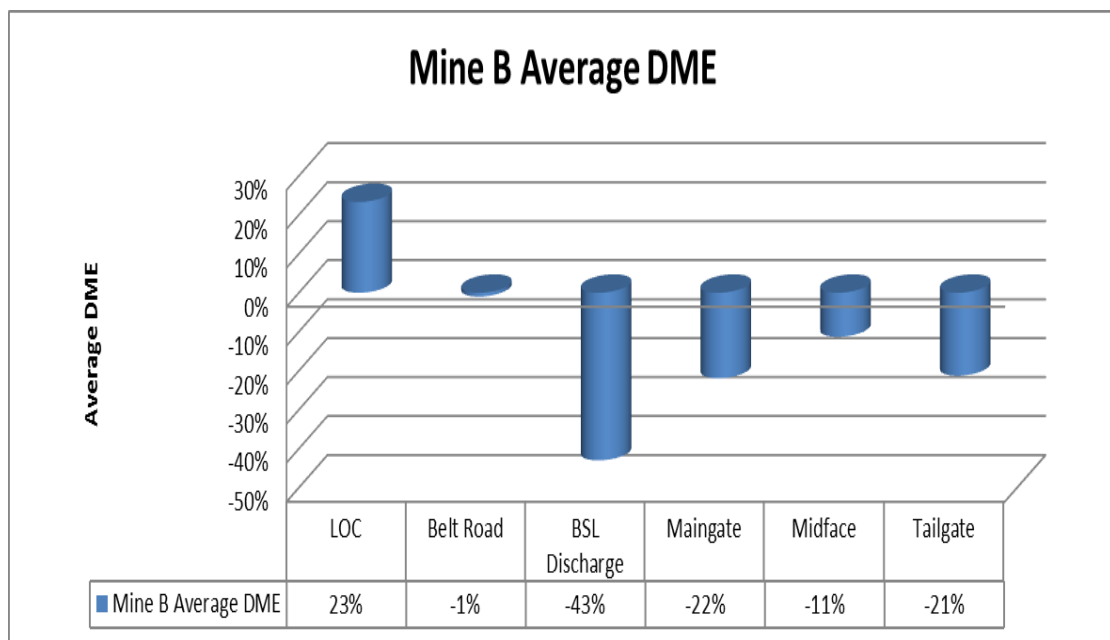
Figure 8.111 details the amount of inhalable dust produced by Mine A during the cutting cycle at each location tested with installed engineering controls operating. This is compared to the average inhalable dust produced at the same locations for all mines tested. Figure 8.112 shows that Mine A produced 28% more inhalable dust at the LOC, 27% more at the belt road, 295% more at the BSL discharge, 211% more at the maingate, 142% more midface and 278% more than the average inhalable dust production at the tailgate.

Figure 8.113 shows that the average inhalable dust production with installed engineering controls operating of all mines tested is 4% from the LOC, 3% from the belt road, 8% from the BSL discharge, 8% from the maingate, 38% midface and 39% in the tailgate. Mine A's inhalable dust production with all installed engineering controls operating was 2% from the LOC, 1% from the belt road, 10% from the BSL discharge, 8% from the maingate, 30% midface and 49% in the tailgate.

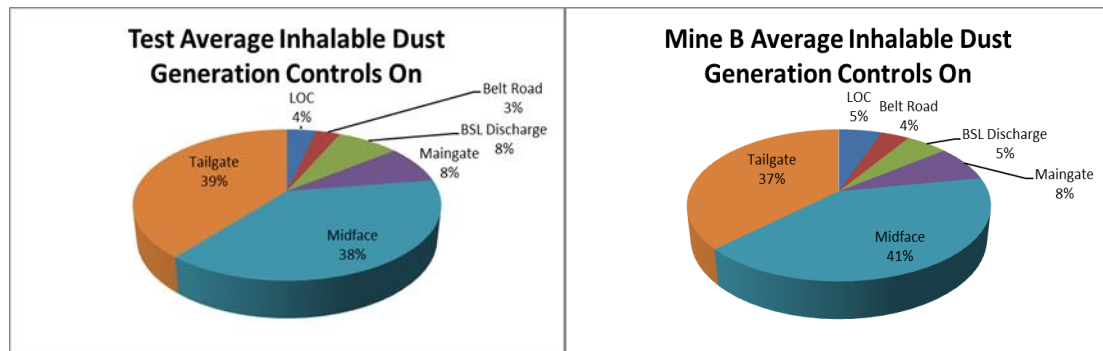
**8.24.3 Mine B Inhalable Dust Load Production Analysis**



**Figure 8.114 Mine B Inhalable Dust Production Comparison Controls On**



**Figure 8.115 Mine B Average Inhalable DME**



**Figure 8.116 Test Average and Mine B Average Inhalable Dust Production Controls On**

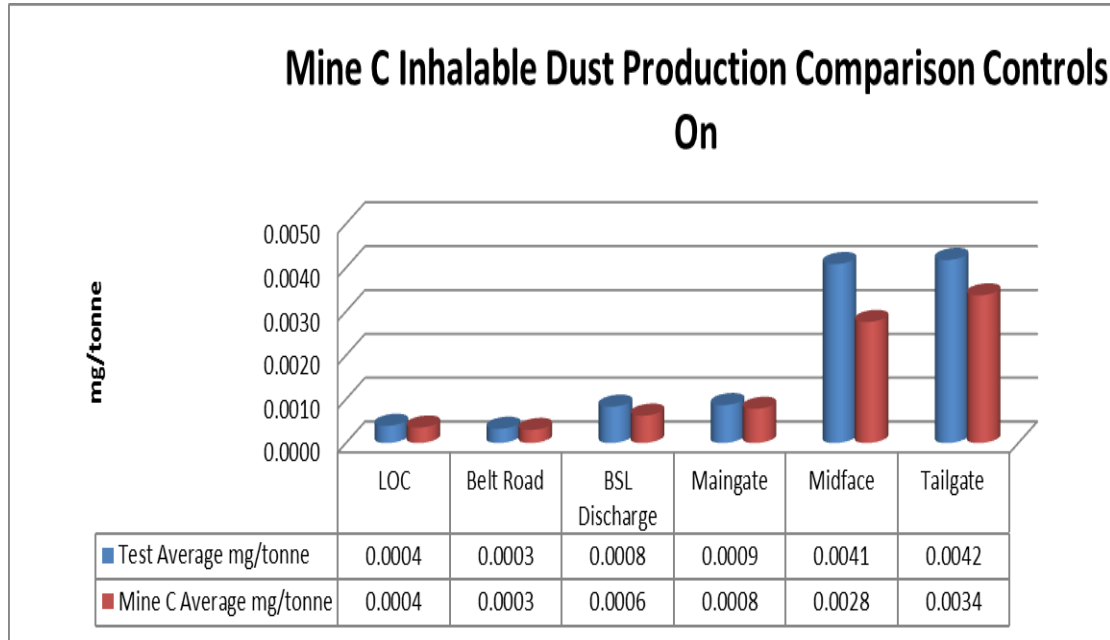
#### **8.24.4 Mine B Inhalable Dust Production Discussion**

Figure 8.114 details the amount of inhalable dust produced by Mine B during the cutting cycle at each location tested with installed engineering controls operating. This is compared to the average inhalable dust produced at the same locations for all mines tested. Figure 8.115 shows that Mine B produced 23% more inhalable dust at the LOC, 1% less at the belt road, 43% less at the BSL discharge, 22% less at the maingate, 11% less midface and 21% less than the average inhalable dust production at the tailgate.

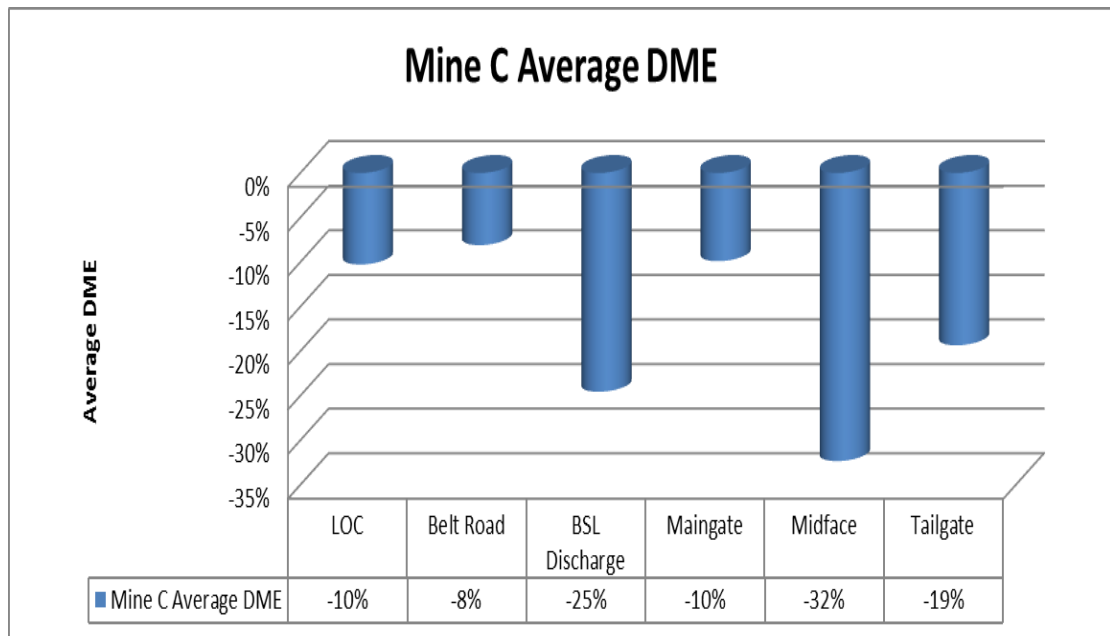
Figure 8.116 shows that the average inhalable dust production with installed engineering controls operating of all mines tested is 4% from the LOC, 3% from the belt road, 8% from the BSL discharge, 8% from the maingate, 38% midface and 39% in the tailgate. Mine B's inhalable dust production with all installed engineering controls operating was 5% from the LOC, 4% from the belt road, 5% from the BSL discharge, 8% from the maingate, 41% midface and 37% in the tailgate.



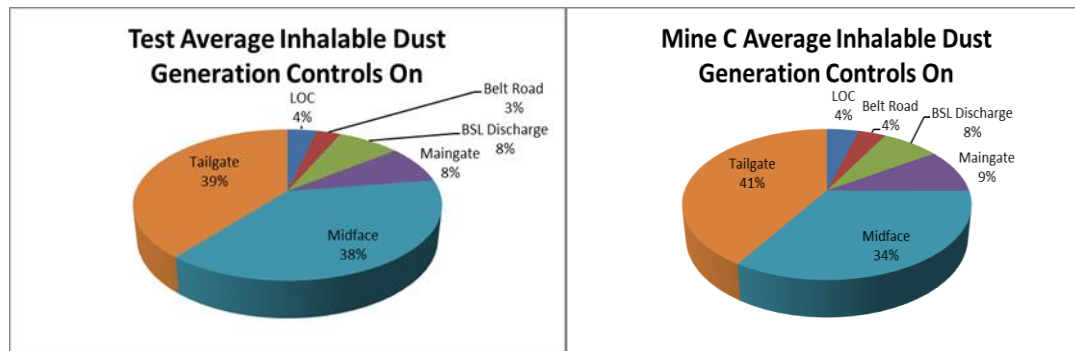
**8.24.5 Mine C Inhalable Dust Load Production Analysis**



**Figure 8.117 Mine C Inhalable Dust Production Comparison Controls On**



**Figure 8.118 Mine C Average Inhalable DME**



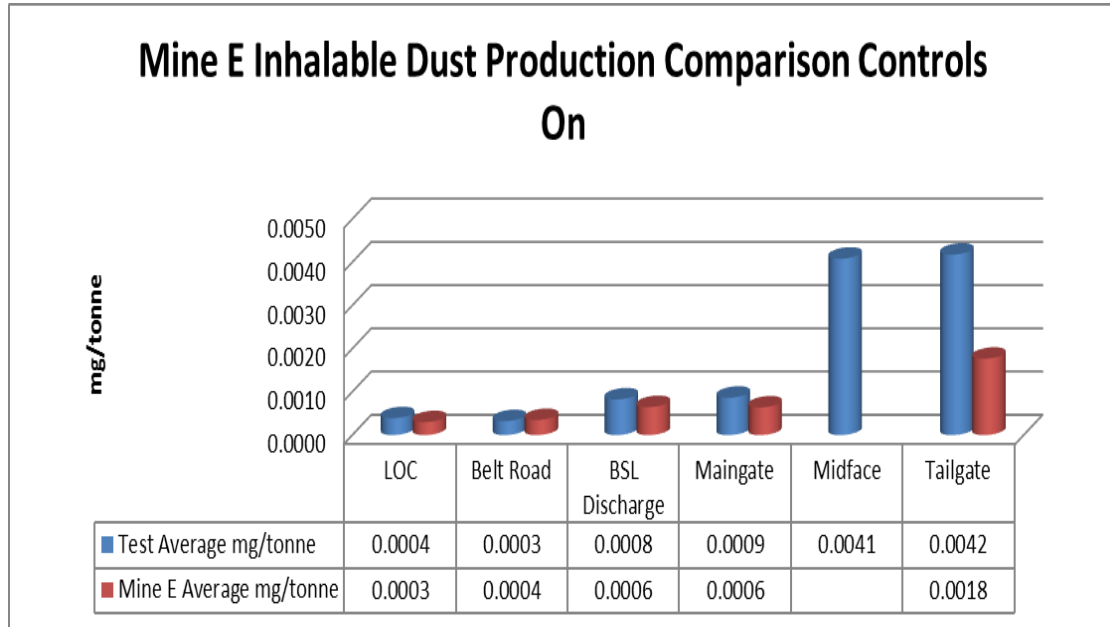
**Figure 8.119 Test Average and Mine C Average Inhalable Dust Production Controls On**

### 8.24.6 Mine C Inhalable Dust Production Discussion

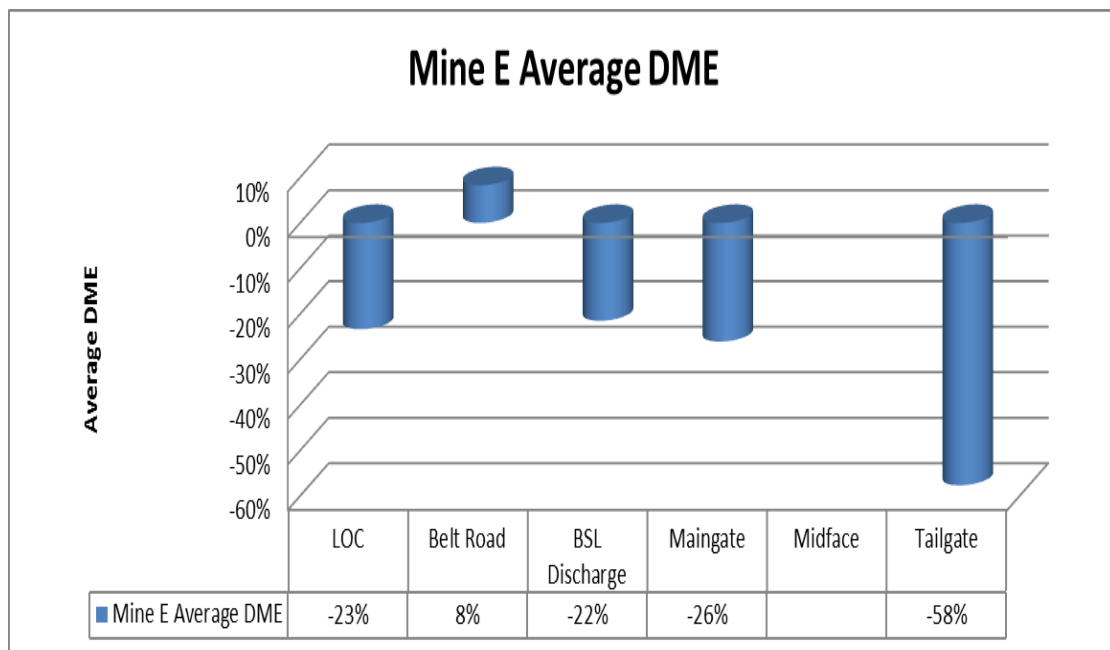
Figure 8.117 details the amount of inhalable dust produced by Mine C during the cutting cycle at each location tested with installed engineering controls operating. This is compared to the average inhalable dust produced at the same locations for all mines tested. Figure 8.118 shows that Mine C produced 10% less inhalable dust at the LOC, 8% less at the belt road, 25% less at the BSL discharge, 10% less at the maingate, 32% less midface and 19% less than the average inhalable dust production at the tailgate.

Figure 8.119 shows that the average inhalable dust production with installed engineering controls operating of all mines tested is 4% from the LOC, 3% from the belt road, 8% from the BSL discharge, 8% from the maingate, 38% midface and 39% in the tailgate. Mine C's inhalable dust production with all installed engineering controls operating was 4% from the LOC, 4% from the belt road, 8% from the BSL discharge, 9% from the maingate, 34% midface and 41% in the tailgate.

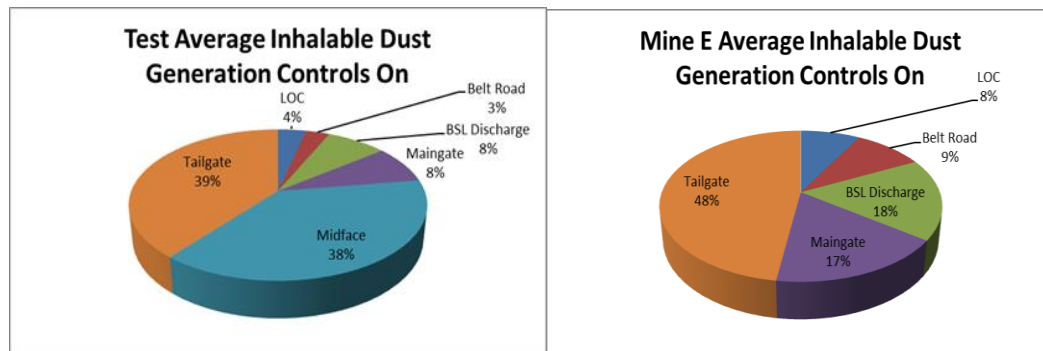
**8.24.7 Mine E Inhalable Dust Load Production Analysis**



**Figure 8.120 Mine E Inhalable Dust Production Comparison Controls On**



**Figure 8.121 Mine E Average Inhalable DME**



**Figure 8.122 Test Average and Mine E Average Inhalable Dust Production Controls On**

### 8.24.8 Mine E Inhalable Dust Production Discussion

Figure 8.120 details the amount of inhalable dust produced by Mine E during the cutting cycle at each location tested with installed engineering controls operating. This is compared to the average inhalable dust produced at the same locations for all mines tested. Figure 8.121 shows that Mine E produced 23% less inhalable dust at the LOC, 8% more at the belt road, 22% less at the BSL discharge, 26% less at the maingate, and 58% less than the average inhalable dust production at the tailgate.

Figure 8.122 shows that the average inhalable dust production with installed engineering controls operating of all mines tested is 4% from the LOC, 3% from the belt road, 8% from the BSL discharge, 8% from the maingate, 38% midface and 39% in the tailgate. Mine E's inhalable dust production with all installed engineering controls operating was 8% from the LOC, 8% from the belt road, 18% from the BSL discharge, 17% from the maingate, and 48% in the tailgate.

## **CHAPTER NINE - BEST PRACTICE FOR LONGWALL DUST MITIGATION**

### **9.1 Introduction**

The application of the DME model to measure respirable and inhalable dust load production at independent sources of dust generation on an operating longwall has also been successful in quantifying the installed engineering controls that are the most efficient at mitigating this produced dust at each of these independent sources of dust generation.

By applying the most efficient control quantified at each of these sources of dust generation, an operating longwall can maximise dust mitigation which will not only ensure statutory compliance to dust regulations, but will provide the healthiest and safest working environment for workers on the longwall.

This chapter will identify the most efficient engineering controls at the LOC, belt road, BSL discharge, maingate and on the face, thus providing quantified parameters for operators to integrate into their existing longwall operations which will maximise the amount of respirable and inhalable dust mitigated during the cutting cycle.

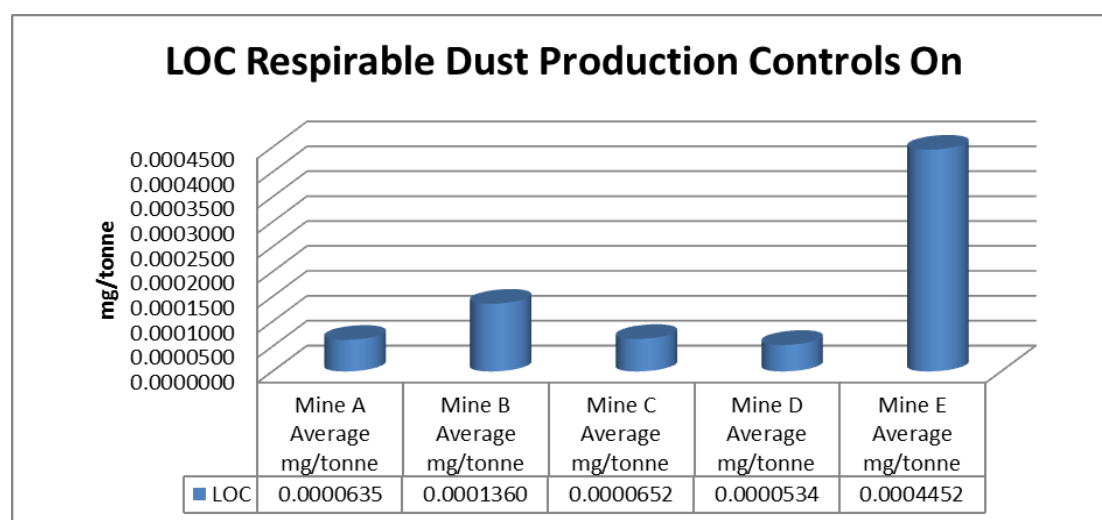
### **9.2 Parametric Configuration for LOC**

The LOC is contaminated by travel road and outbye dust brought into the longwall on the intake ventilation. This section identifies the mine that produces the least amount of respirable and inhalable dust coming in to the longwall on the intake ventilation and details the installed engineering controls that have been the most efficient at removing this produced dust.

### 9.2.1 LOC Respirable Dust Production Controls On

**Table 9.1 LOC Average Respirable Dust Production Controls On**

	LOC	Ventilation
Test 1-Mine A	0.0000635	
Mine A Average mg/tonne	<b>0.0000635</b>	<b>45m<sup>3</sup>/sec</b>
Test 2-Mine B	0.0000773	
Test 6-Mine B	0.0002154	
Test 7-Mine B		
Test 10-Mine B		
Test 11-Mine B	0.0001154	
Mine B Average mg/tonne	<b>0.0001360</b>	<b>35m<sup>3</sup>/sec</b>
Test 3-Mine C	0.0000364	
Test 4-Mine C	0.0000537	
Test 5-Mine C	0.0001462	
Test 13-Mine C	0.0000417	
Test 14-Mine C	0.0000483	
Mine C Average mg/tonne	<b>0.0000652</b>	<b>38m<sup>3</sup>/sec</b>
Test 8-Mine D	0.0000867	
Test 9-Mine D	0.0000667	
Mine D Average mg/tonne	<b>0.0000534</b>	<b>65m<sup>3</sup>/sec</b>
Test 12-Mine E	0.0005640	
Test 15-Mine E	0.0003264	
Mine E Average mg/tonne	<b>0.0004452</b>	<b>35m<sup>3</sup>/sec</b>



**Figure 9.1 LOC Respirable Dust Production Controls On**

## CHAPTER NINE

### Best Practice For Longwall Dust Mitigation

---

#### 9.2.2 LOC Respirable Dust Production Discussion

Table 9.1 and Figure 9.1 detail the average respirable dust measured at the LOC with installed engineering controls operating. Mine D produces the lowest mg/tonne during the cutting cycle. The amount of respirable dust measured indicates that the outbye roadways do not produce dust during vehicle movements and this is due to the road into the longwall panel being continually wet. The respirable measurement also indicates that outbye support work is minimal.

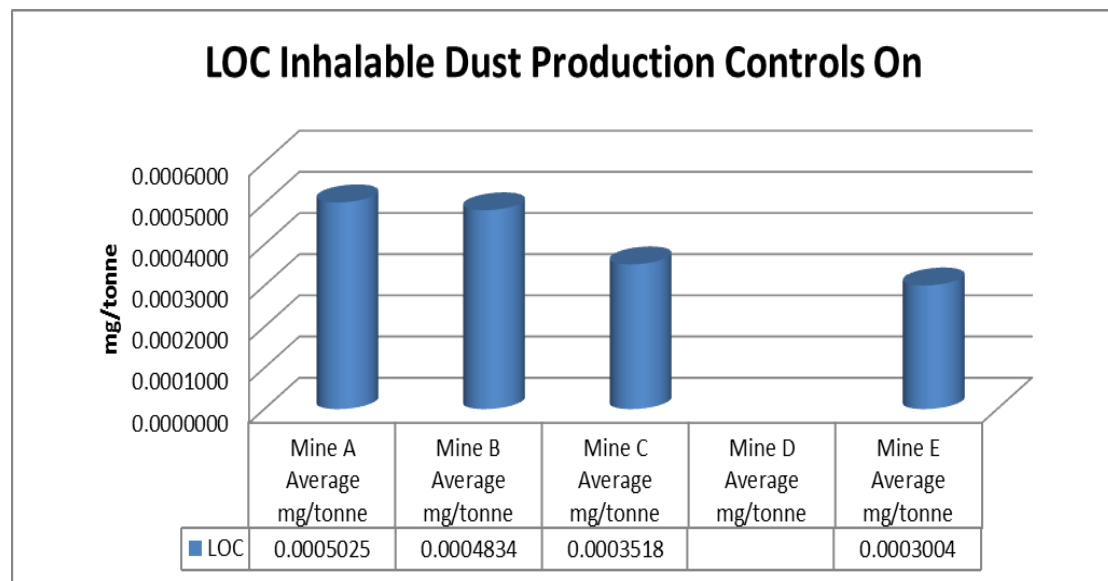
#### 9.2.3 LOC Inhalable Dust Production Controls On

**Table 9.2 LOC Inhalable Dust Production Controls On**

	LOC	Ventilation
Test 1-Mine A	0.0005025	
Mine A Average mg/tonne	<b>0.0005025</b>	<b>45m<sup>3</sup>/sec</b>
Test 2-Mine B	0.0002040	
Test 6-Mine B	0.0010000	
Test 7-Mine B		
Test 10-Mine B		
Test 11-Mine B	0.0002462	
Mine B Average mg/tonne	<b>0.0004834</b>	<b>35m<sup>3</sup>/sec</b>
Test 3-Mine C	0.0004013	
Test 4-Mine C	0.0003584	
Test 5-Mine C	0.0007692	
Test 13-Mine C	0.0000833	
Test 14-Mine C	0.0001467	
Mine C Average mg/tonne	<b>0.0003518</b>	<b>38m<sup>3</sup>/sec</b>
Test 8-Mine D		
Test 9-Mine D		
Mine D Average mg/tonne		<b>65m<sup>3</sup>/sec</b>
Test 12-Mine E	0.0004655	
Test 15-Mine E	0.0001354	
Mine E Average mg/tonne	<b>0.0003004</b>	<b>35m<sup>3</sup>/sec</b>

## CHAPTER NINE

### Best Practice For Longwall Dust Mitigation



**Figure 9.2 LOC Inhalable Dust Production Controls On**

#### 9.2.4 LOC Inhalable Dust Production Discussion

Table 9.2 and Figure 9.2 detail the average inhalable dust measured at the LOC with installed engineering controls operating. Mine E produces the lowest mg/tonne during the cutting cycle. The amount of inhalable dust measured indicates that the outbye roadways do not produce dust during vehicle movements and this is due to the road into the longwall panel being continually wet. The inhalable measurement also indicates that outbye support work is minimal.

#### 9.3 Parametric Configuration of the Belt Road

The belt road is contaminated by outbye dust generated by coal transported on the outbye belt brought into the longwall on the intake ventilation. This section identifies the mine that produces the least amount of respirable and inhalable dust coming in to the longwall on the intake ventilation and details the installed engineering controls that have been the most efficient at removing this produced dust.



## CHAPTER NINE

### Best Practice For Longwall Dust Mitigation

---

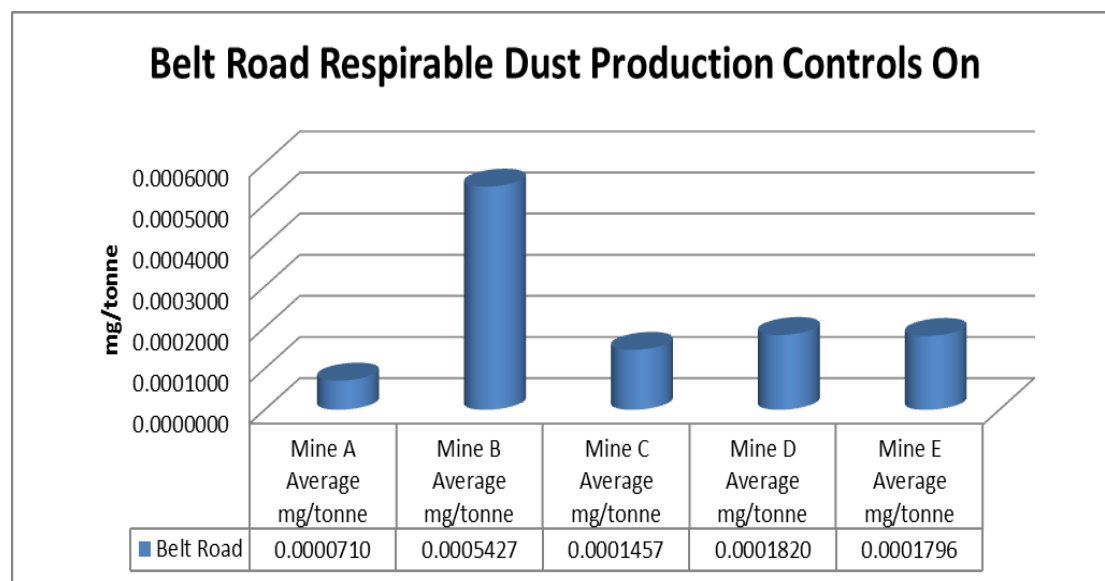
#### 9.3.1 Belt Road Respirable Dust Production Controls On

Table 9.3 Belt Road Average Respirable Dust Production Controls On

	Belt Road	Ventilation
Test 1-Mine A	0.0000710	
Mine A Average mg/tonne	<b>0.0000710</b>	<b>45m<sup>3</sup>/sec</b>
Test 2-Mine B	0.0013973	
Test 6-Mine B	0.0001538	
Test 7-Mine B		
Test 10-Mine B		
Test 11-Mine B	0.0000769	
Mine B Average mg/tonne	<b>0.0005427</b>	<b>35m<sup>3</sup>/sec</b>
Test 3-Mine C	0.0000545	
Test 4-Mine C	0.0004615	
Test 5-Mine C	0.0001333	
Test 13-Mine C	0.0000417	
Test 14-Mine C	0.0000375	
Mine C Average mg/tonne	<b>0.0001457</b>	<b>38m<sup>3</sup>/sec</b>
Test 8-Mine D	0.0003533	
Test 9-Mine D	0.0003733	
Mine D Average mg/tonne	<b>0.0001820</b>	<b>65m<sup>3</sup>/sec</b>
Test 12-Mine E	0.0001522	
Test 15-Mine E	0.0002070	
Mine E Average mg/tonne	<b>0.0001796</b>	<b>35m<sup>3</sup>/sec</b>

## CHAPTER NINE

### Best Practice For Longwall Dust Mitigation



**Figure 9.3 Belt Road Respirable Dust Production Controls On**

### 9.3.2 Belt Road Respirable Dust Production Discussion

Table 9.3 and Figure 9.3 detail the average respirable dust measured at the belt road with installed engineering controls operating. Mine A produces the lowest mg/tonne during the cutting cycle. The amount of respirable dust measured indicates that the belt road produces the least amount of dust during coal transportation and this is due to the coal being continually wet.

### 9.3.3 Belt Road Inhalable Dust Production Controls On

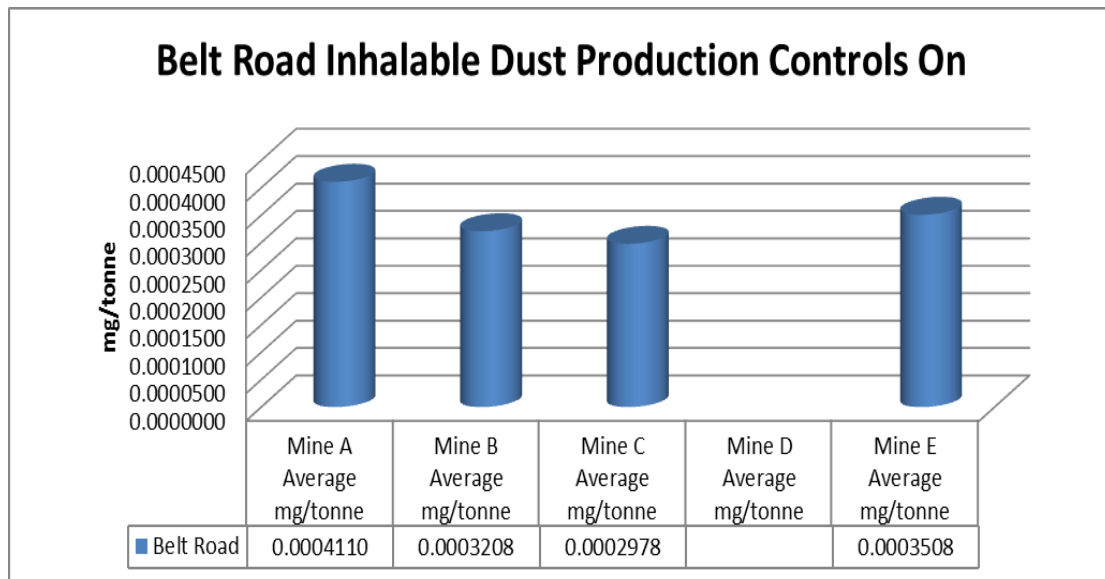
**Table 9.4 Belt Road Inhalable Dust Production Controls On**

	LOC	Ventilation
Test 1-Mine A	0.0004110	
<b>Mine A Average mg/tonne</b>	<b>0.0004110</b>	<b>45m<sup>3</sup>/sec</b>
Test 2-Mine B	0.0002240	
Test 6-Mine B	0.0004154	
Test 7-Mine B		
Test 10-Mine B		
Test 11-Mine B	0.0003231	
<b>Mine B Average mg/tonne</b>	<b>0.0003208</b>	<b>35m<sup>3</sup>/sec</b>
Test 3-Mine C	0.0002131	
Test 4-Mine C	0.0004666	
Test 5-Mine C	0.0006308	
Test 13-Mine C	0.0000917	

## CHAPTER NINE

### Best Practice For Longwall Dust Mitigation

Test 14-Mine C	0.0000867	
Mine C Average mg/tonne	<b>0.0002978</b>	<b>38m<sup>3</sup>/sec</b>
Test 8-Mine D		
Test 9-Mine D		
Mine D Average mg/tonne		<b>65m<sup>3</sup>/sec</b>
Test 12-Mine E	0.0001522	
Test 15-Mine E	0.0005494	
Mine E Average mg/tonne	<b>0.0003508</b>	<b>35m<sup>3</sup>/sec</b>



**Figure 9.4 Belt Road Inhalable Dust Production Controls On**

### 9.3.4 Belt Road Inhalable Dust Production Discussion

Table 9.4 and Figure 9.4 detail the average inhalable dust measured at the belt road with installed engineering controls operating. Mine C produces the lowest mg/tonne during the cutting cycle. The amount of respirable dust measured indicates that the belt road produces the least amount of dust during coal transportation and this is due to the coal being continually wet.

## 9.4 Parametric Configuration of the BSL Discharge

Inbye of the BSL discharge measures the amount of respirable and inhalable dust produced by coal discharging on to the outbye belt and then brought into the longwall on the intake ventilation. This section identifies the mine that produces the least amount of respirable and inhalable dust coming in to the maingate from the BSL

## CHAPTER NINE

### Best Practice For Longwall Dust Mitigation

discharge and details the installed engineering controls that have been the most efficient at removing this produced dust.

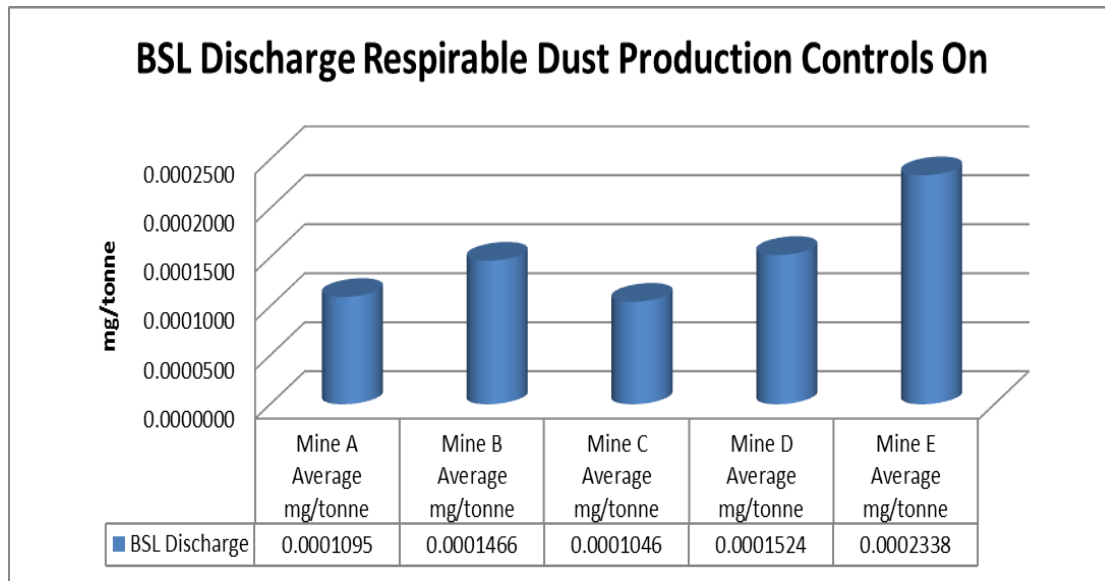
#### 9.4.1 BSL Discharge Respirable Dust Production Controls On

Table 9.5 BSL Discharge Average Respirable Dust Production Controls On

	<b>BSL Discharge</b>	<b>Ventilation</b>
<b>Test 1-Mine A</b>	0.0001095	
<b>Mine A Average mg/tonne</b>	<b>0.0001095</b>	<b>45m<sup>3</sup>/sec</b>
<b>Test 2-Mine B</b>	0.0001320	
<b>Test 6-Mine B</b>	0.0002154	
<b>Test 7-Mine B</b>		
<b>Test 10-Mine B</b>		
<b>Test 11-Mine B</b>	0.0000923	
<b>Mine B Average mg/tonne</b>	<b>0.0001466</b>	<b>35m<sup>3</sup>/sec</b>
<b>Test 3-Mine C</b>	0.0000455	
<b>Test 4-Mine C</b>	0.0000870	
<b>Test 5-Mine C</b>	0.0002000	
<b>Test 13-Mine C</b>	0.0001000	
<b>Test 14-Mine C</b>	0.0000908	
<b>Mine C Average mg/tonne</b>	<b>0.0001046</b>	<b>38m<sup>3</sup>/sec</b>
<b>Test 8-Mine D</b>	0.0002533	
<b>Test 9-Mine D</b>	0.0003133	
<b>Mine D Average mg/tonne</b>	<b>0.0001524</b>	<b>65m<sup>3</sup>/sec</b>
<b>Test 12-Mine E</b>	0.0004118	
<b>Test 15-Mine E</b>	0.0000557	
<b>Mine E Average mg/tonne</b>	<b>0.0002338</b>	<b>35m<sup>3</sup>/sec</b>

## CHAPTER NINE

### Best Practice For Longwall Dust Mitigation



**Figure 9.5 BSL Discharge Respirable Dust Production Controls On**

#### 9.4.2 BSL Discharge Respirable Dust Production Discussion

Table 9.5 and Figure 9.5 detail the average respirable dust measured inbye of the BSL discharge with installed engineering controls operating. Mine C produces the lowest mg/tonne during the cutting cycle. The amount of respirable dust measured indicates that the installed engineering controls operating at Mine C are the most efficient at mitigating produced respirable dust.

#### 9.4.3 BSL Discharge Installed Engineering Controls at Mine C for Respirable Dust

Mine C has been identified as producing the least amount of respirable dust from the BSL discharge. All mines have installed engineering controls at the BSL discharge and testing has quantified that those controls installed at Mine C are the most efficient at mitigating respirable dust. Table 9.6 details the installed engineering controls at Mine C on the BSL discharge.

## CHAPTER NINE

### Best Practice For Longwall Dust Mitigation

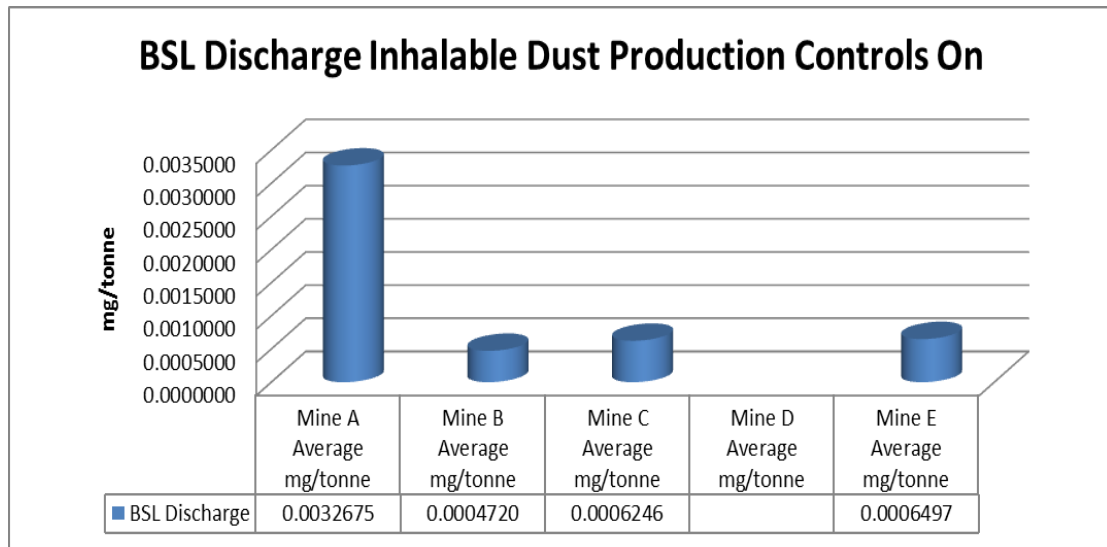
**Table 9.6 BSL Discharge Installed Engineering Controls at Mine C for Respirable Dust**

<b>BSL discharge</b>	
Number of sprays in BSL discharge	3
Type	V-Spray
Spray Diameter	4mm
Water Pressure	1200kPa
Water Flow	45lpm
Scrubber installed drawing from discharge	

#### 9.4.4 BSL Discharge Inhalable Dust Production Controls On

**Table 9.7 BSL Discharge Inhalable Dust Production Controls On**

	BSL Discharge	Ventilation
Test 1-Mine A	0.0032675	
<b>Mine A Average mg/tonne</b>	<b>0.0032675</b>	<b>45m<sup>3</sup>/sec</b>
Test 2-Mine B	0.0003467	
Test 6-Mine B	0.0007077	
Test 7-Mine B		
Test 10-Mine B		
Test 11-Mine B	0.0003615	
<b>Mine B Average mg/tonne</b>	<b>0.0004720</b>	<b>35m<sup>3</sup>/sec</b>
Test 3-Mine C	0.0003515	
Test 4-Mine C	0.0005239	
Test 5-Mine C	0.0014333	
Test 13-Mine C	0.0004500	
Test 14-Mine C	0.0003642	
<b>Mine C Average mg/tonne</b>	<b>0.0006246</b>	<b>38m<sup>3</sup>/sec</b>
Test 8-Mine D		
Test 9-Mine D		
<b>Mine D Average mg/tonne</b>		<b>65m<sup>3</sup>/sec</b>
Test 12-Mine E	0.0005909	
Test 15-Mine E	0.0007086	
<b>Mine E Average mg/tonne</b>	<b>0.0006497</b>	<b>35m<sup>3</sup>/sec</b>



**Figure 9.6 BSL Discharge Inhalable Dust Production Controls On**

**9.4.5 BSL Discharge Inhalable Dust Production Discussion**

Table 9.7 and Figure 9.6 detail the average inhalable dust measured inbye of the BSL discharge with installed engineering controls operating. Mine B produces the lowest mg/tonne during the cutting cycle. The amount of respirable dust measured indicates that the installed engineering controls operating at Mine B are the most efficient at mitigating produced respirable dust.

**9.4.6 BSL Discharge Installed Engineering Controls at Mine B for Inhalable Dust**

Mine B has been identified as producing the least amount of inhalable dust from the BSL discharge. All mines have installed engineering controls at the BSL discharge and testing has quantified that those controls installed at Mine B are the most efficient at mitigating inhalable dust. Figure 9.8 details the installed engineering controls at Mine B on the BSL discharge.

## CHAPTER NINE

### Best Practice For Longwall Dust Mitigation

**Table 9.8 BSL Discharge Installed Engineering Controls at Mine B for Inhalable Dust**

<b>BSL discharge</b>	
Number of sprays in BSL discharge	3
Type	Hollow Cone
Spray Diameter	6mm
Water Pressure	15Bar
Water Flow	NA
Scrubber installed drawing from the discharge	

## 9.5 Parametric Configuration of the Maingate

Maingate measures the amount of respirable and inhalable dust produced by the cut coal being taken into the crusher for sizing on to the outbye belt and then brought into the longwall on the intake ventilation. This section identifies the mine that produces the least amount of respirable and inhalable dust coming from the crusher and details the installed engineering controls that have been the most efficient at removing this produced dust.

### 9.5.1 The Maingate Respirable Dust Production Controls On

**Table 9.9 The Maingate Average Respirable Dust Production Controls On**

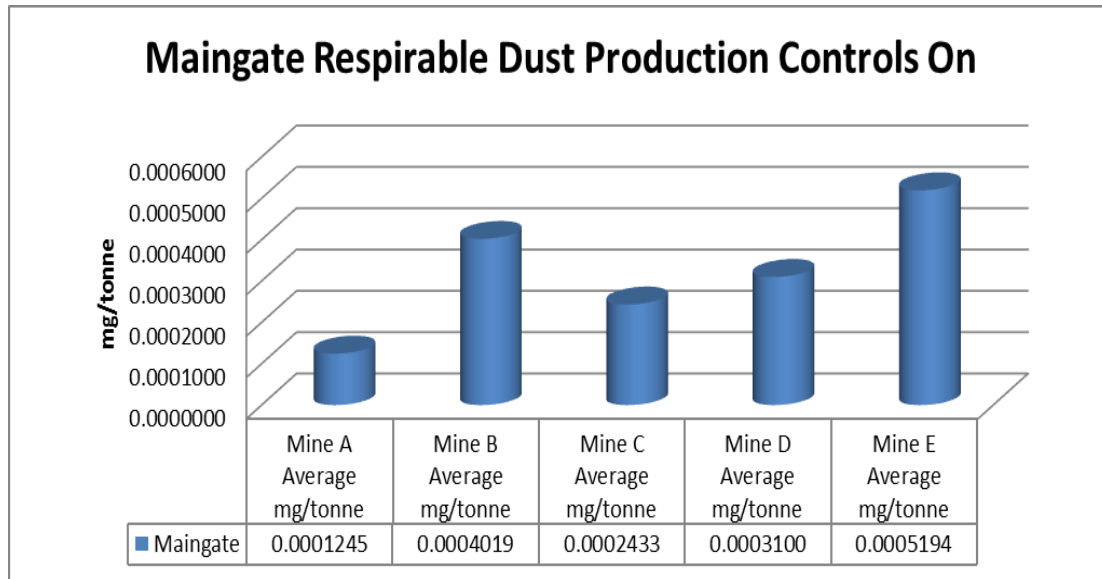
	Maingate	Ventilation
<b>Test 1-Mine A</b>	0.0001245	
<b>Mine A Average mg/tonne</b>	<b>0.0001245</b>	<b>45m<sup>3</sup>/sec</b>
<b>Test 2-Mine B</b>	0.0001480	
<b>Test 6-Mine B</b>	0.0002154	
<b>Test 7-Mine B</b>	0.0006769	
<b>Test 10-Mine B</b>	0.0006615	
<b>Test 11-Mine B</b>	0.0003077	
<b>Mine B Average mg/tonne</b>	<b>0.0004019</b>	<b>35m<sup>3</sup>/sec</b>
<b>Test 3-Mine C</b>	0.0001091	
<b>Test 4-Mine C</b>	0.0001156	
<b>Test 5-Mine C</b>	0.0006667	
<b>Test 13-Mine C</b>	0.0001583	
<b>Test 14-Mine C</b>	0.0001667	
<b>Mine C Average mg/tonne</b>	<b>0.0002433</b>	<b>38m<sup>3</sup>/sec</b>



**CHAPTER NINE**

**Best Practice For Longwall Dust Mitigation**

<b>Test 8-Mine D</b>	0.0005133	
<b>Test 9-Mine D</b>	0.0006267	
<b>Mine D Average mg/tonne</b>	<b>0.0003100</b>	<b>65m<sup>3</sup>/sec</b>
<b>Test 12-Mine E</b>	0.0002507	
<b>Test 15-Mine E</b>	0.0007882	
<b>Mine E Average mg/tonne</b>	<b>0.0005194</b>	<b>35m<sup>3</sup>/sec</b>



**Figure 9.7 The Maingate Respirable Dust Production Controls On**

**9.5.2 The Maingate Respirable Dust Production Discussion**

Table 9.9 and Figure 9.7 detail the average respirable dust measured at the maingate with installed engineering controls operating. Mine A produces the lowest mg/tonne during the cutting cycle. The amount of respirable dust measured indicates that the installed engineering controls operating at Mine A are the most efficient at mitigating produced respirable dust.

**9.5.3 The Maingate Installed Engineering Controls at Mine A for Respirable Dust**

Mine A has been identified as producing the least amount of respirable dust from the maingate. All mines have installed engineering controls at the maingate and testing has quantified that those controls installed at Mine A are the most efficient at

## CHAPTER NINE

### Best Practice For Longwall Dust Mitigation

mitigating respirable dust. Table 9.10 details the installed engineering controls at Mine A at the maingate.

**Table 9.10 The Maingate Installed Engineering Controls at Mine A for Respirable Dust**

<b>BSL Sprays</b>	
Number of sprays	12
Type	Hollow Cone
Spray Diameter	6mm
Water Pressure	20Bar
Water Flow	135lpm
<b>BSL crusher</b>	
Number of sprays	12
Type	Hollow Cone
Spray Diameter	6mm
Water Pressure	20Bar
Water Flow	135lpm
Scrubber installed drawing from crusher	

#### 9.5.4 The Maingate Inhalable Dust Production Controls On

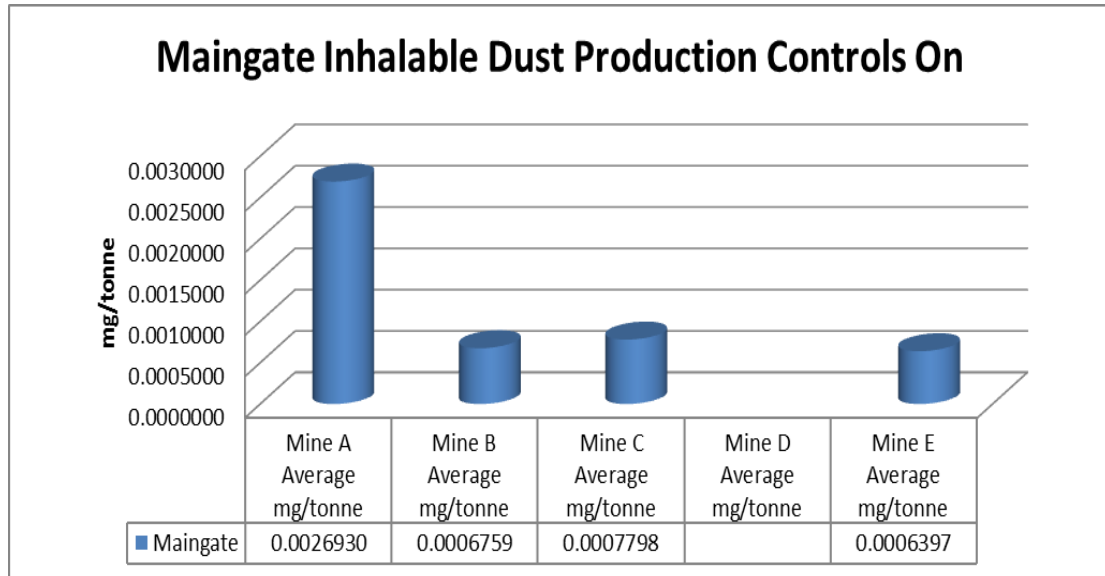
**Table 9.11 The Maingate Inhalable Dust Production Controls On**

	Maingate	Ventilation
Test 1-Mine A	0.0026930	
Mine A Average mg/tonne	<b>0.0026930</b>	<b>45m<sup>3</sup>/sec</b>
Test 2-Mine B	0.0003333	
Test 6-Mine B	0.0002615	
Test 7-Mine B	0.0010923	
Test 10-Mine B	0.0009692	
Test 11-Mine B	0.0007231	
Mine B Average mg/tonne	<b>0.0006759</b>	<b>35m<sup>3</sup>/sec</b>
Test 3-Mine C	0.0005624	
Test 4-Mine C	0.0009985	
Test 5-Mine C	0.0014308	
Test 13-Mine C	0.0005083	
Test 14-Mine C	0.0003992	
Mine C Average mg/tonne	<b>0.0007798</b>	<b>38m<sup>3</sup>/sec</b>
Test 8-Mine D		
Test 9-Mine D		
Mine D Average mg/tonne		<b>65m<sup>3</sup>/sec</b>

## CHAPTER NINE

### Best Practice For Longwall Dust Mitigation

<b>Test 12-Mine E</b>	0.0007699	
<b>Test 15-Mine E</b>	0.0005096	
<b>Mine E Average mg/tonne</b>	<b>0.0006397</b>	<b>35m<sup>3</sup>/sec</b>



**Figure 9.8 The Maingate Inhalable Dust Production Controls On**

#### 9.5.5 The Maingate Inhalable Dust Production Discussion

Table 9.11 and Figure 9.8 detail the average inhalable dust measured at the maingate with installed engineering controls operating. Mine E produces the lowest mg/tonne during the cutting cycle. The amount of Inhalable dust measured indicates that the installed engineering controls operating at Mine E are the most efficient at mitigating produced inhalable dust.

#### 9.5.6 The Maingate Installed Engineering Controls at Mine E for Inhalable Dust

Mine E has been identified as producing the least amount of inhalable dust from the maingate. All mines have installed engineering controls at the maingate and testing has quantified that those controls installed at Mine E are the most efficient at mitigating inhalable dust. Table 9.12 details the installed engineering controls at Mine E in the maingate.

## CHAPTER NINE

### Best Practice For Longwall Dust Mitigation

**Table 9.12 The Maingate Installed Engineering Controls at Mine E for Inhalable Dust**

<b>BSL Sprays</b>	
Number of sprays	3
Type	Hollow Cone
Spray Diameter	2mm
Water Pressure	20Bar
Water Flow	15lpm
<b>BSL crusher</b>	
Number of sprays	9
Type: Solid, Hollow cone, Flat, V	Hollow Cone
Spray Diameter	6mm
Water Pressure	20Bar
Sprays on Crusher Intake	3 x hollow cone, 2mm, 20 Bar over chain

## 9.6 Parametric Configuration of the Tailgate

The tailgate measures the amount of respirable and inhalable dust produced during the coal cutting cycle. This section identifies the mine that produces the least amount of respirable and inhalable dust during the cutting cycle and details the installed engineering controls that have been the most efficient at removing this produced dust.

### 9.6.1 The Tailgate Respirable Dust Production Controls On

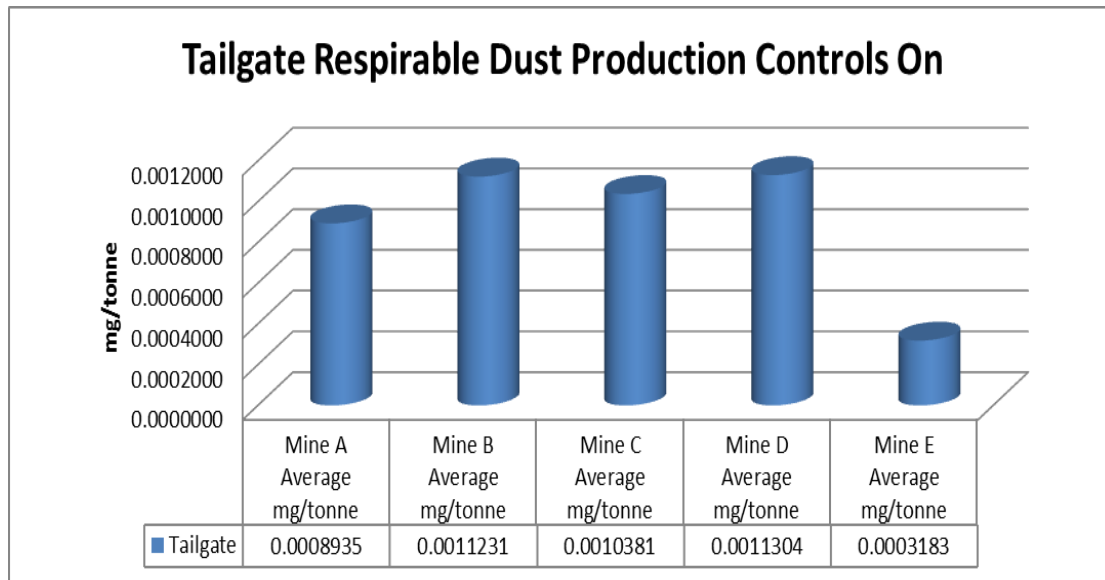
**Table 9.13 The Tailgate Average Respirable Dust Production Controls On**

	Tailgate	Ventilation
<b>Test 1-Mine A</b>	0.0008935	
<b>Mine A Average mg/tonne</b>	<b>0.0008935</b>	<b>45m<sup>3</sup>/sec</b>
<b>Test 2-Mine B</b>	0.0000000	
<b>Test 6-Mine B</b>		
<b>Test 7-Mine B</b>	0.0017231	
<b>Test 10-Mine B</b>	0.0014308	
<b>Test 11-Mine B</b>	0.0013385	
<b>Mine B Average mg/tonne</b>	<b>0.0011231</b>	<b>35m<sup>3</sup>/sec</b>
<b>Test 3-Mine C</b>	0.0011727	
<b>Test 4-Mine C</b>	0.0008694	
<b>Test 5-Mine C</b>	0.0014974	
<b>Test 13-Mine C</b>	0.0007500	

## CHAPTER NINE

### Best Practice For Longwall Dust Mitigation

<b>Test 14-Mine C</b>	0.0009008	
<b>Mine C Average mg/tonne</b>	<b>0.0010381</b>	<b>38m<sup>3</sup>/sec</b>
<b>Test 8-Mine D</b>	0.0017933	
<b>Test 9-Mine D</b>	0.0019200	
<b>Mine D Average mg/tonne</b>	<b>0.0011304</b>	<b>65m<sup>3</sup>/sec</b>
<b>Test 12-Mine E</b>	0.0005730	
<b>Test 15-Mine E</b>	0.0000637	
<b>Mine E Average mg/tonne</b>	<b>0.0003183</b>	<b>35m<sup>3</sup>/sec</b>



**Figure 9.9 The Tailgate Respirable Dust Production Controls On**

### 9.6.2 The Tailgate Respirable Dust Production Discussion

Table 9.13 and Figure 9.9 detail the average respirable dust measured at the tailgate with installed engineering controls operating. Mine E produces the lowest mg/tonne during the cutting cycle. The amount of respirable dust measured indicates that the installed engineering controls operating at Mine E are the most efficient at mitigating produced respirable dust.

### 9.6.3 The Tailgate Installed Engineering Controls at Mine E

Mine E has been identified as producing the least amount of respirable dust from the maingate. All mines have installed engineering controls at the maingate and testing

## CHAPTER NINE

### Best Practice For Longwall Dust Mitigation

has quantified that those controls installed at Mine E are the most efficient at mitigating respirable dust. The engineering controls that affect the dust measured at the tailgate are those installed on the shear and along the face. Figure 9.14 details the installed engineering controls at Mine E on the operating longwall.

**Table 9.14 The Tailgate Installed Engineering Controls at Mine E**

<b>Shearer</b>	
Number of sprays	64
Type	Solid Cone
Spray Diameter	1.2mm
Water Pressure	65Bar
Water Flow	475lpm
Types of Picks	Radial
<b>Chock Sprays</b>	
Number of sprays	4 per chock, 2 x front, 2 x rear
Type	Hollow Cone
Spray Diameter	1.2mm
Water Pressure	60Bar
Water Flow	100lpm
<b>Other Dust Controls Used</b>	
Shearer drum speed	30rpm
Shearer Speed	5-8m/minute

#### 9.6.4 The Tailgate Inhalable Dust Production Controls On

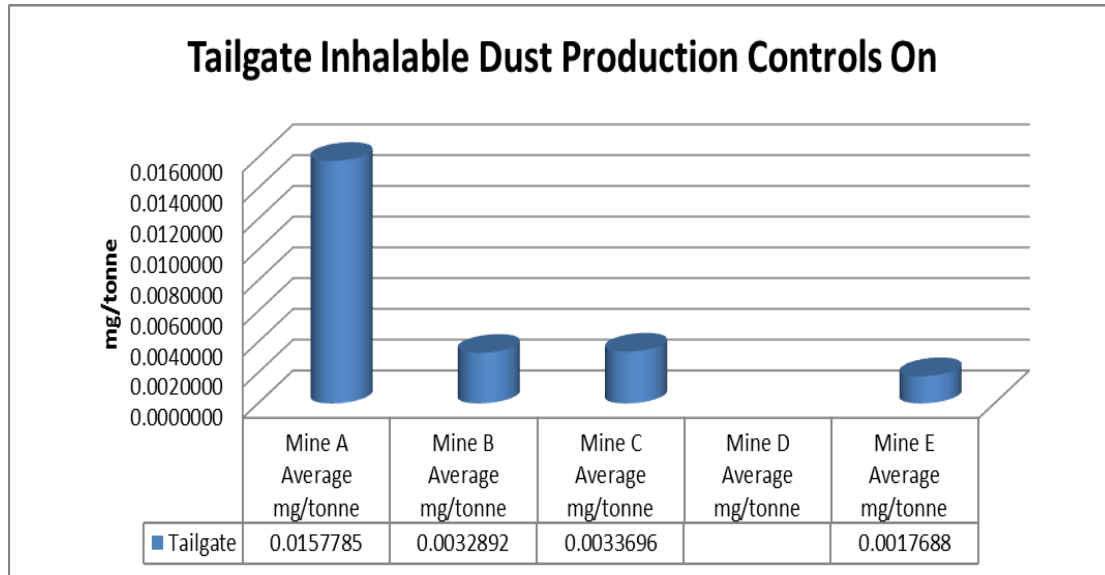
**Table 9.15 The Tailgate Inhalable Dust Production Controls On**

	Tailgate	Ventilation
Test 1-Mine A	0.0157785	
<b>Mine A Average mg/tonne</b>	<b>0.0157785</b>	<b>45m<sup>3</sup>/sec</b>
Test 2-Mine B	0.0055720	
Test 6-Mine B		
Test 7-Mine B	0.0040769	
Test 10-Mine B	0.0021077	
Test 11-Mine B	0.0014000	
<b>Mine B Average mg/tonne</b>	<b>0.0032892</b>	<b>35m<sup>3</sup>/sec</b>
Test 3-Mine C	0.0032163	
Test 4-Mine C	0.0048881	
Test 5-Mine C	0.0025282	
Test 13-Mine C		
Test 14-Mine C	0.0028458	
<b>Mine C Average mg/tonne</b>	<b>0.0033696</b>	<b>38m<sup>3</sup>/sec</b>
Test 8-Mine D		

## CHAPTER NINE

### Best Practice For Longwall Dust Mitigation

<b>Test 9-Mine D</b>		
<b>Mine D Average mg/tonne</b>		<b>65m<sup>3</sup>/sec</b>
<b>Test 12-Mine E</b>	0.0008863	
<b>Test 15-Mine E</b>	0.0026513	
<b>Mine E Average mg/tonne</b>	<b>0.0017688</b>	<b>35m<sup>3</sup>/sec</b>



**Figure 9.10 The Tailgate Inhalable Dust Production Controls On**

### 9.6.5 The Tailgate Inhalable Dust Production Discussion

Table 9.15 and Figure 9.10 detail the average inhalable dust measured at the maingate with installed engineering controls operating. Mine E produces the lowest mg/tonne during the cutting cycle. The amount of inhalable dust measured indicates that the installed engineering controls operating at Mine E are the most efficient at mitigating produced inhalable dust.

### 9.6.6 The Tailgate Installed Engineering Controls at Mine E for Inhalable Dust

Mine E has been identified as producing the least amount of inhalable dust from the tailgate. All mines have installed engineering controls at the maingate and testing has quantified that those controls installed at Mine E are the most efficient at mitigating inhalable dust. Figure 9.16 details the installed engineering controls at Mine E at the tailgate.

## CHAPTER NINE

### Best Practice For Longwall Dust Mitigation

---

**Table 9.16 The Tailgate Installed Engineering Controls at Mine E for Inhalable Dust**

<b>Shearer</b>	
Number of sprays	64
Type	Solid Cone
Spray Diameter	1.2mm
Water Pressure	65Bar
Water Flow	475lpm
Types of Picks	Radial
<b>Chock Sprays</b>	
Number of sprays	4 per chock, 2 x front, 2 x rear
Type	Hollow Cone
Spray Diameter	1.2mm
Water Pressure	60Bar
Water Flow	100lpm
<b>Other Dust Controls Used</b>	
Shearer drum speed	30rpm
Shearer Speed	5-8m/minute

## 9.7 Respirable Dust Best Practice Engineering Controls

This section details the installed engineering controls identified by the DME model as the most efficient at mitigating respirable dust at each of the identified sources of dust generation on an operating longwall. Table 9.17 details the best practice engineering controls for mitigating respirable dust from the BSL discharge to the tailgate.

**Table 9.17 Respirable Dust Best Practice Engineering Controls**

<b>BSL discharge</b>	
Number of sprays in BSL discharge	3
Type	V-Spray
Spray Diameter	4mm
Water Pressure	1200kPa
Water Flow	45lpm
Scrubber installed drawing from discharge	
<b>BSL Sprays</b>	
Number of sprays	12
Type	Hollow Cone
Spray Diameter	6mm
Water Pressure	20Bar
Water Flow	135lpm
<b>BSL crusher</b>	
Number of sprays	12



## CHAPTER NINE

### Best Practice For Longwall Dust Mitigation

Type	Hollow Cone
Spray Diameter	6mm
Water Pressure	20Bar
Water Flow	135lpm
Scrubber drawing from crusher	
<b>Shearer</b>	
Number of sprays	64
Type	Solid Cone
Spray Diameter	1.2mm
Water Pressure	65Bar
Water Flow	475lpm
Types of Picks	Radial
<b>Chock Sprays</b>	
Number of sprays	4 per chock 2 x front, 2 x rear
Type	Hollow Cone
Spray Diameter	1.2mm
Water Pressure	60Bar
Water Flow	100lpm
<b>Other Dust Controls Used</b>	
Shearer drum speed	30rpm
Shearer Speed	5-8m/minute

## 9.8 Inhalable Dust Best Practice Engineering Controls

This section details the installed engineering controls identified by the DME model as the most efficient at mitigating inhalable dust at each of the identified sources of dust generation on an operating longwall. Table 9.18 details the best practice engineering controls for mitigating inhalable dust from the BSL discharge to the tailgate.

**Table 9.18 Inhalable Dust Best Practice Engineering Controls**

<b>BSL discharge</b>	
Number of sprays in BSL discharge	3
Type: Solid, Hollow cone, Flat, V	Hollow Cone
Spray Diameter	6mm
Water Pressure	15Bar
Water Flow	45lpm
Scrubber installed drawing from the discharge	
<b>BSL Sprays</b>	
Number of sprays	3
Type	Hollow Cone
Spray Diameter	2mm
Water Pressure	20Bar
Water Flow	15lpm
<b>BSL crusher</b>	

## CHAPTER NINE

### Best Practice For Longwall Dust Mitigation

Number of sprays	9
Type: Solid, Hollow cone, Flat, V	Hollow Cone
Spray Diameter	6mm
Water Pressure	20Bar
Sprays on Crusher Intake	3 x hollow cone, 2mm, 20 Bar over chain
<b>Shearer</b>	
Number of sprays	64
Type: Solid, Hollow cone, Flat, V	Solid Cone
Spray Diameter	1.2mm
Water Pressure	65Bar
Water Flow	475lpm
Types of Picks	Radial
<b>Chock Sprays</b>	
Number of sprays	4 per chock, 2 x front, 2 x rear
Type: Solid, Hollow cone, Flat, V	Hollow Cone
Spray Diameter	1.2mm
Water Pressure	60Bar
Water Flow	100lpm
<b>Other Dust Controls Used</b>	
Shearer drum speed	30rpm
Shearer Speed	5-8m/minute

## 9.9 Summary

The DME model has successfully identified the most efficient installed engineering controls operating at individual sources of respirable and inhalable dust generation on operating longwalls in Australia. The use of the DME model as opposed to the statutory measurement process will allow mine operators to establish a dust mitigation regime based on the measured installed control efficiencies.

By installing the best practice engineering controls, operators are in a better position to ensure compliance to regulatory standards for exposure levels and most importantly, they are ensuring minimum risk to worker health by ensuring they are mitigating the most respirable and inhalable dust possible from the mining environment.

Development and practical application of the DME model through comprehensive and robust testing, has seen the mentioned best practice engineering controls for the

## **CHAPTER NINE**

### **Best Practice For Longwall Dust Mitigation**

---

mitigation created based on quantifiable data analysis and results. Mine operators have the capacity to install these controls at known sources of dust generation confident that they will mitigate the maximum amount of respirable and inhalable dust generated during the cutting cycle.

Further efficiencies will be created as more products are quantified using the DME model, eventually resulting in a workplace environment that will pass statutory requirements and more importantly clean the atmosphere from harmful contaminants.

## CHAPTER TEN – CONCLUSIONS and RECOMMENDATIONS

### 10.1 Conclusion

A Dust Mitigation Efficiency (DME) model has been developed in this thesis to identify respirable and inhalable dust loads at independent sources of dust generation on longwall faces and quantify the efficiency of installed controls for the mitigation of this produced dust. The data collected from each of the sampled mines during the field trials has been used to create a benchmark or signature for each longwall of those mines in relation to dust loads from different sources of generation to ensure maximum efficiency in removing respirable and inhalable dusts.

The DME model is represented by the following formula:

$$DME_n = \left( \frac{\left( \frac{W_{ef} - W_{ei}}{T_e} \right) - \left( \frac{W_{bf} - W_{bi}}{T_b} \right)}{\left( \frac{W_{bf} - W_{bi}}{T_b} \right)} \right) \times 100$$

Where:

DME =	Dust Mitigation Efficiency
$n$ =	Location of monitors and heads
$W_{bi}$ =	Weight of initial benchmark test filter unladen, in milligrams
$W_{bf}$ =	Weight of final benchmark test filter used, in milligrams
$T_b$ =	Tonnes cut for benchmark testing
$W_{ei}$ =	Weight of initial efficiency test filter unladen, in milligrams
$W_{ef}$ =	Weight of final efficiency test filter used, in milligrams
$T_e$ =	Tonnes cut for efficiency testing

The DME is presented as a percentage (%) change in the mg/tonne produced at each individual source of dust generation sampled. This can be either a positive or negative number, with the negative number representing a reduction in dust or a positive number an increase in dust when installed engineering controls are operating.

## CHAPTER TEN

### Recommendation and Conclusion

---

The DME model has successfully identified the most efficient installed engineering controls operating at individual sources of respirable and inhalable dust generation on operating longwalls in Australia. The use of the DME model as opposed to the statutory measurement process will allow mine operators to establish a dust mitigation regime based on the measured best practice as detailed in Chapter 9.

The DME model has proven to be reliable, robust, flexible and sensitive. Reliability has been proven by the parallel samples taken by Coal Services in which both results were very similar, the robustness is shown by the continued gathering of reliable and useful data, the flexibility is demonstrated by its ability to adapt to a required or designed testing methodology and its sensitivity is seen by the results identifying significant problems on longwalls, eg ventilation bypass, goaf over pressurisation, poor water pressure or flow to sprays, etc.

By installing the best practice engineering controls, operators are in a better position to ensure compliance to regulatory standards for exposure levels and most importantly, they are ensuring minimum risk to worker health by ensuring they are mitigating the most respirable and inhalable dust possible from the mining environment.

Dust measurements collected with the DME model indicate that operators struggle to remove greater than 30% of both respirable and inhalable dust produced on their operating longwalls. With the DME model, it is envisaged that a greater than 50% reduction in both respirable and inhalable dust can be achieved with best practice engineering, which will have a direct reduction in exposure levels to workers on the face and significantly reduce the risk of lung disease in employees.

The DME model has quantified the average respirable and inhalable dust production from each known source of dust generation on an operating longwall as a benchmark and with controls operating. The results found the following:

## CHAPTER TEN

### Recommendation and Conclusion

---

- The last open cut-through to the longwall produces an average of 0.0002 mg/tonne of respirable dust and 0.0004 mg/tonne of inhalable dust with no controls operating. With controls operating, the average dust production is 0.0002 mg/tonne for respirable dust and 0.0004 mg/tonne for inhalable dust. These results are expected to be the same as installed engineering controls have no effect on outbye dust into the longwall;
- The belt road produces an average of 0.0002 mg/tonne for respirable dust with no controls operating and 0.0004 mg/tonne for inhalable dust. With controls operating the average dust production is 0.0003 mg/tonne for respirable dust and 0.0003 mg/tonne for inhalable dust. These results show that the installed controls in the belt road, usually sprays at the BSL discharge and ventilation increase the average mg/tonne produced for respirable dust by 50% and reduce the amount of inhalable dust by 25%. This can be explained by the intake velocity drying the coal and allowing respirable particles to become airborne and return to the longwall;
- The BSL discharge produces an average of 0.0003 mg/tonne of respirable dust with no controls operating and 0.0003 mg/tonne for inhalable dust. With controls operating the average dust production is 0.0002 mg/tonne for respirable dust and 0.0008 mg/tonne for inhalable dust. These results show that the installed controls are successfully removing an average of 33% of the produced respirable dust, however, the average inhalable dust production increases by 167%. This is a result of incorrect spray position, orifice size, pressure or flow.
- The maingate produces an average of 0.0004 mg/tonne of respirable dust with no controls operating and 0.0032 mg/tonne for inhalable dust. With controls operating the average dust production is 0.0004 mg/tonne for respirable dust and 0.0009 mg/tonne for inhalable dust. These results show that the installed controls are not removing the produced respirable dust, however, the average inhalable dust production decreases by 72%;

## CHAPTER TEN

### Recommendation and Conclusion

---

- Midface produces an average of 0.0009 mg/tonne of respirable dust with no controls operating and 0.0029 mg/tonne for inhalable dust. With controls operating the average dust production is 0.0011 mg/tonne for respirable dust and 0.0041 mg/tonne for inhalable dust. These results show that the installed controls are creating an average of 22% more respirable dust and an average inhalable dust production increase of 41%; and
- The tailgate produces an average of 0.0011 mg/tonne of respirable dust with no controls operating and 0.0031 mg/tonne for inhalable dust. With controls operating the average dust production is 0.0012 mg/tonne for respirable dust and 0.0042 mg/tonne for inhalable dust. These results show that the installed controls are creating an average 9% more respirable dust and an average inhalable dust production increase of 35%.

These results indicate that the average longwall mining operation in Australia produce an average of 10% more respirable dust when installed engineering controls are turned on. The average inhalable dust production decreases by 6% with the installed controls operating.

The reason behind the average respirable dust production increase is due to the shearer and chock movement creating over 90% of all produced dust on the longwall. Installed engineering controls in the LOC, belt road, BSL discharge and maingate area are reasonably well controlled, but these areas contribute less than 9% of total face dust in the tailgate.

Whilst these results are an average of the respirable and inhalable dust loads measured, the best practice installed engineering controls at each source of dust generation will see improvements in both the respirable and inhalable dust load averages as more mines install these identified controls. Further improvements will be made as more products are quantified in an operational capacity.

## 10.2 Recommendations

The DME model has provided quantifiable data in relation to respirable and inhalable dust load production and installed engineering control efficiencies. The following recommendations have been identified to further validate this model as a valuable and reliable tool to better understand respirable and inhalable dust production and the efficiency of installed engineering controls;

- the use of PDM's for data collection with the DME model used to calculate efficiencies;
- use of the DME model to better understand respirable and inhalable dust production and control in development panels and bord and pillar mining;
- medical research be conducted to understand how much respirable and inhalable dust is actually required to be ingested to create lung problems;
- comprehensive research into the accuracy of current exposure level limits and their suitability to the continually increasing production in the global mining industry;
- continued product measurement to quantify respirable and inhalable dust mitigation efficiency;
- suitability for the DME model to be legislated as an additional method for dust analysis for all mining applications, and;
- further DME testing in open cut mines and hard rock mines to ascertain benchmark dust production and prove adaptability.

By better understanding respirable and inhalable dust production, installed engineering control efficiencies and application of a Best Management Practice to



**CHAPTER TEN**  
Recommendation and Conclusion

---

mitigate airborne contaminants, a significantly healthier workplace and environment will be achieved.

## CHAPTER ELEVEN

### References

---

## CHAPTER ELEVEN - REFERENCES

AS2985–2004, *Workplace atmospheres—Method for sampling and gravimetric determination of respirable dust*, Standards Australia GPO Box 476, Sydney, NSW 2001, Australia

AS3640-2009, *Workplace atmospheres—Method for sampling and gravimetric determination of inhalable dust*, Standards Australia GPO Box 476, Sydney, NSW 2001, Australia

Airborne Dust In Coal Mines Respirable Dust & Quartz Inhalable Dust, (2008). *Coal Services Pty Limited Standing Committee on Dust Research and Control (SDC) has produced this booklet to promote a better understanding of the health effects and control of airborne dust*. Published by Coal Services Pty Limited 2008

American Heritage Dictionary, <http://www.answers.com/topic/brownian-movement>: accessed 11<sup>th</sup> October 2012

Atkinson, T. Thick., (1979). *Steep and Irregular Coal Seam Mining*, University of Nottingham, January 1979

Australian Institute of Occupational Hygienists Inc., (2009). *Respirable Crystalline Silica and Occupational Health Issues*, prepared by AIOH Exposure Standards Committee, February 2009

Baig NA, Dean AT, Skiver DW., (1994). *Successful use of belt washers*. In Proceedings of the American Power Conference. Chicago, IL. Illinois Institute of Technology, pp. 976–978

Balusu, S. R., (1993). “*Design and Development of a Multi-Scrubber Dust Control System for Longwall Faces; Experimental and Modelling Studies*”, Thesis submitted November 1993, University of Wollongong.

Bell, S., Tierman, G., Glassock, A., Arnold, K., O’Regan, D., Milburn, R. and Glover, D., (1993). “*Longwall Dust Control*”, Joint Coal Board Internal Report, pp. 20.

Breyse, Patrick N., Lees, Peter S.J., (2006). *Particulate Matter*, The Johns Hopkins University, School of Public Health, 2006

Canadian Centre for Occupational Health and Safety (CCOHS), *What are the Effects of Dust on the Lungs?*, OSH Answers, Chemicals and Materials, [http://www.ccohs.ca/oshanswers/chemicals/lungs\\_dust.html](http://www.ccohs.ca/oshanswers/chemicals/lungs_dust.html) accessed 17<sup>th</sup> October 2012

CDC, (2003). *Pneumoconiosis prevalence among working coal miners examined in federal chest radiograph surveillance programs--United States, 1996-2002*. MMWR Morb Mortal Wkly Rep 52:336-340.

## CHAPTER ELEVEN

### References

---

CDC, (2006). *Advanced cases of coal workers' pneumoconiosis--two counties, Virginia*, 2006. MMWR Morb Mortal Wkly Rep 55:909-913.

CDC, (2007). *Advanced pneumoconiosis among working underground coal miners--Eastern Kentucky and Southwestern Virginia*, 2006. MMWR Morb Mortal Wkly Rep 56:652-655.

CDC Website, *Coal Workers' Health Surveillance Program - Fall 2008 Update*, <http://www.cdc.gov/niosh/topics/surveillance/ords/CWHSP-News-Fall2008.html> accessed 23<sup>rd</sup> November 2011

Coal Mines Regulation Act 1982

Columbian Encyclopaedia, <http://www.answers.com/topic/brownian-movement>

Cheng, L. and Zukovich, P.P., (1973). “*Respirable Dust Adhering to Run-Of Face Bituminous Coals*”, USBM Report of Investigations 7765, pp10

Cram, K, (2003). *COAL 2003, 13 – 14 February 2003*, University of Wollongong, NSW

Cram K, (2006). *Australian Black Coal Mining Operations*, Longwall 2006, 30 – 31 October 2006, Hunter Valley, NSW. Australia

Department of Health and Human Services, Centers for Disease Control and Prevention, National Institute for Occupational Safety and Health, (2002). *Health Effects of Occupational Exposure to Respirable Crystalline Silica*, NIOSH Hazard Review, DHHS (NIOSH) Publication No. 2002–129, April 2002

Department of Health and Human Services, Centers for Disease Control and Prevention, National Institute for Occupational Safety and Health, (2010). *Best Practices for Dust Control in Coal Mining*, By Jay F. Colinet, James P. Rider, Jeffrey M. Listak, John A. Organiscak, and Anita L. Wolfe, Information Circular 9517, January 2010

Department of Labor Mine Safety and Health Administration 30 CFR Parts 70, 71, 72, et al. (2010). *Lowering Miners' Exposure to Respirable Coal Mine Dust, Including Continuous Personal Dust Monitors; Proposed Rule*, Federal Register, 19<sup>th</sup> October 2010

Douglas FS, (2007). *Selected Health Issues in Mining*, Spokane Research Laboratory, National Institute for Occupational Safety and Health, Spokane, WA and R. Larry Grayson, University of Missouri, Rolla, MO,

ETH (Swiss Federal Institute of Technology) Zurich, (2012), *Air Quality and Aerosol Mechanics*, Spring 2012, D-BAUG – Department of Civil, Environmental and Geomatics Engineering - IfU - MAS\_SWR

## CHAPTER ELEVEN

### References

---

<http://www.ifu.ethz.ch/IE/education/AQAM/AerosolMechanics> - accessed 26th September 2012

Frascati Manual, (2002). *Proposed Standard Practice for Surveys on Research and Experimental Development*, University of Oxford, 11 Dec 2002, OECD Publishing , Sixth edition, 2002, para. 64, page 30.

Gillies ADS and Wu HW, (2001). *Dust Measurement and Control in Thick Seam Mining*, University of Queensland, 2001.

Horiba Scientific., (2010). *A Guidebook to Particle Size Analysis*, Horiba Instruments, Inc, 34 Bunsen Drive Irvine, CA 92618 USA

International Labour Office (1980). *International classification of radiographs of pneumoconiosis 1980 edition*. Occupational Safety and Health Series no. 22 (Rev. 80). Geneva: International Labour Office, pp. 1-48.

International Longwall News, (2010). *Airborne Dust - Inhalable Dust Control - Chief Inspector Safety Bulletins, NSW*, 1 April 2010 SB10-05, [www.longwalls.com/storyview.asp?storyid=1133138&sectionsource=s0](http://www.longwalls.com/storyview.asp?storyid=1133138&sectionsource=s0)

International Longwall News, (2012). *Black lung cases at epidemic scale*, 10<sup>th</sup> July 2012, [www.longwalls.com/storyview.asp?StoryID=9201825&ns=NA](http://www.longwalls.com/storyview.asp?StoryID=9201825&ns=NA)

IUPAC, (1990). *Glossary of atmospheric chemistry terms*. International Union of Pure and Applied Chemistry, Applied Chemistry Division, Commission on Atmospheric Chemistry. *Pure and Applied Chemistry* **62** (11):2167-2219.

Jankowski RA, Colinet JF., (2000). Update on face ventilation research for improved longwall dust control. *Min Eng* 52(3):45–52

Kissell FN, Stachulak JS., (2003). *Underground hard-rock dust control*. In: Kissell FN, ed. *Handbook for dust control in mining*. Pittsburgh, PA: U.S. Department of Health and Human Services, Centers for Disease Control and Prevention, National Institute for Occupational Safety and Health, DHHS (NIOSH) Publication No. 2003-147, IC 9465, pp. 83–96

Kuempel ED, Smith RJ, Attfield MD, Stayner LT., (1997). *Risks of occupational respiratory diseases among U.S. coal miners*. *Appl Occup Environ Hyg* 12:823-831.

Laney AS, Attfield MD., (2010). *Coal workers' pneumoconiosis and progressive massive fibrosis are increasingly more prevalent among workers in small underground coal mines in the United States*. *Occup Environ Med* 67:428-431.

Lippmann, Morton., *Morphometry, Cytology, Histology, function and Structure of the Respiratory Tract*, Chapter 10, Structure and Function, International Labor Organisation.

[http://www.ilo.org/safework\\_bookshelf/english?content&nd=857170097](http://www.ilo.org/safework_bookshelf/english?content&nd=857170097): accessed 20<sup>th</sup> December 2012

## CHAPTER ELEVEN

### References

---

Mace G, (2008). *Australian Longwall Mines Coal Production and Coal Production Accident Performance and Airborne Dust and Quartz Results*, 2008

McAteer DJ, (2010). *The Upper Big Branch April 5, 2010, explosion: a failure of basic coal mine safety practices*, Report to the Governor, Governor's Independent Investigation Panel, April 2010

McDonnell I, (2009). *Dust Control on Longwall Faces by Fine Mist (Atomising) Sprays - Can They Really Work?* Faculty of Engineering Coal Operators' Conference University of Wollongong 2009

McPherson, Malcolm J., (2009). *Subsurface Ventilation and Environmental Engineering*, Part 5 Dust, Chapter 19, The Hazardous Nature of Dusts, 2nd ed, Chapman & Hall, 2009.

Michigan Tech Mechanical Engineering, *Principal Mechanisms of Respiratory Deposition*, <http://www.mfg.mtu.edu/cyberman/environment/air/depos.html> accessed 9th October 2012

MörTERS, Peter., and Peres, Yuval., *Brownian Motion*, with an appendix by Oded Schramm and Wendelin Werner  
[www.research.microsoft.com/en-us/um/people/peres/brbook.pdf](http://www.research.microsoft.com/en-us/um/people/peres/brbook.pdf) accessed 9th October 2012

Mosby's Medical Dictionary, 8th edition. 2009, Elsevier, <http://medical-dictionary.thefreedictionary.com/inertial+impaction> accessed 9<sup>th</sup> October 2012

MSHA, (1989). *Belt entry ventilation review: report of findings and recommendations*. Arlington, VA: U.S. Department of Labor, Mine Safety and Health Administration

MSHA, *End Black Lung Now*, 2009,  
<http://www.msha.gov/S&HINFO/BlackLung/homepage2009.asp>: accessed 9<sup>th</sup> October 2012

National Center for Biotechnology Information (NCBI), *Coal Worker's Pneumoconiosis*, U.S. National Library of Medicine 8600 Rockville Pike, Bethesda MD, 20894 USA, <http://www.ncbi.nlm.nih.gov/pubmedhealth/PMH0001187/> accessed 17<sup>th</sup> October 2012

National Institute for Occupational Safety and Health, (1995). *Criteria for a recommended standard: Occupational exposure to coal mine dust*. DHHS (NIOSH) Publication No. 95-106. Washington, DC, National Institute for Occupational Safety and Health.

NIOSH, (2008). *Work-related lung disease surveillance report 2007, Volume 1. DHHS (NIOSH) Publication No. 2008-143a*. Cincinnati, OH, National Institute for Occupational Safety and Health.

## CHAPTER ELEVEN

### References

---

NIOSH, (2010). Department of Health And Human Services Centers for Disease Control and Prevention National Institute for Occupational Safety and Health Office of Mine Safety and Health Research, *Best Practices for Dust Control in Coal Mining*, IC 9517 Information Circular/2010

National Institute for Occupational Safety and Health (2010). *Work-related lung disease (WORLD) surveillance system*. <http://www2a.cdc.gov/drds/WorldReportData/>

NSW Department of Investment and Industry, (2004). *New South Wales Government Gazette* No. 200, 7 December 2004, File No: C99/0691

ORC Experts,

<http://www.orcexperts.co.uk/experts.asp?strSearchType=all&strQuery=electrostatic+deposition> accessed 9<sup>th</sup> October 2012

Organiscak JA, Reed WR., (2004). Characteristics of fugitive dust generated from unpaved mine haulage roads. *Int J Surface Min Reclam Environ* 18(4):236–252

Organiscak JA, Page SJ, Cecala AB, Kissell FN., (2003). Surface mine dust control. In: Kissell FN, ed. *Handbook for dust control in mining*. Pittsburgh, PA: U.S. Department of Health and Human Services, Centers for Disease Control and Prevention, National Institute for Occupational Safety and Health, DHHS (NIOSH) Publication No. 2003-147, IC 9465, pp. 73–81

Organiscak JA, Jankowski RA, Kelly JS., (1986). Dust controls to improve quality of longwall intake air. Pittsburgh, PA: U.S. Department of the Interior, Bureau of Mines, IC 9114. NTIS No. PB 87-167573

Pabst, W., Gregorová E., (2007). *Characterization of Particles and Particle Systems*, ICT Prague 2007, FRVŠ 674/2007 F1 / b

Park, Ju-Hyeong., (2012). *Impactors and Particle Size Distribution*, National Institute for Occupational Safety and Health Division of Respiratory Disease Studies Field Studies Branch

Rider JP, Colinet JF., (2006). *Benchmarking Longwall Dust Control Technology and Practices*, National Institute for Occupational Safety and Health, Pittsburgh, PA

Rutherford A, (2003). *Report on Dust Generation and Effectiveness of Suppression Techniques used on Longwall BSL and Crushers*, Coal Services Grant Research, Submitted November 2003.

SIMTARS, BMA Coal Operations Pty Ltd Broadmeadow Mine, Respirable Dust Survey Report No: OM16024F5, SIMTARS FILE REFERENCE: 50/010/0001/60/24, 7 December 2009

## CHAPTER ELEVEN

### References

---

Smith DR, Leggat PA., (2006). *24 years of pneumoconiosis mortality surveillance in Australia*. J Occup Health 48:309-313.

The Engineering Toolbox [http://www.engineeringtoolbox.com/particle-sizes-d\\_934.html](http://www.engineeringtoolbox.com/particle-sizes-d_934.html) Accessed 23rd August 2012

United States Environmental Protection Agency, *BCES Module 3: Characteristics of Particles - Collection Mechanisms*, <http://www.epa.gov/apti/bces/module3/collect/collect.htm> accessed 9th October 2012

United States Department of Labor., (2008). *Dust Control Handbook for Mineral Processing*, Occupational Health and Safety Administration, Chapter 1, Contract No. J0235005, Martin Marietta Corporation, Martin Marietta Laboratories, 1450 South Rolling Road Baltimore, MD 21227-3898

U.S. Department of Labor, Mine Safety and Health Administration., (2008). *A Practical Guide to an Occupational Health Program for Respirable Crystalline Silica*, Instruction Guide Series IG 103, Jan 25, 2008

US Department of Labor., (1996). *Report of the Secretary of Labor's Advisory Committee on the Elimination of Pneumoconiosis among Coal Mine Workers*. Washington, DC: US Department of Labor

World Health Organisation., (1999). *Hazard Prevention and Control in the Work Environment: Airborne Dust*, WHO/SDE/OEH/99.14

World Health Organisation., (1984). *Evaluation of Exposure to Airborne Particles in the Work Environment*, Geneva 1984, WHO Offset Publication No. 80, Printed in Switzerland, 83/5934 - Imprimeries Populaires - 4500

World Health Organization International Agency for Research on Cancer., (1997). *IARC Monographs on the Evaluation of Carcinogenic Risks to Humans*, Volume 68, Silica, 20<sup>th</sup> May 1997

Appendix 1

Mine Questionnaire

University of Wollongong		
<b>(Research-In-Confidence)</b>		
<b><u>Australian Longwall Mine Dust Control Data Survey</u></b>		
<b><u>Ventilation</u></b>		
1	Ventilation at last open cut through	
2	Ventilation at maingate	
3	Ventilation midface	
4	Ventilation at tailgate	
<b><u>Sprays</u></b>		
5	Number of sprays in BSL discharge	
6	Type of sprays in BSL discharge	
	Solid cone	
	Hollow Cone	
	Flat Spray	
	V Spray	
	Spray Diameter	
	Water Pressure	
	Water Flow	
7	Number of sprays in BSL	
8	Type of sprays in BSL	
	Solid cone	
	Hollow Cone	
	Flat Spray	
	V Spray	
	Spray Diameter	
	Water Pressure	
	Water Flow	
9	Number of sprays in BSL crusher	
10	Type of sprays in BSL crusher	
	Solid cone	
	Hollow Cone	
	Flat Spray	
	V Spray	
	Spray Diameter	
	Water Pressure	
	Water Flow	
11	Number of sprays in shearer drums	
12	Type of sprays in shearer drums	
	Solid cone	
	Hollow Cone	
	Flat Spray	
	V Spray	
	Spray Diameter	
	Water Pressure	
	Water Flow	
13	Number of sprays in shearer clearer	
14	Type of sprays in shearer clearer	
	Solid cone	
	Hollow Cone	
	Flat Spray	
	V Spray	
	Spray Diameter	
	Water Pressure	
	Water Flow	
15	Number of Shield Sprays	
16	Types of Shield Sprays	
	Solid cone	
	Hollow Cone	
	Flat Spray	
	V Spray	
	Spray Diameter	
	Water Pressure	
	Water Flow	
17	Other Dust Controls Used?	
	Type	
18	Shearer drum speed	
19	Cutting Height	
20	Face Length	
21	Face Width	
22	Shearer Speed	
23	Av. Shears per Shift	
24	Av. Tonnes per Shear	
25	Cutting Sequence	
	Bi-Di	
	Uni-Di	
26	Maingate Goaf Curtain Used?	
27	BSL Curtain Used?	
28	How bad is your dust problem?	
	1 being good, 10 being bad	
29	Do you have a stone roof?	
30	Do you have a stone floor?	
Note:		



Coal Services Pty Limited

ORDER No. 40  
LONGWALL DATA

COLLIERY:

DISTRICT:

LONGWALL No:

COMENCEMENT DATE:

ANTICIPATED FINISHING DATE:

Seam:            Seam Height:            No. Of Chocks:

	<u>LAST LONGWALL</u>	<u>NEW LONGWALL</u>
Length of Face:		
Length of Block:		
Output per Shift:		

VENTILATION

Airflow:

Anticipated Face Quantity (m<sup>3</sup>/s):

BEAM STAGE LOADER

Structure:

Cover Material:

Discharge End:

Material Used at Discharge End:

Spray Access (BSL to Boot End)

Sprays Visible:

Sprays Easily Checked:

Spray Type:

Total No. Off sprays:

Sprays:

CRUSHER

Pick Type:

Spray Types in Use:

No. of Sprays on Crusher:

Sprays Accessibility:

Dust Extractor Fitted:

Curtain Fitted at Crusher Entry:

Material Used for Curtain:

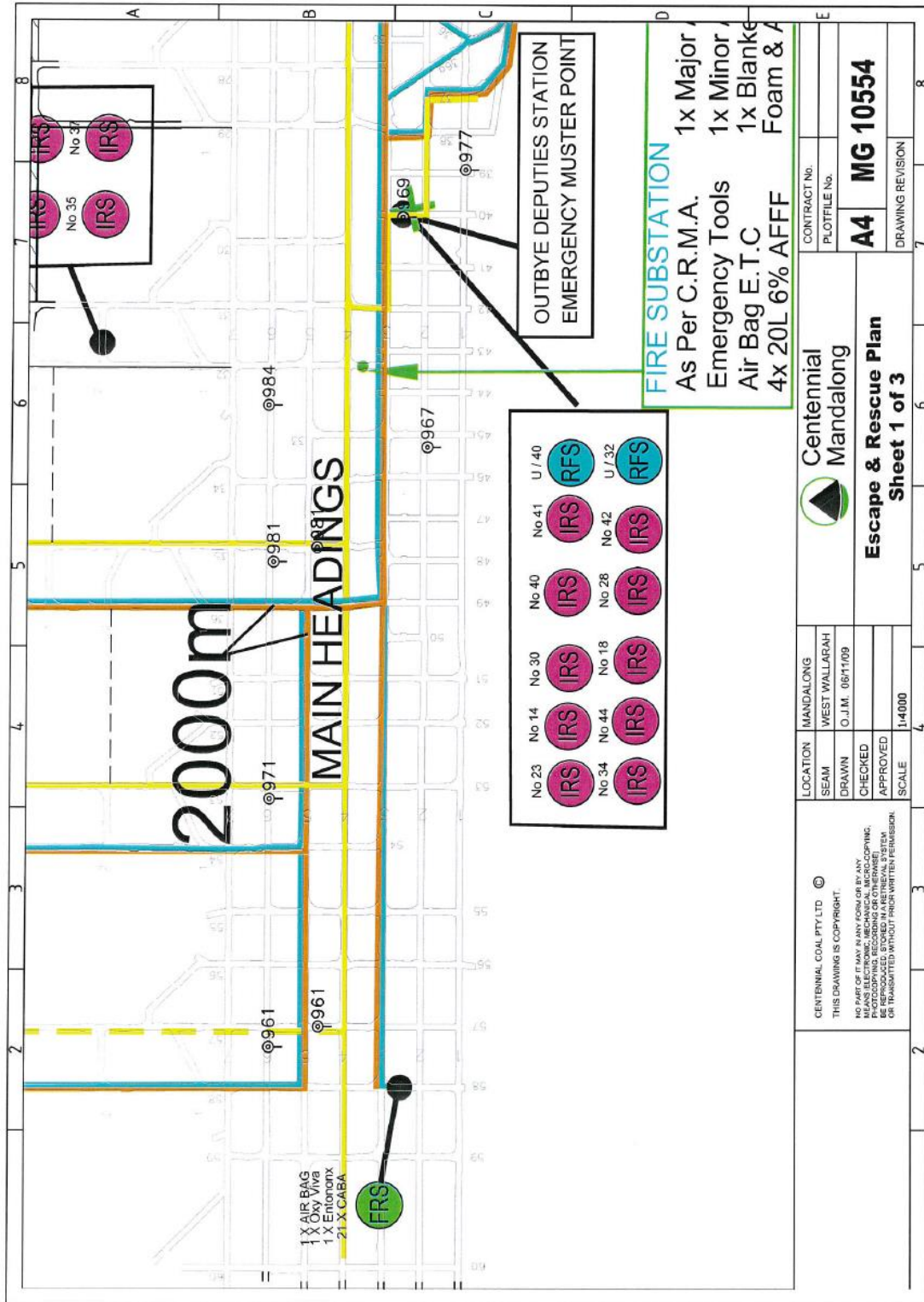
Crusher R.P.M.:

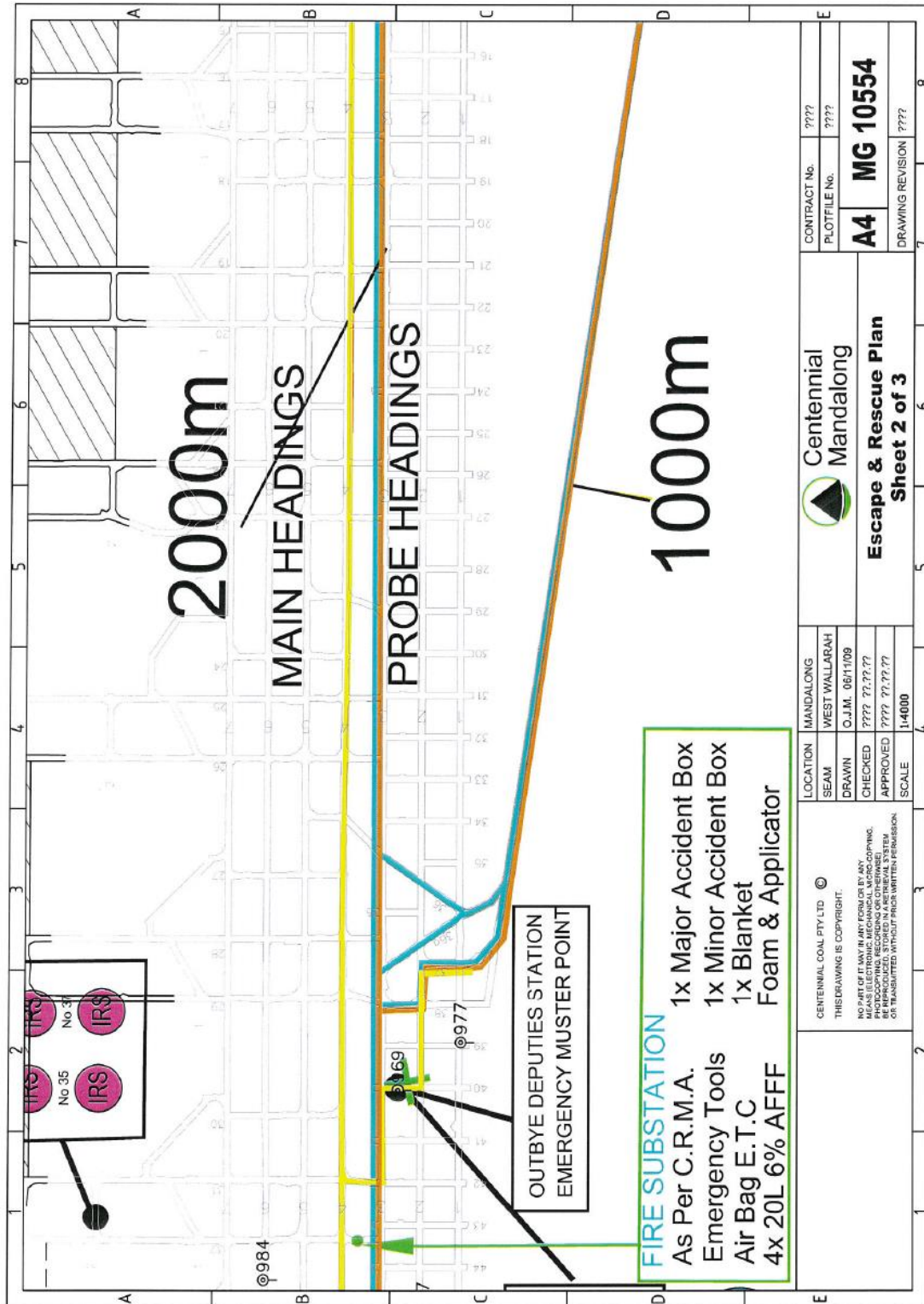
# UNDERGROUND

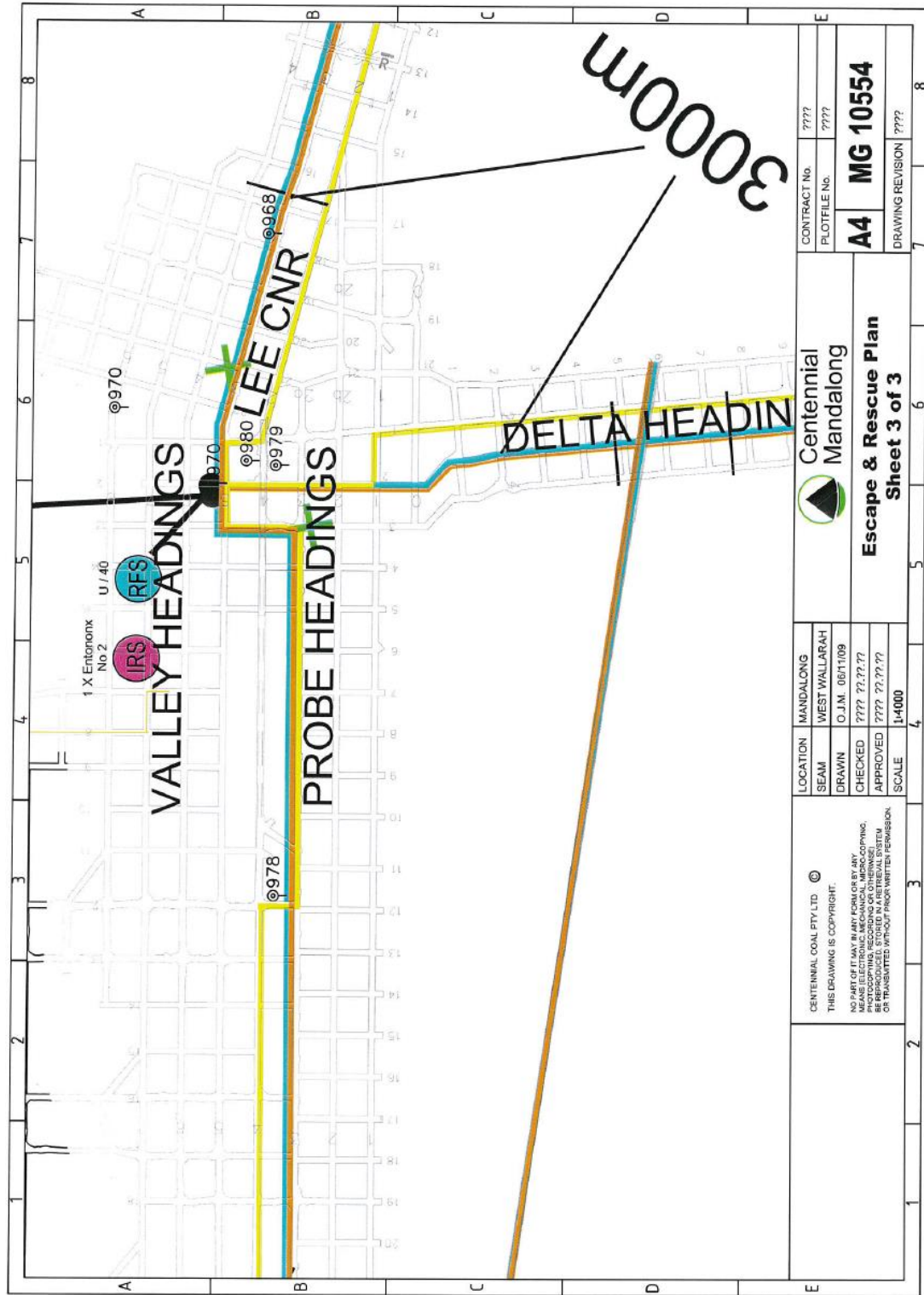
 InductionLink

 InductionLink

53A Westcourt Rd New Lambton 2305 / ABN 69 127 816 013  
T: 02 4957 1108 / M: 0411 266 215 / F: 02 4957 1106 / [admin@inductionlink.com.au](mailto:admin@inductionlink.com.au)  
[www.inductionlink.com.au](http://www.inductionlink.com.au)

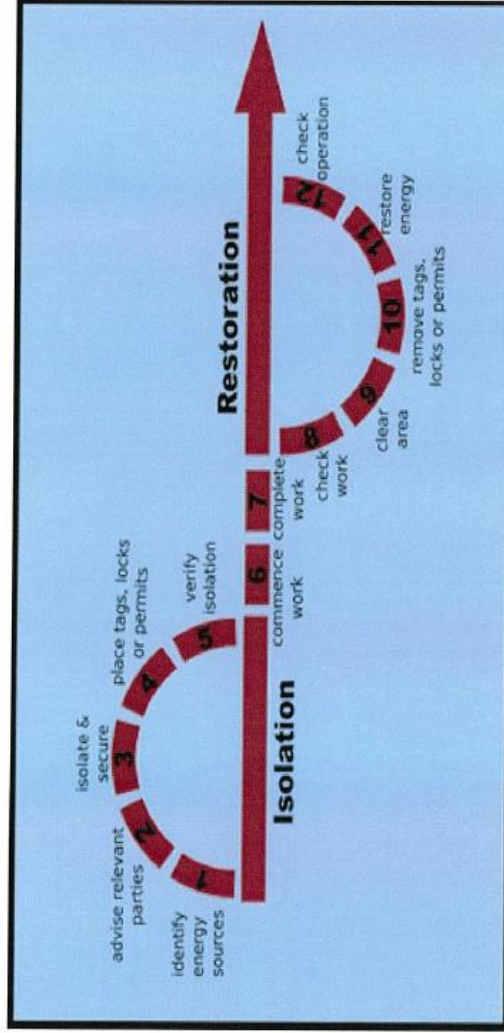






CENTENNIAL COAL PTY LTD © THIS DRAWING IS COPYRIGHT. NO PART OF IT MAY BE REPRODUCED BY ANY MEANS (ELECTRONIC, MECHANICAL, MICRO-COPYING, PHOTOCOPYING, RECORDING, OR BY ANY INFORMATION STORAGE AND RETRIEVAL SYSTEM) WITHOUT PERMISSION OR TRANSMITTED WITHOUT PRIOR WRITTEN PERMISSION.	LOCATION: MANDALONG SEAM: WEST WALLARAH DRAWN: O.J.M. 08/11/09 CHECKED: ????.???.?? APPROVED: ????.???.??	CONTRACT No. ???? PLOT FILE No. ????
	SCALE: 1:4000	A4 MG 10554

## THE TWELVE STEP PROCESS



- Used by most other Mine Operators and Heavy Industry
- All Isolation Procedures are formatted to follow the 12-step process.

## TYPES OF ISOLATION (cont'd)

### Group Isolation

This Isolation:

- Requires the use of a permit
- Must be used where the size of the work party exceeds eleven, or
- The number of isolation points exceeds two, or
- The individuals doing the task are not confident they can carry out the isolation as an individual isolation, or
- Is has been decided the risks and complexity involved in the task make it necessary to do a Group Permit, and
- The task does not involve work on High Voltage Apparatus

For both Individual and Group Isolations – the “12 Step” Isolation Process must be followed

### High Voltage Isolation

At Mandalong Mine High Voltage Isolation will be undertaken using procedures detailed in the Std of Eng Practice for High Voltage Systems

## TAGS

### Personal Danger Tag

- The Control of Energy Management Plan requires that locks are used to effect isolation.
- However it is acknowledged that there may be times where it is impractical to apply a lock. *Losing a lock is not a valid reason for applying a Danger Tag in its place.*
- Danger tags should only be applied where there is no provision at all for locking.
- A Danger Tag should always be attached to Primary Isolation Device (an isolator that directly isolates the energy source).
- Must not be attached to auxiliary device (eg Stop Button).
- Personnel must not **attach** or **remove** another persons' Danger Tag.
- Personnel must not operate any switch or device that has a Danger Tag fitted.
- Personnel must remove their Danger Tag at the end of a job.
- Another persons lock can only be removed by following the Danger Tag Removal Procedure (P-1406).
- If you leave your Tag on you may be asked to come back to remove it.





## TAGS (cont'd)

### Out of Service Tag

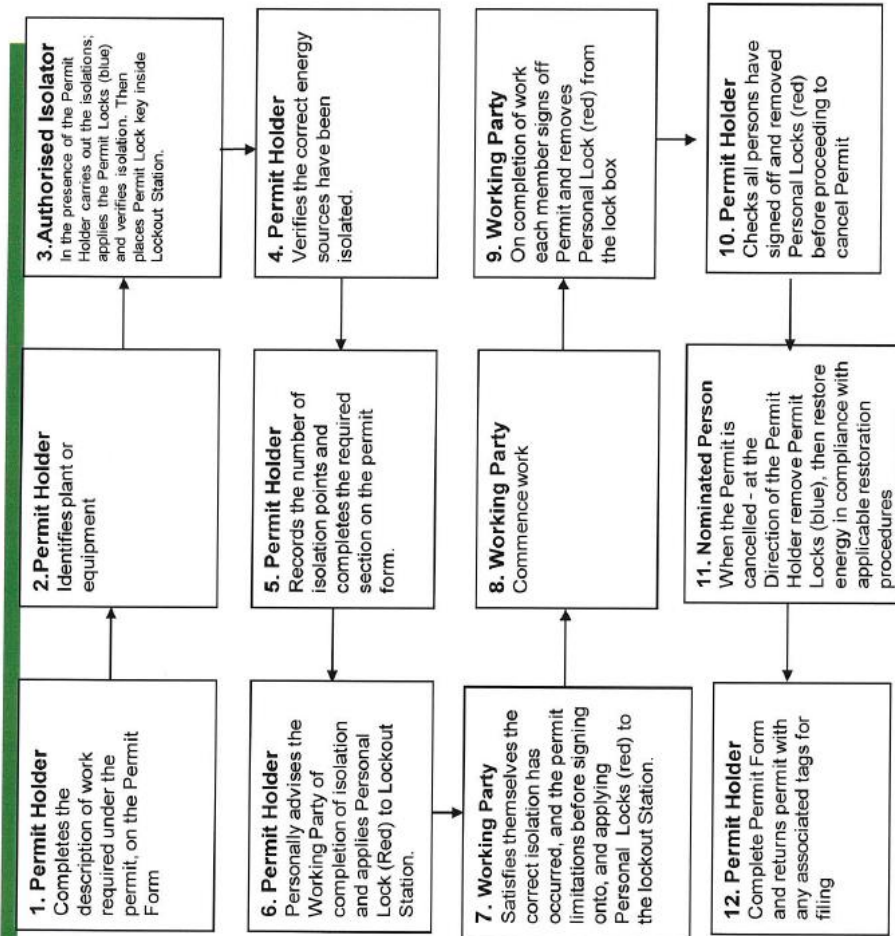
- These Tags are used to advise personnel that a piece of plant is out of service and cannot be operated due to some form of defect or malfunction.
- An Out of Service Tag may be fitted by any person who thinks the equipment could injure people or suffer further damage.
- Equipment with an Out of Service Tag must not be operated except by personnel who are repairing the equipment or fault-finding on it.

To fit an Out of Service Tag:

- Isolate the equipment
- Fill out the Tag correctly
- Apply the Tag to the machine isolator – ensuring the tag is visible
- Inform your Supervisor, and give them the tear off section of the Tag – the tear off section is to be presented to a Shift Leader, or put into the box beside the Control Room Door for further actioning (Refer to MS-1004 Defect Management System for further details).
- An out of Service Tag can only be removed by the person completing the work to make it fit for service, or an appropriate Supervisor who has ensured the machine is fit for service.



## GROUP ISOLATION FLOW-CHART



# GROUP ISOLATION PERMIT

PERMIT HOLDER TO COMPLETE

AUTHORISED ISOLATOR TO COMPLETE

PERMIT HOLDER TO COMPLETE

<b>Centennial Mandalong Mine – Group Isolation Permit</b>	
Description of Work to Be Undertaken:	
Isolation Points (all isolation points to be listed):	LOCK-BOX ID:
<b>Authorised Isolator:</b> I verify the above isolation is correct, that all locks have been correctly affixed, and that it is safe for the above-mentioned work to proceed. Name: _____ Signature: _____ Date: _____	
<b>Permit Holder (if not Authorised Isolator):</b> I accept this permit and I am satisfied that the above isolation is correct, and the equipment mentioned in the Description of Work is safe to work on. Name: _____ Signature: _____ Date: _____	
<b>Transfer of Permit (if required – not to be used to transfer between shifts):</b> <b>Old Permit Holder:</b> I relinquish control of this permit, and have understood the terms of work, and the scope of the isolation. Name: _____ Signature: _____ Name: _____ Signature: _____	
<b>Work Party:</b> By signing on, I perform and acknowledge that the isolation is correct and understood. Name: _____ Sign Off: _____	
<h2>WORK PARTY TO SIGN ON AND OFF</h2>	
<b>Cancellation of Permit:</b> I cancel this permit, and have confirmed that all personnel have signed off the Permit, that all locks have been removed, and the Isolator in charge of the permit has been advised to the agreement. Name: _____ Signature: _____ Date: _____	

---

## PERMITS (cont'd)

### Group Isolation Permit - Requirements

- Requires an **Authorised Isolator** and a **Permit Holder**.
- **Authorised Isolator** and **Permit Holder** cannot be the same person.
- **Authorised Isolator** – Carries out the isolation – in the presence of the Permit Holder. If they are a member of the work party, also signs-on as a member of the work party. The Authorised Isolator does not have to remain at the work site once the isolation is complete. Only personnel who have completed the Group Isolation Training Assessment will be permitted to act as Authorised Isolators. Apprentices will not be trained or appointed as Authorised Isolators.
- **Permit Holder** – Controls Permit - Verifies isolation is correct, advises work party of details of isolation before they sign on. The Permit Holder can remove the isolation on cancellation of the permit, or assign another person to do so.

**PERMITS (cont'd)**  
 Group Isolation Permit – Requirements (cont'd)

- **Work Party** - All personnel working on the job must sign on the permit, and attach their Personal Lock to the Lockout Station. Personnel do not have to have completed the Group Isolation Assessment to sign on as a member of the work party.
- Personnel are not permitted to sign anyone else ON or OFF the permit.
- Personnel joining the work party at a later time must contact the Permit Holder and have the isolation explained to their satisfaction prior to applying their lock to the lockout station and signing on the permit.
- Personnel are not permitted to place or remove another persons locks on the Lock Out Station.
- The lockout station is to be kept close to the work site, with the Permit stored on the front – to provide ready access for personnel.

## PERMITS (cont'd)

### Group Isolation Permit – Requirements (cont'd)

- Where the number of people exceeds the available space on the permit, a second permit sheet should be completed and kept with the first, and the extra personnel sign on the second sheet.
- Permits can be transferred between personnel – should the Permit Holder have to leave the work site.
- Permits cannot be transferred between shifts – each shift must apply their own isolation. *However this does not apply if the Permit Holder is staying back to work on the next shift. In this case the oncoming crew can apply locks and sign on after the isolation has been explained and demonstrated – and the permit holder can then transfer the permit at the end of their overtime shift.*
- On leaving the work site, all personnel must sign-off the Permit, and remove their Personal Lock from the Lockout Station.

## PERMITS (cont'd)

### Group Isolation Permit – Requirements (cont'd)

- On completion of the work, the Permit must be cancelled, and all locks returned to the lockout station.
- A person who is trained in the Control of Energy Management Plan can restore energy on the cancellation of a permit, at the direction of the Permit Holder. This includes the Permit Holder themselves.
- If the equipment is not ready to be returned to service, an Out of Service Tag must be fitted to the isolation point.
- Where separate work parties are working at remote locations on the same piece of equipment, a group isolation will be required for each party.
  - e.g. Conveyor maintenance team working at drivehead, and Longwall personnel working on boot-end will require a separate Group Isolation Permit for each party. This means a lock box at each work site, and two sets of blue locks on the conveyor isolation points.

---

## **ISOLATION OF HIGH PRESSURE SYSTEMS**

- Isolation of High Pressure systems (working pressure greater than 5MPa) will be carried out in accordance with the Mines Standard of Engineering Practice for Fluid Power systems.
- It is vital that only persons with the relevant training undertake the isolation of these systems.
- Personnel shall only isolate a high pressure circuit after suitable training and familiarisation on the specific item of plant they are working on.
- Other Personnel working on these systems, and needing to confirm the equipment is isolated correctly, must get a Mechanical Tradesman to prove the equipment is safe to work on.






Centennial  
Mandalong



## **Mandalong Health and Safety Management System U/G Transport Management Plan**

### **Safe Vehicle Operation**

- The Undermanager will delegate machines at the start of every shift
- All diesel vehicles must be accounted for within their designated work area.
- Before any machine and/or attachment leaves a district, the Deputy in charge of that district and Control room must be notified
- A transport vehicle shall not exceed the maximum speed limit of 30kph.
- No vehicle shall pass another moving vehicle
- Where a vehicle is being loaded other vehicles must maintain a 10.0m radius exclusion zone from the loading area



Centennial  
Mandalong

---

**Mandalong Health and Safety  
Management System  
U/G Transport Management Plan**

**Safe Vehicle Operation**

- Where a vehicle is self loading other vehicles must maintain a 2.0m radius exclusion zone from the loading area
- When connecting up an LHD QDS attachment the driver must ensure that a 2.0m exclusion zone to personnel is maintained around the attachment whilst the machine is operating.
- A vehicle operator must not load toward other operators unless there is no other option available, in which case a Job Safety Analysis will be required and procedure developed.
- The driver shall not leave the engine of any diesel vehicle running while the vehicle is stationary except:
  - During brief halts which is part of the normal operation of the vehicle.
  - While the vehicle or exhaust gases are being tested.
  - For maintenance purposes.
  - During operations involving the vehicles' hydraulic power take-off



## Mandalong Health and Safety Management System U/G Transport Management Plan

### Safe Vehicle Operation – drift and traffic control

**GREEN** - Drift clear for normal use displayed continuously while normal operations are taking place.

**FLASHING GREEN** - Warning - Indicating a condition of danger, oil spillage, broken down machine in drift, material spillage on roadway **Contact the Control Room.**

**RED** - Men conducting work or undertaking repairs Wide or Heavy Load being transported. **Do not enter.**

**FLASHING RED** - Emergency situation  
**Contact the Control Room before entering.**



## Mandalong Health and Safety Management System U/G Transport Management Plan

### Safe Vehicle Operation – Mandalong Drift

- All vehicles going down the drift are to use **2nd gear** for the full length of the drift journey.
- A vehicle travelling out of the mine up the drift may pass a slower moving vehicle travelling out of the mine. The vehicle must sound their horn before overtaking and the slower vehicle **must come to a stop**.
- LHD machines transporting materials or supplies by bucket or forks shall always be operated in the drift with the **bucket or forks on the high (up dip) side**.
- The maximum width for a normal load shall **not exceed 3.0 meters**. If loads **wider than 3.0 meters** are to be transported, the provisions of the Wide Load Procedure shall be applied



Centennial  
Mandalong


# Mandalong Health and Safety Management System U/G Transport Management Plan

## Safe Vehicle Operation – Parking

- The driver shall, before leaving a vehicle, park the vehicle in a location where there is no risk of vehicle movement causing injury to personnel and ensure that:
  - The vehicle is reversed parked into a crib room leaving sufficient room to enter the vehicle in the case of an emergency.
  - Not to enter any cut-through if personnel are standing at rear of the transport between vehicle and any stationary object
- The park brake is applied and the vehicle is secured against movement by turning the vehicle toward the rib or chocking the wheels, and
- If the machine is fitted with a bucket, blade or other attachments, the attachment is lowered to the floor



Centennial  
Mandalong



# Mandalong Health and Safety Management System U/G Transport Management Plan

## Safe Vehicle Operation – Refueling

- Refuelling of diesel vehicles underground must be carried out in the designated Diesel bay/s, however if a diesel vehicle has run out of fuel or is likely to before reaching the underground diesel bay then “JERRY CANS” may be used.
  - Jerry Cans may only be used under the following conditions when a vehicle is out of fuel:
    - Shift Undermanager approval
    - An Approved Jerry Can – Yellow in Colour
- Jerry Can must be immediately returned to diesel bay



Centennial  
Mandalong



# Mandalong Health and Safety Management System U/G Transport Management Plan

## Safe Vehicle Operation – Gas Testing Monitoring Equipment

- A driver shall not drive a diesel vehicle into a return airway or past the Longwall crib room unless it is equipped with a methanometer with an audible or visual alarm set to alarm at 1% methane.
- In the event of the methanometer alarm being sounded the driver shall ensure that:
  - (a) if it is safe to do so—the plant is withdrawn to an intake airway, or
  - (b) if it is not safe to withdraw it to an intake airway the machine is to be shut down, and that a Deputy made aware of the occurrence of the alarm
- When becoming aware of a stoppage of the main ventilating fan the vehicle operator shall drive to the intake airway, park the vehicle in a cut through or location off the main travelling road. Notify the control room of the vehicle position. The use of man transporters to transport persons to the surface is allowed under supervision of the Undermanager on shift



Centennial  
Mandalong

---

# Mandalong Health and Safety Management System

## U/G Transport Management Plan

### LHD QDS – Attachments

- When connecting up an LHD QDS attachment the driver must ensure that a 2.0m exclusion zone to personnel is maintained around the attachment whilst the machine is operating.
- The driver shall visually inspect and check that the tongue locking device is in place locking the attachment.
- A LHD with an attachment shall be carried in the lowered position
- The machine shall not be overloaded.
- The driver only shall ride on the machine. No person shall be carried in the bucket of the machine.
- The machine shall not be articulated with an elevated, fully loaded attachment.
- The machine shall not be operated unless a door is fitted to the access opening to the driver's compartment.
- LHDS with “man basket attachments” are not to be used as transport vehicle.
- LHDS have accumulators that retain hydraulic energy when the machine is turned off. This is discharged by moving the steering wheel or operating other hydraulic functions.




# Mandalong Health and Safety Management System U/G Transport Management Plan



## Provisions for persons working or travelling on transport roads

- Persons working on any section of a designated travelling road shall:-
- Install flashing lights and signs 20m on either side of the working area (and in view of the workmen).
- Wear reflective clothing – eg. Vests
- Notice will be given to all employees of the work being carried out at the start of shift address.
- Persons working along a designated transport road must be authorised by the shift senior mining supervisor.



Centennial  
Mandalong

# Mandalong Health and Safety Management System

## U/G Transport Management Plan

### **Pedestrians have the right of way**

- An operator must sound the horn and stop the vehicle within 10m of a pedestrian, allowing safe passage for walking personnel.
- Pedestrians must not approach a moving vehicle before attracting the attention of the driver and must endeavour to find a place of safety as a vehicle approaches.
- An exclusion zone of 2.0m is to be observed around a diesel machine whilst in motion, a person may only access the area when the operator has stopped the machine and the park brake has been applied.
- The area between a LHD and a coal rib is a designated exclusion zone whilst a vehicle is in motion.
- No person is to pass a moving vehicle unless positioned in a place of safety.



Centennial  
Mandalong

# Mandalong Health and Safety Management System U/G Transport Management Plan

## Maximum Towing Capacity and Loads

EQUIPMENT	Pay Load Capacity (ton)	Max. Unbraked Trailer Towing	Max. braked Trailer Towing (tonnes)
EIMCO 913	5.44t	5.5t	8.4t
EIMCO 130	7.0t	7.0t	29.5t
EIMCO ED 10	10.0t (with bucket 8.7t)	8.5t	31.1t
EIMCO ED 7	7.0t	7.0t	29.5t
EIMCO 936	30t @ 1800mm from fork face	26.3t	26.3t
FBL - MH40	40t	20.0t	
MYNE DOZER	Forks – Lift 20.0t (continuous) 42.0t (peak) at centre of tynes Jib – lift 17.0t (retracted) 13.0t (extended) Jib – Slew 22.9t Jib Extend 24.9t Jib Retract 24.9t		



*Austar Coal Mine Pty Ltd*

**LONGWALL  
HYDRAULIC  
SAFETY  
TRAINING COURSE**



LONGWALL ADVANTAGE

**(ASSESSMENT & QUESTIONNAIRE)**



Austar Coal Mine Pty Ltd

**LONGWALL HYDRAULIC TRAINING COURSE  
(TRADESMAN)**

**ASSESSMENT**

**TRAINEE:** Brian Pugh.....

**POSITION:**.....

**MINE SITE:** AUSTAR.....

**LEARNING OUTCOME RESULTS:**

RESULT	"C"	"N.Y.C"	TRAINEE'S SIGNATURE	DATE
LEARNING OUTCOME 1				
LEARNING OUTCOME 2				
LEARNING OUTCOME 3				
LEARNING OUTCOME 4				
LEARNING OUTCOME 5				
LEARNING OUTCOME 6				
LEARNING OUTCOME 7				

**DEFENITIONS:** "C" = COMPETENT  
"N.Y.C" = NOT YET COMPETENT

**7.1 LEARNING OUTCOME 1**

The trainee will receive information required to realize the injuries and dangers associated with high pressure.

**Assessment Criteria:**

The trainee will be asked to complete in their own hand writing, 5 questions on the topic 7.1 Injuries and Dangers associated with high pressure.

**7.2 LEARNING OUTCOME 2**

The trainee will receive information required to recognize system pressure and stored pressure circuits.

**Assessment Criteria:**

The trainee will be asked to complete in their own hand writing, 2 questions on the topic 7.2 Pressure and Stored Energies.

**7.3 LEARNING OUTCOME 3**

The trainee will receive information required to Isolate, Dissipate and Test for Dead system pressure and stored pressure circuits.

**Assessment Criteria:**

The trainee will be asked to complete in their own hand writing, 5 questions on the topic 7.3 Isolation, Dissipation, Test for Dead and Special Tools.

**Assessment Criteria:**

The trainee will be asked to demonstrate on 2 different circuits how to Isolate, Dissipate and test for Dead using the demonstration board.

**Assessment Criteria:**

The trainee will be asked to demonstrate how to Dissipate pressure using a Conflow Adaptor and fitting on the demonstration board.

**7.4 LEARNING OUTCOME 4**

The trainee will receive information and watch a video, enabling them to recognize Hydraulic Intensification of a cylinder.

**Assessment Criteria:**

The trainee will be asked to complete in their own hand writing, 2 questions on the topic 7.4 Hydraulic Intensification.

**7.5 LEARNING OUTCOME 5**

The trainee will receive information required to recognize Staple failures in hydraulic circuits and Controls in place.

**Assessment Criteria:**

The trainee will be asked to complete in their own hand writing, 5 questions on the topic 7.5 Hydraulic Staples.

**Assessment Criteria:**

The trainee will be asked to identify 3 incorrect staples on the demonstration board.

**7.6 LEARNING OUTCOME 6**

The trainee will receive information and watch a video, enabling them to recognize Hydraulic Hose failures and Controls in place.

**Assessment Criteria:**

The trainee will be asked to complete in their own hand writing, 4 questions on the topic 7.6 Hydraulic Hose.

**7.7 LEARNING OUTCOME 7**

The trainee will receive information enabling them to understand Rules and Regulations in place on mine site.

**Assessment Criteria:**

The trainee will be asked to complete in their own hand writing, 2 questions on the topic 7.7 Rules and Regulations.



## QUESTIONNAIRE

TRAINEE NAME: BRIAN PLUSI

DATE: 15.8.2012

MINE SITE: AUSTAR

POSITION: .....

ASSESSOR NAME: MICK BAILEY

### ASSESSMENT CRITERIA:

All questions are to be answered in legible hand writing and are considered critical to the assessment criteria for this training course.



7.1 Injuries and Dangers Associated with High Pressure. Pages 8 -10

Question 1

List 3 injury categories associated with High Pressure?

- A1... Minor.....
- A2... Major.....
- A3... Fatal.....

Question 2

What is the minimum system pressure a pressure injection can occur?

- A1... 10 Bar, 150 PSI.....
- .....

Question 3

List 3 substance categories that can cause a pressure injection?

- A1... Gases.....
- A2... Liquids.....
- A3... Semi Solids.....

Question 4

List 4 dangers associated with Longwall hydraulic equipment?

**A**

**Any 4 of the below**

- Never use your fingers to search for fluid leaks on Longwall Equipment in hard to see areas.
- Never use hydraulic fluids for rinsing or cleaning. Hydraulic fluids represent a very serious danger to health.
- Incorrect identification of circuits, components and isolation points.
- Insufficient or Incorrect isolation and pressure dissipation.
- Be aware that there are POCV's in circuits that store or lock pressure/energy in cylinders and circuits.
- Be aware of position of body, feet, hands and fingers whilst performing operation and maintenance tasks.
- Be aware of unplanned roof support movement.  
Eg. DCV/Solenoid failures or  
Roof Support hit by the goaf.
- Lack of communication.

- Fatigue and Human error.

### Question 5

List 3 controls used on Longwall hydraulic equipment?

**A**

**Any 3 of the below**

- Follow Safe Work Procedures and perform JSA's.
- Refer to OEM circuit schematics and diagrams at all times.
- Refer to OEM Safe Work Procedures.
- If in doubt ask your supervisor or OEM representative on-site.
- Correctly identify circuits, components and isolation points.
- Isolate hydraulically and electrically 2 roof supports if working between supports when doing repairs or maintenance.
- Confirm isolation and pressure dissipation.
- Inform others in the area of your intentions.

### 7.2 Pressure and Stored Energies. Page 11

#### Question 1

How is pressure stored or trapped in a LW roof support leg?

**A1...**

Pilot Operated Check Valve, "POCV"

#### Question 2

List 4 cylinders on Austar longwall equipment that have stored or trapped pressure?

**A**

**Any 4 of the below.**

- Roof Support Leg cylinder
- Roof Support Flipper cylinder
- Roof Support Stabilizing cylinder.
- Roof Support Caving cylinder.
- Boot End Levelling cylinder.

### 7.3 Isolation, Dissipation, test for dead and special tools. Page 12 -13

#### Question 1

If unsure about circuit Isolation, what would you do?

## APPENDIX

---

A1 If unsure about circuit isolation, do not proceed with task, qualified person for assistance.

### Question 2

What methods can be used to test for dead?

A1

Test for Dead. Use at least two (2) methods to confirm the circuit has been dissipated.

- You must have observed the fluid bleed/vent through the Device or Valve.
- Inspect a pressure gauge for a zero reading, if connected into the circuit.
- Operate the circuit DCV controls.
- Twist hoses or pressure gauge if possible around the area or component.
- Have a second person confirm circuit is dissipated and dead.

### Question 3

List 3 types of bleed/vent devices?

A

**Any 3 of the below**

- Ball valves and diffusers
- Filter back flush units
- Bleed screws
- Manometers. (DBT)

### Question 4

What is the tool called that is used to bleed/vent Austar roof support Leg cylinders?

A Manometer port Gauge

### Question 5

Where is this bleed/vent device kept at Austar?

A . In the spares draws on the mono rail.

### Question 6

Demonstrate Isolation, Bleed/vent and test for dead, using the 2 circuits on the demonstration board.

### Question 7

Demonstrate pressure dissipation on the circuit board using the Manometer gauge port tool.

### 7.4 Hydraulic Intensification. Page 14 -17

#### Question 1

List 3 Causes of pressure intensification.

- Steel blanking plugs being installed into ports of an overhauled cylinder and the annulus blanking plugs not being removed before powering up the cylinder.
- Incorrect length annulus side hose being pinched off on a cylinder will cause pressure intensification.
- Unplanned movement of the roof support caused by falling goaf, which causes DA Ram to intensify.

#### Question 2

List 3 controls used to prevent pressure intensification at Austar.

**A**

**Any 3 of the below.**

- Installation of plastic blanking plugs on overhauled cylinders.
- Installation of the correct length hose on the annulus side of a cylinder.
- Support brackets for hosing.
- High flow Relief Valves
- Burst Disc

### 7.5 Hydraulic staples. Page 18 -20

#### Question 1

What must you do if replacing hoses or hydraulic fittings?

A. Replace the Staple

#### Question 2

List 4 types of staple failure modes

**A. Any 4 Of the below**

- Staples cracking or breaking
- Physical abuse of staples.
- Corrosion

- Fatigue. Exceeding service life of the staple
  - Overload of staple
  - Mechanical overload from external sources, being hit by debris or excessive bending moment
  - Wear of staple
  - Wrong specification for staple material and dimensions
- Poor quality control of staple manufacturer

### Question 3

List 2 controls used to avoid staple failures.

A

**Any 2 of the below.**

- Staple Audits
- Staple retention devices
- Periodically replace of staples
- Identifying special staples and make tradesman aware of them and keep available spares onsite and underground.

### Question 4

List steps to install staples.

A

- Confirm hose or fitting is installed correctly by inserting single leg of staple into fitting.
- Tap staple into fitting.  
If staple is not going through fitting re assess that the hose or fitting is installed correctly.

### Question 5

List 2 things not to do to staples.

A

**Any 2 of the below**

- Never bend, compress or deform a new staple to fit a fitting.
- Always use the correct staple size for the fitting size.  
Eg. Just bend that 13mm staple to fit that 10mm fitting. **WRONG.**
- Never hang equipment off staples.
- Never use the single legs of two staples in a single fitting.

### Question 6

Indicate incorrect staples on demonstration board.

7.6 Hydraulic Hose. Page 21 -22
---------------------------------

### Question 1

What are the 2 most important pieces of information on hose labelling?

A1 Working Pressure

A2 Approval number

### Question 2

Hoses and fittings are manufacture to a safety factor. What are these safety factors?

A1

- Hoses have a safety factor of 4:1
- Hose fittings have a safety factor of 2.5:1

### Question 3

List 4 things to consider when installing hydraulic hoses.

A

#### **Any 4 of the below**

- Do not exceed working pressure of hose.
- Keep hose Routes neat and tidy, away from sharp edges, areas where stone, coal or mud will build up and surfaces that may causing abrasion
- Secure and support along entire length of hose e.g. zip-tie every 300mm.
- Mechanically protect hose from damage in high wear areas.
- Use the correct length hose for the task
- Do not expose hose to temperatures above hose specification.
- Do not use as a strength member for pulling or lifting.
- Do not exceed bend radius of specified hose

### Question 4

List 4 safety controls used for Hydraulic hose.

A

**Any 4 of the below**

- Hose Whip checks.
- Kevlar sleeves
- Rubber sleeves
- Higher pressure rated hose
- Audits
- Regular replacement of hose in high use and wear areas
- Higher manufacturing standards
- Hose inspection by tradesman
- Recognise application of hose in high pressure
- Recognise high cyclic rates e.g. high pressure set hose.

7.7 Rules and Regulations. Page 23
------------------------------------

### Question 1

List 4 rules to follow when working with hydraulics.

A

- Always wear PPE when working with or around LW hydraulic equipment
- Always follow mine site safe work procedures.
- Refer to OEM manuals for technical and safety issues.
- Never perform a task you are not confident to perform.

### Question 2

What regulations are employers and employees required to follow?

A1 Section 20 of the *Occupational Health and Safety Act 2000*



AUSTAR COAL MINE

TRDOC-038

LONGWALL HYDRAULIC SAFETY  
TRAINING COURSE

Rev	Date of Revision	Revision Description	Reviewed By	Approved By
0	20/03/2012	Added to controlled documents	Longwall Advantage Bill Buman	



**1.0 COMPETENCY TRAINING MAP**

The Competency Training Map below shows how this training course Longwall Hydraulic Safety (Tradesman) fits into the MNCU1076A Conduct Longwall Face Equipment Operations National Competency Standard.

This training course and assessment covers some of the elements MNCU1076A Conduct Longwall Face Equipment Operations. The Competency Training Map shows the elements that are covered.

The assessment from this training course can be used as part of the assessment for MNCU1076A Conduct Longwall Face Equipment Operations.

**2.0 LONGWALL HYDRAULIC TRAINING COURSE SUMMARY**

ELEMENTS	LEARNING SEQUENCE	DESCRIPTION	ASSESSMENT
<b>MNCU1076A/02</b> <u>Operate Longwall Equipment.</u> 2.6 Recognise and respond to hazardous and emergency situations in accordance with manufacturer instruction and/or site procedures.	7.1 Explain the consequences of high pressure injection.	Using photos and accounts of injuries to understand the affects associated with high pressure injection.	The trainee will be asked to complete in their own hand writing, 5 questions on the topic 7.1 Injuries and Dangers associated with high pressure.
	7.1 Explain the site emergency and first aid procedure.	Understand the site emergency and first aid treatment for high pressure injection.	
	7.1 Explain hazards associated with longwall hydraulic equipment and controls set in place to minimise hazards.	Understand the hazards associated with longwall hydraulic equipment and controls set in place to minimise hazards.	
	7.2 Explain the different pressure values used in and around longwall equipment & the hazards associated with stored pressure/energy in hydraulic circuits.	Understand the different pressure values used in and around longwall equipment & the hazards associated with stored pressure/energy in hydraulic circuits.	The trainee will be asked to complete in their own hand writing, 2 questions on the topic 7.2 Pressure and Stored Energies.
<b>MNCU1076A/02</b> <u>Operate Longwall Equipment.</u> 2.2 Carry out pre-start, start-up, shut-down & isolation procedures in accordance with manufacturer instruction and/or site procedure.	7.3 Explain the rule of thumb method for isolation of longwall hydraulic equipment.	Understand the rule of thumb method for isolation of longwall hydraulic equipment.	The trainee will be asked to complete in their own hand writing, 5 questions on the topic 7.3 Isolation, Dissipation, Test for Dead and Special Tools.  The trainee will be asked to demonstrate on 2 different circuits how to Isolate, dissipate and test for Dead using the demonstration board.  The trainee will be asked to demonstrate how to dissipate pressure using a Conflow Adaptor and fitting on the demonstration board.
	7.3 Explain the use of special tools to dissipated pressure from circuits after isolation.	Understand the use of special tools to dissipated pressure from circuits after isolation.	

### 3.0 INTRODUCTION

Until recently high pressure injection, Isolation labelling and pressure dissipation procedures were not common, nor recognised or instilled into the Australian Coal Industry. Due to recent incidents necessary changes are occurring particularly relating to Longwall Hydraulic Equipment.

The simplicity of control of many hydraulic systems tends to belie the sometimes-awesome power and mechanical forces associated with the equipment. One fraction of a second of carelessness by a simple oversight can result in serious injury and sometimes death.

Longwall fluid power has the equivalent injury potential as electricity and demands equal respect.

### 4.0 PURPOSE

This Longwall Hydraulic Safety Training Course has been developed to address some of the issues that are present in the industry.

At the end of the Longwall Hydraulic Safety Training Course the trainee will be able to identify the dangers associated with hydraulic systems used to operate Longwall Equipment and implement controls to minimise the dangers.

### 5.0 DEFINITIONS

Term	Definition
POCV	Pilot Operated Check Valve
DCV	Directional Control Valve
BSL	Beam Stage Loader
AFC	Armoured Face Conveyor
OEM	Original Equipment Manufacturer
MSDS	Material Safety Data Sheet
JSA	Job Safety Analysis

### 6.0 REFERENCES

- MDG41 Draft
- O, H and S
- Site Procedures
- DPI Safety Alerts
- Hydraulic supplier manuals
- OEM Manuals
- Coal Mines Regulation Act
- Workcover

7.1.3 Fatal Injuries



NSW DEPARTMENT OF  
PRIMARY INDUSTRIES

**SAFETY ALERT**

**Contractor fatally injured by  
high-pressure hydraulic equipment**

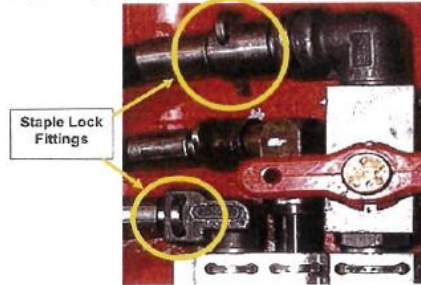
**INCIDENT**

A contractor was fatally injured while taking fluid samples from a large hydraulic system used to power longwall machinery at an underground coal mine.

**CIRCUMSTANCES**

The contractor was at the mine to take fluid (oil) samples from the longwall hydraulic system at various points. The contractor was found adjacent to an open high-pressure hydraulic staple connection. Fatal injuries were consistent with hydraulic injection.

The hydraulic system has a nominal pressure of 305 bar (approx. 4350 psi).



Example of Staple Lock fittings **NOT** related to this incident.

7.1.4 First Aid Treatment For High Pressure Injection

- Gently clean area affected
- Rest patient
- Splint if practical
- Consider ice packs for pain relief
- NIL by mouth
- The person must not be left alone or allowed to drive themselves to the medical facility
- Keep activity of effected area to a minimum

Clearly identify the injected fluid, obtain the MSDS for the injected fluid and send it with the casualty along with information sheet

- Emergency services **DIAL 000**
- Ask for ambulance
- Confirm High Pressure Fluid Injection accident
- and request immediate **Helicopter**
- Evacuation of the casualty



	<b>Austar Coal Mine Longwall Hydraulic Safety Training Course</b>	<b>TRDOC-038</b>
---	---	------------------

<b>Pressure and Stored Energies</b>		<b>1 bar = 14.5 psi</b>
High-set, Posi-set, G-set Emulsion Pump	400 to 440 bar	Pressure
Roof Support Flipper Cylinder	320 to 420 Bar	
Roof Support Leg	320 to 440 bar	Pressure & Stored Energy.
Stabilizer cylinder	320 to 440 bar	Pressure & Stored Energy.
Port-a-power Unit	700 bar	Pressure
Air grease gun	700 bar	Pressure
Shearer Pilgrim Nuts	2275 bar	Pressure

### 7.3 Isolation, Dissipation, Test for Dead and Special tools

#### 7.3.1 Isolation, Dissipation and Test for Dead

Isolate, Dissipate and Test for Dead all LW Hydraulic equipment to the OEM and Mine Site Procedures.

If unsure about circuit isolation, do not proceed with task, qualified person for assistance.

General rules of thumb when Isolating, Dissipating and Testing for Dead are:-

- Refer to OEM circuit diagrams and schematics at all times.
- Identify the correct circuit and isolation Valves.
- Close isolation Valves and Tag/Lock before starting the Task.
- If possible remove primary pressure source. Shut off Pump Station or H/P System Isolators.
- Identify circuit Bleed/Vent Device or Valve.
- Open bleed/vent device or valve to dissipate trapped pressure.
- If bleed/vent Device or valve are not available in the circuit, dissipation of trapped pressure can be carried out at the circuit DCV or use of a special tool maybe required.
- Test for Dead.
- Use at least two (2) methods to confirm the circuit has been dissipated.
- You must have observed the fluid bleed/vent through the Device or Valve.
- Inspect a pressure gauge for a zero reading, if connected into the circuit.
- Operate the circuit DCV controls.
- Twist hoses or pressure gauge if possible around the area or component.
- Have a second person confirm circuit is dissipated and dead.

**WARNING:** If staples are hard to move, re-assess all of the above points before getting a bigger staple lever.

7.4 Hydraulic Intensification

**Areas of major stage of cylinder**

$$= \frac{\pi}{4} \times 240^2$$

$$= 45238.93 \text{ mm}^2$$

**Areas of Annulus**

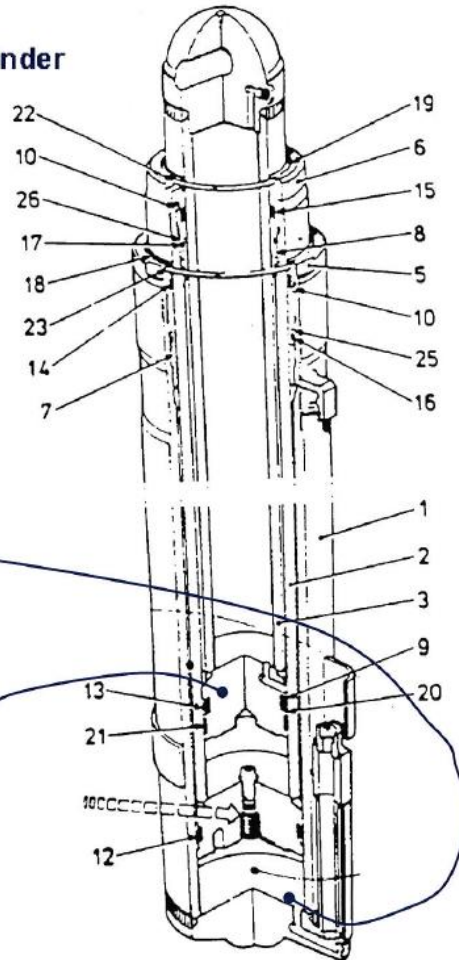
$$= \frac{\pi}{4} (240^2 - 230^2)$$

$$= 3691.37 \text{ mm}^2$$

**Ratio of Areas**

$$= \frac{45238.93}{3691.37}$$

$$= \frac{12.2553}{1}$$



**7.4.3 Pressure Intensification Safety Components:**

**AUSTAR**

Equipment	Type	Pressure Rating
Roof Support Leg (Leg raise)	Pressure Relief Valve	440 bar
(Leg lower)	Burst Disc	520 bar
(Leg lower)	Pressure Relief Valve	520 bar
Stabilizer Cylinder (Both side of Cylinder)	Pressure Relief Valve	440 bar
Flipper cylinders	Yield Valve	420bar
DA Ram Side Shield cylinders Caving cylinders	Pressure Relief Valve	380 bar

The Austar roof support schematic on the next page indicates the position of some of the relief valves

**7.5 Hydraulic Staples**

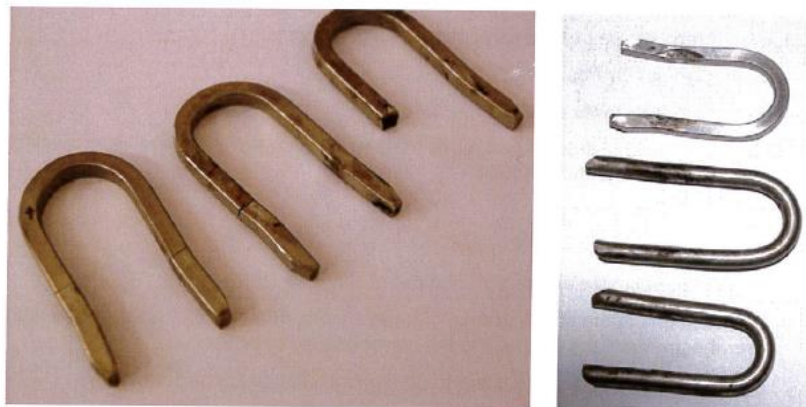
Due to the increase of staple failures and problems occurring in the industry, staples are to be of a one shot use. Eg. If a hose or hydraulic fitting are to be replaced the staples are also.

Staples are manufactured to 4 different standards and the staple standard used depends on the manufacturer.

**Force On Staples**

$$\text{FORMULA} = (\text{Pressure (Mpa)} \times \pi \times (D^2 - d^2 / 4)) / 9.81$$

HOSE DN	“O” Ring OD ØD <sup>2</sup>	Hose ID Ød <sup>2</sup>	STAPLE WEIGHT ON HOSE CAPPED. Kg Force	STAPLE WEIGHT ON HOSE. Kg Force
DN10	14.4mm	7.10mm	581kg Force	440kg Force
DN13	18.6mm	9.6mm	969kg Force	711kg Force
DN20	24.7mm	19mm	1710kg Force	698kg Force



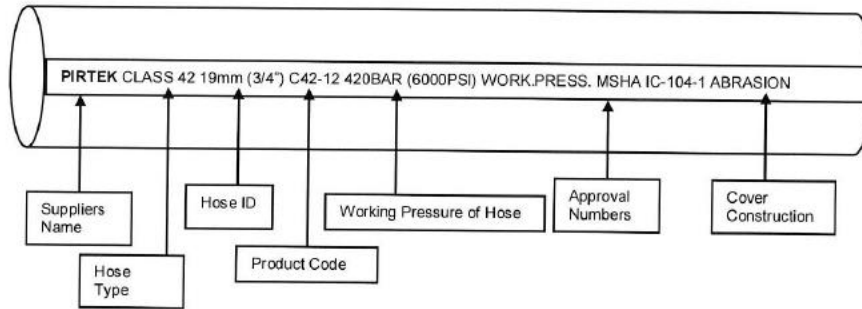
**Staple Failure Modes**

- Staples cracking or breaking
- Physical abuse of staples.
- Corrosion
- Fatigue. Exceeding service life of the staple
- Overload of staple
- Mechanical overload from external sources, being hit by debris or excessive bending moment
- Wear of staple
- Wrong specification for staple material and dimensions
- Poor quality control of staple manufacturer.



**7.6 Hydraulic Hose**

**7.6.1 Hose Identification**



- Cover construction can differ. Eg FRAS = Fire Resistant and Anti Static
- Hose manufacture date will be marked on the hose. If hose date is 5-8yrs old, hose should be proof tested again or discarded.
- The main information to look for on hosing is the working pressure rating, and the approval number.
- Information will vary from hose manufacturers but the working pressure will always remain the same.



**7.6.2 Hose Manufacture**

- Hoses are manufactured to a vast list of standards.
- Hoses have a safety factor of 4:1
- Hose fittings have a safety factor of 2.5:1
- Hose assemblies are proof tested, certified and packaged prior to arrival onsite.

**7.6.3 Hose Installation**

- Do not exceed working pressure of hose.
- Keep hose Routes neat and tidy, away from sharp edges, areas where stone, coal or mud will build up and surfaces that may causing abrasion
- Secure and support along entire length of hose e.g. zip-tie every 300mm.
- Mechanically protect hose from damage in high wear areas.
- Use the correct length hose for the task
- Do not expose hose to temperatures above hose specification.
- Do not use as a strength member for pulling or lifting.
- Do not exceed bend radius of specified hose



To meet your responsibilities under the *OHS Act 2000*, you must provide:

- Safe premises
- Safe machinery and substances
  - Safe systems of work
  - Information, instruction, training and supervision
  - A suitable working environment and facilities.

### **OHS Employees**

Section 20 of the *Occupational Health and Safety Act 2000* states that you must:

- Take reasonable care for the health and safety of your co-workers who may be affected by your actions
- Cooperate with your employer in anything that they do or require, in order to ensure safety.

You must:

- Ensure that your actions do not put others at risk
- Work safely
- Use and maintain machinery and equipment properly
- Ensure that your work area is free of hazards.

Cooperating with your employer may include:

- Notifying your supervisor of actual and potential hazards
- Wearing or using prescribed safety equipment
- Carrying out work in a safe manner
- Following health and safety instructions
- Taking notice of signs
- Adhering to speed limits
- Participating in safety training.

Section 21 of the Act states that you must not intentionally or recklessly interfere with or misuse anything provided in the interests of health, safety and welfare.

You must not:

- Move or deface signs
- Tamper with warning alarms
- Remove machine guards
- Skylark
- Play jokes
- Behave in a way that results in risk to others.

### **MDG41 (Draft)**

MDG41 Guideline "fluid power system safety at mines" will be used to provide a good industry benchmark for engineering standards for fluid power and minimise the risk to the health and safety of personal working on and around these systems.



## AUSTAR COAL MINE

TRDOC-024

### LONGWALL AUTHORISED ISOLATOR

#### Safe Zones, Pinch Point and Isolation

Rev	Date of Revision	Revision Description	Reviewed By
0	01/11/2010	Reviewed and adding into Controlled Documents	Greg Merrick

Page 1 of 26

S:\Controlled Documents\Standards & Procedures\99 Word Docs\TRDOC - Training Documents\TRDOC-024 Longwall Safe Zones, Pinch Point and Isolation.doc

Table of Contents

1.0 TRAINING INFORMATION .....3

1.1 Longwall Services – Pipe Ranges .....3

1.2 Longwall Pump Station C/T .....3

1.3 Monorail .....5

1.4 BSL and Boot-end .....8

1.5 Maingate Drive – Roadway supports, Front AFC and Rear AFC .....9

1.6 Face and Shearer .....10

1.7 Tailgate Front Drive .....13

1.8 Face Operating Sequence and Standing Zones .....13

2.0 CIRCUIT DRAWINGS .....16

3.0 SAFETY ZONES .....21

3.1 Maingate Safety Zones .....22

3.2 Shearer Safety Zones .....24

3.3 Tailgate Safety Zones .....26

## 1.0 TRAINING INFORMATION

A review of the longwall equipment has been conducted to ensure that all Isolation points and Emergency Stops are known and all nip points are identified and controlled.

The Isolation points, Emergency stops and the nip points identified are grouped into localities as follows:

- 1 Longwall services – Pipe Ranges;
- 2 Longwall Pump station C/T;
- 3 Monorail;
- 4 BSL and Boot-end;
- 5 Maingate Drive;
- 6 Face and Shearer;
- 7 Tailgate drive.

The Emergency Stops are a Control Circuit Emergency Stop only and are not to be used for isolation of machinery.

*In all cases if isolation is required the correct Full Current Isolation and Tag/Lockout procedure must be followed.*

### 1.1 Longwall Services – Pipe Ranges

The isolation points for the pipe ranges supplying services to the longwall face are:

#### **Raw Water**

A 4" ball valve isolates the 4" raw water flexible feed line. This line crosses the travel road and tees into the Shearer Water Pump via an isolating valve and also feeds the Monorail.

#### **Compressed Air**

A 2" gate valve isolates the compressed air flexible feed line. This line crosses the travel road and goes through the pump station cut through to the monorail.

#### **Solsenic**

A 2" ball valve is located on the end of the black poly pipe solsenic feed to the pump station.

### 1.2 Longwall Pump Station C/T

#### **Transformer Emergency Stops**

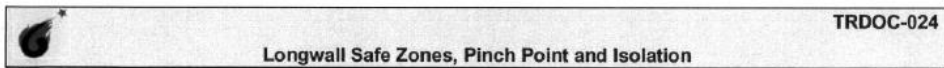
There is an Emergency stop (S1) located on the High Tension end of the Transformer Sled adjacent to the Inbye rib.

Operation of this Emergency Stop Button will cut off the 11kV supply to the transformer at the onboard 11kV Circuit Breaker.

A second Emergency Stop (S6-1) is located on the Low Tension end of the transformer. Operation of this E/S will take the power away from the Longwall DCB.

A third Emergency stop (Tailgate Enclosure Emergency Stop) is located near the PLC screen on the Low-tension end of the transformer. Operation of this E/S will stop the Tailgate Enclosure

A DAC for face and surface communication is located near the PLC screen. This DAC and the DAC's running along the Monorail all have Lock Out Buttons that act as an Emergency Stop for the Pump Station. To start the Pump Station again the Lock Out Button is to be put back into RUN and the RESET on the PLC operated on the Low-tension end of the transformer.



#### **Pump Station Electrical Isolation Point**

On the Low-tension end of the transformer is the Electrical Isolation Point for the Pumps.

Isolation is to be carried out by an Authorised Electrician.

#### **Pump Station Emergency Stops**

There is an emergency stop at each corner of the Hydraulic Pump Station. Operation of the emergency stop will stop the entire pump station. This is a control circuit emergency stop and is not to be used for isolation of the pump station. The individual pumps have remote Stop / Start buttons used when pumps are ran in manual mode.

Access onto the pump station sled requires the pump station to be shutdown and de-pressurized.

#### **Longwall Pump Station Isolation**

The isolation points for the longwall pump station are:

- **Shearer Water Inlet**

A 4" ball valve isolates a flexible 4" line that tees off the pipe running across the pump station cut-through. The water inlet goes through a Strainer filter before entering the pump. There are isolation valves either side of the filter.

- **Fire And Cooling Water**

A 4" tee after the Strainer filter has a manifold attached with 2 x 2" isolation valves feeding the fire & cooling water circuits.

- **Solsenic Fill Line**

Fill line connects to tank via a 2" isolator located near the fill solenoid and filter.

- **Shearer Water Pump Discharge (80 Bar max - 735psi)**

A 2.5" ball valve isolates the high-pressure water supply from the Shearer Water Pump. This feeds into the high pressure shearer water hose that runs across the cut-through to the monorail. The Shearer Water Pump Starts only when The Shearer or Rear AFC is started.

- **High Pressure Emulsion Lines (345 Bar - 5000psi)**

There are two high-pressure emulsion lines from the hydraulic pump station to the monorail. Each of these lines has a 2" isolating ball valve at the pump station discharge manifold.

- **POSI-Set Emulsion Line (420Bar – 6100psi)**

There is a single Posi-Set emulsion line running from the pump sled to the monorail. This line has a 1.5" isolator mounted on the discharge manifold.

- **Emulsion Return Lines (70 Bar – 1000psi)**

There are two emulsion return lines to the hydraulic tank from the face. There is an additional emulsion return line from the depressurisation valve. There are no isolation valves in any return lines to the Pump station. Isolation for the Return must be done at the Pump Station Emulsion Delivery Isolation valves or the Emulsion Isolation valves at one of the Filter Stations.

**Colour Coding of Hoses**

The hoses feeding into the monorail system are colour coded at each hose coupling as follows;

High Pressure Emulsion	Red
HIGH PRESSURE SET- Posi Set	RED-YELLOW STRIPE
Emulsion Return	Orange
Fire Line	Green-Red Stripe
Cooling	Green- Blue Stripe
High Pressure Shearer Water	Yellow
Compressed Air	Blue

Charts showing colour coding are available at the Filter Sleds and Mule Drives along the Monorail.

1.3 Monorail

**Outbye Monorail Filter Sled**

The following isolation points are located on the Outbye Monorail Filter Sled.

- Two (2) High Pressure Emulsion Feed Lines

A 2" ball valve isolates the feed line at the connection point into the monorail filter sled this is on the outbye side of the filter. A second ball valve isolates the line on the inbye side of the filter. Vent ports are located on the outbye side of the filter housing. These ports are comprised of a 10mm ball valve and diffuser.

- Two (2) Emulsion Return Lines - bypass this sled - (no isolation points)
- Compressed Air

A 2" ball valve isolates the feed line to the monorail and face. This ball valve is located at the connection point to the filter sled. The compressed air supply can be vented using the outlets along the monorail.

- Fire Water

A 2" ball valve isolates the feed line at the connection point into the monorail filter sled. A second ball valve is fitted after the filter. A vent port to dissipate pressure is located on the outlet side of this filter. The vent port comprises a 10mm ball valve connected to a diffuser.

- Cooling Water

A 2" ball valve isolates the feed line at the connection point into the monorail filter sled. A second ball valve is fitted after the filter. A vent port to dissipate pressure is located on the filter-housing top. The Vent port comprises a 10mm ball valve connected to a diffuser.

- High Pressure Shearer Water

A 2.5" ball valve isolates the feed line at the connection point into the monorail filter sled on the outbye side of the filter. A second ball valve isolates the line on the inbye side of the filter. A vent port is located on the outlet side of the filter. This port is fitted with a 10mm ball valve and diffuser.



- **Posi-Set Pressure Emulsion Feed Line**

A 1.5" ball valve isolates the feed line at the connection point into the monorail filter sled on the outbye side of the filter. A second ball valve isolates the line on the inbye side of the filter. A vent port is located on the filter bowl. This port comprises a short hose, 10mm ball valve and diffuser.

- **Decompression Circuit**

A Decompression Valve is fitted to the inbye end of the sled. This valve works in conjunction with the dump system lowering the stored pressure in the monorail hoses to 100 bar when the face is dumped. The decompression circuit works on the high pressure emulsion and posi-set emulsion pressure circuits only. Isolators are fitted to the inbye end of this valve. Posi-set and Main Feed Pressure can be observed on the gauges fitted above the valve.

#### **Monorail Drive Mule**

All Monorail Drive Mules are isolated with a 25mm ball valve on the compressed air line feeding the drive. This valve is located where the feed line tees off the 50mm compressed air line running through the Monorail system. There are 7 monorail break points. All odd numbered break points have an air driven drive unit installed, plus a DAC and monorail lighting isolator. All even numbered break points provide a connection point only for services and DAC communications. It may be necessary to isolate more than 1 drive mule before starting your task.

#### **Longwall Panel Conveyor Signal Line Switches**

Alongside the Monorail system, the panel conveyor pullwire switches run at intervals of 100m. The belt can be stopped anywhere along this length by pulling the lanyard away from the structure.

This lanyard system is a control circuit only and does not provide full current isolation; these switches must not be used for belt access, repair or maintenance.

Be aware that nip and crush points exist along the length of the belt.

#### **Fire Hydrant**

Located between the tool boxes on the Monorail is the Fire Hydrant. All fire fighting equipment for the hydrant is located in the Fire Depot near the DCB.

#### **Inbye Monorail Filter Sled**

The following isolation points are located on the Inbye Monorail Filter Sled.

- **Two (2) High Pressure Emulsion Feed Lines**

Each high pressure feed line delivers into a separate filter on the inbye filter sled. A 2" ball valve isolates each feed line on the outbye side of the filter. A second ball valve isolates each line on the inbye side of the filter. Vent ports consisting of a 10mm ball valve and diffuser are located at the base of the filter housing.

- **Emulsion Return Line**

Emulsion return lines are the two stainless steel pipes in the top of the Filter Sled. There are no isolation points in the emulsion return line at this sled.

- **Posi-Set Emulsion Line**

The posi-set emulsion pressure feed line connects to a filter via an isolation valve. After the filter a second isolator is installed. Venting of this filter is via operation of the back-flush handles.

- **Compressed Air – Runs over the top of the Filter Sled**

- Fire Water

A 2" ball valve isolates the feed line at the outbye & inbye end of the filter. Pressure is vented or released using the "back-flush" handles located on the top of the filter assembly.

- Cooling Water

A 2" ball valve isolates the feed line at the outbye & inbye end of the filter. Pressure is vented or released using the "back-flush" handles located on the top of the filter assembly.

- High Pressure Shearer Water

The high-pressure water circuit feeds 2 back-flush filters. Each filter has an isolator valve before and after the filter assembly. To vent filter assembly operate back-flush handles.

**Pressure Differential Gauges**

Located on the Inbye end of the Inbye Filter Station are the filter Pressure Differential Gauges.

These Pressure Differential Gauges are used to monitor the condition of the filters and DO NOT show system pressure.

**Dump Valve Sled**

The face high-pressure hydraulics, both main pressure and posi-set pressure are controlled by the dump valve located on this sled. Operation of the Emergency Stops at the Inbye Filter Station, Bootend and PMC-R Emergency Stop buttons will cause the dump valve to operate, taking the face hydraulic supply to return. The dump valve does not provide hydraulic isolation. Resetting of the Emergency Stop buttons will allow the hydraulic feed back onto the face.

The various services to the face can be monitored on this sled with the use of pressure gauges.

**DCB Emergency Stop**

The DCB is fitted with an Emergency Stop button, located on the outbye end of the DCB. Operation of this button will open the DCB pilot circuit controlling the 3.3kV supply cables from the pump station transformer to the DCB. This will remove all 3.3kV power from the DCB, monorail and face.

**DCB Electrical Isolation Point**

On the Inbye end of the DCB is the Electrical Isolation Point for all Face equipment. Isolation is to be carried out by an Authorised Electrician.

**Maingate Belt Full Current Isolation Switch**

The Longwall Panel Conveyor has been installed with a remote full current isolation system. This system allows the conveyor to be fully isolated from a single switch. Power is then restored with motorised circuit breakers at the conveyor starter.

To operate the remote full current isolation system you must be trained and authorised to use.

If the remote full current isolation system is not working correctly, full current isolation at the drivehead as required.



**DAC Communication System and Telephones (Pump Station & Monorail)**

The Telephones are located at the outbye end of the DCB and Roof Support #4

Telephone numbers in the Longwall Panel now are:

Longwall Drive/Head	580
Longwall Face	584
Longwall Transformer/Pumps	581
Longwall/Crib Room	582
Tailgate/Bleeder Road	585
Maingate Drive/DCB	583

Consult the Telephone Directory Listing for changes in the phone numbers.

The DAC Communication System extends from Pump Station Transformer, along the monorail, to the tailgate via the roof supports.

The DAC system is also connected to the Surface Control Room.

1.4 BSL and Boot-end

**Removing belt structure**

Notify control room and the face of the intended stopping of the belt to remove structure. This task is normally done through coordination with the section Deputy and face operators. Consideration should be given to the amount of coal on the belt. Allow the belt to run empty for minimum 10 minutes to allow the coal to clear.

Stop and isolate the belt at the boot end using remote isolation. Wait for verification that the isolation was successful.

Remove belt structure as per SWP for task.

If the belt is being used to run structure and mono-rail outbye to pod or cassette, sentries are to be posted at cut through entrances to prevent persons travelling the walkway alongside the belt while structure is being conveyed.

An accurate count must be carried out of the structure to ensure no parts are left on the belt.

Prior to running the structure verbal communication via DAC must be sought from the sentries that they are in place.

**BSL and Boot-End Controls**

The Boot-end is advanced and aligned using the hydraulic control levers adjacent to the discharge end of the boot. A cover is over the Bootend control levers and the support brackets must be installed to stop cover from falling.

The "Push-Accept" and "Emergency Dump or Stop" controls are located adjacent to the boot-end control valve bank. Operating the Dump Button will dump the High Pressure and posi-set supplies to return. Release of this button will return the supplies to the face.

The "push accept" button must only be pushed when it has been determined that no person is working or travelling in the area from the bootend to the sky walk.

A verbal warning is to be broadcast over the DAC to warn people of the intended movement of the BSL.

The nip points identified at the snubber rollers require the webbing strap or mesh to be in position and tightened after advancing the boot.

The bridge across the discharge end of the Boot allows access to the Off-Walkside of the belt and boot only when the following conditions are met:

- Panel Conveyor Belt isolated using remote isolation with voice confirmation or full current isolation;
- BSL stopped;
- Ribs and roof checked and barred down if necessary;
- Deputy advised.

#### **DAC Control Box**

DAC Control Box is located inbye of the boot control station. This DAC will stop the BSL and AFC chains. A DAC is located on the outbye side of the Boot-end controls; this will stop the BELT, BSL and AFC in normal operating conditions.

#### **Beam Stage Loader – Circuit Isolators**

The BSL has 4 separate hydraulic circuits, fed from one location at the BSL manifold.

##### 1 Boot End Control.

Isolated at a ball valve located on the BSL structure above the belt tail roller assembly. For venting of this circuit and the "Over push" circuit consult the DBT manual.

##### 2 BSL Chain Constant Tensioner.

Isolated at the ball valve mounted on the BSL structure above the belt tail roller assembly.

##### 3 BSL Chain Slow Runner.

Isolated at the ball valve mounted on the BSL structure above the belt tail roller assembly.

##### 4 Plow and mono-rail removal platform

Isolated at the ball valve mounted on the BSL structure above the belt tail roller assembly.

#### **BSL Manifold**

All services are connected thru a manifold area located outbye the crusher drive gearbox no services can be isolated here except the compressed air to the faceline.

#### **BSL Air Manifold**

Before the Face Air Isolator is a Tee and Isolation Valve. Be aware this connection is used when a Pump Station and Services move are under taken to allow the air to be reversed to power the Air Mule drives.

#### **Walking over the mono-rail platform**

This platform is in place to assist with mono-rail removal. It must be kept clean and tidy

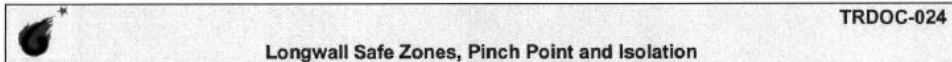
##### 1.5 Maingate Drive – Roadway supports, Front AFC and Rear AFC

The Maingate area is accessed by travelling alongside the BSL. Nip or crush points exist alongside the crusher and roadway supports. inspect ribs alongside crusher and roadway supports and bar down if necessary before passing through.

When accessing the face, if the longwall creep has reduced the walkway giving reduced clearance, caution must be taken and the correct access procedure followed.

The top of the maingate drive, crusher or cable trays are not to be accessed whilst the BSL, Crusher or AFC are running.

If access is required to the top of the Maingate Drive or above the CME Enclosure underneath the Maingate Roof Supports, then the relevant roof supports must be isolated and tagged.



When Gate Supports are being advance always move to an Operating Zone as nip and crush points exist.

#### **Maingate CME Emergency Stop**

The CME is fitted with an Emergency stop; operation of this button will drop power to the CME at the DCB. This will stop all control circuit power on the face and as a result, stop all 3.3kV motor supply from the DCB. The button is located on the top L/H corner of the CME Enclosure.

This will not stop the hydraulic pumps.

#### **Main Gate AFC and BSL Control**

The Front and Rear AFC's can be stopped by operating the DAC Controls located every 6 supports across the face.

The selection of Front and Rear AFC chains running is made at the CME.

#### **Maingate PMC-R Control**

The PMC-R Control System has a red Emergency Stop button located on each SCU mounted to each roof support. The SCU also has a black LOCAL stop button.

Operation of any of the emergency stop buttons will de-energise the Dump Valve and cause the face hydraulic pressure to be dumped directly to the return line at the Dump Valve. Solenoid power to the face is also removed.

On each Roof Support there is a Hydraulic and High/Posi Set Isolator, which is normally open, when closed; these valves isolate the pressure feed to a single support only, allowing all other supports to operate. To vent pressure consult the DBT Maintenance Manual.

#### **Maingate Area Hydraulic Isolation**

The main pressures feed to the face connect to No1 support at the Maingate and to the last support in the Tailgate, the interchock hoses complete a ringmain circuit. The main isolation point for the emulsion pressure lines and the other service lines are located at the Inbye Filter Station.

If maintenance is to be performed on the face or ring main hoses, operate the PMC-R control system Emergency Stop first to dump the face pressure, then close both of the high-pressure emulsion feed and the single posi-set isolators at the Inbye Filter Station. Tag/Lockout as per procedure.

The roadway supports can be individually isolated via a ball valve located on each leg or on top of the BSL between the roadway shields.

### 1.6 Face and Shearer

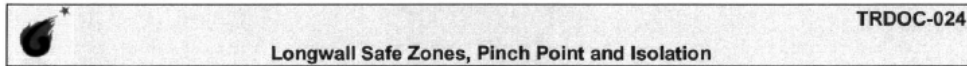
#### **Roof Support Walkways**

The primary walkway is in front of the support along the toes of the base, permitting travel across the face.

A secondary walkway exists between the legs of the supports to access the rear conveyor. As this is a No Go Zone the correct procedure to access this area must be followed.

The face can be safely traversed applying the following procedure:

- When walking in the opposite direction to the support advance direction eg. Travelling to the TAILGATE and the supports are advancing from the TAILGATE:
  - Approach the support advance area and operate the No.8 button (umbrella) and then "enter"
  - The PMC-R display will show "TZONE".



- The leds on the last SCU in the "Travel Zone Range" will be flashing

- When walking in the same direction as the support advance direction eg. Travelling to the TAILGATE and the supports are advancing from the MAINGATE a different procedure is adopted using the "Travel Zone" feature of the PMC-R, as follows.
  - Approach the support advance area and operate the No.8 button (umbrella) and then "enter"
  - The PMC-R display will show "TZONE".
  - The leds on the last SCU in the "Travel Zone Range" will be flashing

When shields are operating in SRB. Communicate with shearer drivers to stop shearer haul. This will stop any more shields advancing.

Consult the SBT Manual for further functionality of the TZONE feature.

**Caution:** *Never attempt to step onto or off a moving support.*

*If more than one person is travelling the face, communicate with each other to ensure the travel zone feature is not defeated with multiple button operations.*

*The travel zone feature does not isolate the Roof Support. Full Current Isolation and Tagging is to be used as required.*

When travelling the face be aware of:

- Lowered supports or canopies at odd angles, these present a collision hazard and also allows loose coal to spill into the walkway creating a slip hazard;
- The Shearer Cable Bretby. As the Bretby travels in the cable trough it creates a nip or crush point along the full length of the AFC between the Shearer Cable Bretby and AFC spill plate handrail.
- If access to this area is required for cleaning or removing coal from the Bretby area then it is important to:
  - Advise shearer operator to stop hauling;
  - Isolate the Roof Supports in this area.
- Placing your feet near the base lift cylinder, under the relay bar, between the relay bar and roof support tunnel and near the rear AFC Advance Cylinder. These cylinders can move and create pinch points.

**Roof supports - Hydraulic Isolation**

On each roof support a main high-pressure emulsion isolator and Posi-set emulsion pressure isolator is fitted. For correct procedures regarding venting consult the DBT manual.

**Shearer Emergency Stop**

The shearer has two (2) different types of stop operations. A lanyard runs the length of the main body of the shearer, pulling the lanyard outward (away from the face) will remove power from the machine. A Motor stop button is located on the electrical panel; depress that button to stop the electrical motor. The hand held remote control also has a remote stop facility.

Access to the shearer is via the front walkway of the supports. Nip points exist between the shearer and AFC spill plate and the cable Bretby and cable tray; ensure that the shearer operator is aware of your intentions before approaching a moving shearer. If close inspection or access to the shearer is required, the shearer haulage is to be stopped. To access the shearer from the front walkway the correct roof support isolation is required. To access the top of the shearer isolate the individual roof supports above the machine.



### 1.7 Tailgate Front Drive

The Tailgate area is accessed by travelling across the Face. Nip, slip and crush points exist across the Face.

When Gate Supports are being advance always move to an Operating Zone as nip and crush points exist.

#### **Tailgate Hydraulic Isolation**

The high-pressure emulsion feed to the face at the Tailgate can only be isolated at the Inbye Filter Station. If maintenance is to be performed on the interchock face or ring main hoses, operate the PMC-R Emergency Stop first, then close both emulsion feed and the single post-set isolators at the Inbye Filter Station and Vent Line as per the correct procedure.

#### **Tailgate Hydraulic Services**

A PTO 10mm ball valve for rea slow runner and tensioner is located in 128 shield next to main isolation valve.

A PTO for the front slow runner and tensioner is located in front of 127 shield on the pan line.

#### **Access to Tailgate Drive**

If access is required to the top of the T/G drive the roof supports in that area over the drive must be isolated.

### 1.8 Face Operating Sequence and Standing Zones

#### **Cutting from Maingate Buttock to Tailgate**

Tailgate shearer operator is to stand on the pontoons 1 to 2 shields tailgate side of Tailgate cutter drum.

Shield operator is to be standing maingate side of advancing shields. If operating in SRB he is to act as a spotter, watching the advancing shield, the shearer operation and shearer drivers.

Any person on the return side of the shearer must stop shearer and shield operation to pass to maingate side of shearer or access rear walkway of Tailgate 4 leg shields for safe zone and wait for shearer and shield operation to leave the area.

Maingate shearer operator is to stand on the pontoons 1 to 2 shields maingate side of maingate cutter drum

#### **Cutting Tailgate to Butt**

Maingate shearer operator is to stand on the pontoons 1 to 2 shields maingate side of maingate cutter drum

Shield operator is to be standing maingate side of maingate shearer operator.

Tailgate shearer operator is to be standing on pontoons 1 to 2 shields Tailgate side of tailgate drum.

All other persons on the face must be Maingate side of maingate shearer operator or Tailgate side of tailgate shearer driver

#### **Cutting Tailgate Butt to Tailgate**

Tailgate shearer operator is to stand on the pontoons 1 to 2 shields tailgate side of Tailgate cutter drum.

Shield operator is to be standing maingate side of advancing shields. If operating in SRB he is to act as a spotter, watching the advancing shield, the shearer operation and shearer drivers.

Any person on the return side of the shearer must stop shearer and shield operation to pass to maingate side of shearer or access rear walkway of Tailgate 4 leg shields for safe zone and wait for shearer and shield operation to leave the area.

#### **Cutting Tailgate to Maingate 23 Shield**

Maingate shearer operator is to stand on the pontoons 1 to 2 shields Maingate side of Maingate cutter drum

Shield operator is to be standing Tailgate side of advancing shields. If operating in SRB he is to act as a spotter, watching the advancing shield, the shearer operation and shearer drivers.

Tailgate shearer operator is to be standing on pontoons 1 to 2 shields Tailgate side of tailgate drum.

All other persons on the face must be Maingate side of maingate shearer operator or Tailgate side of tailgate shearer driver.

#### **Cutting Maingate 23 Shield to Maingate**

Maingate shearer operator is to stand 2 shields Maingate side of Maingate cutter drum as the shearer approaches to maingate corners the shearer operator is to stand on the big foot platform.

Shield operator is to be standing Tailgate side of advancing shields. If operating in SRB he is to act as a spotter, watching the advancing shield, the shearer operation and shearer drivers.

Tailgate shearer operator is to be standing 2 shields Tailgate side of tailgate drum.

All other persons are to be on the sky walk or tailgate side of tailgate shearer operator.

#### **Cutting Maingate to Maingate Butt**

Tailgate shearer operator is to stand on the pontoons 1 to 2 shields tailgate side of Tailgate cutter drum.

Shield operator is to be tailgate side of tailgate shearer driver and caving rear.

Any person on the return side of the shearer must stop shearer and shield operation to pass to maingate side of shearer

Maingate shearer operator is to stand on the pontoons 1 to 2 shields maingate side of maingate cutter drum. On the big foot platform if the shearer is fully in the gate.

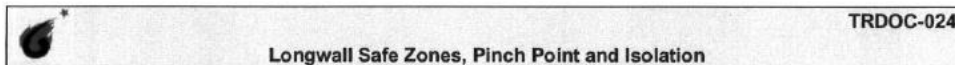
#### **Cutting Maingate Butt to Maingate**

Maingate shearer operator is to stand 2 shields Maingate side of Maingate cutter drum as the shearer approaches to maingate corners the shearer operator is to stand on the big foot platform.

Shield operator is to be standing Tailgate side of advancing shields. If operating in SRB he is to act as a spotter, watching the advancing shield, the shearer operation and shearer drivers.

Tailgate shearer operator is to be standing 2 shields Tailgate side of tailgate drum.

All other persons are to be on the sky walk or tailgate side of tailgate shearer operator.



**Cutting Maingate to Maingate Buttock**

Tailgate shearer operator is to stand on the pontoons 1 to 2 shields tailgate side of Tailgate cutter drum.

Shield operator is to be tailgate side of tailgate shearer driver and caving rear.

Any person on the return side of the shearer must stop shearer and shield operation to pass to maingate side of shearer

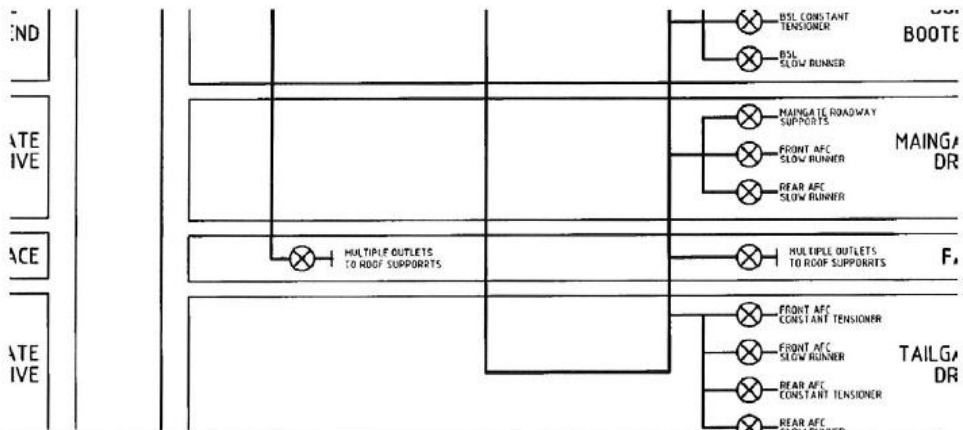
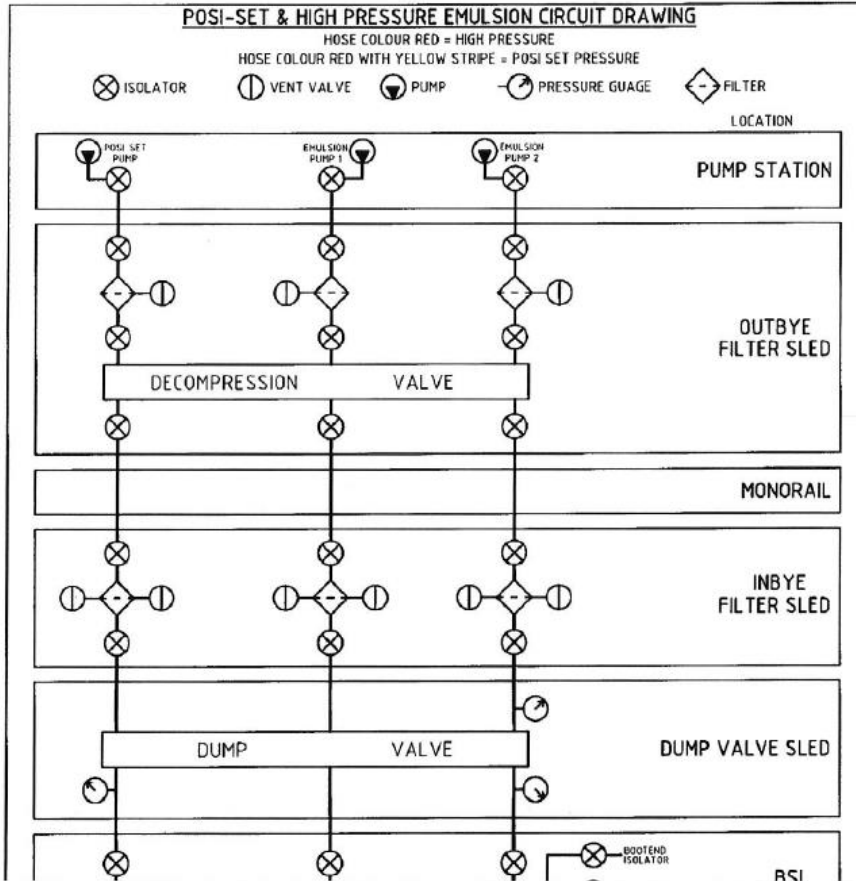
Maingate shearer operator is to stand on the pontoons 1 to 2 shields maingate side of maingate cutter drum. On the big foot platform if the shearer is fully in the gate.

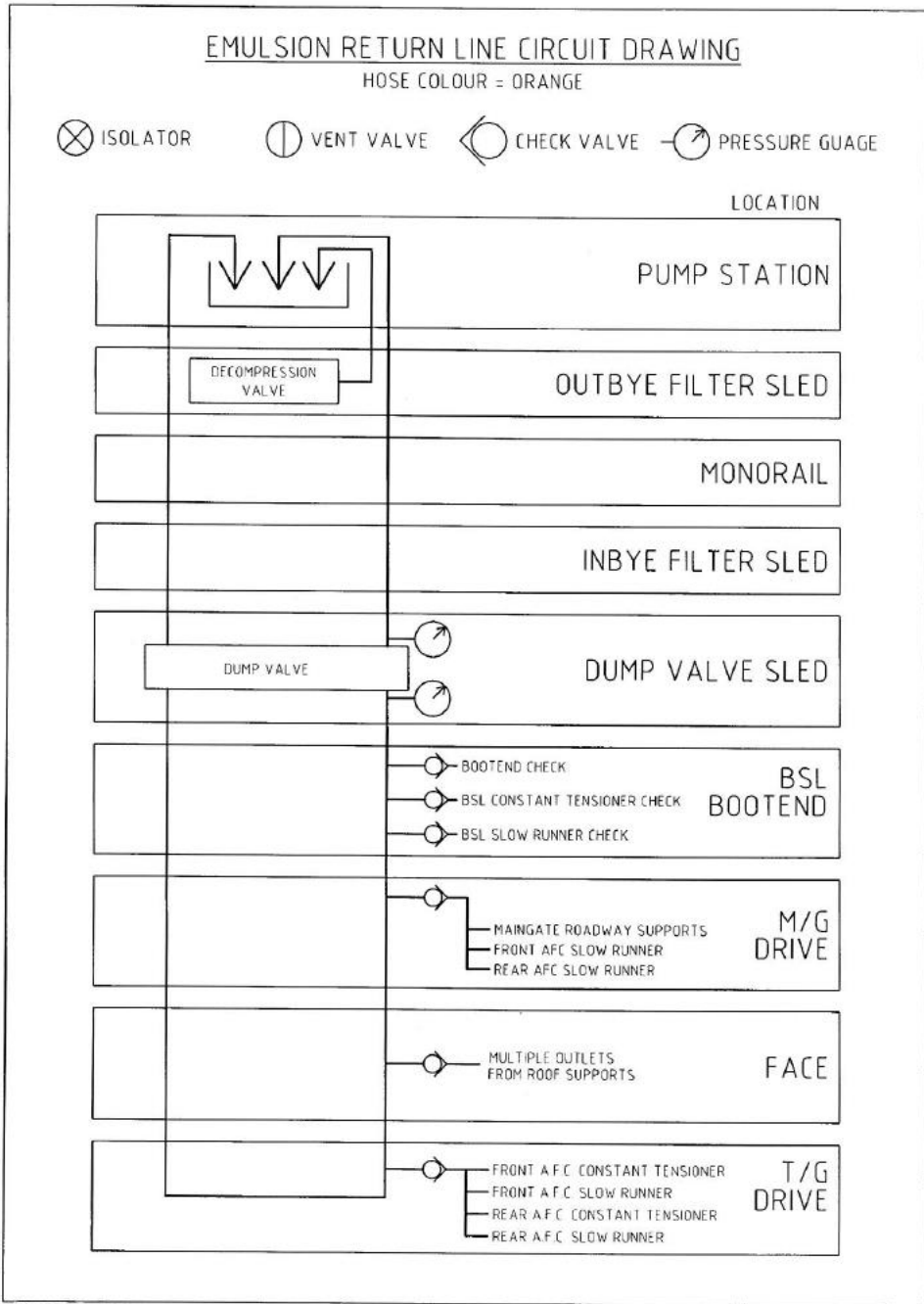
**When Advancing 6 Leg Gate Shields**

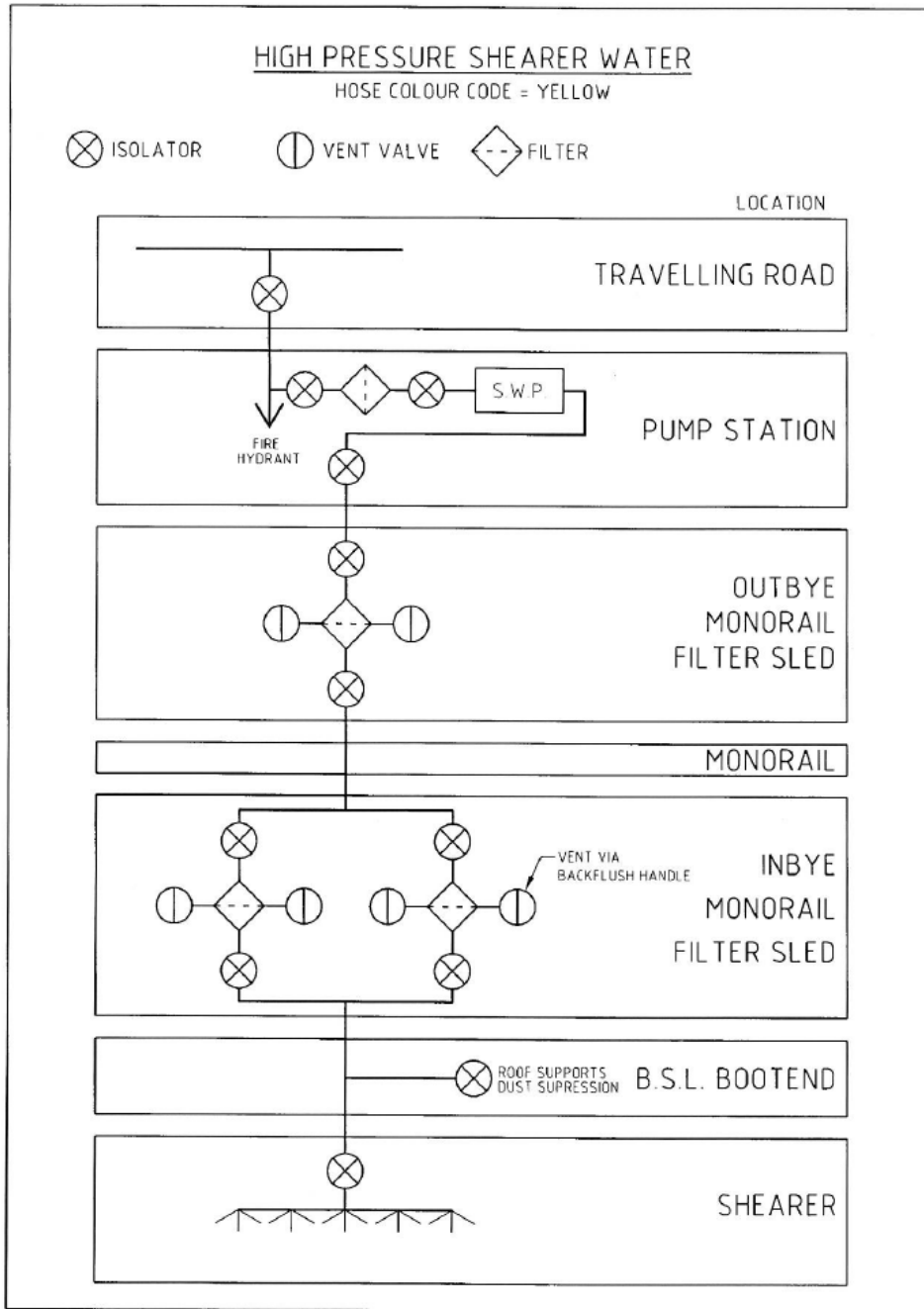
All persons are to be outbye big foot platform or tailgate side of shearer



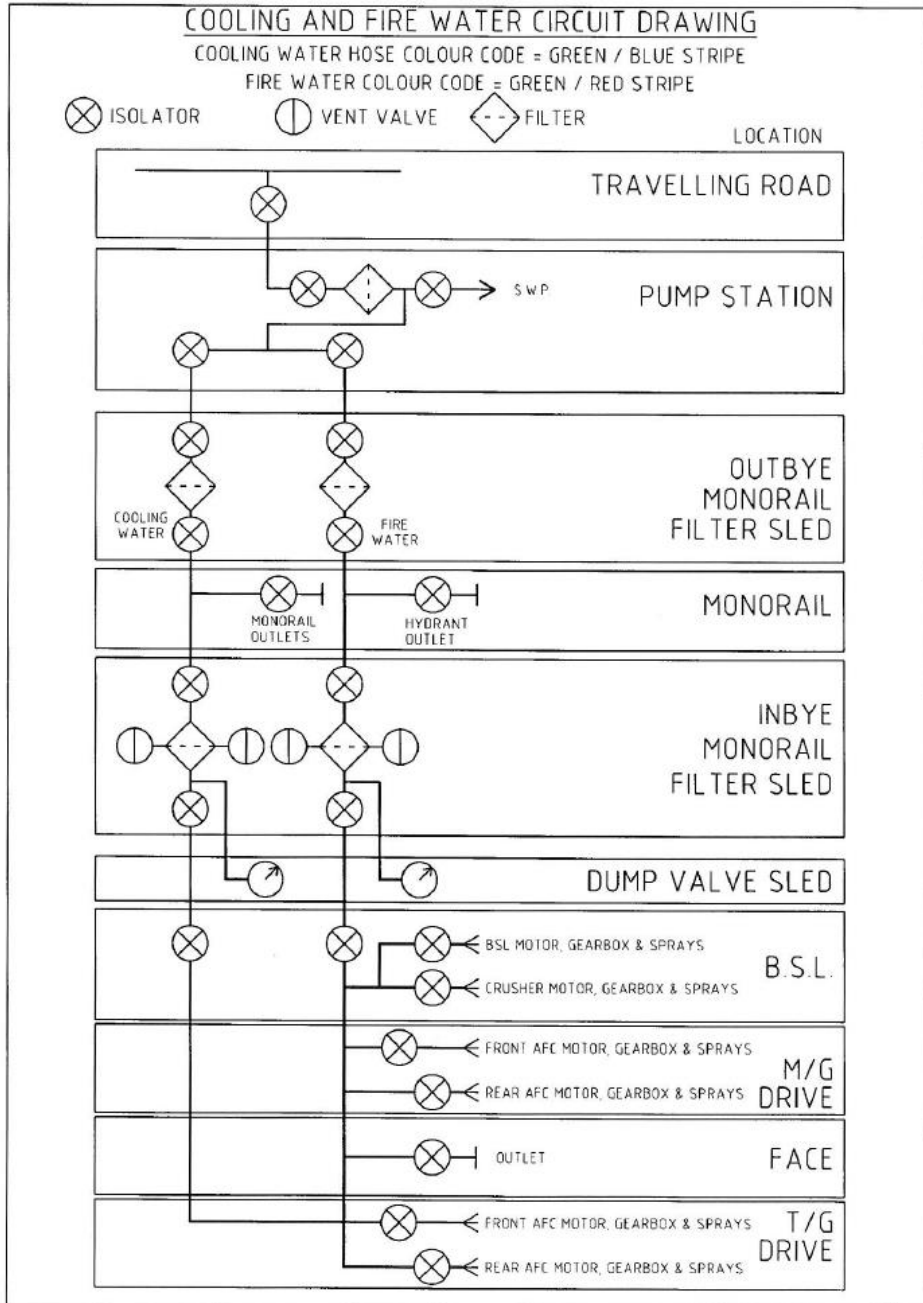
2.0 CIRCUIT DRAWINGS



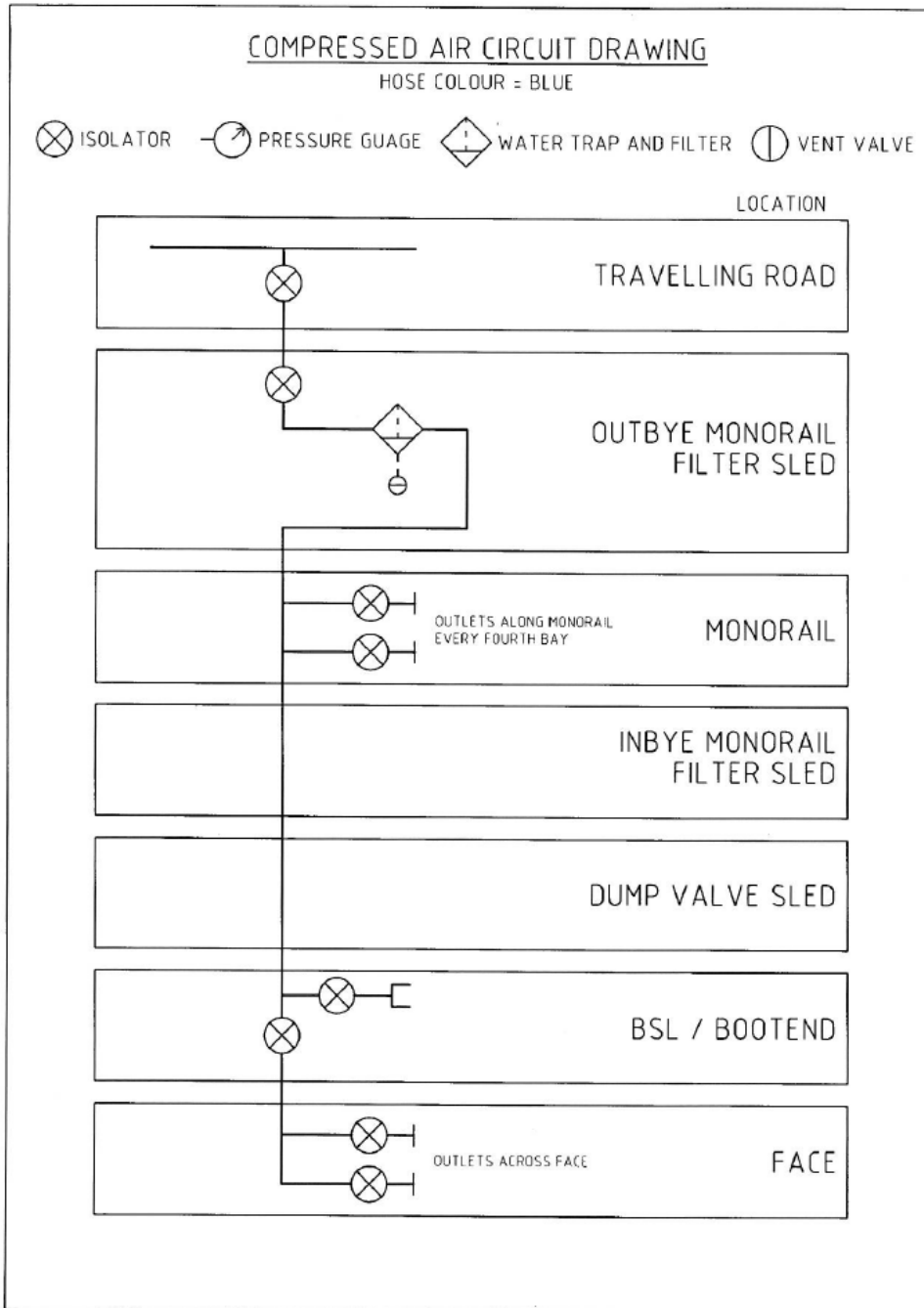




\\LA Drg\922-3100-05-01 AUSTAR LONGWALL SERVICES DIAGRAMS.dwg

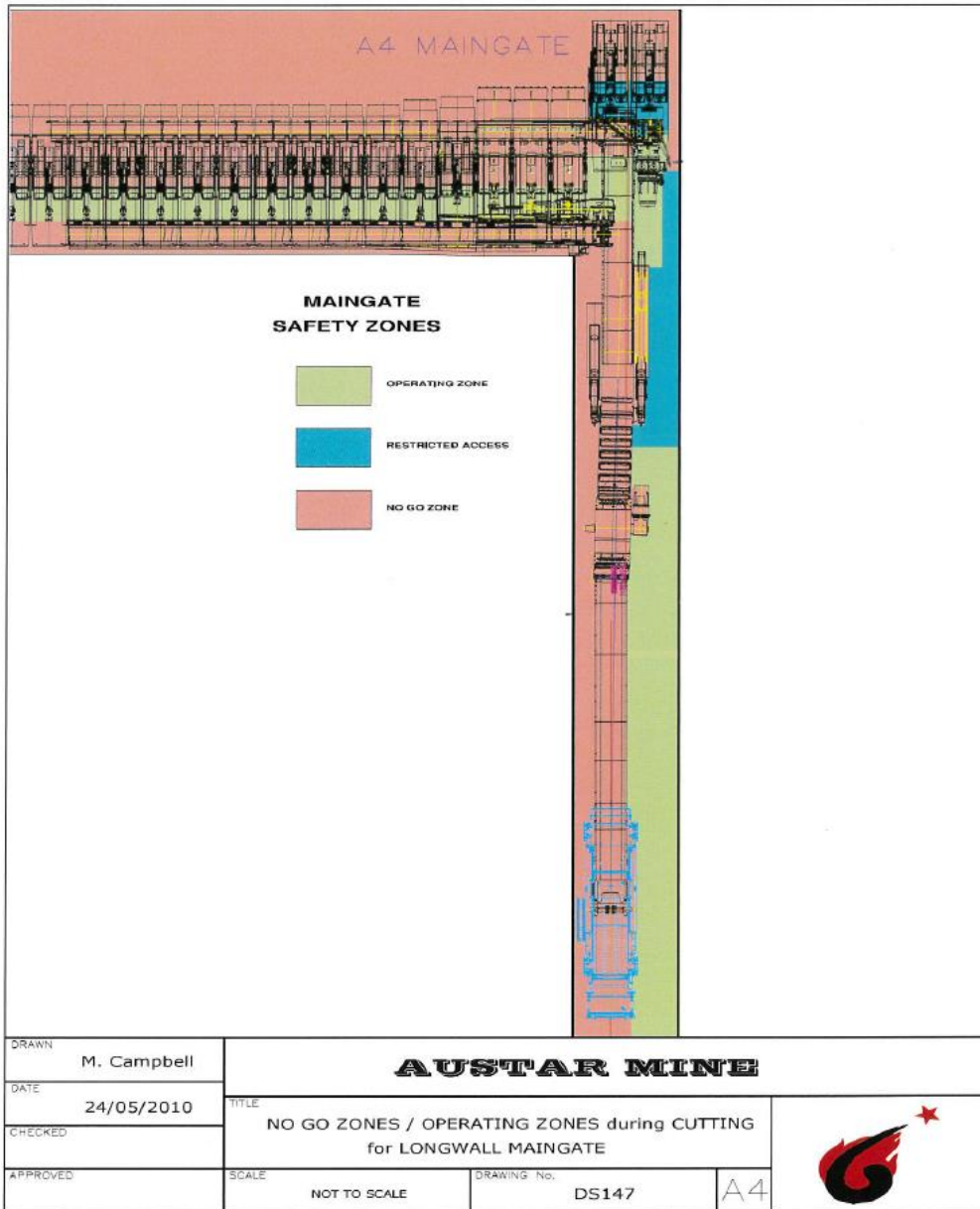


J:\A Dwg\224100-05-01\AUSTAR LONGWALL SERVICES DIAGRAMS.rwg



\\LA Eng 922 0100 05-01 AUSTARLONGWALL SERVICES DIAGRAMS.dwg

3.0 SAFETY ZONES





3.1 Maingate Safety Zones

ENTRY TO SAFETY ZONES

**OPERATING ZONE**

Operating Zones can be accessed in normal operation at all times.

**RESTRICTED ACCESS**

Entering the Restricted Access Zone along the BSL.

1. Communicate with the Bootend Operator or use the DAC to speak to the Maingate Operator to confirm that:
  - o Maingate is not about to be PUSHED
  - o Roadway Shields are not being ADVANCED.
  - o Shearer not entering Maingate area.

If any of these tasks are being performed you will wait in the OPERATING ZONE until advised to pass.

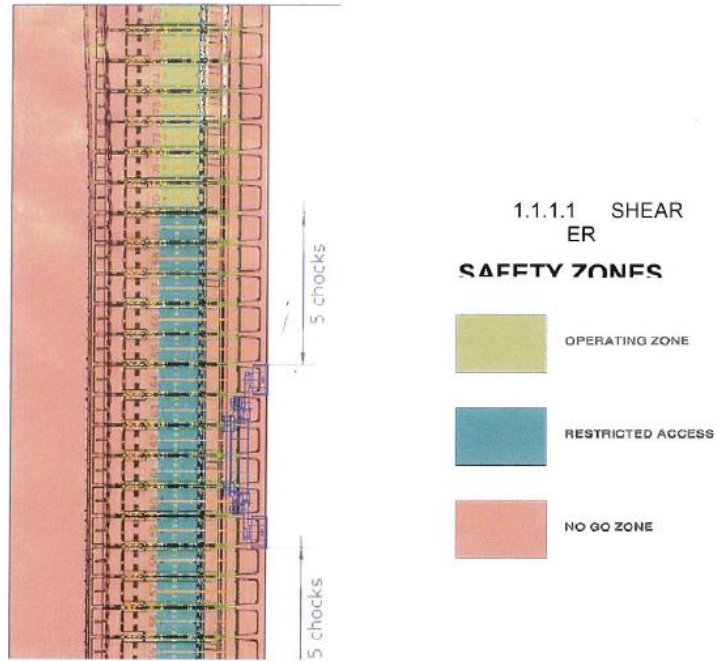
Entering the Restricted Access Zone behind the Gate Shields.

1. Communicate with the Deputy to confirm that:
  - o The area has been inspected and safe to enter.
  - o You are entering the Restricted Access Zone.
2. Isolation:
  - o Isolate and Tag/Lock the Gate Roof Supports that you are working behind and under before entering Restricted Access Zone.

**NO GO ZONE**

Entering a No Go Zone.

1. Communicate with the Deputy to confirm that:
  - o The area has been inspected and safe to enter.
2. Isolation:
  - o Isolate and Tag/Lock all equipment to be worked on and Roof Supports that you are working behind and under before.
3. Follow:
  - o All Safe Work Procedures and perform JSA's
  - o Support Rules.







## 3.2 Shearer Safety Zones

### ENTRY TO SAFETY ZONES

#### **OPERATING ZONE**

Operating Zones can be accessed in normal operation at all times.

#### **RESTRICTED ACCESS**

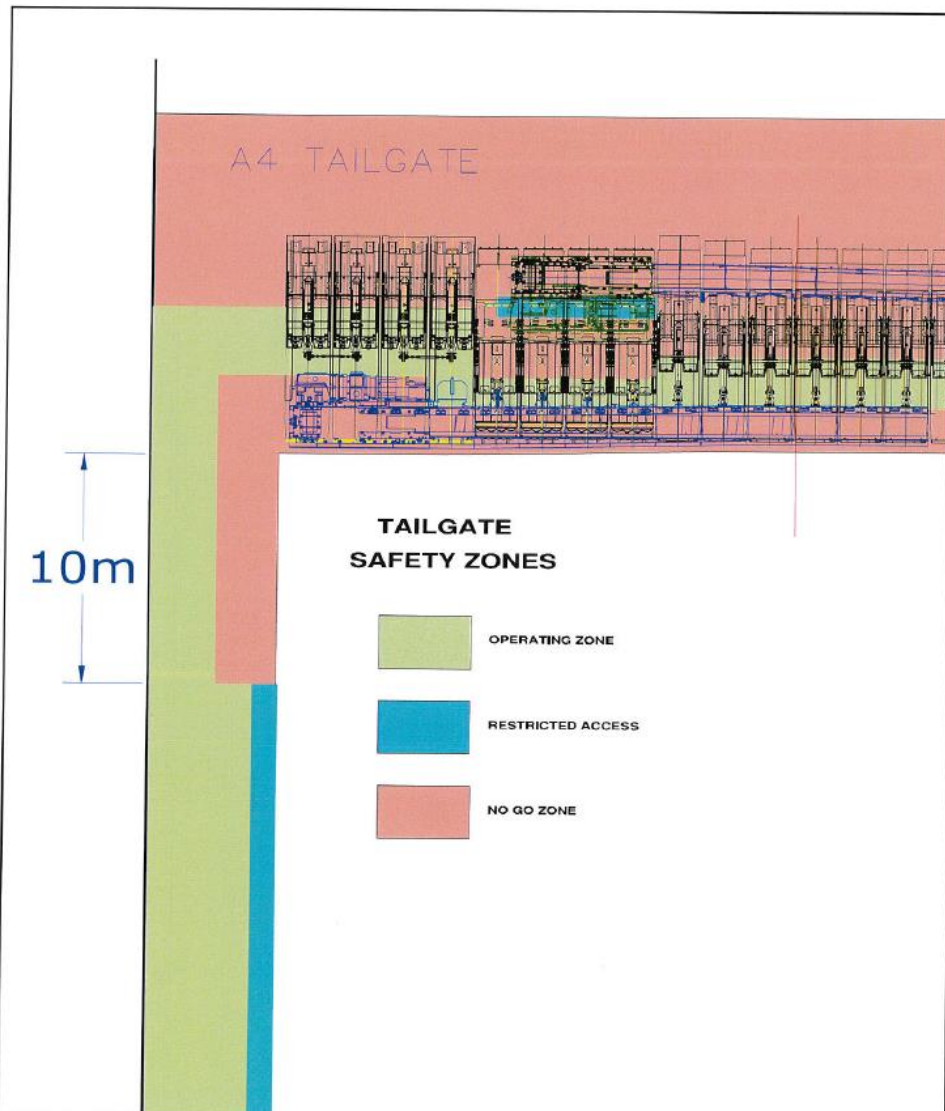
Entering the Restricted Access Zone around the Shearer.


1. Communicate with the Shearer Operator to confirm:
  - o Your intension to pass or carry out inspections
2. Communicate with the Deputy to confirm that:
  - o You are carrying out inspection.
  - o Your intensions.
3. Isolation:
  - o Isolate and Tag/Lock Roof Supports that have not yet advance if working or carrying out inspection on the Shearer.

#### **NO GO ZONE**

Entering a No Go Zone.

1. Communicate with the Deputy to confirm that:
  - o The area has been inspected and safe to enter.
2. Isolation:
  - o Isolate and Tag/Lock all equipment to be worked on and Roof Supports that you are working behind and under.
3. Follow:
  - o All Safe Work Procedures and perform JSA's
  - o Support Rules.



<small>DRAWN</small>	M. Campbell	<b>AUSTAR MINE</b>		
<small>DATE</small>	24/05/2010	<small>TITLE</small>		
<small>CHECKED</small>		NO GO ZONES / OPERATING ZONES during CUTTING for LONGWALL TAILGATE		
<small>APPROVED</small>		<small>SCALE</small>	<small>DRAWING No.</small>	
		NOT TO SCALE	DS147	A4



### 3.3 Tailgate Safety Zones

#### ENTRY TO SAFETY ZONES

##### **OPERATING ZONE**

Operating Zones can be accessed in normal operation at all times.

##### **RESTRICTED ACCESS**

Entering the Restricted Access Zone along the Off Block Side in Tailgate.

1. Communicate by DAC or Phone with the Deputy that you want to enter the Tailgate:
  - o Confirm that the area has been inspected and safe to enter.
  - o Have an gas detector with you if bringing a machine into Tailgate.
  - o Travel up the Off Block Side of the last 10m of the Tailgate.

Entering the Restricted Access Zone behind the Gate Shields.

1. Communicate with the Deputy to confirm that:
  - o The area has been inspected and safe to enter.
  - o You are entering the Restricted Access Zone and Task to be under taken.
2. Isolation:
  - o Isolate and Tag/Lock the Gate Roof Supports that you are working behind and under before entering Restricted Access Zone.

##### **NO GO ZONE**

Entering a No Go Zone.

1. Communicate with the Deputy to confirm that:
  - o The area has been inspected and safe to enter.
2. Isolation:
  - o Isolate and Tag/Lock all equipment to be worked on and Roof Supports that you are working behind and under before.
3. Follow:
  - o All Safe Work Procedures and perform JSA's
  - o Support Rules.



AUSTAR COAL MINE  
ELECTRICAL ENGINEERING

EEMP-S-005

PORTABLE ELECTRICAL APPARATUS  
STANDARD


Rev	Date of Revision	Revision Description	Reviewed By	Approved By
0	20/10/2006	Final Revision	S. Allenby	P McNamara
1	07/09/2007	Implementation Review	S. Allenby	G. Duncan
2	15/02/2008	Laser H&SMP	S. Allenby	G. Duncan
3	18/05/2011	Welder Requirements/SA10-02	S Allenby M. Ingram W. Noble T. Bendeich M. Campbell	

**Table of Contents**

1.0	INTRODUCTION.....	4
2.0	PURPOSE.....	4
3.0	SCOPE.....	5
4.0	GLOSSARY.....	5
5.0	REFERENCES.....	7
6.0	RISK MANAGEMENT.....	8
7.0	SELECTION OF PORTABLE ELECTRICAL APPARATUS.....	8
7.1	Specific Requirements for Non Ex Battery PEA Underground.....	9
7.2	Register of Portable Electrical Apparatus.....	9
7.3	Authorised/Appointment of Personnel – (Underground Only).....	9
7.4	Pre-use inspections.....	9
7.5	Issue Underground Permit (Battery Powered Only).....	10
7.6	Site Inspections (Mains Powered).....	10
7.7	Inspection after Battery PEA Underground After Use.....	10
7.8	Underground Battery Powered PEA Flow Chart.....	11
7.9	Mains Powered PEA Flow Chart.....	12
8.0	CONDITIONS OF USE.....	13
8.1	Mines Department Approved or Certified Portable Electrical Apparatus Underground 13	
8.2	Extension Leads.....	13
8.3	Socket Outlet Assemblies.....	13
8.4	Power Boards.....	13
8.5	Welders.....	14
8.6	Electrical Meter Kits.....	14
8.7	Total Station, Laser Level/Receiver, Vertical Plummet and Rotating Head Laser.....	14
8.8	Requirements for Non Ex Battery PEA Underground.....	15

# APPENDIX

---

	EEMP-S-005
<b>Austar Coal Mine Portable Electrical Apparatus Standard</b>	
<b>8.9</b>	<b>Additional Requirements for Non Ex Battery PEA in the Hazardous Zone ..... 15</b>
<b>8.10</b>	<b>Surface Hazardous Areas (Explosive Gas Atmospheres) ..... 16</b>
<b>9.0</b>	<b>ASSOCIATED DOCUMENTATION ..... 16</b>

## 1.0 INTRODUCTION

There is a wide range of portable electrical apparatus used in the mining industry such as hand held tools, cord sets, note book computers, measuring instruments, electrical test instruments etc.

When using such apparatus there are a range of hazards that must be managed, these include but are not limited to:

- Non-explosion protected apparatus in hazardous zones.
- Apparatus that is constructed of light metal alloys.
- Apparatus in unsuitable environments.
- Apparatus that is not fit for purpose.
- Apparatus above extra low voltage.
- High risk or electrical hostile environments.

As required by the Coal Mines Health and Safety Regulation 2006, Clause 19 Electrical engineering management plan:

The electrical engineering management plan for a coal operation must make provision for the following:

(m), the control of portable electrical plant in the underground parts of the coal operation and, in particular, the use of non-explosion-protected plant in a hazardous zone only under Gazetted conditions,

This plan provides information, detail and arrangements by which Austar Coal Mine will manage and control the risks associated with the use of Portable Electrical Apparatus in hazardous zones, confined spaces, underground and surface operations, to provide a safe and healthy work environment for the mine and all personnel.

## 2.0 PURPOSE

The outcomes sought to be achieved by this standard is to define systems under which Austar Coal Mine will carry out the safe use of portable electrical apparatus, to protect people and property from the risks associated with the use of portable electrical apparatus including but not limited to:

- Electrocution.
- Electric shock.
- Electrical burn injuries.
- Arc blast injuries.
- Injuries sustained through operation of the apparatus.
- Unintended operation of the apparatus.
- Ignitions of flammable mixtures of gas or dust.
- Fire.

3.0 SCOPE


This standard:

- applies whenever portable electrical apparatus is used at Austar Coal Mine including surface areas, confined spaces, underground and hazardous zones.
- covers the selection and use of a range of portable electrical apparatus which includes mains powered, battery powered, explosion protected, non-explosion protected, appliances and test instruments. It also includes associated extension leads/cord sets, cables, plugs, power boards and batteries.
- applies to all portable electrical apparatus whether owned by Austar Coal Mine or brought on site by contractors.

4.0 GLOSSARY

Term	Definition
<b>Hazardous Zone</b>	Coal Mine Health & Safety Regulation 2006, Definitions (1) In this regulation: Hazardous zone means: <ul style="list-style-type: none"> <li>• A return airway in a mine, or</li> <li>• That part of an intake airway in a ventilation district in a mine that is on the return side of such points as are:                             <ul style="list-style-type: none"> <li>○ 100 metres outbye the most inbye completed line of cut-throughs, or</li> <li>○ 100 metres from, and on the intake side of, a longwall or shortwall face, or</li> </ul> </li> <li>• A part of a mine in which there is a methane concentration of 1.25% or greater in the general body of air, or</li> <li>• A part of a mine Gazetted as a hazardous zone.</li> </ul>
<b>Non-Hazardous Zone</b>	<b>Underground</b> Are all areas in the mine not classified as a hazardous zone. <b>Surface</b> Area in which an explosive gas atmosphere is not expected to be present in quantities such as to require special precautions for construction, installation and use of apparatus.
<b>Explosive Atmosphere</b>	Mixture with air, under atmospheric conditions, of flammable substances in the form of gas, vapour, mist or dust, in which after ignition, combustion spreads throughout the unconsumed mixture.
<b>Hazardous Area</b>	<b>AS/NZS 60079.10</b> Area in which an explosive gas atmosphere is present, or may be expected to be present, in quantities such as to require special precautions for the construction, installation and use of apparatus. <b>Zone 0</b> A place in which an explosive atmosphere consisting of a mixture with air of flammable substances in the form of gas vapour or mist is present continuously, for long periods or frequently. <b>Zone 1</b> A place in which an explosive atmosphere consisting of a



	<b>Austar Coal Mine Portable Electrical Apparatus Standard</b>	<b>EEMP-S-005</b>
---	--	-------------------

Term	Definition
	<p>mixture with air of flammable substances in the form of gas, vapour or mist is likely to occur in normal operation occasionally.</p> <p><b>Zone 2</b> A place in which an explosive atmosphere consisting of a mixture with air of flammable substances in the form of gas, vapour or mist is not likely to occur in normal operation but, if it does occur, will persist for a short period only.</p>
<b>Portable Electrical Apparatus (PEA)</b>	Means electrical apparatus capable of being carried manually while it is being used, or referred to in this plan.
<b>Mains Portable Electrical Apparatus</b>	Means electrical apparatus powered by mains electrical power and switchgear, typically 240V ac.
<b>Portable Battery Powered Electrical Apparatus</b>	Means portable electrical apparatus powered by a battery.
<b>Meter Kits</b>	Means meters that are powered by a battery.
<b>Register</b>	List of acceptable Portable Electrical Apparatus to be used at Austar Coal Mine.
<b>Condition of use</b>	Documentation for the conditions of use of Portable Electrical Apparatus.
<b>Mining Official</b>	Mine Manager, Manager of Mining Engineering, Production Manager or People Supervisor.
<b>Fit for purpose</b>	<p>To determine if equipment is considered "Fit for Purpose", there are three things to be considered:</p> <ul style="list-style-type: none"> <li>• The task to be performed.</li> <li>• The ability of the equipment to perform the required task.</li> <li>• Any inherent residual risks based on the equipment design and the task to be performed.</li> </ul> <p>If the residual risks associated with the use of the apparatus for the required task are unacceptable (as defined by Austar risk management system), then the equipment is NOT deemed to be Fit for Purpose.</p>
<b>Confined Spaces</b>	<p>Areas including :</p> <ul style="list-style-type: none"> <li>• Storage tanks, process vessels, boilers, pressure vessels, silos, and other tank like compartments.</li> <li>• Open topped spaces such as pits and degreasers.</li> <li>• Pipes, sewers, shafts, ducts and similar structures.</li> </ul>
<b>Ingress Protection (IP)</b>	A coding system to indicate the degrees of protection provided by an enclosure against access to hazardous parts, ingress of solid foreign objects, ingress of water and to give additional information in connection with such protection.
<b>Class I Portable Powered Apparatus</b>	Equipment in which protection against electric shock does not rely on basic insulation only, but which includes an additional safety precaution, in that conductive accessible parts are connected to the protective earthing conductor in fixed wiring

Term	Definition
	of the installation in such a way that those accessible parts cannot become live in the event of a failure of the basic insulation.
<b>Class II Portable Powered Apparatus</b>	Equipment in which protection against electric shock does not rely on basic insulation only, but in an extra layer of insulation (called "supplementary insulation") is provided to give double insulation, there being no provision for protective earthing or reliance upon insulation conditions. This equipment is generally manufactured with a non-conductive (insulated) enclosure, and is marked either with the words DOUBLE INSULATED or with the symbol to allow easy identification.
<b>Class III Portable Powered Apparatus</b>	Equipment in which protection against electric shock relies on supply at SELV and in which voltages higher than those of SELV are not Generated.
<b>Category I Environment</b>	Includes offices, crib rooms, kitchens, amenities sheds, areas that are not designated as a PPE zones, hostile or electrically hazardous environments.
<b>Category II Environment</b>	Applicable to surface areas where there is no exposure to a hostile or electrically hazardous environment. Includes areas such as switchrooms, substations, winder houses, compressor rooms, muster area etc.
<b>Category III Environment</b>	Applicable to all underground districts, welding bays, workshops, and all hostile and electrically hazardous environments.
<b>Electrically Hazardous</b>	Areas that include damp, dust, other contaminants that increase the risk of electric shock or equipment faults, heat (causing perspiration), humidity, height, reduced lighting, reduced visibility, heavy industrial conditions, risk of mechanical damage and materials handling and moving traffic.
<b>Non Electrically Hazardous</b>	Areas that are clean, dry, well lit, plenty of room, even flooring and insulated flooring.
<b>Hostile Environment</b>	One where the equipment is normally subjected to events or operating conditions likely to result in damage to the equipment or a reduction in its expected life span. This includes, but not limited to physical abuse, exposure to moisture, heat, vibration, corrosive chemicals, mechanical damage and dust.

5.0 REFERENCES

**Applicable Legislation**

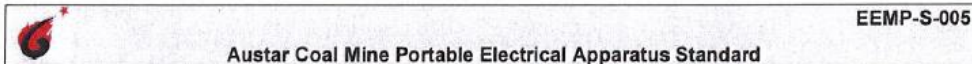
- Coal Mine Health and Safety Act 2002.
- Coal Mine Health & Safety Regulations 2006
- Occupational Health & Safety Regulation 2001
- NSW Government Gazette Notice 5.
- NSW Government Gazette Notice 145.
- EES004 NSW DPI Practices for PEA.

#### 6.0 RISK MANAGEMENT

- Portable Electrical Apparatus selection and assessment shall be carried out to determine that the proposed apparatus is fit for purpose (*Associated Documentation: EEMP-S-021 - Mains Powered PEA Equipment Standard, F0006 – Battery PEA Under Ground Assessment, EEMP-S-011: Welder Standard*).
- Risks associated with the introduction and use of Portable Electrical Apparatus must be assessed and managed in accordance with *H&SMS-004-01: Risk Management Plan*. These include electrical and environmental risks.
- The ALARP process and hierarchy of controls must be applied. Where mains powered PEA can be substituted for battery powered extra low voltage apparatus or air tools they must be considered as an alternative.

#### 7.0 SELECTION OF PORTABLE ELECTRICAL APPARATUS

- Selection criteria is used to prevent situations where portable electrical apparatus is used in situations for which it is unsuitable, exposing personnel to risk of electrical injury or ignition of an explosive atmosphere.
- Persons purchasing or introducing Portable Electrical Apparatus onsite must present this apparatus to a member of the electrical staff for inspection before use.
- All portable electrical apparatus must be fit for purpose and suitable for the intended work environment. A category (I, II, III: refer definitions) must be applied depending on the hazards associated with the environment.
- Conditions for the safe use and operation should be requested by the person introducing the equipment to site and provided by the supplier of the equipment.
- Classes and Ingress Protection (refer definitions) for portable electrical apparatus must be considered when selecting mains powered portable apparatus.
  - The purpose of this requirement is to protect the user and others in the workplace from the risk of electric shock and unintended operation of the apparatus.
  - Selection of apparatus of a particular class will be dependant on the intended environment and service conditions of the apparatus.
  - Portable electrical apparatus shall only be used in areas compatible with the rated Ingress Protection (IP) of the equipment.
  - If IP ratings are not marked on the apparatus, then it must be considered to be unprotected and suitable only to be used in clean & dry environments.
- Mains powered PEA must be in accordance with *EEMP-S-021: Mains Powered PEA Equipment Standard*.
- Battery powered PEA must be in accordance with *F0006: Underground Battery PEA Assessment*.
- Portable Electrical Apparatus shall not have the capabilities to accumulate static charge or be placed in a carrying case that has anti-static properties.
- Restrictions apply to control Portable Electrical Apparatus containing exposed light metal parts from being taken underground.
- Selection criteria should be applied at the time of purchase, hiring, letting of a contract, induction of contractors and job planning.



### Austar Coal Mine Portable Electrical Apparatus Standard

#### 7.1 Specific Requirements for Non Ex Battery PEA Underground

There is a requirement to use Non Ex Battery PEA in the hazardous zone in certain circumstances (camera's, monitoring/measuring equipment etc). Because of the risk of Non Ex/Non Assessed Battery PEA entering the hazardous zone all Battery PEA must be assessed in accordance with *F0002 - Underground Battery PEA Assessment*).

**Mains Powered PEA must be subject to a full risk assessment and DII approval/exemption before being used in the hazardous zone.**

#### 7.2 Register of Portable Electrical Apparatus

- A register for all underground Portable Electrical Apparatus is established at the mine (Associated Documentation: *PAMP-R-001 – Portable Electrical Apparatus Register*).
- To be listed on this register, the equipment must be inspected by a member of the electrical staff and assessed against the appropriate assessment. Once assessed, apparatus that is "Acceptable" will be entered into the register.
- For lasers or equipment containing a laser, the Laser Safety Officer must authorise the use of the equipment. Lasers will not be added to the register until approved by the Laser Safety Officer.
- The register designates the requirements for use and inspection criteria.
- Persons introducing or decommissioning the apparatus are responsible for notifying a member of the electrical department to allow the register to be updated.

#### 7.3 Authorised/Appointment of Personnel – (Underground Only)

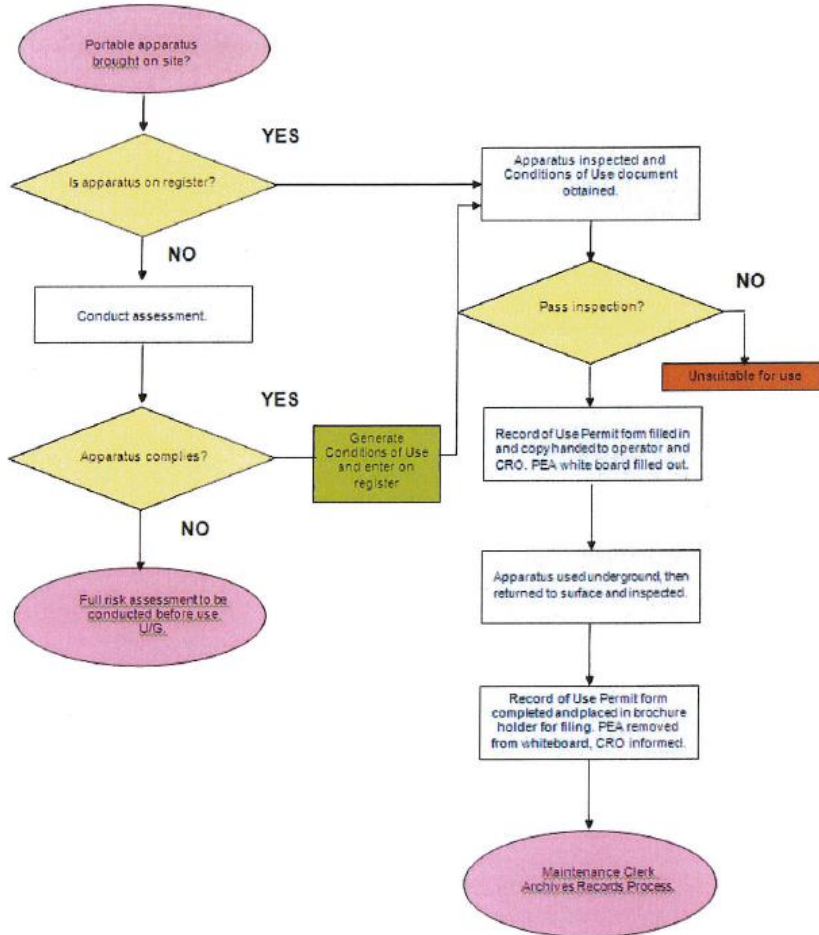
- For persons to be authorised to operate Portable Electrical Apparatus underground, they will have had to complete the competency based assessment on this standard.
- For persons to operate Portable Electrical Apparatus underground in the Hazardous Zone they must be appointed by the Manager of Mining Engineering.
- Verification that a person is authorised/appointed must be confirmed against the training data base "Scenario".
- Where there is a requirement for a non authorised person to operate portable electrical apparatus underground the Shift Supervisor can approve persons to operate Portable Electrical Apparatus under the direct supervision of:
  - Authorised person non hazardous zone.
  - Appointed person hazardous zone.
- For persons to use battery powered meter kits they must also be appointed as an Electrical Technician at Austar Coal Mine.

#### 7.4 Pre-use inspections

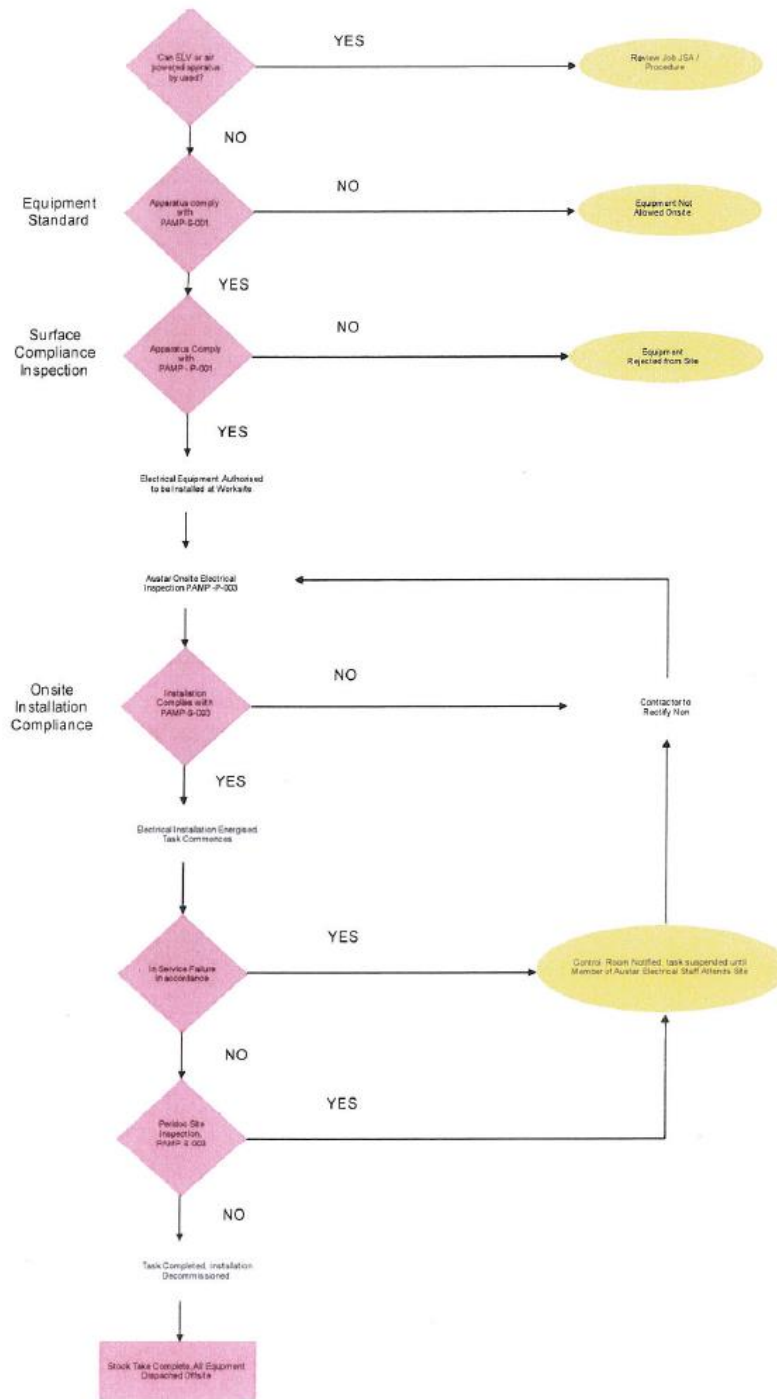
- The purpose of this pre-use inspection is to prevent exposure of personnel to electrical hazards that could arise if unsuitable apparatus is used in damp, dusty or otherwise arduous environments. The range of hazards can include electric shock, burns, and unintended operation of the apparatus.
- Pre-use inspections must be carried out on all Mains Powered PEA before surface use (contractors only) or being taken underground.
- The contract holder is responsible for ensuring that Mains Powered PEA used by contractors is presented to the electrical department for inspection (*Associated Documentation: F0005 - Mains Powered PEA Assessment*).

- Pre-use inspections must be carried out on all non Ex Battery Powered Portable Electrical Apparatus prior to being taken underground. The results of these inspections shall be recorded on the record of use permit. (*Associated Documentation: F0008: Record of Use Permit of PEA Underground*).
- 7.5 Issue Underground Permit (Battery Powered Only)
- If the apparatus passes the pre use inspections a permit form for record of use shall be filled in prior to the apparatus being taken underground. The white copy is to be carried with the PEA whilst underground, the yellow copy must be handed to the control room operator and the PEA white board filled out in the control room (*Associated Documentation: F0008 – Record of Use Permit*).
- 7.6 Site Inspections (Mains Powered)
- Where equipment above extra low voltage is being used underground an inspection of the installation must be completed by an Austar Electrical Technician prior to work commencing. (*Associated Documentation: F0007 – PEA Installation Inspection*).
  - The site supervisor is responsible for ensuring that standards are maintained after the Austar Electrical Technician has handed over the site. The site supervisor will receive *F007 – PEA Installation Inspection*.
  - The site supervisor must return the completed copy of *F007 – PEA Installation Inspection* to the PEA brochure holder.
  - The above inspections may be required by the Manager of Electrical Engineering at any place where Portable Electrical Apparatus will be used.
- 7.7 Inspection after Battery PEA Underground After Use
- The purpose of this requirement is to confirm that equipment taken underground has been returned to the surface, and identify equipment and any practices that result in damage in service, as well as identify equipment that does not stand up to the rigors of underground use.
  - On return to the surface the portable apparatus must be inspected for damage by an Austar Electrical Technician. If an Austar Electrical Technician is not available the supervisor or permit holder must complete the inspection.
  - Record of Use Permit Form has the provision to record its return and any defects found.
  - Any damage to the equipment shall be processed as per Austar Coal Mine Defect Safety Management Plan H & SMS 006-2 or Accident Investigation Procedure.

7.8 Underground Battery Powered PEA Flow Chart



7.9 Mains Powered PEA Flow Chart



## 8.0 CONDITIONS OF USE

### 8.1 Mines Department Approved or Certified Portable Electrical Apparatus Underground

The apparatus:

- Listed on the Register of Portable Electrical Apparatus before being allowed to be taken underground (*Associated Documentation: PAMP-R-001 – Portable Powered Electrical Apparatus Register*).
- Used in accordance with the Conditions of Use document and manufactures instructions, certificate of conformity and/or MDA approvals for that apparatus.
- Made available for inspections as required by Austar Coal Mine Electrical Maintenance System.
- Any defect identified while the apparatus is underground shall necessitate the immediate removal of the apparatus from the mine and the defect reported to a member of the electrical staff.

### 8.2 Extension Leads

- Must comply with *EEMP-S-021: Mains Powered PEA Equipment Standard*.
- Replacement of leads & plugs on appliances must only be carried out by an appointed electrical technician or authorised electrical contractor.
- Risk controls for Austar Coal Mine include :
  - Limitation of the length of extension leads and a combination of extension leads to avoid a voltage drop to the appliance of greater than 5%.
  - Double adaptors are prohibited.
  - Prevention of mechanical damage, damage by liquids or damage by high temperatures occurring to flexible cords and cables.
  - Provision of flexible cords and cables with suitable protection against mechanical damage, or protection by location.
  - Provision of stands or hangers for flexible cords and cables so that they are supported off the ground or floor. Stands or hangers should be covered with material that is non-conducting and will prevent mechanical damage to the cable.

### 8.3 Socket Outlet Assemblies

Comply with *EEMP-S-021: Mains Powered PEA Equipment Standard*.

Socket-outlets mounted on the assembly shall be protected against damage by suitable means such as covers or extended sides.

### 8.4 Power Boards


Comply with *EEMP-S-021: Mains Powered PEA Equipment Standard*.

Power boards are more prone to damage, contamination and wear and tear due to their portability and upward facing sockets.

Risk controls include the following:

- Multiple or cascaded power boards must not be used.
- Double adaptors are prohibited for use at Austar Coal Mine.
- Regularly check for signs of damage or heating and that sockets firmly grip the plug when inserted.



	<b>Austar Coal Mine Portable Electrical Apparatus Standard</b>	<b>EEMP-S-005</b>
---	--	-------------------

- When used outdoors or in dusty or polluted environments such as workshops and building sites additional protection may be required.
- Power boards should not be used in wet areas or areas where there is likely to be water present.
- Power boards that have been subjected to moisture or are in any way damaged must be withdrawn from service and inspected.

#### 8.5 Welders

Some welding machines are inherently safer than others, for example dc welders are recognised as safer than ac welders. Risk controls known as hazard reduction devices (HRD's) are now commonly used as an effective risk control.

Welding machines can be a source of electric shock and they are widely used. Operations carried out at mines can increase the risk of electric shock or electrocution. Selection of the safest welding machine and HRD (Hazard Reduction Device) arrangements is critical.


*(Associated Documentation: Welder Standard – EEMP-S-011)*

#### 8.6 Electrical Meter Kits

- The apparatus contained in electrical powered battery meter kits must be fit for service and suitable for its intended environment, listed on the register of Portable Powered Electrical Apparatus before being allowed to be taken underground. They do not require a permit to be filled out prior to taking them underground.
- The person who will be operating the meter kit underground must be appointed to operate Portable Electrical Apparatus and appointed as an Electrical Technician.
- The meter kit is to be inspected by the electrical technician for damage prior to going underground and into the hazardous zone. If found to be damaged or faulty it must be tagged out of service and not taken underground or into the hazardous zone.
- The condition of the meter kit shall be recorded on the electricians shift report, along with any problems that may have been encountered during the shift.
- Meter kits used underground will be kept in the crib room of the panel in which the electrician is working unless there is a need for the electrician to be using the meter kit. Meter kits are not to be left unattended when not in the crib room. (i.e. section DCB).
- The meter kit will not be taken into any hazardous zone except in accordance with relevant sections of clause 8.9.
- Each meter kit will be returned to the surface at the completion of the shift.

#### 8.7 Total Station, Laser Level/Receiver, Vertical Plummet and Rotating Head Laser

- Survey Total Station, Laser Level / Receiver, Vertical Plummet and Rotating Head Laser shall be listed on the register of Portable Powered Electrical Apparatus before being allowed to be taken underground. They do not require a permit to be filled out prior to taking them underground.
- The person who will be operating the Survey Total Station, Laser Level/Receiver, Vertical Plummet or Rotating Head Laser underground in the hazardous zone must be appointed by the Operators Site Representative as a Surveyor
- A person not appointed as a Surveyor may operate a Laser Level Receiver underground in accordance with clause 7.3 (i.e. belt crew).
- The Survey Total Station, Laser Level/Receiver, Vertical Plummet and Rotating Head Laser must be inspected by the surveyor for damage prior to going underground and into the hazardous zone. If found to be damaged or faulty it shall be tagged out of service and shall not be taken underground or into the hazardous zone.

	<b>Austar Coal Mine Portable Electrical Apparatus Standard</b>	<b>EEMP-S-005</b>
---	--	-------------------

- When underground the Survey Total Station, Laser Level/Receiver, Vertical Plummet and Rotating Head Laser will be under the control of the Surveyor.
  - The Survey Total Station, Laser Level/Receiver, Vertical Plummet and Rotating Head Laser must not be taken into any hazardous zone except in accordance with relevant sections of clause 8.9.
  - The Survey Total Station, Laser Level/Receiver, Vertical Plummet and Rotating Head Laser must be returned to the surface at the completion of the shift.
- 8.8 Requirements for Non Ex Battery PEA Underground
- Permit Form for Record of Use shall be filled in prior to the apparatus being taken underground. (*Associated Documentation: F0008 – Record of Use Permit*).
  - The equipment is to be inspected by an appointed electrical technician for damage prior to going underground, and if found damaged or faulty, the equipment must be tagged Out of Service and **SHALL NOT** be taken underground.
  - The inspecting appointed electrical technician must complete the relevant section of the "Record of Use Permit Form" and sign and date the form.
  - The inspecting appointed electrical technician will attach an inspection sticker across the battery opening to prevent removal while underground. Batteries must not be replaced underground.
  - PEA whiteboard must be filled out prior to the apparatus being taken underground, the Control Room Operator notified and the yellow copy of the Conditions of Use Permit given to the Control Room Operator.
  - The original of the permit form shall be carried with the apparatus at all times while underground.
  - Any defect identified while the apparatus is underground shall necessitate the immediate removal of the apparatus from service and the defect reported to a member of the electrical staff.
  - When the apparatus is returned to the surface it must be inspected for damage, permit completed, PEA removed from whiteboard, CRO notified and the original copy (white copy) of the permit placed in the PEA brochure holder.
  - The maintenance clerk shall archive the permits weekly.
- 8.9 Additional Requirements for Non Ex Battery PEA in the Hazardous Zone
- Where portable apparatus is to be used in a hazardous zone, gas clearance conditions below apply:
    - The area in which the instrument is to be used shall be inspected by a Mining Official for levels of CH<sub>4</sub> above 0.5% before the apparatus is taken into the hazardous zone.
    - The area must be continuously monitored for the duration of the time the apparatus is in the hazardous zone by the Mining Official or competent person.
    - If methane levels in excess of 0.5% are found, or a risk identified that may result in methane levels exceeding 0.5%, the apparatus must be removed to a safe place.
    - The level of methane in the general body of air within all safely accessible places within 20 metres of the apparatus is maintained at less than 0.5% and must have regard for a sudden contamination of an area by a flammable gas mixture, for example in the event of a goaf fall or ventilation failure.

**Austar Coal Mine Portable Electrical Apparatus Standard**

- Any examination for explosive mixture and gas clearance should extend to all areas that include the instrument and circuit under test (cable).
- Gas clearance for equipment nominated in clause 8.6 and 8.7 must be recorded on the:
  - Mining Officials statutory shift report for survey equipment and meter kits.
  - Record of Use Permit for all other equipment.

The detail will include maximum methane level detected and mining official authorising gas clearance.

- The apparatus must not be connected to a circuit or cable that is in part or total located in a hazardous zone unless the apparatus has been assessed as suitable for use in a hazardous zone, and the conditions for use in a hazardous zone are complied with.
- Should the main fans stop or the ventilation fail in the area in which the apparatus is being used, the apparatus is to be shut down and removed to a safe place.
- The control room operator is to contact the user of the apparatus and advice of the ventilation failure and the areas affected.
- Battery or mains powered rotating apparatus e.g. drills are not permitted in a hazardous zone.

**8.10 Surface Hazardous Areas (Explosive Gas Atmospheres)**

- The tube bundle installation at 3 Shaft has been identified as a Hazardous Area.
- It is the responsibility of the person making any change to surface infrastructure or installations to assess any changes to the existing zone classification and ensure that the survey is updated and the Manager of Electrical Engineering formally notified.
- Classified areas will be divided into zones. (Zone 0, Zone 1, Zone 2) based upon the frequency of the occurrence and duration of an explosive gas atmosphere (For area classification refer to AS/NZS 60079.10 2004).
- Classified areas must be signposted and displayed on Surface Plan.
- All classified areas that require the use of Portable Electrical Apparatus must meet the guidelines for Portable Electrical Apparatus that can be used in hazardous zones.

**9.0 ASSOCIATED DOCUMENTATION**

- F0001 Mains Powered PEA Assessment.
- F0006 Underground Battery PEA Assessment.
- F0007 PEA Installation Inspection.
- F0008 Record of Use Permit.
- EEMP-P-016 Mains Powered PEA UG Conditions of Use.
- EEMP-P-017 Battery Powered PEA UG Conditions of Use.
- F0009 Battery Powered PEA Underground Inspection.
- EEMP-P-018 Meter Kits Conditions of Use.
- EEMP-S-021 Mains Powered PEA Equipment Standard.
- EEMP-S-022 Contractor Mains Powered PEA Introduction to Site.
- EEMP-S-011 Welder Standard.
- PAMP-R-001 Portable Powered Electrical Apparatus Register.





**Risk Assessment - Exposure to excessive dust levels to operators on Longwall face, during planned testing without available water dust suppression)**

**Title**

**Department:** Longwall Department.

**Topic:** Exposure to excessive dust levels to operators on Longwall face, during planned testing without available water dust suppression)

**Venue:** Longwall Office

**Requested By:** Andy Clowes

**Date:** 3/9/10

**Time** 9.30am

**Facilitator:** Brad Phillips

**Note Taker:**

**Attendees**

<b>Name</b>	<b>Position (RA Role)</b>	<b>Experience</b>	<b>Signature</b>
Brad Phillips	Snr Compliance Advisor	25 yrs	
Brian Plush	Ventilation Engineer	30 yrs	
Nick Foster	Operator/trainer Assessor	4 yrs	
Ian Kearsley	Fitter	25 yrs	
Paul Osborn	Miner	13 yrs	
Grace Robinson	Safety Advisor	18 yrs	
Bill Laing	Operator	12 yrs	
Andrew Baillie	Crew Supervisor	32 yrs	
Andrew Clowes	Longwall Coordinator	25yrs	

**1. Overview<sup>1</sup>**

The University of Wollongong has prepared an intense study on dust exposure levels to personnel operational in Longwall processes, with the focus on measuring/evaluating the efficiency of existing dust controls with the view for determining a measurable means for continual improvement. The study involves using a measuring process through robust and quantitative sampling methods & equipment, to ensure the most effective controls are in place. It is planned to measure the dust levels throughout the entire longwall operation with strategically positioned sampling devices. The sampling process is planned to measure dust loads during operations with no dust controls in place for a determined period, then with dust controls in place for the same operational time period.

<sup>1</sup> What is the physical environment and what is the relationship of the activity under review to the operation as a whole? This may include geological, geotechnical and geographical data, a brief description of similar mining operations previously in the area, and levels of support available from internal and external providers. Clearly state the presence of any significant hazards in previous or continuing mines in the area. Also include a description (with diagrams if necessary) of the activity being assessed and types of mining machinery and methods of coal winning.

LAST REVIEW DATE DD/MM/YY	NEXT REVIEW DATE DD/MM/YY	REVIEW NO 0	DOCUMENT OWNER	PAGE 2 of 14
Print Date: 23/11/2012		Uncontrolled Document When Printed		

## APPENDIX

---



INTEGRA

**Risk Assessment - *Exposure to excessive dust levels to operators on Longwall face, during planned testing without available water dust suppression***

---

The Longwall department has planned to conduct this testing process, with the aim for continual improvement of dust levels involving Longwall operations at the Integra site.

LAST REVIEW DATE DD/MM/YY	NEXT REVIEW DATE DD/MM/YY	REVIEW NO 0	DOCUMENT OWNER	PAGE 3 of 14
Print Date: 23/11/2012		Uncontrolled Document When Printed		



**Risk Assessment - *Exposure to excessive dust levels to operators on Longwall face, during planned testing without available water dust suppression***

**2. Objective**

*Define the objective of the risk assessment. Ask, "What do we want to achieve by conducting this risk assessment?"*

The objective for conducting this risk assessment is to identify a means of operating the Longwall operation without dust suppressing controls, with the view to controlling any adverse health/dust conditions that personnel may be exposed to during this testing process.

**3. Scope**

*The WRAC methodology will be used, utilising CVRD Australia Pty Ltd Risk Matrix and SMS Standard 3.2 Risk Management Framework.*

*Who and where does this risk assessment and the outcomes of the risk assessment apply?*

The risk assessment will be undertaken within the following boundaries during the testing process, with consideration to:

- Exposure levels to operators of both respirable & inhalable dust during testing processes.
- Assessing the hazards and possible health risks associated with excessive dust levels during the testing/measurement process.
- Develop Control strategies for any identified hazards & risks relative to adverse health effects during the testing process.
- Position of operators or proximity of personnel, during the testing process.

PPE requirement during the testing process.

**4. Stakeholders**

*Who are the people affected by the outcome of the risk assessment?  
How will they be notified of the outcome? E.g. Toolbox talk, Memo, SOP*

The stakeholders, in relation to the impacts of this study, are as follows:

- Integra Longwall Department.
- LW & shift Supervisor.
- Longwall personnel

The Risk assessment team concluded that a list of additional PPE & first aid supplies be available in the section during the testing arrangements/process, as well as communicating to the work force prior to the testing arrangements, and limiting the access to the longwall face areas during testing processes.

LAST REVIEW DATE DD/MM/YY	NEXT REVIEW DATE DD/MM/YY	REVIEW NO 0	DOCUMENT OWNER	PAGE 4 of 14
Print Date: 23/11/2012		Uncontrolled Document When Printed		



INTEGRA

**Risk Assessment - *Exposure to excessive dust levels to operators on Longwall face, during planned testing without available water dust suppression***

---

LAST REVIEW DATE DD/MM/YY	NEXT REVIEW DATE DD/MM/YY	REVIEW NO	DOCUMENT OWNER	PAGE
		0		5 of 14
Print Date: 23/11/2012			Uncontrolled Document When Printed	





## 6. Reference Material

To assist in the identification of hazards, a team must review applicable associated SOP's, Risk Assessments, Management Plans, Legislation (Coal or other), Industry Hazard Database, Site Incident & Hazard Data Base and accident/incident reports.

**Reference material:**

- HMP\_0112 Airborne dust
- Hierarchy of controls (Handout)
- Nertney Wheel (Handout)
- Risk Assessment preliminary review.
- University of Wollongong Testing project descriptor document.

## 7. Risk Assessment Summary

*What is a summary of the hazards and controls identified? Include a brief explanation of group outcomes and discussions. Are there any hazards defined as unacceptable?*

The hazards identified during the risk assessment process include:

- Inhalation of dust in suspension above normal levels.
- 

The controls identified during the risk assessment process, are as follows:

- 

No hazards were identified as being unacceptable.

This risk assessment has been prepared from the information supplied by the Risk assessment team on the day.

- Ensure airstream helmets availability.
- Ensure goggles are available.
- Ensure Dust masks are available
- Ensure additional eye wash is available in section
- Minimum access to personnel on face area.
- Communicate testing arrangements, prior to testing commencing, method- toolbox talk address at start of shift.

LAST REVIEW DATE DD/MM/YY	NEXT REVIEW DATE DD/MM/YY	REVIEW NO	DOCUMENT OWNER	PAGE
		0		6 of 14
Print Date: 23/11/2012			Uncontrolled Document When Printed	



**Risk Assessment - Exposure to excessive dust levels to operators on Longwall face, during planned testing without available water dust suppression)**

RSK\_XXXX

**8. Workplace Risk Assessment and Control Worksheet (WRAC)**

Risk Assessment							
Job Step	Hazard	Existing controls	Consequence	Likelihood	Risk Rating	Proposed Controls	
<b>Shearer driver.</b> During shearer Operation , without dust suppression.	Dust in suspension above normal levels	<ul style="list-style-type: none"> <li>Ventilation</li> <li>PPE (Dust mask- Air stream helmet)</li> <li>Shearer sprays</li> <li>Safe Standing Zones</li> <li>SRB.</li> </ul>	2	D	L21	<ul style="list-style-type: none"> <li>Ensure airstream helmets available.</li> <li>Ensure goggles are available.</li> <li>Ensure Dust masks are available</li> <li>Ensure additional eye wash is available in section</li> <li>Minimum access to personnel on face area.</li> </ul>	L21
<b>Shield operator</b> During shearer Operation , without dust suppression.	Dust in suspension above normal levels	<ul style="list-style-type: none"> <li>Ventilation</li> <li>PPE (Dust mask- Air stream helmet)</li> <li>Shearer sprays</li> <li>Safe Standing Zones</li> <li>SRB.</li> </ul>	2	D	L21	<ul style="list-style-type: none"> <li>Ensure airstream helmets available.</li> <li>Ensure goggles are available.</li> <li>Ensure Dust masks are available</li> <li>Ensure additional eye wash is available in section</li> <li>Minimum access to personnel on face area.</li> </ul>	L21

LAST REVIEW DATE DD/MM/YY	NEXT REVIEW DATE DD/MM/YY	REVIEW NO 0	DOCUMENT OWNER	PAGE 7 of 14
Print Date: 23/11/2012		Uncontrolled Document When Printed		



**Risk Assessment - Exposure to excessive dust levels to operators on Longwall face, during planned testing without available water dust suppression)**

RSK\_XXXX

<p><b>Main Gate Operator.</b> During Shearer Operation, without dust suppression.</p>	<p>Dust in suspension above normal levels</p>	<ul style="list-style-type: none"> <li>• Ventilation</li> <li>• PPE (Dust mask- Air stream helmet)</li> <li>• Shearer sprays</li> <li>• Safe Standing Zones</li> <li>• SRB.</li> </ul>	<p>2</p>	<p>D</p>	<p>L21</p>	<ul style="list-style-type: none"> <li>• Ensure airstream helmets available.</li> <li>• Ensure goggles are available.</li> <li>• Ensure Dust masks are available</li> <li>• Ensure additional eye wash is available in section</li> <li>• Minimum access to personnel on face area.</li> </ul>	<p>L21</p>
<p><b>Pan Push operation</b> During shearer Operation, without dust suppression.</p>	<p>Dust in suspension above normal levels</p>	<ul style="list-style-type: none"> <li>• Ventilation</li> <li>• PPE (Dust mask- Air stream helmet)</li> <li>• Shearer sprays</li> <li>• Safe Standing Zones</li> <li>• SRB.</li> </ul>	<p>2</p>	<p>D</p>	<p>L21</p>	<ul style="list-style-type: none"> <li>• Ensure airstream helmets available.</li> <li>• Ensure goggles are available.</li> <li>• Ensure Dust masks are available</li> <li>• Ensure additional eye wash is available in section</li> <li>• Minimum access to personnel on face area.</li> </ul>	<p>L21</p>
<p>Pedestrians accessing face during testing process</p>	<p>Dust in suspension above normal levels</p>	<ul style="list-style-type: none"> <li>• Ventilation</li> <li>• PPE (Dust mask)</li> <li>• Shearer sprays</li> <li>• Safe Standing Zones</li> <li>• SRB.</li> <li>• Longwall orientation</li> <li>• HMP_0112</li> </ul>	<p>2</p>	<p>D</p>	<p>L21</p>	<ul style="list-style-type: none"> <li>• Toolbox at start of shift</li> <li>• Minimum access to personnel on face area.</li> </ul>	<p>L21</p>

<p>LAST REVIEW DATE DDMMYY</p>	<p>Print Date: 23/11/2012</p>	<p>NEXT REVIEW DATE DDMMYY</p>	<p>REVIEW NO 0</p>	<p>DOCUMENT OWNER Uncontrolled Document When Printed</p>	<p>PAGE 8 of 14</p>
------------------------------------	-------------------------------	------------------------------------	------------------------	--	-------------------------



**Risk Assessment - Exposure to excessive dust levels to operators on Longwall face, during planned testing without available water dust suppression)**

RSK\_XXXX

Deputy's Inspection during testing process	Dust in suspension above normal levels	<ul style="list-style-type: none"> <li>• Ventilation</li> <li>• PPE (Dust mask)</li> <li>• Shearer sprays</li> <li>• Safe Standing Zones SRB.</li> <li>• Longwall orientation HMP_0112</li> </ul>	2	D	L21	<ul style="list-style-type: none"> <li>• Toolbox at start of shift</li> <li>• Minimum access to personnel on face area</li> </ul>	L21
Tradesman duties during testing process	Dust in suspension above normal levels	<ul style="list-style-type: none"> <li>• Ventilation</li> <li>• PPE (Dust mask)</li> <li>• Shearer sprays</li> <li>• Safe Standing Zones SRB.</li> <li>• Longwall orientation HMP_0112</li> </ul>	2	D	L21	<ul style="list-style-type: none"> <li>• Toolbox at start of shift</li> <li>• Minimum access to personnel on face area.</li> </ul>	L21

LAST REVIEW DATE DDMMYY	NEXT REVIEW DATE DDMMYY	REVIEW NO 0	DOCUMENT OWNER	PAGE 9 of 14
Print Date: 23/11/2012 Uncontrolled Document When Printed				



**Risk Assessment - Exposure to excessive dust levels to operators on Longwall face, during planned testing without available water dust suppression)**

RSK\_XXXX

**9 Prioritising the Risk prior to the Additional Controls**

*The following lists should be ranked in a manner, which indicate matters in order of priority to assist the decision making process used to ascertain which risk will be treated first and what resource effort is required to achieve an acceptable level of risk.*

Hazard	Risk Ranked by Risk Magnitude
Dust in suspension above normal levels	L21

Hazard	Risk Ranked by Consequence Magnitude
Dust in suspension above normal levels	2

**10. Identify any Unquantified Hazards**

*Include assumed risk. That is, where data has been unable to be substantiated by either scientific or historical means. The assumed figures will need to be confirmed by direct measurement as soon as reasonably practical. An example of Unquantified Hazards could be the amount of flammable gas in a coal seam that has not been drilled or tested as yet.*  
Nil

LAST REVIEW DATE DDMMYY	NEXT REVIEW DATE DDMMYY	REVIEW NO 0	DOCUMENT OWNER	PAGE 10 of 14
Print Date: 23/11/2012		Uncontrolled Document When Printed		



**Risk Assessment - Exposure to excessive dust levels to operators on Longwall face, during planned testing without available water dust suppression)**

RSK\_XXXX

**11. Risk Control & Management Action Plan**

<b>Action Plan</b>		
<b>Risk Assessment:</b>	<b>Exposure to excessive dust levels to operators on Longwall face, during planned testing without available water dust suppression)</b>	
<b>Date Raised:</b>	3/9/2010	<b>Department:</b> Longwall
<b>Facilitator:</b>	Brad Phillips	

Priority	Actions	Responsibility	Due Date
1.	<ul style="list-style-type: none"> <li>Ensure air-stream helmets available. <i>(Prior to testing commencing)</i></li> <li>Ensure goggles are available. <i>(Prior to testing commencing)</i></li> <li>Ensure Dust masks are available in section. <i>(Prior to testing commencing)</i></li> <li>Ensure additional eye wash is available in section. <i>(Prior to testing commencing)</i></li> </ul>	Andy Clowes.	<ul style="list-style-type: none"> <li><i>(Prior to testing commencing)</i></li> </ul>
2.	<p>Compile toolbox talk for start of Shift address, prior to testing commencing. Toolbox talk to include mention of limited access to longwall production areas, during testing, due to potential higher levels of dust, due to dust suppression water system turned off.</p>	Andy Clowes.	<ul style="list-style-type: none"> <li><i>(Prior to testing commencing)</i></li> </ul>

LAST REVIEW DATE DDMMYY	NEXT REVIEW DATE DDMMYY	REVIEW NO 0	DOCUMENT OWNER	PAGE 11 of 14
Print Date: 23/11/2012		Uncontrolled Document When Printed		

 <b>VALE</b>	<b>Risk Assessment - Exposure to excessive dust levels to operators on Longwall face, during planned testing without available water dust suppression)</b>	RSK_XXXX
--	--	----------

--	--	--	--	--

Sign off when complete  
 Manager Name \_\_\_\_\_ Date \_\_\_\_\_  
 Signature \_\_\_\_\_  
**Authorisation:** \_\_\_\_\_

**Note: - Method of Monitoring.** Once Action Plan is completed, Issue these actions to the Document Controller for uploading into the BIP system.

LAST REVIEW DATE DDMMYY	NEXT REVIEW DATE DDMMYY	REVIEW NO 0	DOCUMENT OWNER Uncontrolled Document When Printed	PAGE 12 of 14
Print Date: 23/11/2012				

# APPENDIX

	<b>Risk Assessment -</b>	RSK_XXXX
---	--------------------------	----------

## 12. Non-Consensus Matters

For documented evidence, this section verifies by signature, should consensus not be achieved. The concerns of dissenting persons must be detailed in the section below. **(If all participants agree, this section is not applicable.)**

Nil

Name	Reason for Non Consensus	Signature	Date

LAST REVIEW DATE DD/MM/YY	NEXT REVIEW DATE DD/MM/YY	REVIEW NO 0	DOCUMENT OWNER	PAGE 13 of 14
Print Date: 23/11/2012		Uncontrolled Document When Printed		





**Risk Assessment -**

RSK\_XXXX



**Risk Assessment Matrix**

Loss Type	Insignificant 1	Minor 2	Moderate 3	Major 4	Catastrophic 5
People Health & Safety (P)	Slight injury or health effects – first aid/ minor medical treatment level	Minor injury/health effects requiring medical attention/first aid/first-aid work restriction/assignment	Major injury/health effects requiring emergency/medical assistance and long term work restriction/assignment	Single fatality, major injury/health effects requiring extensive medical services with permanent disablement	Multiple fatalities (> 5) or multiple serious injuries/impacts on health (> 5) ultimately fatal
Business Interruption (BI)	Easily addressed or rectified by immediate corrective action. Loss of production less than 1 day	Minor or superficial damage to equipment and/or facility. Loss of production 1 day to 1 week	Moderate damage to equipment and/or facility. Loss of production 1 week to 1 month	Major damage to facility requiring significant corrective/preventive action. Loss of production > 3 months	Future operations at site seriously affected. Urgent corrective/ remedial action. Loss of production > 3 months
Reputation, (R)	Slight impact – public awareness may exist but no public concern	Unmet impact – some local public concern	Considerable impact – regional public concern	National impact – national public concern	International impact – international public concern
Regulatory Compliance (C)	Low-level legal issue	Minor legal issues, non-compliances and breaches of regulation. Formal investigation issued. Mine Record note / issued	Serious breach of regulation with investigation or report to authority with potential for prosecution. Moderate fine	Major breach of regulation with prosecution by authority and/or potential major fine	Significant prosecution and fines. Very serious litigation including class actions.
Environmental Impact (E)	Unlimited damage to minimal area of low significance. No clean up.	Minor effects on biological or physical environment. Minor clean up.	Moderate, short term, effects but not affecting the ecosystem function. Major clean up.	Serious, medium term, local ecosystem damage - significant clean up.	Very serious, long term, regional ecosystem damage - major rehab failure, site closure.
Social (S)	Short term and/or local slight impact on local population and/or industries - Reguarate damage	Medium term and/or minor local impact on local population and/or industries - Moderate Reguarate damage	Permanent and/or significant local impact on local population and/or industries - Major Reguarate damage	Medium term and/or minor regional impact on local population and/or industries - Moderate Reguarate damage	Permanent and/or significant regional impact on highly valued items.
Impact \$ (F)	<US \$10K	US \$10K to \$100K	US \$100K to \$1M	US \$1M to \$10M	>US \$10M to \$100M

Likelihood		Risk Rating				
Almost Certain (A)	The event is expected to occur in the circumstances (once per month)	M (15)	H (10)	H (6)	E (2)	E (1)
Likely (B)	Will probably occur in most circumstances (once per year)	M (19)	M (14)	H (9)	E (4)	E (3)
Possible (C)	Might occur at some time (once per 10 years)	L (22)	M (18)	H (13)	H (8)	E (5)
Unlikely (D)	Could occur at some time (once per 100 years)	L (24)	L (21)	M (17)	H (12)	H (7)
Rare (E)	May occur only in exceptional circumstances (once per 1000 years)	L (25)	L (23)	M (20)	M (16)	H (11)

LAST REVIEW DATE DDMMYY	NEXT REVIEW DATE DDMMYY	REVIEW NO 0	DOCUMENT OWNER	PAGE 14 of 14
Print Date: 23/11/2012				Uncontrolled Document When Printed

Appendix 5 Risk Assessment for Shearer Testing

**ILLAWARRACOAL**

Pride, passion, performance.

Appin Mine  
Metallurgical Coal  
BHP Billiton Limited

<b>RISK ASSESSMENT</b>	
DEPARTMENT: LONGWALL	
TITLE OF DOCUMENT: <b>UNIVERSAL AIR SAMPLING PUMP MOUNTED ON SHEARER FOR TESTING INHALABLE DUST</b>	
PREPARED BY: ALEX SAKUN	
TITLE:	



**Assessment Team:**

<i>Name</i>	<i>Role and Qualifications</i>	<i>Location</i>
Alex Sakun	31 years in underground coal	Illawarra Coal
Tim Smith	12 years in underground coal, Deputies qualifications	Illawarra Coal
Brian Plush	Masters Degree	Envirocon Consultant

**REVIEW**

Date	Version	By	Reason
23/03/2012	1.0	Alex Sakun	Initial Document



	<i>This document is valid 24hrs from time printed</i>	Page 1 of 16
	Document ID: APNRAxxxx      Version: 1.0 Last Review Date: 23/02/11	

**TABLE OF CONTENTS**

**1. EXECUTIVE SUMMARY..... 3**

**1.1 PURPOSE..... 3**

**1.2 OBJECTIVES AND SCOPE..... 4**

**1.3 DEFINITIONS ..... 7**

**1.4 RISK MANAGEMENT PROCESS STEPS..... 8**

**1.5 BHP HSE CONSEQUENCE SEVERITY RANKING TABLE..... 9**

**1.6 LIKELIHOOD RANKING TABLE ..... 10**

**1.7 RISK MATRIX ..... 11**

**2. KEY ASSUMPTIONS ..... 12**

**3. RISK ASSESSMENT TEAM ..... 12**

**4. RISK TABLE..... 13**

**5. RISK REDUCTION VERIFICATION FORM ..... 16**



	<i>This document is valid 24hrs from time printed</i>	
	Document ID: APNRAxxxx      Version: 1.0 Last Review Date: 23/02/11	Page 2 of 16

# APPENDIX

## Risk Assessment Universal Air Sampling Pump Mounted On Shearer For Testing Inhalable Dust

### 1. EXECUTIVE SUMMARY

Via BHP Billiton approval, Appin Mine Longwall Department are working in-conjunction with a consultant to Envirocon who is doing his Wollongong University PhD thesis on Longwall Dust Controls. This is funded via an ACARP grant.

To gain a better understanding of “benchmark” dust loads a request to install two Exia Universal Air Sampling Pumps mounted securely under the shearer sloughing plate, with tubes run out to a sensing head on either the tailgate and Maingate spray arms tied securely.

This risk assessment has identified the potential hazards of using this Exia equipment safely for the purpose in a hazardous zone and the appropriate control measures that will be required for its safe operation.

The Universal Air Sampling Pumps are exactly the same units as used throughout the coal mining industry for measuring dust samples as taken by Coal Services and others.

Detail on the electrical apparatus is as follows:

<b>Electrical Apparatus:</b>	Universal Air Sampling Pumps 224-PCAZ4 and 224-PCAZ8 Universal Air Sampling Pumps 224-PCMA4 and 224-PCMA8 Universal Air Sampling Pumps 224-PCMAZ4 and 224-PCMAZ8
<b>Type of Protection:</b>	Ex ia
<b>Marking Code:</b>	Ex ia I IP55 Ex ia IIC T4 IP55 ANZEx 07.3022X
<b>Manufacturer:</b>	SKC Limited Unit 11 Sunrise Park, Higher Shaftesbury Road Blandford Forum, Dorset, DT11 8ST United Kingdom

#### EQUIPMENT:

The Universal Air Sampling Pumps 224-PCAZ4 and 224-PCAZ8 provide a mechanism by which an amount of pollutant can be determined for a given volume of air.

The air sampling pumps employ a battery operated pump drawing air through a filter mechanism. The pump rotation is calibrated to provide a controlled flow rate and the duration of the sample period is monitored.

The components comprise of a motor with pump and filter attachment, a detachable potted NiCad battery pack (containing current limiting components and a charging socket) and a potted printed electronic circuit. The sampling pumps have LCD displays and are also programmable. The circuitry is mounted within a plastic enclosure.

#### CONDITIONS OF CERTIFICATION:

1. It is a condition of safe use that the battery shall only be charged in safe area with a charger that provides a maximum voltage  $U_m = 8.4$  V.
2. It is a condition of safe use that a static hazard warning label shall be fitted on the apparatus when used for

Group LLC  
bhpbilliton

	<i>This document is valid 24hrs from time printed</i>	
	Document ID: APNRAxxxx      Version: 1.0 Last Review Date: 23/02/11	Page 3 of 16

## 1.1 Purpose

To allow for improved accuracy and understanding of dust levels in various locations in the Longwall at Appin Mine that will lead to improvements for the Longwall mining industry.

## 1.2 Objectives and Scope

The objectives of the risk assessment process were as follows:

- Develop a safe method to allow the temporary installation of Universal Air Sampling Pumps on the Shearer while the machine is producing coal that will not cause damage to Exia equipment in service that will create a reportable incident to the inspectorate.

### What is a benchmark dust testing methodology?

A benchmark dust test measures the *dust loads* produced at independent sources of dust generation presented as a mg/tonne of coal produced.

Once this benchmark is established, installed controls can be measured to quantify how much respirable and inhalable dust they actually remove.

### How does this methodology differ from the Statutory testing process?

The current Statutory testing process measures *exposure levels* of employees usually over the period of a shift. This is presented as mg/m<sup>3</sup> and relates to the amount of respirable and inhalable dust an employee is exposed to in the natural course of his employment.

### What are the limitations of the current testing regime?

Current statutory testing gives either a pass or fail of the employee exposure level to the standards as described in AS2985 (2.5 mg/m<sup>3</sup>) for respirable dust and AS3640 (10 mg/m<sup>3</sup>) for inhalable dust. This is in the form of the 5 samples taken.

This gives a snapshot of the dust that these persons are exposed to over the duration of a mining shift;

This does not give mine operators any indication of where dust is produced on the longwall; It also fails to identify how much dust is produced at each source of dust generation;

Finally it does not identify how efficient the installed controls are at mitigating produced dust.



	<i>This document is valid 24hrs from time printed</i>	
	Document ID: APNRAxxxx      Version: 1.0 Last Review Date: 23/02/11	Page 4 of 16

## APPENDIX

### Why establish a benchmark dust production?

For any operating longwall there is a need to understand the behaviour and characteristics of produced dust during the cutting cycle.

This need has increasingly climbed the list of WHS priorities for mine management, employees, contractors and all other mine personnel.

Dust management is becoming increasingly important as all underground personnel could potentially be exposed to life threatening dust disease or explosions in the underground coal mining environment.

The current statutory testing regime only identifies the exposure levels of personnel on an operating face measured as a time weighted average.

This only gives a snapshot of the dust that personnel are exposed to over the duration of a mining shift.

This does not give mine operators any indication of where dust is produced on the longwall. It also fails to identify how much dust is produced

Nor does it identify how efficient the installed controls are at mitigating produced dust.

### How is the benchmark established?

The dust collection process on a longwall is arranged so that there is a collection of respirable and inhalable dust at each independent source of dust generation.

In each location, separate monitors and heads will be used to sample both respirable and inhalable dust loads.

### What is the testing procedure?

Pumps and heads are placed in the sampling positions at the commencement of the shift.

The pumps and heads used are gravimetric heads for respirable and inhalable dust monitoring currently used for Statutory testing.



	<i>This document is valid 24hrs from time printed</i>	
	Document ID: APNRAxxxx      Version: 1.0 Last Review Date: 23/02/11	Page 5 of 16

# APPENDIX

## Risk Assessment Universal Air Sampling Pump Mounted On Shearer For Testing Inhalable Dust

### A. THE UNIVERSAL PUMP

- |                                  |                                   |                                    |
|----------------------------------|-----------------------------------|------------------------------------|
| 1. LCD Display                   | 10. ON/OFF Switch                 | 19. Low Flow Mode Screw Cover      |
| 2. Flow and Battery Check Button | 11. Accessory Mounting Screws     | 20. Battery Pack                   |
| 3. Start/Hold Button             | 12. Built in Flow Indicator       | 21. Cover over Regulator           |
| 4. Set-Up Button                 | 13. Filter Housing Screws (4 off) | 22. Belt Clip                      |
| 5. Mode Button                   | 14. Filter O Ring Seal            | 23. Main Case Screws (4 off)       |
| 6. Select Button                 | 15. Protection Filter             | 24. Charging Jack                  |
| 7. Set Button                    | 16. Protection Filter Housing     | 25. Battery Pack Screws (2 off)    |
| 8. Flow Adjust Control Screw     | 17. Air Inlet                     | 26. Compensation Adjustment Covers |
| 9. Cover Retaining Screw         | 18. Exhaust Port Cover            |                                    |

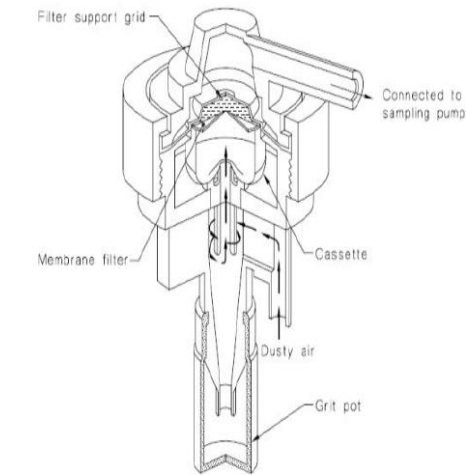
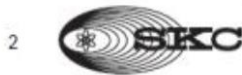
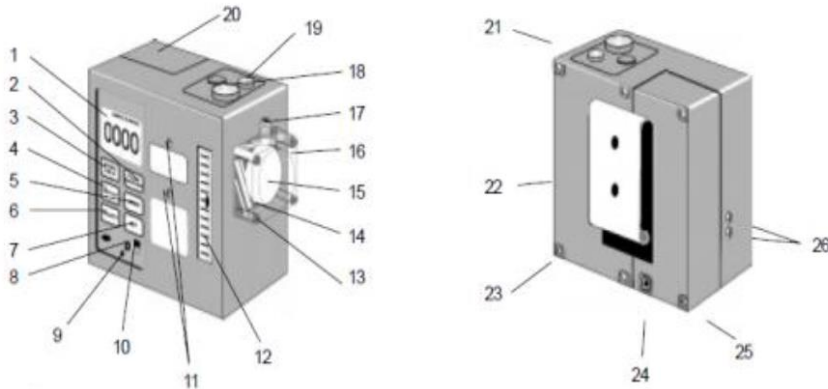


FIGURE 1 ONE TYPE OF SAMPLER WITH CYCLONE ELUTRIATOR

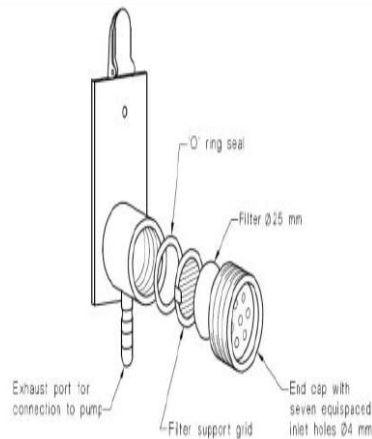


FIGURE 1 MODIFIED UKAEA PERSONAL SAMPLING HEAD USED FOR INHALABLE DUST SAMPLING



<i>This document is valid 24hrs from time printed</i>		Page 6 of 16
Document ID: APNRAxxxx	Version: 1.0	
Last Review Date: 23/02/11		

## 1.3 Definitions

### Hazard

A hazard is the intrinsic potential for an agent, activity or process to lead to an incident, or ongoing condition.

**Environment note:** *The term 'hazard' is essentially equivalent to 'environmental aspect'.*

### Incident (or ongoing condition)

An incident (or ongoing condition) is any occurrence that has the potential to result in adverse consequences to people, the environment, property/plant, or a combination of these.

### Consequence

Consequences can result from the development of an incident over time (immediately after or over an extended period). The concept of consequence includes, within its scope, the potential adverse impacts/effects on people, the environment, plant or property, or a combination of these.

### Impact/Effect

Impacts are specific adverse effects resulting from an incident and may be related to people, the environment, plant or property, or a combination of these.

### Likelihood

Likelihood is the qualitative description of probability and/or frequency in relation to the chance that something will occur. Within this guideline the likelihood term is used in qualitative risk assessments.

### Probability

Probability is a mathematical expression of the chance of a particular outcome. By definition, probability must be expressed as a number between 0 and 1 or converted to a percentage. Within this guideline the probability term is used in quantitative risk assessments.

### Frequency

Frequency is defined as the number of times something (eg, an activity, the hazard or incident) may occur within a specified timeframe, such as daily, weekly or annually. Within this guideline the frequency term is used in quantitative risk assessments.

### Risk

Risk is defined as the likelihood of an impact on people, the environment, property, or a combination of these.

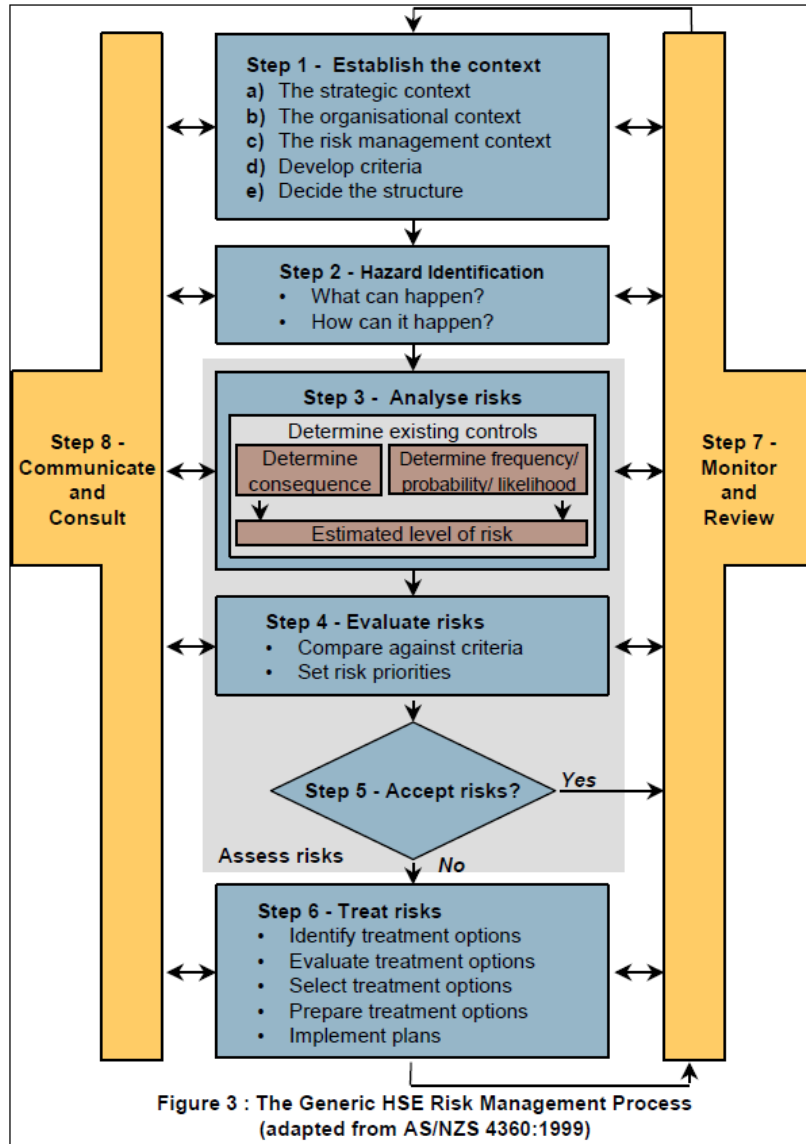


	<i>This document is valid 24hrs from time printed</i>	
	Document ID: APNRAxxxx      Version: 1.0 Last Review Date: 23/02/11	Page 7 of 16



1.4 Risk Management Process Steps

This diagram shows the common steps for the HSE risk management process and is based on the AS/NZS 4360:1999. These steps are explained in the text that follows.



This document is valid 24hrs from time printed		Page 8 of 16
Document ID: APNRAxxxx	Version: 1.0	
Last Review Date: 23/02/11		

### 1.5 BHP HSE Consequence Severity Ranking Table

Severity factor: Considering the risk event being analysed, choose a description that best fits the expected degree of gain, harm, injury, or loss from the most severe impact associated with that risk event, assuming reasonable effectiveness of existing and tested mitigating controls. Where there is more than one impact type possible, look across the table and choose the highest level and corresponding severity factor

Severity level	Impact types	Health and safety	Environment	Social and cultural	Reputation	Legal	Financial	Severity factor
7	>50 fatalities. Very serious irreversible injury to >500 persons.	Unplanned permanent environmental impact over extensive area. Permanent loss of ecosystem or extinction of species.	Complete breakdown of social order. Widespread desecration of items of global cultural significance. Company directly responsible or complicit in severe, and widespread long term impacts on human rights.	Prolonged (>2 months) international multi-NGO and media condemnation. BHPB direct action (includes partner/contractor action) results in reputation issue. Large violent protest (>100 people) resulting in fatal injuries.	Hostile takeover, public shareholder discontent resulting in loss of Chairman/CEO/Board, bankruptcy, closure of operations on multiple sites or BHP Billiton.	>US\$2.5 billion	1000	
6	>20 fatalities. Very serious irreversible injury to >100 persons.	Unplanned severe impact (>20 years) on ecosystem or Threatened Species.	A breakdown of social order. Widespread damage to items of global cultural significance. Highly offensive infringements of cultural heritage. Company directly responsible or complicit in severe, long-term impacts on human rights	International multi-NGO and media condemnation. BHPB direct action (includes partner/contractor action) results in reputation issue. Large violent protest (>100 people) resulting in fatal injuries.	Lack of valid operating title, forced closure of an operation, Anti-trust or Foreign Corrupt Practices inquiry.	US\$250 million – US\$2.5 billion	300	
5	2 -20 fatalities. Short or long term health exposures leading to significant irreversible human health effects to >50 persons.	Unplanned serious or extensive impact (<20 years) on ecosystem or Threatened Species.	Extensive long-term social impacts. Widespread damage to structures/items/ locations of national cultural significance. Serious infringements of cultural heritage. Company directly responsible or complicit in multiple aggravated impacts on human rights.	Serious public or national media outcry (international coverage). Damaging NGO campaign. BHP Billiton reputation severely tarnished. Third party actions (where BHPB is one of many in a group) result in reputation impact. Large protest (>100 people) with significant violence & serious, multiple injuries	Fines and prosecutions relating to criminal breaches including jail terms and being the subject of a royal commission.	US\$50 million – US\$250 million	100	
4	Single fatality. Severe irreversible disability or impairment (>30% of body) to one or more persons.	Unplanned major impact (<5 years) on ecosystem or Threatened Species.	Major long-term social impacts or on-going social issues. Damage to structures/ items of national cultural significance. Major infringement and disregard of cultural heritage. Company directly responsible or complicit in major human rights impacts.	Major adverse national media/public/ NGO attention. 20- 100 people protest, people restrained with force, arrests and injuries. Asser/CSG reputation majority impacted.	Major civil litigation including class actions.	US\$5million – US\$50 million	30	
3	Moderate irreversible disability or impairment (<30% of body) to one or more persons.	Unplanned moderate impact (< 1 year) to ecosystem or non-threatened species.	Moderate medium-term social impacts or frequent social issues. Moderate damage to structures/ items of local cultural significance. Moderate infringement of cultural heritage/ sacred locations. Moderate, temporary human rights impacts.	Attention from regional media and/or heightened concern by local community. Criticism by community, NGOs or activists. Asset reputation adversely affected.	Breach of regulation. Lack of valid exploration title.	US\$500,000 – US\$5 million	10	



This document is valid 24hrs from time printed

Document ID: APNRAxxxx  
Last Review Date: 23/02/11

Version: 1.0

Page 9 of 16

**Risk Assessment**  
**Universal Air Sampling Pump Mounted On Shearer For Testing Inhalable Dust**

2	Objective but reversible disability/impairment Medical treatment injury.	Unplanned minor impact (< 3 months) to non-threatened species or their habitat.	Minor medium-term social impacts on small number of people. Minor repairable damage or disturbance to property, structures, or items. Minor infringement of cultural heritage. Minor, temporary/human rights impacts.	Adverse local public or media attention and complaints. Heightened scrutiny from regulator. Asset reputation is adversely affected with a small number of people.	Minor legal issues, non-compliances and breaches of regulation.	US\$50,000 – US\$ 500,000	3
1	Low level short-term subjective inconvenience or symptoms. No medical treatment.	Unplanned low level environmental impact	Low-level social impacts. Low-level infringement of cultural heritage or minimal disturbance to heritage structures. Minimal impact on human rights.	Public concern restricted to local complaints. Low level interest from local media and/or regulator.	Low-level legal issue.	<US\$50,000	1



<i>This document is valid 24hrs from time printed</i>		Page 10 of 16
Document ID: APNRAxxxx	Version: 1.0	
Last Review Date: 23/02/11		

## APPENDIX

Risk Assessment  
Universal Air Sampling Pump Mounted On Shearer For Testing Inhalable Dust

### 1.6 Likelihood Ranking Table

Operations Given the site, BHP Billiton and industry experience, it:	Uncertainty description	Projects Based on BHP Billiton and industry experience with similar studies or projects, the risk event:	Likelihood factor
could be incurred more than once in a year	Almost certain	could be expected to occur more than once during the study or project delivery	10
could be incurred over a one to two year budget period	Likely	could easily be incurred and has generally occurred in similar studies or projects	3
could be incurred within a five year strategic planning period	Possible	incurred in a minority of similar studies or projects	1
could be incurred within a five to ten year time frame	Unlikely	known to happen, but only rarely	0.3
could be incurred in a 20 to 30 year timeframe	Rare	Has not occurred in similar studies or projects, but could	0.1
<p><i>For a system failure:</i> This consequence has not happened in the industry in the last 50 years.</p> <p><i>For a natural hazard:</i> The predicted return period for a <b>risk event</b> of this strength/magnitude is one in 100 years or longer.</p>	Very rare	conceivable, but only in extreme circumstances	0.03



<i>This document is valid 24hrs from time printed</i>		Page 11 of 16
Document ID: APNRAxxx	Version: 1.0	
Last Review Date: 23/02/11		

## APPENDIX

### Risk Assessment Universal Air Sampling Pump Mounted On Shearer For Testing Inhalable Dust

#### 1.7 Risk Matrix

Likelihood or Frequency / Probability	Consequence Severity				
	Low	Minor	Moderate	Major	Critical
Almost Certain	High	High	Extreme	Extreme	Extreme
Likely	Moderate	High	High	Extreme	Extreme
Possible	Low	Moderate	High	Extreme	Extreme
Unlikely	Low	Low	Moderate	High	Extreme
Rare	Low	Low	Moderate	High	High

#### 2. KEY ASSUMPTIONS

- The plant does not produce incendive arcs in normal operation.
- The plant is suitable for the work environment.
- The installation of the units onto the shearer will be controlled by the Longwall Deputy on shift.

#### 3. RISK ASSESSMENT TEAM

The risk assessment was conducted by inspecting the equipment and reviewing the hazards presented in its intended mode of use. The controls used for similar equipment were utilised where appropriate.

The people involved in the assessment are summarised in the following table.

<i>Name</i>	<i>Role and Qualifications</i>	<i>Location</i>
Alex Sakun	31 years in underground coal	Illawarra Coal
Tim Smith	12 years in underground coal, Deputies qualifications	Illawarra Coal
Brian Plush	Masters Degree	Envirocon Consultant

bhpbilliton


<i>This document is valid 24hrs from time printed</i>		Page 12 of 16
Document ID: APNRxxxx	Version: 1.0	
Last Review Date: 23/02/11		

#### 4. RISK TABLE

HAZARDS	POTENTIAL INCIDENT	POTENTIAL CAUSE	CONTROL MEASURES	CONSEQUENCE	PROBABILITY	RISK	PROPOSED RISK REDUCTIONS	Residual Risk	Accept
1.0 Flammable Gas.	Ignition of gas resulting in injury to one or more people.	Presence of flammable gas in the explosive range & failure or malfunction of the equipment or Damaged equipment.	Management Plans Equipment is Exia  The temporary installation of the dust sampling devices will be conducted under the supervision of the LW shift deputy to ensure security.	Moderate	Rare	Moderate	Risk assessment to be verified by Manager Electrical Engineering.  Trained and authorised personnel in Lamp cabin inspect all equipment to allow sign out of device to take underground.	ALARP (Moderate)	
1.1 Flammable Gas.	Ignition of gas resulting in injury to one or more people.	Presence of flammable gas in the explosive range & Batteries removed in the hazardous zone.	Mine inspection system requires power off in hazardous zone at 1.25% CH <sub>4</sub> and men withdrawn at 2% CH <sub>4</sub> . Standard Of Engineering Practice for Portable Electric Apparatus does not allow for removal of battery in the mine. Mine inspection system.	Moderate	Rare	Moderate	See 1.0	ALARP (Moderate)	
1.2 Flammable Gas.	Ignition of gas resulting in injury	Sudden contamination of	Mine inspection system.	Moderate	Rare	Moderate	See 1.0	ALARP (Moderate)	

<i>This document is valid 24hrs from time printed</i>	
Document ID: APNRAxxxx	Version: 1.0
Last Review Date: 23/02/11	Page 13 of 16

Risk Assessment  
 Universal Air Sampling Pump Mounted On Shearer For Testing Inhalable Dust

HAZARDS	POTENTIAL INCIDENT	POTENTIAL CAUSE	CONTROL MEASURES	CONSEQUENCE	PROBABILITY	RISK	PROPOSED RISK REDUCTIONS	Residual Risk	Accept
2.0 Equipment sparking.	Ignition of gas resulting in injury to one or more people.	Damage to equipment. Electrical failure.	Mine inspection system. Environmental monitoring. Equipment is rated as Exia and is allowed to take into a hazardous zone. Equipment will be signed into mine as per Management Plan. The temporary installation of the dust sampling devices will be conducted under the supervision of the LW shift deputy to ensure security.	Moderate	Rare	Moderate	See 1.0	ALARP (Moderate)	
3.0 Overheating of equipment	Ignition of gas resulting in injury to one or more people.	Battery failure. Malfunction of equipment.	Equipment is rated as Exia Equipment is robust and shockproof in construction and designed as fit for purpose.	Moderate	Rare	Moderate		ALARP (Moderate)	
4.0 Loss Of Equipment 	Ignition of gas resulting in injury to one or more people.	Battery failure. Malfunction of equipment..	The temporary installation of the dust sampling devices will be	Moderate	Rare	Moderate		ALARP (Moderate)	

<i>This document is valid 24hrs from time printed</i>	
Document ID: APNRAXxxx	Version: 1.0
Last Review Date: 23/02/11	

Risk Assessment  
 Universal Air Sampling Pump Mounted On Shearer For Testing Inhalable Dust

HAZARDS	POTENTIAL INCIDENT	POTENTIAL CAUSE	CONTROL MEASURES	CONSEQUENCE	PROBABILITY	RISK	PROPOSED RISK REDUCTIONS	Residual Risk	Accept
5.0 Electricity	Electric Shock. Burns.	Malfunction of equipment. Equipment run over by machinery UG.	conducted under the supervision of the LW shift deputy to ensure security. Mine inspection system. Environmental monitoring. Equipment is rated as Exia and is allowed to take into a hazardous zone. Equipment will be signed into mine as per Management Plan. The temporary installation of the dust sampling devices will be conducted under the supervision of the LW shift deputy to ensure security.	Low	Rare	Low		Low	



<i>This document is valid 24hrs from time printed</i>		Page 15 of 16
Document ID : APNRAxxxx	Version: 1.0	
Last Review Date: 23/02/11		



**5. RISK REDUCTION VERIFICATION FORM**

**Risk Reduction Verification Form**

Risk Reference No.	Risk Reduction Measure	Verification of Completed Action	Date Required	Sign off by Responsible Officer	Date Completed
1.0	This risk assessment to be verified by Manager. Of Electrical Engineering	A.Sakun	March 2012		
1.0	Include copy of this risk assessment in the minutes for the OH&S committee.	A.Sakun	April 2012		

<b>Nathan England</b>		<b>23<sup>rd</sup> March 2012</b>
Manager Electrical Engineering	Signature	Date



<i>This document is valid 24hrs from time printed</i>		Page 16 of 16
Document ID : APNRAxxxx	Version: 1.0	
Last Review Date: 23/02/11		

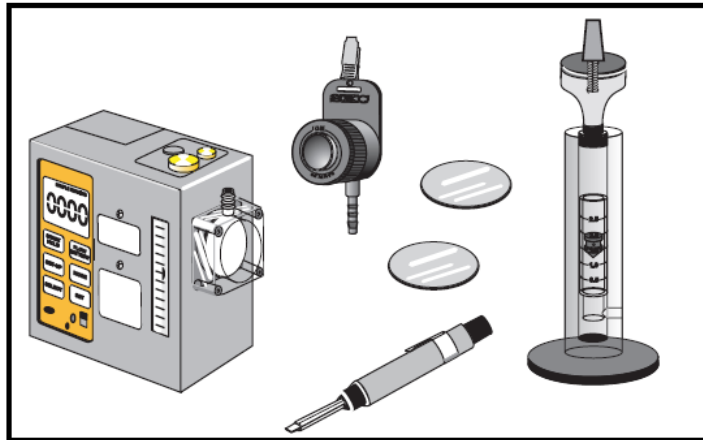
Appendix 6 – Inhalable Dust Pump Calibration

**C. INHALABLE DUST SAMPLING USING THE I.O.M.**

*Inhalable dust is taken to mean any solid particle which by its small size can be carried in an airflow or remains airborne. It does include respirable dust.*

**You will need :-**

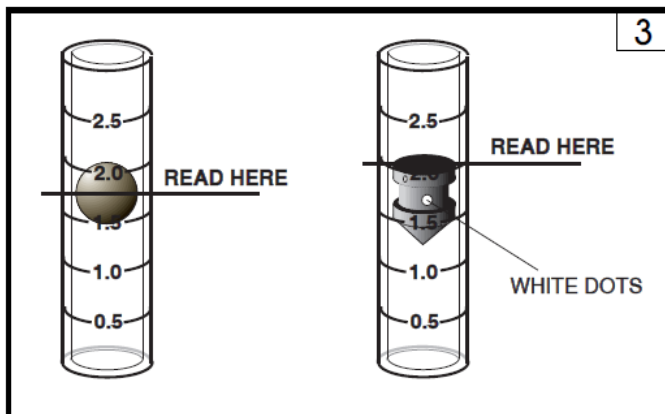
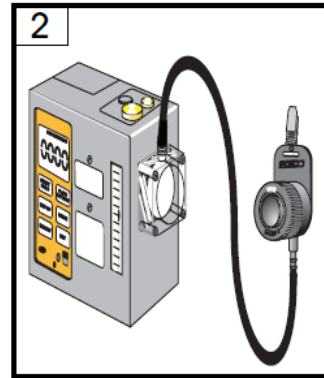
- Sampling pump (fully charged)
- I O M sampling head
- Connecting tube
- Filter paper and pre-weighed filter paper from the same box or batch
- Rotameter or other calibration device capable of measuring 2 litres per minute
- Toolkit to adjust flow



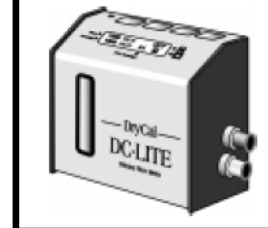
1. Using a cassette with a filter paper that is not pre-weighed, mount it into the I O M Cassette. Place the cassette into the sampler body and screw on the front cover.

2. Connect the I O M head with cassette in it to the inlet of the sampling pump using plastic tube supplied. The inlet pipe stub on the Universal can be found pointing upwards from the clear plastic cover on the right hand side of the pump. The filter contained inside this cover is not of concern for sampling and only acts as a protection device for the pump internals.

3. Using a rotameter to set the flow. A rotameter is a graduated glass tube with a float or ball inside it contained in or on some kind of stand. There are two types of float used in rotameters. To read them correctly depends on which type you have. If the type you have has a ball inside the tube you must read the flow from the centre of the ball. If it is the float type readings are taken from the TOP surface. Please refer to sketch opposite. The float type usually has 3 white dots on the float. These dots are to show the float is spinning in the airflow and gives a visual indication that it is not touching the walls of the tube which would affect the accuracy of the reading.

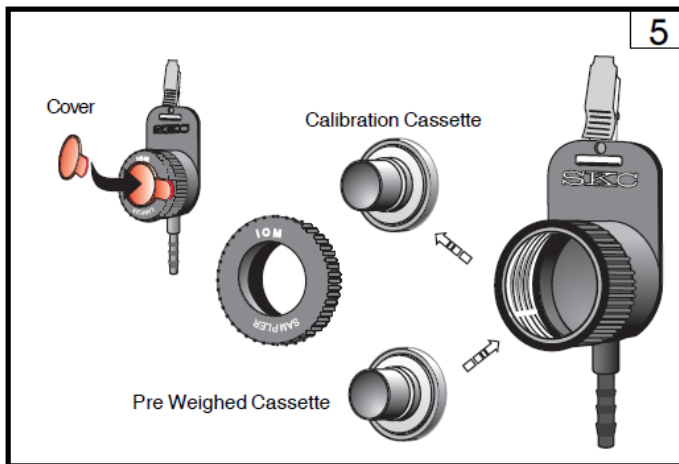
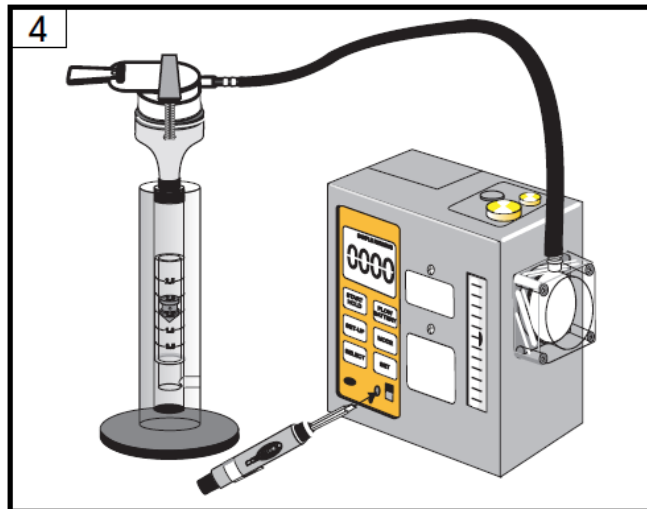


NOTE: MDHS 14 states that a primary standard such as the DC Lite should be used for flow calibration in favour of rotameters.



## INHALABLE DUST

4. The I O M head with filter is clipped down onto the foam seal on top of the rotameter ensuring a good seal with no leaks. With the toolkit the flow is adjusted by turning the flow adjustment screw. This is located to the bottom left side of the universal sampler and marked 'flow adjust'. As the screw is turned the float or ball should move up or down inside the glass tube. If this does not happen, check the system for leaks or blockages. One common cause of lack of flow is the separation papers (coloured BLUE) being used in error. Most filters are white in colour. Once the flow is set to the required level switch the sampler off.

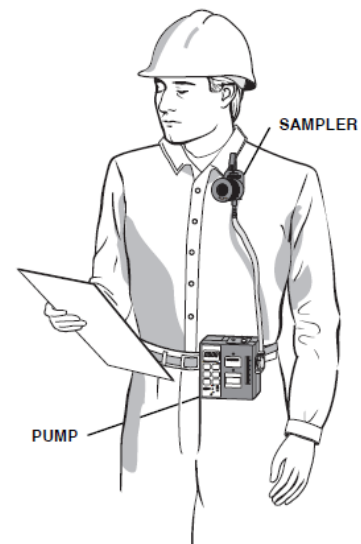


5. Replace the cassette and filter paper assembly with the pre-weighed one. Check the flow once again and do any final adjustments needed to bring the flow to the required level. It is advisable to do this as quickly as possible to minimise the chance of collecting anything which may affect the final result. The I O M head complete with new cassette filter assembly should now be fitted with the cover supplied and is ready to take into the work place.

6. With the cover still in place over the filter head mount the equipment onto the person you wish to sample. The head should be mounted as close to the breathing zone as is practical and comfortable. The pump can be either clipped to a belt or placed into a pouch. NOTE: The connecting pipe can present a hazard if left to flap around in much the same way as a necktie. Measures should be taken to protect the wearer by clipping or restraining the pipe so that it cannot be caught in anything.

Once the pump is mounted to the subject in a satisfactory way remove the cover from the I O M inlet and switch the pump on.

**IMPORTANT:** The start time of the sample should be noted. At the end of the sample switch the pump off, cover the I O M head and note the finish time of the sample. The time, person, flow and relevant details of the sample should be noted down and indexed to the cassette by number or code.



Appendix 7 – Respirable Dust Pump Calibration

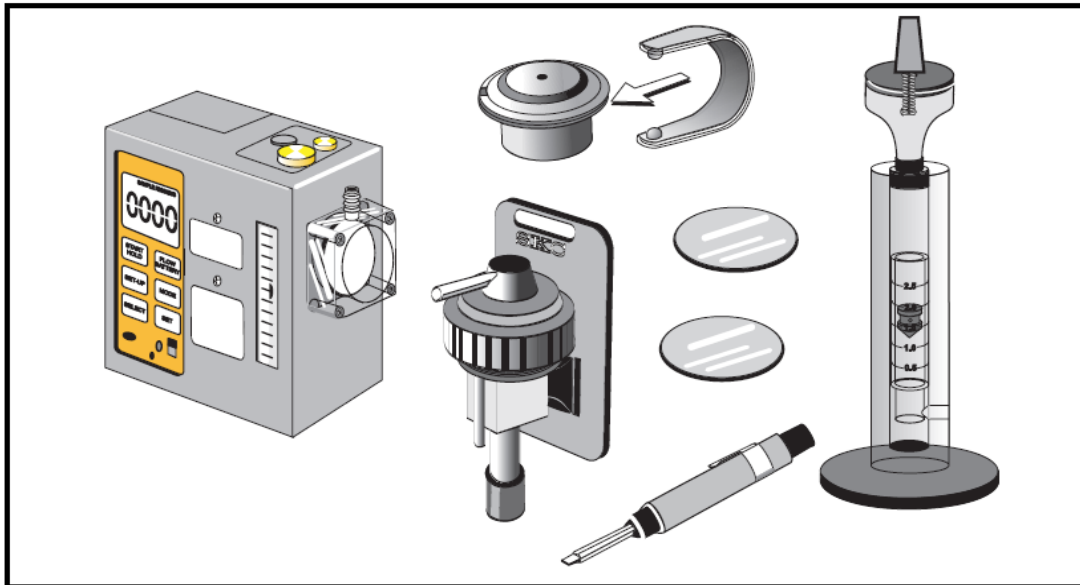
**D. RESPIRABLE DUST SAMPLING USING THE CYCLONE**

Respirable dust is taken to be solid particles of less than 8.5 microns in size. Dust of this small size is normally invisible to the human eye. Respirable dust can get deep into the lung and does not get ejected by the normal means of breathing out, coughing or travelling out

in the lung mucus. It is because of this ability to stay in the body it is considered dangerous.

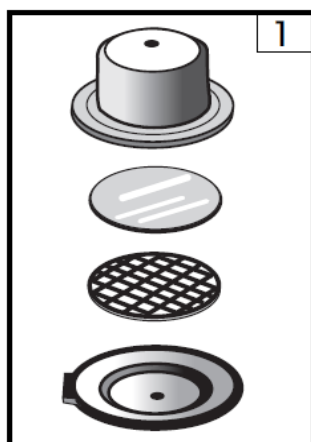
**You will need :-**  
 Sampling pump (fully charged)  
 Clear connecting tube

*Cyclone and cassette*  
 Filter paper and pre-weighed filter paper from the same box or batch  
 Rotameter or other calibration device capable of measuring 2 litres per minute  
 Toolkit to adjust flow



**IF USING A CYCLONE IT SHOULD BE RUN AT 2.2 LITRES PER MINUTE**

**FOR INFORMATION ON USING THE I.O.M. FOR RESPIRABLE, THORACIC AND OTHER DUST FRACTIONS PLEASE CONTACT SKC CUSTOMER CARE ON 44 (0) 1258 480188**

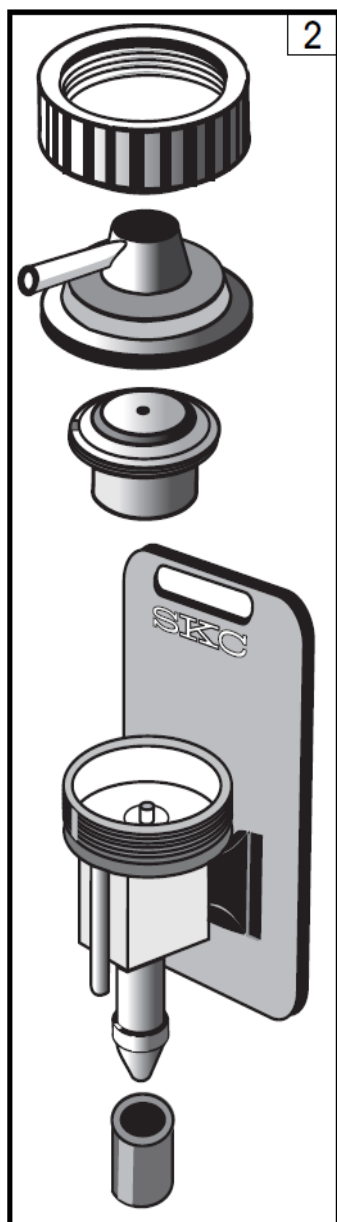


1. Using the filter paper that is not pre-weighed mount it into the cyclone cassette as shown in the sketch. Experience has shown that the easiest way to place the filter in a cassette is as follows. Remove the TOP and place it onto a surface writing down, (so it looks like a shallow bowl). Put the filter support grid into the top and place the filter on the grid. Carefully lift up this assembly and after aligning the slot with the tab on the cassette bottom snap the two halves together. By reassembling the cassette in this way the filter remains located centrally on the grid

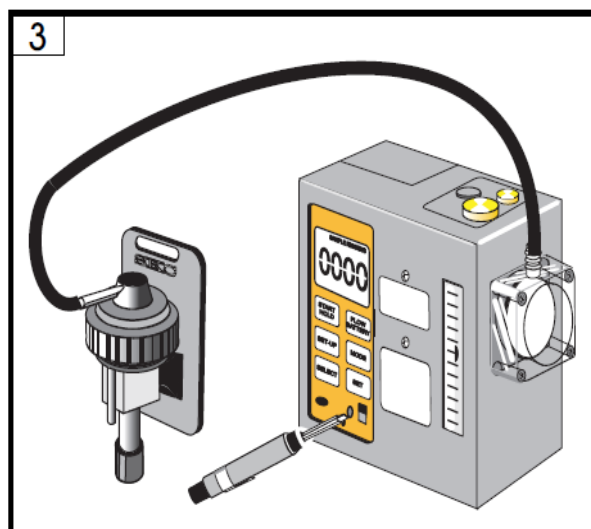


## RESPIRABLE DUST

2. Place the cassette into the cyclone .  
 NOTE: the cassette is mounted in what appears to be an upside down way with the filter paper to the bottom and the support grid above it. Make sure a grit pot is fitted to the bottom of the cyclone.

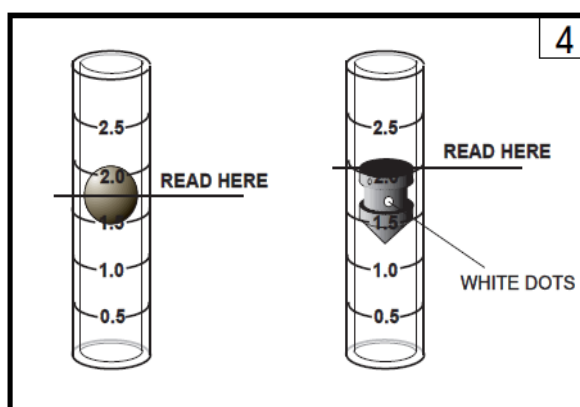


3. Connect the cyclone to the inlet of the sampling pump using plastic tube supplied. The inlet pipe stub on the Universal can be found pointing upwards from the clear plastic cover on the right hand side of the pump. The filter contained inside this cover is not of concern for sampling and only acts as a protection device for the pump internals.



4. To set the flow rate required, in this case 2.2 litres per minute, an external flow calibration device such as a rotameter or DryCal should be used. Make sure they are capable of measuring the required flow. There are two types of float used in rotameters. To read them correctly depends on which type you have. If the type you have has a ball inside the tube you must read the flow

from the centre of the ball. If it is the float type readings are taken from the TOP surface. Please refer to sketch opposite. The float type usually has 3 white dots on the float. These dots are to show the float is spinning in the airflow and gives a visual indication that it is not touching the walls of the tube which would affect the accuracy of the reading.



## RESPIRABLE DUST

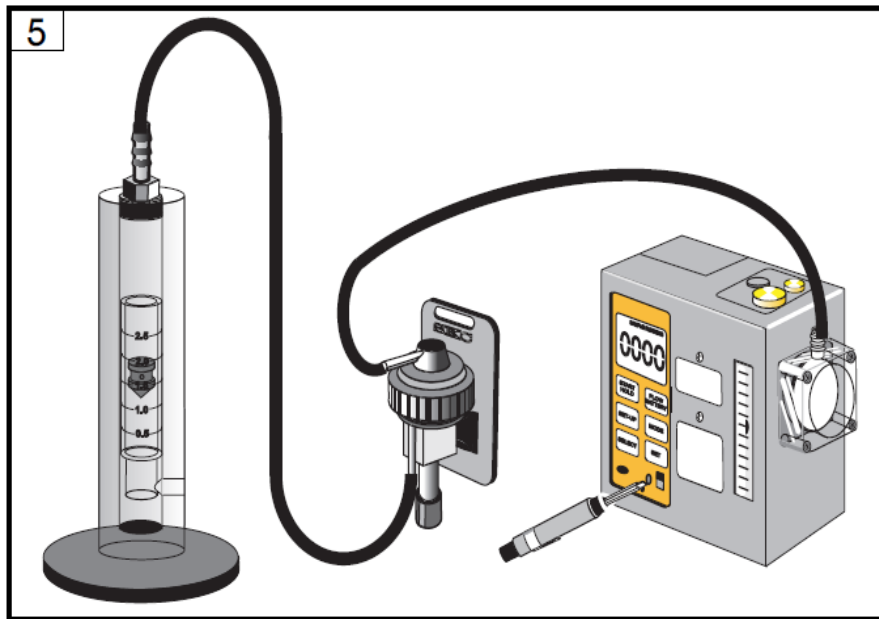
5. Using a rotameter to set the flow. Once the cyclone has been connected to the sampling pump, as in the sketch, there will be a pipe stub pointing downwards from the body.

This is the air inlet pipe. Connect from here to the rotameter using a length of plastic tube. An adapter is required to make the connection to the rotameter. Some rotameters are provided with a

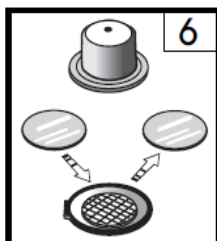
threaded pipe stub which can be screwed into the hole in the middle of the foam seal. The pipe from the cyclone can then be connected to this adapter. With the toolkit the flow is adjusted by turning the flow adjustment screw. This is located to the bottom left side of the universal sampler and marked 'flow adjust'. As the screw is turned the float or ball should move up or down inside the glass tube.

If this does not happen check the system for leaks or blockages.

One common cause of lack of flow is by using the separation papers sometime found in boxes of filters and usually coloured blue instead of the filter themselves which are normally white. Once the flow is set to the required level switch the sampler off.



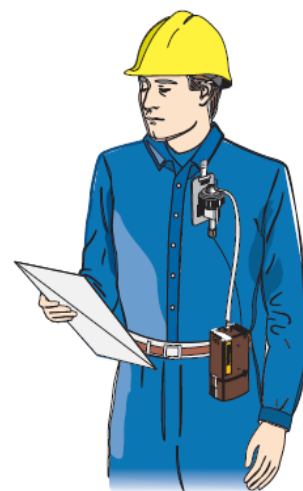
6. Replace the filter in the cyclone cassette with the pre-weighed one and refit the cassette into the cyclone. Check the flow once again with the pre-weighed filter in place and do any final adjustments needed to bring the flow to the required level. It is advisable to do this as quickly as possible to minimise the chance of collecting anything which may affect the final result. The equipment is now ready to take into the work place.



7. Mount the equipment onto the person you wish to sample. The cyclone should be mounted as close to the breathing zone as is practical and comfortable. The pump can be either clipped to a belt or placed into a pouch.

**NOTE:** The connecting pipe can present a hazard if left to flap around in much the same way as a necktie. Measures should be taken to protect the wearer by clipping or restraining the pipe so that it cannot be caught in anything. Once the pump is mounted to the subject in a satisfactory way it can be switched on. **IMPORTANT:** The start time should be noted down.

At the end of the sample switch the pump off and note the finish time. The time, person, flow and relevant details of the sample should be noted down and indexed to the filter paper by number or code.



Appendix 8 – Mine A Results From Coal Services



Coal Services Pty Limited

ABN 98 099 078 234

Occupational Health Services for Industry

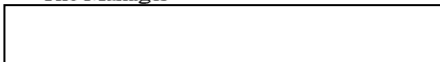
Statistical Services

Training and Mines Rescue Procedures

Workers' Compensation Insurance for the NSW Coal Industry

SINGLETON  
18<sup>th</sup> October 2010

The Manager



**'SPECIAL' GRAVIMETRIC AIRBORNE INHALABLE & RESPIRABLE STATIC  
DUST SAMPLE – TEST NO. 1**

Dear Sir

Please find enclosed results of a 'Special' airborne static inhalable and respirable dust sample taken at your Colliery on the 9<sup>th</sup> October 2010 by our Occupational Hygiene Technician.

There are two respirable, eleven static respirable, and eleven static inhalable samples.

**The Standing Committee on Dust Research and Control suggests a copy of these results be displayed on the colliery notice board.**

Yours faithfully

Gary Mace  
Manager - Occupational Hygiene Services

Copies to: File

Level 21/44 Market Street  
Sydney NSW 2000  
GPO Box 3842  
Sydney NSW 2001  
Phone: 02 8270 3200  
Fax: 02 9262 6090  
DX 13017 Sydney West

558-580 Princes Highway  
Woonona NSW 2517  
PO Box 42  
Corrimal NSW 2518  
Phone: 02 4286 5400  
Fax: 02 4285 4144  
DX 5253 Wollongong

3 Proto Avenue  
PO Box 72  
Lithgow NSW 2790  
Phone: 02 6350 1050  
Fax: 02 6351 2407

1 Civic Avenue  
PO Box 317  
Singleton NSW 2330  
Phone: 02 6571 9900  
Fax: 02 6572 2667  
DX 7068 Singleton

143 Main Road  
Speers Point NSW 2284  
PO Box 101  
Basiliano NSW 2284  
Phone: 02 4948 3100  
Fax: 02 4953 0541  
DX 7801 Newcastle



**GRAVIMETRIC  
AIRBORNE DUST  
SAMPLING REPORT**

**UNDERGROUND - LONGWALL**



NATA Accredited Laboratory  
Number : 10781  
This document is issued in accordance  
with NATA's accreditation requirements.

**SPECIAL**

Test no. **S 262/10**  
Mine   
Test date   
Seam **LIDDELL**  
Location of tests **LW 10**  
Material being worked **COAL/STONE FLOOR & ROOF**  
General nature of work **LONGWALL RETREAT (UNI-DI)**  
Machine used **EICKHOFF D.E.R.D.S.**  
Machine info

Sprays	Drum	Venturi	Other	84	Not operating	7
	Clearer					
	Shearer					
	Loader					
	Crusher					

Seam thickness (m)  
*(if less than mining height)*  
Mining height (m) **2.60**  
Drum Diameter (m) **2.00**  
Drum Rpm Main (m) **42**

Other dust suppression methods

**RESPIRABLE DUST REPORT**

Time Started **09.35 hrs** Finished **13.50 hrs** Estimated production (Tonnes) **2000**

Filter no	Name	Occupation	Respirator	Beard	Result (mg/m <sup>3</sup> )	Alpha-Quartz (mg/m <sup>3</sup> )
106364	BILL LANG	SHEARER OPERATOR T/G	P1	-	1.3	-
106365	MARK FRASER	SHEARER OPERATOR M/G	AIR HELMET	-	1.6	-

THESE SAMPLES WERE TAKEN AND ANALYSED IN ACCORDANCE WITH AS2986 AND THE NSW COAL MINES HEALTH AND SAFETY REGULATION 2006.

**Specified Limits:** Respirable Dust 2.5 mg/m<sup>3</sup>, Quartz-Containing Dust 0.12 mg/m<sup>3</sup>

**Remarks** TEST NO. 1 WAS CONDUCTED WITH ALL DUST SUPPRESSION SYSTEMS TURNED OFF EXCEPT FOR SHEARER DRUM SPRAYS. ALL SAMPLES TAKEN WERE STATIC EXCEPT FOR SHEARER OPERATORS M/G AND T/G. TEST UNDERTAKEN UNDER NORMAL PRODUCTION SEQUENCES WITH OPERATORS STILL OPERATING SUPPORTS AT T/G MANUALLY. VARIOUS DELAYS OCCURRED DURING SAMPLING PERIOD INCLUDING BELTS, SHEARER ELECTRICAL, SHEAR PINS ETC.

Sampled by **Stephen Holmes** Weighed by **Stephen Holmes**  
533 Lake Road Argenton Laboratory  
Issued Date **18/Oct/2010** Approved signatory **Gary Mace (Manager - Occupational Hygiene Services)**

**VENTILATION INFORMATION**

Ventilation type	Maingate	No 8 Chock	Midface	-	Tailgate
Air Velocity (m/s)	0.0	0.0	0.0	0.0	0.0
Quantity (m <sup>3</sup> /s)	0.0	0.0	0.0	0.0	0.0

*Ventilation readings are approximate only and are not covered by this laboratory's scope of accreditation.*

**Comments** Test No. 1 - All dust suppression turned off.





**GRAVIMETRIC  
AIRBORNE DUST  
SAMPLING REPORT**

**UNDERGROUND - LONGWALL**



NATA Accredited Laboratory  
Number : 10781  
This document is issued in accordance  
with NATA's accreditation requirements.

**SPECIAL**

Test no. **S 262/10**  
 Mine   
 Test date   
 Seam **LIDDELL**  
 Location of tests **LW 10**  
 Material being worked **COAL/STONE FLOOR & ROOF**  
 General nature of work **LONGWALL RETREAT (UNI-DI)**  
 Machine used **EICKHOFF D.E.R.D.S.**  
 Machine info

Sprays	Drum	Venturi	Other	84	Not operating	7
Clearer						
Shearer						
Loader						
Crusher						

Seam thickness (m)  
*(if less than mining height)*  
 Mining height (m) **2.60**  
 Drum Diameter (m) **2.00**  
 Drum Rpm Main (m) **42**

Other dust suppression methods

**RESPIRABLE DUST REPORT**

Time Started **09.35 hrs** Finished **13.50 hrs** Estimated production (Tonnes) **2000**

Filter No	Location/Comments	Respirator	Beard	Result (mg/m <sup>3</sup> )	Alpha-Quartz (mg/m <sup>3</sup> )
106359	13 C/T LW 10	STATIC SAMPLE	-	0.3	-
106360	BELT RD 13 C/T LW 10	STATIC SAMPLE	-	0.4	-
106361	BSL	STATIC SAMPLE	-	0.6	-
106362	HRS NO. 1 #	STATIC SAMPLE	-	0.7	-
106363	HRS NO. 5 #	STATIC SAMPLE	-	0.9	-

**Remarks** TEST NO. 1 WAS CONDUCTED WITH ALL DUST SUPPRESSION SYSTEMS TURNED OFF EXCEPT FOR SHEARER DRUM SPRAYS. ALL SAMPLES TAKEN WERE STATIC EXCEPT FOR SHEARER OPERATORS M/G AND T/G. TEST UNDERTAKEN UNDER NORMAL PRODUCTION SEQUENCES WITH OPERATORS STILL OPERATING SUPPORTS AT T/G MANUALLY. VARIOUS DELAYS OCCURRED DURING SAMPLING PERIOD INCLUDING BELTS, SHEARER ELECTRICAL, SHEAR PINS ETC.

Sampled by **Stephen Holmes** Weighed by **Stephen Holmes**  
 533 Lake Road Argenton Laboratory  
 Issued Date **18/Oct/2010** Approved signatory **Gary Mace (Manager, Occupational Hygiene Services)**

**VENTILATION INFORMATION**

Ventilation type	Maingate	No 8 Chock	Midface	-	Tailgate
Air Velocity (m/s)	0.0	0.0		0.0	0.0
Quantity (m <sup>3</sup> /s)	0.0	0.0	0.0	0.0	0.0

*Ventilation readings are approximate only and are not covered by this laboratory's terms of accreditation.*

**Comments** **Test No. 1 - All dust suppression turned off.**



**GRAVIMETRIC  
AIRBORNE DUST  
SAMPLING REPORT**

**UNDERGROUND - LONGWALL**



NATA Accredited Laboratory  
Number : 10781  
This document is issued in accordance  
with NATA's accreditation requirements.

**SPECIAL**

Test no. **S 262/10**  
 Mine   
 Test date   
 Seam **LIDDELL**  
 Location of tests **LW 10**  
 Material being worked **COAL/STONE FLOOR & ROOF**  
 General nature of work **LONGWALL RETREAT (UNI-DI)**  
 Machine used **EICKHOFF D.E.R.D.S.**  
 Machine info

Sprays	Drum	Venturi	Other	84	Not operating	7
Clearer						
Shearer						
Loader						
Crusher						

Seam thickness (m)  
*(if less than mining height)*  
 Mining height (m) **2.60**  
 Drum Diameter (m) **2.00**  
 Drum Rpm Main (m) **42**

Other dust suppression methods

**RESPIRABLE DUST REPORT**

Time Started **09.35 hrs** Finished **13.50 hrs** Estimated production (Tonnes) **2000**

Filter No	Location/Comments	Respirator	Beard	Result (mg/m <sup>3</sup> )	Alpha-Quartz (mg/m <sup>3</sup> )
106366	T/G SUPPORTS	STATIC SAMPLE	-	2.2	-
106367	HRS NO. 65 #	STATIC SAMPLE	-	3.6	-
106368	HRS NO. 45 #	STATIC SAMPLE	-	3.4	-
106369	HRS NO. 105 #	STATIC SAMPLE	-	4.1	-
106370	HRS NO. 85 #	STATIC SAMPLE	-	5.7	-

**Remarks** TEST NO. 1 WAS CONDUCTED WITH ALL DUST SUPPRESSION SYSTEMS TURNED OFF EXCEPT FOR SHEARER DRUM SPRAYS. ALL SAMPLES TAKEN WERE STATIC EXCEPT FOR SHEARER OPERATORS M/G AND T/G. TEST UNDERTAKEN UNDER NORMAL PRODUCTION SEQUENCES WITH OPERATORS STILL OPERATING SUPPORTS AT T/G MANUALLY. VARIOUS DELAYS OCCURRED DURING SAMPLING PERIOD INCLUDING BELTS, SHEARER ELECTRICAL, SHEAR PINS ETC.

Sampled by **Stephen Holmes** Weighed by **Stephen Holmes**  
 533 Lake Road Argenton Laboratory  
 Issued Date **18/Oct/2010** Approved signatory **Gary Mace (Manager, Occupational Hygiene Services)**

**VENTILATION INFORMATION**

Ventilation type

	Maingate	No 8 Chock	Midface	-	Tailgate
Air Velocity (m/s)	0.0	0.0		0.0	0.0
Quantity (m <sup>3</sup> /s)	0.0	0.0	0.0	0.0	0.0

*Ventilation readings are approximate only and are not covered by this laboratory's terms of accreditation.*

**Comments** Test No. 1 - All dust suppression turned off.



**GRAVIMETRIC  
AIRBORNE DUST  
SAMPLING REPORT**

**UNDERGROUND - LONGWALL**



NATA Accredited Laboratory  
Number : 10781  
This document is issued in accordance  
with NATA's accreditation requirements.

**SPECIAL**

Test no. **S 263/10**  
 Mine   
 Test date   
 Seam **LIDDELL**  
 Location of tests **LW 10**  
 Material being worked **COAL/STONE FLOOR & ROOF**  
 General nature of work **LONGWALL RETREAT (UNI-DI)**  
 Machine used **EICKHOFF D.E.R.D.S.**  
 Machine info

Sprays	Drum	Venturi	Other	84	Not operating	7
Clearer				0		0
Shearer				3		0
Loader				2		0
Crusher				16		

Seam thickness (m)  
*(if less than mining height)*  
 Mining height (m) **2.60**  
 Drum Diameter (m) **2.00**  
 Drum Rpm Main (m) **42**

Other dust suppression methods

**RESPIRABLE DUST REPORT**

Time Started **14.40 hrs** Finished **17.10 hrs** Estimated production (Tonnes) **2000**

Filter no	Name	Occupation	Respirator	Beard	Result (mg/m <sup>3</sup> )	Alpha-Quartz (mg/m <sup>3</sup> )
106388	BILL LANG	SHEARER OPERATOR M/G	P1	-	1.6	-
106389	MARK FRASER	SHEARER OPERATOR T/G	AIR HELMET	-	1.7	-

THESE SAMPLES WERE TAKEN AND ANALYSED IN ACCORDANCE WITH AS2985 AND THE NSW COAL MINES HEALTH AND SAFETY REGULATION 2006. Specified Limits: Respirable Dust 2.5 mg/m<sup>3</sup>, Quartz-Containing Dust 0.12 mg/m<sup>3</sup>

Remarks **TEST NO. 2 WAS SAMPLED WITH ALL DUST SUPPRESSION APPLIED - CRUSHER SPRAYS, BSL DELIVERY, AFC SPRAY ARMS X 1.**

Sampled by **Stephen Holmes** Weighed by **Stephen Holmes**  
 533 Lake Road Argenton Laboratory  
 Issued Date **18/Oct/2010** Approved signatory **Gary Mace (Manager - Occupational Hygiene Services)**

**VENTILATION INFORMATION**

Ventilation type	Maingate	No 8 Chock	Midface	-	Tailgate
Air Velocity (m/s)	0.0	0.0		0.0	0.0
Quantity (m <sup>3</sup> /s)	0.0	0.0	0.0	0.0	0.0

*Ventilation readings are approximate only and are not covered by this laboratory's scope of accreditation.*

Comments **See Attached Vent Survey.**



**GRAVIMETRIC  
AIRBORNE DUST  
SAMPLING REPORT**

**UNDERGROUND - LONGWALL**



NATA Accredited Laboratory  
Number : 10781  
This document is issued in accordance  
with NATA's accreditation requirements.

**SPECIAL**

Test no. **S 263/10**  
Mine   
Test date   
Seam **LIDDELL**  
Location of tests **LW 10**  
Material being worked **COAL/STONE FLOOR & ROOF**  
General nature of work **LONGWALL RETREAT (UNI-DI)**  
Machine used **EICKHOFF D.E.R.D.S.**  
Machine info

Sprays	Drum	Venturi	Other	84	Not operating	7
Clearer				0		0
Shearer				3		0
Loader				2		0
Crusher				16		

Seam thickness (m)  
*(if less than mining height)*  
Mining height (m) **2.60**  
Drum Diameter (m) **2.00**  
Drum Rpm Main (m) **42**

Other dust suppression methods

**RESPIRABLE DUST REPORT**

Time Started **14.40 hrs** Finished **17.10 hrs** Estimated production (Tonnes) **2000**

Filter No	Location/Comments	Respirator	Beard	Result (mg/m <sup>3</sup> )	Alpha-Quartz (mg/m <sup>3</sup> )
106383	13 C/T LW 10	STATIC SAMPLE	-	0.4	-
106384	BELT RD 13 C/T LW 10	STATIC SAMPLE	-	0.4	-
106385	BSL	STATIC SAMPLE	-	0.7	-
106386	HRS NO. 1 #	STATIC SAMPLE	-	0.7	-
106387	HRS NO. 5 #	STATIC SAMPLE	-	1.4	-

Remarks **TEST NO. 2 WAS SAMPLED WITH ALL DUST SUPPRESSION APPLIED - CRUSHER SPRAYS, BSL DELIVERY, AFC SPRAY ARMS X 1.**

Sampled by **Stephen Holmes**

Weighed by **Stephen Holmes**  
**533 Lake Road Argenton Laboratory**

Issued Date **18/Oct/2010**

Approved signatory **Gary Mace (Manager - Occupational Hygiene Services)**

**VENTILATION INFORMATION**

Ventilation type

	Maingate	No 8 Chock	Midface	-	Tailgate
Air Velocity (m/s)	0.0	0.0		0.0	0.0
Quantity (m <sup>3</sup> /s)	0.0	0.0	0.0	0.0	0.0

*Ventilation readings are approximate only and are not covered by this laboratory's terms of accreditation.*

Comments **See Attached Vent Survey.**



**GRAVIMETRIC  
AIRBORNE DUST  
SAMPLING REPORT**

**UNDERGROUND - LONGWALL**



NATA Accredited Laboratory  
Number : 10781  
This document is issued in accordance  
with NATA's accreditation requirements.

**SPECIAL**

Test no. **S 263/10**  
 Mine   
 Test date   
 Seam **LIDDELL**  
 Location of tests **LW 10**  
 Material being worked **COAL/STONE FLOOR & ROOF**  
 General nature of work **LONGWALL RETREAT (UNI-DI)**  
 Machine used **EICKHOFF D.E.R.D.S.**  
 Machine info

Sprays	Drum	Venturi	Other	84	Not operating	7
Clearer				0		0
Shearer				3		0
Loader				2		0
Crusher				16		

Seam thickness (m)  
*(if less than mining height)*  
 Mining height (m) **2.60**  
 Drum Diameter (m) **2.00**  
 Drum Rpm Main (m) **42**

Other dust suppression methods

**RESPIRABLE DUST REPORT**

Time Started **14.40 hrs** Finished **17.10 hrs** Estimated production (Tonnes) **2000**

Filter No	Location/Comments		Respirator	Beard	Result (mg/m <sup>3</sup> )	Alpha-Quartz (mg/m <sup>3</sup> )
106390	T/G SUPPORTS	STATIC SAMPLE		-	5.4	-
106391	HRS NO. 65 #	STATIC SAMPLE		-	3.3	-
106392	HRS NO. 45 #	STATIC SAMPLE		-	3.1	-
106393	HRS NO. 105 #	STATIC SAMPLE		-	3.5	-
106394	HRS NO. 85 #	STATIC SAMPLE		-	3.6	-

Remarks **TEST NO. 2 WAS SAMPLED WITH ALL DUST SUPPRESSION APPLIED - CRUSHER SPRAYS, BSL DELIVERY, AFC SPRAY ARMS X 1.**

Sampled by **Stephen Holmes** Weighed by **Stephen Holmes**  
 533 Lake Road Argenton Laboratory  
 Issued Date **18/Oct/2010** Approved signatory **Gary Mace (Manager - Occupational Hygiene Services)**

**VENTILATION INFORMATION**

Ventilation type

	Maingate	No 8 Chock	Midface	-	Tailgate
Air Velocity (m/s)	0.0	0.0		0.0	0.0
Quantity (m <sup>3</sup> /s)	0.0	0.0	0.0	0.0	0.0

*Ventilation readings are approximate only and are not covered by this laboratory's terms of accreditation.*

Comments **See Attached Vent Survey.**



**GRAVIMETRIC  
AIRBORNE DUST  
SAMPLING REPORT**

**UNDERGROUND - LONGWALL**



NATA Accredited Laboratory  
Number : 10781  
This document is issued in accordance  
with NATA's accreditation requirements.

**SPECIAL**

Test no. **S 262/10**  
 Mine   
 Test date   
 Seam **LIDDELL**  
 Location of tests **LW 10**  
 Material being worked **COAL/STONE FLOOR & ROOF**  
 General nature of work **LONGWALL RETREAT (UNI-DI)**  
 Machine used **EICKHOFF D.E.R.D.S.**  
 Machine info

<u>Sprays</u>	Drum	Venturi	Other	84	Not operating	7
	Clearer					
	Shearer					
	Loader					
	Crusher					

Seam thickness (m)  
*(if less than mining height)*  
 Mining height (m) **2.60**  
 Drum Diameter (m) **2.00**  
 Drum Rpm Main (m) **42**

Other dust suppression methods

**INHALABLE DUST REPORT**

Time Started **09.35 hrs** Finished **13.50 hrs** Estimated production (Tonnes) **2000**

Filter No	Location/Comments		Respirator	Beard	Result (mg/m <sup>3</sup> )	Alpha-Quartz (mg/m <sup>3</sup> )
106372	13 C/T LW 10	STATIC SAMPLE		-	1.2	-
106373	BELT RD 13 C/T LW 10	STATIC SAMPLE		-	2.3	-
106374	BSL	STATIC SAMPLE		-	2.0	-
106375	HRS NO. 1 #	STATIC SAMPLE		-	96.0	-
106376	HRS NO. 5 #	STATIC SAMPLE		-	231.0	-

Remarks **TEST NO. 1 WAS CONDUCTED WITH ALL DUST SUPPRESSION SYSTEMS TURNED OFF EXCEPT FOR SHEARER DRUM SPRAYS. ALL SAMPLES TAKEN WERE STATIC EXCEPT FOR SHEARER OPERATORS M/G AND T/G. TEST UNDERTAKEN UNDER NORMAL PRODUCTION SEQUENCES WITH OPERATORS STILL OPERATING SUPPORTS AT T/G MANUALLY. VARIOUS DELAYS OCCURRED DURING SAMPLING PERIOD INCLUDING BELTS, SHEARER ELECTRICAL, SHEAR PINS ETC.**

Sampled by **Stephen Holmes** Weighed by **Stephen Holmes**  
**533 Lake Road Argenton Laboratory**  
 Issued Date **18/Oct/2010** Approved signatory **Gary Mace (Manager Occupational Hygiene Services)**

**VENTILATION INFORMATION**

Ventilation type

	Maingate	No 8 Chock	Midface	-	Tailgate
Air Velocity (m/s)	0.0	0.0		0.0	0.0
Quantity (m <sup>3</sup> /s)	0.0	0.0	0.0	0.0	0.0

*Ventilation readings are approximate only and are not covered by this laboratory's terms of accreditation.*

Comments **Test No. 1 - All dust suppression turned off.**



**GRAVIMETRIC  
AIRBORNE DUST  
SAMPLING REPORT**



NATA Accredited Laboratory  
Number : 10781  
This document is issued in accordance  
with NATA's accreditation requirements.

**UNDERGROUND - LONGWALL**

**SPECIAL**

Test no. **S 262/10**  
 Mine **INTEGRA COAL - U/G OPERATIONS**  
 Test date   
 Seam   
 Location of tests **LW 10**  
 Material being worked **COAL/STONE FLOOR & ROOF**  
 General nature of work **LONGWALL RETREAT (UNI-DI)**  
 Machine used **EICKHOFF D.E.R.D.S.**  
 Machine info

Sprays	Drum	Venturi	Other	84	Not operating	7
Clearer						
Shearer						
Loader						
Crusher						

Seam thickness (m)  
*(if less than mining height)*  
 Mining height (m) **2.60**  
 Drum Diameter (m) **2.00**  
 Drum Rpm Main (m) **42**

Other dust suppression methods

**INHALABLE DUST REPORT**

Time Started **09.35 hrs** Finished **13.50 hrs** Estimated production (Tonnes) **2000**

Filter No	Location/Comments	Respirator	Beard	Result (mg/m <sup>3</sup> )	Alpha-Quartz (mg/m <sup>3</sup> )
106377	HRS NO. 65 #	STATIC SAMPLE	-	29.0	-
106378	HRS NO. 85 #	STATIC SAMPLE	-	22.0	-
106379	T/G HRS	STATIC SAMPLE	-	49.0	-
106380	HRS NO. 25 #	STATIC SAMPLE	-	19.0	-
106381	HRS NO. 45 #	STATIC SAMPLE	-	36.0	-

**Remarks** TEST NO. 1 WAS CONDUCTED WITH ALL DUST SUPPRESSION SYSTEMS TURNED OFF EXCEPT FOR SHEARER DRUM SPRAYS. ALL SAMPLES TAKEN WERE STATIC EXCEPT FOR SHEARER OPERATORS M/G AND T/G. TEST UNDERTAKEN UNDER NORMAL PRODUCTION SEQUENCES WITH OPERATORS STILL OPERATING SUPPORTS AT T/G MANUALLY. VARIOUS DELAYS OCCURRED DURING SAMPLING PERIOD INCLUDING BELTS, SHEARER ELECTRICAL, SHEAR PINS ETC.

Sampled by **Stephen Holmes** Weighed by **Stephen Holmes**  
 533 Lake Road Argenton Laboratory  
 Issued Date **18/Oct/2010** Approved signatory **Gary Mace (Manager Occupational Hygiene Services)**

**VENTILATION INFORMATION**

Ventilation type

	Maingate	No 8 Chock	Midface	-	Tailgate
Air Velocity (m/s)	0.0	0.0		0.0	0.0
Quantity (m <sup>3</sup> /s)	0.0	0.0	0.0	0.0	0.0

*Ventilation readings are approximate only and are not covered by this laboratory's terms of accreditation.*

**Comments** Test No. 1 - All dust suppression turned off.



**GRAVIMETRIC  
AIRBORNE DUST  
SAMPLING REPORT**

**UNDERGROUND - LONGWALL**



NATA Accredited Laboratory  
Number : 10781  
This document is issued in accordance  
with NATA's accreditation requirements.

**SPECIAL**

Test no. **S 263/10**  
 Mine   
 Test date   
 Seam **LIDDELL**  
 Location of tests **LW 10**  
 Material being worked **COAL/STONE FLOOR & ROOF**  
 General nature of work **LONGWALL RETREAT (UNI-DI)**  
 Machine used **EICKHOFF D.E.R.D.S.**  
 Machine info

Sprays	Drum	Venturi	Other	84	Not operating	7
Clearer				0		0
Shearer				3		0
Loader				2		0
Crusher				16		

Seam thickness (m)  
*(if less than mining height)*  
 Mining height (m) **2.60**  
 Drum Diameter (m) **2.00**  
 Drum Rpm Main (m) **42**

Other dust suppression methods

**INHALABLE DUST REPORT**

Time Started **14.40 hrs** Finished **17.10 hrs** Estimated production (Tonnes) **2000**

Filter No	Location/Comments		Respirator	Beard	Result (mg/m <sup>3</sup> )	Alpha-Quartz (mg/m <sup>3</sup> )
106396	13 C/T LW 10	STATIC SAMPLE		-	18.0	-
106397	13 C/T BELT RD LW 10	STATIC SAMPLE		-	3.3	-
106398	BSL	STATIC SAMPLE		-	2.7	-
106399	HRS NO. 1 #	STATIC SAMPLE		-	22.0	-
106400	HRS NO. 5 #	STATIC SAMPLE		-	8.6	-

Remarks **TEST NO. 2 WAS SAMPLED WITH ALL DUST SUPPRESSION APPLIED - CRUSHER SPRAYS, BSL DELIVERY, AFC SPRAY ARMS X 1.**

Sampled by **Stephen Holmes** Weighed by **Stephen Holmes**  
 Issued Date **18/Oct/2010** Approved signatory **Gary Mace (Manager - Occupational Hygiene Services)**  
 533 Lake Road Argenton Laboratory

**VENTILATION INFORMATION**

Ventilation type

	Maingate	No 8 Chock	Midface	-	Tailgate
Air Velocity (m/s)	0.0	0.0		0.0	0.0
Quantity (m <sup>3</sup> /s)	0.0	0.0	0.0	0.0	0.0

*Ventilation readings are approximate only and are not covered by this laboratory's terms of accreditation.*

Comments **See Attached Vent Survey.**