

University of Wollongong
Research Online

Faculty of Informatics - Papers (Archive)

Faculty of Engineering and Information
Sciences

1-1-2003

Allocating harmonic emission to MV customers in long feeder systems

D A. Robinson
University of Wollongong, duane@uow.edu.au

Victor J. Gosbell
University of Wollongong, vgosbell@uow.edu.au

Follow this and additional works at: <https://ro.uow.edu.au/infopapers>



Part of the [Physical Sciences and Mathematics Commons](#)

Recommended Citation

Robinson, D A. and Gosbell, Victor J.: Allocating harmonic emission to MV customers in long feeder systems 2003.
<https://ro.uow.edu.au/infopapers/1205>

Research Online is the open access institutional repository for the University of Wollongong. For further information contact the UOW Library: research-pubs@uow.edu.au

Allocating harmonic emission to MV customers in long feeder systems

Abstract

Previous work has attempted to find satisfactory methods for the allocation of harmonic current emission MV subsystems containing long feeders. It has been proposed that best use of the network's harmonic absorption capacity is made if the allocated current varies with the inverse square root of the harmonic impedance at the point of connection. It has been shown that an exact solution following this principle requires an impracticably large amount of data. Here it is assumed that each feeder supplied from a given substation has its load distributed uniformly and continuously along it, giving equations requiring only a modest amount of data. It is demonstrated by means of a suitable example that the method is sufficiently accurate for practical situations where loads are lumped non-uniformly.

Keywords

feeder, long, systems, customers, allocating, mv, emission, harmonic

Disciplines

Physical Sciences and Mathematics

Publication Details

D. A. Robinson & V. J. Gosbell, "Allocating harmonic emission to MV customers in long feeder systems," in AUPEC2003, 2003, pp. 48 -1-48-6.

Allocating harmonic emission to MV customers in long feeder systems

V.J. Gosbell and D. Robinson
Integral Energy Power Quality Centre
University of Wollongong

Abstract

Previous work has attempted to find satisfactory methods for the allocation of harmonic current emission MV subsystems containing long feeders. It has been proposed that best use of the network's harmonic absorption capacity is made if the allocated current varies with the inverse square root of the harmonic impedance at the point of connection. It has been shown that an exact solution following this principle requires an impracticably large amount of data. Here it is assumed that each feeder supplied from a given substation has its load distributed uniformly and continuously along it, giving equations requiring only a modest amount of data. It is demonstrated by means of a suitable example that the method is sufficiently accurate for practical situations where loads are lumped non-uniformly.

1. INTRODUCTION

AS/NZS 61000.3.6 (based on IEC 61000-3-6 and referred to subsequently as the Standard) gives a procedure for utilities to allocate harmonic current emission to MV customers [1]. One possible allocation strategy is to give an equal share of the harmonic voltage absorption capacity of the local network to all installations of equal maximum demand. The allocated current is then given by the allocated voltage divided by the harmonic impedance at the point of common connection (PCC). When these installations are spread out on a long feeder, for example 5 or more km in length, there can be a 5:1 or more change in fault level. Hence installations at the far end will be allocated a comparatively lower harmonic current. Another option is that installations of equal maximum demand are allocated an equal share of the harmonic current absorption capacity of the local network. This has the difficulty that equally sized installations close to the supply point are limited to the same current as the most distant load, greatly restricting the harmonic absorption capacity of the system.

The Standard recommends an intermediate option, the allocation of equal share of the harmonic volt-amperes, equivalent to varying the harmonic current with the inverse square root of the harmonic impedance at the PCC. An example is given in the Standard to show the application of the method. The particular case given involves all feeders being equally loaded, and as shown in [2], this leads to a great reduction in the data required and the analysis can be made exactly. Practical cases require an impractical amount of data for an exact solution. [2] shows some methods for estimating upper and lower bounds for the harmonic allocation, but the method requires engineering experience and judgement for reliable application.

This paper proposes a new method which will provide more accurate analysis of the harmonic allocation problem for a wide range of system types. The key step is the replacement of the several lumped loads distributed along a feeder by a uniform continuous load. This leads to a system which is capable of exact mathematical solution and requiring only a modest amount of data. A couple of examples will show that the uniform load model is accurate enough for typical harmonic application studies.

In order to present the approach without undue complexity, two simplifications will be made.

- (i) The contribution from LV loads will be ignored.
- (ii) All numerical calculations will be restricted to the 5th harmonic.

The correction of the theory to allow for the effect of LV loads is simple in concept but leads to cumbersome equations [3]. Calculation of harmonics other than the 5th are seldom required as they are usually small and insignificant [4].

2. OVERVIEW OF AS/NZS 61000.3.6

The Standard is applicable to MV systems (MV defined by the IEC as 1-35kV line-line) drawing distorting current with harmonics in the range 2-40. It outlines both utility and customer responsibilities. Utilities have to ensure their net harmonic voltage levels are less than their Planning Levels, with typical values at 11kV of 5% at the 5th harmonic, falling to 0.2% at high harmonics. It needs to be noted that Planning Levels are reduced at each successively higher voltage level, with 1% 5th harmonic being common at transmission voltage levels. Customers have to limit their harmonic current emission to the values allocated by utilities and stated in connection agreements.

The utility is a distribution company at MV. It has a major difficulty in assessing a particular customer's

allocation since the harmonic voltage at any point is made up from the time-varying contribution of many loads, most of which will not be known in detail. Distributors often do not have complete records of their system parameters, for example the impedance seen by each of their MV customers. The Standard has developed a method based on a statistical average view of the system and the customers.

Time-variation is accounted for by the specification of all harmonic currents and voltages by their 95% values. The relationship of the harmonic voltage and current of one customer are given by harmonic impedances, where resistances are ignored. The combined effect of many harmonic sources is approximated by the Standard's Second Summation Law which has been partially established by theory and by observation [5]. In the case of two harmonic voltages having 95% values V_1 and V_2 , the 95% value of the resultant voltage is

$$V = \sqrt[{\alpha}]{V_1^{\alpha} + V_2^{\alpha}} \quad (1)$$

where α varies with the harmonic order and is 1.4 for the 5th harmonic and accounts for time and phase diversity.

The allocation of harmonic current to one customer cannot be made without some assumptions about the operation of the system and the harmonic injection of all other customers connected to neighbouring parts of the subsystem. In the simple case where all customers are connected to the busbar of the zone substation (zero length feeders) the recommended assumptions are

- (i) The system is operating with all present and future customers connected.
- (ii) All customers are using their full harmonic allocation rights.
- (iii) The upstream supply has harmonic distortion at its full Planning Level.
- (iv) All contributions combine according to the Second Summation Law.
- (v) The highest voltage in the system just reaches the local Planning Level.

Suppose now that the local and upstream Planning Levels are L_h and L_{USh} . Application of the Second Summation Law will give a voltage (the so-called global emission voltage in the Standard) to be distributed to the local MV loads given by

$$G_h = \sqrt[{\alpha}]{L_h^{\alpha} - L_{USh}^{\alpha}} \quad (2)$$

An additional assumption is required regarding the relative allocation to all customers. The Standard adopts what is sometimes called the "equal rights premise" - all customers of equal maximum demand connected to the same supply point are to receive equal harmonic current (and therefore equal harmonic voltage) allocations. Suppose now that the total supply capability is S_t and that an allocation is to be

made to a customer "i" having maximum demand S_i . Because of the non-linear nature of the Second Summation Law, the voltage allocation is given by

$$E_{Uhi} = \sqrt[{\alpha}]{\frac{S_i}{S_t}} \quad (3)$$

The current allocation is then determined by the harmonic impedance x_h at the supply busbar.

$$E_{Ihi} = \frac{E_{Uhi}}{x_h} \quad (4)$$

This approach proves unsatisfactory when the customers are distributed along a long feeder (one or more km long) where there are significant changes in fault level. If customers with equal maximum demand are allocated equal harmonic voltage, the current allocation given by eqn(4) will be much smaller for customers near the far end of a feeder. Alternatively, if customers with equal maximum demand are allocated equal harmonic current, the allocation will need to be small to reduce the impact of customers at the far end. This will lead to a great reduction in the capacity of the system to absorb harmonics.

The Standard recommends the allocation of equal volt-amperes in such cases. The approach is sound but it is not detailed and is illustrated with a poorly chosen example in which all feeders and all loads are identical. Although it is not clear from the example, the method can only be applied to more practical cases if every load and the impedance at its point of connection is known. MV systems generally consist of about 10 feeders, each having a conductor type which changes throughout its length. There can be 100 or more MV loads connected to the various feeder for each zone substation. It is inconvenient, with present database systems, to find all the information required for harmonic allocation purposes.

[2, 6] represent attempts to develop methods of analysis having sufficient accuracy and requiring considerably less data. The starting point is to use a modified allocation policy

$$E_{Ihi} = \frac{k S_i^{\frac{1}{\alpha}}}{\sqrt{x_{hi}}} \quad (5)$$

where k , the allocation constant, is determined by the need to keep the far end of the weakest feeder at the Planning Level. This will be the feeder whose far end voltage will first reach the planning level as the system is loaded up. This is most likely to be the system having the largest $S \times l$ product (S being load supplied and l is length). Several methods have been developed, none of which can be guaranteed to be accurate in all cases. However, the various approaches do serve to bracket the correct solution.

3. NEW APPROACH – UNIFORM LOADING APPROACH

It is assumed that each feeder is loaded uniformly and continuously, although each feeder can have a different length and total loading. Suppose a feeder has a total load of S , an impedance x_1 at the supply end, and an impedance Rx_1 at the far end. Let α be the exponent used in the Second Summation Law. Then it is shown in the Appendix that the harmonic current allocated to the feeder is approximated by

$$I_h = k_h S^{(1/\alpha)} / \sqrt{(hx_1)} \times R^{-0.3} \quad (6)$$

where k_h is an allocation constant required to be determined. It is also shown that the harmonic voltage at the far end of the feeder due to its MV loads is approximated by

$$V_h = k_h \sqrt{(hx_1)} S^{(1/\alpha)} \times R^{0.33} \quad (7)$$

Fig. 1 shows a system in which a feeder with total MV load S_1 is the weakest. Other feeders, not shown individually, carry total MV loads S_2 . Let us determine the total voltage at the sending end busbar due to the harmonic contributions of these loads. The upstream fundamental reactance at the busbar is x_1 .

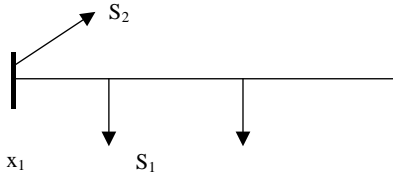

Fig. 1 - Study feeder

The voltage at the far end of the weakest feeder due to its load S_1 can be found from (8)

$$V_{h1} = k_h \sqrt{(hx_1)} S_1^{(1/\alpha)} R_1^{0.33} \quad (8)$$

The currents at the sending end bus due to S_2 can be found from (9)

$$I_{h2} = k_h S_2^{(1/\alpha)} / \sqrt{(hx_1)} R_2^{-0.3} \quad (9)$$

The corresponding harmonic voltage due to S_2 is

$$V_{h2} = k_h \sqrt{(hx_1)} S_2^{(1/\alpha)} R_2^{-0.3} \quad (10)$$

It is recommended that R_2 be chosen to be the average value of the ratio of the sending end to far end fault levels for all the feeders connected to the upstream bus, other than the weakest. Where there is some uncertainty, values for individual feeders can be combined weighted according to the MVA supplied. The harmonic voltage at the far end of the feeder is found from combining eqns(8, 10) with the upstream component L_{USh} using the power law

$$\begin{aligned} V_h^\alpha &= L_{USh}^\alpha + (k_h \sqrt{(hx_1)})^\alpha S_1 R_1^{0.33\alpha} \\ &\quad + (k_h \sqrt{(hx_1)})^\alpha S_2 R_2^{-0.3\alpha} \\ &= L_{USh}^\alpha + (k_h \sqrt{(hx_1)})^\alpha (S_1 R_1^{0.33\alpha} + S_2 R_2^{-0.3\alpha}) \end{aligned} \quad (11)$$

If the planning level for the far end of the feeder is L_h , we find

$$k_h = \frac{\alpha \sqrt{\frac{L_h^\alpha - L_{USh}^\alpha}{(S_1 R_1^{0.33\alpha} + S_2 R_2^{-0.3\alpha})}}}{\sqrt{hx_1}} \quad (12)$$

We can now examine for what feeder lengths the correction terms become significant. The terms $R_1^{0.33\alpha}$ and $R_2^{-0.3\alpha}$ change from unity by 10% for R about 1.25. Hence a feeder is considered long when the ratio of the fault levels at the two ends exceeds 1.25. Now consider an 11kV feeder with a typical upstream fault level of 150MVA. Using a base of 1 MVA,

$$Z_B = V^2/S_B = 11^2/1 = 121 \Omega.$$

$$x_1 = 1/FL_1 = 0.0067 \text{ pu}$$

$$x_2 = 1.25 \times x_1 = 0.0083 \text{ pu}$$

$$x_{\text{feeder}} = x_2 - x_1 = 0.0017 \text{ pu}$$

$$x_{\text{feeder}}(\Omega) = x_{\text{feeder}} \times Z_B = 0.202 \Omega.$$

Assuming a typical reactance per km value of $x = 0.35\Omega/\text{km}$

$$\text{Length} = x_{\text{feeder}}(\Omega)/x = 0.6 \text{ km}.$$

Hence an 11kV feeder more than 0.6 km should be considered as long.

4. EXAMPLES

Two specific case studies will be investigated to illustrate the use of the new method of allocating acceptable harmonic emissions to an MV customer. The case studies will be completed for the 5th harmonic only, as mentioned in Section 1. The customer allocations will be compared with methods previously described in [2, 4]. For both cases an upstream contribution of $L_{USh}=2\%$ and a planning level of $L_h=5\%$ will be assumed. All methods are based on an allocation policy using eqn. (5), i.e. an equitable harmonic volt-ampere allocation.

4.1 Homogenous study system

The first study system is derived from an example system provided in [1]. A 20kV distribution network consists of six identical feeders all 25km in length. Each feeder contains six 500kVA MV customers, equally spaced along the feeders as shown in Fig. 2.

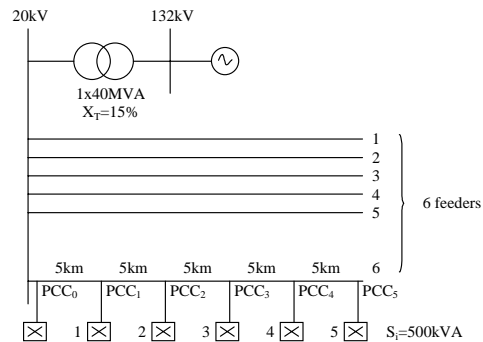

Fig. 2 - Homogenous study system from [1]

The harmonic emission allocation according to the method described in Section 3 is completed as follows. A base of $S_{base}=50MVA$ will be used. The fault level at the sending and receiving ends of each of the feeders is 234MVA and 38MVA respectively.

From the fault levels the impedance ratios are as follows

$$R_1 = R_2 = (X_{feeder} + X_{trans}) / X_{trans} = 6.83$$

Also from eqn. (12) we have the allocation constant

$$k_h = \frac{1}{\sqrt{0.21 \times 5}} \alpha \sqrt{\frac{0.05^\alpha - 0.02^\alpha}{(0.06 \times 6.83^{0.33\alpha} + 0.30 \times 6.83^{-0.3\alpha})}} = 0.1018$$

From eqn. (5) the individual harmonic emission allocated to each customer can be determined. Table I compares the allocated harmonic emissions using the principles outlined in [1] to obtain an exact solution, an alternative method proposed in [4], and the method described in Section 3.

As can be seen from Table I the method proposed in this paper produces emission allocations to each customer that are comparable to the exact, but more complex, solution provided in the Standard. This is in spite of the fact that the proposed method requires much less information than the exact solution and even less information than the more conservative method from [4].

Table I - Emission allocation for customers according to methods in [1], [4], and this paper

| Customer | E_{lhi} [1] (exact) | E_{lhi} [4] (altern) | E_{lhi} (proposed) |
|-------------------------------------|--------------------------|---------------------------|-------------------------|
| 1 | 37.5% | 27.8% | 39.2% |
| 2 | 25.5% | 18.9% | 26.6% |
| 3 | 20.6% | 15.3% | 21.5% |
| 4 | 17.7% | 13.1% | 18.5% |
| 5 | 15.8% | 11.7% | 16.5% |
| 6 | 14.4% | 10.7% | 15.0% |
| Allocation constant for each method | | | |
| k_h | 9.75% | 7.23% | 10.18% |

Using the acceptable harmonics emissions levels presented in Table I the resultant harmonic voltages along each feeder were determined for each method and are illustrated in Fig. 3. It can be seen that the proposed allocation method produces harmonic voltages that approximately match the exact allocation method. However, the proposed solution is slightly more generous to the customers than the exact solution, and thus results in harmonic voltages slightly above the planning level at the end of the feeder.

The precision of the proposed method can be improved by more accurately calculating the contribution from the weakest feeder used in determining the allocation constant k_h . This involves additional data consisting of the loading and impedances along the weakest feeder, as is required

for the method outlined in [4]. However, for this example system an error of 3% in the calculated harmonic voltage at the end of the feeder is considered well within the accuracy limitations of the summation law.

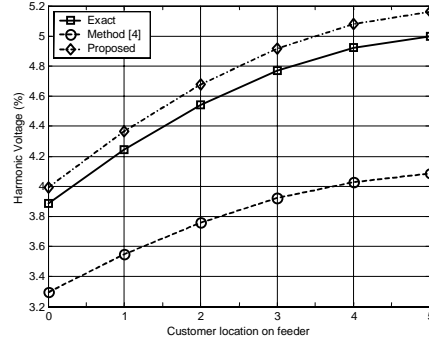

Fig. 3 - Harmonic voltages due to different allocation methods for homogenous example (note suppressed zero with vertical scale)

4.2 Extreme study system

To test the proposed method further a system containing two distinctively different feeders, as illustrated in Fig. 4 was used. The system contains one weak feeder with ten 500kVA MV customers, and one strong feeder with five 1MVA MV customers.

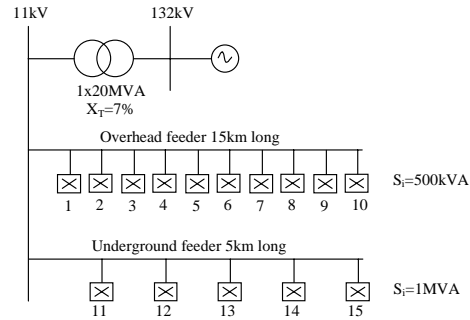

Fig. 4 – Extreme study system

The overhead line reactance and underground cable reactance is assumed to be $0.3\Omega/km$ and $0.06\Omega/km$ respectively. All loads are equally distributed along the feeders. Using the impedance values of the overhead line of the weakest feeder the value of $R_1=11.63$ is obtained. Similarly for the strong feeder the value of $R_2=1.71$ is obtained. Thus

$$k_h = \frac{1}{\sqrt{0.88 \times 5}} \alpha \sqrt{\frac{0.05^\alpha - 0.02^\alpha}{(0.1 \times 11.63^{0.33\alpha} + 0.1 \times 1.71^{-0.3\alpha})}} = 0.1361$$

The harmonic allocation constant for the exact method and the method outlined in [4] for the extreme study system were 12.22% and 11.83% respectively. The resulting harmonic voltages on the strong and weak feeders are illustrated in Fig. 5. It can be seen that the proposed method again provides results in harmonic voltages exceeding the planning levels. As with the homogenous study system this is due to

underestimating the contribution of the weakest feeder. For this extreme case the error in the resulting harmonic voltage is approximately 8%. This error may still be deemed acceptable due to the limitations of the summation law.

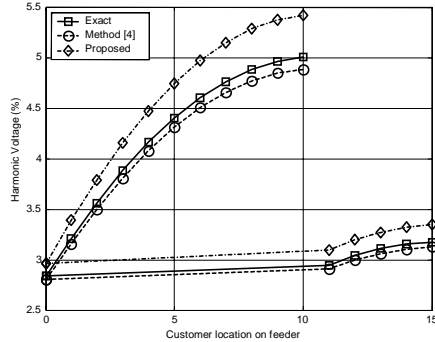

Fig. 5 - Harmonic voltages due to different allocation methods for extreme example (note suppressed zero with vertical scale)

The harmonic voltage at the end of the weakest feeder due to its contribution alone in the proposed method is estimated by eqn (8). As the loads in MV systems will usually be lumped rather than continuously distributed the exact contribution from the weakest feeder can be more accurately calculated using eqn (13)

$$V_{h1} = k_h \sum_{i=1}^n S_i X_{hi}^{\alpha/2} \quad (13)$$

This correction requires more data, but gives results which precisely match the exact method, as illustrated in Fig. 6.

5. CONCLUSIONS

A refined method of harmonic emissions allocations has been proposed which adheres to the guiding principles of the AS/NZS 61000.3.6 standard. The new method requires much less data than the detailed approach suggested in standard but produces the same level of relative accuracy. The method improves on a simple technique suggested in [4], requiring much less data in most cases, and producing less pessimistic allocations closer to the complex exact solution.

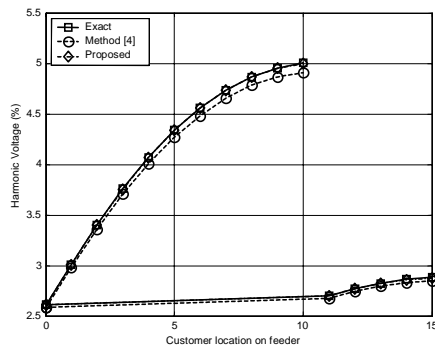

Fig. 6 - Harmonic voltages due to different allocation methods for extreme example (weakest feeder contribution corrected)

It is suggested that the accuracy of the proposed method will be sufficient to be used on most practical systems. For some extreme systems however, where feeders differ greatly in loading and impedance some correction to the method is proposed to ensure the contribution from the weakest feeder is within the required accuracy.

This method has since been adopted by a Guideline publication for application of the standard [3].

6. REFERENCES

1. AS/NZS 61000.3.6 "Limits- Assessment of emission limits for distorting loads in MV and HV power systems", Standards Australia 2001
2. V.J. Gosbell, D.A. Robinson and B.S.P. Perera and A. Baitech, "The application of IEC 61000-3-6 to MV systems in Australia", ERA Conference, Thame, Feb 2001, pp 7.1.1-7.1.10
3. V.J. Gosbell, S. Perera, V. Smith, D. Robinson and G. Sanders, "Power Quality: Application guide to AS/NZS 61000.3.6 and AS/NZS 61000.3.7", to be published by Standards Australia, late 2003
4. V. Gosbell, D. Mannix, D. Robinson & S. Perera, "Harmonic Survey of an MV Distribution System", Proc AUPEC01, Perth, September 2001, pp.338-343
5. J.M. Crucq, A. Robert, "Statistical approach for harmonics measurements and calculations", Proc CIRED 1989, pp 91-96
6. D.A. Robinson, V.J. Gosbell and B.S.P. Perera, "Harmonic allocation constant for implementation of AS/NZS 61000.3.6, Proc AUPEC01, Perth, September 2001, pp. 142-147

7. LIST OF SYMBOLS

| | |
|-----------|--|
| α | Second Summation Law exponent |
| E_{hi} | Current emission allocation for customer "i" |
| E_{Uhi} | Voltage emission allocation for customer "i" |
| FL | Fault level |
| G | Global emission voltage |
| h | Harmonic order |
| k | Allocation constant |
| L | Voltage planning level for local system |
| L_{US} | Voltage planning level for upstream system |
| R | Ration of far and supply end fault levels |
| s | Maximum demand/km |
| S | Maximum demand (VA) |
| x | Reactance |
| Z_B | Base VA |

8. APPENDIX: EQUATIONS FOR UNIFORMLY DISTRIBUTED LOADS

Let the total load on the study feeder be S. It will be assumed that the load is distributed uniformly along the feeder. Position along the feeder will be measured by x, the total fundamental reactance seen looking upstream from the point in question (Fig. 7). It is assumed to vary from x_1 to x_2 as one moves from the sending end to the far end of the feeder. x will

correspond to distance along the feeder if it is of uniform construction. It is to be noted that a change in conductor cross-section alone has only a second order effect on the variation of x with distance. Significant changes only occur when the construction changes from open wire to aerial bundle conductor (tree wire) or underground cable.

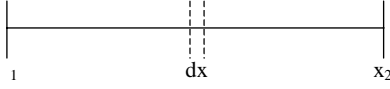

Fig. 7 – feeder with position described by upstream reactance x

Let the load connected between x and $x+dx$ be

$$dS = sdx \quad (14)$$

Integration along the feeder shows that

$$s = S/(x_2 - x_1) \quad (15)$$

As discussed in Section 2, with long feeder there are advantages in a harmonic current allocation which falls off with the inverse of the square root of upstream impedance. We shall assume the following allocation strategy

$$i_h = k_h S^{(1/\alpha)/\sqrt{hx}} \quad (16)$$

where "h" is the harmonic order.

To determine the total harmonic current in the feeder, we assume that the currents due to the many MV loads add using the power law. The contribution between x and $x+dx$ is

$$d(i_h^\alpha) = [k_h(sdx)^{(1/\alpha)/\sqrt{hx}}]^\alpha = k_h^\alpha (hx)^{-\alpha/2} sdx \quad (17)$$

Integrating from x_1 to x_2 and letting I_h be the current due to all the MV loads,

$$\begin{aligned} I_h^\alpha &= \int_{x_1}^{x_2} k_h^\alpha (hx)^{-\alpha/2} sdx \\ &= k_h^\alpha h^{-\alpha/2} \frac{(x_2^{1-\alpha/2} - x_1^{1-\alpha/2}) S}{(1-\alpha/2)(x_2 - x_1)} \\ &= k_h^\alpha h^{-\alpha/2} S \frac{x_1^{1-\alpha/2} (R^{1-\alpha/2} - 1)}{(1-\alpha/2)x_1(R-1)} \end{aligned} \quad (18)$$

$$\therefore I_h = k_h (hx_1)^{-1/2} S^{(1/\alpha)^\alpha} \sqrt{\frac{(R^{1-\alpha/2} - 1)}{(1-\alpha/2)(R-1)}} \quad (19)$$

Although the RH term appears to be complicated, a graph for several values of α shows that it can be approximated by $R^{-0.3}$ for α in the range 1-2 (Fig. 8). Hence

$$I_h \sim k_h S^{(1/\alpha)/\sqrt{hx_1}} \times R^{-0.3} \quad (20)$$

This is the same as if all the MV load was concentrated at the sending end of the feeder except for the correction term $R^{-0.3}$.

We now determine the voltage at the far end of the feeder due to all the connected MV loads. The load sdx causes a current to flow through an upstream harmonic impedance of hx . Hence

$$d(v_h^\alpha) = [k_h(sdx)^{(1/\alpha)/\sqrt{hx_1}}]^\alpha = k_h^\alpha (hx)^{\alpha/2} sdx \quad (21)$$

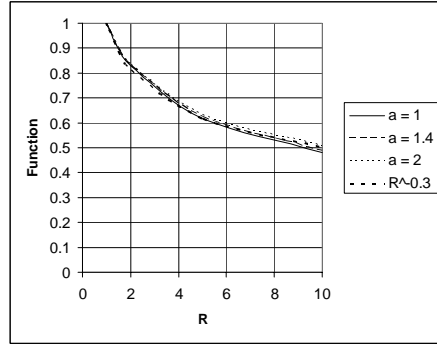

Fig. 8 – Comparison of RH term of eqn(20) with approximation

Integrating from x_1 to x_2 and letting V_h be the harmonic voltage due to all the load

$$\begin{aligned} V_h^\alpha &= \int_{x_1}^{x_2} k_h^\alpha h^{\alpha/2} s x^{\alpha/2} dx = k_h^\alpha h^{\alpha/2} \frac{(x_2^{1+\alpha/2} - x_1^{1+\alpha/2}) S}{(1+\alpha/2)(x_2 - x_1)} \\ &= \frac{k_h^\alpha h^{\alpha/2} S x_1^{1+\alpha/2} (R^{1+\alpha/2} - 1)}{(1+\alpha/2) x_1 (R-1)} \\ &= k_h^\alpha (hx_1)^{\alpha/2} S \frac{(R^{1+\alpha/2} - 1)}{(1+\alpha/2)(R-1)} \end{aligned} \quad (22)$$

$$\text{Hence } V_h = k_h \sqrt{hx_1} S^{(1/\alpha)} \sqrt{\frac{(R^{1+\alpha/2} - 1)}{(1+\alpha/2)(R-1)}} \quad (23)$$

A graph for several values of α shows that the RH term can be approximated by $R^{0.33}$ for α in the range 1-2 (Fig. 9), giving.

$$\therefore V_h \sim k_h \sqrt{hx_1} S^{(1/\alpha)} R^{0.33} \quad (24)$$

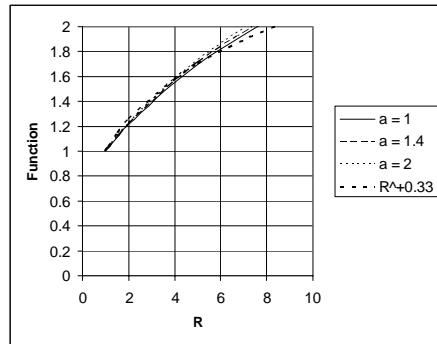

Fig. 9 – Comparison of RH term of eqn(23) with approximation

This is the same as for all the MV load concentrated at the sending end of the feeder except for the correction term $R^{0.33}$.