

University of Wollongong

Research Online

Faculty of Engineering and Information
Sciences - Papers: Part A

Faculty of Engineering and Information
Sciences

1-1-2013

The influence of pallets on the behaviour and design of drive-in steel storage racks - Part I: Behaviour

B P. Gilbert

Griffith University, b.gilbert@griffith.edu.au

L H. Teh

University of Wollongong, lteh@uow.edu.au

R X. Badet

Griffith University

K J. R Rasmussen

The University Of Sydney, k.rasmussen@usyd.edu.au

Follow this and additional works at: <https://ro.uow.edu.au/eispapers>



Part of the [Engineering Commons](#), and the [Science and Technology Studies Commons](#)

Recommended Citation

Gilbert, B P.; Teh, L H.; Badet, R X.; and Rasmussen, K J. R, "The influence of pallets on the behaviour and design of drive-in steel storage racks - Part I: Behaviour" (2013). *Faculty of Engineering and Information Sciences - Papers: Part A*. 1930.

<https://ro.uow.edu.au/eispapers/1930>

Research Online is the open access institutional repository for the University of Wollongong. For further information contact the UOW Library: research-pubs@uow.edu.au

The influence of pallets on the behaviour and design of drive-in steel storage racks - Part I: Behaviour

Abstract

Drive-in steel storage racks represent a popular alternative to the more common selective racks when available space is restricted or when storing the same good. In drive-in racks, the forklift truck drives into the rack and stores the pallets on beam rails on the "first-in last-out" principle. Recent experimental studies have shown that by acting as horizontal ties between uprights, pallets significantly influence the structural behaviour of the rack. However, due to the uncertainty in the degree of friction between the rail beams and the pallets, current industry design practice does not consider this effect. This paper quantifies the influence of the pallets on the bending moment distribution in the uprights using a 3D finite element model calibrated against experimental results on a full scale drive-in rack. Additionally, as 3D models may be computationally intensive when a large number of analyses are required, this paper presents an improved version of the 2D model of drive-in racks introduced by Godley. In the improved 2D model, all possible loading scenarios and the influence of pallets on the structural behaviour of the rack are considered. When compared to advanced 3D finite element analyses, the model is able to accurately reproduce the bending moment distribution in the upright, with and without the presence of pallets.

Keywords

part, racks, storage, steel, i, drive, influence, design, behaviour, pallets

Disciplines

Engineering | Science and Technology Studies

Publication Details

Gilbert, B. P., Teh, L. H., Badet, R. X. & Rasmussen, K. J. R. (2013). The influence of pallets on the behaviour and design of drive-in steel storage racks - Part I: Behaviour. *Research and Applications in Structural Engineering, Mechanics and Computation - Proceedings of the 5th International Conference on Structural Engineering, Mechanics and Computation, SEMC 2013* (pp. 1279-1284). CRC Press.

The influence of pallets on the behaviour and design of drive-in steel storage racks – Part I Behaviour

B.P. Gilbert

Griffith School of Engineering, Griffith University, Australia

L.H. Teh

School of Civil, Mining and Environmental Engineering, University of Wollongong, Australia

R.X. Badet

Griffith School of Engineering, Griffith University, Australia

K.J.R. Rasmussen

School of Civil Engineering, The University of Sydney, Australia

ABSTRACT: Drive-in steel storage racks represent a popular alternative to the more common selective racks when available space is restricted or when storing the same good. In drive-in racks, the forklift truck drives into the rack and stores the pallets on beam rails on the “first-in last-out” principle. Recent experimental studies have shown that by acting as horizontal ties between uprights, pallets significantly influence the structural behaviour of the rack. However, due to the uncertainty in the degree of friction between the rail beams and the pallets, current industry design practice does not consider this effect. This paper quantifies the influence of the pallets on the bending moment distribution in the uprights using a 3D finite element model calibrated against experimental results on a full scale drive-in rack. Additionally, as 3D models may be computationally intensive when a large number of analyses are required, this paper presents an improved version of the 2D model of drive-in racks introduced by Godley. In the improved 2D model, all possible loading scenarios and the influence of pallets on the structural behaviour of the rack are considered. When compared to advanced 3D finite element analyses, the model is able to accurately reproduce the bending moment distribution in the upright, with and without the presence of pallets.

1 INTRODUCTION

Worldwide, steel storage racks are extensively used in the manufacturing, wholesale and retail industry to store goods. They are mostly freestanding structures and are often assembled from cold-formed steel profiles. Two main types of racks prevail, referred to as “selective racks” and “drive-in racks”. In drive-in racks, pallets are stored on rail beams one after the other, and the forklift truck drives into the rack to store the pallets on the “first-in last-out” principle. The rail beams are offset from the centreline of the uprights so that the pallets apply both bending moments and axial compressive forces to the uprights. To allow the forklift truck passage, the rack is only braced horizontally at the top (plan bracing) and vertically at the back (spine bracing) in the down-aisle direction. Due to their floor space efficiency, drive-in racks are usually preferred to selective racks in storing the same goods with quick turnover, or in expensive storage spaces such as industrial freezers. Figure 1 shows an example of a drive-in rack.

Experimental tests performed by Gilbert and Rasmussen (2009a, 2012) have shown that pallets act as horizontal braces between adjacent uprights, significantly influence the structural behaviour of drive-in racks and must be considered in order to accurately capture the 3D behaviour of drive-in racks.

Similarly, earlier research by Salmon et al. (1973), who numerically investigated the buckling behaviour of symmetrically loaded drive-in racks by alternately considering and ignoring the pallet bracing restraints in the analysis, showed that pallet bracing restraints had significant influence on the non-sway buckling mode, although they had less influence on the sway buckling mode.



Figure 1: Example of a drive-in rack

However, due to the uncertainty concerning the friction between the pallet bases and the rail beams, drive-in racks are currently designed without considering the bracing effects.

Hua and Rasmussen (2010) measured the friction coefficient between wood pallets and rail beams and found that the average static friction coefficient between the rail beams and the pallet bases to be as high as 0.576, with a recommended a design static friction coefficient of 0.439. This friction coefficient suggests that significant horizontal forces can develop between the pallets and the rail beams before sliding occurs, allowing the pallets to play a structural role in the behaviour of drive-in racks. It is noted, however, that this design static friction coefficient does not take into account grease or ice (in the case of industrial freezers) that may accumulate on rail beams.

The current paper evaluates the influence of the horizontal bracing effect of pallets on the bending moment distribution of the upright in the down-aisle direction only, as due to the upright frames, pallets are not believed to influence the behaviour of drive-in racks in the cross-aisle direction.

The 2D analysis model for drive-in racks proposed by Godley (2002) is improved herein by introducing the horizontal restraints provided by both the rail beams and the pallet bracing restraints. All possible loading scenarios are also able to be computed in the improved model. This model is checked against the 3D model developed by Gilbert and Rasmussen (2009b, 2012) that is calibrated against laboratory test results.

2 SINGLE UPRIGHT MODEL

2.1 Single upright model proposed by Godley

In order to reduce the computation time associated with large models, Godley (2002) developed a “single upright model” to analyse fully loaded drive-in racks in the down-aisle direction. The upright is restrained at its base by a spring support having a rotational stiffness K_c , and at its top by another having a rotational stiffness K_b and a translational stiffness K_t , as shown in Figure 2. K_c represents the restraint provided by the base plate to the floor connection, K_b the restraint provided by the portal beams in double curvature (sway mode) having semi-rigid connections to the upright, and K_t the combined restraint from the plan bracing (spanning the entire rack), spine bracing (spaning one bay) and upright frames. Pallet loads and out-of-plumb loads are applied to the upright as shown in Figure 2. Detailed calculations for K_c , K_b and K_t , can be found in Godley (2002).

Despite its attractiveness, this model has limitations as it (i) ignores the restraint provided by the rail beams, (ii) does not take into account the horizontal bracing restraint provided by pallets, and (iii) does not consider all possible upright loading scenarios. The previous limitations are addressed in following sections.

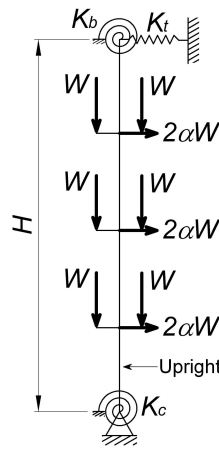

Figure 2: Drive-in rack single upright model from Godley (2002)

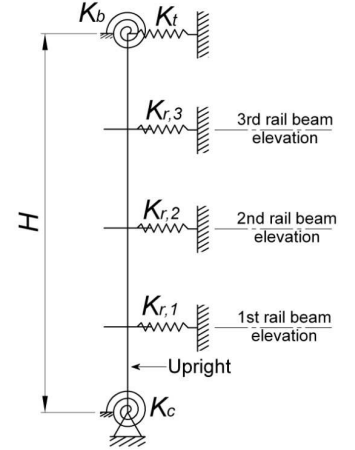

Figure 3: Single upright model with rail beam restraints for a 4 stories drive-in rack

2.2 Improved single upright model

2.2.1 Rail beam restraints

Typically, the out-of-plumb in drive-in racks is modelled by horizontal forces at the rail beam supports that are linearly proportional to the gravity loads of the pallets. For a fully loaded rail beam, the front and the back uprights are less loaded than the inner uprights, resulting in smaller out-of-plumb forces being applied to the front and back uprights. Therefore and since rail beams link the uprights together, they restrain the deflection of the inner uprights when subjected to the out-of-plumb forces.

Consequently, these restraints provided by the rail beams are introduced into the single upright model by adding a horizontal translational stiffness $K_{r,i}$ at each rail beam elevation i , as shown in Figure 3. While such an addition to the single upright model over-represents the restraints since it implies that there are no deflections of the front and back uprights, it has been found to lead to more accurate results than the neglect of same (Gilbert et al., 2013).

The stiffness $K_{r,i}$ is derived in Gilbert et al. (2013) for the critical upright (second from the front) of a drive-in rack with two upright frames and uniform spacing between uprights. For simplicity, the restraints provided by all rail beams to an upright are assumed to be independent of each other. $K_{r,i}$ is then expressed as,

$$K_{r,i} = \frac{11K_{uh,fb} - 4K_{uh,m}}{\frac{55L^3 K_{uh,fb}}{6EI_r} + 15} \quad (1)$$

where $K_{uh,fb}$ and $K_{uh,m}$ are the down-aisle stiffness of the front and back uprights and inner uprights, respectively (Gilbert et al., 2013), L is the distance between two uprights in the cross-aisle direction, E is the Young's modulus of steel and I_r is twice the second moment of area of the rail beam, as two rail beams are typically connected to the uprights.

2.2.2 Pallet bracing restraints

The bracing effect provided by the pallets is now considered for any loading scenario of a studied single upright. Bays not directly in the vicinity of this upright are assumed to be fully loaded, as it would maximise the down-aisle displacement Δ of the rack and therefore the P- Δ effects in the upright. Specifically, two loading scenarios are considered for these bays, believed to represent the two design envelopes:

- Bay loading scenario A: all bays not directly connected to the studied upright are fully loaded, as shown in Figure 4 (a).
- Bay loading scenario B: the two bays on each side of the two bays directed connected to the studied upright are empty, while remaining bays are fully loaded, as shown in Figure 4 (b). This loading scenario aims to limit the influence of the pallets on the bending moment distribution in the studied upright, as contrary to the previous bay loading scenario A, the pallets only link the studied upright and its two neighbours.

2.2.2.1 Improved model for Bay loading scenario A

In a fully loaded rack, the influence of the pallets on the deformed shape of the uprights would be minimal, as all internal uprights in a row of uprights in the down-aisle direction would identically deform. Therefore, the overall deformation of the rack at the critical row of uprights can be found using the fully loaded improved single upright model introduced in Section 2.2.1, i.e. not considering pallets, as illustrated in Figure 5. Moreover, if the number of bays of the rack is large enough, as frequently encountered in drive-in racks (see Figure 1), removing pallets from each side of the studied upright would have negligible influence on the overall deformation of the rack, and the deformation of this upright would be a function of both its immediate loading configuration and the overall deformation of the rack imposed to the upright by the portal beams and the pallet bracing restraints.

Therefore, the bracing restraint provided by the pallets for a given loading scenario of the single upright is introduced into the model in the following manner, as illustrated in Figure 6:

Step 1: The overall down-aisle displacements of the rack at each rail beam elevation and at the top of the rack are determined using the fully loaded single upright model with out-of-plumb forces, as shown in Figure 5. The base plate to floor rotational stiffness K_c , and rail beam stiffness $K_{r,i}$ are calculated for the fully loaded configuration.

Step 2: The single upright model is loaded with its studied loading scenario, with the corresponding base plate to floor rotational stiffness K_c and rail beam stiffness $K_{r,i}$.

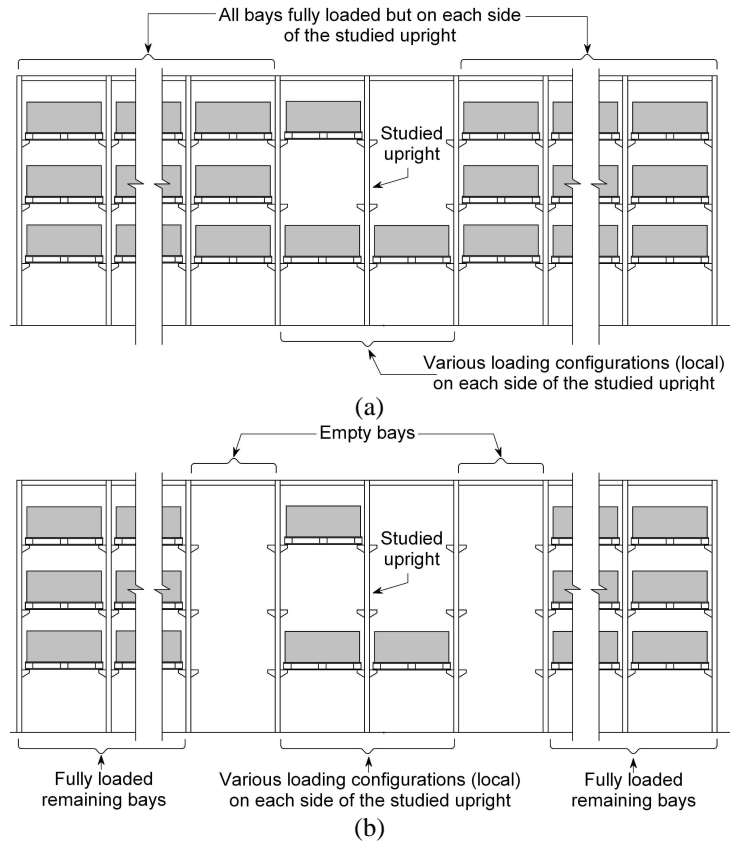

Figure 4: Studied upright for (a) Bay loading scenario A and (b) Bay loading scenario B

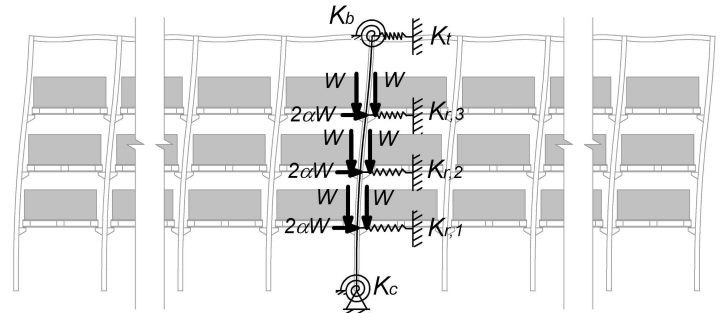

Figure 5: Deformed shape of the single upright model for a fully loaded rack

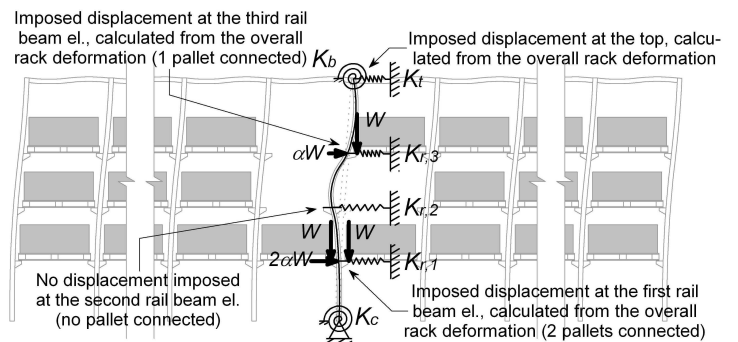

Figure 6: Improved single upright model for Bay loading scenario A

Step 3: The overall down-aisle displacement at the top of the rack (portal beam elevation) found in Step 1 is imposed at the top of the single upright model created in Step 2.

Step 4: For each rail beam elevation of the model in Step 2, if there is at least one pallet at the elevation, then the overall down-aisle displacement at that elevation found in Step 1 is imposed on the upright.

2.2.2.2 Improved model for Bay loading scenario B

As with previous Bay loading scenario A, the overall displacement imposed by the rack at the top of the critical upright in Figure 4 (b) and its two adjacent uprights can be determined from the fully loaded single upright model shown in Figure 5.

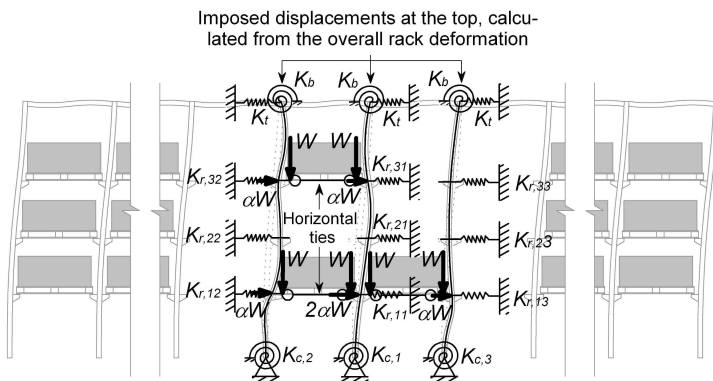

Figure 7: Improved single upright model for Bay loading scenario B

In order to determine the bending moment distribution in the studied upright for a given loading scenario of the upright, three single upright models are used and linked together by pinned rigid elements (ties) representing the pallet bracing restraints. The following steps are carried out as illustrated in Figure 7:

Step 1: The overall down-aisle displacement at the top of the rack is determined using the fully loaded single upright model with out-of-plumb forces, as shown in Figure 5. The base plate to floor rotational stiffness K_c , and rail beam stiffness $K_{r,i}$ are calculated for the fully loaded configuration.

Step 2: Three single upright models are created and loaded with the studied loading scenario, with the corresponding base plate to floor rotational stiffness K_c and rail beam stiffness $K_{r,i}$.

Step 3: The overall down-aisle displacement at the top of the rack (portal beam elevation) found in Step 1 is imposed at the top of the three uprights created in Step 2.

Step 4: Pallet bracing restraints are modelled using horizontal ties between rail beams, as shown in Figure 7.

3 INFLUENCE OF THE PALLET RESTRAINT ON THE BENDING MOMENT DISTRIBUTION AND VALIDATION OF THE SINGLE UPRIGHT MODEL

The 3D advanced Finite Element model for drive-in racks developed by Gilbert and Rasmussen Gilbert and Rasmussen (2009b, 2012) is used herein to (i) analyse the influence of the pallet restraint on the bending moment distribution in the upright and (ii) validate the improved single upright model introduced in Section 2.2. The 3D model has been calibrated against experimental test results and considers joint eccentricities, nonlinear portal beam-to-upright connections, nonlinear base-plate connections, and pallet bracing restraints, see Gilbert and Rasmussen (2009b, 2012) for more details. In the present 3D second-order analysis, the FE software Abaqus Abaqus (2010) is used, while the FE software Strand7 (2010) is used to run the 2D second-order analysis of the improved single upright model.

A rack with similar characteristics to the one tested by Gilbert and Rasmussen (2012) is used as a case study. Specifically, the rack is 12 bays wide, 4 pallets and 2 upright frames deep, and 4 stories high (i.e. featuring 3 rail beam levels). It has 3 spine bracing modules, each spanning one-bay, and 4 plan bracing modules, each spanning three bays. Each pallet is 2 tonnes. The rack is loaded as in Bay loading scenario A, described in Section 2.2.2. The shear stiffness of the pallets is taken as 7.2 N/mm, which is within the range experimentally found by Hua and Rasmussen (2010). The pallets are considered to be fastened to the rail beams as the static friction coefficient is assumed to be sufficiently high to prevent sliding. Two loading scenarios are studied, with an out-of-plumb of 0.0044 rad and other design parameters given in Gilbert et al. (2013). Further verification of the improved single upright model can be found in Gilbert et al. (2013).

3.1 First loading scenario – Maximum combined axial compression and bending

The load case involving the loading scenario shown in elevation in Figure 8 generally represents the governing load case for combined axial compression and bending of the adjacent upright to the unloaded compartment and to the aisle upright (critical upright) (FEM 10.2.07, 2010).

The down-aisle bending moment distribution of the critical upright from the 3D model accounting for pallet bracing restraints is plotted in Figure 9(a), and that obtained from the 3D model ignoring same in Figure 9(b). Figure 9 shows that the pallet bracing restraints significantly affect the bending moment distribution of the critical upright, but have only a relatively minor impact on the design bending mo-

ment. This observation appears to be general for this type of loading scenario.

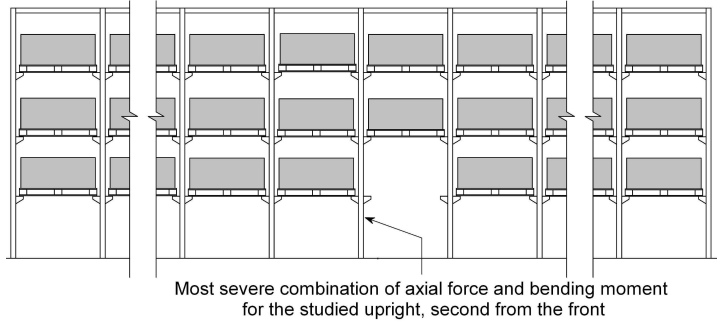

Figure 8: Loading scenario believed to generally govern the design

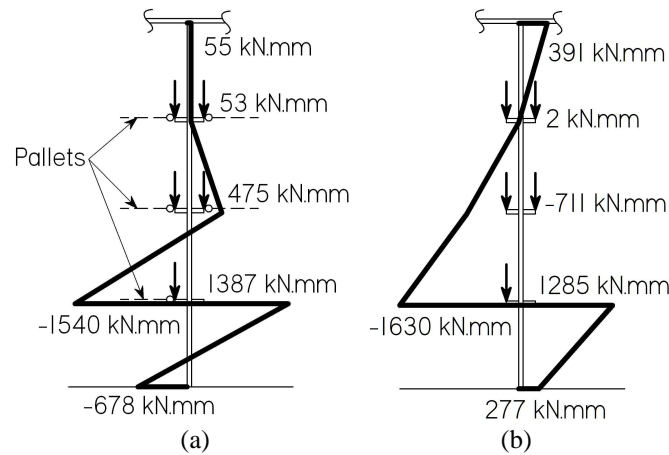

Figure 9: Bending moment distribution in the critical upright under vertical and out-of-plumb loads for the loading scenario shown in Figure 8 and 3D advanced analysis for (a) pallets considered and (b) pallets ignored

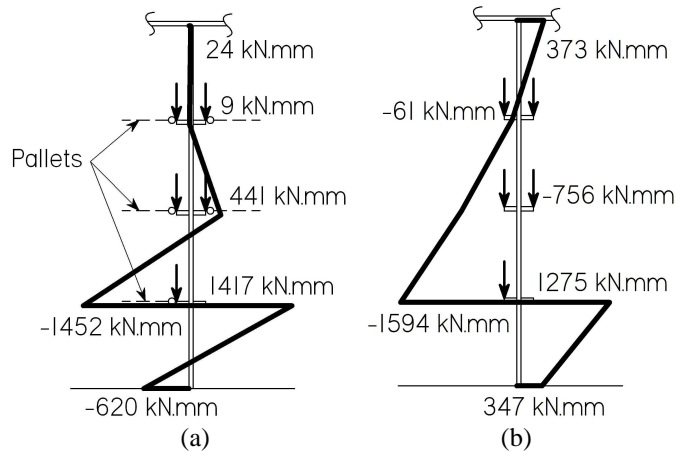

Figure 10: Bending moment distribution in the critical upright under vertical and out-of-plumb loads for the loading scenario shown in Figure 8 and 2D analyses for (a) pallets considered and (b) pallets ignored

The down-aisle bending moment distribution of the critical obtained from the single upright model accounting for pallet bracing restraints described in Section 2.2.2.1 is plotted in Figure 10 (a), and that obtained from the single upright model ignoring same (i.e. ignoring Step 4 in Section 2.2.2.1) in Figure 10 (b). It can be seen from the comparison between Figure 9 and Figure 10 that the single model

upright is able to accurately reproduce the bending moment distribution of the critical upright, with or without the pallet bracing restraints. The difference in the design bending moment between the 3D and the single upright models is less than 6%.

3.2 Second loading scenario – Maximum bending

The load case involving the loading scenario shown in Figure 11 typically incurs the largest design bending moment in the critical upright.

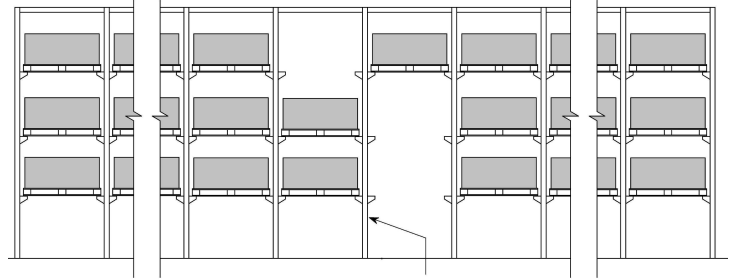

Figure 11: Loading scenario inducing maximum bending moment in a row of uprights

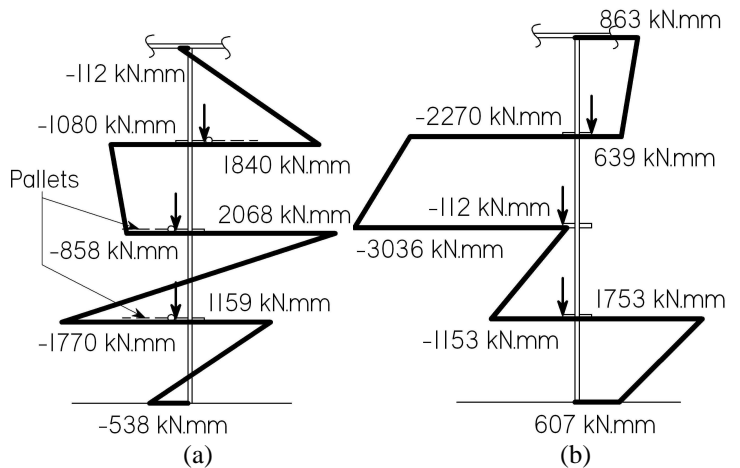

Figure 12: Bending moment distribution in the critical upright under vertical and out-of-plumb loads for the loading scenario shown in Figure 11 and 3D advanced analysis for (a) pallets considered and (b) pallets ignored

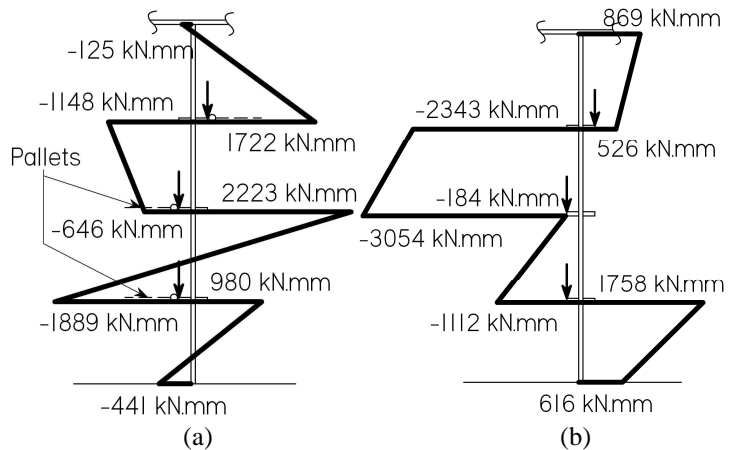

Figure 13: Bending moment distribution in the critical upright under vertical and out-of-plumb loads for the loading scenario shown in Figure 12 and 2D analyses for (a) pallets considered and (b) pallets ignored

The down-aisle bending moment distribution of the critical upright under the second load case obtained from the 3D model accounting for pallet bracing restraints is plotted in Figure 12 (a), and that obtained from the 3D model ignoring same in Figure 12 (b). Figure 12 shows that not only the pallet bracing restraints significantly affect the bending moment distribution of the critical upright, but also reduces the design bending moment by almost one third under the second load case.

The down-aisle bending moment distribution of the critical upright obtained from the single upright model accounting for pallet bracing restraints is plotted in Figure 13 (a), and that obtained from the single upright model ignoring same in Figure 13 (b). Consistent with the results for the previous loading scenario, the comparison between Figure 12 and Figure 13 shows that the single model upright is able to accurately reproduce the bending moment distribution of the critical upright, with or without the pallet bracing restraints. The difference in the design bending moment between the 3D and the single upright models is less than 7%.

4 CONCLUSION

This paper analyses the influence of horizontal bracing restraints provided by the pallets on the behaviour of steel drive-in racks. The pallets are shown to significantly influence the bending moment distribution in the uprights. The single upright model presented by Godley is improved by including the restraints provided by the rail beams and the pallets. Comparison with advanced 3D Finite Element Analyses shows that the improved model is able to accurately reproduce the bending moment distribution in the upright in the down-aisle direction under gravity and out-of plumb loads and can be used to avoid large computational time associated with 3D models.

REFERENCES

- ABAQUS 2010. *Abaqus ver. 6.10 - User manual*, Providence, U.S.A., ABAQUS, Inc.
- FEM 10.2.07 2010. Version 0.12 - Draft - The Design of 'Drive-in' and 'Drive-through' pallet racking. Federation Europeenne de la Manutention, Brussels, Belgium.
- GILBERT, B. P. & RASMUSSEN, K. J. R. 2009a. Stiffness tests, failure tests and load transfer in steel drive-in storage racks. Research Report R900. School of Civil Engineering, The University of Sydney, Australia.
- GILBERT, B. P. & RASMUSSEN, K. J. R. 2009b. Finite Element modelling of steel drive-in rack structures. Research Report R901. School of Civil Engineering, The University of Sydney, Australia.
- GILBERT, B. P. & RASMUSSEN, K. J. R. 2012. Drive-in steel storage racks I: Stiffness test and 3D load transfer

mechanisms. *ASCE Journal of Structural Engineering*, 138, 135-147.

- GILBERT, B. P., TEH, L. H., BADET, R. X. & RASMUSSEN, K. J. R. 2013. Determination of the influence of the pallets on the design of drive-in steel storage racks. Research Report CIEM/2013/R04. Centre for Infrastructure Engineering and Management, Griffith University, Australia.
- GODLEY, M. H. R. The behaviour of drive-in storage structures. *In: Laboule, R.A. & Yu, W.W., eds. 16th International Specialty Conference on Cold-Formed Steel Structures*, October, 17-18 2002 Orlando, Florida, U.S.A., 340-352.
- HUA, V. & RASMUSSEN, K. J. R. 2010. Static friction coefficient between pallets and beam rails and pallet shear stiffness tests. Research Report 914. School of Civil Engineering, The University of Sydney, Australia.
- SALMON, M. A., WELCH, R. E. & LONGINOW, A. Analysis of drive-in and drive-thru storage racks. *In: Yu, W.W., ed. 2nd Specialty Conference on Cold-Formed Steel Structures*, October, 22-24 1973 St Louis, Missouri, U.S.A., 617-639.
- STRAND7 2010. *Using Strand7 - User manual - Release 2.4.4*, Sydney, Australia, G+D Computing Pty Ltd.