

2010

The impact of mobile amusement information on use behavior, satisfaction, and loyalty

Fumiyo N. Kondo
University of Tsukuba

Jiro Hirata
University of Tsukuba

Shahriar Akter
University of Wollongong, sakter@uow.edu.au

Follow this and additional works at: <https://ro.uow.edu.au/commpapers>



Part of the [Business Commons](#), and the [Social and Behavioral Sciences Commons](#)

Recommended Citation

Kondo, Fumiyo N.; Hirata, Jiro; and Akter, Shahriar: The impact of mobile amusement information on use behavior, satisfaction, and loyalty 2010, 190-197.
<https://ro.uow.edu.au/commpapers/2784>

The impact of mobile amusement information on use behavior, satisfaction, and loyalty

Abstract

The relationship between satisfaction and loyalty has been well explored in services marketing or customer relationship management. In this study, the authors studied the relationship of 7 types of service variables under "amusement" factor. Amusement is one of the three factors extracted from 21 mobile information services. Among many different frameworks of satisfaction-loyalty, we used the framework of "past use behavior" on "satisfaction", and then of "satisfaction" on "continued use intention" (or loyalty), resulting in a strong support of the existing model with positive significant influence on the both paths. Further, our research reveals that, on the both paths, there are stronger, significant positive relationships between a latent variable and the measurement variables for mobile information services with stronger amusement elements than those with other ones. The results lead to useful implications that amusement is a crucial dimension in mobile information services, not only in use motivation, but also on behavior, satisfaction, and continued use intention.

Keywords

mobile, amusement, information, behavior, satisfaction, impact, loyalty

Disciplines

Business | Social and Behavioral Sciences

Publication Details

Kondo, F. N., Hirata, J. & Akter, S. (2010). The impact of mobile amusement information on use behavior, satisfaction, and loyalty. 2010 Ninth International Conference on Mobile Business / 2010 Ninth Global Mobility Roundtable (pp. 190-197). Athens, Greece: IEEE Computer Society.

The Impact of Mobile Amusement Information on Use Behavior, Satisfaction, and Loyalty

Fumiyo N. Kondo & Jiro Hirata

Graduate School of Systems & Information Engineering
University of Tsukuba
Tsukuba, Japan
Email: kondo@sk.tsukuba.ac.jp

Shahriar Akter

School of Information Systems
The University of New South Wales
Sydney, Australia
Email: s.akter@student.unsw.edu.au

Abstract—The relationship between satisfaction and loyalty has been well explored in services marketing or customer relationship management. In this study, the authors studied the relationship of 7 types of service variables under “amusement” factor. Amusement is one of the three factors extracted from 21 mobile information services. Among many different frameworks of satisfaction-loyalty, we used the framework of “past use behavior” on “satisfaction”, and then of “satisfaction” on “continued use intention” (or loyalty), resulting in a strong support of the existing model with positive significant influence on the both paths. Further, our research reveals that, on the both paths, there are stronger, significant positive relationships between a latent variable and the measurement variables for mobile information services with stronger amusement elements than those with other ones. The results lead to useful implications that amusement is a crucial dimension in mobile information services, not only in use motivation, but also on behavior, satisfaction, and continued use intention.

Keywords—Amusement, Entertainment, Information-intensive, Low User Ratio, Continued Use Intention, Individual Service Satisfaction, Relevance, Mobile Information Services, SEM

I. INTRODUCTION IN

The relationship between satisfaction and loyalty in service has been explored extensively in marketing. Loyalty is often interpreted as actual retention from the viewpoint of customer relationship management (CRM). Hence, there are various studies which reflect the relationship between satisfaction and loyalty in marketing as well as in CRM. Our study examines the influence of past use on satisfaction and continued use intention (or loyalty) for a various kind of mobile information services in Japan. To our knowledge, for such a various kind of mobile information services, no study examines the impact of actual use on satisfaction, and that on continued use intention.

II. LITERATURE REVIEW

A good number of studies in mobile marketing cited the significance of such relationship in case of mobile services

consumption [1]. Satisfaction is a good predictor of future intentions for low relational customers, while for high relational customers, trust and commitment are the important constructs [2]. From the view point of CRM, two different drivers of loyalty are reported, i.e., affective commitment and calculative commitment to repurchase [3, 4, 5].

According to Aydin et al. [6] customer satisfaction and customer trust in the mobile services provider have positive and direct effect on loyalty. Roos et al. [7] applied trigger theory in telecommunications industry to explore ‘switching services’ and found that the telecommunication sector is mainly influenced by influential triggers (advertising) among three triggers of situational trigger, reactional trigger and influential trigger. Bolton and Lemon [8] identified causal links between customers’ past use levels, satisfaction evaluations, and behavioral loyalty, i.e., future service use by using a dynamic model of customer use of services of telecommunications sector in US. They found that evaluation affects overall satisfaction and future use, namely the customer satisfaction mediates past and future use of services.

III. MOBILE INFORMATION SERVICES

A. Nature of Information

There are many definitions of data, information and knowledge. One operational definition of data is everything that can be sensed by humans (primarily heard and seen) and everything that can be converted into a symbolic (and therefore digital) representation. Information has been described as that subset of data, which is relevant, accurate, timely, and concise [9]. It has the characteristic that it depends on the receiver as well as the sender. Practically, information is usually generated by processing data by machines and/or humans. Eaton and Bawden [10], Cronin and Gudim [11] and Rowley [12] summarize some of the special characteristics of information. Namely, information is not lost when it is given or sold to others, the value of information is not readily quantifiable, information has no intrinsic value, and the value depends upon *context* and *user*, information can have multiple life cycles as ideas and

authors move in and out of fashion, technology facilitates and constrains the delivery of information and information may be repackaged in very different ways.

B. Mobile information services

Mobile information service is defined as the use of Internet via handheld devices [13]. With the availability of mobile devices, it becomes easy to gain access to the tremendous amounts of information on the Internet anywhere and anytime. As a result, the mobile information services have quickly become popular in recent years. Japan is one of the world's most advanced mobile markets. The number of people using mobile devices to connect to the Internet for information services in Japan has already exceeded that of stationary Internet where forty percent of mobile data revenues worldwide are being generated and three quarters of the population are using the mobile web. Four out of five users are on 3G devices [14] which facilitates comfortable access to various kind of mobile information services and a similar trend is expected worldwide [15].

Mobile technology has some distinctive features. The most unique feature is mobility which refers to the ability to communicate, inform, transact and entertain any place at anytime on the move without fixed Internet access [16]. Another unique feature is that the mobile device is personal, which is always available on a person and retains its user identity [17]. These two technological features endow mobile information applications' compelling characteristics, which differentiate them from those of other wired application. Mobile users obtain 'mobile information value' created through the use of mobile Internet applications [18].

C. Mobile information services in Japan

When the mobile Internet was born, interestingly, Japan didn't have ubiquitously available SMS. Therefore, NTT DoCoMo's mobile Internet application i-mail quickly became the de facto short messaging standard. Today, 94% of Japanese mobile users use mobile email and only 37% use SMS. I-mail is not only sold as a mobile Internet application but is also fully integrated with it, whereas SMS is neither. As an enabler for buying ring tones and wallpapers, Japanese operators (NTT DoCoMo, KDDI and SOFTBANK MOBILE Corp.) didn't use SMS either, turning straight to the mobile Internet instead. In Japan, the business model which is run by the operator and the content providers has established a platform for information marketing. Any content provider can build and launch an independent i-mode site without any operator involvement and the content firms on the i-mode portal earn 91% of the revenues their sites generate. This arrangement has resulted into enormous growth of 12,000 mobile sites included on the i-mode menu with paid-for content sold through NTT's billing platform. In addition, there are an estimated 94,000 independent sites that generate 70% of i-mode's data traffic.

All operators in Japan have already moved far beyond basic browser-like services such as mobile email and mobile

portals. NTT DoCoMo offers a wide range of advanced mobile services like i-channel which pushes information directly to a phone's idle screen. It is based on Adobe's FlashCast technology and already has more than 8 million subscribers. Another 17.4 million people use Osaifu Keitai phones that have become a standard with NTT DoCoMo's mobile wallet services and run on Sony's Near Field Communication (NFC) standard FeliCa [15]. There are many types of mobile information services such as news, weather, horoscopes, video downloads and mobile TV. Since these various kinds of mobile information services have been frequently advertised on TV in the past one year, there are good opportunities to examine the impact of satisfaction on loyalty for emerging market of mobile information services in Japan. These various types of actual information service needs require enormous importance on satisfaction-loyalty model because information services via a mobile handset require a unique, dynamic and volatile trait in decision making. For instance, the price of each information service can be paid independently and decision can occur many times as needs for services change, whereas purchasing decision of goods with many attributes is made just one time as a whole product. In case of goods, needs are relatively stable and the next purchase can be timed when the product is consumed completely or, it is easily forecasted.

IV. PROPOSED CONCEPTUAL MODEL

A. Overview of the model

Bolton and Lemon [8] identified the causal relationships among past use behavior, satisfaction, and behavioral intention in an entertainment service and a communication service by using a dynamic model in the context of US telecommunications service. They found that past use evaluation affects overall satisfaction and future use intention (loyalty) under Amemiya's Type I Tobit model. For Instance, the customer satisfaction mediates past and future use of services. Figure 1 represents our basic model of past use behavior – satisfaction – loyalty.

In the study of Bolton and Lemon, [8] past use behavior refers to what extent customers spend a particular amount for using specific information service. Satisfaction refers to the evaluation of actual information services that customers have used. Loyalty refers to what extent customers have the intention to use specific information services on a continuous basis.

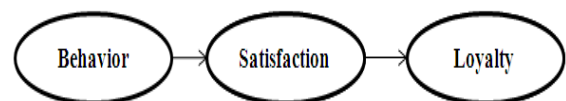

Figure 1.

B. Hypotheses Formulation

Loyalty is defined by [19] as “a deeply held commitment to rebuy or repatronize a preferred product/service consistently in the future, thereby causing repetitive same-brand or same brand-set purchasing, despite situational influences and marketing efforts having the potential to cause switching behavior”. This definition contains two aspects, *behavioral* and *attitudinal*. Our research deals with “Intention for continued use” that belongs to the behavioral loyalty.

Consumer satisfaction can lead to loyalty responses, which is empirically supported by Research in the American Customer Satisfaction Index (ACSI) [20]. Satisfied consumers are more likely to repurchase, to resist competitive offers, and to distribute positive word of mouth [8, 21, 22]. There are two kinds of satisfaction models [23]. The first one is *attribute satisfaction*, i.e., satisfaction with product or service attributes. For example, Westbrook [24] proposed that satisfaction with a retailer is an accumulation of attribute satisfaction evaluations of sales persons, store environments, products, and other factors [25]. Attribute satisfaction may be defined as a cognitive construct or a behavioral construct. The second is *overall satisfaction* or cumulative satisfaction over time, in which separate experiences are aggregated rather than a single experience [22]. According to Oliver et al. [19] overall satisfaction is defined as “pleasurable fulfillment” and is an affective response. Chiou and Cornelia [26] showed that attribute satisfaction affects overall satisfaction for the high-involvement product markets.

Our study examines the impact of actual usage frequency on satisfaction, and satisfaction on continued use intention in a causal framework under structural equation model (SEM). The uniqueness of our study lies on the fact that we deal with multiple information services provided by a mobile service provider instead of product attributes of one product. In this sense, our overall satisfaction refers to cumulative satisfaction of individual mobile information services. Therefore, instead of “attribute” satisfaction of one product, we consider “individual” satisfaction of services. In addition, we estimate three latent variables and compare the effects among the services.

Thus, we have the following alternative hypotheses on latent variables, which are basically based on the model explained in Figure 1, but are measured by various services in the dimension of “amusement” factor as follows:

1) *Past use behavior => Satisfaction*

H1: Past use frequency has significant positive relationship with satisfaction

2) *Satisfaction =>Loyalty*

H2: Satisfaction has significant positive relationship with intention to continue using.

V. METHODOLOGY

A. Data Collection

Initially, we conducted depth interview over 30 mobile phone users who have adequate experience of using mobile information services to explore the information needs and identify the crucial factors which influence their usage. Depending on this qualitative study, we developed the instrument for survey research. In this case, we appointed a professional market research firm in Japan to collect data from a panel of mobile information users who aged between 16 and 79 in a random sampling framework. Data were collected online in the period between September 18 and September 24 in 2008.

Questionnaire focusing on “Use of information services via mobile phone” was distributed to a randomly selected Internet research panel of a sample size of 20000 in 2008 and 5567 effective responses which comprises 27.8% were obtained. Out of 5567 effective responses, the number of people who have mobile phone was 5222 which comprises 93.8% of the entire effective responses. The study screens those respondents who have used mobile information services at least once in the last one year. In order to secure enough number of sample elements, we focused on only those services whose use ratios are relatively higher among 21 services in the followings:

mobile email, SMS, MMS, TV phone, radio, Internet, 1 seg TV (mobile terrestrial digital audio/video and data broadcasting service), music, ring tones, video streaming, games, learning (dictionary, translation, encyclopedia), health, infotainment content (eg., film festival or, dance party or love affairs of celebrities.), mobile chat (push talk), stock trading, shopping services, coupon, advertising information services, online storage services (data storage services on Internet), reservation or booking (e.g., hotel rooms or air line seats), location based services (GPS or map).

B. Selection of Mobile Information Services Based on Exploratory Factor Analysis

In order to find out an appropriate category of information services with high penetration rate for satisfaction-loyalty model, we conducted exploratory factor analysis on the 21 mobile information services.

We conducted factor analysis to extract common factors that exist among similar information services in terms of “awareness”, “past use behavior”, and “continued use intention.”

“Awareness”, was operationalized by asking "Are you familiar with the following mobile information services through your carrier? The 5-point Likert-type scale was anchored by very little/very well for 21 services explained in the above.

“Past use behavior” was operationalized by asking “How often do you actually use the following mobile

information services?" The 5-point Likert-type scale was used, anchored by not at all/very often dimensions for the 21 services.

"Continued use intention" was operationalized by asking "Do you have the intention to use the following mobile information services on a continuous basis?" The 5-point Likert-type scale was anchored by low / high use intention for the 21 services.

Factor analysis was based on maximum likelihood method using promax rotation that accompanies the standardization of Kaiser. We extracted three factors from twenty one information services. The Cronbach α coefficient, the reliability coefficient of measured value of questionnaire items for each construct from the point of view of internal consistency, is used to verify whether each item shows common parts within the same factor. If it is 0.7 or more, the internal consistency of measurement scale is considered to be high and reliabilities are adequate. The coefficients for each factor are shown in Table 1, respectively. Since all values exceed 0.7, items of each information service of three factors are judged that they show common parts.

Table 2 summarizes factor scores for each service within each factor. The three factors were named as follows: factor1 : *information-intensive* factor; factor2 : *amusement* factor; factor3 : *low penetration* service factor. Factor 1 refers to those services that require high degree of information, such as, reservation or stock trading. Factor 2 represents services with amusement characteristics such as ring tones or MMS, i.e., E-mail with pictures. They also have higher user ratio (the number of users divided by the number of total customers) which is more than 50%, except 1-seg TV. Finally, Factor 3 refers to those services which are infrequently used by consumers, e.g., mobile chat or online storage services. Then, through a series of factor analysis, we finally refined the measurement items and extracted three latent constructs. It is noteworthy that we excluded 1-seg TV and radio in the final measurement items in developing the SEM model. Thus, we have identified three dimensions of mobile services, that is, *information-intensive*, *amusement*, and *low penetration rate* services.

Among all the factors, the amusement dimension has higher user ratio. The dimension of "*low penetration*" appears to have an inverse relationship with service

Table 1. Cronbach's α coefficient

	factor1	factor2	factor3
AWARENESS	0.926	0.909	0.768
PAST USE	0.907	0.782	0.740
CONTINUED USE INTENTION	0.911	0.817	0.755

penetration rate. The dimension of "*information-intensive*" services represents a smaller segment of users who have interests in the specific information services. Therefore, it appears reasonable to use amusement dimension for our study. Furthermore, we decided to use those services within amusement factor that have a factor score of 40% or more and user ratio of 50% or more to ensure enough number of samples[27]. However, we included SMS within amusement factor, though it has 30% factor score, because it explains significant variance and it has a larger user base. Other services within amusement include Ring tones, MMS, Music, (mobile) E-mail, Video streaming, Games, and SMS. The service of "1 seg TV" was excluded because it had less than 50% penetration rate.

The sample size was 999 for the customers who have experience of using "amusement" services at least once, which refers to the penetration rate of more than 50%. We construct a "behavior"- "satisfaction"- "loyalty" model in a SEM framework.

C. Measurement

Question items to determine use behavior, satisfaction, and loyalty were based on both existing literature and

Table 2. Factor score and user ratio for each service

Service Items	Factor score			User Ratio
	factor1: information-intensive	factor2: amusement	factor3: low-penetration	
Reservation or booking(Ex. Hotel rooms or Air line seats)	0.885	-0.179	0.049	45.0%
Shopping services	0.865	-0.053	0.006	47.9%
Coupon. Advertising information services	0.672	0.162	-0.065	59.8%
Internet	0.67	0.331	-0.295	84.5%
Infotainment content (Ex. Film festival or, dance party or love affairs of celebrities.)	0.573	0.221	0.093	50.9%
Location based services (GPS or Map)	0.565	0.077	0.104	48.7%
Stock trading	0.534	-0.284	0.343	29.7%
Health	0.508	0.057	0.339	39.5%
Learning(dictionary, translation, encyclopedia)	0.502	0.201	0.136	53.8%
(Radio)	0.326	0.025	0.315	37.5%
Ring tones	-0.088	0.79	0.096	67.0%
MMS	-0.096	0.623	0.021	84.7%
Music	0.138	0.604	0.135	58.3%
(mobile) E-mail	0.04	0.559	-0.292	97.1%
Video streaming	0.183	0.545	0.196	50.8%
Games	0.133	0.537	0.111	57.2%
(1 seg TV (mobile terrestrial digital audio/video and data broadcasting service))	0.026	0.34	0.237	46.5%
SMS	-0.101	0.316	0.069	80.3%
Mobile chat (push talk)	-0.022	-0.057	0.91	17.7%
Online storage services(data storage services on internet)	0.372	-0.112	0.564	24.4%
TV phone	-0.085	0.19	0.518	35.4%

exploratory research. Bolton and Lemon [8] subjectively selected entertainment service and communication service for analysis. We selected high “usage rate service” objectively, resulting in the selection of the same category of services, i.e., amusement that contains entertainment and communication and have seven individual services in our research.

1) *Past Use Behavior Measurement*: Past use behavior was operationalized by asking “How often do you actually use the following mobile information services?” The 5-point Likert-type scale was used, anchored by not at all/very often dimensions for the 7 services explained in section 5.B.

2) *Satisfaction Measurement*: Individual satisfaction was operationalized by asking “Are you satisfied with the following services of your carrier? Please allocate 1-10 points on the basis of your satisfaction rate on target services in the following table (one for each, respectively), “mobile mailing services of my carrier” and “amusement”. If you find services you don’t use, please check in “I don’t use”. The 10-point Likert-type scales were anchored by very dissatisfied/very satisfied dimensions for the 7 services.

3) *Loyalty (Continued Use Intention) Measurement*: Pritchard et al. [28] introduced behavioral loyalty scale of 3 items for future monetary proportion intention, purchase frequency proportion in the past 12 months, and monetary proportion in the past 12 months. We simply asked intention to use on a continuous base because we use the question for 7 individual services. Continued use intention was operationalized by asking “Do you have the intention to use the following mobile information services on a continuous basis?” The 5-point Likert-type scales were anchored by low / high use intention for the 7 services.

For the construct of “past use behavior” and “continued use intention”, we have services of ring tones, MMS, Music, (mobile) E- mail, Games ,Video streaming, and SMS that can be considered to be a matured market. For the construct of “satisfaction”, we have two service categories of e-mail service and amusement service. It is noteworthy that we used factor analysis to extract three factors in which ‘amusement factor’ appears to contain the dimensions of “entertainment” (e.g., games) and “communication” (e.g., various kinds of E-mails).

VI. MEASUREMENT MODEL AND TESTING RESULTS

SEM is a statistical approach to understand social phenomena and natural phenomena by identifying a causal relationship between observation variables and the latent variables that cannot be observed directly. SEM consists of two types of equations, i.e., measurement equation and structural equation. Measurement equation is a set of equations that describe latent variables as common causal variables that influence on measurement variables. Structural equation is a set of equations that specifies a structure among the latent variables.

We have three models to specify the structure of error terms. The same service should have high correlation in different types of latent variables. Based on the model in Figure 1, Model 1 that has no covariance in error terms of measurement variables was constructed. Model 2 was constructed by adding non-zero covariances to model 1 in error terms between measurement variables of behavior and loyalty for each measurement. Model 3 was constructed by adding non-zero covariances to model 2 in error terms between the two measurement variables. Table 3 shows the value of model selection criterion of GFI, AGFI, RMSEA, AIC, BCC, BIC, and CAIC for each model (For each criterion, refer to [29],[30],[31],[32],[33],[34],[35], respectively). Model 3 has the largest value for GFI and AGFI, and the smallest value for the rest of the criteria and was selected as the best model and is described in Figure 2. Therefore, substantial and statistical impacts of correlations in error terms were obtained for model 3 in terms of the RMSEA and the information criteria.

The result in Table 3 showed that the path from the latent variable of “use behavior” to satisfaction and that from satisfaction to loyalty (continued use intention) becomes significant at the 1% level with the standardized value of 0.85 and 0.93, respectively. The value of Goodness-of-Fit (GFI) and adjusted goodness-of-fit Index (AGF) were 0.932 and 0.901, which exceeded 0.9 and are traditionally in the acceptable range, respectively. RMSEA is 0.070 and is considered to be a good fit [36]. The second form of parsimony fit index, i.e., AIC, BIC, BCC, and CAIC are known as “information criterion indices”. These statistics are generally used when comparing non-nested or non-hierarchical models estimated with the same data and indices to the research. The model with the Smallest “information criterion indices” is the most parsimonious and best model.

All of the coefficients of measurement variables which explain latent variables have become significant at the 1% level, so that measurement variables explain the latent variables well. Therefore, convergent validity was supported. The correlations of error terms between “use behavior” and “continued use intention” for each measurement variable are significant at the 1% level for all services. This indicates the improvements of the model occurred by considering the relationship between “use behavior” and “continued use intention” for each measurement variable specific to each service.

Further, the result showed that the higher the extent of amusement, the higher the standardized value is. Namely, high extent of amusement services such as animated graphics or ring tones has high standardized value of beta coefficient, compared to simpler E-mail services such as E-mail without or with a picture (MMS). Measurement variables of amusement services that have higher amusement characteristics have stronger relationship with the latent variables than the ones with lower amusement characteristics. For instance, the result showed that there is a

Table3. Model Selection Criteria for Each Model

	GFI	AGFI	RMSEA	AIC	BCC	BIC	CAIC
model 1	0.690	0.587	0.203	4349.168	4350.347	4515.998	4549.998
model 2	0.912	0.875	0.083	832.378	833.799	1033.555	1074.555
model 3	0.932	0.902	0.070	639.389	640.845	845.473	887.473

significant impact of amusement not only on use motivation, but also on behavior, satisfaction, and continued use intention.

For mobile advertisement, there are not many but, some researches with respect to entertainment. Tsang et al. [37] examined the model of message content characteristics->attitude->intention->behavior in SMS advertising in a SEM framework and found that ‘entertainment’ was the most important characteristics among all information aspects (Entertainment, Informativeness, Irritation, credibility) that affects attitudes toward mobile advertising. Similarly, mobile-advertising, such as [37, 38] text-based banner advertisements on the mobile Internet. Okazaki[39] examined perceived value of m-marketing, such as, *entertainment, informativeness, and credibility* together with *frequency of exposure* and mobile consumer characteristics such as *attitude towards privacy* and *age* (eg: [37, 38]).

The results of the study conducted by Lynda et al. [40] provide insights into which emotions are likely to be elicited, and how a specific marketing condition might influence their levels of intensity. Overall satisfaction is defined as ‘pleasurable fulfillment’. Our results show that ‘pleasure’

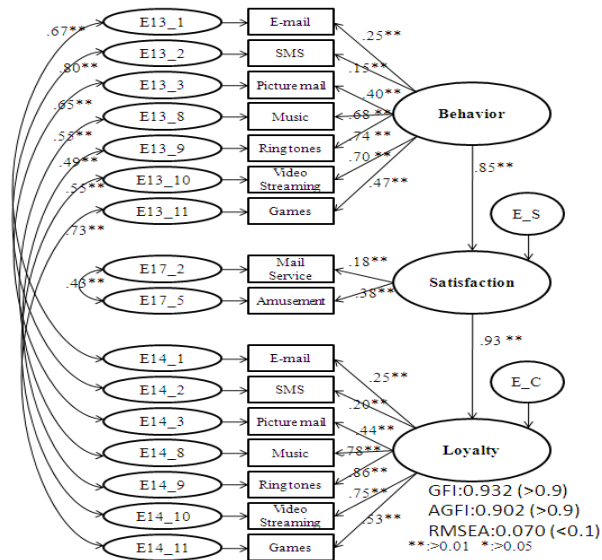

Figure 2. Path Analysis on Model 3

significantly affects mobile services usage in mobile marketing.

VII. CONCLUSION

We have identified three dimensions of use behavior-satisfaction-loyalty constructs: *low information-intensive* dimension, *amusement* dimension, and *service penetration rate* dimension. We used the dimension of *service penetration rate* to determine the range of the services that can be used for loyalty model since for low user ratio services there will be not many people who have experience in using certain services. The dimension of *information-intensive* services may be related to ‘relevance’ that can be specific to customers who have interests in the specific services and will require the relationship between the interests in the service and the characteristics of the customers. The dimension of *amusement* is the scale of amusement and the services with higher amusement values appeared frequently in the services with higher user ratio.

We focused on the analyses of behavior-satisfaction-loyalty model for the 7 services with higher values of ‘amusement’ and with higher values of user ratio. The relationship of consumers’ satisfaction and loyalty were examined in the framework of SEM. The results of this research coincide with the well established model of ‘past use’- ‘satisfaction’-‘loyalty (continued use intention)’ for the services of amusement perspective, confirming a path to influence on loyalty as the intention of future continued use from satisfaction. Further, the measurement variables for the services having higher amusement aspect, e.g. Ring tones or Music, have more relationship with latent variables. This clearly indicates the importance of amusement characteristics to affect satisfaction and loyalty in the mobile information service market in Japan. This supports that the importance of ‘amusement’ lies not only on the motivations of mobile uses, but also fully on behavior, satisfaction, and loyalty for mobile information services.

This result indicates a managerial implication that, for high user ratio services, a company should improve the quality of information services with high amusement characteristics in order to achieve high customer behavioral loyalty efficiently. For marketing researchers, this study confirmed that amusement services influence not only on motivation, but also actual use behavior, satisfaction and behavioral loyalty. This implies that the aspect of ‘amusement’ attracts customers to mobile information services.

VIII. LIMITATIONS AND FUTURE RESEARCH

Our research has some limitations on the generalizability of its findings to a single country. We could not exclude the impacts of country specific factors such as government legislation /regulations. Controls on those effects could lead toward cross cultural studies. However, this might be proven to be difficult because regulations did not take place simultaneously among the countries, and development was

also not equal. Also, as suggestions for future research, it is desired to increase consistency among measurement variables by using the same questions relating to the three latent variables.

ACKNOWLEDGEMENT

This research is supported by Grants-in-Aid for Scientific Research A, No.21243030 by Japanese government. We also express gratitude to Service Innovation Project team, University of Tsukuba, Graduate school of Systems of Information Engineering/Business Administration and Public Politics major for providing us precious data.

REFERENCES

- [1] Gerpott, T. J., Rams, W. and Schindler, A. (2001), "Customer Retention, Loyalty, and Satisfaction in the German Mobile Cellular Telecommunications Market," *Telecommunications Policy*, 25 (2001), 249-269.
- [2] Garbarino, E. and Johnson, M. S. (1999), "The Different Roles of Satisfaction, Trust, and Commitment in Customer Relationships," *Journal of Marketing*, 63 (April), 70-87.
- [3] Bendapudi, N. and Berry, L. L. (1997), "Customer Receptivity to Relationship Marketing," *Journal of Retailing*, 73(1), 15-37.
- [4] Fullerton, G. (2003), "When Does Commitment Lead to Loyalty?," *Journal of Service Research*, 5(4), 333-344.
- [5] Morgan, R. M. and Hunt, S. D. (1994), "The Commitment-trust Theory of Relationship Marketing," *Journal of Marketing*, July, 20 – 38.
- [6] Aydin, S., Ozer, G. and Arasil, O. (2005), "Customer Loyalty and the Effect of Switching Cost as a Moderator Variable: A Case in the Turkish Mobile Phone Market," *Marketing Intelligence & Planning*, Vol. 23, No.1., 2005.
- [7] Roos, I., Edvardsson, B., and Gustafsson, A. (2004), "Customer Switching Patterns in Competitive and Non-competitive Service Industries," *Journal of Service Research*, 6(3), 256-271.
- [8] Bolton, Ruth N. and Lemon, K. N. (1999), "A Dynamic Model of Customers' Use of Services: Use as an Antecedent and Consequence of Satisfaction," *Journal of Marketing Research*, 36 (May), 171-186.
- [9] Karmakar, U. and Apte, U.M. (2006), "Operations Management in the Information Economy: Information Products, Processes, and Chains," *Journal of Operations Management*, 25(2), 438-453.
- [10] Eaton JJ and Bawden, D. (1991), "What Kind of Resource is Information?," *International Journal of Information Management*, (11), 156-165.
- [11] Cronin, B. and Gudim, M. (1986), "Information and Productivity: a Review of Research," *International Journal of Information Management*, 6(2), 85–101.
- [12] Rowley, J. E. (2006), *Information Marketing*, Second Edition, published by Ashgate.
- [13] Buttle, F. (1996), "SERVQUAL: Review, Critique, Research Agenda," *European Journal of Marketing*, 30 (1), 8-32.
- [14] Billich, C., Scuka, D., and Cosh-Ishii, L. (2007), *Japan Mobile Internet Report – Carriers, Handsets, Content and Services*, Mobikyo K.K. and Wireless Watch Japan.
- [15] Forrester Research (2007), "Why Japanese Mobile Internet is a Success by Niek Van Veen," available at : www.forrester.com.
- [16] Clarke, III, I. (2001), "Emerging Value Propositions for M-Commerce," *Journal of Business Strategies*, 133-148.
- [17] Kannan, P., Chang, A., and Whinston, A., "Wireless Commerce: Marketing Issues and Possibilities," The 34th Annual Hawaii International Conference on System Sciences (HICSS-34), IEEE Computer Society Press, Maui, Hawaii, 2001.
- [18] Ankar, B and D'Incau, D. (2002), "Value Creation in Mobile Commerce: Findings from a Consumer Survey," *Journal of Information Technology Theory and Application* 4(1), pp 43-64.
- [19] Oliver, R. L., Rust, R. T. and Varki, S. (1997), Customer Delight: Foundations, Findings, and Managerial Thought," *Journal of Retailing*, 73 (3), 311-36.
- [20] Fornell, C., Johanson, M. D., Anderson, E. W., Cha, J. and Bryant, B. E. (1996), "The American Customer Satisfaction Index: Nature, Purpose, and Findings," *Journal of Marketing*, 60 (October) 7-18.
- [21] Cronin, J. J. and Taylor, S. A. (1992). Measuring Service Quality: A Reexamination and Extension," *Journal of Marketing*, 56 (July). 55-68.
- [22] Zeithaml, V., Berry, L., and Parasuraman, A. (1996) , "The Behavioral Consequences of Service Quality," *Journal of Marketing*, 60 (April). 31-36.
- [23] Bitner, M. J., and Hubbert , A. R. (1994), "Encounter Satisfaction Versus Overall Satisfaction Versus Quality," *Service Quality: New Directions in Theory and Practice*, Roland T Rust and Richard L. Oliver, eds. Thousand Oaks. CA: Sage Publications. 72-94.
- [24] Westbrook, R. A. (1981), "Sources of Consumer Satisfaction with Retail Outlets," *Journal of Retailing*, (Fall), pp. 68-85.
- [25] Spreng, R. A., MacKenzie, S. B. and Olshavsky, R. W. (1996), "A Re-Examination of the Determinants of Consumer Satisfaction," *Journal of Marketing*, 60 (July), 15-32.
- [26] Chiou, J. S. and Droge, C. (2006), "Service Quality, Trust, Specific Asset Investment and Expertise: Direct versus Indirect Effects in a Satisfaction-Loyalty Framework," *Journal of the Academy of Marketing Science*, 34:4 (Fall), 1-15.
- [27] Straub, D., Boudreau, M.-C., and Gefen, D. (2004), "Validation Guidelines for IS Positivist Research," *Communications of AIS* 13, Article 24, 380-427.
- [28] Pritchard, M. P., Havitz, M. E. and Howard, D. R. (1999), "Analyzing the Commitment-Loyalty Link in Service Contexts," *Journal of the Academy of Marketing Science* 27 (Summer): 333–348.
- [29] Jöreskog, K. J., and Sörbom, D. (1984), *LISREL-VI—Estimation of linear structural equations by maximum likelihood methods* (3rd ed.) Moorsville, IN: Scientific Software.
- [30] Tabachnick, B. j. and Fidell, L. S. (2007), "Using Multivariate Statistics (5th ed.). New York: Allyn and Bacon".
- [31] Jöreskog, K. G. and Sörbom, D. (1989), *LISREL 7: A guide to the program and applications* (2nd ed.). Chicago: SPSS.
- [32] Akaike, H. (1987), "Factor analysis and AIC," *Psychometrika*, (52) 317- 332.
- [33] Browne, M.W and Cudeck, R. (1989), "Single sample cross-validation indices for covariance structures," *Multivariate Behavioral Research*, 24, 445-455.
- [34] Schwarz, G. E. (1978). "Estimating the Dimension of a Model". *Annals of Statistics* 6 (2): 461–464.
- [35] Bozdogan, H. (1987) , "Model selection and Akaike's information criterion (AIC): The general theory and its analytical extensions", *Psychometrika*, 52(3), 345-370.
- [36] Steiger, J. H. (2007) , "Understanding the Limitations of Global Fit Assessment in Structural Equation Modeling," *Journal of personality and individual differences*, 42 (5), pp. 893-898.
- [37] Tsang, M. M., Ho, S-C. and Liang, T-P. (2004), "Consumer Attitudes toward Mobile Advertising: an Empirical Study," *International Journal of Electronic Commerce* 8 (3), 65-78.
- [38] Haghirian, P., Madlberger, M. and Tanuskova, A. (2005), "Increasing Advertising Value of Mobile Marketing: An Empirical study of antecedents," in proceedings of the 38th Hawaii International Conference on System Sciences.

- [39] Okazaki, S., (2004), "How do Japanese Consumers Perceive Wireless Advertising: A Multivariate Analysis," *International Journal of Advertising* 23 (4), 429-454.
- [40] Lynda, A., Drennan, J. and Russell-Bennett, R. (2008), "Consumers' Emotional Appraisals and Action Tendencies Arising from Mobile Viral Marketing," in proceedings of the European Marketing Academy Conference (EMAC), University of Brighton, England. 27 – 30th May 2008.