

University of Wollongong
Research Online

Coal Operators' Conference

Faculty of Engineering and Information
Sciences

2013

Modelling and design of pentice protective structures to resist high-speed projectile impacts

A. M. Remennikov
University of Wollongong, alexrem@uow.edu.au

Ryan Norton
MacMahon Engineering

Follow this and additional works at: <https://ro.uow.edu.au/coal>

Recommended Citation

A. M. Remennikov and Ryan Norton, Modelling and design of pentice protective structures to resist high-speed projectile impacts, in Naj Aziz and Bob Kininmonth (eds.), Proceedings of the 2013 Coal Operators' Conference, Mining Engineering, University of Wollongong, 18-20 February 2019
<https://ro.uow.edu.au/coal/482>

Research Online is the open access institutional repository for the University of Wollongong. For further information contact the UOW Library: research-pubs@uow.edu.au

MODELLING AND DESIGN OF PENTICE PROTECTIVE STRUCTURES TO RESIST HIGH-SPEED PROJECTILE IMPACTS

Alex Remennikov¹ and Ryan Norton²

ABSTRACT: This paper presents the results of a research study carried out to investigate the performance of the pentice structure at an underground mine in NSW during the extension and equipping of a haulage shaft by Macmahon under high-speed impact loading caused by the potential projectiles falling from the surface. This assessment will allow the structure to comply with AS 3785.5 for "Headframes" (Australian Standard, 1998).

The pentice structure is installed 1000 m below the surface in a 4.268 m diameter shaft at the considered underground mine. The objective of the pentice is to allow Macmahon construction and shaft sinking crews to work in the shaft without any risk to their safety. The pentice structure includes a number of steel boxes 1-m high that are filled with high yielding foaming grout Tekseal from Minova Australia Pty Ltd. The major aim of this investigation is to evaluate the capacity of the existing pentice to resist high-velocity impacts and to develop a high-performance protective system which is capable of absorbing energy and terminating large projectiles falling from a height of 1000 m.

High-fidelity physics based finite element models for the mine pentice were developed to find a satisfactory solution to protect workers 1000 m below the surface from potential falling projectiles. It is established that the existing level 11 pentice structure is not capable of stopping the projectiles dropping from a height of 1000 m. Several high-performance protective solutions for strengthening the pentice against impact loads were proposed and evaluated numerically. As the final design, two-level protection is designed that includes the 9 level and 11 level pentice protective structures. The models of the 9 level pentice and the 11 level pentice are evaluated for the relevant impact loads.

It is found that the new 9 level pentice requires an additional layer of the railway concrete sleepers along with the high-strength steel cover plate to provide adequate protection and terminate the falling projectiles. The supporting frames for the 9 level and 11 level pentice structures are designed using the dynamic reaction forces transferred from the pentice boxes. The developed two-level pentice protective system has proven to provide high level of protection against high-speed falling projectiles for workers performing shaft sinking duties in the shaft below.

INTRODUCTION

The mine pentice is a device used to protect workers performing shaft sinking duties to extend the existing shaft below. Macmahon contractors are in the process of extending and equipping an existing shaft from 1000 m to 1500 m deep to become the main haulage shaft at an underground mine as part of the materials handling system designed and installed by Macmahon. This requires construction crews to work in the existing upper shaft to install service pipes and fixed guides while shaft sinking crews work below to extend the shaft depth using a blind sink method. The relevant design Code used for designing this pentice structure is AS 3785.5 (Australian Standard, 1998). The protective structures shall be designed to withstand the design impact loads without significant damage or collapse. The modelling techniques developed for protecting civil infrastructure against severe impact loads (Remennikov (2007), Remennikov and Carolan (2008)) are extended in this paper to the protective structures installed inside the mine shaft.

Foam-filled steel boxes form the basis of protection structure of the pentice at this underground mine. A typical overhead protection box is shown in Figure 1. One-metre thick layer of Tekseal foaming grout is cast into the overhead boxes to act a protective energy absorption layer. The protective boxes typically have 10-mm thick steel bottom plates designed to prevent penetrations by the falling objects.

Three design impact events are considered in this study:

¹ Centre for Infrastructure Protection and Mining Safety, University of Wollongong, alex_remennikov@uow.edu.au
Tel: 02 42 215 574

² MacMahon Engineering, Perth, WA, Australia

- The falling guide of 200 x 200 x 9 SHS with a weight of approximately 475 kg.
- The falling slick line pipe of 150NB sch80 with table E flanges with a weight of approximately 530 kg.
- The falling shaft bracket with a total weight of approximately 85 kg.

All objects may potentially fall from a maximum height of 1000 m. Calculating the velocity reached from falling 1000 m (ignoring air resistance), it will be 140 m/s.

In this paper, the modelling results for a falling slick line pipe and a shaft bracket are discussed. The purpose of this investigation is to develop an effective protective design solution to protect workers working below the pentice structure against potentially lethal threat from high-speed falling projectiles.

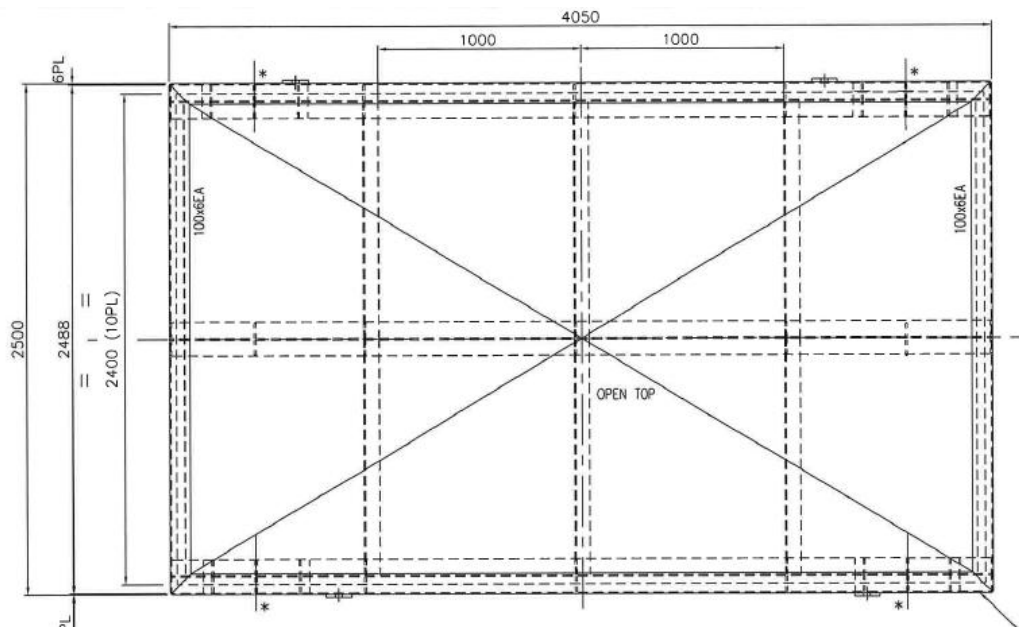

Figure 1 - Typical overhead pentice box filled with foaming grout

METHODOLOGY

Description of impact loading cases

Three typical large objects that could fall onto the pentice are considered in this study:

- **The guide** - 200x200x9 SHS with a total weight of 475 kg falling 1000 m to the pentice;
- **The slick line pipe** – 150 NB slick line pipe with flanges and with a total weight of 530 kg falling 1000 m to the pentice; and
- **The shaft bracket** - total weight of 85 kg falling 1000 m to the pentice.

Table 1 presents the details of impact events considered in this investigation. It can be seen from Table 1 that the impact event 2 (the slick line pipe) is the worst impact case with the highest energy of impact. Therefore, the slick line pipe is used in this investigation as the design load case to evaluate the effectiveness of the pentice structure for the considered underground mine in NSW. Impact event 3 is also considered and numerically modelled for cases where a reduced impact protection could be afforded.

A two-level protective pentice structure is also investigated as an alternative design involving the existing 11 level pentice and a new 9 level pentice. For this pentice design, the 9 level pentice is subjected to significantly reduced impact loading, which allows the development of a more efficient impact resisting system.

Table 1 - Parameters of potentials impact events

Impact Event	Impact Mass, kg	Drop Height, m	Impact Velocity, m/s	Energy of Impact (kJ)
1	475	1000	140	4,655
2	530	1000	140	5,194
3	52.0	1000	140	509.6

Numerical simulations using FEA models

A general purpose transient dynamic finite element software LS-DYNA (LS-DYNA, 2008) is used in this study to develop the finite element models. LS-DYNA is used to solve multi-physics problems including solid mechanics, heat transfer, and fluid dynamics either as separate phenomena or as coupled physics, e.g., thermal stress or fluid structure interaction. LS-DYNA is an industry accepted dynamic first-principle based code for analysis of structures under extreme loads generated by blast and impact events with the ability to compute large deformations due to flexure, shear, and material failures.

Since the pentice overhead boxes filled with foaming grout form the basis for protection of workers in the mine, the numerical model includes a steel box with the 6-mm thick vertical walls and 10-mm thick floor plate. The steel box is filled with 1-m thick Tekseal foaming grout as shown in Figure 1. In order to simulate an impact event, a projectile is modelled in close proximity to the slab of foaming grout and is given an initial velocity as per Table 1.

Table 2 presents a summary of finite element models developed for this study and brief description and purpose for each model.

Table 2 - Summary of FE models developed in this study

Model #	Design Concept	Models developed	Model description and purpose
1	Single Level Pentice Protective Structure (11 level pentice is to resist full design impact load)	Model of existing pentice box protected with additional 1.5 m layer of sand	Evaluates the effectiveness of sand cushion to prevent penetration of the pentice box by falling pipe.
2		Model of existing pentice box protected with additional single layer of concrete sleepers	Evaluates the effectiveness of railway sleepers to prevent penetration of the pentice box by falling pipe.
3		Model of existing pentice box protected with additional two layers of concrete sleepers	Evaluates the effectiveness of two layers of sleepers to prevent penetration of the pentice box by falling pipe.
4		Model of existing pentice box protected with additional two layers of concrete sleepers plus cover steel plate	Evaluates the effectiveness of steel cover plate in addition to two layers of concrete sleepers to stop impacting pipe.
5	Two-Level Pentice Protective Structures (9 level pentice is to resist reduced impact load and protect 11 level pentice)	Model of the 11 level pentice box impacted by a 1-ton steel section	Evaluates the performance of the existing pentice box to stop impacting projectile falling from a height of 191 m.
6		Model of supporting frame for the 11 level pentice	Evaluates the performance of the 11 level supporting structure to resist the reaction forces provided by Model #5.
7		Model of the 9 level pentice box with single layer of sleepers and steel plate on top	Evaluates the performance of the 9 level pentice box to stop a projectile falling from a height of 810 m.
8		Model of the 9 level pentice supporting structure	Evaluates the performance of the 9 level supporting structure to resist the reaction forces provided by Model #7.

Discussion of finite element models

The finite element models used in this study are shown in Figures 2 through 9. Solid elements with a single integration point are used to model the steel box walls and floor and the grouting foam infill. Overall model dimensions and the sizes of finite elements are determined from a mesh convergence study. The mesh convergence study included a number of runs of the model with variable model dimensions and increasing levels of mesh refinement. In the final model, the steel box and grout are modelled with 50-mm by 50-mm solid elements, and the areas being directly affected by the impact are modelled with 25-mm by 25-mm solid elements. Interaction between the grout material and steel box is simulated using surface to surface contact algorithms.

Several protection schemes are evaluated initially for the existing 11 level pentice. This includes adding protective layers of sand and railway concrete sleepers to enhance impact resistance of the existing pentice. Figure 2 shows the model of the existing pentice box with a 1.5-m layer of sand added over the steel cover plate. The falling 150 NB pipe impacts the sand with a velocity of 140 m/s. The sand is modelled using a hybrid modelling technique where the Lagrangian finite element mesh is combined with SPH (Smooth Particle Hydrodynamics) mesh for the sand experiencing severe deformations due to a high-speed impact.

Figure 3 shows the model of the existing pentice box with an addition of a layer of railway concrete sleepers. The model of concrete sleepers is developed based on the drawings of Austrak Heavy Duty prestressed concrete sleepers. The falling 150 NB pipe is modelled to impact the concrete sleepers with a velocity of 140 m/s. The concrete sleepers are modelled using the advanced concrete material model in LS-DYNA that allows simulation of non-linear concrete characteristics such as cracking, strength softening and damage.

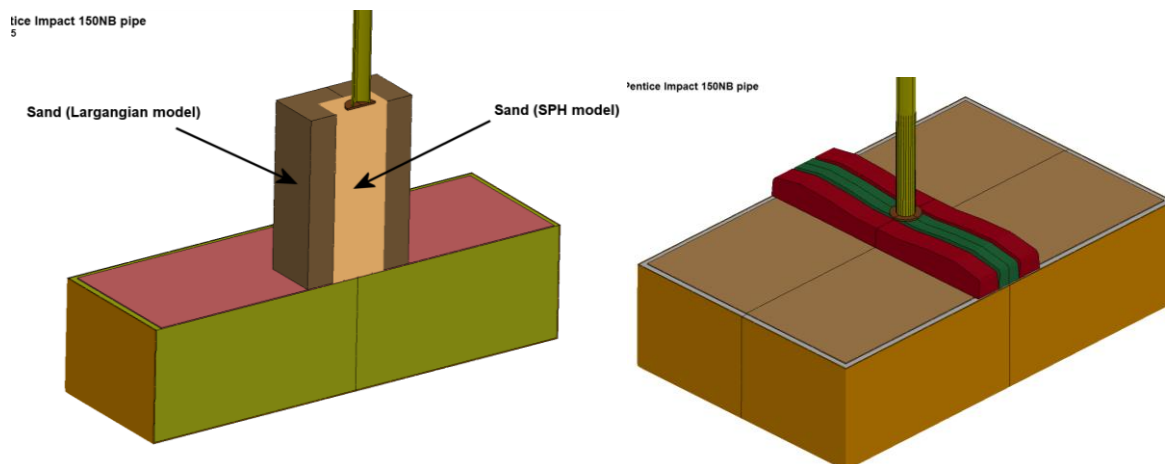

Figure 2 - Modelling sand layer protection

Figure 3 - Concrete sleepers layer protection

Figure 4 shows the model of the existing pentice box with additional two layers of railway concrete sleepers. The top layer of sleepers is subjected to the impact load from a falling 150 NB pipe with a velocity of 140 m/s. The concrete sleepers are modelled using the advanced concrete material model in LS-DYNA that allows simulation of non-linear concrete characteristics such as cracking, strength softening and damage. In Figure 5, the protective structure is enhanced with an additional 10 mm high-strength steel plate on top of the sleepers.

Model No 5 in Figure 6 is developed following the decision to provide two levels of protection by installing the 9 level pentice and the 11 level pentice to reduce the impact load demand on the pentice. Figure 7 shows the model of the 11 level pentice box filled with foaming grout with the 8-mm high-strength steel cover plate on the top. Since the 11 level pentice is located 191 m below the 9 level pentice, there is the potential for a heavy object falling from that height with a velocity of 61.2 m/s. Model No 5 simulates an impact event when a 1-ton steel section is dropped from the 9 level pentice, which represents the worst case scenario.

Model No 6 in Figure 7 is a three-dimensional steel frame that is developed to evaluate the performance of the supporting frame for the 11 level pentice. The model is developed using Strand7 computer program utilising standard beam elements. The dynamic reaction forces generated by Model 5 are applied as uniformly distributed dynamic loads to the beams supporting the pentice boxes.

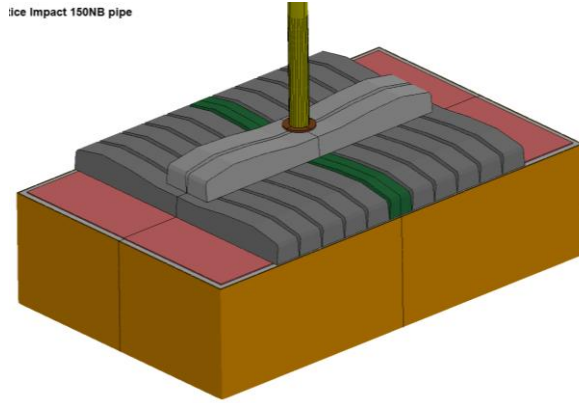

Figure 4 - Two layers of sleepers protection

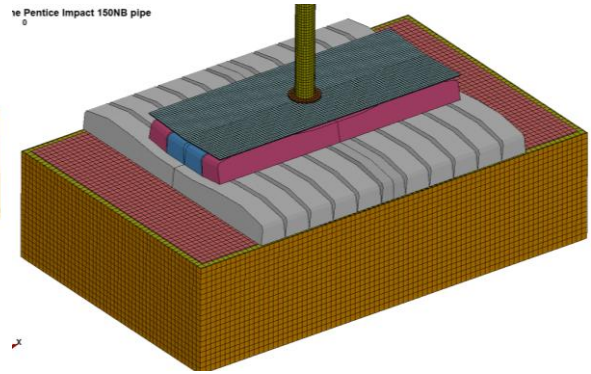

Figure 5 - Concrete sleepers and steel plate

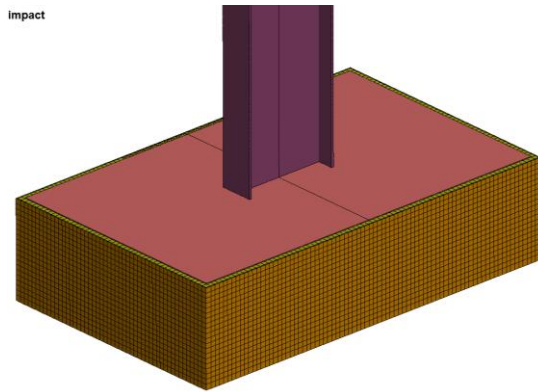

Figure 6 - 11 level pentice impact model

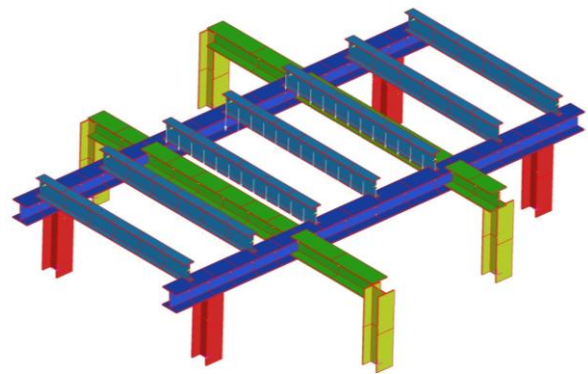

Figure 7 - 11 level support frame model

Model No 7 in Figure 8 is developed for the two-level protective system consisting of the 9 level pentice and the 11 level pentice. Figure 9 shows the model of the 9 level pentice box filled with foaming grout with the 8-mm high-strength steel cover plate and one layer of concrete sleepers on top and then the 10-mm high-strength plate on top of the sleepers. The 9 level pentice is located 810 m below the surface, therefore it is subjected to impact by the slick line pipe 150 NB falling from a height of 810 m with a velocity of 126 m/s, which is expected to deliver reduced energy of impact and thus simpler design for the pentice.

Four main steel beams spanning across the shaft and five beams supporting the pentice boxes at the 9 level are represented in Model No 8 shown in Figure 9. The model is developed using Strand7 computer program utilising standard beam elements. The dynamic reaction forces generated by Model No 7 are transferred into the Strand7 model and applied as uniformly distributed dynamic loads to the beams supporting the pentice box.

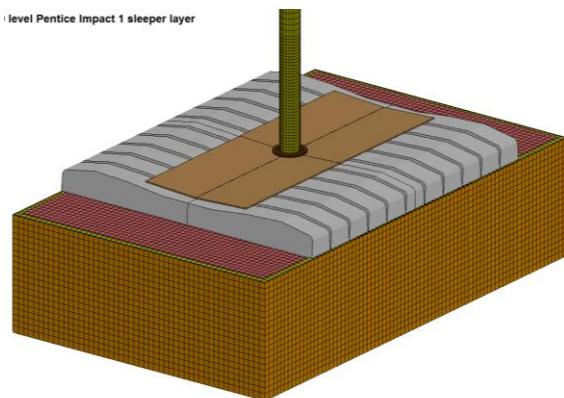

Figure 8 - 9 level pentice impact model

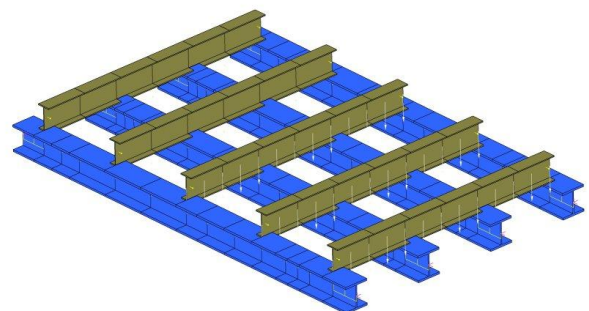

Figure 9 - 9 level support frame model

MATERIAL MODELS

Foaming grout Tekseal is modelled using Material Type 173 based on Mohr-Coulomb criterion in LS-DYNA. The material has a Mohr Coulomb yield surface, given by $\tau_{\max} = C + \sigma_n \tan(\phi)$, where τ_{\max} = maximum shear stress on any plane, σ_n = normal stress on that plane, C = cohesion, ϕ = friction angle. The tensile strength is given by $\sigma_{\max} = C / \tan(\phi)$. After the material reaches its tensile strength, further tensile straining leads to volumetric voiding.

The appropriate material modelling parameters for the Tekseal foaming grout are summarised in Table 3.

Table 3 - Material properties for 200 psi Tekseal

Material	Young's Modulus (MPa)	Poisson's Ratio	Friction Angle (deg)	Cohesion (MPa)	Compressive Strength (MPa)	Tensile Strength (MPa)
200 psi Tekseal	200	0.43	19	0.6	1.4	0.3

Steel plates of the pentice box are modelled using Material Type 3 in LS-DYNA representing elasto-plastic behaviour of the steel material. The steel is assumed to be Grade 300 with a yield stress of 300 MPa. The projectile is modelled using Material Type 20 representing absolutely rigid steel material.

High-strength steel plates placed on top of foaming grout infill and on top of concrete sleepers are placed in contact with the surfaces of the grout and sleepers and simulated using the penalty contact algorithm *CONTACT_SURFACE_TO_SURFACE in LS-DYNA. The plates are given the material properties based on the information provided by Bisalloy Steel Group Limited for Bisalloy 80. The mechanical properties of Bisalloy 80 used in the model are summarised in Table 4.

Table 4 - Material properties for Bisalloy 80

Material	0.2% Proof Stress	Tensile Strength	Elongation in 50mm GL	Hardness
Bisalloy 80	750 MPa	830 MPa	20%	255 HB

RESULTS OF NUMERICAL MODELLING

Based on the FE models shown in Figures 2 through 9 and the loading and material properties described in the previous sections, non-linear dynamic analyses are carried out for the pentice boxes and their supporting structures. All models are analysed so as to investigate an emergency impact load condition based on a 150 NB slick line pipe falling from the top surface of the mine. The results of non-linear dynamic analyses are presented and discussed below.

Response of the 11 level pentice with a layer of sand or concrete sleepers

Figure 10 demonstrates the outcome of the impact analysis of the existing 11 level pentice box subjected to impact by the 150 NB pipe with an impact velocity of 140 m/s. It can be seen that the steel pipe penetrates the layer of sand and the slab of foaming grout and perforates the 10-mm floor plate of the pentice. The analysis results indicate that a 1.5-m thick sand cushion is able to slow down the impacting pipe by only 5 m/s, thus subjecting the pentice structure to the impact velocity of 135 m/s. This results in perforation of the existing cover steel plate, penetration of the foam infill and finally in perforation of the bottom plate of the box, as shown in Figure 10. This solution is found to be ineffective for stopping the falling pipe with a velocity of 140 m/s.

A separate model of the pentice is developed to investigate the effectiveness of railway concrete sleepers to prevent penetration of the pentice by the high-speed falling pipe. The concrete sleepers are placed on top of the existing pentice and subjected to the impact load generated by the falling pipe. The results of numerical simulation are shown in Figure 11. It can be seen that the impacted sleeper is fully disintegrated and the falling pipe penetrates the 1-m deep grout and the bottom plate of the box. The sleepers contribute to slowing down the impacting pipe to 80 m/s velocity from an initial velocity of 140 m/s. This solution is found to be ineffective for stopping the falling pipe with a velocity of 140 m/s.

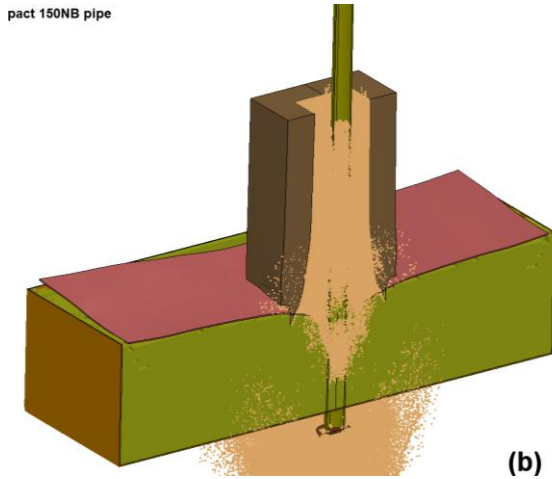

Figure 10 - Penetration through sand layer

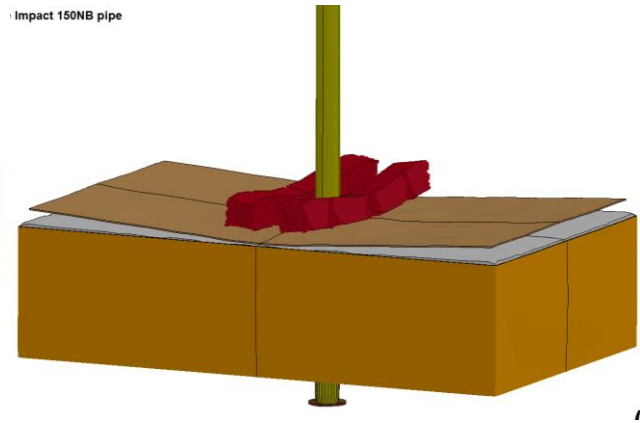

Figure 11 - Effect of single layer of sleepers

Response of the pentice with two layers of concrete sleepers

Since single layer of concrete sleepers is not effective for protecting the pentice against penetration, a model of the pentice with two layers of concrete sleepers is developed. The results of numerical simulation are shown in Figure 12. It can be seen that the pipe projectile crashed the top and bottom sleepers and penetrated the pentice box, as shown in Figure 12. Therefore, this solution is also found to be not adequate for protecting the pentice box against penetration by the projectile.

A protective system based on two layers of concrete sleepers and the cover 10 mm high-strength steel plate on top is further evaluated. The results of numerical simulation are shown in Figure 13. It is established that the sleepers directly impacted by the pipe would be severely damaged and the cover steel plate would come in contact with the existing steel plate on top of the pentice. The energy absorbed by crushing concrete sleepers is sufficient for reducing the pipe velocity to about 55 m/s, and the two plates with the foam infill stopped the projectile and prevented penetration damage of the pentice structure within about 25 msec after the impact. Therefore, this solution may be considered effective for stopping the falling pipe projectile with an impact velocity of 140 m/s.

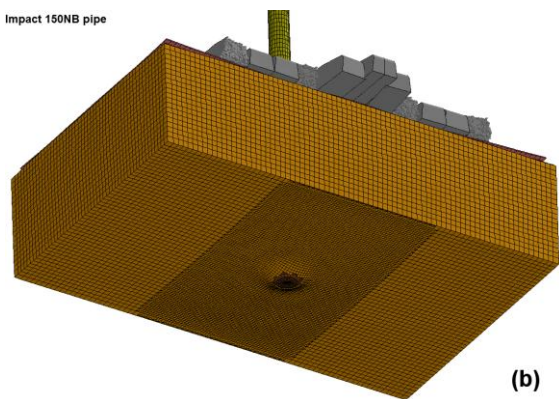

Figure 12 - Effect of two layers of sleepers

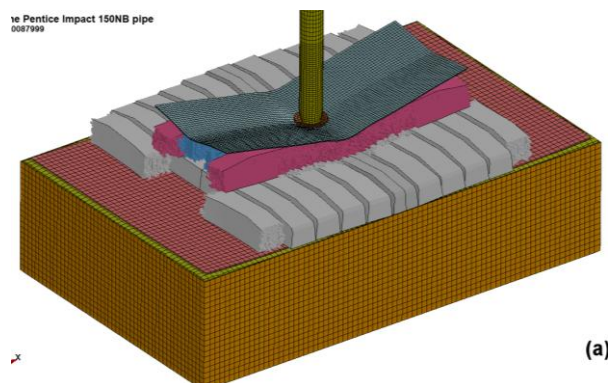

Figure 13 - Effect of sleepers and steel plate

Given that the 11 level pentice is installed more than 1000 m below ground level and there is no crane access in the shaft, development and design of the enhanced impact resistant 11 level pentice structure is not economically and technically viable. To optimise the protective structure, a two-level pentice solution is adopted and investigated next.

Response of the 11 level pentice to a 1-tonne falling section

The 11 level pentice is located 190 m below the 9 level pentice. Therefore, the protective performance of the 11 level pentice is investigated for an accidental fall of a large steel section from a height of 191 m and an impact velocity of 61.2 m/s. The results of simulation of the 11 level pentice subject to impact by a 1-tonne falling steel section are presented in Figure 14. It is established that in the final state the projectile

penetrates through the grouting foam to the depth of 950 mm. The velocity graph in Figure 14 confirms that the projectile velocity is reduced to zero from the initial value of 61.2 m/s implying that the projectile is terminated by the existing 11 level pentice. Based on these results, it is concluded that the existing 11 level pentice can provide sufficient protection against large projectiles falling from the level of the 9 pentice.

The 11 level pentice supporting frame model is analysed using the dynamic reaction forces determined from the impact analysis of the pentice box. The graph of vertical beam displacements in Figure 15 shows the peak beam deformation of about 1.5 mm, which is deemed satisfactory.

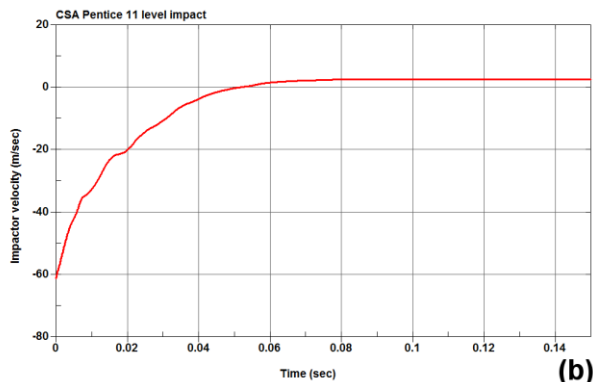

Figure 14 - Response of 11 level pentice

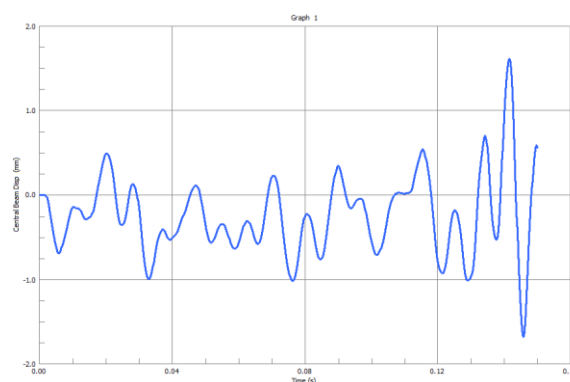

Figure 15 - Response of 11 pentice frame

Response of the 9 level pentice to impact by a slick line pipe

The 9 level pentice with one layer of concrete sleepers and the 10-mm Bisalloy plate on top is analysed for the impact loads due to a falling 150 NB pipe from a height of 810 m (126 m/s velocity). Figure 16 shows the response of this protective system. It is established that the sleepers directly impacted by the pipe would be severely damaged and the cover steel plate would come in contact with the existing steel plate on top of the pentice. As can be seen from the graph in Figure 17 the projectile velocity will be brought to zero in about 25 msec by the proposed 9 level pentice design. Therefore, this solution may be considered effective for stopping the falling possible projectiles with an impact velocity of 126 m/s.

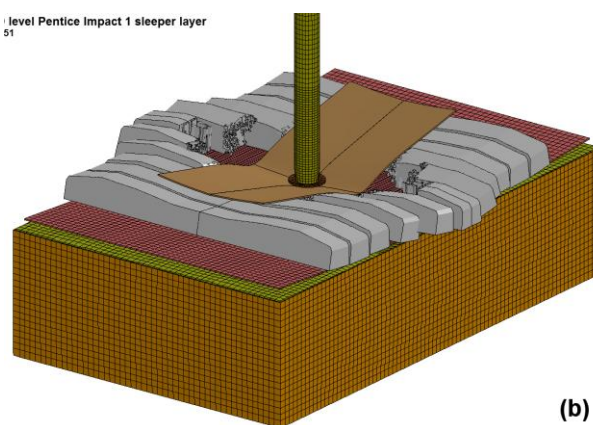

Figure 16 - Response of 9 level pentice

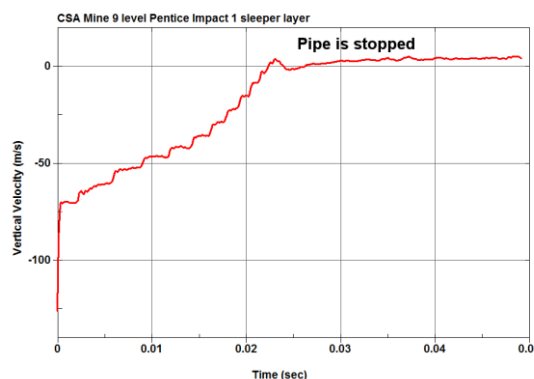

Figure 17 - Projectile velocity time history

PENTICE IMPACT ANALYSIS FOR A FALLING WALL BRACKET

The final part of this investigation is concerned with modelling the consequences of not utilising the 9 level pentice discussed above during operations of installing wall brackets. These operations require mounting the wall brackets to the wall of the mine shaft which could become high-speed projectiles if one of the brackets falls into the shaft from a maximum height of 1000 m. Considerable time and labour resources could be saved by not requiring installation of the 9 level pentice. This requires evaluation of the dynamic response of the 11 level pentice protective structures to absorb energy and terminate a falling wall bracket from a height of 1000 m.

Figure 18 shows the model of the 11 level pentice box with the 8-mm steel cover plate and the assumed orientation of the wall bracket just prior to impact. The falling wall bracket impacts the top steel plate with a velocity of 140 m/s.

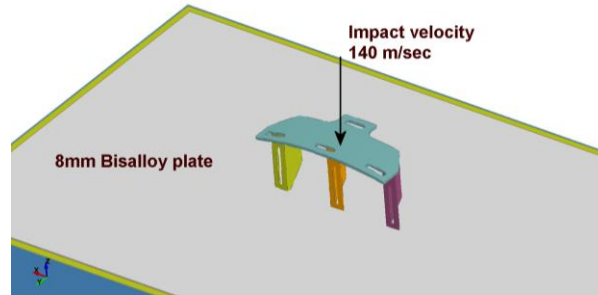

Figure 18 - Model of wall bracket impacting pentice structure

Figure 19 demonstrates the outcomes of the impact analysis of the level 11 pentice box subjected to impact by the wall bracket with an impact velocity of 140 m/s. It is seen that the steel wall bracket experiences severe plastic deformations upon impact with the top steel plate as shown in Figure 19. The wall bracket penetrates the 8-mm high-strength steel plate as demonstrated in Figure 20. From Figure 21, the wall bracket is fully stopped by the pentice protective structures within about 10-15 msec after coming into contact with the steel cover plate.

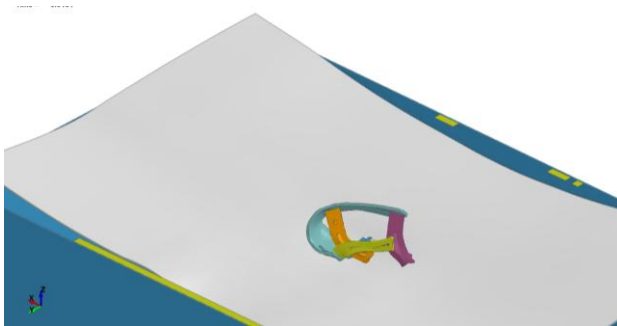

Figure 19 - Large deformations of wall bracket

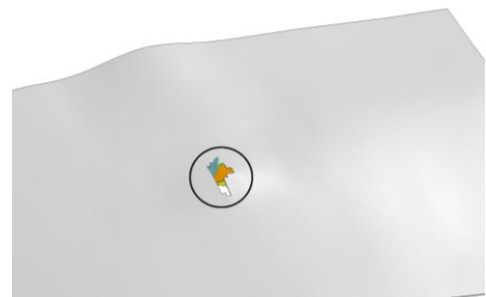

Figure 20 - Perforation of steel cover plate

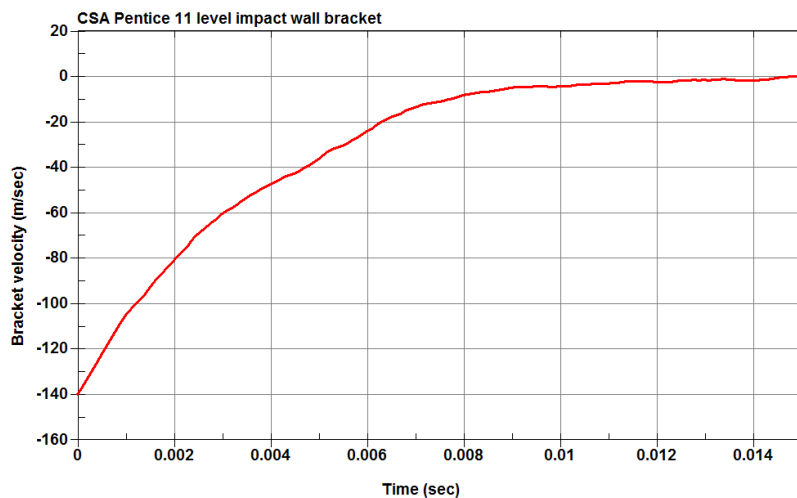

Figure 21 - Time history of wall bracket velocity

It is established that the pentice boxes filled with foaming grout and protected with a 8-mm high-strength steel cover plate provide sufficient resistance to terminate a falling 52-kg wall bracket projectile. The support frame for the 11 level pentice is also verified to resist the dynamic forces transferred from the pentice boxes during the high-speed impact.

CONCLUSIONS

In this paper, high-fidelity physics based finite element models for the underground mine 11 level pentice and 9 level pentice are developed to find a satisfactory solution to protect workers 1000 m below the surface from falling projectiles during maintenance operations. The impact velocity of a projectile falling from the surface is about 140 m/s, which requires very high level of protection to be afforded by the pentice protective structures.

Several high-performance protective solutions were proposed and evaluated for strengthening the pentice against impact loads. Given that the pentice is installed more than 1000 m below ground and the shaft area cannot be accessed with a crane, it was required to develop a protective system that would be easy to manhandle. The final design of the impact-resistant protective system includes two levels of pentice structures. The first level, the 9 level pentice, is designed to terminate the projectiles falling from the ground level. It includes a combination of railway concrete sleepers and high-strength steel cover plate to provide additional energy absorbing capacity to the pentice. The second level of protection, the 11 level pentice, does not require strengthening as it has sufficient capacity to resist impacting projectiles falling from the 9 level pentice.

The supporting frames for the 9 level pentice and the 11 level pentice were also verified and designed to have sufficient stiffness and capacity to resist the dynamic loads transferred from the pentice boxes subjected to impact. The high effectiveness of the developed protective structures is ensured by high-fidelity physics-based numerical modelling utilising three-dimensional non-linear dynamic analysis techniques in this study which can be extended to providing effective protection against the "emergency" impact events in other mining applications.

REFERENCES

- Australian Standard AS 3785.5, 1998. Underground mining - Shaft equipment - Headframes.
- LS-DYNA Version 971, 2008. Livermore Software Technology Corp., Livermore, CA, May 2008.
- Remennikov, A, 2007. Behaviour of high performance steel sections subjected to impact loads. *Proceedings of the 5th International Conference on Advances in Steel Structures*, December 2007, Singapore, pp 929-934.
- Remennikov, A M and Carolan, D, 2008. High-performance protection technologies for blast and impact retrofitting of building facades, *Australasian Structural Engineering Conference (ASEC)*, 26-27 June 2008, Melbourne [paper No.82 on CD-ROM].