

University of Wollongong

Research Online

Australian Institute for Innovative Materials -
Papers

Australian Institute for Innovative Materials

1-1-2008

A novel chipless RFID system based on planar multiresonators for barcode replacement

Stevan Preradovic
Monash University

Isaac Balbin
Monash University

Nemai Karmakar
Monash University

Gerry Swiegers
University of Wollongong, swiegers@uow.edu.au

Follow this and additional works at: <https://ro.uow.edu.au/aiimpapers>

 Part of the [Engineering Commons](#), and the [Physical Sciences and Mathematics Commons](#)

Recommended Citation

Preradovic, Stevan; Balbin, Isaac; Karmakar, Nemai; and Swiegers, Gerry, "A novel chipless RFID system based on planar multiresonators for barcode replacement" (2008). *Australian Institute for Innovative Materials - Papers*. 294.
<https://ro.uow.edu.au/aiimpapers/294>

Research Online is the open access institutional repository for the University of Wollongong. For further information contact the UOW Library: research-pubs@uow.edu.au

A novel chipless RFID system based on planar multiresonators for barcode replacement

Abstract

RFID is taking the world by storm but lowering the price of the tag is a necessity in order to completely replace barcode systems with RFID systems. Researchers around the world have been working on chipless RFID systems. In this paper we present a novel chipless RFID system for barcode replacement. The system can be effectively used in conveyor belt applications. It uses spectral signatures to encoded data and hence provide a unique ID for every tagged object. The chipless tag is fully passive and planar.

Keywords

system, rfid, chipless, planar, multiresonators, replacement, barcode, novel

Disciplines

Engineering | Physical Sciences and Mathematics

Publication Details

Preradovic, S., Balbin, I., Karmakar, N. & Swiegers, G. (2008). A novel chipless RFID system based on planar multiresonators for barcode replacement. 2008 IEEE International Conference on RFID (pp. 289-296). New York: IEEE.

A Novel Chipless RFID System Based on Planar Multiresonators for Barcode Replacement

Stevan Preradovic, Isaac Balbin, Nemaï C. Karmakar and Gerry Swiegers

Abstract— RFID is taking the world by storm but lowering the price of the tag is a necessity in order to completely replace barcode systems with RFID systems. Researchers around the world have been working on chipless RFID systems. In this paper we present a novel chipless RFID system for barcode replacement. The system can be effectively used in conveyor belt applications. It uses spectral signatures to encoded data and hence provide a unique ID for every tagged object. The chipless tag is fully passive and planar.

I. INTRODUCTION

RADIO Frequency Identification (RFID) is a new wireless data capturing technique for automatic identification in areas such as asset tracking, security surveillance etc... A RFID system consists of three major components: a reader or integrator, which sends the interrogation signals to a RFID transponder or tag, which is to be identified; a RFID tag, which contains the identification code; and a middleware, which maintains the interface between the reader and a mainframe or a personal computer.

RFID was first proposed by H. Stockman [1]. He has introduced RFID systems in his landmark paper "Communication by Means of Reflected Power" [2]. Stockman advocates that considerable research and development works need to be done to solve the basic problems of wireless identification by means of reflected power [1].

Various other identification methods like the omni-present barcode have been shown to be inadequate for current demands. The need for greater reading range and automation has put RFID technology as the premier data capturing procedure implemented widely in logistics, supply chain managements, asset tracking, security access control, and many other applications.

Due to the flexibility and numerous advantages of RFID systems as compared to barcodes and other identification

systems, RFID is now becoming a major player in the commercial market. Today, RFID is being researched and investigated by both academic and industry scientists and engineers in order to speed up the implementation of RFID technology into the mainstream. The Massachusetts Institute of Technology (MIT) founded the AUTO-ID centre to standardize RFID thus enabling faster introduction of RFID into the mainstream [3]-[5] of retail chains, identification and asset management.

The only reason RFID tags haven't replaced the barcode is due to the price of the tag which is still much higher when compared to the price of the barcode. Hence, a huge amount of investments and investigations focusing on lowering the price of the transponder have been put in motion, and the price of the RFID tag is getting lower and lower every year. The development of chipless transponders without silicon integrated circuits (ICs) has lowered the cost of the tags even more, but at the expense of requiring smarter and more agile RFID readers.

In this paper we propose a novel chipless RFID system based on multiresonators which perform frequency signature encoding. In section II we present the simulation results of the proposed system and the chipless RFID tag antenna and multiresonator circuit simulations. In section II we present the measured results and field trials of the proposed chipless RFID system. Section IV contains the conclusion along with the summary of the obtained results.

II. CHIPLESS RFID SYSTEM DESIGN

A. Novel Frequency Signature Concept for RFID

As mentioned in the introduction it is imperative to lower the price of the transponder in order to compete with the price of the barcode. This means practically that the transponder must be passive. Passive transponders do not have an on-board power supply; hence they need to extract the power from the reader's emitted RF field and rectify it to a DC voltage in order to supply the tags digital circuitry with the necessary power [6]. Advanced RF engineering alongside with compact integrated circuit design has enabled the design of RFID transponders which contain an antenna and an IC, containing the necessary RF and digital circuitry. Even with the tags simplicity (antenna and integrated circuit) the modern RFID tag cannot compete with its older brother – the barcode, in terms of price. That's why researchers and engineers have turned towards

Manuscript submitted December 31, 2007 This work was supported in part by the Australian Research Council under Discovery Grant DP0665523: *Chipless RFID for Barcode Replacement*.

S. Preradovic, I. Balbin and N. C. Karmakar are with the Department of Electrical and Computer Systems Engineering, Bldg 72 Clayton Campus, Monash University, 3800 VIC Australia (e-mail: Stevan.Preradovic@eng.monash.edu.au, Isaac.Balbin@eng.monash.edu.au, Nemai.Karmakar@eng.monash.edu.au).

Gerry Swiegers is with the Security Devices Research Group, CSIRO Molecular and Health Technologies, Bag 10, Clayton, VIC, 3169 (e-mail: Gerry.Swiegers@csiro.au)

the chipless RFID concept. Several chipless RFID systems exist of which the surface acoustic wave (SAW) based chipless tags so far present the closest to a universal chipless RFID system for barcode replacement[7]-[9].

We present a novel chipless RFID system which uses frequency signatures for data encoding. The proposed chipless RFID system is fully passive and the transponders do not need any power supply in order to operate. The chipless transponder encodes data in the frequency spectrum hence having a unique ID or “spectral signature” The spectral signature is obtained by interrogating the transponder by a multi-frequency signal and observing which frequencies are attenuated. If the signal is attenuated at a particular frequency then it represents a logic “0” otherwise it’s a logic “1”. The block diagram of the proposed chipless RFID system is shown in Fig.1.

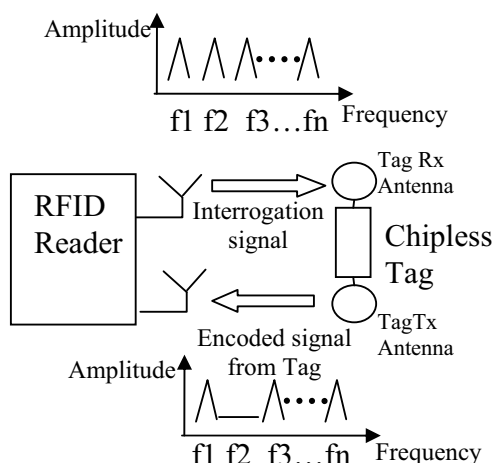

Fig. 1. Block diagram of the proposed chipless RFID system.

As it can be seen from Fig. 1 the RFID reader sends out a multi-frequency interrogation signal and the chipless transponder attenuates particular frequencies which creates a unique spectral signature. The spectral signature is created by the transponders multiresonating circuit which is a multi-stop band filter. The multiresonator is a set of cascaded spiral resonators designed to resonate at particular frequencies and create stop bands. The block diagram of the chipless RFID tag is shown in Fig. 2. It consists of a receiving tag antenna, multiresonating circuit and transmitting tag antenna. The receiving and transmitting tag antennas are cross-polarized in order to minimize interference between the interrogation signal and the re-transmitted encoded signal containing the spectral signature.

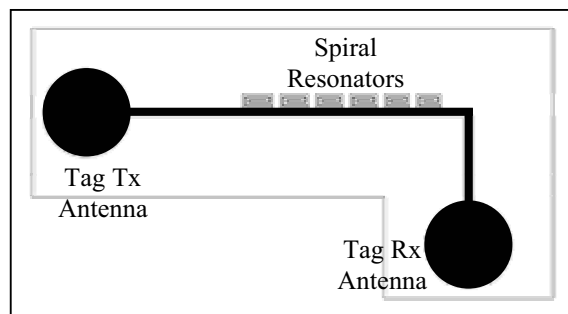

Fig. 2. Layout of the chipless RFID transponder.

The proposed chipless RFID system is a preliminary design for a conveyor belt system where the tagged items are tracked by moving through the interrogation zone of a fixed reader antenna system as shown in Fig. 3.

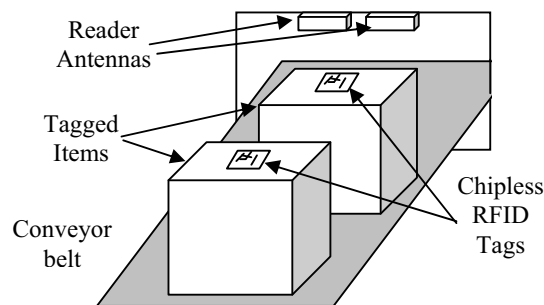

Fig. 3. Potential conveyor belt application for the proposed chipless RFID system

The operating frequency range of the chipless system is 500MHz centered around 2.25GHz, which is outside the ISM band and therefore requires licensing. The frequency band can be shifted towards the UWB operating range (3.1GHz-10.7GHz) which dictates power limitations (-40dBm EIRP indoor and -50dBm outdoor). Due to the fact that the operating range is completely determined by the reader’s sensitivity and not the transponders rectifier efficiency (due to their chipless nature, the tags do not extract power from the reader’s emitted field).

In the following sections the tag antenna and multiresonating circuit will be presented alongside the system simulation performed in ADS2005A simulation software.

B. Chipless RFID Tag Antenna Design

As mentioned, the system operates from 2GHz to 2.5GHz and hence requires antennas operating in this frequency range. The circular microstrip UWB monopole antenna was chosen due to its large frequency bandwidth and donut shape radiation pattern (omni directional in one plane). The UWB monopole was designed using ADS 2005A Momentum on Taconic TLX-0 substrate ($\epsilon_r=2.45$, $h=0.787$, $\tan D=0.0019$). The design parameters of the UWB monopole antenna are shown in Fig. 4 and Table 1. The

simulated return loss and radiation patterns are shown in Fig. 5 and 6 respectively.

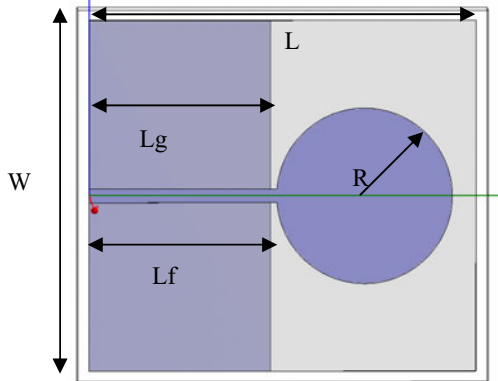

Fig. 4. UWB Monopole Antenna for chipless RFID tag

Table 1. UWB Monopole Antenna design parameters

Dimension	Value(mm)
L	66
W	60
Lg	31
Lf	32
R	15

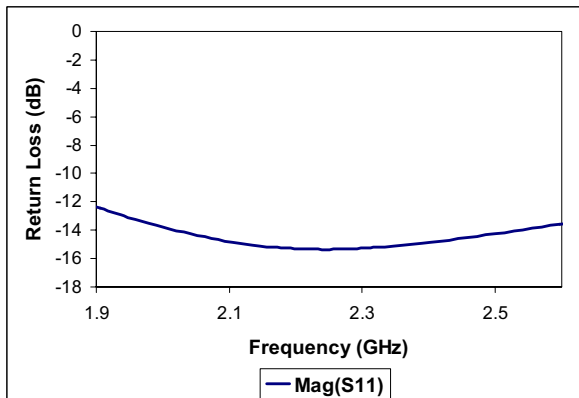

Fig. 5. Simulated return loss of the UWB tag antenna

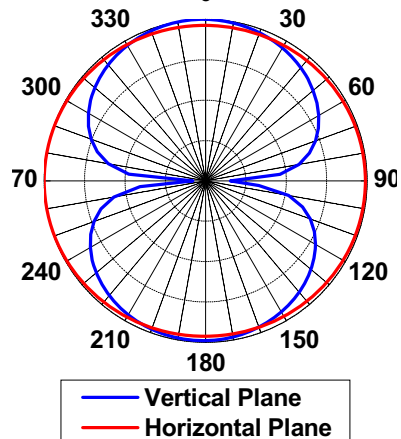

Fig. 6. Simulated radiation pattern of the UWB tag antenna

The simulation results show a return loss greater than 10dB in the desired region (2GHz – 2.5GHz) and an omni directional radiation pattern in the vertical plane and with a null in the horizontal plane at +/- 90 degrees. The simulated gain of the antenna was close to 1dBi. Although the gain might not be high, the radiation pattern showed that the transponder can be interrogated from almost any angle by the RFID reader.

C. Chipless RFID Tag Multiresonator Design

In order to encode the multi-frequency interrogation signal sent from the reader it is necessary to create a multiresonating circuit which will perform band-stop filtering of the interrogation signal and hence create the spectral signature which can be decoded by the reader after being received. The multiresonance was achieved by using multiple spiral resonators placed next to the microstrip line. The layout of the designed multiresonator circuit incorporating spiral resonators is shown in Fig. 7. Agilent's ADS2005A Momentum software was used in the design process.

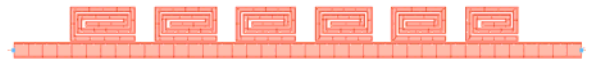

Fig. 7. Layout of the multiresonating circuit designed for the chipless RFID tag

The designed spirals use gap coupling to achieve the stop band characteristics. The gap is 0.2mm and the separation between the spirals is 3mm. The spirals vary in length which influences the resonance frequency. Each spiral contributes to a particular resonance, hence from Fig. 7 we can expect to have 6 resonances. The simulated S-parameter results obtained from ADS 2005A Momentum are presented in Fig. 8.

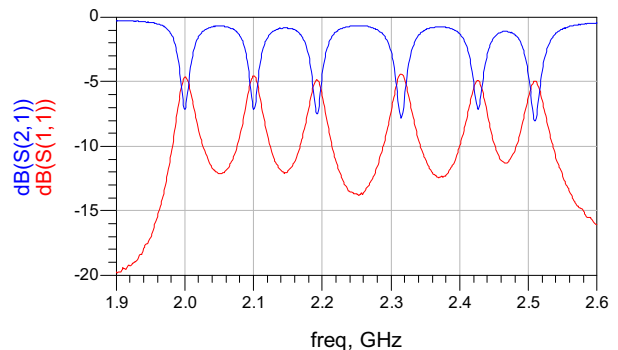

Fig. 8. Simulated S-parameter results of the multiresonator circuit for chipless RFID tag.

From Fig. 8 we can see that there are 6 resonances which can be encoded as 6 bits. The presence of the resonance will stop a particular frequency resulting in the signal being

attenuated at that frequency when retransmitted to the reader. This can be used to encode logic “0” based on amplitude levels. The absence of the resonance (which can be achieved by shorting the spiral or removing it) will be retransmitted with minimum attenuation due to the absence of the stop-band. This would represent logic “1”.

In the next section we will present a simulation of the chipless RFID system using the DSP simulator in ADS.

D. Chipless RFID System Simulation

The chipless RFID system was first simulated using the ADS2005A DSP simulator. An experimental setup containing a signal generator, reader antennas, chipless transponder and a spectrum analyzer was incorporated into the DSP simulator. The block diagram of the simulation setup is shown in Fig. 9.

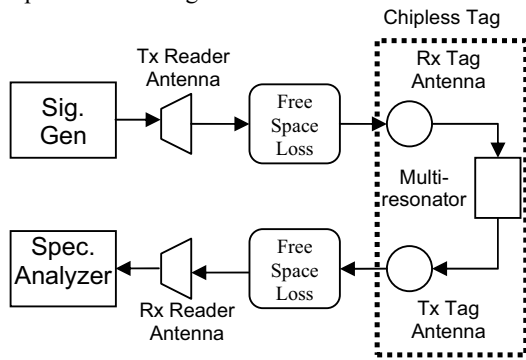

Fig. 9. Block diagram of the simulation setup of the chipless RFID system.

The signal generator provides the necessary interrogation signals in the form of a multi-frequency signal. The transponder receives the signals and processes them by attenuating certain frequencies corresponding to the resonant frequencies of the multi-resonator circuit. The signals are then retransmitted to the receiving reader antenna and shown on the spectrum analyzer. The transmitting and receiving antennas of the reader and transponder are cross-polarized in such a way that the reader’s Tx and the tag’s Rx antenna are vertically polarized and the reader’s Rx and the tag’s Tx antenna are horizontally polarized. This is necessary in order to minimize the influence of the interrogation signal of the reader on the tag’s transmitted signal.

We simulated the system reading two transponders; the first one was encoded with the ID 010101 and the second one was encoded with the ID 101000. Logic ‘0’ bit corresponds to the tag’s multi-resonator resonating at the particular frequency and logic ‘1’ represents the absence of resonance at a particular frequency. The tag has a 6 bit ID where the MSB corresponds to the highest resonant frequency at 2.5GHz and the LSB corresponds to the lowest resonant frequency at 2GHz. The resonances are

approximately 100MHz away from each other. The multifrequency interrogation signal is shown in Fig. 10 and the responses of the first and second tag are shown in Fig. 11 and Fig.12 respectively.

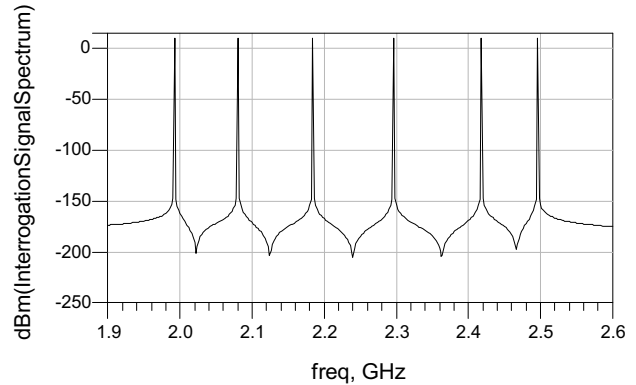

Fig. 10. Simulated multifrequency interrogation signal (EIRP of 10dBm for every frequency)

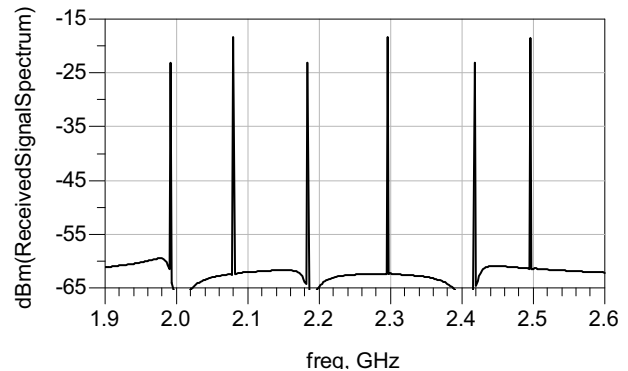

Fig. 11. Received signal from chipless transponder with ID 010101.

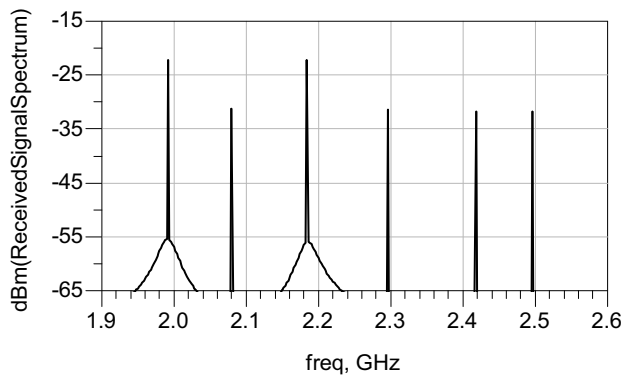

Fig. 12. Received signal from chipless transponder with ID 101000.

As can be seen from Fig. 11 and Fig. 12 the amplitude of the interrogation signal is modified by the multi-resonator and retransmitted back to the reader’s receiving antenna where the unique spectral signature of the two tags can be extracted. It is clear that the presence of a resonance introduces a 5-7dB difference in comparison to when there is no resonance. In this simulation we only observed the

spectral signature in terms of amplitude variation. Future works will be concentrated on investigating the phase of the retransmitted signal.

III. MEASURED RESULTS AND CHIPLESS TAG FIELD TRIALS

In this section we will present the measured results of the designed tag antennas and multiresonator circuit alongside with the chipless RFID proof of concept experiment which proves that this RFID system works the way we intended it to work.

A. Chipless RFID Tag Antenna Measurements

The chipless RFID tag has a UWB monopole antenna for data transmission and reception due to its wide-band characteristics (necessary for the system to operate) and its radiation pattern (very close to omni directional). The photograph of the manufactured monopole antenna is shown in Fig. 13.

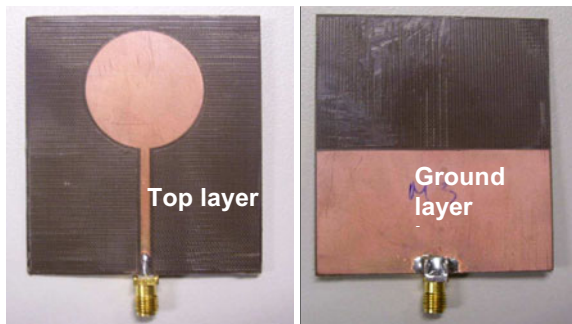

Fig. 13. Photograph of the manufactured UWB monopole

The monopole was etched on Taconic TLX-0 substrate and the measured return loss showed adequate antenna performance for the desired and designed frequency band of 2GHz to 2.5GHz as shown in Fig. 14. The radiation pattern was also measured at 2GHz and 2.5GHz in the vertical and horizontal plane and is plotted on graphs shown in Fig. 15 and 16 respectively. The measured antenna gain was 0dBi.

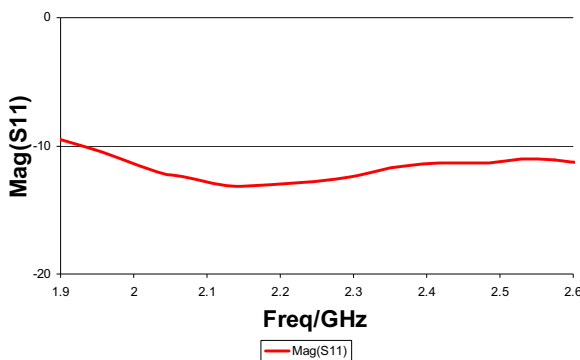

Fig. 14. Measured return loss of the chipless RFID tag antenna.

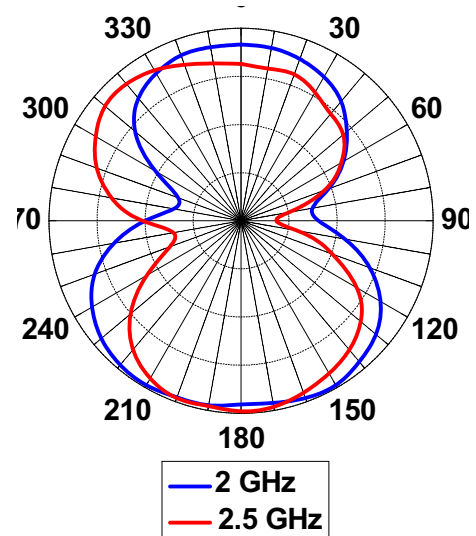

Fig. 15. Measured monopole antenna radiation pattern in the vertical plane at 2GHz and 2.5GHz.

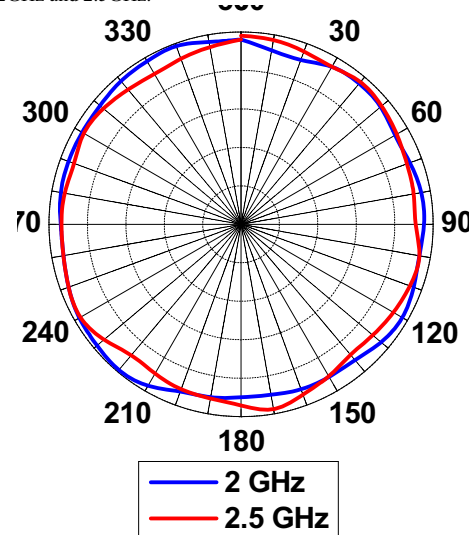

Fig. 16. Measured monopole antenna radiation pattern in the horizontal plane at 2GHz and 2.5GHz.

It is important to mention that the antenna radiation pattern and gain measurements were performed in a laboratory and not anechoic chamber hence these results can be taken as results in real-life operating conditions and environment.

B. Chipless RFID Tag Multiresonator Measurements

The multiresonator was designed on Taconic TLX-0 substrate as well. The photograph of the multiresonator circuit with spiral resonators is shown in Fig. 17.



Fig. 17. Photograph of the manufactured multiresonator with spiral resonators.

The 2-port S-parameters were measured using Agilent's PNAE8361A. They are presented in Fig. 18.

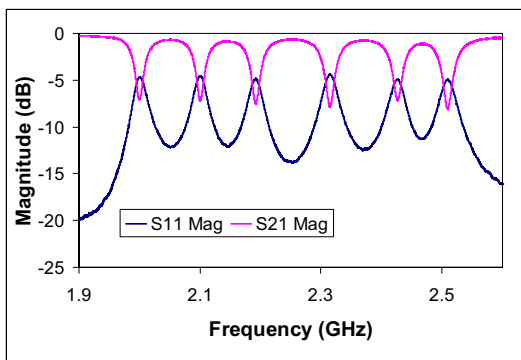

Fig. 18. Measured S-parameters of the manufactured multiresonator.

It was necessary to encode data into the transponder thus giving it a unique ID. This can be done by introducing or removing the resonances of the multiresonator. In Fig. 18 we see the S-parameter measurements of a multiresonator which gives a tag ID of 000000. In order to create a different ID, for example, 010101 the resonances at 2.1GHz, 2.3GHz and 2.5GHz need to be removed. By removing the spiral or shorting it between successive turns the influence of the spiral can be neutralized and the resonance thus removed. In Fig. 19 and Fig. 20 we show the S-parameter measurements of the multiresonators which give unique IDs; 010101 and 010111.

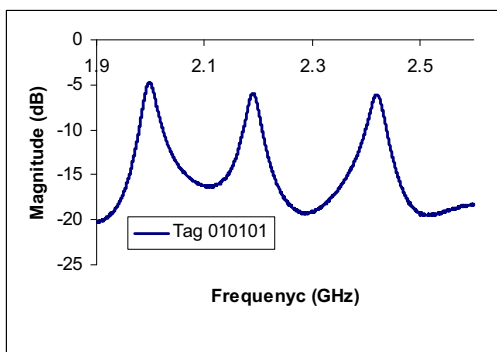

Fig. 19. Measured S11 of multiresonator with spectral signature "010101".

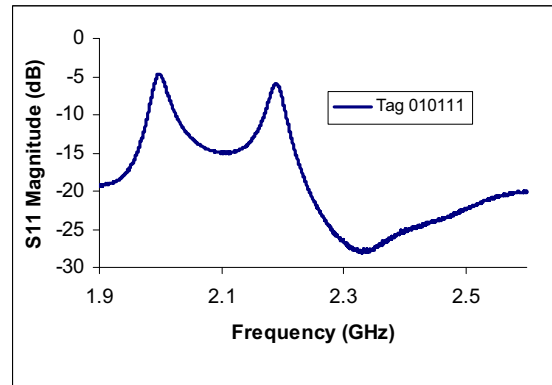

Fig. 20. Multiresonator with spectral signature "010111".

C. Chipless RFID Tag Field Trials

In order to prove the concept of this novel chipless RFID system it was necessary to setup the experiment. We used used dipole antennas with a reflective shield where the antennas were cross polarized again. The block diagram and photograph of the experimental setup are shown in Fig. 21 and 22 respectively. The reader antennas were separated at 13cm and the tag was 10cm away from both antennas as well, the transmitting power being 10dBm. The dipole antennas were more directive than the UWB monopoles (Fig. 23 and Fig. 24) and had a measured gain of 5dBi.

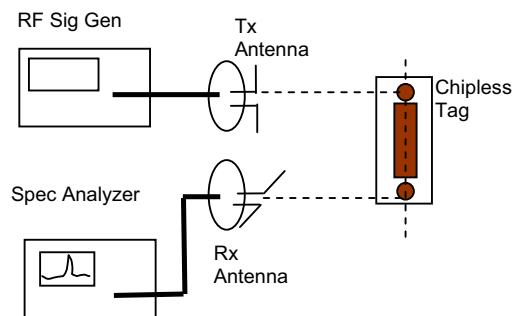

Fig. 21. Block diagram of the experimental setup using directive dipoles as reader antennas

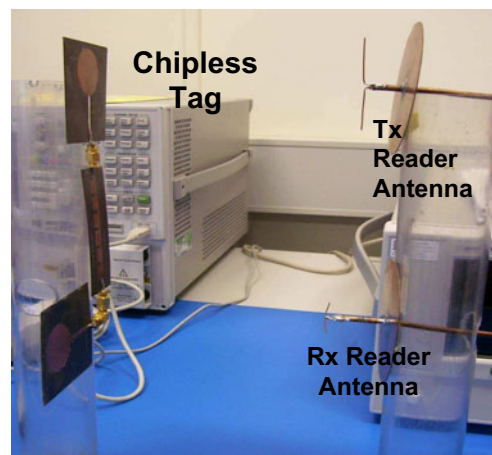

Fig. 22. Photograph of the experimental setup using directive dipoles.

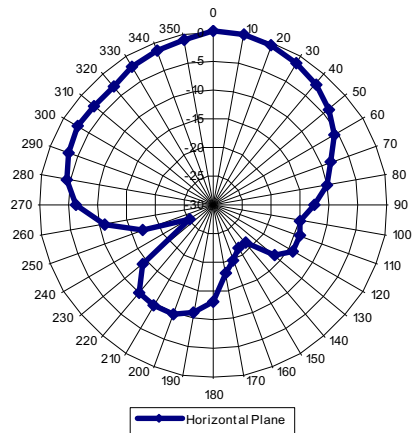

Fig. 23. Reader antenna radiation pater – horizontal plane.

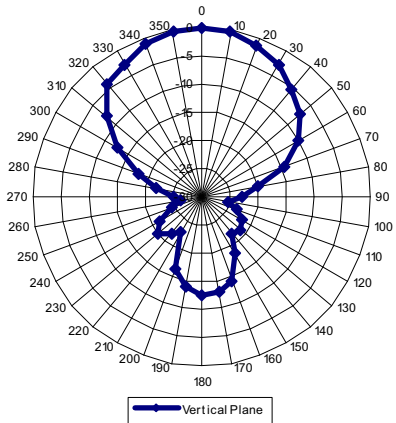

Fig. 24. Reader antenna radiation pater – vertical plane.

The reader antennas operated at a frequency range of only 160MHz (from 2.37GHz to 2.53GHz) as can be seen in Fig. 25. This means that we can only interrogate the two highest frequencies of the spectral signature; at 2.42GHz and 2.5GHz.

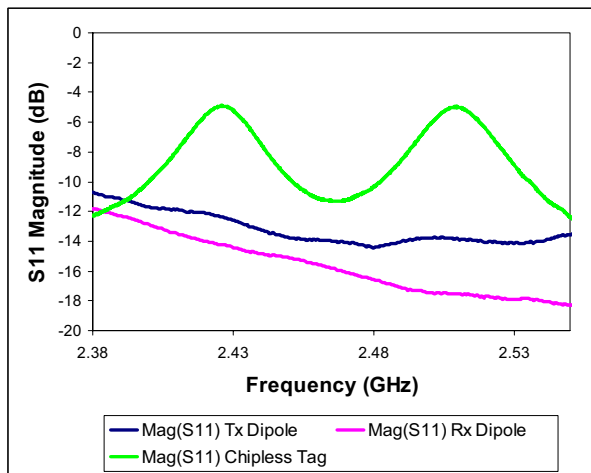

Fig. 25. Measured return loss of the reader dipoles (blue and pink) and the resonance of the multiresonator (black).

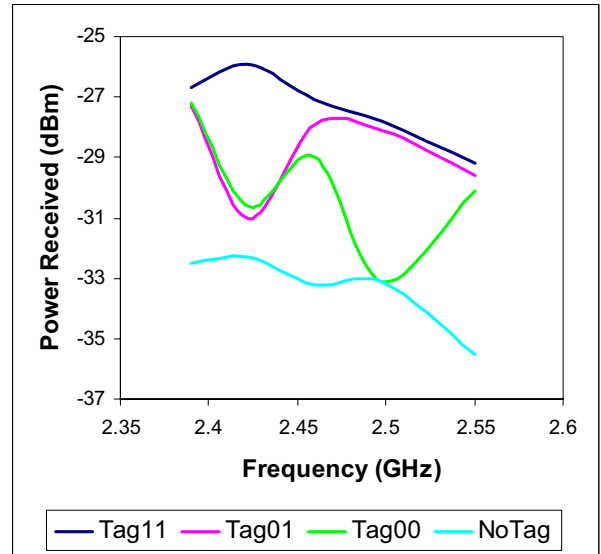

Fig 26 Measured Response of the chipless Tag encoded with 00, 10 and 11 and No Tag with separation between Tx antenna and Tag is 13cm, Rx antenna to Tag 10.5cm and transmitter power 12dBm.

We encoded 3 tags with ID's 00, 01 and 11. The measured results show the received power levels from the three transponders and when there is no tag in the reading zone (Fig. 26). The highest power levels were received for Tag11 and clear dips in the received power (due to resonances in multiresonator) were present with tags encoded with Ids 01 and 00. The lowest power level was achieved when no tags were in the interrogation, due to the cross-polarization of the reader antennas. The photograph of the prototype tag is shown in Fig. 27.

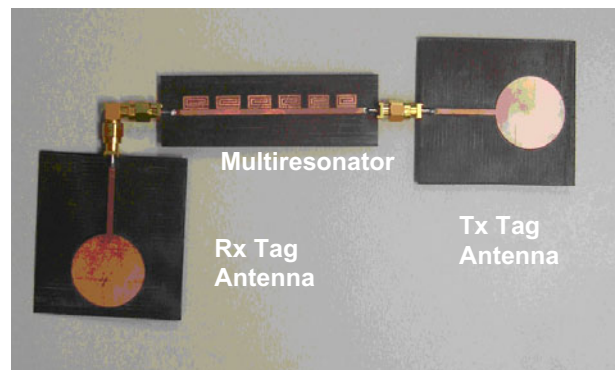

Fig. 27. Photograph of prototype chipless RFID Tag

IV. CONCLUSION

In this paper we have presented a novel chipless RFID system which can be used for barcode replacement. The operating system uses multiresonators to encode data into the spectral signature. By interrogating the transponder by a multi frequency signal it is possible to extract the spectrum

power density and decode the transponders ID. We have shown simulation and experimental results which confirm that our system works. It represents a cheap and economical way of potentially replacing the barcode due to the fact that the chipless transponders do not comprise of any silicium based circuits or semi-conductors hence they are fully planar.

Future works will be concentrated on improving the resonators as well as investigating the phase of the received signal encoded by the tag due to the fact that phase is more resistive to effects of noise and other interferences.

REFERENCES

- [1] J. Landt, Shrouds of Time. The History of RFID, AIM Inc. publications, October 2001
<http://www.aimglobal.org/technologies/rfid/resources/shrouds_of_time.pdf> (accessed March 2006)
- [2] H. Stockman, "Communication by Means of Reflected Power", Proceedings of the IRE, pp: 1196-1204, October 1948.
- [3] D. McFarlane, Y. Sheffi, The Impact of Automatic Identification on Supply Chain Operations, *International Journal of Logistics Management*, vol. 14, no. 1, 2003.
- [4] M. Karkkainen, T. Ala-Risku, Automatic Identification – Applications and Technologies, *Logistics Research Network 8th Annual Conference*, London UK, September 2003.
- [5] K. Finkenzeller, *RFID Handbook 2nd Edition*, John Wiley & Sons, Ltd., 2003.
- [6] D'Hont S., "The Cutting Edge of RFID Technology and Applications for Manufacturing and Distribution", Texas Instruments white paper, <http://www.ti.com/rfid/docs/manuals/whtPapers/manuf_dist.pdf> (accessed March 2006)
- [7] L. Reindl, G. Scholl, T. Ostertag, H. Scherr, U. Wolff, F. Schmidt, Theory and Application of Passive SAW Radio Transponders as Sensors, *IEEE Transactions on Ultrasonics, Ferroelectrics and Frequency Control*, 45(5), pp.1281-92, ISSN 0885-3010.
- [8] C. S. Hartmann, P. Brown, J. Bellamy, Design of Global SAW RFID Tag Devices, Reprint from Proceedings of the Second International Symposium of Acoustic Wave Devices for Future Mobile Communication Systems, Chiba University, Japan, March 2004.
- [9] C. S. Hartmann, A Global SAW ID Tag with Large Data Capacity, Reprint form Proceedings of 2002 IEEE Ultrasonics Symposium, Munich, Germany, October, 2002.