



26th CIRP Design Conference

Design evaluation of automated manufacturing processes based on complexity of control logic

Bugra Alkan*, Daniel Vera, Mussawar Ahmad, Bilal Ahmad, Robert Harrison

*Automation Systems Group, WMG, University of Warwick, CV4 7AL, Coventry, West Midlands, UK** Corresponding author. Tel.: +44 (0)7786360026. E-mail address: B.Alkan@warwick.ac.uk

Abstract

Complexity continues to be a challenge in manufacturing systems, resulting in ever-inflating costs, operational issues and increased lead times to product realisation. Assessing complexity realizes the reduction and management of complexity sources which contributes to lowering associated engineering costs and time, improves productivity and increases profitability. This paper proposes an approach for evaluating the design of automated manufacturing processes based on the structural complexity of the control logic. Six complexity indices are introduced and formulated: Coupling, Restrictiveness, Diameter, Branching, Centralization, and Uncertainty. An overall Logical Complexity Index (CL) which combines all of these indices is developed and demonstrated using a simple pick and place automation process. The results indicate that the proposed approach can help design automation logics with the least complexity and compare alternatives that meet the requirements during initial design stages.

© 2016 The Authors. Published by Elsevier B.V. This is an open access article under the CC BY-NC-ND license (<http://creativecommons.org/licenses/by-nc-nd/4.0/>).

Peer-review under responsibility of the organizing committee of the 26th CIRP Design Conference

Keywords: Process modelling; design efficiency; complexity indicator; complexity management.

1. Introduction

Manufacturing enterprises are challenged to constantly improve their production systems in terms of flexibility, reliability and responsiveness to satisfy customer demands for products with better features, unique functions and shorten product lifecycles [1]. To meet production targets of complex products with higher quality requirements and reduced time to market, the manufacturing industry is commissioning highly automated production systems, numerous sub-systems of various nature, including machining and processing systems, material handling devices and material storage and retrieval units [2] as well as more agile and responsive methods and strategies. According to ElMaraghy et al. [3], these changes have increased the complexity of manufacturing enterprises, all the way down to the shop floors.

An increase in complexity was reported to negatively impact all aspects of manufacturing, in terms of: production quality, reliability, throughput and production time at both operation, maintenance and organisational levels [3]. Although a significant number of academic studies have focused on analysing complexity of manufacturing processes and systems, there is still a crucial lack of understanding of both the nature

and sources of complexity as well as the correlation between complexity and performance parameters, such as: productivity, flexibility and responsiveness [4]. A diagram summarizing the complexity issue within the manufacturing is illustrated in Figure 1.

Manufacturing processes become significantly complex as the product variety and the required functionality increase [5]. Complex automation processes are difficult to modify, change and maintain. In order to improve the quality of the automation processes, complexity should be minimized without losing the required functionality. In this paper, control logic of automated manufacturing processes is modelled as a component-based network in which a set of components cooperates together to achieve the common objective. A quantitative approach is proposed which produces measurable complexity indices based on the structural properties of the control logic. These indices are used to evaluate structural complexity of design alternatives and identify potential bottlenecks at an initial stage.

2. Literature review

Complexity phenomena in the manufacturing domain are becoming a popular research topic. In complex systems, small

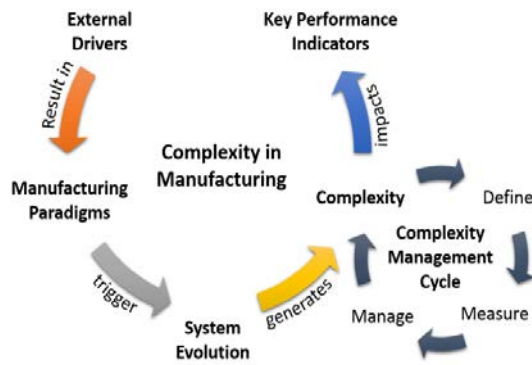

Fig. 1. Complexity in manufacturing domain

changes in initial conditions may lead to significant variations of the system's response, thus, complex systems may be very problematic to operate, control and maintain, and prediction of the behaviour of such systems are often impractical [2]. In the literature, complexity in manufacturing is defined within two domains: i.e. physical and functional [6]. Complexity in physical domain can be classified as static and dynamic [7]. Static (or structural) complexity represents internal and time independent characteristics of a system and focuses on interconnectivity between sub-systems or sub-modules [8]. The characterisation of dynamic (or operational) complexity focuses on operational characteristics of the system and its unpredictability over a time interval [9]. In a similar vein to the physical domain, Suh promoted an original approach to describe complexity in the functional domain, which can also be classified into two sub-groups, namely: time independent and time dependent [10]. According to this, complexity is used to represent emerged ambiguity while system is performing predetermined tasks under functional requirements.

In the last two decades, several approaches in measuring complexity of both manufacturing systems and processes have been offered. In this paper, approaches for complexity assessment have been categorized into four main groups (i.e. information theoretic measures, chaos and non-linear dynamics theory, heuristics/indices based metrics and hybrid measures). Information theoretic approaches offer an objective measure to identify and assess cause effect relationships. These measures have an ability to integrate systemic characteristics in a single measure and offer numerous advantages such as: adaptability to different types of systems, flexibility and ability to compare systems [11]. Nevertheless, information theoretic complexity measures can be seen as lack of, or insufficiently detailed practical methodology for applying into real case studies. Issues to be addressed include the impact of imperfect information, cost of the measurements, or conversion of the results into informative data and recommendations for generic and specific issues on system design and management.

Chaos theory provides a robust theoretical framework for understanding non-linearity, uncertainty and instability, and it is considered as a well-established science. However, some limitations bound back this approach. As highlighted in [12], existence of chaos in manufacturing has not been completely verified yet. In addition to this, manufacturing systems may

exhibit stochastic events as well as chaotic behaviours. However, tools and methods developed based on theory of chaos and non-linear dynamics are not able to capture such events [13]. Furthermore, methods used for accurate estimation of the Lyapunov exponents require huge data sets and they are highly sensitive to variations in the input parameters [13].

Heuristic/indices based metrics are experience based methods which are used because of their effort saving characteristics when the true solution of a problem is impractical and/or time consuming to reach or converge. The heuristics based assessment approaches generally are used to find solutions for a specific focus or type of system (e.g. flexible manufacturing systems). These approaches can be considered a valuable tool to compare initial designs with possible alternatives. Although heuristics based measures are often used due to their ease of use, it is debatable as to whether these measures reflect overall system complexity accurately [3]. Also, the applicability of heuristics based approaches over different types of systems is often limited. Drawn from the limitations described above, a hybrid complexity model is proposed to assess structural complexity of automation control logics.

3. Modelling of an automation process control logic

In this paper, a method that combines finite state machines (FSM) and petri nets approaches, to model the control logic of automated manufacturing processes is introduced. In this approach, each automation field device has an abstract definition of its generic behavior represented by a state-transition diagram (STD) composed of constant number of states and transitions. These abstract definitions are not tied-in any specific application [14]. In STDs, states are connected to each other through transitions governed by sequence interlock conditions [15]. Instead of decomposing a given automation process from top to down, a process can be synthesised from bottom to up by designing STDs for individual system's components (e.g. sensors, actuators) and then connecting them in a way that enables them to cooperate and to achieve a common objective [16]. The connection between components is often called as interlocking or logically coupling the distributed STDs together to generate the system behaviours. In this approach, a system can be expressed mathematically as follows;

$$system = \{S, S_i, T, C\} \quad (1)$$

where: S is the set of all possible states in the STD, T is the set of all possible transitions in the STD, S_i is the initial state of each component's STD and C is the set of conditions that triggers the transitions. As an example, a STD describing the control behaviour of a simple feeding system control logic is given in Figure 2. This system includes three components. The feeder component can only exist in either one of two states ("RETRACTED" and "EXTENDED") connected by transitions ("RETRACTING" and "EXTENDING"). The directed black links represents the internal conditions. External conditions associated with a STD can be defined as the logical combinations (logical "AND" and "OR") of states of other

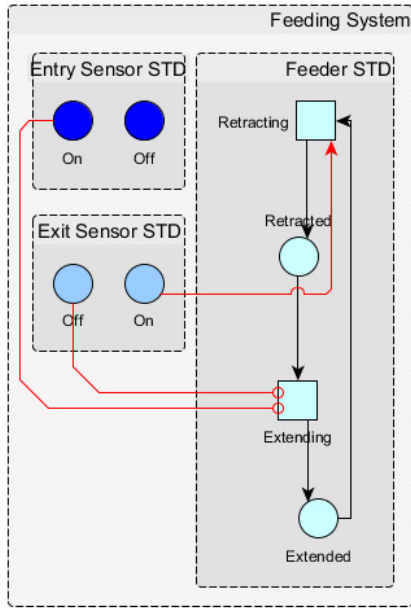

Fig. 2. Control logic state-transition diagrams and interlocks

components. The external conditions are represented by red links and marked with an arrow or circle depends on the logical combination. Arrows represent the “AND” condition, whereas circles represent the “OR” condition. During execution, each component evaluates the transitions associated with the current state to determine whether the external conditions are satisfied for it to proceed to the next state [16]. As an example, the feeder proceeds from “RETRACTED” state to “EXTENDED” state via firing the “EXTENDING” transition which requires at least one of the two states (*Entry Sensor=ON or Exit Sensor=OFF*) satisfied.

4. Assessing complexity of an automation control logic

Structural complexity of automation control logic affects overall performance of the system. Highly complex automation logics often require a time-consuming programming phase, longer state checking times and relatively high computing power. Moreover, increased complexity in automation logic makes processes harder to diagnose and maintain. In this section, the Logical Complexity Index (C_L) composed of six indices is introduced to be able to objectively evaluate structural complexity of control logic and compare differences among alternative structures. Overall C_L score is calculated by Eq. 2.

$$C_L = [\sum_{i=1}^n (c_i^*)^2] / n \quad (2)$$

where: c_i^* is the normalized value of each complexity index and n is the number of total complexity indices. Complexity indices used in the C_L are described in the following sections.

4.1. Coupling Index, c_c^*

The coupling index chiefly developed by [17] focuses on two essential components of a typical connected structure (i.e.

number of elements and the interrelation between these elements). The coupling index is calculated by Eq. 3.

$$c_c^* = 1 - \frac{N}{\sum_{i=1}^N N_i} \quad (3)$$

where: N is the total number of states and transitions and N_i is the total number of states and transitions directly connected to the state or transition “ i ”. Higher scores of coupling index is indicative of a more complex logic.

4.2. Restrictiveness Index, c_r^*

Restrictiveness estimator developed by [18] represents the ratio between number of existing direct and indirect precedence relations and the theoretical maximum number of direct and indirect relations. Restrictiveness index is calculated by Eq. 4.

$$c_r^* = \frac{2\sum r_{ij} - 6(N-1)}{(N-2)(N-3)} \quad (4)$$

where: r_{ij} is a reachability indicator, such that:

$$r_{ij} = \begin{cases} 1 & \text{if there is a path from element } i \text{ to } j \\ 0 & \text{if there is not a path from element } i \text{ to } j \end{cases} \quad (5)$$

Restrictiveness index varies between zero and one. High values represent serial operations, whereas low values indicates parallelism.

4.3. Diameter Index, c_d^*

Diameter index proposed by [19] is the longest shortest path between inputs and outputs of an automation sequence. That is, if the length of the shortest path between input i and output j is D_{ij} , then the diameter index of the automation sequence can be calculated by Eq. 6.

$$c_d^* = 1 - \frac{1}{e^{0.05(\max_{ij}(D_{ij}))}} \quad (6)$$

In this paper, diameter index is referred as the operation size, higher scores mean longer operations.

4.4. Branching Index, c_x^*

Branching in an automation sequence is measured by means of cyclomatic number developed by [20]. Cyclomatic number is a widely used software metric to analyse complexity of control flows. In this paper, this metric is used to analyse decisional complexity of an automation sequence. Branching index is calculated by Eq. 7.

$$c_x^* = 1 - \frac{1}{e^{0.05(|N_L| - |N_S| - |N_T| + 2)}} \quad (7)$$

where: N_S is the total number of states, N_T is the total number of transitions and N_L is the total number of internal and external conditions.

4.5. Centralization Index, c_s^*

As the process becomes centralized, changing or modifying its structure becomes difficult. Therefore, centralization index developed by [19] is used to capture the degree of centralization

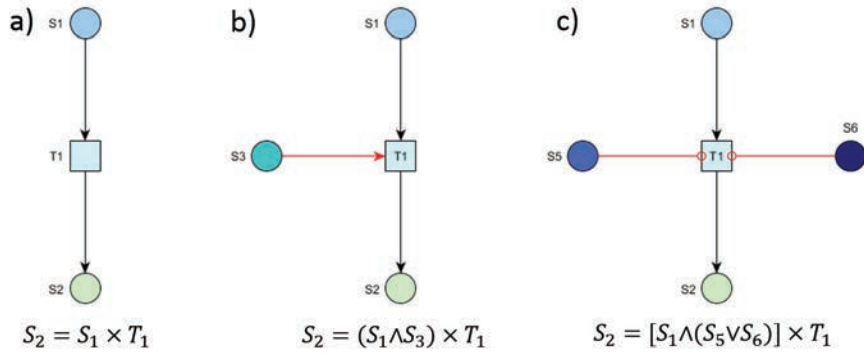

Fig. 3. Algebraic representation of transitions

for a given sequence of operation. Centralization index is calculated by Eq. 8.

$$c_s^* = \frac{1}{(N-1)(V(k)-1)} \sum_{i=1}^N (V(k) - V(i)) \quad (8)$$

where: $V(i)$ is the total number of input and output links of the i_{th} element and $V(k)$ is the maximum value of $V(i)$ in the sequence. c_s^* can obtain two limited values: i.e. $c_s^* = 1$ in case that the structure is centralized to the maximum degree, $c_s^* = 0$ in case that the structure is decentralized to the maximum degree.

4.6. Uncertainty Index, c_u^*

Uncertainty index investigates the probability of completion of an automation cycle. Operational characteristics of an automated system are heavily influenced by structural properties of its logic. Automations with a complex logic (e.g. highly connected) are more fragile to input fluctuations (e.g. functionality changes, modifications, etc.). Uncertainty index relates structural complexity of a given sequence to its operational uncertainty caused by internal disturbances such as component failures. The proposed index calculates the difference in time to reach the theoretical maximum uncertainty between states with and without external component conditions. It is hypothesised that if the time required to reach the maximum entropy for a state deviates from its isolated form, the state is suffering from the structural complexity. Thus the efficiency of the design should be penalized. Uncertainty Index c_u^* is calculated by Eq. 9.

$$c_u^* = \frac{\sum_1^{N_s} (1 - \frac{T_{design,i}}{T_{isolated,i}})}{N_s} \quad (9)$$

where: N_s is the total number of states (not including transitions), $T_{isolated,i}$ is a theoretical time to reach the maximum uncertainty for component state i as it is isolated from external conditions and $T_{design,i}$ is a theoretical time to reach the maximum uncertainty for component state i as it is interlocked with other components in a logical order.

In order to calculate the theoretical time, the probability to reaching a state in an automation cycle is modelled using an algebraic representation. In this representation, interlock conditions are represented by binary operators \wedge (AND) and \vee (OR) and transitions between successive states are denoted by

a multiplication operator (\times). It is assumed that each state and transition event can be either completed or not completed. Hence, the probability of completion of a state is described as a function of the probability of completion of predecessor transition and probability of completion of the conditions that need to trigger that transition. Figure 3 shows three transitions having different execution conditions. In Figure 3a, the probability of completion of State 2 (S_2) depends on the probability of completion of State 1 (S_1) and the probability of completion of Transition 1 (T_1). Therefore, probabilities of completion of this state is calculated by multiplying the probability of completion of condition and transition, as follows (Eq. 10);

$$S_2 = S_1 \times T_1 = S_1 T_1 \quad (10)$$

Figure 3b describes a state transition that requires an external condition (AND) to proceed. In such cases, the condition that has the lowest probability of completion among all conditions linked with "AND" logic, is multiplied with the success rate of the associated transition in order to calculate the probability of completion of successive states. The function of the binary operator \wedge (AND) is described by Eq. 11.

$$S_2 = (S_1 \wedge S_3) \times T_1 = [\min(S_1, S_3)] T_1 \quad (11)$$

In cases where the transitions is executed with OR logic, the condition with the maximum probability of completion is selected. For example, the probability of occurrence of State 2 in Figure 3c is calculated as follows;

$$S_2 = [(S_1 \wedge (S_5 \vee S_6))] \times T_1 = [\min(S_1, \max(S_5, S_6))] T_1 \quad (12)$$

Once the whole system is described by the proposed algebraic representation, the probability of completion of each state with respect to the conditions of its predecessor conditions can be found. In this research, the probability of completion of all system inputs and all transitions are assumed to be independent from other system activities and equal to the corresponding component's reliability. They are calculated as follows;

$$S_{initial,k} = T_{i,k} = e^{\frac{-t_k}{MTBF_k}} \quad (13)$$

where: $S_{initial,k}$ is the input state of component k (only valid if the state does not have any predecessor state and is an input state for the system), $T_{i,k}$ is the i_{th} transition of component k , t_k

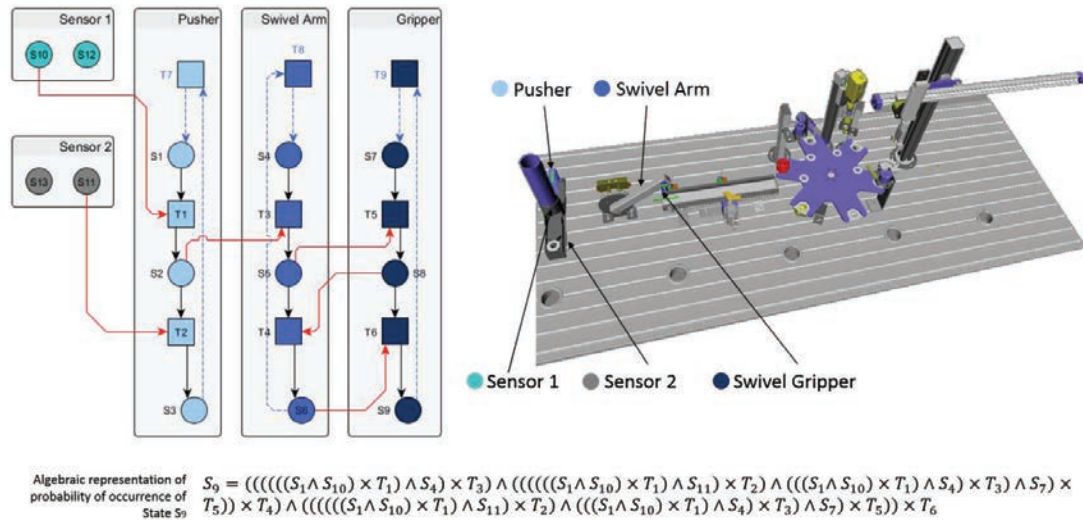

Fig. 4. Selected pick and place operation: station CAD geometry, the sequence of operation and algebraic representation of the output state S_9

is the k_{th} component service time, and $MTBF_k$ is the mean time between failure of component k . Hence, time-dependent uncertainty of a component state H_k , can be computed using Shannon’s information entropy formulation [21] described as follows;

$$H_k = - \sum_{i=1}^2 S_i \log S_i \tag{14}$$

where: S_i is the probability of completion of the component state and i is the events i.e. completed or not completed. The inflection point of time-dependent uncertainty of a component state with respect to its service time is the maximum uncertainty point, and the time required to reach this point are $T_{design,i}$ and $T_{isolated,i}$ for non-isolated and isolated components, respectively. The proposed uncertainty index has a range between 0 and 1. To reduce unpredictability of a process due to its complexity, interdependency between components should be minimized and critical components should have high reliability.

5. Use case

The developed Logical Complexity Index (C_L) is applied to an automatic pick and place process to assess its logical complexity. A Festo table size test system (Fig. 4) was modelled in a virtual process planning and simulation environment. The part of the system used as case study consists of three actuators and two sensors. The STD describing the control logic is composed of a total of eleven states, six transitions and seven sequence interlock conditions. Only the automated (auto-mode) sequence was considered in the calculations (i.e. no re-initialization or manual sequence). The process consists in picking small cylinders from pusher magazine and placing them onto a conveyor using a pick and place swivel arm and suction. The process consists of following steps;

- Sensor 1 checks the status of the magazine (i.e. empty or full),

- Pusher pushes a cylinder part to the picking location,
- Sensor 2 detects part presence at pick location,
- Swivel arm moves to picking location,
- Vacuum gripper mounted on the swivel arm picks the part,
- Sensor 2 checks the status of picking location (i.e. empty or full),
- Pusher moves to home position,
- Swivel arm moves to conveyor location and,
- Vacuum gripper releases the part on the conveyor.

Table 1 shows the states and transitions, and the assumed mean time between failures rates of each component used in the process.

Table 1. Component’s state-transition information and MTBF values

Component	State-Transition	Description	
Pusher (MTBF: 45000 hrs)	S1	Retracted	
	S2	Extended	
	S3	Retracted Finished	
	T1	Extending	
	T2	Retracting	
	T7	Re-initialization	
	Swivel Arm (MTBF: 60000 hrs)	S4	At Conveyor Position
		S5	At Pick Position
		S6	At Conveyor Finished
T3		Moving to Pick Position	
T4		Moving to Conveyor Position	
Gripper (MTBF: 100000 hrs)	T8	Re-initialization	
	S7	At Release Position	
	S8	Part Gripped	
	S9	Part Released	
	T5	Gripping Part	
	T6	Releasing Part	
	T9	Re-initialization	
	Sensor 1 (MTBF: 250000 hrs)	S10	True
		S12	False
Sensor 2 (MTBF: 40000 hrs)	S11	False	
	S13	True	

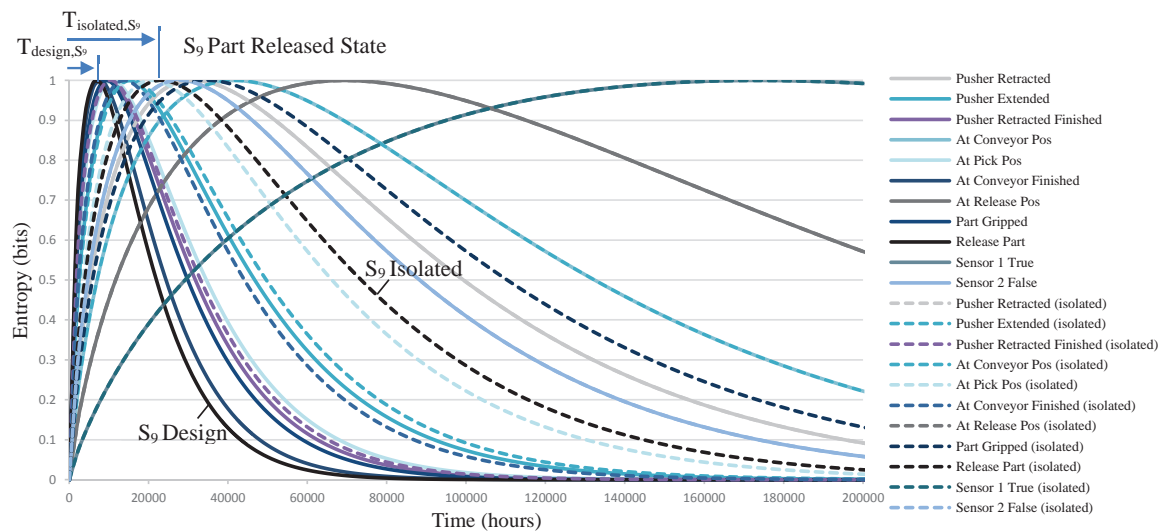

Fig. 5. Uncertainty index calculation

According to the results, a C_L score is recorded as 0.1354 which indicates the control logic is simple and design is valid. The individual complexity indices are recorded as: coupling: 0.0808, restrictiveness: 0.5619, diameter: 0.3296, branching: 0.1392, centralization: 0.5625 and uncertainty: 0.2149. This result aligns with the engineering intuition i.e. a simple process executed by a few simple components. Accordingly, the process reaches the theoretical maximum uncertainty averagely 21.49% faster due to its logical coupling. Moreover, logical dependencies of each component are found as follows: Gripper (47.82%), Swivel arm (30.85%), Pusher (0.13%), Sensor 1 (0.0%), and Sensor 2 (0.0%). Time-dependent entropy scores for each state is illustrated in Figure 5.

6. Conclusion

In this paper, an objective approach for evaluation of automated manufacturing process designs based on structural complexity of the automation control logic was developed. Six complexity indices which capture structural properties of the logic were defined and formulated. The introduced indices are useful at the early design stages when designing the automation logic, and reducing coupling and redundancies. The individual complexity indices are combined into a single complexity Logical Complexity Index (C_L). The developed model aims at providing support for automation systems' engineers in the earliest possible phases of the system design and engineering. Future work will focus on implementing design support functionalities based on the presented model, which will be integrated in a virtual process planning and simulation solution, namely the vueOne virtual developed by WMG, university of Warwick and used in this research to model the process of the system used as case study.

Acknowledgment

The authors gratefully acknowledge the support for this work from UK EPSRC, through the Knowledge-Driven Configurable Manufacturing (KDCM) research project.

References

- [1] Zhang T, Efstathiou J. The complexity of mass customization systems under different inventory strategies. *Int J Comput Integr Manuf* 2006;19:423–33.
- [2] Cho S, Alamoudi R, Asfour S. Interaction-based complexity measure of manufacturing systems using information entropy. *Int J Comput Integr Manuf* 2009;22:909–22.
- [3] Elmaraghy W, Elmaraghy H, Tomiyama T, Monostori L. Complexity in engineering design and manufacturing. *CIRP Ann - Manuf Technol* 2012;61:793–814.
- [4] Efstathiou J, Calinescu A, Blackburn G. A web-based expert system to assess the complexity of manufacturing organizations. *Robot Comput Integr Manuf* 2002;18:305–11.
- [5] Modrak V, Marton D. Configuration complexity assessment of convergent supply chain systems. *Int J Gen Syst* 2014;37–41.
- [6] Chryssolouris G, Efthymiou K, Papakostas N, Mourtzis D, Pagoropoulos A. Flexibility and complexity: is it a trade-off? *Int J Prod Res* 2013;51:6788–802.
- [7] Frizelle G, Woodcock E. Measuring complexity as an aid to developing operational strategy. *Int J Oper Prod Manag* 1995;15:26–39.
- [8] Deshmukh A V, Talavage JJ, Barash MM. Complexity in Manufacturing Systems Part 1: Analysis of Static Complexity 1 Introduction. *IEE Trans* 1998;30:645–55.
- [9] Espinoza V, ElMaraghy H, AlGeddawy T, Samy SN. Assessing the structural complexity of manufacturing systems layout. *Proc 4th CIRP Conf Assem Technol Syst* 2012:65–70.
- [10] Suh N. Complexity: theory and applications 2005.
- [11] Calinescu A. Manufacturing Complexity: An Integrative Information-Theoretic Approach 2002.
- [12] Efthymiou K, Pagoropoulos a., Papakostas N, Mourtzis D, Chryssolouris G. Manufacturing systems complexity review: Challenges and outlook. *Procedia CIRP* 2012;3:644–9.
- [13] Efthymiou K. On the assessment of manufacturing systems complexity. University of Patras, 2013.
- [14] Harrison R, Lee SM, West AA. Lifecycle engineering of modular automated machines. *2nd IEEE Int Conf Ind Informatics, INDIN'04* 2004:501–6.
- [15] Lee SM, Harrison R, West a a. A component-based control system for agile manufacturing. *Proc Inst Mech Eng Part B J Eng Manuf* 2005;219:123–35.
- [16] Harrison, R., Lee, S. M., Ong, M. H., & West AA. Distributed engineering of modular reconfigurable automation systems. *Inf Control Probl Manuf* 2006;12:553–8.
- [17] Maksimović R, Petrović S. Complexity of production structures. *Facta Univ Mech Eng* 2009;7:119–36.
- [18] Mastor A a. An Experimental Investigation and Comparative Evaluation of Production Line Balancing Techniques. *Manage Sci* 1970;16:728–46.
- [19] Modrak V. Business Process Improvement through Optimization of its Structural Properties. *Work Handb* 2005:75–90.
- [20] McCabe TJ. A Complexity Measure. *IEEE Trans Softw Eng* 1976;SE-2.
- [21] Shannon CE. A mathematical theory of communication. *ACM SIGMOBILE Mob Comput Commun Rev* 2001;5:3.