

Lesley University

DigitalCommons@Lesley

Mindfulness Studies Theses

Graduate School of Arts and Social Sciences
(GSASS)

Winter 1-15-2021

Servant Leadership as Organizational Mindfulness

Cia Kozak
ckozak2@lesley.edu

Follow this and additional works at: https://digitalcommons.lesley.edu/mindfulness_theses



Part of the [Social and Behavioral Sciences Commons](#)

Recommended Citation

Kozak, Cia, "Servant Leadership as Organizational Mindfulness" (2021). *Mindfulness Studies Theses*. 43.
https://digitalcommons.lesley.edu/mindfulness_theses/43

This Thesis is brought to you for free and open access by the Graduate School of Arts and Social Sciences (GSASS) at DigitalCommons@Lesley. It has been accepted for inclusion in Mindfulness Studies Theses by an authorized administrator of DigitalCommons@Lesley. For more information, please contact digitalcommons@lesley.edu, cvrattos@lesley.edu.

Servant Leadership as Organizational Mindfulness

December 2020

Cia Kozak

Lesley University

Dr. Melissa Jean

Dr. Andrew Olendzki

Abstract

Servant leadership exemplifies mindfulness precepts in a systems environment. Robert K. Greenleaf's (1970/2008) servant leadership movement launched with his seminal essay, *The Servant as Leader*, in which he revealed an affinity with the philosophy of mindfulness. There is a commonality of language and behaviors that servant leadership shares with mindfulness principles. In addition, servant leadership's aspiration for holistic member wellbeing reflects mindfulness teachings. The servant leadership hierarchical model upends traditional organization constructs, demonstrating a mindfulness view of community whereby the leader serves all rather than all serving the leader. This echoes Buddhist monastic communities in which power is shared yet structure is provided. Research reveals further connections of mindfulness to servant leadership that were unexpected: forgiveness, spirituality, and morality. Also cultural in mindfulness, servant leadership embraces acceptance of, being present with, and openheartedness toward others. This organizational culture scores highly in job satisfaction and employee retention matrices that indicate mindfulness principles as correlative. Current trends in organizational ethos well position servant leadership for 21st century systems. These trends reflect a societal will for inclusivity, collective power, and leaders who share an accepting and authentic self with the wisdom required for discernment and compassion.

Keywords: awareness, presence, acceptance, mindfulness, servant leadership

Table of Contents

Abstract	ii
List of Figures	iv
List of Hyperlinks	v
Introduction.....	Error! Bookmark not defined.
Positionality	2
Notes on Terminology and Context.....	3
An Examination of Mindfulness: Origin, Emergence, and Precepts	10
An Examination of Servant Leadership: Origin, Emergence, and Precepts	14
Profile: Servant Leadership Founder Robert K. Greenleaf.....	17
Servant Leadership as Organizational Mindfulness	19
Discussion	47
Implications for Further Research and for Servant Leadership in the 21 st Century	53
Conclusion	56
References.....	57

List of Figures

1. Figure 1. Conceptual model of relational effect: job involvement, servant leadership, and organizational identity
2. Figure 2. Conceptual model and hypothesis: Identification with servant leadership at top and bottom level of organization on team creativity
3. Figure 3. Research model and hypotheses: Relational effect of servant leadership (SL), job satisfaction (JS), and leader-member exchange (LMX)

List of Hyperlinks

1. Greenleaf Center for Servant Leadership: <https://www.greenleaf.org/>
2. Poetry Foundation: <https://www.poetryfoundation.org/poems/44261/the-death-of-the-hired-man>
3. Forbes: <https://www.forbes.com/sites/robertamatuson/2019/10/30/hidden-talent-the-case-for-hiring-neurodiverse-candidates/#54731808768a>

Every organization has a chart that shows who we are *to* each other, but servant leadership turns the chart upside down by focusing on how we are *for* each other.

—Greenleaf Center for Servant Leadership

Servant Leadership as Organization Mindfulness

The paradigm of organizational leadership, particularly within a corporate for-profit environment, has long been one of exclusivity whereby power and influence are progressively generated up to the pinnacle of one specific organizational leader. In stark contrast, servant leadership's organizational model is an inverted one and unique to its leadership philosophy. In servant leadership organizations, the leader is not the apex of the organization. A leader is the starting point upon which all members are supported. This architecture of the servant leadership hierarchy demonstrates a very mindful sense of community as well as a mindful way of being in the world. And while challenges to the power leadership model have been staked by various other leadership philosophies, servant leadership is distinctive in its integration of mindfulness precepts. It is in servant leadership's profound aspiration for community wellbeing—that both the individual and the organization may be benefitted—that one finds foundational mindfulness teachings. Given the growing cultural demand for inclusivity and acceptance in all areas of our lives, and the burgeoning cultural interest in mindfulness, servant leadership may offer the most promising organizational philosophy for the times.

I begin this study by offering my positionality that helped provide the impetus for this investigation. I then present definitions and context for those mindfulness precepts most expressed in servant leadership philosophy, terms to which I frequently refer. In addition, I include key terms for servant leadership philosophy. I follow this section with a general

discussion of the origins, Western/US emergence, teachings, and practices of mindfulness. This is followed by a similar discussion of servant leadership's historical roots and philosophy. I then provide a brief profile of Robert K. Greenleaf, founder of the servant leadership movement. I continue with an examination of servant leadership's integration of selected mindfulness precepts, including servant-leader characteristics that embody those precepts. I include a review of results reported—self and observational—of servant leadership organizations and employee/member wellbeing, as reported via such vehicles as job satisfaction and employee retention rates. I then offer personal observations on the literature supporting servant leadership philosophy as inherently mindful, along with any revelations that were discovered in the execution of this study. I discuss current trends in organizational culture that were presented within the literature and I consider servant leadership philosophy in current social and business climates and for the immediate future. In conclusion, I encapsulate the salient points of this study that support the thesis of servant leadership as organizational mindfulness.

Positionality

My work experience is this paper's *raison d'être*. I spent a decades-long career in corporate, for-profit companies. Without exception, every company embraced the bottoms-up model of leadership whereby all served one. This leadership model was typically exhibited through command-and-control behaviors. Fear stifled community and the adversarial culture was stressful. While many of the companies endeavored to promote cohesion and bonding through sensitivity training and team-building exercises, the existing culture made the efforts seem insincere. No single company sought to be truly inclusive and valuing of its employees. To the contrary, intense competition was encouraged, working less than 50+ hours a week was detrimental, and managers were often considered opponents. But it was my privilege to have

been led by one manager, singular in my entire career, who exhibited characteristics I would come to understand as servant-leader. This manager had a profound impact on my professional life and on my own management style.

It was not until my Lesley University course, Mindful Leadership and Conscious Social Change (Roberts, 2017), that I would be introduced to the philosophy of servant leadership. I would also learn of its connection to mindfulness. Exposure to this healthier and alternative management philosophy was revelatory. Knowing firsthand the negative effects of the power model of leadership, I felt compelled to champion this more compassionate organizational philosophy of servant leadership. I was keen to understand the specifics of how servant leadership philosophy expresses mindfulness. My interests coalesced with this study. It is with the positionality that servant leadership exemplifies mindfulness that I conducted this investigation. I present this paper as a culmination of my professional experience, my academic work, and my enthusiasm for a more inclusive and compassionate work environment. It is my hope that by offering direct comparisons of servant leadership to mindfulness, I add to the literature endorsing this position and thus help elevate awareness of the inherently uplifting organizational approach of servant leadership.

Notes on Terminology and Context

The terminology of both servant leadership and mindfulness is distinctive and expressive of a philosophical position. The language is not typically found in the common vernacular and, as such, this paper uses terminology that calls for exposition. Providing definitions and context should help establish a more communal understanding. I have attempted in this study to focus on terms and expressions of mindfulness that are embraced by the philosophy of servant leadership, terms that articulate characteristics of servant leaders and of servant leadership organizations,

terms that may be in the cultural lexicon but beg a refined definition with regard to this paper's focus, terms discovered during my research of the literature that revealed a connotation beyond the common, and terms that help establish a fuller understanding of the perspectives expressed within this paper. This is by no means a complete thesaurus of terms and phrases used herein or found in either philosophy; rather, it is to establish those primary for the paper's rationale and the impetus to conduct this study. Readers may have a personal differing understanding of the individual terms and are welcome to bring such interpretation or challenges to the reading of this paper.

Mindfulness

Two primary resources helped to frame mindfulness and its philosophy in the manufacture of this report. The first is Joseph Goldstein's (2013) *Mindfulness: A Practical Guide to Awakening*. Credited as among the first to launch the mindfulness movement in the United States, Goldstein offers a considered analysis of mindfulness for a Western audience. While he tells us that full exploration of the content and meaning of mindfulness is a lengthy pursuit, he offers *being present*, *present moment awareness*, and *living in the moment* as first intimations of the meaning of mindfulness. The second resource to articulate mindfulness is Bhante (Venerable Sir) Henepola Gunaratana's *Mindfulness in Plain English* (2015). Teacher, author, and Buddhist monk Gunaratana refers to mindfulness as a special mode of perception, a unique way of seeing the world as it truly exists. For Gunaratana, mindfulness is pure, wordless bare attention. He writes, "Mindfulness is nonjudgmental observation. It is that ability of the mind to observe without criticism. With this ability, one sees things without condemnation or judgment...one just observes" (pp. 132-133). I selected these works not only for the authors' agency within the mindfulness community, but also as situating well with my personal experience of mindfulness.

This experience is deeply informed by my graduate program at Lesley University, particularly, my coursework in Mindfulness: Practice, Theory and Science (Waring, 2017), and Foundations of Contemplative Practice: The Buddhist Traditions (Hartranft, 2017). In fact, it was within my Mindfulness: Practice, Theory and Science course that I came to a definition that most resonates with me: mindfulness is a non-reactive observation of what is happening at any moment, allowing discernment and gentleness to arise. This is the platform upon which I approached the material.

I would like to point out that mindfulness is rooted in Buddhism, and an appreciation of the precepts may, therefore, be presumed challenging to some. Alternatively, in the United States, mindfulness is often referred to as an action undertaken to reduce stress. While certainly the mindfulness practice of meditation, integral to mindfulness philosophy, has been shown to reduce stress, this colloquial definition of mindfulness is reductive and needs mentioning.

Servant Leadership

The best definition of *servant leadership* may be found in this explanation: “There are many ways to serve, and leading is one of them. Instead of leading by serving, then a servant-leader is serving by leading” (Keith, 2012, Isn’t Servant Leadership a Contradiction section). In his book *Questions and Answers About Servant Leadership*, Dr. Kent M. Keith, then Executive Director of the Greenleaf Center for Servant Leadership, tells us servant leadership is not a specific style or set of rules of leadership. Although servant leadership allows flexibility as circumstances dictate, being of service is always foremost and essential. *Servant-leaders*, according to Robert K. Greenleaf (1970/2008), founder of the Servant Leadership movement, possess 10 characteristics: listening, empathy, healing, awareness, persuasion, conceptualization, foresight, stewardship, commitment to the growth of people, and building community. Much as

with attempting to articulate mindfulness, describing servant leadership is a nuanced endeavor. However, it is the key principle of an abiding wish to be of service that anchors any interpretation of servant leadership and any list of servant-leader traits herewith.

Right Action, Right Thought, Right Livelihood

In Buddhism, the desire to be of service to others is associated with *Right Action*, a step on the Noble Eightfold Path toward true awakening (Goldstein, 2013). Goldstein tells us the Buddha expressed Right Action famously as “avoid what is unskillful, do what is good, purify the mind” (p. 379). Elucidating, the Buddha advised refrainment from taking a life, taking what is not given, intoxication, false speech, and sexual misconduct. Considering Right Action in the performance of service for others, we expand our insight into its deeper meaning. We enrich our insight into Right Action through its many aspects of service, such as community, compassion, and morality. Goldstein explains, “As we try to apply and practice this in our lives, we come to the forward edge of our understanding and commitment” (p. 380). For this study, I adhere to the definition of Right Action as service.

Goldstein (2013) describes *Right Thought*, another step on the Noble Eightfold Path, as compassion, and defines it as “all the intentions and aspirations that lead to wholesome actions, which result in the welfare and happiness of ourselves and others” (p. 361). We need to be free of ego, sense desire, and cruelty. This allows us to truly extend lovingkindness. Loving kindness is a component of Right Thought. This openhearted response to others is central to my interpretation of Right Thought as compassion. As such, it informs my analysis of the literature on servant leadership’s aspirations for its organizational members.

Right Livelihood, Right Action and Right Thought fall within the morality group in Buddhism. Distilled to its basic interpretation, Right Livelihood is work that does no harm. The

Buddha listed specific industries to avoid, including any work involving deceit (Goldstein, 2013). But it is also possible to approach Right Livelihood as an attitude of service in the performance of one's work. Goldstein asks, "Do we work with care, with attentiveness to others, with a genuine desire to be helpful?" (p. 386). In my investigation of the literature, I call on this keener definition of Right Livelihood as work that involves direct service and/or the intention to be of genuine aid to others in the commission of that work.

Lovingkindness

According to Goldstein (2013), prominent Buddhist Master Dipa Ma once responded, when asked if mindfulness rather than lovingkindness should be practiced: "From my experience there is no difference. When you are fully loving, aren't you also mindful? When you are fully mindful, is this not also the essence of love?" (p. 359). Releasing the ego, we are awakened to the true nature of phenomena and the desire to earnestly bring about joy for others. We allow the reality that our lives are inextricably connected each to the other to arise. According to Gunaratana (2015), "The ego sense itself is essentially a feeling of separation—a perception of distance between that which we call *me* and that which we call *other*" (p. 163). As I define openheartedness and lovingkindness, it is with an associative non-attachment to the ego. Openheartedness and lovingkindness are both postures of group care and self-care and reflect the interdependence of others to self. Both call for a capacious spirit and presence that does not cling to the ego.

Acceptance

In his essay that established the concept and terminology of servant leadership, Robert K. Greenleaf (1970/2008) paired *acceptance* with empathy. He defines acceptance as "receiving what is offered without acquiescence" (Acceptance and Empathy section). While Merriam-

Webster (2014) lists a primary definition of acceptance as an act of approval, it does not hit the mark entirely for this study. Goldstein (2013) calls lovingkindness the second act of Right Thought. Acceptance, he continues, is being free of ill will. The terms acceptance and lovingkindness are certainly interchangeable in some circumstances. It is this interpretation of acceptance as being free of ill will that situates it well herewith. Gunaratana (2015) advises us that mindfulness is accepting what is there. It has been my experience that acceptance has been associated in the common vernacular with resignation, another word that is nuanced. Resigning oneself to “accept what is” need not carry a heaviness or negative connotation. His Holiness, the Dalai Lama (2012) calls acceptance of reality an aspect of patience. This definition expands the mindset with which I have conducted this study. Herein, acceptance is defined as a generosity of intention toward and receiving from another without judgment. In addition, it is an abiding of reality or circumstances, as applied to certain aspects of this report.

Sangha

Goldstein (2013) describes the *sangha* as simply any community of Buddhist practitioners. He tells us the Buddha founded the sangha as a community for mutual encouragement and support. The Buddha recognized the importance of a sangha in consoling feelings of aloneness that arise in our lives. Awareness that others have faced a same sense of isolation or suffering is solace. The sangha reminds its members they are not alone or left with no hope as they face personal struggles along the path to enlightenment and the cessation of suffering (Gunaratana, 2015). The sangha also provides supportive precepts toward that pursuit to ease suffering. The Buddhist monastic sangha is essential for the very existence of Buddhism in any given society. The monastic sangha holds the knowledge of the Buddha’s teachings and it preserves those teachings. The constitution as set forth in the ancient canon of monastic Buddhist

life creates an organizational hierarchy for the sangha according to ordination seniority, but it does not allow for a formal leader. Authority is by consensus of groups of senior monks, thus promoting flexibility according to needs while providing structure. This leadership structure has worked to preserve the sangha for thousands of years and in diverse cultures (Gethen, 1998).

Merriam-Webster's (2014) Collegiate Dictionary notes that an organizational *community* is an assortment of people interacting in a common place. In Western parlance, sangha is sometimes referred to as one's like-minded group. For purposes of this study, I associate organizations with community. Works of service require recipients; existential to servant leadership is a community to which service is provided. For purposes of this study, community may be scaled to include all of society or may simply be the relationship between servant-leader and follower.

Spirituality

Merriam-Webster (2014) provides one definition of the word *spiritual* as concern with religious values, of which integrity may be assumed (2014). Integrity promotes an atmosphere of *spirituality* in servant leadership (Keith, 2012), eliciting a deeper cooperation and care among organizational members (Keith, 2015). Buddhist texts correlate wisdom and compassion with spiritual qualities. The Buddhist praxis of *bhavana*—cultivating—in meditation practice develops the spirit and the mind (Gethen, 1998). It is with an understanding of spirituality as secular and experiential that I approach the literature.

Morality may be defined as behavior that relates to the principles of right and wrong and as synonymous with ethics (Merriam-Webster, 2014). For purposes of this paper, I also call on the *moral tenor of the mind*, that ability to observe without ego, self-interest, or such postures that diminish the capacity to observe reality clearly (Olendzki, 2010). The Buddha referred to the

force of the mind to watch over moral behavior as *hiri*. Olendzki tells us that *hiri* “connotes conscience, moral intuition, and self-respect” (p. 53). It is that intrinsic understanding within human beings of what is ethical or right or noble. Herewith, it is the definition of *moral* as ethical that is more keenly applied.

I highlight and co-list these two terms as having gradations of meaning that differ from common usage and associations. Both spirituality and morality are rooted in the philosophies of mindfulness and servant leadership. Their definitions, as applied to this investigation, require a fuller understanding and context beyond the more commonly associative religious assumptions.

It is my hope that the above conversation on terms used in the commission of this project will help establish a mutual understanding of the language and of the intent that propels the study forward.

An Examination of Mindfulness: Origin, Emergence, and Precepts

It could be said the United States first became culturally aware of Eastern Buddhist principles and mindfulness as early as 1961 when Vietnamese Buddhist Monk Thich Nhat Hanh began teaching Comparative Religion at Princeton University. In 1966, as the Vietnam War escalated, Thich Nhat Hanh returned to Vietnam to support his fellow monks in their nonviolent peace efforts. One year later, Dr. Martin Luther King, Jr. nominated him for the Nobel Peace Prize. Buddhism, Thich Nhat Hanh, and mindfulness precepts such as lovingkindness and Right Action entered the national lexicon.

Goldstein (2013) tells us mindfulness more generally entered the zeitgeist in the United States in the 1970s. One of the early influencers was Jon Kabat-Zinn. Kabat-Zinn, founder of and famously known for the Mindfulness Based Stress Reduction program, was instrumental in establishing a cultural awareness of mindfulness here in the United States. While earning his

Ph.D. at MIT, and actively campaigning against the Vietnam war himself, Kabat-Zinn attended a Zen missionary presentation, leading him to study meditation and mindfulness. A student of Thich Nhat Hanh, among various other Buddhist teachers, Kabat-Zinn would go on to study at the Insight Meditation Society (IMS) in Barre, Massachusetts. At IMS, Kabat-Zinn worked with co-founders Sharon Salzberg and Joseph Goldstein to expand awareness of the Buddha's teachings in the United States. Goldstein (2013) tells us it all started with meditation retreats to introduce the concept and practice of mindfulness and meditation. The concept continued a trajectory toward widespread credibility and interest (p. xiii). Culturally, the term mindfulness would evolve to and then devolve from a general association with stress reduction. While certainly the practice of meditation, foundational in mindfulness, leads to mind-body ease, this is but one aspect of the practice of mindfulness. One need only examine academe and literature to appreciate that the understanding of mindfulness, here in the United States, has developed in scope and now conveys a broader and more sophisticated interpretation.

Mindfulness, both the concept and the practice, began with the teachings of the Buddha (the *Enlightened One*) over 2,500 years ago. In discourses to his monks, the Buddha calls mindfulness the third quality of mind, a term undefinable specifically and taking any number of different roles actionably. But the fundamental goal of mindfulness is wisdom (Goldstein, 2013). Mindfulness is a state of profound awareness of what one is experiencing, whether it be physical, emotional, or psychological. In mindfulness, the mind is settled and observes all without reaction or exertion, seeing whatever sensations arise and fall more clearly. An analogy author Gunaratana (2015) makes is that observing the moon is mindfulness; assessing the moon is not. Olendzki (2010) notes, "When true mindfulness arises, one feels as if one is stepping back and observing what is happening in experience, rather than being embedded in it" (p. 172). In

mindfulness, one does not judge or interpret or react; thought is rooted in the moment and allows whatever is. There is freedom in mindfulness, and this freedom leads to wisdom, this wisdom to unlimiting the mind (Olendzki, 2010).

Through an understanding of the ability of mindfulness to protect the mind by alerting it to physical sensations, emotional conditions, and thoughts that are harmful, one can discern the choices to guard against them. Goldstein (2013) instructs that “it is never about blind belief, but about the wisdom of our own inquiry” (p. 384). Gunaratana (2015) tells us that mindfulness is translated from the Pali word *sati*, which is defined as an activity. But the author goes on to describe mindfulness more as an experience. Goldstein (2013) cites this ability to choose healthier thoughts in the discourse on “The Two Kinds of Thoughts.” The Buddha states:

When I considered: ‘This (thought) leads to my own affliction’, it subsided in me; when I considered, ‘This leads to others’ afflictions’, it subsided in me; when I considered, ‘This leads to the affliction of both’, it subsided in me’, when I considered: ‘This obstructs wisdom, causes difficulties, and leads away from Nibbana,’ it subsided in me. (p. 17)

Examining one’s thoughts leads to self-insight, another pillar of mindfulness and its practice. In this way of deep focus, one may practice Right Thought.

Right Thought, a step on Buddhism’s Noble Eightfold Path, is achieved through the practice of mindfulness. In the Rinzai school of Zen Buddhism, one tricks the mind into the state of pure (mental) awareness or experience through the rigorous exercise of attempting to solve an unsolvable riddle (Gunaratana, 2015). Zen Buddhism is particularly rigorous in its pursuit of disciplining the mind toward profound awareness. Tantric Buddhism, a tradition that teaches enlightenment through more transcendent or spiritual practice, seeks to achieve pure awareness

through first being aware of conscious thought and how it is affected and influenced by the ego or self-concept. Self-concept is a false narrative that constructs the ego, and pure awareness can never be obtained while thought is attached to this self. Tantric training, Gunaratana continues, encourages the student to focus on a (typically religious) personage/image: “She takes off her own identify and puts on another...she is able to watch the way in which the ego is constructed and put in place” (p.25). The letting go of one’s own self-concept allows a deeper awareness and an unbiased view of reality.

Mindfulness may also be expressed through what is called Right Livelihood. The Buddha recognized the central place work takes in, and that it consumes a large portion of, our daily lives. By extension, mindfulness calls upon the choice to do no harm in our livelihood, to be mindful and considered in our work. Right Livelihood, one of three steps or expressions categorized into the moral group, identifies specific livelihoods to avoid, such as participating in the manufacture or trade of weapons or instruments for killing. But there is a positive and aspirational step one can make for Right Livelihood, and that is to commit to being of service in performing one’s work. The Buddha cautioned, however, against letting the reward of good feelings achieved through service to others encourage the ego. Service must be approached with a humble heart–mind. It should be rooted in the aspiration for our lives to be about more than just ourselves. Right Action, also of the Noble Eightfold Path, may be achieved through one’s livelihood. The conduct of one’s personal and professional life may express both Right Action and Right Livelihood and thus the right steps of mindfulness toward morality. Without Right Action and Right Livelihood, our wisdom and mindfulness does not allow for our awakening. It is by ethically practicing these steps in the world we embody them (Goldstein, 2013).

An Examination of Servant Leadership: Origin, Emergence, and Precepts

Servant leadership launched as a philosophy in 1970 with the publication of Robert K. Greenleaf's, *The Servant as Leader*, in which the phrase was first coined (Greenleaf Center for Servant Leadership, n.d.). The philosophy would become a movement. First established in 1964 as the Center for Applied Ethics, the Robert K. Greenleaf Center for Servant Leadership grew with that movement. For over two decades the global nonprofit has worked to increase awareness, understanding, and the practice of servant leadership through its various programs for individuals and organizations. The Center continues the pursuit of a better and more just society by instilling in its organizations people-centricity and leadership that works to enrich the lives of those people.

The Center's website states that servant leadership calls for "radical personal and corporate accountability, deep inner work, and an effort to develop capacities like systems thinking, persuasion, intuition, foresight, and listening with presence" (Greenleaf Center for Servant Leadership, n.d., Greenleaf's Best Test section). This reference to listening with presence is an unabashed nod to mindfulness philosophy and speaks to the spiritual and moral. Of servant leadership's relevance for present day organizations, Stephen R. Covey (2002) notes, "The deepest part of human nature is that which urges people—each one of us—to rise above our present circumstances and to transcend our common nature" (Forward section). Appealing to this nature allows access to an intrinsic human motivation. Covey points out, "Perhaps this is why I have found Robert Greenleaf's teachings on servant leadership so enormously inspiring, so uplifting, so ennobling" (Forward section). Thus, we see the Greenleaf Center for Servant Leadership as vital in communicating this globally relevant message.

A well-known gospel accounting of a servant-leader relationship is Jesus washing the feet of his disciples and encouraging them to do so for others (Sendjaya & Sarros, 2002). But Christianity did not codify this as a leadership philosophy. Monarchs and politicians may claim a mandate to serve their public, and governmental organizations may serve at the needs of the people, but decisions are too often by fiat and none should be assumed servant-leader. Servant leadership has been compared with charismatic leadership, a concept also found in religious literature. Charismatic leadership similarly adheres to a philosophy of profound service to all and above self, but it diverges from servant leadership in how leadership is bestowed. Charismatic leaders are conferred by divine right, whereas servant-leaders are chosen by those whom they serve, not by God. Greenleaf (1970/2008) developed the principles of servant leadership based on a simple but profound idea that leaders whom we trust and want to follow achieve moral authority by being servants to followers and organizations, not by wielding titles or using coercive power. In this way, we are reminded of monastic Buddhist leadership's communal authority. Servant leadership does not claim or align with any one religion or institution. It is a philosophy for all people and organizations. "A better society, one that is more just and more loving, one that provides greater creative opportunity for its people," (Greenleaf Center for Servant Leadership, n.d., What Is Servant Leadership? section) is at the heart of servant leadership philosophy.

The Center's call to action has distinct aspirational goals for its member organizations and servant-leaders. Traditionally, organizations focus on measuring profit, sales growth, customer base growth, inventory turnover, etc. Servant leadership organizations measure these categories for success as well. But servant leadership organizations measure their success, in addition, in terms of positive societal impact. To this end, Greenleaf devised a proprietary means

test, the Greenleaf Best Test® (Greenleaf Center for Servant Leadership, n.d.) for measuring the efficacy of its organizations and servant-leaders. As much road map as measurement tool, the Greenleaf's Best Test® reveals inner and outer progress. It is not a rubric for quantifying or identifying knowledge. Nor is it designed to catalog objectives. Greenleaf devised the measurement tool for organizations to assess their imprint on society, to evaluate the personal development of their employees, and to evaluate the efficacy of their servant-leaders.

Servant-leaders are the vehicle by which the leadership philosophy is implemented in member organizations. Greenleaf (1970/2008) identified 10 specific characteristics that define servant leaders. They include listening, empathy, healing, awareness, persuasion, conceptualization, foresight, stewardship, commitment to the growth of people, and building community. But the most fundamental quality that defines a leader is an intrinsic desire to serve (Keith, 2015). A natural spirit of wishing well for others and wanting to be instrumental in their wellbeing or growth is a unique and characterizing quality of servant-leaders. Although one can be instructed on how to be of service, circumstances can render this training impotent. It may be ultimately revealed as inauthentic, should time or circumstances bear down on the learned behavior. A true servant-leader has an innate, unshakable desire to be of service. It is not something fragile or subject to events or conditions. It cannot be taken away (Spears & Lawrence, 2004).

Greenleaf (2002) wrote that "Humility is the foundational attribute of sacrifice" (Moral Authority and Servant Leadership section). Servant-leaders start from a posture of humility. "Humble behaviors are an outcome of a servant-leader's heart. Servant leadership can be defined as a mindset or paradigm; humble behaviors are how a leader carries out this paradigm," authors Hayes and Comer point out (2010, p. 147). Servant leadership calls for systemic inclusion and

compassion, and for its servant-leaders to relinquish ego and self-interest, in building a societal community of moral character and toward the greater good.

Profile: Servant Leadership Founder Robert K. Greenleaf

Robert K. Greenleaf attributed his father to be the original model for a servant-leader, but he credited a teacher for activating his awareness that corporations and large organizations did little to serve the needs of society or its members (Greenleaf Center for Servant Leadership, n.d.). His fervent wish to change that status quo established his commitment to influence change from within organizations. His 38-year career with communications giant AT&T, one of the largest organizations in the world at that time, served his purpose well. It also proved fertile ground for Greenleaf's philosophy of servant leadership to develop. As a member of AT&T's first management training program, Greenleaf spent several years troubleshooting AT&T's conglomeration of companies. In that capacity, he observed that the more robust affiliates were those with especially supportive leaders, leaders who seemed more coach than boss (Greenleaf Center for Servant Leadership, n.d.). Greenleaf observed that those leaders who were actively serving their individual members as well as the group had an approach that was uncommon at that time. Greenleaf took notice: "The organization exists for the person as much as the person exists for the organization" (Greenleaf Center for Servant Leadership, n.d., Robert K. Greenleaf Biography section). Greenleaf's contribution to AT&T was considerable and his biography reveals a natural predilection toward acceptance and inclusivity:

Director of Management Development, originator of the world's first corporate assessment center, promotion of the first females and Blacks to non-menial positions, a program to expose up-and-coming leaders to the humanities, even bringing in famous theologians and psychologists to speak about the wider

implications of corporate decisions. (Greenleaf Center for Servant Leadership, n.d., Robert K. Greenleaf Biography section).

We see, in this short biographical account of his time at AT&T, elements of Greenleaf's management style that would serve as the framework upon which servant leadership philosophy would be constructed.

Greenleaf (2002) wrote that it was Hermann Hesse's (1932/2018) *The Journey to the East* that provided the spark for his servant leadership movement (The Servant as Leader section). In *The Journey to the East*, a small group of members of a timeless religious sect—the League—embark on a pilgrimage across time and space, encountering geography and persons real and imagined, to find Truth. The group is aided by their humble servant, Leo, whom Greenleaf described as having profound presence. Leo becomes indispensable to the group, which is thrown into despair and crisis when he disappears. Years later and after much effort, Hesse's narrator finds Leo, who is revealed as the President of the League. There have been numerous interpretations of Hesse's book, but it is Greenleaf's construal that reveals the origins of his servant leadership philosophy. For Greenleaf (1970/2008), the remarkable in the narrative was the revelation of the servant Leo as having secretly been President of the League all along. Leo never disclosed his true position. Rather, he joyfully, humbly provided menial and spiritual service to the pilgrims. The principles by which Leo led—humility and service—inspired a paradigm shift in organizational philosophy for Greenleaf. Leo's example of selflessness and non-attachment to the ego modeled a revelatory way to lead. One could be a servant-leader.

Authors Sipe and Frick (2015) offer an anecdote of how Greenleaf turned down promotions he feared would usurp moral authority. Formal authority held no sway for Greenleaf if it compromised his leadership principles. Greenleaf, the authors tell us, never assumed moral

authority came automatically with a title or position, or even with a claim of moral authority. Instead, moral authority must be earned by those led. Servant-leaders are conferred moral authority through their actions. Here we see the anchoring sentiment for Greenleaf: who a person is *for* another is more profound than who the person is *to* another. We also find the qualities of profound humility and non-attachment to ego in Greenleaf's posture. These qualities of humility and caring for others above oneself are also found in the practice of mindfulness and are inherent in its philosophy.

Servant Leadership as Organizational Mindfulness

In researching the literature on servant leadership, I sought out articles and books that describe how servant leadership integrates mindfulness either philosophically or actionably. I also selected literature on the demeanor and characteristics of servant-leaders, vital to the performance of servant leadership principles and, a priori, mindfulness. This investigation was also informed by my Lesley University graduate program courses Mindfulness: Practice, Theory and Science (Waring, 2017), Foundations of Contemplative Practice: The Buddhist Traditions (Hartranft, 2017), and Mindful Leadership and Conscious Social Change (Roberts, 2017). It was in my Mindful Leadership course that I was first introduced to the concept of servant leadership and its consideration as a mindful leadership model, providing the impetus for this paper. While the course offered me an introduction to servant leadership, time constraints did not allow a deeper examination of its philosophy. This study more profoundly explores the discernible reasons for servant leadership's consideration as mindful leadership.

Topics selected in this discussion are those that reveal a rich connection between mindfulness teachings and servant leadership philosophy. Conversation within these topics shows language and practice similarities and illuminates philosophical and aspirational parallels

between the two philosophies. These discussion topics show how a mindful way of being in the world informs servant leadership, for instance, the concept of community. By detailing the various methods by which servant leadership embodies mindfulness precepts, I provide a fuller rationale for servant leadership's inclusion as mindfulness in a systems environment. In addition, in discoursing servant leadership's aspiration for member growth and positive development, I include reports as to efficacy. I review existing literature on organizational reports as well as employee self-reports on job satisfaction, employee retention, and organizational performance. All are pertinent to examining servant leadership's desire for holistic member wellbeing and it is through this lens I examine these reports. Wellbeing is aspirational in mindfulness as well, serving as just one example of several connection points.

Materials that provided the rationale for my discussion came equally from peer-reviewed journal articles published generally after 2000, and from books, essays, and other publications suggested on the Robert K Greenleaf Center for Servant Leadership (n.d.) site or from digital resources gleaned directly from the site itself. In addition, I selected various recommended readings in Kent M. Keith's *The Case for Servant Leadership* (2015). Literature informing my understanding of mindfulness was garnered primarily from *Mindfulness: A Practical Guide to Awakening* (Goldstein, 2013), and *Mindfulness in Plain English* (Gunaratana, 2015), with additional texts on mindfulness or Buddhism sourced where supportive and applicable. One additional resource of note is the *Cognitively-based Compassion Training Manual—Prepared for Teacher Certification* (Negi, 2018). Digital material was primarily selected from the Greenleaf Center for Servant Leadership (n.d.) online presence.

This discussion of the literature begins with a comparison of servant leadership's philosophy and practices to those of selected mindfulness precepts. I identify language, methods,

and objectives that connect the two. Provided herewith is an assessment of servant-leaders themselves as characteristic of and embodying mindfulness. I include in these comparative topics a similarity of servant leadership's abiding interest in positively impacting society to that same aspiration of mindfulness. I then move on to a summary consideration of these taxonomies as evidence of servant leadership's integration of mindfulness philosophy and discuss any revelations from the work. I provide observations on the implications for servant leadership in today's cultural and business climate, and in the foreseeable future. This study concludes with a review of those significant points that support the hypothesis of servant leadership as organizational mindfulness.

Ultimately, the aim of this study is to identify and illuminate key precepts of servant leadership philosophy that connect it to mindfulness. When asked why servant leadership is not more widespread, given its unique position to address 21st century organizational needs, Dr. Kent M. Keith (2012) noted, "People want to be effective and if they don't know enough about how they can be effective as servant-leaders, they may not be interested" ("If servant leadership is so effective" section). It is my hope this considered comparison of servant leadership to mindfulness not only supports servant leadership as mindful leadership philosophically, it demonstrates the *how* actionably.

Community

In the realm of mindfulness, community is often referred to as a sangha and is typically a collective of Buddhist practitioners (Goldstein, 2013). The Buddha's intent for the sangha was to provide the comfort of companionship and evidence that one is not alone. We find nurturance in recognizing there are others from whom we can draw reassurance and encouragement to ease suffering. A sangha, or community, provides support and it offers hope as we face personal

struggles along our path in life (Gunaratana, 2015). For servant leadership, community allows the very practice of service. In doing so, it offers the comfort and support of which the Buddha counseled. For servant leadership organizations, developing social capital—trust among and connections between employees, suppliers, and customers—is just as vital as intellectual capital and physical assets or capital. Servant-leaders are encouraged to be vigilant for opportunities to build social capital within their organizations, whereby a stronger organizational community may be forged (DeGraaf et al., 2013). In this way, servant leadership embraces the mindfulness intent of the community, be that community society itself or a specific organization. In servant leadership theory, society is the greater sangha. Its value lies in allowing the Buddhist and mindful mission of easing our and each other's suffering through connection.

Gethen (1998) tells us the sangha is one of the three jewels of Buddhism in which to find refuge. Here we see servant leadership as providing refuge in its good works. The Greenleaf Center for Servant Leadership (n.d.) is quite clear that their leadership model promotes the lifting up of those less fortunate toward a better society, one that is more just and more loving, one that provides greater creative opportunity for its people. “Both an ancient philosophy and modern practice, we envision that servant leadership as a movement will continue to enrich the lives of individuals and establish more people-centered institutions as well as strengthen its vital relationships” (Our journey: Our Mission and Vision section). In this, we are reminded of the Buddhist monastic sangha providing guidance in addition to moral and spiritual support.

One aspect of the sangha not commonly associated with mindfulness is *sati*, defined as remembering. This wholesome recollection of the virtues of the sangha and of our own capacity for generous and moral conduct arouses confidence and faith (Goldstein, 2013). One finds inspiration in this way. Servant leadership organizations purposefully work to provide

encouragement and inspiration for the community (Spears & Lawrence, 2004). The Sangha keeps us on our path (Gunaratana, 2015). Servant leadership does so as well, by encouraging a more inclusive model for organizations:

One of teamwork and community, one that seeks to involve others in decision making, one strongly based in ethical and caring behavior, and one that is attempting to enhance the personal growth of workers while improving the caring and quality of our many institutions (Spears & Lawrence, 2004, Who is the Servant Leader section).

Spears and Lawrence (2004) note that organizations of differing profit models can successfully move from the command and control, top-down management style that has dominated the organizational landscape to the communal, bottoms-up model of servant leadership. This servant leadership philosophy of fundamental interconnection within its member organizations exemplifies a Buddhist mindful understanding of community.

The servant leadership organizational hierarchy particularly expresses a mindfulness sentiment of each member's value to the sangha. Rather than a pyramid-shaped hierarchal structure in which all serve the one at the top, a servant leadership organization's hierarchy is inverted and expands out and upward. In this way, all members of the organization are contributory. Spears and Lawrence (2004) tell us "Servant leadership advocates a group-oriented approach to analysis and decision making as a means of strengthening institutions and improving society. It also emphasizes the power of persuasion and seeking consensus over the old top-down form of leadership" (The Understanding and Practice of Servant Leadership section). This upside-down-pyramid organizational structure more demonstrably depicts that the responsibility for the group rests upon the leader. It also demonstrates that those resting upon the leader are

equally important to the leader themselves. A servant-leader is not pinnacle to the organization; rather, the leader holds a supportive position. One serves all and all share support for the group. Constitutionally, the ancient canon did not allow for a formal leader in Buddhist monastic community. While there was seniority by ordination date, authority was by group consensus of senior monks (Gethen, 1998). This monastic mindful leadership example speaks more closely to that of servant leadership whereby structure is provided, yet all are considered. The servant leadership hierarchy is one of humility and is non-egoistic. It shuns the traditional autocratic model for one expressive of mindfulness precepts. We learn that in doing so, servant leadership organizations encourage members to feel safe to speak up and offer ideas that may better provide for the group. This empowering and accepting culture unlocks purpose and imagination that allows for higher performance and engagement (Brandon, 2019). By not hailing one pinnacle leader, servant leadership communities are best served by a humble and encouraging framework.

Goldstein (2013) tells us that great humility is called upon for the practice of compassion and the aspiration to be of benefit to all others. Once again we see this mindfulness precept of embracing humility and eschewing the ego represented in the very structure of the servant leadership organization. Encouraging others to collaborate frees the leader—and the group—to make more considered decisions. Consensus allows a community to act more ethically. When there is freedom to act on initiative, that society is benefitted (Greenleaf, 2002). Rather than through power, freedom led Robert Greenleaf to the experience of humility, forgiveness, and relational justice (Spears & Lawrence, 2004). This social consciousness radiates throughout servant leadership communities, much as it does in those communities practicing mindfulness (Roberts, 2017). On the list of qualities that establish servant leadership as a construct, Linden et al. (2008) place creating value for the community through a deep-felt concern for the wellbeing

of members and the community itself as notable. Organizations with leaders who serve show an appreciation of people, work toward the development of those people and hence build community (Setyaningrum, 2017).

Right Thought, Right Action and Right Livelihood

Right Thought has been referred to alternately as Right Understanding and Right Intention (Goldstein, 2013). Exhibiting Right Understanding, Greenleaf (1970/2008) was keenly aware of the responsibility for the better supposition leaders face in decision making. This expresses an appreciation of Right Thought and the value of knowing one's mind. This awareness is paramount in mindfulness practice. In mindfulness, one may achieve Right Thought through self-insight and self-insight through Right Thought. "Since the test of results of one's actions is usually long delayed, the faith that sustains the choice of the nobler hypothesis is psychological self-insight," according to Greenleaf (1970/2008, Who Is the Servant Leader section). This self-insight springs forth from deep awareness. Deep awareness may be an awareness of one's own mind or of one's experience that leads to the profound awareness necessary for the nobler hypothesis. Goldstein (2013) writes, "We can notice those thoughts inclining toward renunciation, goodwill and compassion, reflect on their value, and strengthen them in our lives" (p. 346). Ergo, thought moves into the embodiment of thought. Through a conscious focus on non-ego and compassion, service to others moves from the realm of self-motivation and into profound service.

Emory University's Center for Cognitive Science and Compassion Based Ethics lists one foundational and six ordered modules for their proprietary meditation protocol, Cognitively Based Compassion Training (CBCT). The sequential modules culminate with the sixth module, *empathetic concern and engaged compassion*:

Those who have developed, to some degree, an experiential understanding of the changing nature of suffering, as well as the self-confidence that they can overcome suffering and its causes will be able to transform empathy into the source of compassion. (Negi, 2018, p. 25)

CBCT's module two, *insight into the nature of mental experience*, prepares the practitioner for this actionable compassion by mindfulness of thought and intention. Servant-leaders manage the dynamism of group needs through relationship building and compassionate intention. An attitude of relationship building is one of nine dimensions of a servant-leader (Linden et al., 2008). True servant-leaders genuinely strive to appreciate, understand, and support their members. CBCT tells us that allowing our inherent compassion to arise through practice compels us to become personally involved in alleviating suffering and facilitating wellbeing (Negi, 2018). Right Thought training allows Right Action to arise. Right Action may be extended through interpersonal responses such as forgiveness.

The act of forgiveness is an example of Right Action. Authors Fehr and Gelfand (2012) argue for its possibility and place organizationally and term their proposed construct a *forgiveness climate*. This extends beyond a localized benevolence and empathy, i.e. employee-to-employee or manager-to-direct-employee. The authors cite Griffin Hospital as an example of an organizational forgiveness climate: "By acting as a servant-leader and helping employees through a difficult downsizing, Griffin's CEO institutionalized compassion as a central cultural value" (p. 676). Concrete acts of compassion may be taken by organizations during difficult times, such as offering programs to assist employees with outplacement or counseling. Servant-leaders may embody institutional empathy and compassion by partnering with their employees toward healing. Greenleaf (1970/2008) described empathy as projecting one's consciousness

onto someone else: “The servant as leader always empathizes” with a keen discernment of mind and awareness (Acceptance and Empathy section). The prosocial and empathetic responses of valuing and forgiveness allow employees negatively affected by such distressing actions as disciplinary action or corporate downsizing to shift perspective and behavior. This shift may ease rumination and self-harm. This awareness leads to a more considered view of reality, leading then to enhanced wellbeing. In describing the key practices of servant-leaders, Keith (2012) promotes high organizational involvement throughout by recognizing all members as contributing and valued. Here we see Right Livelihood in Right Action.

Right Livelihood, included in the morality group in Buddhism and part of the practice of mindfulness, calls for work that does no harm. There are five types of work the Buddha cautioned to avoid: work that trades in weapons and instruments for killing; work that involves trafficking human beings; work that involves the slaughter of animals; work that involves making, selling, or distributing drugs or intoxicants; or work that trades in the production of any type of poison. This advisement toward Right Livelihood includes avoiding any work that involves deceit (Goldstein, 2013). One may imagine advertising agencies or marketing-driven companies to skirt the edge of disclosure and as deceitful, therefore. Yet by focusing on being of genuine service to their customers, these types of organizations may provide Right Livelihood: “Maximizing shareholder value and/or profit maximization make for a bad combination in marketing-driven organizations that strive to be socially responsible” (Bassell & Friedman, 2016, p. 97). For example, authors Bassell and Friedman report that while 75% of senior executives in marketing-driven organizations surveyed in the past decade list innovation in their top three priorities, more than two-thirds report the needle did not move much, if at all, toward more innovation despite the intense focus. The authors purport that social responsibility and servant

leadership, among other critical concepts, stimulate creativity and innovation by instilling these values as not only cultural but also foundational to marketing decisions.

Right Livelihood, in the practice of mindfulness, may also be expressed as the aspiration and attitude of service in our work. Goldstein (2013) adds, “Right Livelihood is not only about what we do, but also how we do it” (p. 388). This hearkens to the proclamation of servant leadership organizations as focusing on how they are to each other rather than what they are to each other. Most importantly, service to others in the fulfillment of one’s work is the very essence of the servant leadership movement’s mission. Greenleaf (1970/2008) stressed that “it begins with the natural feeling that one wants to serve, to serve first” (Who Is the Servant Leader section). This wish to be of service can deepen our lives and the lives of those whom we serve. Mindfulness refers to being of service to others as *bodhicitta*. It is “the awakened heart-mind; the aspiration to awaken in order to benefit all beings” (Goldstein, 2013, p.417). In his seminal essay, *The Servant as Leader*, Greenleaf (1970/2008) describes a servant-leader as having no other agenda than to serve: “The best test, and difficult to administer, is: do those served grow as persons; do they, while being served, become healthier, wiser, freer, more autonomous, more likely themselves to become servants?” (Who Is the Servant Leader section). It is in servant leadership’s aspiration and effort toward healthier, wiser, freer members we find Right Thought, Right Action and Right Livelihood.

Openheartedness and Lovingkindness

Larry Spears, then President and CEO for the Greenleaf Center for Servant Leadership, noted in an interview that accepting others without judgment is particularly effective in developing servant leadership (Dittmar, 2006). Acceptance is a key concept of mindfulness. Gunaratana (2015) writes, “Thus, as genuine mindfulness is built up, the walls of the ego itself

are broken down, craving diminishes, defensiveness and rigidity lessens, you become more open, accepting, and flexible. You learn to share your loving friendliness” (p. 164). Servant leadership urges conduct that is kind and openhearted. This desire for a pathway to wiser and healthier actions when facing conflict shares a vocabulary with mindfulness. One such quality to ease suffering is ardency. Ardency is one of the qualities of the mind toward enlightenment and is foundational in mindfulness (Goldstein, 2013). Ardency suggests benevolence, acceptance, and a devotion born of deeply valuing the other. Servant leadership demonstrates ardency by the importance it places on stewardship (Keith, 2012) and in seeking to uplift those whom one serves.

Greenleaf was definitive that a *natural* desire to serve was fundamental for the servant-leader (Keith, 2015). There are 10 characteristics of servant-leaders: listening, empathy, healing, awareness, persuasion, conceptualization, foresight, stewardship, commitment to the growth of people, and building community. Of these servant-leader characteristics, several are directly associative with mindfulness terminology, (listening, empathy, awareness) or are derivative (building community, healing, stewardship). These characteristics are reminiscent of Hesse’s (1932/2018) character, Leo, who had a philosophical influence on Greenleaf’s servant-leader concept.

Greenleaf’s belief that great leaders intrinsically want to be of service to those they lead would appear a profound manifestation of Hesse’s (1932/2018) work. Servants may be called upon to lead but a true servant-leader, without provocation, is compelled to lead. This compulsion is out of an inherent desire for the group and its members to develop positively. The servant-leader is conferred leadership. Considering all groups and institutions, in fact, Greenleaf (1970/2008) made note that none exist without being conferred by others. Greenleaf tells us that

servant leadership is not superficial or simply a philosophy designed to make leaders feel better about themselves. Rather, “it is call to action, exacting radical personal and corporate accountability, deep inner work, and an effort to develop capacities like systems thinking, persuasion, intuition, foresight, and listening with presence,” according to the Greenleaf Center for Servant Leadership (n.d., Greenleaf’s Best Test: Background section). McClellan (2013) poses this question: “Can those who are not “natural” servants (individuals who are motivated to serve first) become servant-leaders (natural servants who choose to lead by empowering others) by first becoming natural servants, and if they can, how might this be achieved?” (p. 87). An emphasis on the word *natural* is significant. The word is integral to servant leadership’s definition of who may be a servant-leader. While the Greenleaf Center for Servant Leadership may provide a list of the 10 fundamental characteristics that define a servant-leader, Greenleaf makes a considerable point of the inherent or natural desire one must first have to serve. Yet he also allowed that one can develop that deeper desire to serve from having experienced for oneself a servant-leader relationship. A natural predisposition to be of service is something that cannot be taught, however (Dittmar, 2006).

DeGraaf et al. (2013) distill servant-leader behaviors down to six that provide a summary view, as reported by those whom they serve. Three are philosophically aligned with mindfulness: humility, authenticity, and interpersonal acceptance. These may be expressed in the parlance of mindfulness as non-ego, self-insight, and openheartedness. Authenticity may be the most vital characteristic, echoing Greenleaf’s assertion that one must be inherently desirous of being of service. It all starts with the desire to serve. Servant leadership requires personal sacrifice for the greater good and on a continual basis. If the natural desire to serve others is not there, the vigor to continue to serve may wane. If the motivation to be of service is egoistic or for personal gain,

the effort and the leader are both subject to failure (Davis, 2017). For this reason, the personal wish to serve must naturally reside within, or it is subject to dissolution.

Albright (2016) advises us to seek out the leadership style that best suits our inherent personality before truly embarking on any leadership style. Considering servant leadership, those whose strengths lie in robust mentoring, teaching, or collaborating will find servant leadership the conduit for a fulfilling leadership career. Essentially, leaders who develop and grow those around them are servant-leaders. Albright lists four key pathways toward that end: 1) responsibility and collaboration that engage members in the processes and in the overall big picture, 2) team-building and relationships that make for a more rewarding career than title or hierarchical position, 3) genuine concern that values the person as a peer and not as an organizational position, and 4) an understanding that service toward helping another achieve success is service that benefits all.

The ability to discern which aspect of their own authenticity a situation or group requires is paramount (Goffee & Jones, 2005). Describing servant leadership as a way of “being” more than a practice, authors Boone and Makhani (2012) note *authenticity* and *presence* as among behaviors necessary of a servant-leader. Leaders who, in difficult circumstances, exhibit the cognitive and emotional skills to respond rather than react, exhibit mindfulness (Atkins, 2008). This may be considered *equanimity*. Gunaratana (2015) tells us that “the ultimate goal of our practice of meditation is the cultivation of these four sublime states of loving friendliness, compassion, appreciative joy, and equanimity” (p. 175). While one’s leader may have a personality trait of being even-keeled or even-tempered, servant-leaders pursue equanimity to best serve.

Servant-leaders may be described as scouts or coaches. Highly effective servant-leaders scout for potential and talent among those served (Boone & Makhani, 2012). When potential is spotted, the authors tell us, these servant-leaders are ardent in their commitment to develop that potential for success. More team-builder than star-maker, these effective servant-leaders are community builders. While an inherent desire to serve is fundamental to authenticity in servant-leaders, humility is the first step of personification for such leadership. Authors Hayes and Comer (2010) make a point of distinguishing humility as an absence of self-exaltation, rather than the more current Western definition as an absence of self-assertion. Humility does not weaken the leader. To the contrary, it encourages respect and trust among all group members. Humble leaders example this posture for their members. In mindfulness terminology, one may categorize the act of being cared for as *lovingkindness*, self-respect as being born of *self-compassion*, and trust as *acceptance*.

Humility emerges through a considered assessment of one's own imperfections, an acceptance of the task at hand and of its contributor, without attachment to self. Where ego evaluates others, humility evaluates logic (Covelli, 2018). Leaders who encourage the unique contribution of others, who are stewards of others' creativity, engender a supportive organizational culture that stimulates learning and fosters personal best (Zu, 2019). Zu writes, "Servant-leaders must have the power to activate goodness, build a high-trust organization, and transform the world through doing good" (p. 21). Authors Vargas and Hanlon (2007) report on the process of that transformation:

While we may at times be seen as barriers to activity, through developing solid relationships with our researchers and demonstrating our commitment to their needs, we can reduce the incidences of being seen merely as a policing function

and help to ensure that our offices are good stewards of the funds we administer.

(p. 3)

This sentiment illustrates scope and an in-situ expression of mindfulness principles in servant leadership organizations.

Wellbeing

In mindfulness, the wish for others' wellbeing is tempered by equanimity. It calls for proper balance and discernment as to what is within our or another's control (Goldstein, 2013). Servant leadership's mission expresses that aspirational desire in common with mindfulness: wellbeing. Organizational citizenship behaviors (OCBs) reported of members in servant leadership organizations include cooperation, care, and a climate of spirituality (Keith, 2015). Skill, effectiveness, and kindness in relationships at work are reported as reasons to seek out mindfulness (Gunaratana, 2015). The wellbeing of each of those served is a pillar of servant leadership, as is seeking the path to individual wellbeing in mindfulness. Organizations that seek out those precepts most enhancing of individual wellbeing realize organizational vitality. Goals of servant-leaders, for example, to shepherd their constituents to a more "felt and enriched" work life, agree with those same aspirations of mindfulness practice for a more enriched and equanimous life. OCBs exhibited to this end include enhanced self-efficacy, personal integrity, and optimism (Keith, 2015).

In their literature review, authors McKeage et al. (2020) tell us "Organizational culture is the most likely starting place for a firm to try to move towards increasing its overall servant leadership orientation" (p. 156). In the Forward section "What Leaders Say About Greenleaf and The Servant as Leader," Dr. Stephen Covey (2002) businessman, educator and renowned author of *The 7 Habits of Highly Effective People*, wrote, "...the only way you get empowerment is

through high-trust cultures and through the empowerment philosophy that turns bosses into servants and coaches...” By attending to worker wellbeing and happiness, to their sense of agency or empowerment, and to their self-confidence through encouragement and stewardship, servant-leaders help develop positive employee self-concepts. This results in constructive organizational behaviors such as motivation to work and is correlative to job performance and satisfaction (Tischler et al., 2016). This also exhibits servant leadership’s aspiration for holistic health for organizational members.

True understanding of the dyad of servant-leader allows servant leadership organizations to build a culture that accepts and values all members of its business community, encouraging “affective-based trust (instead of cognitive trust), thus focusing on nurturing of team members’ wellbeing” (Ahmed et al., 2017, p. 513). This cultural perspective is expressed throughout the very structure of servant leadership organizations:

Leaders whom we trust and want to follow achieve moral authority by being *servants* to followers and organizations, not by wielding titles or using coercive power. Moreover, entire institutions can act as servants. Every organization has a chart that shows who we are *to* each other, but servant leadership turns the chart upside down by focusing on how we are *for* each other. (Greenleaf Center for Servant Leadership, n.d., Greenleaf’s Best Test: Background section).

Ahmed et al. (2017) conducted a study examining the servant leadership hierarchy at various levels as influencing team creativity vis a vis identification with immediate servant-leader. The authors found, “Team leaders adopt the leadership style of top management, while followers identify with the team leaders with servant behavior, and ultimately resulting in high

team creativity” (pp. 511-512). In writing about servant leadership for their field of research administration, authors Vargas and Hanlon (2007) endorse the upside-down organizational chart of servant leadership organizations. The authors propose that “hierarchical authority no longer commands automatic respect; rather, respect that is given freely is needed to achieve real authority. Our new and under-acknowledged role of leadership must be earned in order to be most effective” (p. 46). Servant leadership eschews the “top of the pyramid” organizational chart which communicates that ultimate power builds up to and is exercised by only one person at the pinnacle. Servant leadership organizations, by inverting this pyramid, place the needs of the organization upon the leader as the starting point. The Greenleaf Center for Servant Leadership points out that “the servant-leader shares power, puts the needs of others first and helps people develop and perform as highly as possible” (n.d., What Is Servant Leadership: The Servant as Leader section).

Considering organizational identity, servant leadership stands out by placing the care taken by the servant-leader for meeting the needs of those served as primary (Akbari et al., 2014). Akbari et al. concur on two important measurements from the Greenleaf Best Test® that are particularly difficult to administer but which indicate servant leadership organizational success. The first concern is to determine if those served have grown as individuals. The second concern is to determine if those served have become their best selves and are themselves able to become servant-leaders. As shown in Figure 1, the conceptual model of their study on servant leadership and organizational identity, Akbari et al. tell us, “Servant leadership directly affects organizational identity and indirectly when mediated by job involvement. In addition, job involvement, also, has direct effects on organizational identity” (p. 47):

Figure 1

Conceptual model of relational effect: Job involvement, servant leadership, and organizational identity

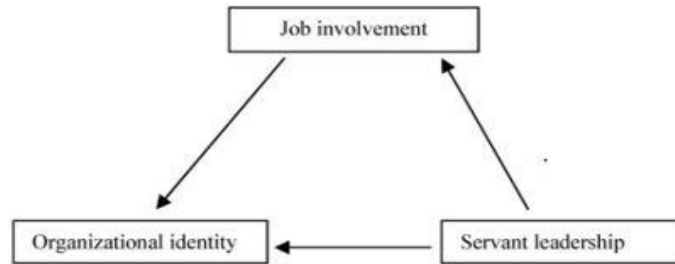

Note: Conceptual model of research. From Akbari, M., Kashani, S. H., Nikookar, H., & Ghaemi, J. (2014). Servant leadership and organizational identity: The mediating role of job involvement. *International Journal of Organizational Leadership*, 3(2), p. 47.

A servant leadership organization's success may be considered actionable compassion achieved. It may be considered profound empathy that facilitated another's wellbeing. If we incorporate a definition of genuine care and concern for another as compassion, His Holiness the Dalai Lama (2012) illuminates for us that our individual wellbeing, a fundamental aspiration of the practice of mindfulness, is especially realized by our compassion for others. He notes, "But whether we succeed in bringing benefit to others or not, the first beneficiary of compassion is always oneself,"(p. 45) adding that "Compassion reduces our fear, boosts our confidence, and brings us inner strength" (p.45). DeConinck et al. (2018) conducted a cross-sectional study of 382 business-to-business salespeople on the relationship between servant leadership, perceived organization support (POS), and turnover. POS was noted as particularly important to measure; servant-leaders appear to care for each employee profoundly, are proud of individual employee's achievements, and want to assist each individual employee when a problem arises for them. The authors note,

This perception that the organization supports their efforts will lead to higher performance and indirectly to lower turnover. Clearly, creating an environment where higher performance is achieved while reducing turnover, especially among the best performers, are goals that every organization wants to achieve regarding their sales force. (p. 47)

On analysis, DeConinck et al. (2018) found that servant leadership positively impacts POS and performance, and that POS was related positively to performance. In addition, contraindications were found for turnover intention and actual turnover. Turnover intentions were related negatively to turnover.

Corporate and organizational success with customers has been demonstrated positively in servant leadership organizations. Servant leadership impacts the culture of an organization, along with the commitment of that organization and OCBs. Ergo, customer satisfaction is impacted by the culture of servant leadership in that organization. In a 2017 study of 240 *handycraft* customers, author Setyaningrum (2017) found all measurements to be significantly and directly impacted by servant leadership:

Servant leadership has a positive correlation with employee commitment and organizational citizenship behavior, thus satisfying the customer. It is understood that the behavior of a leader who works to serve employees or followers, as well as upholding values such as empowerment, humility and empathy, will make the employees engage and loyal to the organization helping create a positive organizational culture. Thus, this paper conveys that servant leadership in organizational culture as well as organizational commitment and OCB has a strong positive influence on customer satisfaction. (p. 564)

Another variable of measurement for servant leadership organizational success is creativity, a highly valued quality in competitive business arenas. Hypothesizing creativity to emerge through identification with servant-leader relationally, the Ahmed et al. (2017) study surmised a direct correlation, as shown in Figure 2.

Figure 2.

Conceptual Model and Hypothesis: Identification with servant leadership at top and bottom level of organization on team creativity

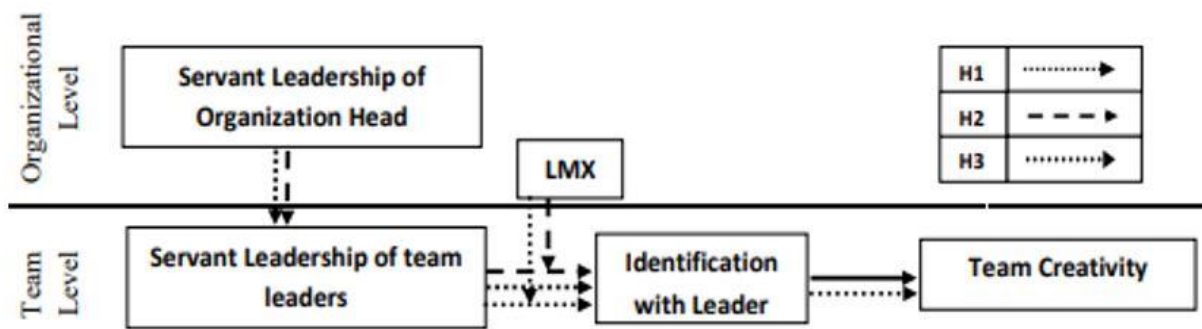

Note. Conceptual Model and Hypotheses. From Ahmed, I., Rehman, W. U., Khan, M.K., Ali, G., & Anwar, F. (2017). Bridging top and bottom multi-level model of servant leadership, identification with leader and team creativity. *Pakistan Economic and Social Review*, 55(2), p. 516). H1: Servant leadership of organizational head cascades to team leaders as they opt for the same leadership style, resulting in followers' identification with leader. H2: The relationship between servant leadership style of team head and followers' identification with leader is largely dependent upon their relationship in past; thus, high LMX may strengthen the association and vice versa. H3: Followers' identification with servant leader will foster their creativity (at all levels: individual, team and organizational) at workplace (p. 516).

Ahmed et al. (2017) tell us their results “provide the first evidence of the importance of servant leadership in promoting follower trust and representing the collective, which in turn foster employee creativity and team innovation” (p. 524). We can appreciate, intuitively, that for creativity to flourish, there needs to be an atmosphere of nurturance and acceptance. Nurturance and acceptance reflect the precepts of both servant leadership and mindfulness.

Greenleaf’s Best Test® (Greenleaf Center for Servant Leadership, n.d.) was designed and intended for servant leadership organizations to use throughout their pursuit of member wellbeing. The test allows servant leadership organizations to assess several particular areas from principle to practice: support of those being served with regard to their health and development, the success of its servant leadership principles being embodied and followed, and behaviors evidenced by those designated as servant-leader. This evaluation tool, unique to servant leadership, measures factors beyond the traditional profit/loss or growth percentages typically evaluated in organizations. The Best Test® evaluates “matters of heart, spirit, joy and community” (Greenleaf’s Best Test section). The Center offers their Best Test® in a 360 format, which is an advanced appraisal system to assess an employee via multi levels of feedback, i.e. those sharing in the work environment but not designated as direct manager. The Center also offers the test via employee survey. Van Dierendonck (2011) reported that followers experienced a higher quality of leader-member exchange (LMX) in a relationship with leaders motivated to serve. This motivation can be observed in the quality of the manager’s care. Servant-leaders strive to develop followers to their full potential. They partner with their employees toward goal performance and personal growth. Amah (2017) proposes, “Thus, servant leaders will be high in employee career enhancement and pro-social support behaviors” (p. 61). This bringing of deep

awareness to the needs of their employees integrates the mindfulness precept of present moment awareness and the aspiration of enhanced wellbeing.

In their study considering servant leadership's relationship to both core self-evaluation and to job satisfaction, Tischler et al. (2016) support the hypothesis that servant-leadership predicts higher job satisfaction: "Empirical studies have found that servant leadership is positively and significantly related to many outcome variables at the individual, team, and organizational levels" (p. 89) In a separate study of LMX mediation of servant leadership to job satisfaction, authors Akdol and Arikboga (2017) reported an equally positive correlation. Through building high-quality relationships with their subordinates, leaders positively impact job satisfaction. The authors add that "this is of practical importance because highly competitive and creative businesses rely on high ratings of JS as a competitive advantage. On the other hand, the field of SL moves from being prescriptive to becoming descriptive" (p. 533). We are also able to see this as correlative to mind-body health and, thus, positive psychological states. This leads to the wellbeing sought through the practice of mindfulness, in such precepts as community and openheartedness. The research model in Figure 2 presents the relational hypothesis.

Figure 3.

Research model of hypotheses: Relational effect of servant leadership (SL), job satisfaction (JS), and leader-member exchange (LMX)

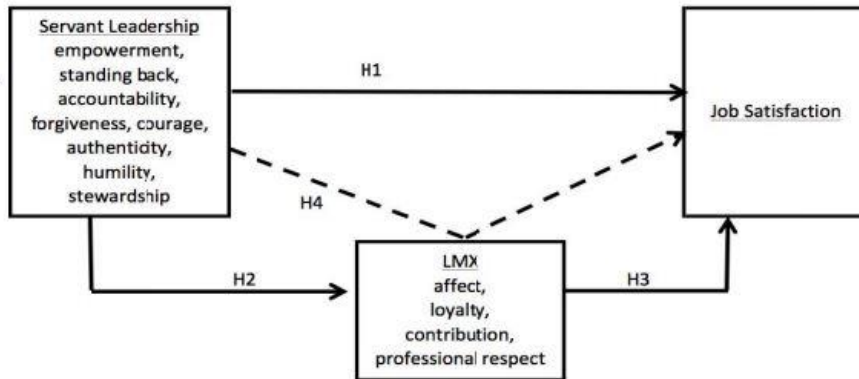

Note. Research model of hypotheses. Adapted from Akdol, B., & Arikboga, F. S. (2017). Leader member exchange as a mediator of the relationship between servant leadership and job satisfaction: A research on Turkish ICT companies. *International Journal of Organizational Leadership*, 6(4), pp. 525-535. H1: SL has significant and positive effect on overall JS; H2: SL has significant and positive effect on LMX; H3: LMS has significant and positive effect on overall JS; and H4: LMX has a partial mediating role on the relationship of SL and JS (p. 530).

Authors Rivkin et al. (2014) propose that servant leadership's positive relationship to employee psychological health is a direct result of the leadership model's cultural focus on fulfilling the needs of their employees. After having conducted two separate studies utilizing a multi-method approach, the authors report that both studies demonstrate that servant leadership reduces the negative correlates, such as stress. This ability of servant leadership to reduce the impact of more typical job stressors supports prosocial behaviors: "Accordingly, servant leadership can be regarded as an important determinant of employees' psychological health" (p. 52). Psychological wellbeing is important for the mindfulness aspiration of practicing equanimity and ending suffering. Among these precepts that seek to ease psychological suffering are Right Thought and awareness. Servant leadership organizations actively working to ease employees' stress and meeting their needs exhibits Right Action. Thus, Right Action promotes the

emergence of employee Right Thought and allows the space for employees to see things more clearly through an acceptance of self and of a situation. This equanimity allows the arising of discernment toward enhanced wellbeing. His Holiness, the Dalai Lama (2012), writing on the value of discernment, tells us discernment is more profound when combined with compassion. Compassion practiced with discernment is important for self-care and for being of true service. The two elements—compassion and discernment—provide a comprehensive approach toward ethics and spiritual wellbeing.

Spirituality and Morality

Outside of a recognition of its Buddhist roots, mindfulness does not carry a cultural identification with spirituality. Generally, mindfulness in the U.S. is secular. Yet spirituality is integrated within the practices and precepts of mindfulness. Among the 37 principles of enlightenment, *concentration* appears several times as a spiritual faculty or power. It is the last of the steps along the Noble Eightfold Path (Goldstein, 2013). The path is not one of spiritual ambition; rather, spiritual strength enhances mindfulness as well as concentration. All these aspects are interwoven as a mindful way of being in the world. Concentration enables awareness. Awareness allows being present. Being present yields a state of enhanced wellbeing. Merriam-Webster (2014) provides a definition that satisfies both a mindful interpretation and a secular view of the related term *spiritualizing*. Spiritualizing, the dictionary notes, is purifying from worldly influences that are corrupting. We may see servant leadership's guiding principle to develop employees holistically as a sort of spiritualizing. In addition, by exhibiting such qualities as humility and integrity, servant-leaders establish a climate conducive of both spiritualizing and spirituality among their team members (Keith, 2012).

Personal and spiritual growth are among the many applications of servant-leadership. Molano (2019) writes, “Studies on servant leadership have produced *multi-dimensional* characteristics: i.e., characteristics consisting of emotional, intellectual, social and spiritual dimensions, as well as constructs which include character traits, virtues, attitudes, behaviors, and competencies” (p. 82). Literature such as Molano’s article helps continue servant leadership’s placement beyond typical secular leadership guidelines. It is this element of spirituality that reminds one of presence and of acceptance. His Holiness, the Dalai Lama (2012) in his discourse on generosity of the heart tells us that “spiritual counsel, which entails offering comfort, concern, and advice to support others’ psychological and emotional wellbeing” (p. 150) shows generosity of the heart. He adds that “generosity is the most natural outward expression of an inner attitude of compassion and lovingkindness” (p. 149). We can see here that deep listening with an open and accepting heart-mind allows discernment. Practiced discernment can then lead to the nobler hypothesis. These intentions are integrated into servant leadership philosophy as spirituality and morality, argues Greenleaf (1970/2008):

A new moral principle is emerging which holds that the only authority deserving one’s allegiance is that which is freely and knowingly granted by the led to the leader in response to, and in proportion to, the clearly evident servant stature of the leader (Questions for Reflection section).

Sipe and Frick (2015) tell us servant-leaders establish moral authority through a consistency of humility, integrity, and a posture of spirituality. Further, self-awareness frames self-concept. Rather than leading through a position of serving, servant leaders are focused on *being* of service, only taking on the role of leader if it is conferred or necessary for the group in the commission of serving. Authors Sendjaya and Sarros (2002) tell us this primary intent of serving

must emanate from a self-concept of being moral and altruistic. His Holiness the Dalai Lama (2012) touches on this self-concept as well. He tells us that in Buddhism, the mental quality of self-respect conveys a self-concept of integrity and ethics. Together with the mental quality of deeply considering others, it allows a more sincere practice of awareness. The literature of servant leadership is considerable on the importance of caring for others. Greenleaf's better society rests on this fundamental purpose (Greenleaf Center for Servant Leadership, n.d). To begin the process of service, one must be first aware of the need.

Present Moment Awareness

More than any other practice or identifier of mindfulness, present moment awareness is the single most essential. It is at the core of the teachings and practices. Olendzki (2010) tells us it is a critical factor in how we respond to situations: "If we don't care to be present, unconscious decision-making systems will function by default to get us through to the next moment, albeit in the grips of (often flawed and suffering-causing) learned behaviors and conditioned responses" (p. 148). Greenleaf (1970/2008) concurs with this essential component of mindfulness and its value in servant leadership. "A qualification for leadership is that one can tolerate a sustained wide span of awareness so that he better 'sees it as it is'" (Awareness and Perception section), Greenleaf writes. For Greenleaf, awareness helped leaders garner valuable resources of clarity and experience to withstand stress and uncertainty. He acknowledged that although awareness leads to an inner serenity, it does not give solace. To the contrary, awareness disturbs and awakens.

Servant-leaders engage a heightened awareness that allows seeing the present moment as informed both empirically and with foresight (Sipe & Frick, 2015). In this way, we see servant leadership allowing that same state of the mind found through the practice of mindfulness.

Gunaratana (2015) counsels, “Meditation brings the mind to a state of tranquility and awareness, a state of concentration and insight” (p. 8). This practice in a systems environment is realized through deep listening. It is interesting to note that the 10 characteristics enumerated for servant leaders are not arranged in any order of importance except for listening. Listening is always the first characteristic identified. In interviewing Larry Spears, then President and CEO of the Robert K. Greenleaf Center for Servant Leadership, author Dittmar (2006) reports that Greenleaf believed strongly that the best servant-leaders were the best listeners. We see the mindfulness precept of awareness called into play with deep listening. Deep listening is the embodiment of present moment awareness and it is the spark for being of service. It is through awareness, the ability to profoundly sit and consider with concentration, revelations of need and how best to serve can emerge. Greenleaf (1970/2008) noted that by bringing awareness to a layer beyond the obvious, noticing the minutest things, we notice not only the grandness in more aspects of our work and life, we also see more leadership opportunities.

Acceptance

In considering acceptance, Greenleaf (1970/2008) quotes the Robert Frost (1914/2020) poem, “The Death of the Hired Man,” in which an errant and prodigal hired hand returns to a farming couple’s homestead to die. The aggrieved farmer husband stakes his position of conditional acceptance as he and his wife discuss welcoming the man home: “Home is the place where, when you have to go there, they have to take you in” (vv. 122-123). However, the farmer’s wife disagrees. She replies, “I should have called it Something you somehow haven’t to deserve” (vv. 124-125). It is telling that Greenleaf (1907/2008) found this passage and its exchange resonating. He advised that great leaders align with the farm wife’s position. Followers do not need to deserve the interest and affection of great leaders. For Greenleaf, all

people are tenderly flawed; affection and acceptance by degrees is a callous pursuit. Greenleaf chose to accept the human condition and the human being. He selects the definition of acceptance as open, unconditional receiving. In his essay's section devoted to acceptance, Greenleaf notes the antonym, rejection. This full consideration of acceptance and its opposite, non-acceptance, cuts more cleanly to Greenleaf's sentiment. It informs the servant leadership precept of acceptance. Great leaders, servant-leaders do not reject their followers even if they reject behaviors or, more specifically, set boundaries on behaviors. Mitchell (2014) tells us servant-leaders still hold others accountable, but the difference is that followers are invested in the metrics and thus take part in ownership.

Acceptance is one of the five ways of being a servant-leader to which authors Boone and Makhani (2012) refer. Rather than judge, servant-leaders empathize and seek ways to assist the healing of others. In hypothesizing servant leadership to have a significant and positive effect on ethical organizational climate, Topcu et al. (2015) identify three characteristics that embody acceptance: adopting risks, patience regarding outcomes, and tolerance for failure. Gunaratana (2015) tells us that in practicing mindfulness, the ego is transformed, and one becomes more accepting. Servant leadership, authors Sipe and Frick (2015) propose, "Demands heightened awareness, openness to transformation, and a willingness to supplement—and transcend—personal ego with an interest in and desire to understand others" (p. 85). The fear of being dismissed or ridiculed, of not being accepted as providing value, has long been pervasive in organizations that do not lead mindfully. It has been my personal observation that both the individual and the organization too often suffer because of a lack of acceptance.

Discussion

The concept of mindfulness and of servant leadership generally appeared on the national stage in the United States in the 1970s. The language of mindfulness—being present, awareness, acceptance, openheartedness—slowly made its way into the cultural lexicon. In business and organizational arenas, the vernacular of servant leadership—leading through service, inclusive decision making, authenticity—also emerged. Over the decades, countless books highlighting new leadership models appeared, challenging the all-serve-one, command-and-control power style of leadership, and numerous alternative philosophies have been proposed. Servant leadership theory was among the challengers. Some contenders, such as profound leadership and leader-member exchange theory, advocate for leadership actions that may fall under the purview of mindfulness. However, servant leadership is distinguished among organizational leadership theory by fundamentally adhering to mindfulness precepts in the very expression of its philosophy and by the depth of those precepts. The intersections of servant leadership philosophy with mindfulness philosophy are many. The underlying creed of servant leadership theory holds that servant leaders start with an inherent desire to serve, which then compels the leader within to rise to that better supposition and thus serve through leading (Greenleaf, 1970/2008). In this way, we see the very spark for the servant-leader to emerge as through Right Thought for the community or organization in which the servant-leader is constituent. Right Thought, Goldstein (2013) tells us, is one of the noble steps toward enlightenment in the practice of mindfulness. Right Thought allows compassion and a profound care for others in one's community or sangha to arise. Through a mindfulness interpretation, this compulsion to provide service for the betterment of the organization is Right Action and Right Livelihood. Goldstein tells us Right Action and Right Livelihood are steps along the Noble Eightfold Path of mindfulness practice

toward illumination and insight as well. Through the desire of servant-leaders to be of service we see Right Thought. Through the behaviors of servant-leaders we see Right Action. Through the servant leadership organizational commitment to Right Thought, Right Action, and community, we see Right Livelihood.

Servant leadership's abiding commitment to include and to lift all members of the organization in the day-to-day orchestration of the organization embodies the openheartedness and acceptance teachings of mindfulness. Organizationally, we see this sentiment expressed in the very hierarchy of servant leadership organizations. Leaders in servant leadership organizations do not lead by assumed power that radiates upward to an apex. Servant-leaders hold a foundational position, providing structure for communal input from the organization's members. *How* its servant-leaders interact with its members is more vital than *what* the leaders are to those members (Greenleaf Center for Servant Leadership, n.d.). This framework and the embrace of community anchors servant leadership as mindful and inclusive, reminding us of a monastic sangha providing support structurally and spiritually (Gethen, 1998). Community as sangha is, a priori, mindfulness in action.

Servant leadership's association with mindfulness precepts ranges throughout the literature from the biblical inferences of Molano (2019) to the secular coursework of Roberts (2017). In writing about servant leadership philosophy, authors use such terminology as presence (Boone & Makhani, 2012), awareness (Sipe & Frick, 2015), and acceptance (DeGraaf et al., 2013). In describing servant leadership in action, literature out of the Greenleaf Center for Servant Leadership (n.d.) is rife with such practices as deep listening and compassion. These terms—presence, awareness, acceptance, listening, compassion—are all found within the philosophy of mindfulness, as defined by Gunaratana (2015) and Goldstein (2013). But it is

community that most notably synergizes servant leadership as organizational mindfulness.

Servant leadership's steadfast embrace of community/members as interconnected and precious is the very reason for its being. Greenleaf (1970/2008) tells us that leadership is not assumed or bestowed at all in servant leadership organizations. It is conferred by the group to the servant leader from whom a deep desire to be of true service to that community through leadership arises. Servant-leaders begin with humility and serve not out of ego but out of morality and authenticity (Keith, 2012). Self-reflection is characteristic of servant-leaders, as opposed to the hubris often exhibited by leaders (Keith, 2015). Servant-leaders start with a sincere wish for each of the group's members to be holistically healthy and to grow positively in mind, body, and spirit. In mindfulness practice one aspires for wellbeing not only for oneself, but for the greater community of human beings. The Buddha described ardency as the long-enduring mind that sustained one on the path to enlightenment (Goldstein, 2013). One can see that for servant-leaders, ardency sustains their efforts much as it sustains spiritual practice in mindfulness.

Servant leadership further identifies itself as mindful through actions that embody mindfulness teachings. Within this study, I have highlighted certain of those practices, such as openheartedness, acceptance, awareness, and Right Thought/Right Action/Right Livelihood. These actions help to create a culture of spirituality and morality, both tenets of mindfulness practice (Goldstein, 2013). Dr. Kent M. Keith (2012) tells us that often when servant leadership is mentioned, an explanation of how it works is rarely noted. When asked why more organizations and people are not practicing servant leadership or are servant-leaders, Keith tells us, "People want to be effective and if they don't know enough about how they can be effective as servant-leaders, they may not be interested" ("If Servant Leadership Is so Effective" section). It has been my intention to provide not only examples of how servant leadership works, but to

illustrate how it is mindful in so doing. Keith adds that millions of people and groups practice servant leadership every day, quietly and without public recognition. By their very nature, servant-leaders are not self-promoting. Servant leadership philosophy does not seek the limelight for its work. It is not widely known in the business world even still. I, myself, had not heard of the philosophy until my coursework, yet I was led by a servant-leader manager who never disclosed a specific leadership theory. His mindful acts of listening, being present, and acceptance had a profound impact on our team. We had no doubt he wanted to help each of us discover our best self. He never made a special claim or sought accolades for doing so. Such is the nature of the quiet and profound work of servant-leaders. It is my personal optimism for more widespread awareness of servant-leaders and servant leadership philosophy that has propelled this work. Specifically, it is because servant leadership is mindful leadership that I took particular interest. Many years' experience working under the power model of leadership philosophy assures me that the very mindful theory of servant leadership can have a positive impact on organizations and institutions of every type.

Studies demonstrate the positive mediation of servant leadership relationships within organizations and toward employee success and wellbeing. This radiates throughout servant leadership organizations. Servant leadership organizational success is measured by the Robert K. Greenleaf Best Test®, a proprietary assessment tool that asks:

Do those served grow as persons? Do they, while being served, become healthier, wiser, freer, more autonomous, more likely themselves to become servants? And, what is the effect on the least privileged in society? Will they benefit or at least not be further deprived? (Greenleaf Center for Servant Leadership, n.d.).

We find this lovingkindness, this openheartedness, inextricably woven into the practice of mindfulness. Aspirational of servant leadership organizations is an outcome of enhanced wellbeing for its members, echoing this same desire of mindfulness practice. The research shows servant leadership organizations benefit thusly not only their community, but each individual participating in that community (Spears & Lawrence, 2004). This is demonstrated within mindfulness groups in various practices whereby members and their sangha may be whole and experience wellbeing (Goldstein, 2013). Paramount in mindfulness practice is compassionate care through presence and acceptance and the wish for another's happiness. Although Greenleaf may not have expressed it in the exact same way, the literature obliges us to see this very sentiment of mindfulness in his servant leadership philosophy and its practice.

During the production of this investigation, two additional principles continued to present as characteristic of both servant leadership and mindfulness: *morality*, and *spirituality*. I had not anticipated this and certainly had not expected both to be attributive in the specific. When I first encountered this commonality, I felt the word *moral* might be too fraught to include herein and that use of the term *spiritual* might mis-categorize this study. Morality insinuates judgment. Merriam-Webster (2014) defines *moral* as something one's conscience has sanctioned or something that passes judgement as ethical. Non-judgment has been identified as one of the main principles of both servant leadership and mindfulness and would seem oxymoronic to morality. On closer inspection, however, it is possible to be both non-judgmental and moral. Robert K. Greenleaf (1970/2008) did not parse words when he declared stewardship of the less fortunate a moral imperative of servant leadership. In his chapter on community, he wrote, "As soon as one's liability for another is qualified to any degree, love is diminished by that much" (Community—the Lost Knowledge section). Buddhist discourses, as well, advise to care for

those in need. Gethin (1998) tells us the very practice of monks begging for their sustenance assumes “sufficient good will on the part of those remaining in normal society to allow them to do so,” (p. 85). The use of the word moral has been attributed to various discourses by the Buddha. “It’s impossible to separate meditative wisdom from the moral understanding that makes it possible,” (Goldstein, 2013, p. 379). Right Action and Right Livelihood are part of the morality group Goldstein tells us. By this rubric, servant leadership seeks to express morality in its philosophy. Thus, servant leadership continues its expression of mindfulness.

Spirituality, the second principle that continued to present in the research on both servant leadership and mindfulness, is well evidenced within Buddhist teachings. “Mindfulness also works to balance what the Buddha called the ‘five spiritual faculties’: faith, energy, mindfulness, concentration, and wisdom,” according to Goldstein (2013, p. 15). Spears and Lawrence (2004) note, “The servant-leader recognizes the tremendous responsibility to do everything possible to nurture the personal, professional, and spiritual growth of employees” (Characteristics of the Servant-Leader section). The integration of a spiritual posture within servant leadership philosophy was revelatory and it provided additional rationale for servant leadership as mindful.

Lastly, I had presumed *forgiveness* to be an essential part of mindfulness practice yet was surprised to find it essential to servant leadership. Goldstein (2013) tells us that an enriching component to commence our mindfulness practice of meditation lies in extending forgiveness to others as well as to ourselves. Forgiveness may be the best application of a mindfulness precept integrated into servant leadership for 21st century organizations:

Forgiveness and reconciliation draw us into a crucible from which we can emerge more refined, more willing to see the heart of another and more able to create just and lasting relationships. The will to seek forgiveness, the will to forgive, and the

will to pursue reconciliation (instead of retribution) is a significant part of developing the kind of wisdom, health, autonomy, and freedom espoused by Greenleaf in his idea of the servant-leader for ourselves, for our families, and for our communities (Spears & Lawrence, 2004, Preface Section).

Implications for Further Research and for Servant Leadership in the 21st Century

I believe there is a global cultural energy seeking to synthesize social engagement, institutional responsibility, and personal empowerment. While current events and politics may seem overwhelmingly to work to divide us, a groundswell counter to that is arising. This counter effort acknowledges that we are all ultimately connected and may, therefore, be enriched by it. The better society about which Greenleaf (2004) wrote is starting to express itself in such movements as Black Lives Matter (BLM), Me, Too, and APA's fresh and inclusive gender language requirements. My study has focused on the assimilation of mindfulness principles into the language and behaviors of servant leadership organizations and their leaders. Implications for future research might be a comprehensive study of success metrics in current servant leadership organizations as overcoming implicit biases and more effectively embracing early-21st century movements such as BLM and Me, Too. Further promising research might be a study conducted with servant-leaders best able to identify in situ institutional processes that are still out of step with social inclusivity. Lastly, and particularly germane to this study, further research investigating mindful/servant leadership versus command-and-control leadership as shifting the paradigm toward community building would address current divisiveness and highlight compassion's effectiveness. Might we then better legislate through this more compassionate organizational model in our government institutions?

In an article examining several management styles for the 21st century, servant leadership stands apart for its focus on the growth, needs and wellbeing of those whom the servant-leader serves, rather than on personal advancement. Author Marques (2015) writes, “Given the many instances of self-centered and narcissistic leadership in recent years, this style may be an outstanding guide toward adjustment of our perspectives” (p. 1315). The lasting strength of servant leadership lies in its relevance. Its distinction lies in its profound message of service above self. Present trends in the field of communication include a focus on mindful communication as well as gender and leadership. Rather than communication as a simple transactional tool used by leadership, the methods and delivery of communication are being increasingly shaped by social implications (Cunningham et al., 2020). In a climate more demanding of co-creation, servant leadership is well positioned. It follows that for co-creation to exist, one must be responsive to the other’s needs and wants. It also follows that deep listening, a tenet of servant leadership and mindfulness, is conducive to this understanding and allowing. In their section on mindfulness practice integration for communication and leadership, Cunningham et al. (2020) suggest an exercise well suited to servant leadership, whereby role-play calls on listening as the prescribed communication exchange. This importance on listening certainly speaks to a mindfulness/servant leadership nexus.

Women in leadership still report having to exhibit different management styles for different situations. And they report having to do so more often than male counterparts in their organizations. Servant leadership calls for greater authenticity, regardless of gender, and does not require an aggressive or power stance of leadership that has come to be more associative of a male leadership style (Cunningham et al., 2020). Servant leadership philosophy confers strength by the trust servant-leaders earn through service. While servant leadership has occasionally been

insinuated as a more feminine or softer management style, this very point may be a non-starter as the culture becomes more fluid about gender and more accepting of non-binary identification. A leadership philosophy that encourages acceptance is well positioned for the early-21st century as welcoming of gender identification, physical or neurological diversity, and ethnic multiplicity:

The distinctive characteristics of servant-leaders lie first and foremost in their primary intent and self-concept. Servant leaders portray a resolute conviction and strong character by taking on not only the role of a servant, but also the nature of a servant (Sendjaya & Sarros, 2002, pp. 62-63).

In a world where all communication is suspect, servant leadership's desire for authenticity and compassion offers counterweight. Greenleaf (1970/2008) believed that in every era great men and women exist, working toward solutions for that era's problems and pointing "to a better way and to a 'personality' better able to live fully and serenely in these times" (Summoning and Articulating a Vision section). A wellspring of science supports compassion as inherent in and beneficial to all members of society, and therefore to society itself (Negi, 2018). We see this nature emerging in organizations such as the analytics software company Statistical Analysis System (SAS). SAS has instituted an interview process to accommodate those potentially qualified for certain technical jobs yet hindered by a neurodiversity that makes typical social or auditory interactions, such as job interviews, prohibitive (Matuson, 2019). In short, as we look toward the mid-century, organizations appear poised for a more mindful culture for their members. Organizations may endeavor toward that mindfulness culture most effectively through servant leadership.

Conclusion

Servant leadership serves as an example of mindful leadership in an organizational setting by its many adherences to precepts found in mindfulness theory. Creator of the servant leadership movement, Robert K. Greenleaf conceived of a leadership philosophy that openly embraced such fundamental mindfulness practices and pursuits as openhearted care of the (organizational) community, non-ego attachment in the commission of that care, and judgment generating from a humble posture of deep awareness of that community's members and their needs. The very composition of servant leadership organizations expresses a mindful community in which structure is provided but power is shared. Through such mindful behaviors as Right Thought, Right Action, and Right Livelihood, servant-leaders endeavor toward self-insight and wisdom that will lead to the wellbeing of the organizational community and ultimately society at large. By being present to those they serve with ardency, authenticity, and acceptance, servant-leaders integrate their dispositional mindfulness systemically. As societal and organizational will increasingly bends toward inclusivity and collective power, servant leadership is inherently poised to meet the call in a uniquely mindful way.

References

- Ahmed, I., Rehman, W. U., Khan, M.K., Ali, G., & Anwar, F. (2017). Bridging top and bottom multi-level model of servant leadership, identification with leader and team creativity. *Pakistan Economic and Social Review*, 55(2), 511-531.
- Akbari, M., Kashani, S. H., Nikookar, H., & Ghaemi, J. (2014). Servant leadership and organizational identity: The mediating role of job involvement. *International Journal of Organizational Leadership*, 3(2), 41-55.
- Akdol, B., & Arikboga, F. S. (2017). Leader member exchange as a mediator of the relationship between servant leadership and job satisfaction: A research on Turkish ICT companies. *International Journal of Organizational Leadership*, 6(4), 525-535.
- Albright, M. (2016). Servant leadership: Not just buzzwords. *Strategic Finance*, 98(4), 19-20.
- Amah, O. E. (2017). Leadership styles & relational energy in high quality mentoring relationship. *Indian Journal of Industrial Relations*, 53(1), 59-71.
- Atkins, P. (2008). Leadership as response not reaction: Wisdom and mindfulness in public sector leadership. Hart P. & Uhr J. (Eds.), *Public leadership: Perspectives and practices*. ANU Press, 73-82.
- Bassell, M. & Friedman, H.H. (2016). Ethical entrepreneurship is redefining marketing-driven organizations. *Journal of Ethics & Entrepreneurship*, 6(1), 97-116.
- Boone, L. W., & Makhani, S. (2012). Five necessary attitudes of a servant leader. *Review of Business*, 33(1), 83-96.
- Brandon, C. T. (2019). Be the trainer you want to have: Apply servant leadership concepts to talent development for lasting results. *TD Magazine*, 73(7), 70-71.

Covelli, B. J. (2018). Training authentic leaders: Research based application. *Global Journal of Management and Marketing*, 2(1), 28-37.

Covey, S.R. (2002). Forward. In R. Greenleaf, *Servant leadership: A journey into the nature of legitimate power and greatness*. The Greenleaf Center for Servant Leadership (25th Ed.). Paulist Press.

Cunningham, C. M., Hazel, M., & Hayes, T. J. (2020). Communication and leadership 2020: Intersectional, mindful, and digital. *Communication Research Trends*, 39(1), 4-31.

Dalai Lama (2012). *Beyond Religion: Ethics for a Whole World*. Houghton Mifflin Harcourt Publishing Company.

Davis, H. J. (2017). Discerning the servant's path: Applying pre-committal questioning to Greenleaf's servant leadership. *The Journal of Values-Based Leadership*, 10(2), 97-111.

DeConinck, J. B., Moss, H. K., & DeConinck, M. B. (2018). The relationship between servant leadership, perceived organizational support, performance, and turnover among business to business salespeople. *Global Journal of Management and Marketing*, 2(1), 38-52.

DeGraaf, D., Tilley, C. & Neal, L. (2013). Servant-leadership characteristics in organizational life. *Booklet 6*. The Greenleaf Center for Servant-Leadership.

Dittmar, J. K. (2006). An interview with Larry Spears: President & CEO for the Greenleaf Center for Servant Leadership. *Journal of Leadership & Organizational Studies*, 13(1), 108-118.

Fehr, R. & Gelfand, M.J. (2012). The forgiving organization: A multilevel model of forgiveness at work. *Academy of Management*, 37(4), 664-688.

Frost, R. (2020). The death of the hired man. *Poetry Foundation*.

<https://www.poetryfoundation.org/poems/44261/the-death-of-the-hired-man>.

- Gethen, R. (1998). *The Foundations of Buddhism*. Oxford University Press.
- Goldstein, J. (2013). *Mindfulness. A practical guide to awakening*. Sounds True, Inc.
- Greenleaf Center for Servant Leadership. (n.d.). <https://www.greenleaf.org>
- Greenleaf, R.K. (2002). *Servant leadership: A journey into the nature of legitimate power and greatness*. The Greenleaf Center for Servant Leadership (25th Ed.). Paulist Press.
- Greenleaf, R.K. (2008). *The servant as leader*. The Greenleaf Center for Servant Leadership. (Original work published 1970).
- Gunaratana, H. (2015). *Mindfulness in plain English*. Wisdom Press. (Original work published 2011).
- Hartranft, C. (2017, Summer). Foundations of contemplative practice: The Buddhist traditions. Lesley University, Cambridge, MA.
- Hayes, M. A. & Comer M. A. (2010). *Start with humility: Lessons from America's quiet CEOs on how to build trust and inspire followers*. The Greenleaf Center for Servant Leadership.
- Hesse, H. (2018). *The journey to the east*. Dead Authors Society. (Original work published 1932).
- Keith, K.M. (2012). *Questions and answers about servant leadership*. The Greenleaf Center for Servant Leadership.
- Keith, K M. (2015) *The case for servant leadership*. (2nd ed.). The Greenleaf Center for Servant Leadership.
- Linden, R.C., Wayne, S. J., Zhao, H., & Henderson, D. (2008). Servant leadership: Development of a multidimensional measure and multi-level assessment. *Leadership Quarterly*, 19(2),161–177.

- Marques, J. (2015). The changed leadership landscape: What matters today. *Journal of Management Development*, 34(10), 1310-1322.
- Matuson, R. (2019, October 30). *Hidden talent: The case for hiring neurodiverse candidates*. Forbes. <https://www.forbes.com/sites/robertamatuson/2019/10/30/hidden-talent-the-case-for-hiring-neurodiverse-candidates/#54731808768a>
- McClellan, J. L. (2013). On becoming a servant leader: A theoretical and philosophical basis for the emergence of natural servanthood. *The International Journal of Servant-Leadership*, 8/9(1), 87-105.
- McKeage, R. L., Giambatista, R. C., & Brees, J. R. (2020). Cultures of servant leadership and their impact. *The Journal of Values-Based Leadership*, 13(1), 155-172.
- Merriam-Webster (2014). Acceptance. In *Merriam-Webster Collegiate Dictionary*. (11th ed.).
- Merriam-Webster (2014). Community. In *Merriam-Webster Collegiate Dictionary*. (11th ed.).
- Merriam-Webster (2014). Moral, morality. In *Merriam-Webster Collegiate Dictionary*. (11th ed.).
- Merriam-Webster (2014). Spiritual. Spiritualizing. In *Merriam-Webster Collegiate Dictionary*. (11th ed.).
- Mitchell, J. W. (2014). What is servant leadership? *Kai Tiaki Nursing New Zealand*. 20(1), 18-19.
- Molano, R.M.N.V., (2019). The way of the servant citizen: Building mindfulness and reverence for work (BMW). *Leadership*. 12(1). 80-110.
- Negi, L. T. (2018). *Cognitively-based compassion training manual—prepared for teacher certification*. Emory-Tibet Partnership, Emory University.

Olendzki, A. (2010). *Unlimiting mind: The radically experiential psychology of Buddhism*.

Wisdom Publications.

Rivkin, W., Diestel, S., & Schmidt, K. (2014). The positive relationship between servant leadership and employees' psychological health: A multi-method approach. *Zeitschrift Für Personalforschung*, 28(1), 52-72.

Roberts, K. (2017, Fall). *Mindful Leadership and Conscious Social Change*. Lesley University, Cambridge, MA.

Sendjaya, S. & Sarros, J.C. (2002). Servant leadership: Its origin, development, and application in organizations. *Journal of Leadership & Organizational Studies*, 9(2), 57-64.

Setyaningrum, R. P. (2017). Relationship between servant leadership in organizational culture, organizational commitment, organizational citizenship behaviour and customer satisfaction. *European Research Studies*, 20(3A), 554-569.

Sipe, J.W. & Frick, D.M. (2015). *Seven pillars of servant leadership*. Paulist Press.

Spears, L.C. & Lawrence, M. (Eds.). (2004). *Practicing servant leadership: Succeeding through trust, bravery, and forgiveness*. Jossey-Bass.

Tischler, L., Giambatista, R., McKeage, R., & McCormick, D. (2016). Servant leadership and its relationships with core self-evaluation and job satisfaction. *The Journal of Values-Based Leadership*, 9(1), 85-105.

Topcu, M. K., Gursoy, A., & Gurson, P. (2015). The role of the servant leadership on the relation between ethical climate perception and innovative work. *European Research Studies* 18(1), 67-80.

Van Dierendonck, D. (2011). Servant leadership: A review and synthesis. *Journal of Management*, 37(4), 1228-1261.

- Vargas, P. A., & Hanlon, J. (2007). Celebrating a profession: The servant leadership perspective. *Journal of Research Administration*, 38(1), 45-48.
- Waring, N. (2017, Spring). *Mindfulness: Practice, theory, and science*. Lesley University, Cambridge, MA.
- Zu, L. (2019). Purpose-driven leadership for sustainable business: From the perspective of Taoism. *International Journal of Corporate Social Responsibility*, 4(1).