



## Calhoun: The NPS Institutional Archive

---

Faculty and Researcher Publications

Faculty and Researcher Publications Collection

---

1998-12

Absolute potential measurements inside microwave digital IC's using a micromachined photoconductive sampling probe

David, Gerhard

IEEE

---



Calhoun is a project of the Dudley Knox Library at NPS, furthering the precepts and goals of open government and government transparency. All information contained herein has been approved for release by the NPS Public Affairs Officer.

**Dudley Knox Library / Naval Postgraduate School**  
**411 Dyer Road / 1 University Circle**  
**Monterey, California USA 93943**

<http://www.nps.edu/library>

# Absolute Potential Measurements Inside Microwave Digital IC's Using a Micromachined Photoconductive Sampling Probe

Gerhard David, *Member, IEEE*, Tae-Yeoul Yun, Matthew H. Crites, John F. Whitaker, *Member, IEEE*, Todd R. Weatherford, *Member, IEEE*, Kay Jobe, Scott Meyer, Mario J. Bustamante, Bill Goyette, Stephen Thomas III, and Kenneth R. Elliott

**Abstract**— A measurement system for internal node testing of integrated circuits using a micromachined photoconductive sampling probe is described and characterized. Special emphasis is placed upon the system performance, demonstrating how absolute voltage measurements are achieved in a dc-to-mm-wave bandwidth. The feasibility of the setup is illustrated using an InP heterojunction bipolar transistor frequency divider. Detailed waveforms at different circuit nodes and the corresponding propagation delays from within this circuit at operating frequencies up to 10 GHz are presented. The results demonstrate for the first time the use of photoconductive probes for calibration-free, absolute-voltage, dc-coupled potential measurements in high-frequency and high-speed integrated circuits.

**Index Terms**— Integrated-circuit testing, microwave measurements, nondestructive testing, photoconductive measurements, time-domain measurements, voltage measurement.

## I. INTRODUCTION

**I**N RECENT years, different approaches for in-circuit measurement techniques for high-frequency and high-speed integrated circuits have been pursued. For example, electro-optic sampling [1]–[3] and electro-optic field mapping [4] have been successfully demonstrated. In addition, scanning probe microscopes [5], as well as electromagnetic probing techniques using dipole or monopole type probes [6], [7] have shown potential for making high-frequency in-circuit measurements. One aspect that all these measurement techniques have in

common is that they only yield relative values of the potential or electric field strength, so that calibration routines are necessary to determine actual absolute signal values. Moreover, the measurements are typically performed with ac-coupling [5], so that the dc component is not accessible. In contrast, we demonstrate in this paper that our recently developed measurement setup based on photoconductive sampling is capable of absolute measurement of the microwave signal amplitude at circuit-internal nodes. Thus, the signal's measured value is equal in size to its actual value, both for the dc and the ac component, and calibration routines are not necessary.

The photoconductive sampling technique has been used in the past for external port measurements of devices and circuits [8]–[10] with a bandwidth of several hundred gigahertz. This technique utilized picosecond electrical pulses generated by photoconductive switches and successfully measured the time domain characteristics of integrated devices under test (DUT's). Thus, it provided an alternative to the on-wafer network analyzer measurement technique but was exclusively limited to measurements of external ports. Miniaturized photoconductive probes (both micromachined and bulk) were then developed [11]–[16] to get access to arbitrary internal ports of integrated circuits. Bulk probes showed major limitations in ease-of-use and invasiveness, while micromachined probes revealed superior features because of the reduced parasitic capacitance and the flexible handling (e.g., fiber mounting of the probe is possible). The integration of a high impedance source follower as a readout circuit [14] has finally led to the probe embodiment used in this paper [15]. The readout circuit transforms the signal collection from a current measurement to a highly sensitive voltage measurement. This avoids leakage current to the probe and thus minimizes the circuit distortion. Absolute voltage levels are accessible because the parasitic capacitance of the sampling gate is significantly reduced. This also leads to an increased modulation bandwidth, providing higher signal-to-noise ratios, and sensing of electrical signals even through passivation layers [17] has been demonstrated.

The probes up to now have only been employed in pump-probe style experiments where an electrical signal is also generated by the same laser system used to provide the sampling triggers. This type of experiment is not appropriate under actual circuit driving conditions, where an independent electrical source must be employed. Thus, a heterodyne mixing

Manuscript received March 27, 1998; revised August 3, 1998. This work was sponsored by the National Science Foundation through the Center for Ultrafast Optical Science under STC PHY 8920108, by the AFOSR, Air Force Materiel Command, USAF, under Grant DOD-G-F49620-95-1-0027, and by the U.S. Navy under Contract N62271-97-M-1318. The work of G. David was supported by a Feodor Lynen Fellowship of the Alexander von Humboldt-Foundation, Germany.

G. David, T.-Y. Yun, M. H. Crites, and J. F. Whitaker are with the Center for Ultrafast Optical Science and the Department of Electrical Engineering and Computer Science, University of Michigan, Ann Arbor, MI 48109-2099 USA.

T. R. Weatherford is with the Department of Electrical and Computer Engineering, Naval Postgraduate School, Monterey, CA 93943 USA.

K. Jobe, S. Meyer, and M. J. Bustamante are with Hughes Electronics Corporation, Hughes Space and Communications Company, El Segundo, CA 90009 USA.

B. Goyette was with Hughes Electronics Corporation, Hughes Space and Communications Company, El Segundo, CA 90009 USA. He is now with TRW Avionics System Division, San Diego, CA 92128 USA.

S. Thomas III and K. R. Elliott are with HRL Laboratories, LLC, Malibu, CA 90765 USA.

Publisher Item Identifier S 0018-9480(98)09200-X.

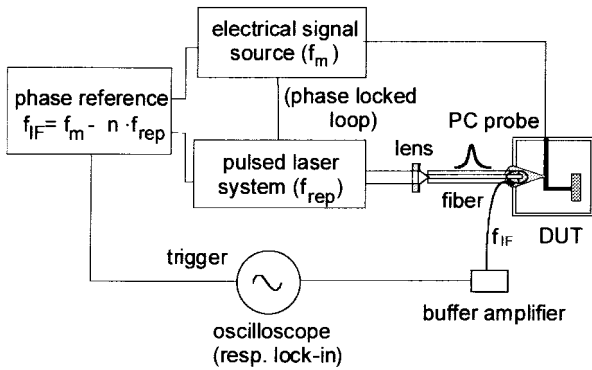

Fig. 1. Experimental setup for photoconductive in-circuit sampling measurements.

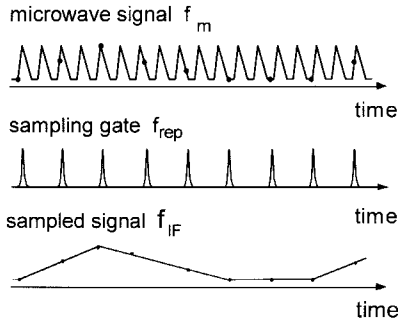

Fig. 2. Equivalent-time sampling scheme.

technique (for frequency-domain measurements) or an equivalent time sampling technique (for time-domain measurements) has to be used, requiring a synchronization between the gating laser pulse train and the independent, external electrical signal generator (i.e., a microwave synthesizer or an electrical pattern generator).

In this paper, the characteristics of the photoconductive probe along with those of the laser and the rest of the measurement system (e.g., bandwidth, sensitivity, spatial resolution, linearity for dc and ac operation) are discussed in relation to diagnostics of conventionally driven circuits. To highlight the capabilities, a digital frequency divider circuit operating between 90 MHz and 16 GHz has been investigated. Detailed waveforms that vary in shape and frequency at different nodes are presented, and propagation delays within the circuit are shown. The measured interconnect lines have widths down to  $3 \mu\text{m}$ , revealing the high spatial resolution of the probe. The results of these equivalent time sampling measurements demonstrate the usefulness of the probe, ranging from digital circuit diagnostics, model validation, and fault isolation, to characterization of in-circuit electrical transients such as those induced by cosmic particles in satellite microelectronics (so-called “single event effects”) [18], [19].

## II. SYSTEM DESCRIPTION

### A. Measurement Principle

The principal experimental setup is sketched in Fig. 1. Heterodyne-mixing and equivalent-time sampling (Fig. 2) require that the unknown signal repeats periodically with a

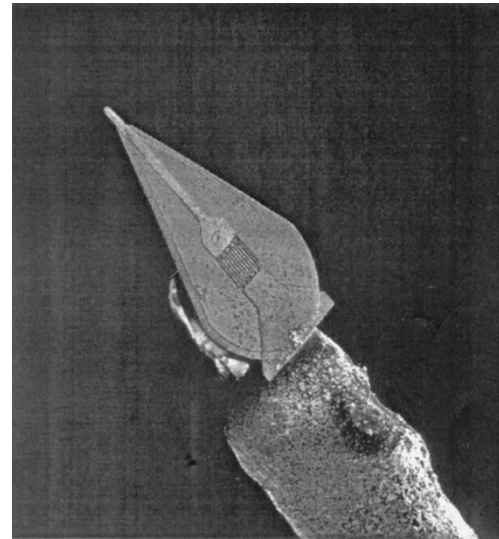

(a)

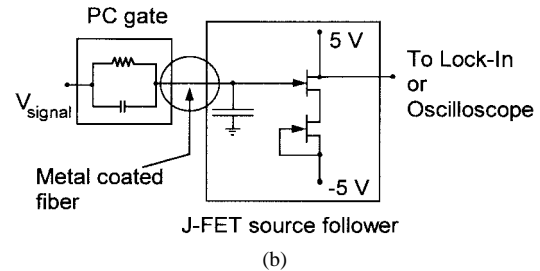

(b)

Fig. 3. Photoconductive sampling probe: (a) SEM image, (b) equivalent circuit; the probe is  $130 \mu\text{m} \times 230 \mu\text{m}$  (at its widest points) by  $1 \mu\text{m}$ . The finger size of the interdigital MSM switch is  $1.5 \mu\text{m}$ .

frequency  $f_m$ . If  $f_m$  is chosen to be

$$f_m = n \cdot f_{\text{rep}} \pm f_{\text{IF}}$$

where  $f_{\text{IF}}$  is an intermediate frequency (e.g., in the kilohertz-range, also called modulation frequency),  $n$  is an integer number, and  $f_{\text{rep}}$  is the repetition frequency of the sampling gates, then the signal will be sampled with the frequency  $f_{\text{IF}}$ , and a downconverted replica will appear at this frequency.

In the described measurement system, the sampling gates are provided by the photoconductive sampling probe. The probe is in conductive contact with a circuit internal node, where the unknown signal is to be measured. A train of femtosecond-duration laser pulses illuminates the probe, and its output voltage is recorded on a low-frequency electronic measurement instrument, such as an oscilloscope, making the temporal waveforms at the intermediate frequency accessible. A lock-in amplifier or a spectrum analyzer can also be used to display the amplitude and phase of  $f_{\text{IF}}$  and its harmonics, so that the unknown microwave signal can be determined in the frequency domain.

### B. Photoconductive Sampling Probe

The sampling probe used in this work consists of a micromachined epitaxial layer of low-temperature-grown GaAs [see Fig. 3(a)] attached to a single mode optical fiber that couples the laser pulses to a  $30 \times 30 \mu\text{m}^2$  interdigitated photoconductive sampling gate. The metal tip at the end of

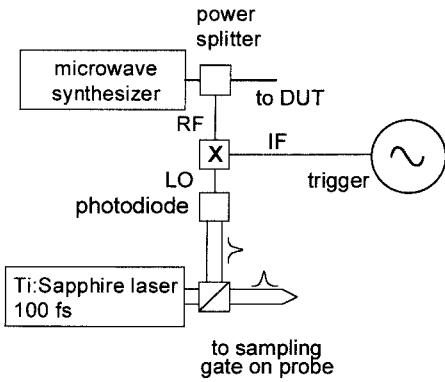

Fig. 4. Configuration for synchronization of a passively modelocked laser system and a microwave synthesizer.

the probe, which has a width of  $7\ \mu\text{m}$ , typically touches the circuit internal node to achieve a conducting contact.

The photoconductive gate has an off-state resistance of  $100\ \text{M}\Omega$ , which is comparable to the input impedance of commonly used readout instruments (e.g.,  $10\text{--}100\ \text{M}\Omega$  for a lock-in amplifier). Since this embodiment would lead to a current flow and to charge draining from the test point, the probe is instead integrated with a JFET source follower [see Fig. 3(b)] having an input impedance of  $1\ \text{T}\Omega$  and an input capacitance of  $3\ \text{pF}$ . This then acts as a readout circuit. The circuit avoids charge drainage from the DUT (currents are reduced to about  $3\ \text{pA}$ ), so that measurement with minimal invasiveness is achieved. Moreover, the current measurement is converted to a voltage measurement. Due to the low amount of charge necessary to load the source follower input, the actual voltage level is built up in a short time, allowing a higher modulation bandwidth and the ability to measure absolute voltage levels [14].

Due to the high input resistance of the source follower, the instantaneous dc voltage at the probe node is also present at the source follower and can be determined at the output of the source follower without significant degradation.

Because the optical input to the probe tip is via a fiber optic cable, it is easy to position the probe, and the compact cross section of the sampling head allows measurements even inside packaged circuits.

### C. Femtosecond Laser Systems

Two different pulsed laser systems have been used for the reported measurements. For both of them it is necessary to obtain synchronization between the laser pulse train and the external signal source (i.e., a microwave synthesizer). The laser systems used are as follows.

- 1) A passively modelocked Ti:Sapphire laser with a pulse duration of  $100\ \text{fs}$  and an average output power of  $2\ \text{W}$ . The synchronization of this free-running laser to the microwave synthesizer is obtained by the circuitry sketched in Fig. 4. The setup uses a phase referencing technique to synchronize the microwave signal source and the pulsed laser source in order to cancel out timing fluctuations. The reference signal is generated by an RF mixer with the local oscillator (LO) provided by the output signal of a fast photodiode and a fraction of the microwave

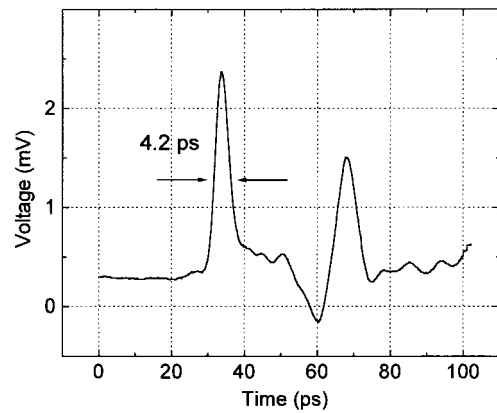

Fig. 5. Measured time response of the photoconductive probe (the negative transient and the subsequent positive pulse arise from reflections present on the coplanar strip photo switch).

signal used as the RF. The IF signal triggers a digitizing oscilloscope that records the downconverted waveform of the sampled microwave signal at the probed node, including the dc offset. This time synchronization is not perfect due to a timing jitter of about  $3\ \text{ps}$  caused by the laser. However, measurements of clock signals up to  $20\ \text{GHz}$  were still obtained from this system.

- 2) A more sophisticated model of the Ti:sapphire laser having  $80\text{-fs}$  pulse duration and  $1\ \text{W}$  output power. This laser also has phase-locked loop feedback electronics controlling the laser cavity length so that a highly stable  $80\text{-MHz}$  laser repetition rate and synchronization with an external oscillator are achieved. Phase-locking of the microwave synthesizer with this laser oscillator is possible via a  $10\text{-MHz}$  reference signal. Due to the feedback, the timing jitter of the passively modelocked laser is reduced to less than  $1\ \text{ps}$ , and measurements with low phase noise can be obtained. Using this laser system, the mixer configuration in Fig. 4 can be replaced by an additional low-frequency synthesizer that is phase-locked with both the laser pulse train and the microwave synthesizer.

### D. System Performance

1) *Time Resolution and Bandwidth:* The temporal resolution of the probe is measured using a pump-probe style of experiment. In this case, the Ti:sapphire laser system optoelectronically generates electrical pulses with durations of  $\sim 1\ \text{ps}$  on a coplanar strip line on a low-temperature grown GaAs substrate. Fig. 5 shows the voltage waveform measured by the probe. The excellent time response of  $t_{\text{FWHM}} = 4.2\ \text{ps}$  corresponds to a bandwidth of at least  $150\ \text{GHz}$  for this sampling system. That is, the probe should exhibit a frequency response well into the millimeter-wave regime.

2) *Modulation Bandwidth:* Without the source follower, the signal-to noise ratio for the photoconductive probe is optimized at an intermediate frequency  $f_I$  that is typically below  $1\ \text{kHz}$ . This limited bandwidth makes time-domain measurements at  $f_{\text{IF}}$  greater than  $\sim 100\ \text{Hz}$  impossible, and thus experiments have to be performed in the frequency range

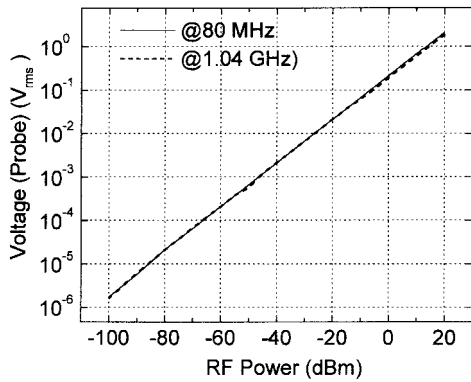

Fig. 6. Measured probe output voltage versus applied microwave power at two RF frequencies.

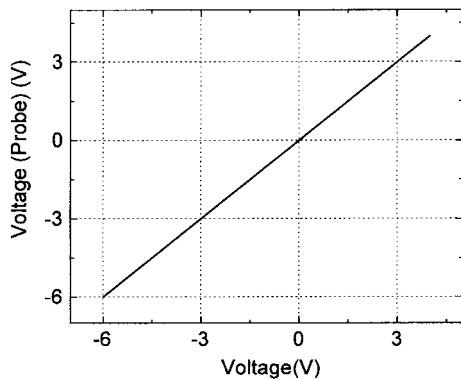

Fig. 7. Measured probe voltage versus applied input voltage.

where laser-induced noise, which has a  $1/f$  spectrum, is at its maximum. In contrast, the reduced parasitic capacitance of the probe with the source follower leads to an increase of the modulation bandwidth of two orders of magnitude [17]. In this case, an average laser power of only a few milliwatts is necessary to obtain absolute measurement of voltage within the DUT.

3) *Linearity*: Fig. 6 shows the measured probe voltage dependence on input microwave power at two different frequencies, revealing an excellent linearity over 12 decades. It was, however, necessary to calibrate the readout circuit, since the source follower exhibited a deviation up to 10% from the actual value for input voltages exceeding  $\pm 2.5$  V. This deviation was measured to be constant between dc and a frequency of 100 kHz, and could therefore easily be compensated within the data acquisition software. In addition to the ac component, the dc component (Fig. 7) also showed outstanding linearity with applied voltage.

4) *Sensitivity*: The overall noise level of the system sets a limit on the sensitivity of the photoconductive probe measurements. The main noise source is the amplitude fluctuation of the gating laser pulses. In the case of optimum conditions (i.e., minimized laser power), a sensitivity of approximately  $100 \text{ nV}/(\text{Hz})^{1/2}$  is achieved.

5) *Spatial Resolution*: The positioning of the  $7\text{-}\mu\text{m}$  width of the metal tip determines the spatial resolution of the probe used. This probe tip is sufficiently small that we may interrogate interconnects in many digital microwave circuits, even

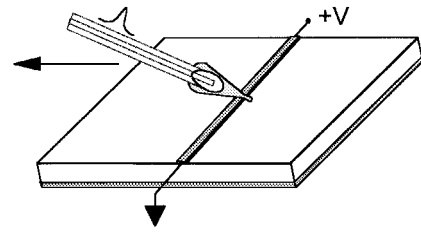

Fig. 8. Experimental setup for measurement of spatial resolution.

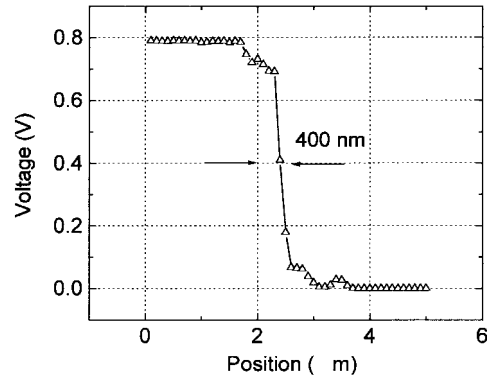

Fig. 9. Measured signal by translating the PC probe across the line.

with features much smaller than  $1 \mu\text{m}$ . It should be mentioned that decreasing the probe tip width could easily increase the resolution further, or a fine conical tip can be employed to access the submicrometer regime [9]. To demonstrate the limit for the resolution of the current probe, a transmission line with a width of  $5 \mu\text{m}$  was used as a DUT. The probe was translated transverse to the biased line using a high-precision translation stage ( $100 \text{ nm}$  minimal incremental motion) while the probe output voltage was measured (see Fig. 8). Fig. 9 shows the experimental result with a high signal level corresponding to the amplitude of the applied 1-GHz signal. This decreases to the system noise level when the probe tip loses the conductive contact with the line. The minimal overlap between the metal line and the probe tip that is required to still measure the absolute voltage on the transmission line is determined to be about  $400 \text{ nm}$ . Thus, even circuit nodes with submillimeter structure size are accessible by the probe tip, if the traces in a circuit are not packed too densely that the probe would overlap multiple lines and short them.

### III. CIRCUIT MEASUREMENTS

#### A. Device-Under-Test

The examined circuit is a high-speed, InP heterojunction bipolar transistor (HBT) frequency divider [20]. The circuit provides a differential divide-by-four output based on a differential input clock and is nominally designed to operate at 3.5 GHz. Internal dividers are based on latches constructed using differential pairs, where current is steered from one branch of the differential pair to the other to effect a change of logic state. The layout (Fig. 10) and the block diagram (Fig. 11) are annotated to show some of the probing locations. The device as configured was operated single-endedly, with one side of the differential input floated to its threshold. The single-ended

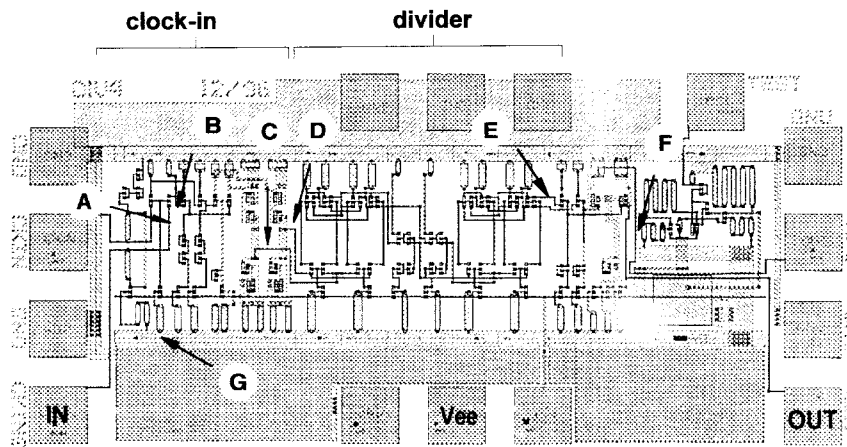

Fig. 10. Investigated InP frequency divider circuit with locations of probed nodes indicated.

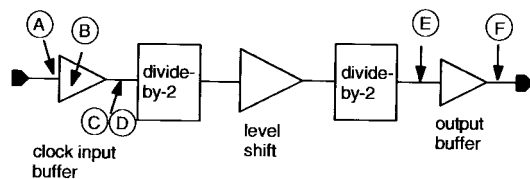

Fig. 11. Block diagram of InP divider circuit.

input was ac-coupled with dc biases set by internal circuit nodes.

### B. Circuit Characterization

Internal node measurements of the circuit up to 16 GHz were performed. While in [21] results at 2.7 GHz were demonstrated, here we present measurements at a significantly higher frequency of 10.56 GHz.

The single-ended input was probed at location (A) in Figs. 10 and 11, with results shown in Fig. 12(a). The 10.56-GHz sinusoidal input shows both the internal dc level and an input swing of 700 mV peak to peak. This value is consistent with an attenuation of 7 dB due to the connecting microwave cable and dc blocking capacitor (applied output power of the synthesizer was 6 dBm). Position (B), as shown on the layout in Fig. 10 and schematically in Fig. 11, yields a waveform that illustrates how the collector of the differential amplifier circuit operates single-endedly, where one differential pair transistor acts as an emitter-follower and the other is cut off. This causes a distortion of the sinusoid at that location. The ac component is 350 mV and the dc level is  $-0.2$  V. Note that a 7.1-ps propagation delay is measured between positions (A) and (B) corresponding to the expected transistor delay [after taking into account that the collector output (B) is inverted with respect to the emitter input (A)].

The differential output of the input clock buffer was probed at locations (C) and (D) as shown in the layout and block diagram. The results are shown in Fig. 13, where (C) is the true output and (D) is its complement. The phase inversion between the complementary outputs and the dc levels is as expected.

Two cascaded divide-by-two circuits create the divide-by-four function. Fig. 14 shows the second stage divide-by-two

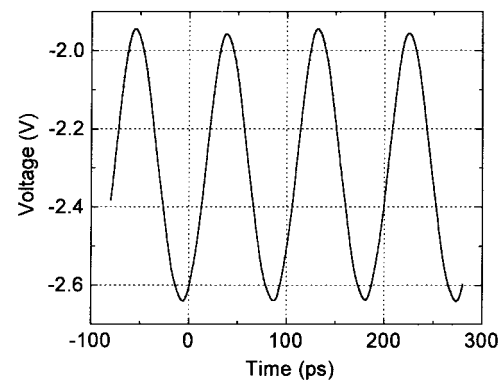

(a)

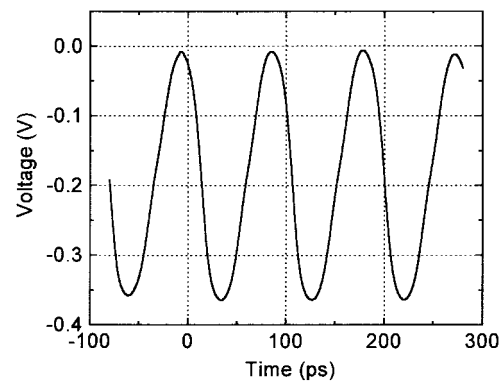

(b)

Fig. 12. Sinusoidal microwave input of 10.56 GHz, (a) measured at position (A), (b) measured waveform at position (B).

output probed at position (E) on the layout, revealing a frequency of 2.64 GHz ( $10.56 \text{ GHz}/4$ ). Fig. 15 shows the signal at the output buffer probed at position (F), with the same frequency of 2.64 GHz, as expected. The nonsinusoidal waveform indicates the presence of higher harmonics. When the circuit is operated at lower frequencies, for instance at its design frequency of 3.5 GHz, the higher harmonics completely transform the sinusoids to square waves [21]. Fig. 16 displays the characteristics of the noise on the power bus during the circuit operation. The bus has the expected  $-5.0$  V dc bias for Vee, but with a 50 mV peak-to-peak ripple.

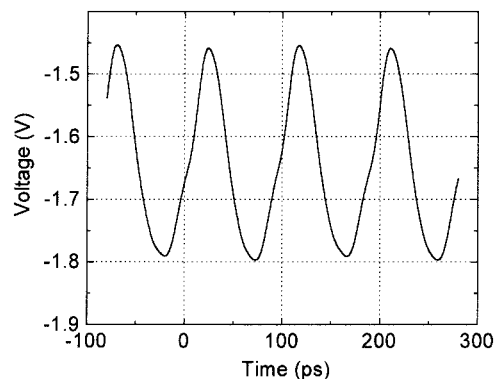

(a)

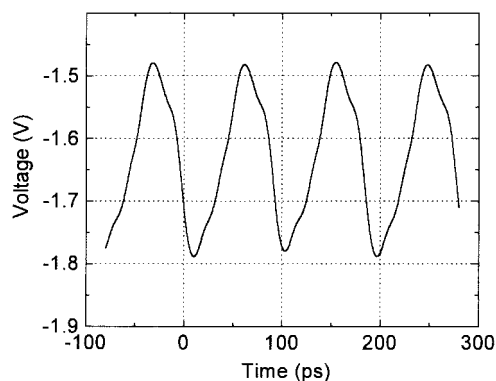

(b)

Fig. 13. (a) “True” output signal of the clock-input buffer section (position C), (b) complement output signal of the clock-input buffer at position D.

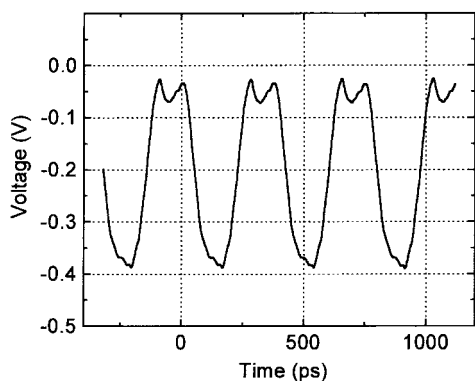

Fig. 14. Output signal of the second divide-by-two at position E (note the extended time axis).

#### IV. CONCLUSIONS

The in-circuit diagnostic capabilities of a measurement system using a micromachined photoconductive probe tip are presented. A discussion of the system performance has revealed high spatial resolution, high time resolution, and low interference with a microwave digital DUT-circuit. Special emphasis is placed on the fact that absolute voltages (both for dc and ac) are accessible from a probe having a bandwidth that exceeds 100 GHz. Internal node waveforms inside a microwave frequency divider circuit at a frequency of 10.56 GHz show the characteristic operation of the circuit (e.g., gate delays, frequency division, and power bus noise). The

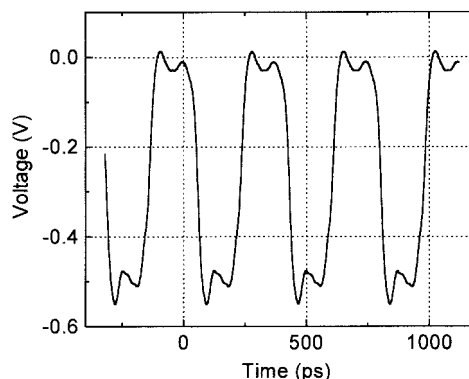

Fig. 15. Output signal of the output buffer at position F (note the extended time axis).

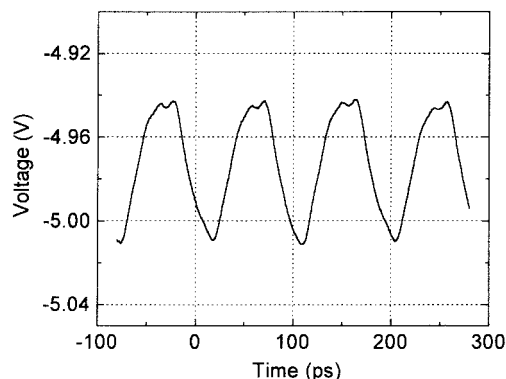

Fig. 16. Power bus noise at position G.

results demonstrate that the probe has a broad potential as a diagnostic tool in IC testing, particularly for digital circuits as they push up toward millimeter-wave operating frequencies. Furthermore, the probe should also provide a novel capability for validation of circuit models as they become increasingly complex and cover higher frequencies of operation.

#### REFERENCES

- [1] J. Valdmanis and G. Mourou, “Subpicosecond electrooptic sampling: Principles and applications,” *IEEE J. Quantum Electron.*, vol. QE-22, pp. 69–78, Jan. 1986.
- [2] B. H. Kolner and D. M. Bloom, “Electrooptic sampling in GaAs integrated circuits,” *IEEE J. Quantum Electron.*, vol. QE-22, pp. 79–93, Jan. 1986.
- [3] M. J. W. Rodwell, M. Riazat, K. J. Weingarten, B. A. Auld, and D. M. Bloom, “Internal microwave propagation and distortion characteristics of a traveling-wave amplifier studied by electrooptic sampling,” *IEEE Trans. Microwave Theory Tech.*, vol. MTT-34, pp. 1356–1362, Dec. 1986.
- [4] G. David, R. Tempel, I. Wolff, and D. Jäger, “Analysis of microwave propagation effects using 2D electro-optic field mapping techniques,” *Opt. Quantum Electron.*, vol. 28, pp. 919–931, July 1996.
- [5] A. S. Hou, B. A. Nechay, F. Ho, and D. M. Bloom, “Scanning probe microscopy for testing ultrafast electronic devices,” *Opt. Quantum Electron.*, vol. 28, pp. 819–841, July 1996.
- [6] T. Budka, S. D. Waclawik, and G. Rebeiz, “A coaxial 0.5–18 GHz near electric field measurement system for planar microwave circuits using integrated probes,” *IEEE Trans. Microwave Theory Tech.*, vol. 44, pp. 2174–2183, Dec. 1996.
- [7] Y. Gao and I. Wolff, “A new miniature magnetic field probe for measuring three-dimensional fields in planar high frequency circuits,” *IEEE Trans. Microwave Theory Tech.*, vol. 44, pp. 911–918, Dec. 1996.

- [8] D. E. Cooper and S. C. Moss, "Picosecond optoelectronic measurement of the high frequency scattering parameters of a GaAs FET," *IEEE J. Quantum Electron.*, vol. QE-22, pp. 94-100, Jan. 1986.
- [9] H. L. A. Hung, P. Polak-Dingels, K. J. Webb, T. Smith, H. C. Huang, and C. H. Lee, "Millimeter-wave monolithic integrated circuit characterization by a picosecond optoelectronic technique," *IEEE Trans. Microwave Theory Tech.*, vol. 37, pp. 1223-1231, Aug. 1989.
- [10] M. Matlobian, H. Fetterman, M. Kim, A. Oki, J. Camou, S. Moss, and D. Smith, "Picosecond optoelectronic measurement of S-parameters and optical response of an AlGaAs/GaAs HBT," *IEEE Trans. Microwave Theory Tech.*, vol. 38, pp. 683-686, May 1990.
- [11] J. Kim, S. Williamson, J. Nees, S. Wakana, and J. F. Whitaker, "Photoconductive sampling probe with 2.3 ps temporal resolution and 4  $\mu$ V sensitivity," *Appl. Phys. Lett.*, vol. 62, pp. 2268-2270, May 1993.
- [12] J. Nees, S. Wakana, and S. Hama, "Ultrafast-ultrafine probing of high-speed electrical waveforms using a scanning force microscope with photoconductive gating," *Opt. Quantum Electron.*, vol. 28, pp. 843-865, July 1996.
- [13] T. Pfeifer, H.-M. Heiliger, E. Stein von Kaminski, H.G. Roskos, and H. Kurz, "Fabrication and characterization of freely positionable silicon-on-sapphire photoconductive probes," *J. Opt. Soc. Am. B*, vol. 11, pp. 2547-2552, Dec. 1994.
- [14] J.-R. Hwang, H.-J. Cheng, J. F. Whitaker, and J. V. Rudd, "Photoconductive sampling with an integrated source follower/amplifier," *Appl. Phys. Lett.*, vol. 68, pp. 1464-1466, Aug. 1996.
- [15] R. K. Lai, J.-R. Hwang, J. Nees, T. B. Norris, and J. F. Whitaker, "A fiber-mounted, micromachined photoconductive probe with 15nV/Hz<sup>1/2</sup> sensitivity," *Appl. Phys. Lett.*, vol. 69, pp. 1843-1845, Sept. 1996.
- [16] K. Takeuchi and A. Mizuhara, "Potential image observation with ultra-high space-time resolution," in *Ultrafast Electronics and Optoelectronics, Tech. Dig.*, Optical Society of America, Washington, D.C., 1997, pp. 151-153.
- [17] J. R. Hwang, H. J. Cheng, and J. F. Whitaker, "Modulation bandwidth and noise limit of photoconductive gates," *Opt. Quantum Electron.*, vol. 28, pp. 961-973, July 1996.
- [18] E. Ledbetter, T. Weatherford, G. David, J. Hayden, R. Lai, and J. Whitaker, unpublished.
- [19] G. David, J. Whitaker, E. Ledbetter, T. Weatherford, D. Fouts, W. Goyette, K. Jobe, and K. Elliott, "A picosecond-response photoconductive-sampling probe for digital circuit testing," in *IEEE LEOS '97 Conf. Dig.*, San Francisco, CA, Nov. 1997, pp. 236-237.
- [20] J. F. Jensen, W. E. Stanchina, R. A. Metzger, D. B. Rensch, R. F. Lohr, R. W. Quen, M. W. Pierce, Y. K. Allen, and P. F. Lou, "AlInAs/GaInAs HBT IC technology," *IEEE J. Solid-State Circuits*, vol. 26, pp. 415-421, Mar. 1991.
- [21] G. David, J. F. Whitaker, T. R. Weatherford, K. Jobe, S. Meyer, M. Bustamante, W. Goyette, S. Thomas III, and K. Elliott, "DC-to-mm-wave absolute potential measurements inside digital microwave IC's using a micromachined photoconductive sampling probe," in *1998 IEEE MTT Int. Microwave Symp. Dig.*, pp. 1333-1336.



**Gerhard David (M'97)** received the Diplom-Physiker degree from the Georg-August University, Goettingen, Germany, in 1991 and graduated as a Doctor in Engineering (Dr.-Ing.) from the Gerhard-Mercator-University Duisburg (Institute of Optoelectronics), Germany, in 1996.

Since 1997 he has been a Research Fellow at the Center for Ultrafast Optical Science and the Radiation Laboratory (Department of Electrical Engineering and Computer Science), The University of Michigan, Ann Arbor. His research interests

are in the development of ultrafast photoconductive and electro-optic measurement techniques for testing and characterization of high-frequency and high-speed integrated circuits, antennas, and optoelectronic devices. Currently he is working on optical-based techniques for simulation and characterization of space radiation effects in satellite-based digital electronics and imaging of near-field distributions of millimeter-wave antennas, antenna arrays, and quasi-optical power combiners. He has authored or co-authored more than 30 papers in the field of electro-optic sampling and microwave optoelectronics.

In 1993 Dr. David was awarded the EuMC Microwave Prize of the 23rd European Microwave Conference, and in 1997 he became a fellow of the Alexander von Humboldt-Foundation, Germany.



**Tae-Yeoul Yun** received the B.S.E.E. degree from the Kyung-pook National University, Korea, in 1987 and the M.S.E.E. degree from KAIST (Korea Advanced Institute of Science and Technology) in 1989.

From 1989 to 1996 he worked for the Optical Telecommunication System Group, ETRI (Electronics and Telecommunications Research Institute), Korea. From 1997 to 1998 he worked for EECSS Department of the University of Michigan, Ann Arbor, as a Research Assistant. Currently he is working as a Research Assistant and toward the Ph.D. degree at the Electromagnetics and Microwave Laboratory, Electrical Engineering Department, Texas A&M University, College Station. His research interests are the microwave, millimeter-wave, and optical telecommunication devices, systems, and networks.



**Matthew H. Crites** was born near Chicago, IL, in 1974. He received the B.S. degree in electrical engineering from Boston University, Boston, MA, in 1996 and the M.S. degree in electrical engineering from the University of Michigan, Ann Arbor, in 1998. He is currently working toward the Ph.D. degree at the Center for Ultrafast Optical Science at the University of Michigan.

His research interests include using ultrafast optics to examine the effects of space radiation on electronic devices.

Mr. Crites is a member of Tau Beta Pi.



**John F. Whitaker (S'84-M'88)** received the B.Sc. degree in physics from Bucknell University, Lewisburg, PA, in 1981, and the M.Sc. and Ph.D. degrees in electrical engineering from the University of Rochester, Rochester, NY, in 1983 and 1988, respectively.

After serving as a Research Fellow at the Laboratory for Laser Energetics, University of Rochester, he joined the faculty of the Department of Electrical Engineering and Computer Science, University of Michigan at Ann Arbor, in 1989. He is currently an Associate Research Scientist and Coordinator of the Ultrafast Technology Area, NSF Center for Ultrafast Optical Science. In 1995, he was also appointed Visiting Professor, First Class, at the University of Savoie, France. His research interests involve ultrafast-response optoelectronic materials, devices, and test and characterization techniques. He has published over 80 papers and book chapters in the technical literature.

Dr. Whitaker became chair of the IEEE Lasers and Electro-Optics Society (LEOS) Technical Committee on Ultrafast Optics and Electronics in 1998. He was a recipient of the 1996 IEEE Microwave Theory and Techniques Society Microwave Prize.





**Todd R. Weatherford** (S'82-M'90) was born in Camden, NJ, in 1961. He graduated with the B.S.E.E. degree from Rutgers University in 1983 and the M.S.E.E. and Ph.D. degrees from North Carolina State University (NCSU) in 1986 and 1992, respectively.

He has held positions at RCA Broadcast Systems in video camera design and RCA Advanced Technology Laboratories in CMOS/SOS and GaAs IC design. In 1984 he was a Research Assistant in the NCSU Solid State Laboratory studying single event upset effects in GaAs IC's. In 1990 he joined the Naval Research Laboratory's Radiation Effects Branch where he investigated MESFET and HBT charge collection effects and conducted accelerator and space-based experiments. In 1995 he joined the faculty as an Assistant Professor at the Naval Postgraduate School where he is presently developing radiation immune technologies in group IV and III/V semiconductors.

Dr. Weatherford has recently been awarded the NPS 1997 Research Achievement in the electrical and computer engineering department. He is a member of the IEEE Nuclear Science Society, Solid-State Circuits Society, and Electron Device Society and TMS. He has served on conference committees and reviewed for IEEE publications. He has authored and co-authored over 45 publications.



**Kay Jobe** received the B.S.E.E. degree from the University of Colorado in 1980.

She started working at Hughes upon completion of B.S.E.E. degree. She has managed various projects during her career there involving the development and application of new technologies in space, including hardened acoustic memories and digital GaAs. She has more recently been involved in the characterization of radiation performance of very high-speed digital devices for space-borne applications.



**Scott Meyer** received the B.S. degree in electronics engineering technology from the DeVry Institute, Phoenix, AZ, in 1987.

In 1987 he joined Hughes Electronics, Hughes Space and Communications, Los Angeles, CA, as a Staff Engineer. His previous work has included flight production for Milstar LDR program and R&D for advanced frequency synthesis. His current work emphasis is on high data rate clock and data recovery as member of the High Speed ASIC Development Team.



**Mario J. Bustamante** received the B.S. degree in electrical engineering and computer science from the University of California, Berkeley, in 1981 and the M.S. degree in electrical engineering from Loyola Marymount University, CA, in 1988.

Since 1982, he has been with Hughes Space & Communications, El Segundo, CA, and is presently managing the development of very-high-speed ASIC's. His previous work has included the research and development of wideband Ku-band synthesizers, RF PWB's, direct digital synthesizers,

and digital-to-analog converters.

Mr. Bustamante received one individual and two group Hughes Telecommunication and Space Company technical excellence awards for contributions to synthesizer and high-speed ASIC development efforts in 1993, 1995, and 1997.



**Bill Goyette** received the B.S. degree in engineering physics from the University of San Francisco, San Francisco CA, in 1983 and the M.S.E.E. degree from Loyola Marymount University, Los Angeles, CA, in 1987.

He was with Hughes Electronics, Space and Communications, Los Angeles, CA, from 1983-1997 as a Senior Staff Engineer working on Milstar LDR and MDR, UHF F/O and UHF F/O EHF programs. He was also a part of the High Speed ASIC development team. He has been with TRW Avionics Systems Division, San Diego, CA, since 1997 as a Senior RF Design Engineer where he is currently supporting IR&D technology development programs.

**Stephen Thomas III** received the B.S.E.(E.E.) degree in 1992, the M.S.E.(E.E.) degree in 1993, and the Ph.D. degree in 1997 all from the University of Michigan, Ann Arbor.

At the University of Michigan, he developed *in situ* diagnostics for real-time control of advanced dry etch processes. He also used e-beam lithography and dry etching to fabricate structures with high aspect ratio and nanometer scale linewidths. He joined HRL Laboratories in 1997, where he is currently a research scientist. His job assignments include work on process development for GaInAs/AlInAs-based HBT IC's and InP HEMT's.

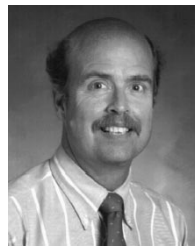

**Kenneth R. Elliott** received the Ph.D. degree from the California Institute of Technology, Pasadena, in 1979.

He has pioneered the development of III-V semiconductor integrated circuit technology for the past 17 years. From 1980 to 1993, he was a Scientist at the Rockwell International Microelectronics Research Center. Since 1993, he has been a project manager at HRL Laboratories in Malibu, CA. Throughout his career, he has been pivotal in transferring III-V technology from laboratory environments to commercial prototype production. He provides technical expertise in diverse areas including device engineering, electronic materials for advanced devices, integrated circuit design, process development of advanced device structures, device modeling, radiation effects, and CAD. His current technical interests include the development of *in situ* monitoring and control techniques for the growth of device structures using MOVPE, the development of ultra-high-performance IC's using advanced devices, and the development of new approaches to multifunctional integrated circuits.

Dr. Elliott is a member of Phi Beta Kappa.