



2015-06

Organic over-the-horizon targeting for the 2025 surface fleet

Johnson, Cale

Monterey, California: Naval Postgraduate School

<http://hdl.handle.net/10945/45933>



Calhoun is a project of the Dudley Knox Library at NPS, furthering the precepts and goals of open government and government transparency. All information contained herein has been approved for release by the NPS Public Affairs Officer.

Dudley Knox Library / Naval Postgraduate School
411 Dyer Road / 1 University Circle
Monterey, California USA 93943

<http://www.nps.edu/library>



**NAVAL
POSTGRADUATE
SCHOOL**

MONTEREY, CALIFORNIA

**SYSTEMS ENGINEERING ANALYSIS
CAPSTONE PROJECT REPORT**

**ORGANIC OVER-THE-HORIZON TARGETING FOR
THE 2025 SURFACE FLEET**

by

Team Alpha
Cohort 21

June 2015

Project Advisors:

Timothy Chung

Approved for public release; distribution is unlimited

**Please note that this activity was not conducted in accordance with Federal, DOD,
and Navy Human Research Protection Regulations**

THIS PAGE INTENTIONALLY LEFT BLANK

REPORT DOCUMENTATION PAGE			<i>Form Approved OMB No. 0704-0188</i>	
Public reporting burden for this collection of information is estimated to average 1 hour per response, including the time for reviewing instruction, searching existing data sources, gathering and maintaining the data needed, and completing and reviewing the collection of information. Send comments regarding this burden estimate or any other aspect of this collection of information, including suggestions for reducing this burden, to Washington headquarters Services, Directorate for Information Operations and Reports, 1215 Jefferson Davis Highway, Suite 1204, Arlington, VA 22202-4302, and to the Office of Management and Budget, Paperwork Reduction Project (0704-0188) Washington DC 20503.				
1. AGENCY USE ONLY (Leave blank)		2. REPORT DATE June 2015	3. REPORT TYPE AND DATES COVERED Capstone Project Report	
4. TITLE AND SUBTITLE ORGANIC OVER-THE-HORIZON TARGETING FOR THE 2025 SURFACE FLEET			5. FUNDING NUMBERS	
6. AUTHOR(S) Systems Engineering Cohort 21/Team Alpha				
7. PERFORMING ORGANIZATION NAME(S) AND ADDRESS(ES) Naval Postgraduate School Monterey, CA 93943-5000			8. PERFORMING ORGANIZATION REPORT NUMBER	
9. SPONSORING /MONITORING AGENCY NAME(S) AND ADDRESS(ES) N/A			10. SPONSORING/MONITORING AGENCY REPORT NUMBER	
11. SUPPLEMENTARY NOTES The views expressed in this thesis are those of the author and do not reflect the official policy or position of the Department of Defense or the U.S. Government. IRB Protocol number ____N/A____.				
12a. DISTRIBUTION / AVAILABILITY STATEMENT Approved for public release; distribution is unlimited			12b. DISTRIBUTION CODE	
13. ABSTRACT (maximum 200 words) Adversarial advances in the proliferation of anti-access/area-denial (A2/AD) techniques requires an innovative approach to the design of a maritime system of systems capable of detecting, classifying, and engaging targets in support of organic over-the-horizon (OTH) tactical offensive operations in the 2025–2030 timeframe. Using a systems engineering approach, this study considers manned and unmanned systems in an effort to develop an organic OTH targeting capability for U.S. Navy surface force structures of the future. Key attributes of this study include overall system requirements, limitations, operating area considerations, and issues of interoperability and compatibility. Multiple alternative system architectures are considered and analyzed for feasibility. The candidate architectures include such systems as unmanned aerial vehicles (UAVs), as well as prepositioned undersea and low-observable surface sensor and communication networks. These unmanned systems are expected to operate with high levels of autonomy and should be designed to provide or enhance surface warfare OTH targeting capabilities using emerging extended-range surface-to-surface weapons. This report presents the progress and results of the SEA-21A capstone project with the recommendation that the U.S. Navy explore the use of modestly-sized, network-centric UAVs to enhance the U.S. Navy’s ability to conduct surface-based OTH tactical offensive operations by 2025.				
14. SUBJECT TERMS Maritime ISR, Distributed Lethality, Surface Warfare, Surface Action Group, Organic Over-The-Horizon Targeting, 2025			15. NUMBER OF PAGES 213	
			16. PRICE CODE	
17. SECURITY CLASSIFICATION OF REPORT Unclassified	18. SECURITY CLASSIFICATION OF THIS PAGE Unclassified	19. SECURITY CLASSIFICATION OF ABSTRACT Unclassified	20. LIMITATION OF ABSTRACT UU	

THIS PAGE INTENTIONALLY LEFT BLANK

Approved for public release; distribution is unlimited

**ORGANIC OVER-THE-HORIZON TARGETING FOR THE 2025 SURFACE
FLEET**

Cohort 21/Team Alpha

LCDR Cale Johnson, USN	William Goh, Singapore
LCDR Brian Judy, USN	Yew Kee Hoo, Singapore
LCDR Nathaniel Spurr, USN	Dylan Zhiliang Lau, Singapore
LT Joseph Gullede, USN	Kwong Yang Lua, Singapore
LT Paul Harris, USN	Cheng Leong Ng, Singapore
LT Kyle Haubold, USN	Weiyu Phua, Singapore
LT Jason Riner, USN	Major Yang Siang Poh, Singapore

Submitted in partial fulfillment of the
requirements for the degree of

MASTER OF SCIENCE IN SYSTEMS ENGINEERING ANALYSIS

from the

**NAVAL POSTGRADUATE SCHOOL
June 2015**

Lead editor: Nathaniel C. Spurr

Reviewed by:

Timothy H. Chung
Project Advisor

Jeffrey E. Kline
OPNAV SEA Chair

Accepted by:

Clifford A. Whitcomb
Systems Engineering Department

Robert F. Dell
Operations Research Department

THIS PAGE INTENTIONALLY LEFT BLANK

ABSTRACT

Adversarial advances in the proliferation of anti-access/area-denial (A2/AD) techniques requires an innovative approach to the design of a maritime system of systems capable of detecting, classifying, and engaging targets in support of organic over-the-horizon (OTH) tactical offensive operations in the 2025–2030 timeframe. Using a systems engineering approach, this study considers manned and unmanned systems in an effort to develop an organic OTH targeting capability for U.S. Navy surface force structures of the future. Key attributes of this study include overall system requirements, limitations, operating area considerations, and issues of interoperability and compatibility.

Multiple alternative system architectures are considered and analyzed for feasibility. The candidate architectures include such systems as unmanned aerial vehicles (UAVs), as well as pre-positioned undersea and low-observable surface sensor and communication networks. These unmanned systems are expected to operate with high levels of autonomy and should be designed to provide or enhance surface warfare OTH targeting capabilities using emerging extended-range surface-to-surface weapons.

This report presents the progress and results of the SEA-21A capstone project with the recommendation that the U.S. Navy explore the use of modestly sized, network-centric UAVs to enhance the U.S. Navy’s ability to conduct surface-based OTH tactical offensive operations by 2025.

THIS PAGE INTENTIONALLY LEFT BLANK

TABLE OF CONTENTS

I.	INTRODUCTION.....	1
A.	PROJECT TEAM.....	2
B.	PROJECT BACKGROUND.....	5
C.	LITERATURE REVIEW AND TASKING EVOLUTION.....	7
D.	SYSTEMS ENGINEERING PROCESS MODEL	10
E.	ORGANIZATION OF REPORT	12
F.	REPORT CONTRIBUTIONS.....	13
II.	NEEDS ANALYSIS.....	15
A.	STAKEHOLDER ANALYSIS	15
1.	Stakeholder Identification.....	16
a.	<i>CRUSER – Monterey, CA.....</i>	<i>18</i>
b.	<i>NWDC – Norfolk, VA</i>	<i>18</i>
c.	<i>PACFLT – Pearl Harbor, HI</i>	<i>19</i>
d.	<i>OPNAV – Washington, DC</i>	<i>19</i>
2.	Stakeholder Interviews.....	21
III.	SCOPE	25
A.	SCOPE METHODOLOGY	25
B.	IN SCOPE.....	25
1.	Mission Needs Statement.....	27
2.	Anti-Access Area Denial (A2/AD)	28
3.	Surface-on Surface Engagement	30
4.	Organic Assets and Capabilities	31
5.	Interoperability and Compatibility	31
C.	OUT-OF-SCOPE	32
IV.	FUNCTIONAL ANALYSIS	35
A.	FUNCTIONAL DECOMPOSITION.....	36
1.	Top-Level Functions and their Descriptions	37
2.	Top-Level Functional Flow Block Diagram	45
V.	CONCEPT OF OPERATIONS AND PRELIMINARY DESIGN.....	47
A.	SEA-21A SCENARIO NARRATIVE	47
1.	Narrative Insights	49
2.	Tactical Situation	51
3.	Vignettes.....	53
4.	Area of Uncertainty Determination	54
5.	Present Day Scenario	56
B.	EMERGING REQUIREMENTS AND PRELIMINARY DESIGN...56	
1.	Requirements Analysis and MOEs, MOPs, and COIs	57
2.	Conceptual System Design	62
3.	Architecture Alternatives: Design and Selection	64
4.	Ethical Considerations.....	71

VI.	MODELING AND SIMULATION	73
A.	THE PROJECT TEAM’S APPROACH	73
B.	MODELING AND SIMULATION GOAL	74
C.	HIGH-LEVEL CONSTRAINTS, LIMITATIONS, AND ASSUMPTIONS	75
1.	Constraints	75
2.	Limitations	75
3.	Assumptions	76
D.	MODELING SOFTWARE OVERVIEW	78
1.	EADSIM	78
a.	<i>Modeling in EADSIM</i>	79
b.	<i>Dropping EADSIM from the Modeling and Simulation Effort</i>	82
2.	ExtendSim	83
a.	<i>Modeling the UAV Candidate Architecture in ExtendSim</i>	83
3.	Microsoft Excel	93
E.	REVISED BASELINE SCENARIO FOR EXCEL AND EXTENDSIM MODELING EFFORTS	96
1.	Revised Scenario	96
F.	SUMMARY OF MODELING AND SIMULATION EFFORTS	98
VII.	ANALYSIS OF ALTERNATIVES	101
A.	OBJECTIVE	101
B.	ALTERNATIVE ARCHITECTURES CONSIDERED	102
1.	Alternative 1 – UAV Architecture Description	102
2.	Alternative 2 – Pre-positioned Network Architecture Description	103
C.	ANALYSIS METHODOLOGY AND RESULTS	103
1.	Pairwise Comparisons	103
2.	Value Curves	107
a.	<i>Performance Value</i>	108
b.	<i>Adaptability Value</i>	111
c.	<i>Mobility Value</i>	112
d.	<i>Deployability Value</i>	112
3.	Value Scores and Decision Matrix	114
4.	Swing Weights	115
5.	Decision Matrix	115
VIII.	COST ESTIMATION	119
A.	COST ESTIMATION METHODOLOGY	119
1.	UAV Architectures Cost Estimation Method	120
2.	Pre-positioned Network Architecture Cost Estimation Method	122
a.	<i>NOAA’s DART Buoy</i>	122
b.	<i>U.S. Navy’s Seaweb</i>	123
c.	<i>Liquid Robotics’ Wave Glider</i>	124

B.	COST ESTIMATION ASSUMPTIONS.....	126
C.	UAV ARCHITECTURE COST ESTIMATION DATA ANALYSIS	127
1.	Procurement Costs and Cost Estimating Relationships.....	127
2.	UAV Architecture Life Cycle Cost Estimate.....	130
D.	PREPOSITIONED NETWORK ARCHITECTURE COST ESTIMATION DATA ANALYSIS	131
1.	Procurement Costs.....	131
2.	Research, Development, Test, and Evaluation Costs.....	133
3.	Operations and Support Costs.....	133
4.	Pre-positioned Network Life Cycle Cost Estimate	134
E.	CONCLUSION	135
IX.	SEA-21A RECOMMENDED DESIGN SOLUTION	137
A.	SURFACE FORCE COMPOSITION	137
B.	UAV SYSTEM	138
C.	FINAL FORCE STRUCTURE RECOMMENDATION.....	140
X.	RECOMMENDED FUTURE ANALYSIS.....	143
A.	SHIP-LAUNCHED UAV INTEGRATION CHALLENGES.....	143
B.	IMPROVING THE SPEED, RANGE, AND LOGISTICS OF SHIP-LAUNCHED UAVS.....	144
C.	ENGAGE WITH WARFARE DEVELOPMENT COMMANDS TO DEVELOP SURFACE-BASED OTHT CONOPS	145
D.	ASSESS THE IMPACT OF RECOMMENDED SOLUTIONS ON PHASE 0 OPERATIONS.....	145
E.	HYBRID UAV-PPN SYSTEM OF SYSTEMS ARCHITECTURE	146
F.	ANTICIPATE ADVERSARIAL TECHNOLOGY ADVANCEMENT.....	146
APPENDIX A.	SEA-21A TASKING LETTER.....	147
APPENDIX B.	EADSIM MODELING SPECIFICS	151
A.	MODELING IN EADSIM	151
1.	Entities within EADSIM.....	151
2.	Model Attributes	152
B.	BEHAVIORS.....	154
C.	EADSIM PROOF OF CONCEPT SCENARIOS	154
1.	2015 Proof of Concept Scenario.....	155
2.	2025 Proof of Concept Scenario.....	155
D.	EADSIM STUDY SCENARIOS.....	156
1.	2015 Baseline Scenarios.....	156
a.	<i>Scenario A1: 2015 Red vs. Blue with Air Support.....</i>	<i>156</i>
b.	<i>Scenario A2: 2015 Red vs. Blue without Air Support ...</i>	<i>159</i>
2.	2025 Future Scenarios	160
a.	<i>Scenario B1: 2025 Red vs. Blue with Organic OTHT Air Platform.....</i>	<i>160</i>

b.	<i>Scenario B2: 2025 Red vs. Blue with Underwater Sensor Network</i>	163
E.	PYTHON SCRIPTS FOR BATCH PROCESSING OF EADSIM OUTPUTS	164
APPENDIX C.	UAV TECHNOLOGY ANALYSIS	167
A.	CURRENT UAV PLATFORMS	167
1.	Boeing Insitu ScanEagle	167
2.	Boeing RQ-21A Blackjack	168
3.	Northrop Grumman MQ-8B Fire Scout.....	169
4.	Northrup Grumman MQ-8C Fire Scout	171
5.	Saab Skeldar V-200.....	172
6.	Schiebel Camcopter	173
7.	Northrop Grumman X-47B	174
B.	CURRENT UAV TECHNOLOGY STRENGTHS	175
1.	Autonomous Flight.....	175
2.	Sensor Capabilities.....	175
3.	Human and Crew Interoperability.....	176
4.	Security	176
C.	CURRENT WEAKNESSES	177
1.	Range.....	177
2.	Speed	177
3.	Logistics	178
4.	Integration	178
D.	CONCLUSION	179
	LIST OF REFERENCES	181
	INITIAL DISTRIBUTION LIST	187

LIST OF FIGURES

Figure 1.	Members of SEA-21A	3
Figure 2.	Waterfall Process Model (from Blanchard and Fabrycky 2010)	10
Figure 3.	SEA-21A Modified Waterfall Process Model	11
Figure 4.	Expanded Stakeholder Diagram	16
Figure 5.	Key Stakeholders and their Locations	17
Figure 6.	Refined Stakeholder Diagram.....	17
Figure 7.	Organic OTHT Surface-to-Surface Functional Decomposition	36
Figure 8.	OTHT Scenario Functional Flow Block Diagram	45
Figure 9.	South China Sea and Natuna Besar (from Google Maps 2015)	50
Figure 10.	Marine Traffic in the Vicinity of Natuna Besar (from Marine Traffic 2015)	55
Figure 11.	Modeling and Simulation Approach.....	73
Figure 12.	Relationship between Architecture, Performance and Time	74
Figure 13.	EADSIM Overview (from Teledyne Brown Engineering Inc. 2005).....	79
Figure 14.	EADSIM DTED0 Image of the South China Sea (from National Geospatial Intelligence Agency 2005).....	80
Figure 15.	EADSIM Proof of Concept Scenario Depiction.....	82
Figure 16.	Initial ExtendSim Single-UAV Model Block Diagram	86
Figure 17.	ExtendSim Single-UAV Model Equation Block	87
Figure 18.	Final ExtendSim Single-UAV Model Block Diagram	91
Figure 19:	Single UAV Final Model Results	93
Figure 20.	Example Microsoft Excel “What-If Analysis” Output	94
Figure 21.	Revised Baseline Scenario with Maritime Traffic Density (from Marine Traffic 2015)	98
Figure 22.	Graphical Depiction of KPP Comparison Weights	106
Figure 23.	Performance Value Curve.....	110
Figure 24.	Adaptability Value Curve	111
Figure 25.	Mobility Value Curve	112
Figure 26.	Deployability Value Curve	113
Figure 27.	Candidate Architecture Relative Effectiveness	117
Figure 28.	Breakdown of Representative UAV Systems’ Life Cycle Costs.....	121
Figure 29.	NOAA’s DART Buoy System (from NOAA 2015).....	123
Figure 30.	U.S. Navy’s Seaweb Undersea Network (from Truver 2006).....	124
Figure 31.	Liquid Robotics’ Wave Glider (from AUVAC 2011)	125
Figure 32.	Cost as a Function of a UAV’s Total Weight CER	128
Figure 33.	Speed as a Function of a UAV’s Total Weight.....	129
Figure 34.	LCCE as a Function of UAV Speed Regression Model	131
Figure 35.	Seaweb Gateway Buoy Maintenance (Honegger 2011)	132
Figure 36.	PPN LCCEs as a Function of Modems Required	134
Figure 37.	Comparative LCCE Breakdown for Candidate Architectures.....	136
Figure 38.	Candidate Architecture Cost-Effectiveness Plot.....	139

THIS PAGE INTENTIONALLY LEFT BLANK

LIST OF TABLES

Table 1.	SEA-21A Project Team Composition.....	4
Table 2.	NPS Cross-Campus Outreach Stakeholder Summary	21
Table 3.	Stakeholder Identification and Analysis Summary.....	22
Table 4.	OTHT Platform Critical Operational Issues	59
Table 5.	SEA-21A Conceptual Requirements, Objectives, and Thresholds.....	63
Table 6.	SEA-21A OTHT Individual Construct Weighting	70
Table 7.	Construct Category Comparison.....	71
Table 8.	Modeling and Simulation Constraints	75
Table 9.	Modeling and Simulation Limitations	76
Table 10.	Modeling and Simulation Assumptions.....	77
Table 11.	UAV Variants Input Parameters	92
Table 12.	UAV Model Input Parameter Values.....	92
Table 13.	Prepositioned Network Inputs for Excel Model	95
Table 14.	PPN Sensitivity Analysis (Number of Network Sensors Required).....	96
Table 15.	Revised Scenario Baseline Parameters	97
Table 16.	Example INCOSE Pairwise Comparison Matrix.....	105
Table 17.	Calculated KPP Comparison Weightings	106
Table 18.	Representative UAV System Configuration Selection	109
Table 19.	Raw Value Scores for PPN and UAV Candidate Architectures.....	114
Table 20.	Candidate Architectures' Variation in Range and Classification	114
Table 21.	Key Attribute Swing Weight Assignment	115
Table 22.	Summary of Key Attribute Swing Weights and Measure Weights	115
Table 23.	Candidate Architecture Decision Matrix	116
Table 24.	Existing DoD UAV Procurement Cost and Performance Data	127
Table 25.	UAV Procurement Cost as a Function of Speed and Weight	129
Table 26.	Total LCCE for Five Potential UAV Systems as a Function of Speed ...	130
Table 27.	Total LCCE for Three Potential PPN Systems	134
Table 28.	Summary of UAV Variants' Speed and Sensor Radius.....	138
Table 29.	Summary of UAV Configurations and Procurement Costs	139

THIS PAGE INTENTIONALLY LEFT BLANK

LIST OF ACRONYMS AND ABBREVIATIONS

A2/AD	Anti-Access/Area-Denial
AEW	Airborne Early Warning
AoA	Analysis of Alternatives
AOI	Area of Interest
AOR	Area of Responsibility
AOU	Area of Uncertainty
AO	Area of Operations
ASBM	Anti-Ship Ballistic Missile
ASCM	Anti-Ship Cruise Missile
ASEAN	Association of Southeast Asian Nations
ASUW	Anti-Surface Warfare
ASW	Anti-Submarine Warfare
AUVAC	Autonomous Undersea Vehicle Application Center
BDA	Battle Damage Assessment
BHA	Bomb Hit Assessment
C3I	Command, Control, Communications, Intelligence
C4I	Command, Control, Communications, Computers, and Intelligence
CAP	Combat Air Patrol
CER	Cost Estimation Relationship
CJCS	Chairman Joint Chiefs of Staff
CNO	Chief of Naval Operations
COI	Contact of Interest
COI	Critical Operational Issue
COIC	Critical Operational Issues and Criteria
COCOM	Combatant Command
COMPACFLT	Commander, United States Pacific Fleet
CONOPS	Concept of Operations
CRUSER	Consortium for Robotics and Unmanned Systems Education and Research
CSG	Carrier Strike Group
CVW	Carrier Air Wing
DARPA	Defense Advanced Research Projects Agency
DART	Deep Sea and Reporting Tsunami
DD	Destroyer
DDG	Guided Missile Destroyer
DF-21	Dong-Feng 21
DoD	Department of Defense

DOE	Design of Experiments
DSTA	Defence Science and Technology Agency (Singapore)
DTED	Digital Terrain Elevation Data
EADSIM	Extended Air Defense Simulation
EEZ	Exclusive Economic Zone
ELF	Extremely Low Frequency
EM	Electromagnetic
EO/IR	Electro-optical/Infrared
ESM	Electronic Support Measures
EW	Electronic Warfare
F2T2E	Find, Fix, Track, Target, Engage
F2T2EA	Find, Fix, Track, Target, Engage, Assess
FCO	Fire Control Officer
FFBD	Functional Flow Block Diagram
FF	Fast Frigate
GPS	Global Positioning System
HA/DR	Humanitarian Assistance and Disaster Relief
HF	High Frequency
ICBM	Intercontinental Ballistic Missile
IMINT	Image Intelligence
ISAR	Improved Synthetic Aperture Radar
ISR	Intelligence, Surveillance, and Reconnaissance
ISR&T	Intelligence, Surveillance, Reconnaissance, and Targeting
IOC	Initial Operational Capability
IR	Infrared
JASSM	Joint Air-to-Surface Standoff Missile
KPP	Key Performance Parameter
LDUUV	Large Diameter Unmanned Undersea Vehicle
LCCE	Life Cycle Cost Estimate
LCS	Littoral Combat Ship
LF	Low Frequency
LOS	Line of Sight
LRASM	Long Range Anti-Ship Missile
MADM	Multi-Attribute Decision Making
MALE	Medium Altitude Long Endurance
MANA	Map-Aware Non-uniform Automata
MILCON	Military Construction
MIO	Maritime Interdiction Operations
MOE	Measure of Effectiveness
MOOTW	Military Operations Other Than War

MOP	Measure of Performance
N9I	Warfare Integration
NEO	Non-combatant Evacuation Operations
NMS	National Military Strategy
NOAA	National Oceanic and Atmospheric Association
NPS	Naval Postgraduate School
NSMWDC	Naval Surface and Mine Warfare Development Command
NSS	National Security Strategy
NSS	Naval Simulation System
NWDC	Naval Warfare Development Command
O&S	Operations and Support
OPNAV	Chief of Naval Operations
OSD	Office of the Secretary of Defense
OTH	Over-The-Horizon
OTHT	Over-The-Horizon Targeting
PACFLT	U.S. Pacific Fleet
PACOM	Commander, U.S. Pacific Command
PCS	Position, Course, and Speed
P_d	Probability of Detection
P_{hit}	Probability of Hit
P_k	Probability of Kill
PLAN	People's Liberation Army Navy
PMEL	Pacific Marine Environmental Laboratory
PoL	Pattern of Life
POTUS	President of the United States
PPN	Prepositioned Network
PRC	People's Republic of China
QDR	Quadrennial Defense Review
RCS	Radar Cross-Section
RDT&E	Research, Development, Test and Evaluation
RF	Radio Frequency
RGM	Surface-to-Ground Missile
ROE	Rules of Engagement
RSAF	Republic of Singapore Air Force
SAF	Singapore Armed Forces
SAG	Surface Action Group
SAR	Synthetic Aperture Radar
SATCOM	Satellite Communications
SEA	Systems Engineering Analysis
SEA-21A	NPS Systems Engineering Analysis Cohort 21, Team A

SOSUS	Sound Surveillance System
SSGN	Nuclear Powered Guided Missile Submarine
ST	Singapore Technologies
STUAS	Small Tactical Unmanned Air System
TASM	Tomahawk Anti-Ship Missile
TDSI	Temasek Defense Systems Institute
TERN	Tactically Exploited Reconnaissance Node
TLAM	Tomahawk Land-Attack Missile
TST	Time-Sensitive Target
TTPs	Tactics, Techniques, and Procedures
UAV	Unmanned Aerial Vehicle
UHF	Ultra-High Frequency
USA	United States Army
USN	United States Navy
USNS	United States Naval Ship
USV	Unmanned Surface Vehicle
USW	Undersea Warfare
UUV	Unmanned Undersea Vehicle
VHF	Very High Frequency
VLS	Vertical Launch System

EXECUTIVE SUMMARY

According to Commander of Naval Surface Forces VADM Thomas Rowden, Commander of Naval Surface Force Atlantic RADM Peter Gumataotao, and Director of Surface Warfare (N96) RADM Peter Fanta, “The surface force is taking the offensive, to give the operational commander options to employ naval combat power in any anti-access/area-denial (A2/AD) environment” (Rowden, Gumataotao, and Fanta 2015). This objective of enhancing the ability of U.S. naval forces to control the seas underscores the importance of maintaining maritime dominance through a concept known as “distributed lethality,” realized by an independent offensive capability for surface ships. This is imperative in an A2/AD environment, which may present an unacceptable risk for employment of an aircraft carrier to provide over-the-horizon (OTH) targeting capability for U.S. Navy surface combatants.

The proposed tasking statement for the SEA-21A project team, as directed by OPNAV N9I (Deputy Director for Warfare Integration), began as a broad exploration of maritime intelligence, surveillance, and reconnaissance (ISR) in support of tactical offensive operations within a contested littoral environment. Through engagement and continuous interaction with stakeholders, the initial tasking statement was scoped down by the project team with the focus of enhancing the ability of surface ship and/or its parent surface action group (SAG) to organically find, fix, and kill an adversary surface target. This was captured by SEA-21A by the revised tasking statement:

Design a maritime intelligence, surveillance, reconnaissance, and targeting (ISR&T) system of systems (SoS) and concept of operations capable of detecting, classifying, and engaging targets in support of OTH tactical offensive operations in a contested littoral area in the 2025-2030 timeframe.

Consider the following:

- **manned and unmanned systems that reach initial operational capability (IOC) by 2020;**

- **requirements, limitations, operating area, bandwidth and connectivity, electromagnetic (EM) degradation, interoperability, compatibility, logistics, and forward deployment; and**
- **alternative architectures and their comparative effectiveness and costs.**

With focus shifted to a U.S. Navy surface combatant's organic capability to employ weapons OTH against a surface target, the SEA-21A project team considered numerous architectures with current or future potential to support the functions required to complete this kill chain. These architectures were then down-selected to those likely to meet requirements for technology development and logistics support in order to reach IOC by 2020. Left with the candidate architectures of unmanned aerial vehicles (UAVs) and prepositioned networks (PPNs), the project team utilized a tailored systems engineering process model that culminated in the modeling and simulation of the two architectures with a subsequent cost-effectiveness analysis. These efforts by SEA-21A lead to the following recommendation:

The U.S. Navy should develop an integrated network-centric surface-based UAV system capable of airspeeds in excess of 110 kts and sensor ranges of greater than 130 nm to enhance surface fleet organic OTH first-strike capabilities within A2/AD environments by 2025.

In order to facilitate further development of this capability for the U.S. Navy surface fleet, the following considerations are offered in accordance with the study's recommendation:

1. Address ship-launched UAV integration challenges. In addition to tasks related to the integration of hardware and software components, special attention must be paid to manpower and training support of ship-based UAVs, in addition to the technical and logistical challenges associated with launch and recovery of such a system at sea.
2. Pursue enabling technology for improving the speed and range of ship-based UAVs. As technology continues to improve, emphasis should be placed on the development of advanced materials for UAVs and support systems, improvements in energy storage and distribution, and miniaturization of onboard sensors and components.
3. Encourage fleet engagement and experimentation. Early involvement with the fleet is critical to accelerating the adoption and employment of UAV capabilities while soliciting fleet input to support capability enhancement.

4. Engage with Naval Warfare Development Command (NWDC) and Naval Surface and Mine Warfare Development Command (NSMWDC) to develop CONOPS for the organic employment of UAV systems by hunter-killer SAGs. Areas of focus should include integration with candidate long-range weapons, development of a comprehensive plan for operational employment and Phase 0 support, and exploitation of enhanced capabilities that will facilitate integration with emerging systems or technologies.

Additionally, SEA-21A identified potential areas for future study that will serve to enhance or refine its recommendations and considerations. These include but are not limited to:

1. Exploring additional modeling scenarios and architecture configurations. Potential scenarios include the consideration of littoral regions outside the South China Sea, with a broader investigation of the performance of other SoS configurations, such as a UAV/PPN hybrid architecture.
2. Assess the impact of recommended solutions on Phase 0 operations. Consider the merits of an advanced UAV-based ISR capability for day-to-day maritime surveillance and battlespace situational awareness.
3. Anticipate adversarial technology advancement. As U.S. military capabilities continue to improve, the timely assessment of emerging adversarial military technologies and capabilities will be critical if a first-strike capability is to be preserved.

As Admirals Rowden, Gumataotao, and Fanta stated, “If U.S. naval power is to reclaim maritime battlespace dominance in contemporary and future A2/AD environments, the surface Navy must counter rapidly evolving missile, air, submarine, and surface threats that will challenge our ability to sail where we want, when we want” (Rowden, Gumataotao, and Fanta 2015). Control of the seas in contested littoral environments is a significant challenge in A2/AD environments. This will likely preclude the use of the U.S. Navy’s carrier strike group (CSG) construct and its reliance on the embarked carrier air wing to provide an over-the-horizon targeting (OTHT) capability for U.S. Navy surface combatants. The emergence of a more tailored, network-centric, and geographically distributed formation of hunter-killer SAGs that possess an organic OTHT capability through a robust UAV system paired with a suitable long-range offensive weapon will permit a less centralized command and control (C2) structure, enhance overall flexibility, and represent the very core of the surface Navy’s concept of “distributed lethality.”

THIS PAGE INTENTIONALLY LEFT BLANK

ACKNOWLEDGMENTS

The students of Systems Engineering Analysis Cohort 21, Team A (SEA-21A) would like to sincerely thank our faculty advisor Dr. Timothy Chung, Assistant Professor of Systems Engineering, NPS, for his sage guidance and patience throughout the duration of our study.

SEA-21A would also like to thank the NPS Systems Engineering and Operations Research departments' faculties for their instruction and dedication to excellence in preparing us with the intellectual tools and body of knowledge necessary to complete such a demanding nine-month project.

While many stakeholders provided excellent information and guidance throughout our study, SEA-21A would specifically like to thank and acknowledge the following individuals for their contributions:

RADM (Ret.) Jerry Ellis, NPS
RDML (Ret.) Rick Williams, NPS
CAPT (Ret.) Wayne Hughes, NPS
CAPT (Ret.) Jeffrey Kline, NPS
CDR (Ret.) Matthew Boensel, NPS
LTC (Ret.) Mark Stevens, NPS
Dr. Diana Angelis, NPS
Dr. Michael Atkinson, NPS
Dr. Ronald Giachetti, NPS
Dr. Clifford Whitcomb, NPS

Finally, we would like to thank our families for their patience and understanding through the duration of not only this capstone project, but also the entire two-year course of study in this curriculum. Without their selfless support, our graduate educations and this capstone project would not have been possible.

THIS PAGE INTENTIONALLY LEFT BLANK

I. INTRODUCTION

Former Chief of Naval Operations (CNO) Admiral (Ret.) Vern Clark characterized the future vision for the United States Navy (USN) by unveiling *Sea Power 21* in 2002, which leveraged global defensive assurance and joint operational independence into projecting precise and persistent offensive power in what he termed “Sea Strike” (Clark 2002). A predominant concept in Sea Strike is the use of sea-based unmanned (and even autonomous) vehicles and sensors in the projection of naval power. At the heart of this concept and integrated with these foreshadowed unmanned sea-based assets is the mission-reconfigurable Littoral Combat Ship (LCS). With this remarkably clear vision for the Navy’s future use of unmanned technologies, *Sea Power 21* also envisioned “next-generation missiles capable of in-flight targeting, aircraft with stand-off precision weapons, extended-range naval gunfire, information operations, stealthy submarines, [and] unmanned combat vehicles.” However, in 2002, the Navy’s only long-range capable surface-to-surface missile, the Tomahawk anti-ship missile (TASM), had been shelved for nearly 10 years (LaGrone 2015).

Today, with the rise of numerous unmanned systems, long-range anti-ship missiles, electronic counter measures, and silent diesel submarines presenting challenging anti-access/area-denial (A2/AD) threats, the surface Navy’s ability to independently engage in long-range anti-surface warfare (ASUW) may be enhanced, particularly if using the existing CSG construct for long-range power projection and sea control carries high risk. Though defending a high-value, mission-essential unit, such as the aircraft carrier, remains a core of surface warfare doctrine, the surface warfare community has championed a new concept of “distributed lethality,” a concept for independent surface action groups (SAGs) to take the offensive and provide an operational commander the ability to fight for sea control in an A2/AD environment (Rowden, Gumataotao, and Fanta 2015).

Advances in enhancing surface ships’ ASUW capabilities are quickly being made. From exploring alternative methods of employing existing sea-based cruise missiles, such as the Tomahawk land attack missile (TLAM), to the development of a long-range anti-ship missile (LRASM), the U.S. Navy is exploring both short- and long-term solutions as

part of the Department of Defense's (DoD's) Third Offset Strategy (LaGrone 2015). Regardless of the potential platforms, weapons systems, and technologies currently being considered, the problem the U.S. Navy is really trying to solve is how it can enable its surface fleet to both see and engage maritime surface targets beyond the radar horizon, thereby countering the restrictions and/or limitations of operating in an A2/AD environment.

In September 2014, SEA-21A was tasked by the Chief of Naval Operations' (OPNAV) Deputy Director for Warfare Integration (N9IB) Mr. Mike Novak and the Naval Postgraduate School's (NPS) SEA Chair CAPT (Ret.) Jeffrey Kline to investigate the Navy's future capability to conduct over-the-horizon targeting (OTHT) in a maritime littoral environment in the 2025–2030 timeframe (Kline 2014). The official tasking statement, as it has now evolved, is as follows:

Design a maritime intelligence, surveillance, reconnaissance, and targeting (ISR&T) System of Systems (SoS) and concept of operations capable of detecting, classifying, and engaging targets in support of organic over-the-horizon (OTH) tactical offensive operations in a contested littoral area in the 2025–2030 timeframe.

Consider the following:

- **manned and unmanned systems that reach initial operational capability (IOC) by 2020;**
- **requirements, limitations, operating area, bandwidth and connectivity, electromagnetic (EM) degradation, interoperability, compatibility, logistics, and forward deployment; and**
- **alternative architectures and their comparative effectiveness and costs.**

A. PROJECT TEAM

The Systems Engineering Analysis Cohort 21, Team Alpha (SEA-21A) Capstone Project Team consists of 14 NPS students from both the United States and Singapore. The student team members of SEA-21A are depicted in (L-R): Yew Kee Hoo, Singapore; William Goh, Singapore; Dr. Timothy Chung, NPS; LT Kyle Haubold, USN; LT Paul Harris, USN; LT Jason Riner, USN; LCDR Nathaniel Spurr, USN; LCDR Cale Johnson, USN; LCDR Brian Judy, USN; LT Joseph

Gulledge, USN; Weiyou Phua, Singapore; Dylan Zhiliang Lau, Singapore; Kwong Yang Lua, Singapore; Cheng Leong Ng, Singapore; Major Yang Siang Poh, Republic of Singapore Air Force (RSAF)

Figure 1.



(L-R): Yew Kee Hoo, Singapore; William Goh, Singapore; Dr. Timothy Chung, NPS; LT Kyle Haubold, USN; LT Paul Harris, USN; LT Jason Riner, USN; LCDR Nathaniel Spurr, USN; LCDR Cale Johnson, USN; LCDR Brian Judy, USN; LT Joseph Gulledge, USN; Weiyou Phua, Singapore; Dylan Zhiliang Lau, Singapore; Kwong Yang Lua, Singapore; Cheng Leong Ng, Singapore; Major Yang Siang Poh, Republic of Singapore Air Force (RSAF)

Figure 1. Members of SEA-21A

The team members have professional backgrounds that span a wide range of fields, both inside and outside of the military. Specific naval warfare communities represented by the team's U.S. Navy students include naval aviation, surface warfare, and submarine warfare, with platform experience that spans FA-18s, E-2s, P-3s, H-60s, E-6Bs, aircraft carriers, frigates, and fast attack submarines. The Republic of Singapore is represented by one Singapore Armed Forces (SAF) major and six civilian exchange students participating in the Singapore Temasek Defense Systems Institute (TDSI) program. These international students boast backgrounds in technology and acquisition with working experience in the

Singaporean defense industry that spans modeling, simulation, design, and major program management. The project team and each member's respective background is shown in Table 1.

Table 1. SEA-21A Project Team Composition

<p><u>SEA-21A Capstone Project Advisor</u> Dr. Timothy Chung (NPS Assistant Professor, Systems Engineering)</p>
<p><u>SEA-21A Recommended Subject-Matter Experts</u> RADM (Ret.) Winford G. (Jerry) Ellis (NPS Chair of Undersea Warfare) RDML (Ret.) Rick Williams (NPS Chair of Mine and Expeditionary Warfare) CAPT Daniel Verhuel, USN (NPS Senior Intelligence Officer) CAPT (Ret.) Wayne Hughes (NPS Professor, Operations Research) CAPT (Ret.) Jeffrey Kline (NPS Professor of the Practice, Operations Research)</p>
<p><u>SEA-21A Capstone SEA Students</u> LCDR Cale Johnson (Aviation, P-3C Orion Naval Flight Officer) LCDR Brian Judy (Aviation, E-2C Hawkeye Pilot) LCDR Nathaniel Spurr (Aviation, FA-18E/F Super Hornet Pilot) LT Joseph Gullede (Surface Warfare Officer) LT Paul Harris (Aviation, P-3C Orion Naval Flight Officer) LT Kyle Haubold (Submarine Warfare Officer) LT Jason Riner (Aviation, P-3C Orion Pilot)</p>
<p><u>SEA-21A TDSI Students</u> William Goh (SAF Armored Vehicle C4I Systems) Yew Kee Hoo (SAF Facilities Policy and Process Management) Dylan Zhiliang Lau (Modeling and Simulation Development, DSTA) Kwong Yang Lua (Ship Design, ST Marine) Cheng Leong Ng (Proof of Concept & Experimentation, ST Dynamics) Weiyou Phua (Virtual Simulation & Interoperability, ST Electronics) Major Yang Siang Poh, RSAF (Management of UAV Systems)</p>

The project team first convened in September of 2014 and began cross-campus outreach to academics, military professionals, and industry experts in an effort to better understand key terminology and concepts suggested in the initial SEA-21A tasking statement. It was quickly realized that a number of capability gaps existed within the U.S. Navy and Marine Corps as it applied to conducting maritime intelligence, surveillance, and reconnaissance (ISR) and OTHT in a contested littoral environment, particularly when

facing an adversary capable of employing long-range A2/AD techniques. These discussion offered differing views of what the terms “littoral” and “A2/AD” really constituted, how the team would have to scope the all-encompassing ISR realm, and what potential adversary and threat systems would pose the greatest challenge to our ability to close these capability gaps. What transpired over the coming months would lead to a series of tasking statement and functional decomposition iterations as the project team took its first steps toward developing a maritime SoS design recommendation.

B. PROJECT BACKGROUND

With the rapid development of unmanned and autonomous technologies taking place in both the public and private sectors, the U.S. military has increasingly sought to utilize these technologies in order to enhance battlespace awareness in all domains: ground, air, surface, and undersea. Every branch of the U.S. military maintains and employs a variety of ISR assets in an effort to obtain (and in many cases, maintain) an offensive advantage over an adversary. This desired capability loosely equates to being able to shoot first (i.e., first-strike capability). While the ability to strike first has always been at the heart of nuclear warfare and a core focus of the U.S. during the Cold War, it has been almost completely lost as the emphasis of the U.S. Navy has been on projecting power ashore as its surface warriors’ mindset shifted from offensive to defensive (Rowden, Gumataotao, and Fanta 2015). The Navy’s modern-day surface combatants, such as *Arleigh Burke*-class DDGs and *Ticonderoga*-class CGs, became Tomahawk land-attack platforms and served as the aircraft carrier’s primary at-sea air defense, respectively. While both Aegis platforms also perform anti-submarine warfare (ASW) missions, the ability to engage other surface combatants beyond the radar horizon was limited to the engagement range of the eight RGM-84 Harpoon missiles contained within each ship’s dual Mk 141 missile launchers (IHS 2015a).

As the U.S. Navy’s surface fleet has enjoyed the increased standoff from shore provided by the BGM-109 TLAM, contention within many littoral environments has forced the current surface fleet from the sanctuary of the open ocean to more near-shore, restricted and often cluttered environments.

These littoral waters not only bring U.S. Navy surface combatants closer to an adversary's land-based ASCMs and anti-ship ballistic missiles (ASBMs), they also bring them closer to its surface fleet. Even if U.S. surface combatants can remain outside of these land-based engagement zones, an adversary can still deploy its fleet (both surface and undersea) to push the U.S. even farther away. This is the very definition of A2/AD and presents a very complicated problem for the U.S. Navy and its efforts to ensure stability while maintaining control of the seas, particularly those that possess globally significant sea lanes as in the case of the South China Sea.

A new emphasis on sea control derives from the simple truth that navies cannot persistently project power from water space they do not control. Nor can navies guarantee the free movement of goods in the face of a power-seeking adversary whose objective is to limit the freedom of the maritime commons within their sphere of influence. Sea control is the necessary precondition for virtually everything else the Navy does, and its provision can no longer be assumed. (Rowden, Gumataotao, and Fanta 2015)

Control of such contested littoral environments is challenging using today's modern CSG construct with the aircraft carrier and its embarked carrier air wing as its primary OTHT capability. What is likely to emerge is a more tailored, network-centric, and geographically distributed formation of ships that the surface warfare community's leadership is calling "hunter-killer surface action groups" (SAGs). Such surface combatant constructs would permit a less centralized command and control (C2) structure, enhance overall flexibility, and represent the very core of the surface Navy's new concept of "distributed lethality."

Distributed lethality is the condition gained by increasing the offensive power of individual components of the surface force (cruisers, destroyers, littoral combat ships, amphibious ships, and logistics ships) and then employing them in dispersed offensive formations known as "hunter-killer SAGs." It is the motive force behind offensive sea control. (Rowden, Gumataotao, and Fanta 2015)

In order for U.S. Navy surface combatants to both establish and maintain sea control in desired areas inside a contested littoral environment, the hunter-killer SAGs must possess a first-strike advantage over adversary warships – a weapon system and/or capability to both maintain battlespace awareness to the threat system and outmatch that

same threat system in employment range. Some of the potential “value-adds to the lethality mix” as suggested by the Commander of U.S. Naval Surface Forces include:

- offensive surface-to-surface missile utilizing a “bolt-on” launcher or fully integrating the weapon into the ship’s existing combat system;
- persistent organic airborne ISR and data relay capable of launch and recovery from the hunter-killer SAGS while also operating in a satellite-denied or jamming-intensive environment; and
- command and control (C2) equipped with detect-to-engage sensors and networked communications systems capable of passing critical friendly force, battlespace shipping, and combat forces information (Rowden, Gumataotao, and Fanta 2015).

As characterized above by the head of the U.S. Navy’s surface fleet, both an offensive surface-to-surface missile and a persistent organic ISR asset lie at the very heart of the distributed lethality concept. It is this capability gap that exists for the current U.S. Navy surface fleet when an adversary utilizes effective A2/AD techniques in holding an aircraft carrier and its air wing at risk in such littoral environments. Since many countries navies possess longer range surface-to-surface missile capabilities than the United States, it is clear that maintaining the ability to shoot first in an OTHT scenario is essential for the new hunter-killer SAG and distributed lethality concepts to succeed. It is this needed capability that SEA-21A seeks to address through this analysis by utilizing both current and emerging technologies, platforms, and weapon systems for the 2025-2030 timeframe of interest.

C. LITERATURE REVIEW AND TASKING EVOLUTION

In addition to the sources already referenced in this chapter, numerous other published works were reviewed in an effort to establish a solid academic foundation and understanding from which to dissect the initial problem statement and properly define the problem. The original tasking statement (see Appendix A) and its title, “Maritime ISR in the Contested Littorals,” initially led the SEA-21A team to focus heavily on the expansive ISR regime and how it can be both implemented and leveraged in the maritime domain to

support tactical offensive operations. The initial research revolved around current and future systems and technologies that will be available in the 2025–2030 timeframe, with scholarly journals, defense publications, and previous research and theses reviewed for applicability. In an effort to broaden the understanding of the entire team, each member was responsible for reviewing a minimum of five sources and providing a summary of each to the project team. Additionally, each team member provided a tailored brief to the project team that emphasized their own experiences in the military and/or defense industry and how particular platforms, capabilities, and technologies they had used provide additional insight to this study.

Regardless of the focus or mission area(s) addressed by studies such as this, nearly all U.S. defense programs can trace their foundations to the principles and guidance outlined in the President’s annual National Security Strategy (NSS). Particularly as it applies to this study, the 2015 NSS states “...we will grow our investment in crucial capabilities like cyber; space; and intelligence, surveillance, and reconnaissance” (White House 2015). ISR has proven critical to U.S. military operations over land and has become increasingly necessary in the maritime domain as advances in A2/AD techniques by potential adversaries restrict the once unchallenged operations of U.S. Navy combatants in international waters – particularly those in littoral environments, such as the South China Sea. This is specifically addressed in the current year’s NSS by the President:

The United States has an enduring interest in freedom of navigation and overflight, as well as the safety and sustainability of the air and maritime environments. We will therefore maintain the capability to ensure the free flow of commerce, to respond quickly to those in need, and to deter those who might contemplate aggression. On territorial disputes, particularly in Asia, we denounce coercion and assertive behaviors that threaten escalation. We encourage open channels of dialogue to resolve disputes peacefully in accordance with international law. We also support the early conclusion of an effective code of conduct for the South China Sea between China and the Association of Southeast Asian States (ASEAN). (White House 2015)

As an over-arching document, the President’s NSS has a direct influence on the National Military Strategy (NMS) presented by the Chairman of the Joint Chiefs of Staff (CJCS) to the Secretary of Defense. In the 2011 NMS proposed by then-CJCS Admiral

Michael Mullen, USN, ISR and its importance in current and future military (particularly joint) operations is specifically addressed:

In today's knowledge-based environment, the weight of operational efforts is increasingly prioritized not only by the assignment of forces, but also by the allocation of ISR capabilities. The ability to create precise, desirable effects with a smaller force and a lighter logistical footprint depends on a robust ISR architecture. (Mullen 2011)

The NSS and NMS provide guidance to ensure the security of our nation while simultaneously outlining current and future areas of focus for the U.S.'s civilian and military leadership. It is clear from these most recent strategies that ISR plays a pivotal role in not only ensuring the security of our homeland, but also of our soldiers, sailors, Marines, and airmen on battlefields around the globe in every domain. The ability for surface ships to access existing ISR architectures and conduct organic ISR operations at sea in an A2/AD environment is at the core of SEA-21A's problem definition. In the words of then-Secretary of Defense Chuck Hagel from the 2014 Quadrennial Defense Review (QDR):

Timely, accurate information about operational and tactical situations is essential to the effective accomplishment of any military mission. We will rebalance investments toward systems that are operationally responsive and effective in highly contested environments, while sustaining capabilities appropriate for more permissive environments in order to support global situational awareness, counterterrorism, and other operations. (Hagel 2014)

As previously discussed, the initial tasking statement provided by OPNAV N9I through the NPS Chair of Systems Engineering Analysis CAPT (Ret.) Jeffrey Kline specifically addresses the need for a maritime ISR SoS to *support* tactical offensive operations. Though it will be discussed in more detail in a Chapter II of this report, continuous engagement of key stakeholders by members of the SEA-21A project team resulted in a dramatic mindset shift near the halfway point of the nine-month project timeline. After engaging staff members of the Commander, U.S. Pacific Fleet (COMPACFLT) in Honolulu, HI, and interfacing with resident NPS stakeholders and OPNAV staff, it quickly became apparent that simply "supporting" tactical offensive operations was not enough – the outcome of the study should provide a candidate SoS that could complete an organic surface-to-surface kill chain in an A2/AD environment.

D. SYSTEMS ENGINEERING PROCESS MODEL

In the discipline of systems engineering, there is no definitive, all-encompassing, “one-size-fits-all” process model that can be applied to virtually any scenario or problem. However, nearly every SE process model possesses one key attribute – the use of iteration to continuously refine and improve candidate solutions. A critical element of this process is to remain unbiased while considering all potential avenues, options, and alternatives so as to prevent arriving at a premature solution. Regardless of the model chosen, the objective is to describe the process that will be tailored to a specific need (Blanchard and Fabrycky 2010). A well-known SE process model is the waterfall depicted in Figure 2. This model has its roots in software development and usually consists of five to seven phases.

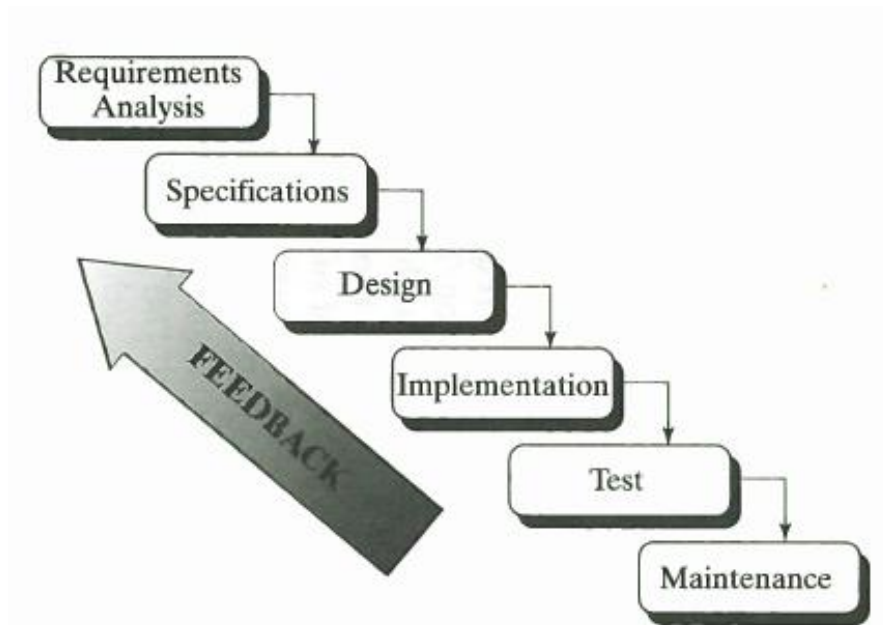

Figure 2. Waterfall Process Model (from Blanchard and Fabrycky 2010)

In order to help guide the study through the design process while also facilitating traceability as it unfolded, the SEA-21A project team elected to modify the traditional waterfall process model depicted in Figure 2 in order to ensure that all aspects of the team’s ultimate SoS design recommendation would be adequately addressed. This SEA-21A-specific modified waterfall process is shown in Figure 3.

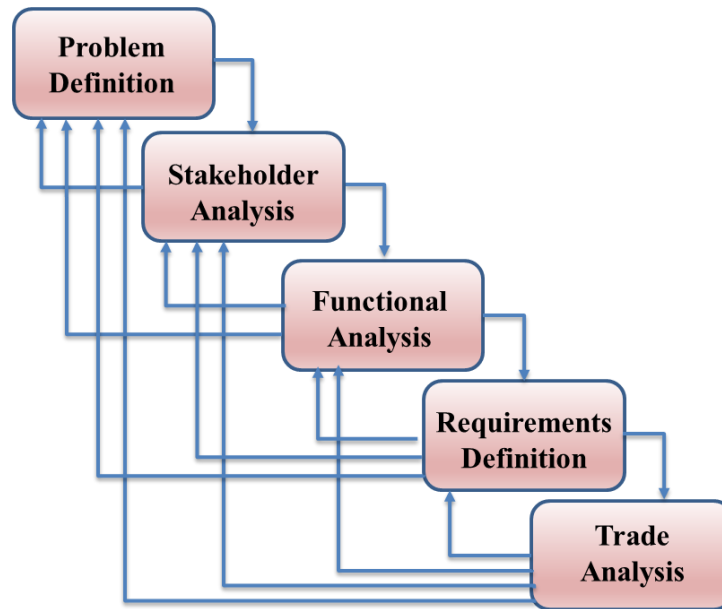

Figure 3. SEA-21A Modified Waterfall Process Model

As shown in Figure 3, the first step in SEA-21A’s SE process model is to define the problem. This is arguably one of the most important steps of an SE process model and considerable time was spent by SEA-21A in properly defining the problem. Each sentence in the initial tasking statement was broken down with an emphasis on properly defining key terms, such as “contested littoral area,” “tactical offensive operations,” and “challenging EM environment.” Different terminology can mean different things in different contexts, so it was critical to properly define such key terms at the study’s outset. Many of these terms were discussed with SEA-21A project stakeholders during the second step of the process model, “Stakeholder Analysis,” in conjunction with the project team’s cross-campus outreach. These discussions fostered an even greater understanding of the problem statement while providing feedback to the “Problem Definition” phase. As previously discussed, the SEA-21A project team’s tasking statement was revised a number of times before arriving at the final version. This evolution is described in detail in Chapter III.

The second step of the SE process model is “Stakeholder Analysis.” The SEA-21A project sought out subject-matter experts both on and off campus. This included various active duty military commands, industry professionals and government contractors, as well

as academics. While an all-encompassing list of stakeholders would take a considerable amount of time from the already compressed SEA-21 nine-month schedule, the key top-level stakeholders were identified and interviewed appropriately in order to determine a capability need statement that would provide traceability back to the problem definition.

With the analysis of stakeholders complete, the project team moved forward with a general “Functional Analysis.” This third step flowed together with the fourth step of the SEA-21A project team’s SE process model, “Requirements Definition.” By analyzing the functions that a potential SoS design solution would need to perform helped tease out requirements necessary to perform these functions. Just as with the first two steps of the process model, steps three and four allowed for multiple iterations of both.

Once the requirements of the SoS were determined, a “Trade Analysis” was conducted. This involved an in-depth modeling and simulation (M&S) effort, as well as a comparison of potential design solutions and competing architectures using an analysis of alternatives (AoA) coupled with cost estimation (CE) techniques. This would both quantify and justify the SEA-21A project team’s recommended design solution at the conclusion of the study.

While the SEA-21A project team’s SoS design recommendation is just that, a recommendation, it is also important to note that this project serves as an initial study for the U.S. Navy in the design and development of an organic maritime ISR SoS capable of conducting surface-to-surface OTHT operations – the acquisition process in addition to research, development, testing, and evaluation (RDT&E), production, operation and support (O&S), and disposal have not been considered. The findings and recommendations of this study will likely serve as an initial step in developing the necessary SoS to meet future needs at sea for a SAG to organically complete a long-range surface-to-surface OTHT kill chain.

E. ORGANIZATION OF REPORT

The organization of this project report closely mirrors the SEA-21A tailored SE waterfall process model depicted in Figure 3. With a thorough research effort and literature review document in Chapter I, the report flows to a needs analysis (Chapter II) and on to

the project's scope (Chapter III) and functional analysis (Chapter IV). It is in Chapters III and IV where the heart of the SE effort lies. These two chapters serve not only to properly scope the problem into something that permits a critical analysis for the 14-man project team, but they also help to define what the SoS must do in order to meet the needs of its stakeholders while striving to remain solution neutral. Together, the first four chapters drive the fifth – concept of operations. In this chapter specific scenarios and vignettes are developed in order to verify and validate the high-level functions and requirements determined in the previous two steps of the SE process model.

The “Trade Analysis” step of SEA-21A’s modified waterfall model encompasses Chapters VI through VIII. These chapters document M&S, AoA, and CE efforts to help quantify and characterize each of the potential SoS candidate architectures. From these analyses an ultimate SoS design solution (force structure) is recommended by the SEA-21A project team (Chapter IX). This chapter seeks to properly describe the SoS in detail the team feels meets both the requirements of the problem definition and capability needs statement outlined in Chapter III. As this study is only one analysis in addressing long-range organic surface-to-surface OTHT gap for the U.S. Navy, the report concludes with recommendations for future analysis (Chapter X). It is in this chapter that potential threads for additional study are discussed, leaving the door open for future avenues of analysis. Three appendices are also included for reference purposes that provide the official SEA-21A capstone project tasking letter, additional specifics for a portion of the project team’s modeling and simulation efforts, and a detailed description of existing UAVs considered in this study.

F. REPORT CONTRIBUTIONS

The advanced development of long-range surface-to-surface missiles and A2/AD techniques by potential U.S. adversaries has challenged the U.S. Navy surface fleet’s dominance at sea for the first time since the end of the Cold War (Rowden, Gumataotao, and Fanta 2015). In order for the U.S. Navy surface fleet to regain its offensive edge, it must look toward unmanned technologies and extended range surface-to-surface weapons. This will ensure that the fleet’s CGs, DDGs, and LCSs/Fast Frigates (FFs) will be able to

both penetrate and operate within contested littoral environments where A2/AD techniques and long-range threat weapon systems would have once kept them out.

The use of unmanned technologies in extending the lethal radius of manned combat assets has been a priority for the U.S. military and will continue to be for the foreseeable future. The U.S. Navy surface force's desire to add a robust independent SAG capability to our fleet, or an ability to distribute lethality across the force, has energized though for needed technologies, tactics, and training.

The purpose of SEA-21A's capstone project is, therefore, to provide the U.S. Navy with a recommended SoS solution that permits a surface ship's commanding officer the ability to organically target and engage a surface threat in an A2/AD environment well beyond his or her ship's radar horizon, particularly in an electromagnetically challenging situation where off-board sensors are limited. Doing so will greatly enhance the U.S. Navy surface fleet's survivability and contribute to establishing sea control in contested waters.

This study was performed at the unclassified level due to the SEA-21A's international composition. Though research beyond the unclassified level is certainly warranted for a study of this subject matter, this was outside the control of the project teams. Attempting to delve into the classified regime would have been at the expense of our international partners, with the overall study quality and its analysis suffering.

II. NEEDS ANALYSIS

A. STAKEHOLDER ANALYSIS

There are many definitions for the term “system.” One found in a commonly used dictionary serves as a solid foundation for its definition and how it relates to Systems Engineering. Simply put, a system is a group of devices or artificial objects or an organization forming a network especially for distributing something or serving a common purpose (Merriam-Webster 2015). For the context of this capstone project, the SEA-21A team has been tasked with developing a “system of systems” (SoS). A SoS is defined as “a set or arrangement of systems that results when independent and useful systems are integrated into a larger system that delivers unique capabilities” (DoD 2004).

When speaking to this particular definition of a system, it is important to note that the composition of a SoS is heavily dependent upon a complete analysis of stakeholders, which includes those that are both directly and indirectly impacted by it. It is also important to remember that as a SoS grows, each additional subsystem may itself possess and/or represent entirely new or different stakeholders. This growth inherently results in a much larger group of stakeholders once each subsystem is integrated into a single, functioning SoS.

As with any systems engineering project, stakeholders’ needs ultimately drove SEA-21A’s recommended design solution. By identifying, conversing with, and conducting a detailed analysis of individual stakeholders, the team was able to better identify their primitive needs as the systems engineering process (SEP) progressed. By keeping the project’s key stakeholders directly involved with the project through the use of SEA-21A liaisons, the project team gained invaluable insight and knowledge throughout the design process. This was especially important as the project team’s interpretation and revisions on the tasking statement ultimately resulted in a dramatic mindset shift from maritime ISR to surface-based OTHT at the halfway point of the project’s nine-month timeline.

1. Stakeholder Identification

Given the wide scope of the problem statement, particularly as it applies to organic OTHT, a large and wide-ranging selection of stakeholders was initially identified. This selection included large commands, such as OPNAV and COMPACFLT, and unit-level ships and warfighters at the tactical level. As the team conducted its preliminary discussions, however, we were able to scope-down the list to a group that would likely have the greatest impact on the project and benefit the most from its results. Analysis and discussions among the team concluded with the development of the following expanded stakeholder diagram along with each stakeholder's area of influence shown in Figure 4.

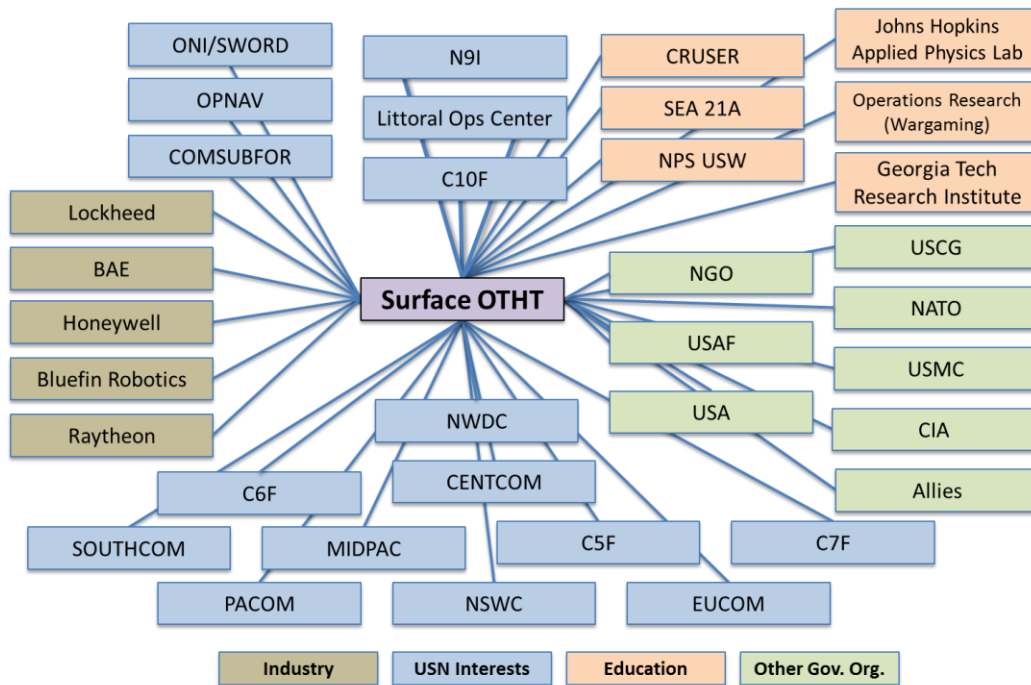

Figure 4. Expanded Stakeholder Diagram

As shown in Figure 4, the team initially identified a very large number of stakeholders. Realizing that many of these organizations and commands were only affected by second and third-order effects, the project team decided to narrow the field by selecting only the key, high-level stakeholders for continued analysis. Some of these key high-level stakeholders and their respective locations are depicted in Figure 5.



Figure 5. Key Stakeholders and their Locations

Each of these identified key stakeholders maintains a significant amount of interest and influence in the SEA-21A capstone project, and will ultimately benefit from its results and outcomes. These high-level stakeholders are depicted and appropriately linked to the SEA-21A project in Figure 6, and summarized in the paragraphs that follow.

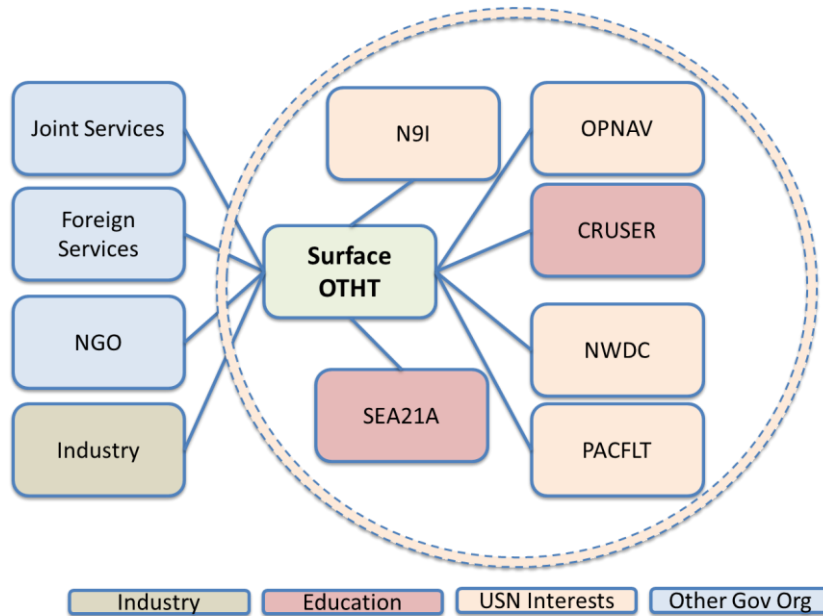

Figure 6. Refined Stakeholder Diagram

a. CRUSER – Monterey, CA

The Consortium for Robotics and Unmanned Systems Education and Research (CRUSER) is a consortium hosted at NPS that serves as a facilitator for the U.S. Navy as it pursues innovation in the realm of unmanned vehicles and emerging technologies (NPS CRUSER 2014). As a resource based on the collaboration between academic institutions, defense organizations and industry, CRUSER provides valuable insights and perspectives on current and future unmanned systems within the scope of SEA-21A’s project tasking through:

- collaborative research for industry and education;
- unmanned systems employment concepts for operations and technical research;
- evaluation of unmanned system employment concepts;
- providing opportunities for technology demonstrations;
- collecting user driven requirements for unmanned systems development;
- and
- encouraging the adoption of unmanned systems technology.

b. NWDC – Norfolk, VA

In 1998 the CNO established the Naval Warfare Development Command (NWDC). The NWDC is responsible for developing concepts, doctrine, lessons learned and experimentation in direct support of the Fleet (U.S. Navy 2015). As a primary stakeholder for the SEA-21A project, the inclusion/exclusion of current capabilities and developing technologies that will affect the future fighting capabilities of the fleet can be leveraged through NWDC’s ability to:

- develop doctrine to enhance maritime operational capabilities;
- identify loopholes in operational tactics and doctrine;
- understand the gap between current capabilities and adversaries’ capabilities;

- match weapons capabilities with detection capabilities (i.e., weapons’ striking range matching radars’ target locating range);
- develop technology that puts to use existing under-utilized capabilities; and
- identify trends and anticipating technologies that are “game changing.”

c. PACFLT – Pearl Harbor, HI

The U.S. Pacific Fleet’s Area of Responsibility (AOR) encompasses more surface area on the globe than any other U.S. Fleet and includes some of our most competent adversaries. The numerous potential littoral battlespaces associated with PACFLT’s AOR can be significantly complicated by an adversary’s ability to employ A2/AD techniques, which would, in turn, necessitate the use of OTHT tactics, techniques, and procedures (TTPs) in order to maintain an offensive advantage. In keeping with its prominence and impact on national security, PACFLT’s standing mantra has been: “Be a combat-ready Fleet, able to respond to any contingency when called (U.S. Pacific Fleet 2014),” and desires the following in a potential maritime SoS in order to remain at the tip of the warfighting spear:

- receipt of actionable, offensive OTHT ISR data;
- integrated tools and concepts for operational and tactical level planning;
- enhanced ISR collection and targeting capabilities;
- technological superiority and enhanced weapons standoff compared to adversary capabilities; and
- maintain an asymmetric warfare advantage.

d. OPNAV – Washington, DC

The Office of the Chief of Naval Operations is responsible to the CNO, who, in turn, is responsible to the Secretary of the Navy. The OPNAV staff offices are responsible for the command, utilization of resources, and operating efficiency of the operating forces within the Navy (Office of the Chief of Naval Operations 2014).

Within OPNAV, there are several office codes that are likely stakeholders in the SEA-21A capstone project. These offices include, but are not limited to N9I (NPS' SEA Program Sponsor), N81 (Assessments), and several N9X codes (Warfare Areas):

- N9I – SEA program sponsor and responsible for warfare integration amongst surface, air, and subsurface assets, to include both manned and unmanned alternatives;
- N81 – office responsible to the CNO for capabilities-based analysis of naval warfare and support requirements. OPNAV N81 has the ability to further examine the effectiveness of SEA-21A's recommended SoS by projecting its success in achieving a combination of offensive (control of the battlespace), defensive (reduction in the number of adversary attacks and blue force attrition), and operational objectives in core war fighting capability areas (Office of the Chief of Naval Operations N81, 2012); and
- N9X – several offices within N9 are included in this analysis are considered to be major stakeholders. Each office is responsible for the integration of plans and policies across all platforms (to include manned and unmanned) (Dawn Breaker Phase III Portal 2013):
 - N95 – responsible for the implementation of naval expeditionary warfare missions and programs, including amphibious warfare, mine warfare, naval special warfare, expeditionary warfare to include Explosive Ordnance Disposal (EOD), maritime expeditionary security force/naval coastal warfare, maritime civil affairs, expeditionary training and riverine warfare, and non-lethal weapons. N95 is also tasked with outlining the major characteristics and force structure of all amphibious and mine warfare ships and expeditionary warfare units;
 - N96 – responsible for surface warfare and the implementation of shipboard and related support requirements, as well as the major characteristics of programs involving surface combatants and command ships;
 - N97 – responsible for submarine warfare and the implementation of shipboard and related support requirements and major characteristics of programs involving submarines, deep submergence systems, and undersea surveillance systems; and
 - N98 – responsible for air warfare and the implementation of naval aviation and strike programs.

2. Stakeholder Interviews

The SEA-21A project team initially utilized resident NPS faculty members in order to further refine the initial tasking statement while also soliciting these individuals for external points of contact for further research. Faculty members included retired senior military officers and civilian academics who are actively involved in the defense industry and represent many of the stakeholders identified in Figure 6. A list of engaged NPS faculty members is summarized in Table 2.

Table 2. NPS Cross-Campus Outreach Stakeholder Summary

NPS Staff Member	Background
RADM Jerry Ellis, USN (Ret.)	NPS Chair of Undersea Warfare
RDML Rick Williams, USN (Ret.)	NPS Chair of Expeditionary & Mine Warfare
CAPT Jeffrey Hyink, USN	Senior NPS Aviator
CAPT Daniel Verheul, USN	Senior NPS Intelligence Officer
CAPT Jeffrey Kline, USN (Ret.)	Operations Research Department
COL. Jeff Appleget, USA (Ret.)	Operation Research Department, Wargaming
CDR Matt Boensel, USN (Ret.)	SE Department, Naval Systems Analysis
Dr. Doug Horner	Unmanned Maritime Systems
Dr. Cynthia Irvine	Chair of the NPS Cyber Academic Group
Dr. Kevin Jones	Unmanned Aerial Systems
Dr. Daphne Kapolka	Underwater Acoustic Propagation
Dr. Kevin Smith	Wave Glider Unmanned Surface Vehicles (USVs)
Dr. Phil Pace	Electronic Warfare
Dr. Chris Twomey	Chinese Foreign and Military Policy
Mr. Sean Kragelund	USVs, Underwater Garage

As a result of these cross-campus outreach discussions, it became apparent that the project team needed to properly define and scope the terms “littorals” and “ISR” due to the breadth that each of them can individually encompass. Additionally, this outreach allowed the team to more clearly refine and define the project’s stakeholders. These results are summarized in Table 3.

Table 3. Stakeholder Identification and Analysis Summary

Stakeholder	Position	Goals	Importance	Risk	Notes
Operational Commands	User	-Employ a system to effectively combat the assessed threat	High	-Dysfunctional System -Investing time and money into a system that cannot evolve with a changing threat -Having a system that is unable to function in an A2/AD environment	-While there are a myriad of COCOMs (Combatant Commands) and operational level commands, for the purposes of this report, the Pacific AOR will be the area of interest, hence PACFLT will be the Main Stakeholder.
Education Institutions	Support	-Utilize funding to educate, experiment, and test different aspects of manned and unmanned systems, which will help advance government and private sectors	High	-Progress is not cutting edge enough to stay relevant -Lack of program sponsors, thus funding could be pulled	-Many institutions were/are viewed as stakeholders. While many include different Applied Physics Labs, Technical Institutes, and other schools for the advancement in some kind of theory, a key stakeholder for the SEA-21A project is CRUSER. CRUSER has the luxury of not only being a program that helps the advancement of different studies (mostly within the unmanned realm), it also has the backing of the Secretary of Defense.
NWDC	Support	-Develop doctrine to employ a system or SoS that will perform Maritime ISR in a Littoral Environment	High	-Not developing a sound doctrine to fully utilize the developed system or SoS	-NWDC will disseminate doctrine to the fleet that it deems suitable for operations in an A2/AD environment
N9I	Support	-Develop and field a system or SoS that can conduct Maritime ISR Operations in a Contested Littoral Environment	High	-Not capturing the importance of A2/AD operations and getting the ideas out to the fleet	-As the program sponsor for the SEA curriculum, N9I has a vested interest in the system engineering analysis and future development of war fighting systems.
OPNAV	User	-Integrate plans and policies for integration into the fleet to carry out operations in support of COCOMs and National Interest	High	-Fielding a system that is not able to integrate into existing infrastructure	-Integration across all the N codes within OPNAV is very important to the success in the operation of the developed system or SoS.
NGO	User	-Be the recipient of information collected for use in conjunction with the NGO's mission	Low	-While not specifically owning any part of the developed system, the techniques advanced from this study will be available, but affordability may not be possible	-NGO's involved in employing such a system would be interested in information collection Humanitarian Operations...
Industry	Support	-Produce and profit from the engineering, integration, and development of the system or SoS	Low	-The risk exists that the costs associated with the development of new systems and the costs associated with the integration of current systems would not be beneficial to the bottom line of the company	-Industries involved in system development will be able to aide in the cross development of future systems to ensure operational success in an A2/AD environment
Foreign Services		-Be the recipient of information that could possibly lead to operations within the joint realm	Low	-Not having compatible systems needed to ensure safe operations to own country assets in an A2/AD environment.	-If compatibility issues do arise, history has shown that unfettered operations with the US has ensured safe operations of foreign assets in hostile environments
Joint Services		-In a joint environment, the information gleaned from the employment of an integrated system could produce actionable intelligence that will lead to successful joint operations	Medium	-Not having systems that are able to be integrated into the developed architecture	-Even though the developed architecture may not be compatible, the intelligence received may be slightly slowed, but still actionable on a larger scale.

The project team agreed that any systems or technologies considered for use in the ultimate SEA-21A design recommendation would need to reach IOC by 2020. This will allow for a five-year operational evaluation or “maturation period” for these emerging systems and technologies prior to the 2025–2030 timeframe of interest.

In addition to the NPS cross-campus outreach, SEA-21A sent a contingent to Hawaii to speak specifically with representatives of COMPACFLT, Commander, Naval Surface Group Middle Pacific (MIDPAC), and Commander, Submarine Force U.S. Pacific Fleet (SUBPAC) staffs. During these interactions it became apparent that a need exists for the U.S. Navy to advance its surface warfare-centric OTHT capabilities in order to preserve a first-strike maritime capacity independent of the CSG. Utilizing smaller, less costly assets to search, detect, target, and ultimately strike maritime surface targets beyond the radar horizon without exposing an aircraft carrier to high risk the primary concern at nearly every stakeholder level.

THIS PAGE INTENTIONALLY LEFT BLANK

III. SCOPE

A. SCOPE METHODOLOGY

This study's purpose is to develop a maritime SoS where a single U.S. Navy surface combatant can conduct OTHT on its own without dependency on other surface ships or national assets for targeting data. As the original tasking statement from N9I addressed the use of ISR, a term that itself encompasses nearly everything we do in target development, it was necessary to define what system characteristics we decided to include in our study (i.e., within scope) and those that we decided to exclude (i.e., out of scope). As the SEP is itself an iterative process, the scoping of the project by the team was performed in the same manner. While an initial scoping was conducted alongside the stakeholder analysis described in Chapter II, a more detailed scoping occurred as the project progressed and the initial tasking statement evolved.

Overall, the SEA-21A project team believes the scoping of this project has been performed in such a way that the recommended SoS design is grounded in reality and not imagination or conjecture. The project team focused on technologies and concepts that the DoD has either backed with substantial funding or established as official programs of record. With that said, much of what was included in the project's scope are weapon systems, platforms, sensors, and technologies (both U.S. and adversary) currently in use or in later stages of development in order to reach an IOC deadline of 2020 and ensure that they are fully operational by the 2025–2030 timeframe of interest.

B. IN SCOPE

SEA-21A's project scoping initially began by refining the initial tasking statement. The tasking statement for this project was provided by CAPT Jeffrey Kline, USN (Ret.), OPNAV Chair of Systems Engineering Analysis (SEA), in a memorandum to the SEA-21A cohort dated 07 August 2014 (see Appendix A). The initial statement, approved by the SEA program sponsor, OPNAV N9I, reads as follows:

Design a fleet SoS and concept of operations for employment of a cost effective and resilient maritime ISR system capable of collecting, fusing, and disseminating critical environmental and threat information in a contested littoral area in the 2025–2030 timeframe. Consider manned and unmanned systems in all domains to provide sufficient information to support effective tactical offensive operations. Consider employment requirements, operating areas, bandwidth and connectivity, interoperability, sensor data processing, transfer and accessibility, logistics, and basing support in forward areas or from CONUS bases. Generate system requirements for platforms, sensors, and communications in a challenging EM environment. Evaluate swarm concepts for inclusion in your solution. Then develop alternative architectures for platforms, sensors, manning, command and control, intelligence collection/dissemination and consumption, communication and network connectivity, and operational procedures. Address the costs and effectiveness of your alternatives. (Kline 2014)

Over the course of the first few weeks of the project, SEA-21A brainstormed and discussed potential scenarios and architectures to help meet the needs outlined in this initial tasking statement. What ultimately evolved was a more refined (scoped) tasking statement that was presented to Mr. Mike Novak of N9I and CAPT Jeffrey Kline, USN (Ret.), on 18 November 2014:

Design a maritime ISR fleet SoS and concept of operations capable of collecting, processing, exploiting, and disseminating critical environmental and threat information in support of tactical offensive operations in a contested littoral area in the 2025–2030 timeframe.

Consider the following:

- **manned and unmanned systems with an IOC by 2020;**
- **requirements, limitations, operating area, bandwidth and connectivity, EM degradation, interoperability, logistics, and forward deployment; and**
- **alternative architectures and their comparative effectiveness and costs.**

This revised tasking statement seemed appropriate for the project as the team continued to progress with functional decomposition, scenario and vignette development and functional flow block diagrams (FFBDs). However, through continued iteration and recursion, particularly with the team’s stakeholder analysis, it became evident that a large-

scale maritime design solution as suggested by both tasking statements did not, in fact, meet the identified high-level stakeholders' needs. While this will be detailed in the sections that follow, continued stakeholder engagement in addition to the revisions and final interpretation of SEA-21A's tasking statement resulted in a significant shift in the team's direction halfway through the study.

1. Mission Needs Statement

The development of an effective mission needs statement helps to properly identify the problem and quantify a capability shortfall that must be corrected in order to solve the identified problem. This capability shortfall is the defining basis of the ultimate design recommendation made by the project team. From the detailed stakeholder analysis documented in the previous section, it was evident to the SEA-21A project team that a need exists for the U.S. Navy surface warfare community to advance its capability in organically prosecuting surface targets that exist beyond the radar horizon. From the refined tasking statement and the analysis conducted in Chapter II, the SEA-21A project's mission need statement was defined by the team as follows:

A need exists to deploy an integrated system of manned and unmanned vehicles that can rapidly perform organic OTH detection and targeting of surface contacts in an A2/AD environment.

With the project's mission needs statement properly defined, the initial tasking statement was again revisited for continuity. This process, iterative in nature, permits additional stakeholder input and analysis throughout its duration. Since the mission needs and tasking statements go hand-in-hand, they reinforce the fact that both the problem and effective needs of the stakeholders have been properly identified.

The SEA-21A project team then utilized this mission needs statement and additional stakeholder interviews to scope and bound the original tasking statement into a more coherent and attainable objective. In the project team meetings that later transpired, it was determined that what was required by the key stakeholders was a more organic OTH capability for individual surface combatants, such as DDGs, CGs, and LCSs/FFs.

With the realization of this more specific mission need, the final “scoped” tasking statement was determined by the SEA-21A project team to be:

Design a maritime ISR&T SoS and concept of operations capable of detecting, classifying, and engaging targets in support of OTH tactical offensive operations in a contested littoral area in the 2025–2030 timeframe.

Consider the following:

- **manned and unmanned systems that reach IOC by 2020;**
- **requirements, limitations, operating area, bandwidth and connectivity, EM degradation, interoperability, compatibility, logistics, and forward deployment; and**
- **alternative architectures and their comparative effectiveness and costs.**

With the tasking statement finalized, the project team then began to investigate specific terminology and domains in order to better characterize what is considered to be in scope and out of scope for the project.

2. Anti-Access Area Denial (A2/AD)

A2/AD may be construed to mean many different things, from denial of movement through the means of jamming navigational sources or communications, to restricting movement in an area altogether. As Dr. Milan Vego of the U.S. Naval War College in Newport, RI states: “The success of any major operation or campaign depends on the free movement of one’s forces in the theater. Without the ability to conduct large-scale movements on land, at sea, and in the air, operational warfare is essentially an empty concept” (Vego 2009).

With this in mind and such threat ASBMs as the Chinese Dong-Feng 21D (DF-21) that boasts engagement ranges beyond 1500 nm (Global Security 2014) potentially denying U.S. surface combatants access to littoral areas, such as the South China Sea, the project team decided that this alone would cause military leadership to constrain the use of aircraft carriers in a such an area. This, by Dr. Vego’s very definition, is in fact A2/AD as we see it today. Current and future naval operations and surface force composition depend heavily on the ability of CSGs and SAGs to transit and conduct maritime operations in accordance

with international law. However, once a crisis situation or military conflict has developed, intentionally exposing an aircraft carrier to a high-risk situation without the potential for very high reward is to be minimized. Therefore, the use and/or dependency on the capabilities of an aircraft carrier and its embarked air wing would likely be restricted by an adversary's effective employment of A2/AD techniques. While a multitude of these techniques, such as the jamming of communications and precision navigation and timing (PNT) networks (e.g., the global positioning system (GPS)), as well as restricting freedom of the seas through the use of mines or submarines are available to potential U.S. adversaries today, the SEA-21A project team decided that A2/AD, as it applies to this study, is defined as the adversary's threat to an aircraft carrier and its embarked air wing in the projection of power in a littoral environment.

Though the use of communications jamming and spoofing is highly likely in A2/AD environments of the present and the future, for the purposes of this study we neglect their effects on satellite communications (SATCOM). Without a reasonable expectation of consistent satellite communications for the SEA-21A OTHT SoS design recommendation, the project team would have had to postulate some other radio frequency (RF) network/system would need to be developed in order to ensure uninterrupted communications between U.S. Navy surface combatants and the OTHT platform(s). Additionally, discussions with the program sponsor and operational stakeholders led the SEA-21A project team to conclude that the use of SATCOM would be unfettered. Therefore, for the purposes of the likely A2/AD environment considered in this study, the project team concluded that communications jamming and spoofing would not impact or restrict the use of SATCOM by its proposed SoS. Removing this assumption is an area for follow-on and classified research.

Just as there are many ways to define A2/AD, there are an equal number (if not more) ways to define the adjective "littoral." A commonly used dictionary defines the term as "...relating to, or situated or growing on or near a shore" (Merriam-Webster 2015). This definition, however, is simply too broad-based and general for use in this study. For the purposes of this project, the SEA-21A team has chosen to define littoral as any maritime environment where sea-based weapons can be employed against land targets. This

definition has been chosen because it characterizes a littoral environment as one in which maritime combatants possess the capability to project power ashore, whether within sight of the shoreline or OTH, and there is a high likelihood that “clutter” (non-combatant, neutral surface vessels) will present a problem in correctly classifying contacts that will ultimately impact the amount of time required to employ weapons. The term “littoral,” therefore, expands as our sea-based land-attack weapons capabilities expand. No longer are we referring only to confined waters and maritime choke points when we use the term littoral; neglecting submarine-launched intercontinental ballistic missiles (ICBMs), we can now classify any region as littoral if it possess a parcel of land that is targetable from the sea.

3. Surface-on Surface Engagement

The project team also decided to scope the domain of operations to surface-on-surface engagements. The primary reason for doing this is because traditional surface combatant vs. surface combatant engagement, something foreign to the last 30 years of U.S. sea combat, is anticipated to become more likely due to the effectiveness of current A2/AD techniques in keeping surface combatants displaced farther from shore. While the U.S. Navy still maintains the ability to prosecute *land* targets at these increased standoff ranges (i.e., OTH) using such ballistic guided missiles (BGMs) as the BGM-109 Tomahawk in conjunction with target cueing from other national assets, the need exists for U.S. Navy surface combatants to possess the capability of organically targeting and engaging a *surface* target beyond its own radar horizon. As current land- and surface-based Chinese threat systems possess superior first-strike capabilities compared to that of U.S. maritime surface assets (Walker 2013), the SEA-21A project’s SoS must provide a naval surface combatant the ability to dynamically target maritime surface targets in a littoral environment using the five tenets of dynamically targeting time-sensitive targets (TSTs): find, fix, track, target, engage, and assess (F2T2EA) (Joint Chiefs of Staff, 2007).

4. Organic Assets and Capabilities

In attempting to define the term “organic” the project team stepped back to analyze the ways in which the U.S. Navy currently operates since the term “organic” can be used at both the macro (strategic) and micro (tactical) levels. The project team agreed that “organic,” for the purposes of this project, is defined as TTPs capable of being executed by an individual ship, as well as those assets physically attached to and maintained by it when forward deployed.

For example, the carrier air wing (CVW) is an organic asset to the aircraft carrier and the CSG. If a surface combatant is part of the CSG, it would be able to leverage the OTH capability of the CVW in the prosecution of surface targets. However, the size, composition, and employment of CSGs and SAGs in the future are uncertain and could be influenced by emerging threat capabilities. Therefore, it makes tactical sense to assume that the ability to organically target OTH at the individual surface combatant level has a considerable impact on any CSG’s, SAG’s, or single ship’s survivability. In the case of an isolated surface combatant, such as a DDG, its ability to survive could very well be based solely upon its ability to organically conduct OTH and engage surface threats—likely by extending its ability to see beyond its own radar horizon, which, for example, is dictated by its mast height.

It was through this analysis of the term “organic” and how it applies to both platform capabilities and assets that the project team resolved to analyze the problem at the lowest level (a single ship) where the capability to perform OTH ISR, as well as OTH is not only essential for ensuring the survivability of the platform itself, but in establishing and maintaining an offensive advantage against surface-based threats.

5. Interoperability and Compatibility

Through the SEA-21A project team’s discussion of the importance of interoperability and compatibility and how it applies to units that may be organized into a group, systems and units that are resident within a designated group (such as a CSG or SAG) are considered to be organic to one another. “Interoperability” refers to the ability

for different systems, which are not subsystems of the same physical system, to work with each other in the accomplishment of a certain task or mission. The project team's discussion of the possible use of a submarine in a non-A2/AD environment emphasized that the challenge of ensuring that the SEA-21A proposed SoS allows for the potential interoperability with a submarine in order to prosecute a contact beyond an individual units existing maximum range.

Similarly, compatibility addresses the degree to which two or more components within a system function without mutual interference. This relationship is applicable to many facets of SEA-21A project. For example, if a SAG was deployed to perform over the horizon ISR in support of theater operations, the SAG can be considered an organic SoS, and when operating together, must be capable of doing so without mutual interference during the prosecution of a contact.

C. OUT-OF-SCOPE

While it would effectively negate the necessity of an organic OTHT capability for surface combatants, the use of weapons of mass destruction (both nuclear and chemical) has been universally accepted as out of scope due to the overarching political, ethical, and environmental implications associated with their use. Additionally, as has already been addressed, weapons systems, platforms, sensors, and technologies that will likely not demonstrate IOC by the year 2020 will also be considered out of scope. The SEA-21A project team desires a recommended design solution that is grounded in reality and makes the most cost effective use of existing large-scale weapon systems and platforms. The goal of this project is not to design a new weapon system or technology from the ground-up, but to incorporate both new and existing capabilities into a SoS design that meets the needs of the stakeholders in the 2025–2030 timeframe.

As was alluded to in Section B, the SEA-21A project team elected to focus specifically on surface-on-surface engagement. This, therefore, scopes out the subsurface domain and the monumental communications challenges associated with it, along with the use of the aircraft carrier and its air wing. With the aircraft carrier denied the unfettered dominance of an adversary's littoral areas due to A2/AD techniques, the ability for

extended use of the CVW is limited due to the enroute big-wing (i.e., non-organic) aerial refueling tracks that would be required to get carrier-based aircraft to/from potential maritime target areas. While the capability to conduct OTHT currently exists for the CSG and other tethered surface combatants through the use of the CVW, the restricted operating areas imposed on the aircraft carrier as a result of an adversary's A2/AD capabilities prohibits its full and effective use, and therefore, pushes it out of scope for the SEA-21A project.

Since the project team has chosen to focus exclusively on surface-to-surface engagement, the exclusion of undersea warfare (USW) and the use of submarines in the recommended design solution does not come without protest. While a submarine is most effective when it is operating below the surface, it is most vulnerable when operating at or near the surface—where it traditionally needs to be in order to effectively communicate with surface and aerial assets due to the difficulties associated with non-acoustic wave propagation through water. Though a submarine can already “see” further than it can effectively shoot with respect to the undersea realm, utilizing it as a primary OTH ISR system would only lead to a higher probability of it being detected by an adversary. While other submersible platforms and technologies, such as the large diameter unmanned undersea vehicle (LDUUV), offer promising capabilities in the undersea environment, they lack the speed and near real-time network communications necessary to be considered a viable system for conducting surface-based OTHT. Therefore, the incorporation of submersible assets has been considered out of scope for the SEA-21A project.

Though not as encompassing as the use of carrier-based air power and submarine warfare, the project team has decided to scope out the logistics piece of the SEA-21A SoS. Despite specifically detailing the logistical aspects and primary requirements of the logistical support structure required by the SEA-21A project team's design recommendation, the team did consider operating and support costs in the AoA and cost estimation portions of the project—both of which are detailed in their own chapters of this report. Although integral to the implementation of the ultimate design recommendation and essential for its maintenance and supply structure, the project team decided that to properly analyze and describe the logistical support structure necessary to support the SEA-

21A project design recommendation would require an effort of the same magnitude as the project itself. Therefore, it is highly recommended that further analysis and investigation be conducted in order to properly characterized and structure the logistics support architecture for this proposed SoS.

Additional avenues of the SEA-21A project that the team characterized as out of scope included the specific use of U.S. Army, Marine Corps, and Air Force platforms and personnel, as well as autonomous target prosecution and/or weapons release (i.e., “lethal autonomy”). While there are great technological strides being made in system autonomy, the project team felt that the ethical considerations and public opinion regarding its use would make it unrealistic to consider for the purposes of this project. This view was also reinforced by an SEA-21A project team member’s attendance at the 24 February 2015 National Defense University’s symposium on “Unmanned Systems Autonomy in the DoD” at Ft. McNair in Washington, D.C. The collective opinion of the expert panels invited to speak at the symposium was that autonomous lethality was many, many years in the future, and that DoD customers (i.e., the U.S. armed forces) desire additional levels of automation vice explicit autonomy.

As for the use of joint services, the SEA-21A project team concluded that since this is a U.S. Navy sponsored study with an emphasis on organic surface combatant OTHT, incorporating assets and capabilities of other armed services (both U.S. and international) would challenge the inherent need for the design recommendation to be organic. While it may be likely that intelligence gathered by national assets, such as satellites and aerial reconnaissance platforms, may aid in defining an initial area of uncertainty (AOU) for an individual surface combatant in the prosecution of an OTH target, exogenous assets will not be part of SEA-21A SoS design recommendation to address the specific need for organic offensive tactical capabilities.

IV. FUNCTIONAL ANALYSIS

The systems engineering process is one of iteration and innovation at each step. After defining the problem and its scope, the systems engineer must carefully consider the functions of the potential solution. This system or SoS will be defined and refined by its functions, and the functional analysis process. At each turn as the system becomes more refined and more mature, the ultimate design solution will begin to form as functions are then turned into requirements and evaluated for validation and verification. First, however, a function must be defined. A term that is so widely used can mean many different things to different people. The online Software and Systems Engineering Vocabulary (SEVOCAB) dictionary defines a function as “a task, action, or activity that must be accomplished to achieve a desired outcome, or a defined objective or characteristic action of a system or component (SEVOCAB 2015). This means that each function can act as a separate task or activity, or work in conjunction with other functions, to accomplish the common goal of the overall system. Understanding each function and how the design team arrived at each step is an important part of this process.

Functions are not simply born of random thought and integrated into the systems engineering process. They are first and foremost products of an iterative process termed functional analysis. Functional analysis is:

...an iterative process of translating system requirements into detailed design criteria and the subsequent identification of the resources required for system operation and support. It includes breaking requirements at the system level down to the subsystem and as far down the hierarchical structure as necessary to identify input design criteria and/or constraints for the various elements of the system. The purpose is to develop the top-level system architecture, which deals with both “requirements” and “structure.” (Blanchard and Fabrycky 2010)

Functional analysis should be performed early on in the systems engineering process, not necessarily to guarantee a form that the solution should take, but to guarantee that the problem is properly bounded by the correct functions and that those functions will lead to requirements that will ultimately drive a problem solution. This process provides

the baseline from which all other systems engineering activities can begin, as well as aiding in the integration of the ultimate SoS architecture.

A. FUNCTIONAL DECOMPOSITION

By performing a general functional analysis as depicted in Figure 7, the project team identified the key functionality required of a design solution as described in the refined SEA-21A tasking statement.

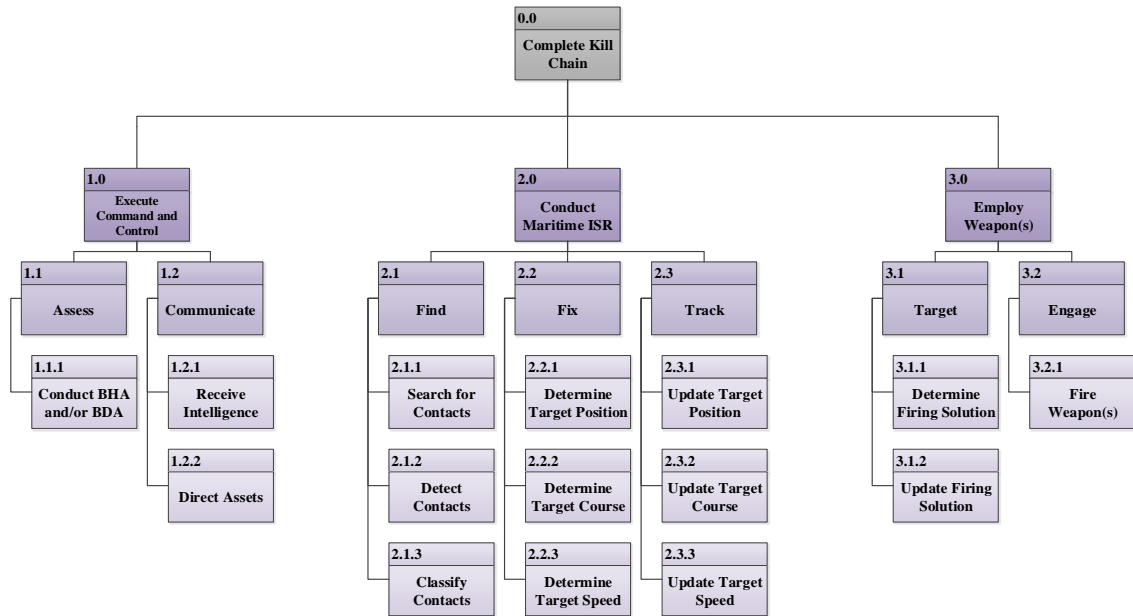

Figure 7. Organic OTH Surface-to-Surface Functional Decomposition

In a complex A2/AD environment, the ability of a ship’s commanding officer to organically gather the information necessary to employ his or her platform and weapon systems beyond the ship’s radar horizon, and the ability to make real-time engagement decisions based upon that information is a complex capability that is challenging for today’s surface Navy. If this commanding officer was able to use sensors and deployable assets organic to their own ship to generate and provide real-time OTH surface contact targeting data, he or she could preemptively employ weapons and properly defend their ship without the delay normally associated with gaining off-board national sensor information. These sensors organic to the platform should be evolved enough to provide

reliable, independent data, and data that is considered to be trusted as accurate at all levels of the chain of command. Additionally, this SoS should be linked so as to provide communication and/or data to any assets requesting it with the proper credentials.

The overall goal of the project team's maritime systems of systems is to complete the complex kill chain necessary to allow an individual commanding officer the ability to find, fix, track, target, and engage (F2T2E) a surface threat if necessary. This is accomplished through three primary high-level functions:

- 1.0 Execute Command and Control;
- 2.0 Conduct Maritime ISR; and
- 3.0 Employ Weapons.

These functions facilitate the integration of a collection of individual systems into a functional SoS for a U.S. naval surface combatant to F2T2E a surface threat. Execution of command and control is made possible by the availability of current and accurate information in each possible scenario, with employment of weapons as the designed SoS' end state. The scope of the project, however, combined with current U.S. Navy maritime littoral strategy, dictates that the main focus of this analysis be placed on the 2.0 Conduct Maritime ISR function.

1. Top-Level Functions and their Descriptions

1.0 Execute Command and Control

Command and control (C2) is always critical and is the crux of all military operations. This includes military operations other than war (MOOTW), humanitarian and disaster relief missions (HA/DR), and non-combatant extraction operations (NEO). Within the battlespace, however, C2 is critical to effective operations in order to assure that timely access to information leads to the correct target engagement at the correct time and at the correct distance. Across SEA-21A's maritime SoS and in support of the top-level function 0.0 Complete The Kill Chain and in scenarios where large or complex forces will be involved, a timely, efficient, and reliable method of issuing orders and direction will likely dictate success or failure of the mission. The SoS shall provide the commander a means of

executing C2 by assessing the operating environment for contacts of interest (COIs), or other contacts that meet certain tracking and/or targeting criteria. It shall also communicate all detections within its directed search area back to its organic platform for appropriate follow-on actions if required.

1.1 Assess: With a variety of potential air and maritime assets and sensors integrated into the project's recommended SoS, the battlespace environment must be continuously and reliably monitored in order to provide decision makers (i.e., ships' commanding officers) with important environmental data that may affect the ability of the SoS to collect and ultimately process data. This constant assessment of the battlespace will ensure that the SoS will yield accurate and up-to-date information on any COIs within a defined area. It will accomplish this through a variety of individual asset/sensor capabilities that, when combined, will present an accurate depiction (and likely forecast) of the conditions both above and below the surface of the water.

1.1.1 Conduct BHA and/or BDA: In order to better understand how well we are effectively employing our SoS and the weapons organic to the netted platforms, bomb hit assessment (BHA) and/or battle damage assessment (BDA) must be performed. This critical information repeated back to the decision maker will ensure the most up-to-date and accurate information on weapons effectiveness and what possible corrections or follow-on engagements (if any) should be made to ensure follow-on success.

1.2 Communicate: The primary vehicle for feeding information back to the decision maker will be the communication suite available to our SoS. In an A2/AD environment, the ability to execute two-way communications is a critical requirement of the project's SoS. Not only must the system have the ability to communicate through a variety of bands, such as high frequency (HF), low frequency (LF), extremely low frequency (ELF), ultra-high frequency (UHF), UHF

SATCOM, and very high frequency (VHF), but it also must be able to transmit the data and frequency hop as required to ensure the rapid relay and security of the data and information gathered.

1.2.1 Receive Intelligence: This maritime SoS shall have the ability to link itself to the national intelligence community and be capable of receiving regular reports and updates as required. It shall also be able to filter through the large number of intelligence reports and tailor its sensor(s) to the particular needs and ISR goals in the area of interest (AOI).

1.2.2 Direct Assets: Once intelligence has been received and processed, the SoS will have the ability to monitor the battlespace by directing its employable assets to the desired AOI(s). Once on station, the assets can begin communicating with the C2 structure and relaying what they see in real-time. Both before and after hostilities have commenced, the maritime SoS shall provide consistent direction of all movements, contacts, targets, engagements, BDA, and other factors within the battlespace that decision makers will need in order to maintain situational awareness in the battlespace. The SoS along with appropriate decision makers will allocate those sensors as necessary to particular AOUs or regions where intelligence reports specifically indicate a contact(s) of interest. Additionally, this maritime SoS shall provide decision makers the ability to assign and account for all sensor assignments across multiple assets and platforms in order to provide the highest possible situational awareness within the battlespace.

2.0 Conduct Maritime ISR

In order to properly conduct the maritime ISR function, the project team's proposed SoS will need to be able to collect and process information that it detects in its surrounding environment. The recommended design will accomplish this task through its

sub-functions of finding, fixing, and tracking COIs. In order to access the intelligence required to perform this task accurately, COIs will first need located (either organically or cued to an AOU from intelligence sources) to ensure commanders have the most up to date battlespace information available.

2.1 Find: One of the primary functions in conducting ISR is the collection of the information and data necessary for decision makers to appropriately employ both lethal and non-lethal assets against perceived threats. The project team's proposed SoS shall be capable of collecting that data and making it available to every node of its architecture in order to search, detect, and classify contacts as necessary. The system will do this within the battlespace through radar, infrared (IR), or other available signatures.

2.1.1 Search for Contacts: There are certain primary functions each data ISR collection system must perform. In order to collect data and sanitize the battlespace, assets must be capable of conducting effective area searches. These searches for contacts must be able to be conducted in virtually all weather conditions while achieving the desired scan rates required of decision makers for battlespace situational awareness. Every sensor should be networked to the maximum extent practicable into a database of previously recorded COIs and their associate radar, acoustic, and infrared signatures of the platforms specified and cued in by intelligence reports to better assist with the search.

2.1.2 Detect Contacts: Once an asset's search has commenced, actual contacts must be detectable using onboard sensors with an acceptable false alarm rate. These sensors must utilize every piece of cueing information available from its organic platforms in order to meet or exceed the desired probability of detection against COIs, whether on the surface, below the surface, or airborne. Detection windows shall be cued by the controlling

platform and relayed to its network of organic sensors in order to optimize the search and detection profile.

2.1.3 Classify Contacts: The recommended SoS shall classify all COIs utilizing all available collection assets and sensors. Specific contact information (e.g., number, speed, direction of travel, altitude/depth, and classification) obtained by the available sensors shall be documented and stored for future reference and/or processing. Organic assets and national databases (if available) shall be queried as required for additional correlation and contact fidelity as necessary. The ultimate resulting classification of each contact shall be reported immediately for further queuing if required, so as to allow for dwell time adjustments ahead of a possible targeting scenario and subsequent engagement. Lastly, the classification shall include the standard friendly, hostile, or unknown designations and be populated within appropriate communication(s) network for all members' awareness.

2.2 Fix: SEA-21A's SoS shall process the classified contacts in a prioritized manner, based upon the threat level each presents. This threat level can be either pre-determined based on commander's guidance or conducted ad-hoc as the picture develops. Once each contact is classified, a refined three-dimensional location can be accomplished utilizing GPS or laser designation in order to localize the position of the contact relative to the observing sensor platform. This data is communicated real-time to decision makers in order to facilitate a firing solution should an engagement become necessary. "Fix," as it used in the context of this project, will include the determination of a contact's position, course, and speed, as well as any additional characterizing information that could be gleaned from image intelligence (IMINT) or signals intelligence (SIGINT) sensors.

2.2.1 Determine Target Position: The recommended SoS shall have the ability to fix a target's position relative to the Earth's surface, as well as other organic assets and platforms. Target position shall be an all-weather capability of this SoS, with multiple systems likely required to determine a target's position in either an A2/AD or degraded weather environment.

2.2.2 Determine Target Course: In order to process and ultimately disseminate all applicable information, the sensor assets of SEA-21A's recommended SoS shall be capable of determining a target's current and projected course based upon relative motion, GPS, or laser designation. This information shall be passed back to the C2 platform to allow decision makers to determine which target(s) exhibit profiles associated with hostile intent.

2.2.3 Determine Target Speed: Along with geolocating a target's position and determining its current and projected course, the SoS shall be capable of determining a target's speed in order to allow for further analysis of a target's profile and possible engagement.

2.3 Track: The production of a target track and the function of tracking a target is critical to further target development and the generation of an accurate firing solution if required. Maintaining as accurate picture of all priority target tracks will provide decision makers with the best possible assessment of the battlespace while allowing for prioritization of targets, as well as the dropping or continued monitoring of targets based on commander's guidance.

2.3.1 Update Target Position: For a reliable track to be produced, the SoS shall be capable of generating the target position at given intervals. These fixed or flexible interval reporting windows will allow for individual commanders to not only pick which weapon to use for an engagement, but

also to custom tailor the delivery window to the target based on updates from its track. These data products will likely be in the form of short data packets, detailed pattern-of-life (PoL) histories, or GPS-quality targeting data/coordinates that are encoded and shared via secure channels for analysis and ultimate use to support the top-level function 0.0 Complete the Kill Chain.

2.3.2 Update Target Course: Sensor assets organic to the recommended SoS design shall possess the ability to update both a target's course and position after each new sweep or scan. This will ensure that the most accurate target location information is available for the determination of a firing solution if required.

2.3.3 Update Target Speed: Similarly, the sensor assets organic to the recommended SoS shall update a target's speed. This parameter is a key factor in determining a weapon's intercept profile and in identifying potential limiting lines of approach for a target's engagement.

3.0 Employ Weapons

In order to organically conduct maritime OTH surface-to-surface engagements, our SoS must provide a ship's commanding officer with the ability to engage a target beyond the ship's radar horizon. Additionally, the project team's recommended SoS should possess the capability not only to track these targets, but to determine, build, and update their firing solutions prior to and after weapons launch.

3.1 Target: As COIs meet or exceed thresholds set by standing rules of engagement (ROE) or commander's guidance, they will then become targets and preparations for weapons engagement will begin. Targets shall have all available sensors assigned to it in order to ensure the most accurate and up-to-date firing solution is obtained prior to engagement. This process will also require the project team's

recommended design solution to logically develop this firing solution and continually update it up to and after weapons release.

3.1.1 Determine Firing Solution: SEA-21A's SoS shall be capable of determining a firing solution on multiple designated targets and provide recommendations to fire control officers (FCOs) and decision makers on which weapon to employ. The firing solution for each target will be maintained and updated in internal memory as long as the system maintains active contact with the target.

3.1.2 Update Firing Solution: The firing solution shall be updated continuously while the system holds active contact with the target. The update rate for this firing solution will be higher leading up to weapons release or when the threat is in close proximity to the launch platform.

3.2 Engage: Finally, the recommended SoS will possess the capability to offensively engage targets once a valid firing solution has been obtained. The SoS will be capable of recommending to the FCO the optimum weapon for employment based on the targets range, speed, and course. The decision to engage a target will not be automated for offensive employment, but may be utilized in close-in engagements where human reaction time and task saturation may prevent the timely prosecution of inbound threats posing a risk to the launch platform.

3.2.1 Fire Weapons: With the decision to engage a target made, the recommended SoS shall be capable of firing a weapon to engage the designated target. As previously mentioned, the selection of the weapon to be fired will be recommended to the FCO and decision makers based upon target characteristics (e.g., range, course, speed, altitude/depth), but ultimate selection of the weapon be left to the human in the loop. Once the weapon is enroute to the target, update guidance will be provided as

required by either on-board or off-board cuing sources in order to enhance the weapon's probability of hit (P_{hit}).

2. Top-Level Functional Flow Block Diagram

With the high-level functions of the project's systems of systems properly identified, potential scenarios can be developed in order to put these functions to use in the employment of the system. These scenarios can be represented graphically through the use of FFBDs. By definition, FFBDs depict "top level functions...broken down into second-level functions...into third-level and so on, down to the level necessary to adequately describe the system and its various elements in functional terms... (Blanchard and Fabrycky 2010)." Simply put, these diagrams allow for a better visualization of how each system function pairs with and complements other functions in the accomplishment of a certain scenario or vignette. For instance, the ability for a U.S. Navy surface combatant to execute OTHT is of critical importance to this study. Though the engagement scenario depicted by the FFBD in Figure 8 is general and unrefined, it serves to validate the functional decomposition previously presented in Figure 7.

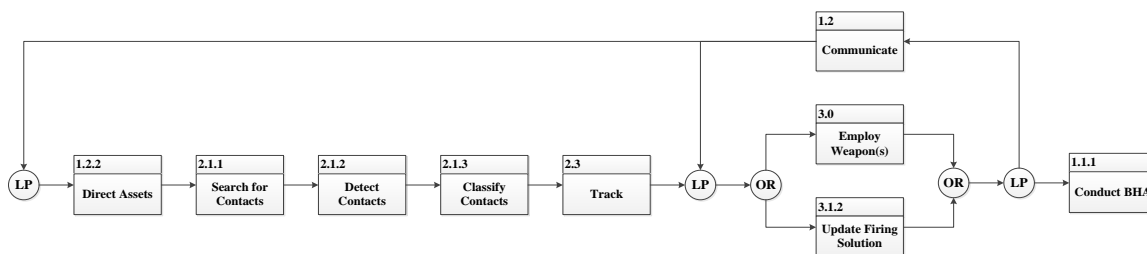

Figure 8. OTHT Scenario Functional Flow Block Diagram

Once intelligence regarding the presence of a threat is received, whether from an organic sensor or a national asset inject, the SoS can be employed to search, detect, and ultimately classify contacts as required. Targeting can then commence with a decision to engage or update target coordinates as required. If the target is engaged through the employment of a weapon, the loop is exited and BHA and/or BDA is conducted after the weapon has impacted the target. On the other hand, if the target is not engaged, the loop is

repeated again with the decision to either engage or update target coordinates. This process can be repeated as many times as desired for continuous target tracking or until the target is engaged with a weapon.

V. CONCEPT OF OPERATIONS AND PRELIMINARY DESIGN

When designing a complex system, it can be easy to lose focus on the problem being solved as smaller scale problems emerge and are subsequently analyzed. This “tunnel vision” creates the potential for time consuming, expensive mistakes to be made. In an effort to chase down solutions to the smaller problems, a key capability need could be missed or a threshold level of performance not reached. Describing the problem the engineer intends to solve in story-form can help keep the systems engineering team, stakeholders, and sponsors informed as to what is actually happening and focused on the ‘big picture’ problem.

Much effort has been put into defining the scenario for a potential OTHT SoS. This analysis aims to capture the basic details of any story: who, what, when, where, why, and how. The scenario must also capture key players involved and operational objectives. One purpose of performing such a scenario analysis is to define the mission of the system being designed (Blanchard and Fabrycky 2010). It must identify the primary mission, and any others that are to be considered relevant to the problem. Once the general scenario is generated, it is varied in order to capture all possible situations that could significantly impact the employment and performance of the system. They also aim to highlight critical decision points and who must make these decisions. These variations or “what-ifs” are referred to as vignettes and several have been captured with respect to the proposed surface-to-surface OTHT system.

As the SEA-21A project team has struggled with the problem at hand, so too has the team struggled with developing the correct story to characterize it and its associated functions. With each iteration of the problem statement, the scenario has been updated to satisfy new needs.

A. SEA-21A SCENARIO NARRATIVE

The backstory selected for this narrative is based largely upon a scenario presented by CAPT (Ret.) Jeffrey Kline in a previous NPS course in Monterey, CA taken by the SEA-21 cohort from July to September 2014, titled OA4602 *Joint Campaign Analysis*.

While much of the narrative remains unchanged since it was presented to the cohort in July 2014, many details have been adapted in order to describe how a long-range surface-on-surface engagement may develop with a formidable naval adversary, such as the PLAN of the People's Republic of China (PRC), in a contested littoral environment like the South China Sea:

Beginning in the spring of 2025, a Vietnamese fishing vessel is rammed and sunk by a Chinese maritime security ship. The Chinese government justifies the unfortunate action as an enthusiastic ship's captain defending China's exclusive economic zone (EEZ) rights, although similar incidents have occurred over the past 20 years. Vietnam does not accept China's rationale and vows that their fishing fleet, as well as their at-sea drilling rigs, will henceforth be protected. Two weeks later a Chinese deep-sea exploration ship unexpectedly explodes approximately 100 nautical miles north of the Indonesian island of Natuna Besar in the South China Sea. The Chinese government insists that Vietnam, Indonesia or the Philippines are responsible for its loss and they mobilize their South China Sea fleet and demand restoration from all three countries or China will 'secure' their sea.

One month later the PLAN sinks a patrolling Vietnamese ship using a land-based surface-to-surface missile launched from Woody Island (YJ-83) in the Paracels. They subsequently announce that all traffic through the South China Sea will henceforth be subject to inspection and control by Chinese forces. The Chinese then move to invade and occupy Natuna Besar in order to assert control of the South China Sea's southern approaches and in compensation for the alleged 'attack' on their deep-sea exploration ship. In addition to the amphibious forces China positions on Natuna Besar, they also deploy a DF-21 missile battery in order to expand their engagement range of interfering surface combatants. A PLAN contingent of smaller surface combatants and mine-layers arrives behind the amphibious invasion forces and begins active patrols around Natuna Besar to assist in restricting access to the South China and its associated shipping lanes while also erected a blockade around the island in order to prevent other navies from interfering with their efforts.

Indonesia, Vietnam, and the Philippines quickly request United Nations (U.N.) support, specifically calling on the U.S. and Japan to act. In response, China warns Japan and the United States that any interference with their enforcement policy will lead to war, with the threat of nuclear escalation. To show their resolve, China mobilizes their East Sea and South Sea fleets and sails at least 50 submarines from both fleets, including two nuclear powered guided missile submarines (SSGNs) on what are assessed to be strategic deterrence patrols. They have also declared a quarantine on all military logistics support (including oil) to the Japanese island of Okinawa

and have set up ships in blocking positions around it to conduct maritime interdiction operations (MIO).

The President of the United States (POTUS) is currently unwilling to allow China the ability to restrict freedom of the seas and to deny regional sovereign nations control of their territorial waters. POTUS decides to challenge the blockade of the South China Sea, however he prefers to challenge the blockade without the use of a CSG for two reasons—first, he does not want to create an escalatory reaction from China; second, and most importantly, he is unwilling to place an aircraft carrier at risk within the range of a DF-21 missile. To this end, two U.S. Navy SAGs possessing OTHT capabilities to engage both maritime and land targets rapidly mobilized and deployed to the SEVENTH FLEET AOR and await further direction.

1. Narrative Insights

The first problem the project team’s scenario aims to resolve is defining when and where the system will operate. From the problem statement and narrative it is clear that the system will operate between 2025 and 2030. This timeline assists in defining what technologies are available for consideration. It also helps determine the potential force compositions and structures of both sides. Any surface combatants that either nation will produce prior to 2030 should, therefore, be considered. Additionally, the scenario places the conflict in a specific littoral region of the world, the South China Sea. Given the recent contention in eastern Asia regarding small archipelagos, such as the Spratly and Senkaku islands, a setting like the South China Sea and its southern littoral choke point Natuna Besar as depicted in Figure 9 is appropriate.



Figure 9. South China Sea and Natuna Besar (from Google Maps 2015)

Chinese forces are using Natuna Besar as a base of operations and a location from which they can assert additional influence in the region. Due to the high levels of shipping traffic that transits to and from the Strait of Malacca through Natuna Besar's surrounding waters, it is likely that PLAN surface combatants will be operating south of the island where the waters between Borneo and Malaysia are not as wide (geographic choke point), resulting in a smaller overall area to monitor. However, it is likely the American forces will approach from the north, having already been deployed to the South China Sea from the west coast of the United States or Yokosuka, Japan.

Clearly, the main players involved in this scenario are China and the United States and that, for the purposes of this analysis, only these two nations will be considered as military participants. While it is likely that other regional nations, such as the Philippines, Indonesia, Japan, and Vietnam, would likely participate to some extent in a conflict like this, thereby adding increased credibility to the intervention by the U.S., the focus of this study is to establish an OTHH surface-on-surface engagement capability for U.S. Navy surface combatants. As a result, only the interactions between American and Chinese ships are considered.

2. Tactical Situation

The scenario narrative is only a piece of the overall story being told. To examine exactly where a surface combatant-based OTHT system fits into the story, its concept of operations (CONOPS) must be described. A CONOPS helps inform the project team by providing specifics of how the system will be employed and problems it will likely encounter. As previously described, the tactical situation begins after the President has ordered the deployment of two U.S. Navy SAGs. Since the execution of USW has been considered out of scope for this analysis as described in Chapter III, it is assumed that undersea threats are managed and prosecuted by theater ASW assets. Another important assumption to consider in this scenario and CONOPS is that the SAGs deployed to the South China Sea in response to the Chinese occupation of Natuna Besar are capable of performing their own air defense. In all, this tailored scenario and CONOPS focuses on how a U.S. Navy ship (i.e., the ships that comprise the two deployed SAGs) can successfully complete its own kill chain against an adversary surface combatant in an A2/AD environment.

In order to execute this mission, SAGs are first alerted to an AOU where a PLAN warship(s) is located. The source of this AOU (e.g., a national asset, such as a satellite or long-range reconnaissance aircraft), as described in Chapter III, is not considered within the scope of the project team's analysis. In order to elucidate the tactical scenario necessary to consider the employment of weapons, the project team asserts that as the two SAGs were transiting the Pacific Ocean enroute to the South China Sea, that Commander, U.S. Pacific Command (PACOM) issued an order declaring all Chinese forces in the South China Sea as hostile.

Once on-station at an appropriate standoff distance from the provided AOU with their ships in tactical formations, the SAG commanders deploy a remote ISR system capable of transiting to the AOU to identify, classify, and determine the actual location(s) of the PLAN vessel(s) to include position, course, and speed (PCS). With positive identification (PID) satisfied and the PCS of the PLAN surface combatant(s) communicated back to the SAGs, the order is given to engage. As the updated location

information is programmed into the launching ship's fire control system, the data is checked for accuracy by the fire control team's supervisor as weapons are readied for launch. With all pre-employment checklists complete, the launch ship fires a long-range ASCM from one of its vertical launch system (VLS) tubes. As the weapon travels to its target, the remote ISR system deployed by the SAG to investigate the AOU continues to monitor the target and, when appropriate, communicates updated PCS data to both the weapon in flight and the launching ship. The weapon adjusts its course in flight as necessary based upon any updated PCS information or "pop-up" threats it receives, ultimately guiding on and impacting its intended target. The remote ISR system remains on-station to perform BHA and/or BDA following weapon impact and relays this information back to the SAG. Based upon this BHA and/or BDA, an evaluation of weapon effectiveness and whether a second attack on the target is necessary can be made by the SAG commanders. With offensive operations complete, the remote ISR system is directed to either scuttle itself or return to an area where it can be recovered.

The above scenario's assumption that Chinese forces have been declared hostile is significant and warrants further explanation, as this was a point of much debate for the SEA-21A project team. There are two fundamentally different ways to interpret how this declaration affects mission execution for a U.S. surface combatant in an engagement scenario. One way to interpret this order: as soon as a Chinese ship is detected, the U.S. ship targets the vessel and immediately fires upon it. This implies that once the U.S. ship has adequately determined the AOU for the surface combatant of interest from a national asset, it deploys its organic OTHT platform. As soon as this OTHT platform is able to identify the vessel as a Chinese warship, the target is declared hostile, the weapon is launched, and BHA and/or BDA is collected.

A second way to interpret the order that all Chinese forces are "hostile" can be seen in a situation where a U.S. ship deploys its OTHT platform as soon as it is within range of an AOU for the Chinese surface combatant of interest. It does this, not for the purpose of immediate engagement, but in the interest of establishing and maintaining a firing solution on the target. In this case, the OTHT system can be used to fix and maintain the targeting

solution for extended periods of time while a decision on whether to engage it with weapons is evaluated.

3. Vignettes

- System Re-task – After successfully providing updated PCS to the ASCM in flight, the commander decides to re-task the remote ISR system to evaluate another AOU. The system determines it has enough power/fuel remaining to perform the updated task and complies. If it does not have the power/fuel required to perform the new mission, it informs the controlling ship and a recovery plan is initiated.
- Disposable System – When the commander launches the ISR system, they do so with the knowledge that the system is disposable and no security concerns exist. After completing the mission, depleted of fuel, or disabled or captured, the ISR system can be remotely commanded to declassify itself (i.e., erase any sensitive data or software) and is scuttled if still under positive control.
- Reusable system – As opposed to disposing of it as previously described, the ISR system is recovered for future use. When the system has completed its mission or reaches a minimum fuel state, it returns to an area where it can be recovered.
- Persistent system – The system is prepositioned and called upon when directed. A unit commander has the ability to access the system at their discretion without any required communication with other units or higher C2 for access.
- Ship classes – The types of ships involved must be carefully analysed to ensure stakeholder satisfaction. With respect to potential PLAN force structures, traditional Chinese SAG architectures should be examined in addition to a possible distributed surface force. As for U.S. Navy force architectures, they could range for limited composition SAGs to a single ship. Based upon the scoped 2020 IOC, U.S. Navy surface combatant

candidates in the tasking statement's 2025-2030 timeframe are likely to be limited to *Zumwalt*-class DDs and Flight III *Arleigh Burke*-class DDGs, and *Freedom* and *Independence*-class fast frigates (FFs, formally known as littoral combat ships (LCSs)). These ships represent those most likely to be employed by the U.S. Navy in the established time frame due to the excessive time required to conceptualize, design, built, test, and procure new classes of surface combatants. While FFs do not current possess the capability to accommodate a long-range anti-ship missile, upgrades to its modular design and configuration are likely and may provide an opportunity for future growth. However, even with its offensive shortcoming, FF is still likely to be a member of U.S. Navy SAGs tasked with conducting operations in littoral environments, such as that of the project team's proposed scenario.

4. Area of Uncertainty Determination

As described in the scenario narrative, the vicinity of the precipitating events is generally centered around the island of Natuna Besar in the southern end of the South China Sea. To facilitate further analysis in later steps of the SE process, a more precise location and size of a representative AOU was determined. The point of this analysis was to quantify where the adversary is likely to operate, as well as the size of the corresponding search area that U.S. surface combatants will be required to sanitize. This allowed the SEA-21A project team to establish a standardized AO within which to compare different alternatives.

Within any AOU, there are likely to be a number of non-combatant surface vessels (often classified as "white shipping") that present a marine clutter problem for a hunter-killer SAG to solve. These contacts must be properly classified and/or identified in order to mitigate any potential collateral damage concerns before engaging a target in the AOU. Figure 10 depicts all registered marine traffic in the vicinity of Natuna Besar for the duration of the 2014 calendar year. In the image presented in Figure 10, blue dots represent passenger vessels, green dots represent cargo vessels, and red dots represent tankers. Additionally, Figure 10 reveals two significant sea lanes near the island of Natuna Besar.

The lane that passes to the northwest of the island is highly utilized by shipping vessels while the lane intersection to its south is frequently used by passenger vessels. These areas of marine traffic are highly susceptible to control if a Chinese invasion of Natuna Besar were to occur.

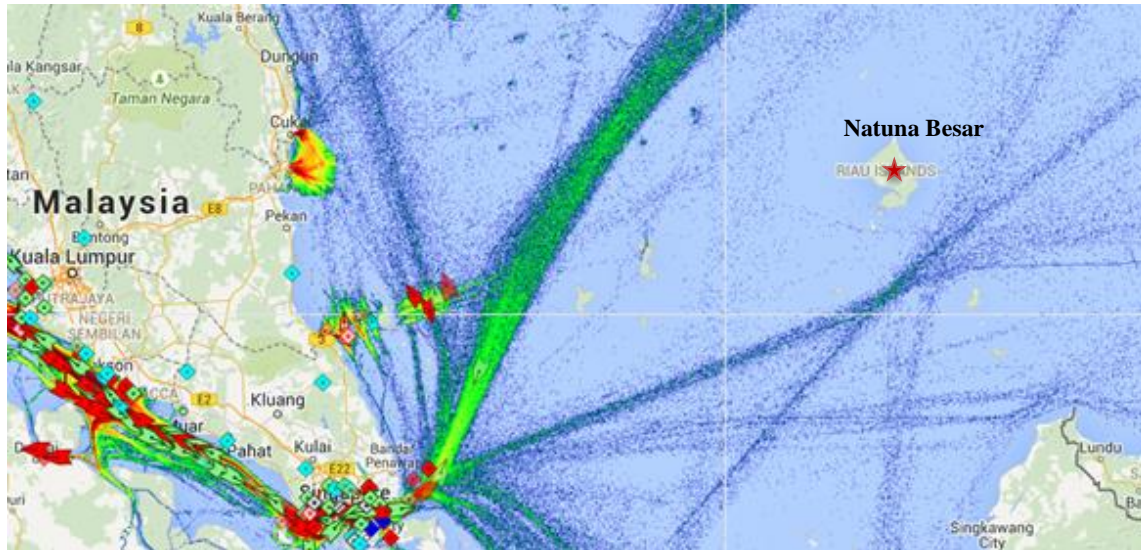

Figure 10. Marine Traffic in the Vicinity of Natuna Besar (from Marine Traffic 2015)

Measurement of the northwestern shipping lane (the busier and larger of the two significant sea lanes) yields an approximate 26 nm by 26 nm box. This is a relatively large area to consider for an AOU when compared to the actual size of the shipping lane itself, but in doing so makes the project team’s modeling efforts more robust. By definition, a larger area is more challenging to search. Therefore, making the AOU physically larger than any representative shipping lane ensured that the project team’s recommended design solution would be able meet detection requirements in nearly any representative scenario. For the purposes of the SEA-21 project team’s analysis, it is important to note that any adversary surface combatants will *always* begin any combat scenario within this 26 nm by 26 nm AOU. This assumption is based on the events of the scenario narrative and is done in an effort to localize an adversary’s threat sector before the ship(s) of a hunger-killer SAG is unknowingly defensive (i.e., inside an adversary’s weapons engagement envelope).

5. Present Day Scenario

In order to validate any analysis performed with the scenario as a base, the narrative should be transplanted to present-day 2015. This provides the SEA-21A team with known variables and ensures that models generated by the team using current data are applicable, bringing to light any existing capability gaps or shortfalls. Once a model is validated by the 2015 scenario, it will be updated to reflect the proposed 2025–2030 narrative. To bring the proposed scenario to the year 2015, very few, but significant, details must be changed. Some of these details include:

- Ship classes – Current PLAN ships should be modelled with traditional SAG architectures. Similarly, U.S. Navy combatants considered for use should be limited to Flight II *Arleigh Burke*-class DDGs or *Ticonderoga*-class guided missile cruisers (CGs) with RGM-84 Harpoon missiles; and
- CSG support – Currently there are no DF-21 batteries located outside of mainland China. Therefore, the CSG is not completely denied access to the South China Sea. Current ship capabilities will be analysed with CSG support in order to accurately capture the methods and performance of current operations. Once complete, the scenario can then be re-examined without CSG support in order to identify existing CONOPS and weapon/sensor capability gaps and shortfalls.

B. EMERGING REQUIREMENTS AND PRELIMINARY DESIGN

From the general narrative, several requirements have already begun to emerge. To fulfill the purpose of the narrative, the following requirements are captured and carry forward in the systems engineering process:

- Susceptibility – The proposed SoS shall reduce the overall risk to the individual ship or SAG when performing OTHT;
- Organic Capability – The use and employment of the OTHT system shall not require communication or approval for employment from an entity outside of the individual ship or SAG. It shall be rapidly deployable and/or

recoverable by a ship; or in the case of a prepositioned design, accessible for use by the ship's or SAG's commander as required; and

- Interoperability and Compatibility – The SoS shall be capable of operating from one or a combination of *Zumwalt*-class DDs and Flight III *Arleigh Burke*-class DDGs, and *Freedom* or *Independence*-class FF ships while also remaining interoperable with proposed SAG architectures and compatible with the latest generation of surface-based weaponry.

1. Requirements Analysis and MOEs, MOPs, and COIs

The requirements of SEA-21A's SoS were obtained from a complete stakeholder analysis and further derived from the ensuing functional analysis. Requirements are systems-level specifications that the system must be able to perform and are analogous to measures of performance (MOPs). Requirements are defined as “a condition or capability needed by a user to solve a problem or achieve an objective” (ISO/ISEC/IEEE 2010). Similar to MOPs, these systems-level specifications delineate what the system must be able to perform. For this definition, our user could be the end-level user or, more importantly, our stakeholders.

Measures of Effectiveness (MOEs) are defined as:

- “The data used to measure the military effect (mission accomplishment) that comes from the use of the system in its expected environment. That environment includes the system under test and all interrelated systems, that is, the planned or expected environment in terms of weapons, sensors, command and control, and platforms, as appropriate, needed to accomplish an end-to-end mission in combat” (Defense Acquisition University 2012).; and
- Quantifiable elements of operational effectiveness used in comparing systems or concepts or estimating the contribution of a system or concept to the effectiveness of a military force. They express the extent to which a

system accomplishes or supports a military mission (Department of the Army 2003).

Measures of Performance are defined as:

- “System-particular performance parameters, such as speed, payload, range, time-on-station, frequency, or other distinctly quantifiable performance features. Several MOPs may be related to the achievement of a particular MOE” (Defense Acquisition University 2012); and
- Quantifiable units of measure (such as miles per hour) that describe the manner in which a given function or task should be accomplished (Department of the Army 2003).

Requirements are also typically articulated through the use of “shall” statements in order to signify their importance while providing quantitative measures to ensure that system of SoS meets stakeholders’ expectations of its operational capability. Additionally, a system’s requirements are separated by those that are related to the functions of the system and those “-ilities” that comprise system operability and maintainability. This also encompasses the suitability of the entire system and can be captured by defining Critical Operational Issues (COIs) or Critical Operational Issues and Criteria (COIC).

COI/COIC are defined by both the U.S. Navy and the U.S. Army:

- COI/COIC are key operational effectiveness or suitability issues that must be examined to determine the system's capability to perform its mission. COI/COIC must be relevant to the required capabilities and of key importance to the system being operationally effective and operationally. A COI/COIC is normally phrased as a question that must be answered in the affirmative to properly evaluate operational effectiveness (e.g., “Will the system detect the threat in a combat environment at adequate range to allow successful engagement?”) and operational suitability (e.g., “Will the system be safe to operate in a combat environment?). COIs/COICs are critical

elements or operational mission objectives that must be examined, are related to MOEs (Defense Acquisition University 2012); and

- Key operational concerns, with bottom line standards of performance that, if satisfied, signify the system will fulfil operational requirements. The COI/COIC denotes the inability of the SoS to perform set criteria. COI/COIC are few in number, reflecting total operational system concern and employing higher order measures (Department of the Army 2003).

COIs specific to the OTHT platform for SEA-21A’s SoS are listed in Table 4.

Table 4. OTHT Platform Critical Operational Issues

COI	Issue	Question
1	Endurance	Is the endurance of the OTHT platform sufficient to accomplish the mission?
2	Transportability	Can the OTHT platform be launched and recovered from DDG/FF/CG platforms?
3	Compatibility	Are the OTHT platform and OTH weapon compatible with DDG/FF/CG mission systems?
4	Interoperability	Is the OTHT platform interoperable with other naval assets to enhance mission accomplishment?
5	Command and Control (C2)	Can C2 easily interact with the OTHT platform to accomplish the mission?
6	Sensor Effectiveness	Are the OTHT platform’s sensor capabilities sufficient for mission accomplishment?
7	Employment	Can the OTHT platform be employed in a sufficient amount of time to accomplish the mission?
8	Human Systems Integration (HSI)	Can users redirect the OTHT platform to an updated target AOU?
9	Security	Can the OTHT platform prevent disclosure of classified data?
10	Availability	Is the OTHT platform available to perform the mission?

In order for the project team to transition to conceptual system design, each of the COIs described in Table 4 were broken down into parts. These specific MOEs, MOPs, and design requirements (DRs) define what the system must do before the consideration of candidate system solutions can begin. Using such an approach permits the narrowing of possible system design solutions without eliminating potential systems due to bias. The SEA-21A project team used the COIs identified in Table 4 and decomposed them into respective MOEs, MOPs, and design requirements (DRs):

COI 1 – Endurance

MOE 1.1 – On station time

MOP 1.1.1 – Average time on station

DR 1.1.1.1 – Area covered

DR 1.1.1.2 – Weight

MOE 1.2 – Fuel Efficiency

MOP 1.2.1 – Fuel capacity (battery, liquid, solid, etc.)

MOP 1.2.2 – Fuel burn rate (per unit time)

MOE 1.3 – Reusability

MOE 1.4 – Quantity

COI 2 – Transportability

MOE 2.1 – Ability to integrate OTHT platform/long-range ASuW weapon into FF/CG/DDG

MOP 2.1.1 – Size of OTHT platform/long-range ASuW weapon and support equipment footprints when crated

MOE 2.2 – Capability for the OTHT platform/long-range ASuW weapon to be delivered to FF/CG/DDG during RAS/VERTREP

COI 3 – Compatibility

MOE 3.1 – Mission equipment availability

MOE 3.2 – Capability to work with existing ship’s hardware

MOE 3.3 – Capability to provide mid-course updates to ASuW weapon

COI 4 – Interoperability

MOE 4.1 – Capability to pass information to non-assigned units

MOE 4.2 – Capability of OTHT platform to receive data from non-organic units

COI 5 – Command and Control (C2)

MOE 5.1 – Operator dependency

MOP 5.1.1 – Time required for operator to update the OTHT platform (e.g., reaction time)

COI 6 – Sensor Effectiveness

MOE 6.1 – Detection range

MOP 6.1.1 – Average range of target at first detection

MOE 6.2 – Search rate

MOP 6.2.1 – Sweep width

MOP 6.2.2 – Area searched per designated time period

MOE 6.3 – Area coverage

COI 7 – Employment

MOE 7.1 – Ability to successfully launch and recover the OTHT platform

MOE 7.2 – Capability to target an OTH surface vessel using targeting information obtained from the OTHT platform

MOE 7.3 – Ability to successfully launch and guide a long-range ASuW weapon to impact against an OTH surface target

COI 8 – Human Systems Integration (HSI)

MOE 8.1 – Extensibility of the system

MOE 8.2 – Adaptability of the system to new users

MOE 8.3 – Usability of the system

COI 9 -Security

MOE 9.1 – Vulnerability of the SoS to intrusion/attack

MOE 9.2 – Ability to autonomously or remotely declassify the OTHT platform

MOE 9.3 – Ability of the OTHT platform to scuttle itself

COI 10 - Availability

MOE 10.1 – Availability of the OTH system

MOP 10.1.1 – Percent of time available

2. Conceptual System Design

As the SEA-21A project team moved into the conceptual system design phase, the preliminary design requirements began to evolve from the previously identified SoS requirements. This set of requirements, a representative maintenance and support concept, as well as the identification and prioritization of technical performance measures help to translate system operational requirements into guidelines for the SoS's ultimate design. It should be noted that such system operational requirements should be identified and defined well prior to considering detailed design requirements.

As the project team transitioned to the process of conceptual system design, the SoS operational requirements were mapped to defined objective and threshold values. Specifying threshold values ensures that at least the minimum systems-level requirements are met, while providing objective values ensures that the system will be optimized within the constraints of the requirements (MITRE 2013). Using this process, the SEA-21A project team derived the requirements listed in Table 5 and identified a representative objective and threshold value as necessary. The objective is the highest desired requirement, while the threshold value is the absolute minimum the system must achieve. Upon completion of this process, and with either or both the objective or threshold value satisfied, the process of developing preliminary system architectures by the project team began.

Table 5. SEA-21A Conceptual Requirements, Objectives, and Thresholds

Requirement	Objective	Threshold
The SoS's OTH platform shall be unmanned	N/A	N/A
The SoS shall be interoperable with CG, DDG, FF, and future classes	System is interoperable with all classes	System is interoperable with DDG and FF
The SoS's OTH platform shall allow the host ship to build a surface picture well beyond the limits of its organic sensors	500 nm	250 nm
The SoS's OTH platform shall be capable of extended loiter/on-station times	12 hours	6 hours
The SoS's OTH platform shall be capable of collecting BHA and/or BDA	Transmit BHA and/or BDA using full-motion video (FMV)	Record FMV and/or screen captures for delayed transmission or post-flight download
The SoS's OTH platform shall be capable of transmitting updated targeting information to the weapons(s) inflight	One inflight update	Multiple inflight updates
The SoS's OTH platform shall be fully integrated into the ship upon which it is deployed	No contractor support is required during O&S periods	Minimal contractor support is required during operations and support periods
Once on-station within range of a specified AOU, the OTH platform shall determine and communicate contract(s) PCS	PCS data is collected passively	PCS data is collected actively
The SoS shall be capable of overcoming communications and precision navigation and timing (PNT) jamming	Minimum power level, frequency hopping communication systems	Execute pre-programmed profiles when jamming is encountered
The system shall support long-range ASuW OTH	500 nm	250 nm
The SoS's OTH platform shall not compromise classified data or technology	OTH platform declassifies itself autonomously	OTH platform declassifies itself remotely
SoS can organically access updated targeting information in near-real time	Real time data	Updates once every 30 s

3. Architecture Alternatives: Design and Selection

The design of a system's or SoS's architecture is a major component of the systems engineering process. When designing a system or SoS architecture, several methodologies are available for consideration. Some of these methodologies include: normative, or solution-based; rational, or method-based; participative, or stakeholder-based; and heuristic, or based on lessons learned. In the normative technique, architectures are formed as they exist in a common sense world according to masters of trade, civil codes, or accepted standards. Due to the slow nature of change of accepted standards and practices, the normative method is limited in that it cannot react to rapidly changing requirements or preferences. In a rational method, principles of recognized science and mathematics help the designers to achieve an analytical result to the defined problem. Both the normative and rational methods use a science-based approach to provide the system or SoS architect a standard and accepted way of designing system architectures (Maier and Rechtin 2009).

With a variety of methods available to the systems architect, the designing of systems architectures can really be considered an art as it allows them to operate in a realm where data might not be easily quantifiable or areas where nuances are appreciated in fine-tuned design. The participative and heuristic methodologies can help guide the architect through such realms. In using the former, stakeholders are encouraged to interact with the system architect to mutually agree upon final design parameters using the concept of concurrent engineering. For example, using participative methodology would allow for a greater consensus on systems that directly impact human safety or survival. A heuristics methodology uses a more straightforward approach to systems architecting by making system statements from collective experience and best practices in order to describe to how a representative system architecture should exist. These heuristic statements provide a wealth of knowledge regarding commonly experienced problems in similar system architectures and are usually very practical in their approaches to solving them.

Overall, the general process of architecture design requires ideas that will be able to fulfill the SoS's requirements. Simple brainstorming and group discussion helps to develop and refine potential architectures while also triggering ideas that can be explored

further and potentially modelled. The SEA-21A project team explored possibilities in various potential architectures by applying a mixture of heuristics and participative technologies. This served as a basis for comparison and evaluation to determine a finalized list of candidate architectures that would best meet the SoS's requirements.

The candidate architectures described below represent the beginning efforts of the SEA-21A project team's architecture selection process. Each of the architectures contains a brief description of how each may fulfill the requirements of the SoS, as well as possible shortcomings. The following architectures serve as the foundation for the SEA-21A's modeling efforts and will lead to a short-list of alternatives to tested and analyzed as the project team moves toward a final recommended SoS design solution:

- **Single, Long-Range Unmanned Aerial Vehicle (UAV)** – Possesses the endurance to transit, search, localize, track, and send targeting information back to the “shooter” platform. This should be a recoverable/reusable system that can also be relieved by a duplicate system as required. A system such as this would be in a scenario that demanded a persistent OTH surface picture/ISR presence;
- **Multiple, Smaller UAVs** – This system architecture builds upon the single, long-range UAV concept. This concept would undoubtedly require trade-offs endurance, speed, and payload (i.e., sensor suite/capabilities). As a result, the host platform would need to be much closer to the AOU than the single, long-range UAV concept, which could place the ship within an adversary's engagement range;
- **Undersea Network (Stationary)** – The undersea network architecture is similar to the current day sound surveillance systems (SOSUS) installed on the floors of the Atlantic and Pacific oceans, but would also likely include the use of small unmanned undersea vehicle (UUV) assets that would surveil an area of interest for adversary surface contacts. Once a contact of interest is identified, the system would relay targetable data to networked U.S. surface combatants for potential engagement;

- **Solar-Powered Aerostat/High-Altitude Balloon/Blimp** – This architecture could be composed of a variety of lighter-than-air systems, such as the Joint Land attack Elevated Netted Sensor (JLENS; 10,000 ft altitude with radar coverage of up 340nm) currently being tested at the U.S. Army’s Aberdeen Proving Ground in Maryland (Defense Update 2014). The primary drawback of the aerostat is its size and transportability. The aerostat itself is as large as a surface combatant, and although it can fly higher and stay aloft for very long periods of time, it is also susceptible to local weather patterns, which may make tethering it to a surface combatant or support ship infeasible;
- **UAV ISR and Weapons Platform** – This architecture is an “all-in-one” design, similar to the MQ-1 Predator and MQ-9 Reaper currently in use with the U.S. Air Force. This single-UAV construct would be able to perform all mission subsets, to include completing the kill chain. However, the required weapon and sensor payloads of this construct would dictate size, launch, bring-back, and recovery constraints that may not be feasible for DDGs/CGs/FFs at sea;
- **Nano-Drones Deployed from a High-Speed, Disposable Vehicle (Swarm)** – This architecture would utilize the payload bay of an existing sea-launched missile to be flown to the AOU and then dispensed. These numerous nano-drones would then saturate the AOU in order to quickly detect, classify, and relay positioning information regarding adversary surface combatants back to the host platform. An architecture such as this would require that the system be expendable with each nano-drone’s sensor and communications capabilities likely diminished due to its small size;
- **Armed LDUUV** – Utilizing an armed LDUUV to act as a weapons delivery vehicle once an adversary target is located is only half of the equation. A system construct of this type would require queuing (likely through an undersea network) in order to utilize its weapon(s) against an adversary surface combatant. Due to its size, slow speed, and dependency on

underwater communications, utilizing an LDUUV in an organic OTHT surface-based construct would be very challenging;

- **Low-Observable Mobile Surface Network** – This architecture closely resembles that of a pre-positioned network. The use of low-observable craft would give ample opportunity to sneak into contested sea space in order to provide actionable ISR to a shooting platform. This architecture is very slow to build (i.e., it would need to be deployed or positioned well prior to an anticipated conflict), would present a hazard to sea surface navigation, and may be easily detected/compromised/disabled by an adversary due to the fact that it would remain relatively stationary on the water’s surface;
- **Persistent Littoral Undersea Surveillance (PLUS)** – This architecture is another pre-positioned network variant that, like the low-observable surface network, would need to be deployed or staged prior to conflict. Unlike SOSUS, this system would be easier to retrieve and repair, and would provide more precise and actionable data for a shooting platform to refine a targets position within an AOU;
- **Biological Assets (Dolphins, Pigeons, Seabirds, Sea Life Monitoring)** – A construct such as this would have to expand on existing programs due to the length of time required to establish, develop, procure, and deploy an architecture that utilized sea life a SoS. The sea life would be used to gather data on the movement of adversary combatants that might help to reduce a given AOU. However, the sea life may not be able to provide the fidelity required for targeting unless the assets were able to carry a robust sensor package;
- **Biomimicry** – Monitor the sounds of snapping shrimp, whales, etc. to gain information on the possible movements of adversary combatants. In building an historical database, conclusions could be drawn from gathered data to help classify and ultimately locate a class of ship based on the frequency and characteristics of the surrounding animal sounds. Utilizing an architecture such as this would be similar to “thumb printing” an

adversary surface combatant to the biological cries of ocean life, and would require the use of an undersea network to monitor and record these cries;

- **Electronic Attack (EA)** – The use of an electromagnetic pulse (EMP) weapon would be a single-shot that would be able to render all contacts in a given AOU electronically inert. While there are many possible drawbacks to such a construct, this architecture would affect neutral surface vessels in the AOU, may violate existing treaties, and could result in immediate conflict escalation;
- **Shipborne Railgun with Steerable Projectile** – The use of such an architecture would rely on off-board cueing from an OTHT platform to update the AOU or target data for the inbound projectile. The primary drawback from such an architecture is that the current range for such a projectile is on the order 100 nm (BAE Systems 2015) when this study’s problem definition and stakeholder analysis has dictated a much greater range;
- **Offensive Laser Weapons** – A construct such as this would require laser use on an UAV in order to provide the standoff ranges and communications required. Use of this construct on a USV would limit its range to line of sight. Such an architecture could utilize the research and development efforts of the U.S. Air Force’s airborne laser program (Boeing YAL-1A) that was cancelled in 2012;
- **Biofouling** – This construct would require a way to implant a fast-growing kelp-like substance into an area where adversary surface combatants may be transiting. These non-kinetic minefields of kelp would foul a ship’s underwater vents and likely render enemy surface combatants dead in the water. Just as the use of an EMP weapon, its use would likely present a hazard to neutral surface traffic;
- **Cyber Attack** – An architecture that exploits an adversary’s use of cyberspace could degrade their ability to dynamically target friendly surface combatants if infections malware activates when the adversary attempts to

engage by disabling its fire control systems or spoofing its targeting system's data. This construct would require cyber infiltration of a warship at sea and could be vulnerable to detection and/or manipulation by an adversary; and

- **Tailorable Remote Unmanned Combat Craft (TRUCC)** – This architecture is comprised of a swarm of unmanned surface vehicles with sensor and communications suites capable of relaying targeting information to a shooter platform. The primary drawback of this architecture is that TRUCCs are relatively small boats that could be affected by both elevated sea states and line-of-sight (LOS) communications issues.

These potential architectures and constructs are the result of the SEA-21A project team's research and associated group discussions. While some of these proposed constructs are unlikely, it was important to the credibility of the study that all potential avenues, domains, and current research were explored in order to ensure that the short-list of candidate architectures chosen for additional analysis are justified. While the aforementioned list was extensive, attempts to choose a viable system were made using two different methods. The first was to assign point values of 0, 0.5, and 1.0 to each construct's current and/or future development level in some of the key COIs, as well as technological maturity. This breakdown is summarized in Table 6.

Table 6. SEA-21A OTHT Individual Construct Weighting

Construct	Transportability	Interoperability	Compatibility	Sensor Effectiveness	Tech Maturity	Total Score
Single UAV	1.0	1.0	1.0	1.0	1.0	5.0
Multiple UAVs	1.0	0.5	1.0	1.0	0.5	4.0
Undersea Network	1.0	1.0	1.0	1.0	0.5	4.5
Aerostat	0.0	1.0	1.0	1.0	1.0	4.0
Armed UAV	0.0	1.0	0.5	1.0	1.0	3.5
Nano-UAVs (Swarm)	1.0	1.0	1.0	0.5	0.0	3.5
LDUUV	0.0	0.5	0.0	1.0	0.5	2.0
Mobile Surface Network	1.0	1.0	1.0	1.0	1.0	5.0
PLUS	1.0	0.5	0.5	0.5	0.5	3.0
Biological Assets	0.0	0.0	0.0	0.5	0.0	0.5
Biomimicry	0.0	0.0	0.0	0.5	0.0	0.5
Electronic Attack	0.5	0.5	0.5	0.0	0.5	2.0
Railgun	0.5	0.5	0.5	0.0	0.5	2.0
Laser Weapons	1.0	0.5	0.5	0.5	0.5	3.0
Biofouling	0.0	0.0	0.5	0.0	0.0	0.5
Cyber Attack	0.5	1.0	1.0	0.0	0.5	3.0
TRUCC	0.0	1.0	1.0	1.0	0.5	3.5

The constructs summarized in Table 6 were then categorized and their scores averaged. This was done in an effort to quantify how the categories ranked among one another, with the highest average category scores likely to yield the most suitable architectures for continued analysis. These average scores are shown in Table 7.

Table 7. Construct Category Comparison

Category	Possible Constructs	Average Total Score
Prepositioned Network	- Stationary Undersea - Low-Observable Surface - PLUS	4.17
UAV	- Single/Multiple UAVs - Armed UAV - Nano Drones - Aerostat	4.00
USV	- TRUCC	3.5
Other	- Electronic Attack - Railgun - Laser Weapons - Cyber Attack	2.5
UUV	- Armed LDUUV	2.0
Biological	- Biological Assets - Biomimicry - Biofouling	0.5

It is clear from the results summarized in both Table 6 and

Table 7 that the technological maturity of the constructs in the biologics and UUV categories is the primary driver in their exclusion from consideration in the team’s recommended architecture for the 2025–2030 timeframe. These construct weighting results emphasize the need for the SEA-21A project team to focus on existing technologies and platform designs in the analysis of candidate solution architectures that could reach IOC by the year 2020.

4. Ethical Considerations

When considering autonomous and semi-autonomous components of SEA-21A’s recommended SoS design, the question inevitably turns to the ethical considerations

involved with allowing a machine to perform F2T2EA functions in the absence of human supervision. Much of this concern can be avoided by deliberately requiring consent from qualified personnel before weapons are actually released. Additionally, providing the capability for an abort or override of released weapons at any point in the kill chain (even up to the moments prior to impact) will also be assumed to assuage ethical concerns with so-called “lethal autonomy.”

As will be discussed later in Chapter VII, the architectures under consideration will be assumed to rely on human intervention for weapons employment. The varying levels of autonomy (i.e., automation) in candidate systems will be limited to navigation, sensor employment, and system self-monitoring. The possible exception to this is the potential incorporation of LDUUVs into an undersea network architecture, which may lead to concerns with hazards to navigation in waters used in commercial shipping, as presented by Rob Sparrow in a CRUSER Colloquium titled “When Robots Rule the Waves?” on March 17, 2015 at the Naval Postgraduate School, Monterey, CA). However, this concern is normally limited to armed USV and UUV platforms.

VI. MODELING AND SIMULATION

A. THE PROJECT TEAM'S APPROACH

As the SEA-21A project team's revised tasking statement requires the evaluation of potential OTHH surface-on-surface engagement concepts for the U.S. Navy in the 2025–2030 timeframe, rapid advances in military technologies, such as that characteristic of autonomous systems, means that conflicts from 2025 onwards are likely to involve future systems. With that said, the crux of this study's concept evaluation is likely to concern existing systems or those currently in the latter stages of development than a conceptual model on the drawing board today.

From the beginning, the project team was faced with the dilemma of evaluating systems with very little to no existing data. To overcome this hurdle, the team invested in modeling those systems using mathematical models. Through the use of computer-based simulation, these models were implemented with several variations in an effort to produce complex scenarios for the 2025–2030 timeframe of interest. These modeling and simulation (M&S) capabilities provided the SEA-21A project team with the means to better understand future systems while gaining insight into how individual elements interact with and affect the simulation environment. This approach and how it feeds this report is depicted in Figure 11.

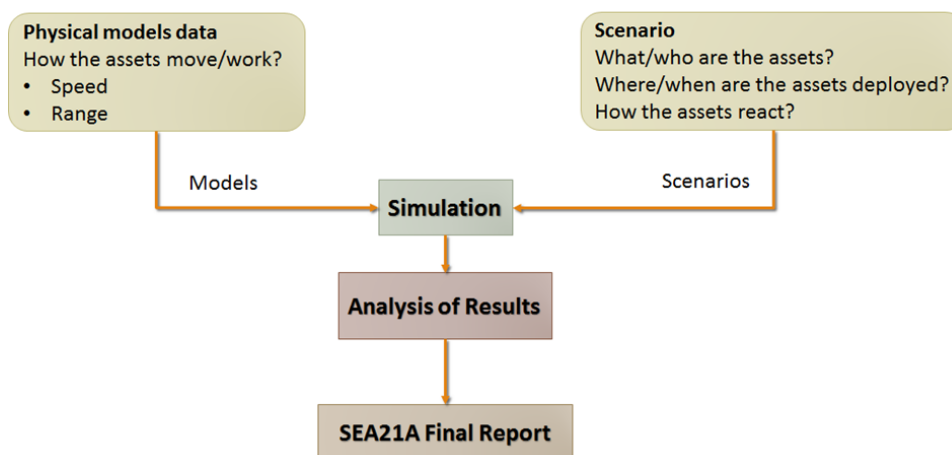

Figure 11. Modeling and Simulation Approach

The use of modeling and simulation allows the project team to quantitatively determine the best overall SoS design. Models are constructed to accurately represent the given scenario (e.g., search models, queuing models, etc.) and simulations of those models are executed to obtain a wide variety of output parameters. Through the analysis of the output data, the team may determine which system performs the best through the use of applicable MOEs and MOPs. The simulated environment marries the physical performance of future systems with the scenario's concept of operations. The results of which have been analyzed and used to support the SoS design recommendation in this report.

B. MODELING AND SIMULATION GOAL

The SEA-21A project team's modeling and simulation goal was to provide the capability to quantify the benefits of the different SoS candidate architectures. For a given area (e.g., a 26 nm by 26 nm AOU as described in Chapter V) in an OTHT mission, the most critical parameters in evaluating the performance of the SoS include the time required to detect an adversary surface combatant and the probability of doing so. These aspects and how they relate are depicted in Figure 12.

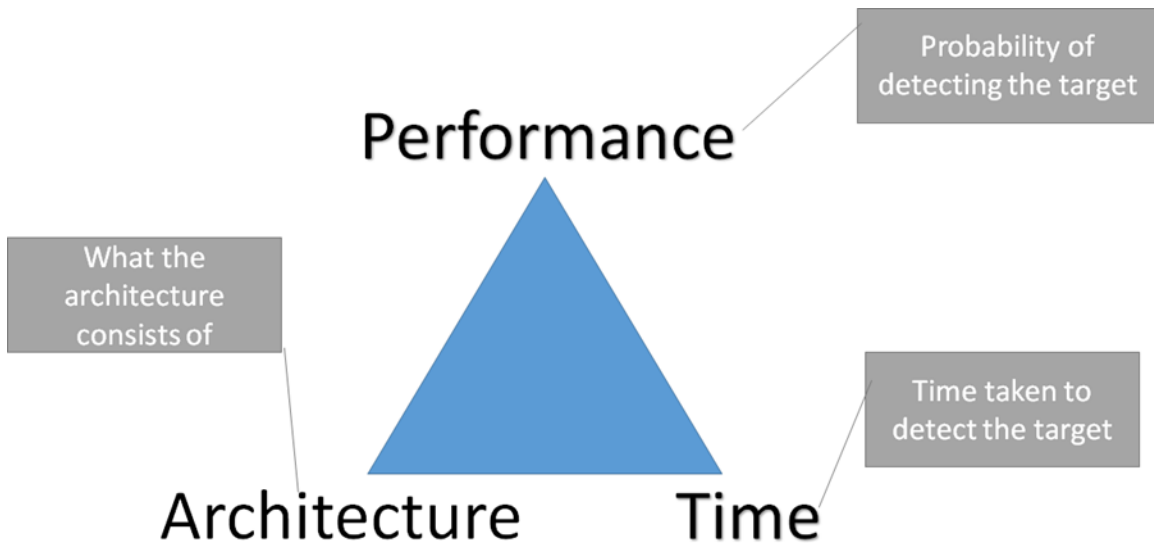

Figure 12. Relationship between Architecture, Performance and Time

M&S software tools were used to exercise the different architectures within a realistic 2025–2030 scenario simulation while the time and performance aspects of each architecture were compared with each other. If the scenario requires the ISR mission to be completed within a fixed timeframe, the M&S tool can determine the necessary detection probability of a given architecture. On the other hand, if a decision maker requires a particular probability of detecting the target, the time required to achieve that probability will be of interest.

C. HIGH-LEVEL CONSTRAINTS, LIMITATIONS, AND ASSUMPTIONS

1. Constraints

The SEA-21A project team defined a constraint as a restriction imposed by the sponsor (OPNAV N9I) that limits the project team’s options in conducting the study. The team’s M&S constraints for the study are summarized in Table 8.

Table 8. Modeling and Simulation Constraints

Constraint	Description
C1	All data used for modeling has to be unclassified All modeling software has to be unclassified
C2	The team needs to complete the analysis study within nine-month SEA-21 project time frame
C3	Weapon engagements will not be considered due to the unreliability of unclassified open-source data

2. Limitations

The project team defined a limitation as its inability to fully meet the study objectives or fully investigate the study issues. These limitations for the M&S effort are outlined in Table 9.

Table 9. Modeling and Simulation Limitations

Limitation	Description	Remarks
L1	<p>The impact of cyberspace on operations introduced significant complexity to models and scenarios alike.</p> <p>The international aspect of the project team prevented the procurement of adequate M&S software, as well as detailed (i.e., classified) data to properly analyze the impacts of this domain.</p>	See Assumption A1 in Table 10.
L2	Mobile undersea target simulation was not possible due to the classified nature of its associated data and information (e.g., submarines).	
L3	Detailed adversary surface combatant data are not available for modeling.	See Assumption A17 in Table 10.
L4	<p>Like cyberspace, the electronic warfare (EW) impact on operations introduces significant complexity to models and scenarios alike.</p> <p>The SEA-21A project team lacks credible and unclassified M&S software to analysis this domain.</p>	See Assumption A15 in Table 10.

3. Assumptions

The team defined an assumption as a statement related to the study that is taken as true in the absence of facts, often to accommodate one or more limitations. The M&S assumptions made by the SEA-21A project team modeling are described in Table 10 with the U.S. forces described as “Blue” and PLAN forces described as “Red.”

Table 10. Modeling and Simulation Assumptions

Assumption	Description
A1	Cyber impact is minimal due to Blue forces being isolated at sea. It is assumed that data links are secure and all information assurance (IA) policies are enforced.
A2	A worst-case threat scenario will be considered.
A3	Sea state and conditions (e.g., salinity) have no impact on modeling outcomes
A4	Only conventional (non-nuclear) warfare options are available
A5	No weapons employment has yet occurred by either side (Blue or Red)
A6	The use of aircraft carriers is precluded due to Red ASCMs/ASBMs
A7	The initial tactical scenario involves a single Blue ship vs. a single Red ship
A8	Red assets are deployed in a defensive posture
A9	Red assets are able to arrive on-station before Blue assets due to the area of operation's (AO) proximity to their logistics ports
A10	The initial red force assessment in the AO and AOU determination will be defined using non-organic national assets
A11	<p>Upon obtaining intelligence on Red assets, Blue assets will transit to the initial Red AO while maintaining adequate stand-off from Red weapon systems</p> <p>This distance will be the maximum weapons employment range of identified Red assets plus 50 nm. Blue assets will then consider launching the OTHT platform to search and classify Red assets in the AOU</p>
A12	Blue assets are victorious when Red forces are detected within the allocated mission threshold time
A13	The South China Sea serves as a representative littoral region for the study's scenario(s)
A14	Model input parameters are derived from unclassified open sources

Assumption	Description
A15	The impact of EW is minimal due to the strong electronic counter-countermeasures capability (ECCM) of both forces (Red/Blue)
A16	Red forces will not employ long-range ASCMs/ASBMs against Blue SAG(s)
A17	Open-source, unclassified data for Red force capabilities is adequate for the M&S purposes of this study

D. MODELING SOFTWARE OVERVIEW

1. EADSIM

The SEA-21A project team’s modeling and simulation efforts began with attempting to establish a suitable agent-based simulation environment using MATLAB. An agent-based simulation would allow the team to simulate individual entities and answer questions, such as force-on-force operational effectiveness. The team quickly scrapped this initial development effort after it became clear that too many resources were needed to implement a viable model in the software. The team’s attention then shifted to sourcing potential simulation programs from existing military simulation tools, with three potential frontrunners: Map Aware Non-Uniform Automata (MANA), Naval Simulation System (NSS), and Extended Air Defense Simulation (EADSIM).

At first glance, the NSS software appeared to be ideal for SEA-21A’s simulation purposes; however, it was not available for use by foreign nationals who comprise half of the SEA-21A project team. Between MANA and EADSIM, the latter possesses a comprehensive built-in reporting tool and has a wider user-base with over 390 agencies worldwide (Teledyne Brown Engineering Inc. 2005). It also comes with many generic unclassified models of existing military hardware, which the team could use to tailor prospective systems and technologies in the development of the final design recommendation.

Though consideration was given to using MANA and the software was available for use in this project, the project team ultimately selected EADSIM for its initial modeling

efforts. While EADSIM did not support the underwater environment like NSS, it was found to be the most suitable simulation tool for the scenario's environment after considering alternatives, constraints, and limitations. An overview of the EADSIM software and the different kinds of platforms and interactions that can be simulated is depicted in Figure 13.



Figure 13. EADSIM Overview (from Teledyne Brown Engineering Inc. 2005)

a. Modeling in EADSIM

By utilizing appropriate EADSIM models and representative scenarios, the SEA-21A project team was able to accurately and effectively represent current, as well as future combat systems and capabilities in a virtual environment. The EADSIM model use by the SEA-21A team aids in the elucidation of system requirements, components, and interactions between the components. By simulating different variations of the same basic model, we can easily test conditions that are too difficult or costly using real-world systems. Similarly, by altering the model and simulation input parameters, we can quickly and easily obtain output parameters for a wide variety of scenarios.

The unclassified version of EADSIM available to the SEA-21A project team contains configurable generic models of platforms, networks and sensors, customizable rules of engagement and behaviors, as well as simulation engine and playback capabilities. A scenario can easily be represented by applying these models and rules to individual

entities and then deploying them on a virtual map in the simulation. Such a virtual map could be constructed using Digital Terrain Elevation Data (DTED) from open sources that typically provide a resolution of 30 arc seconds (approximately 900 meters) between each cells. With that said, it is also possible to procure and build higher resolution maps when required. An EADSIM image of the scenario’s geographic region in the South China Sea showing DTED0 imagery provided by the National Geospatial Intelligence Agency is depicted in Figure 14.

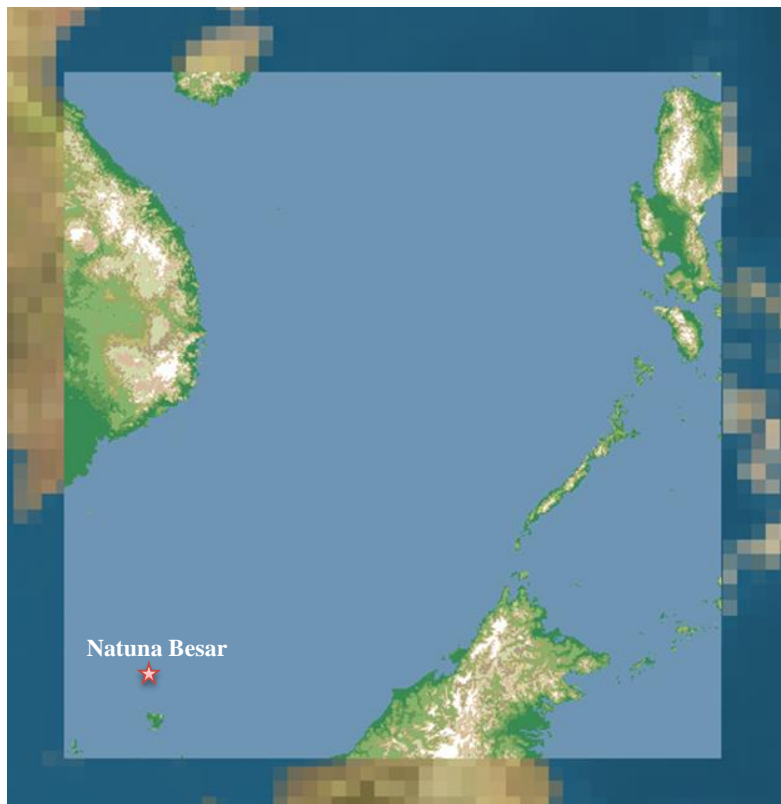

Figure 14. EADSIM DTED0 Image of the South China Sea (from National Geospatial Intelligence Agency 2005)

In EADSIM, the lowest level of data is an element. Other examples of elements inherent to the software include sensors, rule sets, communication devices, jammers, and weapons. These elements can be combined into systems that serve as general representations of each platform in a given scenario (e.g., a *Ticonderoga*-class CG may be represented by a generic cruiser system). Once a representative system has been

configured, another platform referencing this system may be added to the scenario as a unique entity with its own parameters, such as a name, identification code, grouping, and navigational routes (e.g., waypoints). This capability allowed the SEA-21A project team to create multiple entities of the same system type/class and station them in various locations within the software's virtual environment.

The Command, Control, Communications and Intelligence (C3I) model in EADSIM performs C2 decision processing, track processing, message processing, as well as engagement and weapon modeling for all platforms participating in the scenario. The communications process is being modelled by using messages sent from one entity to another through network equipment on the scenario's platforms. Individual networks may be defined for different groups of entities and can also be subjected to transmission delays and jamming by opposing forces. Similarly, entities possessing appropriate sensors may also detect and identify other entities and prosecute them as targets in future engagements. These identified targets may then be passed to other networked entities with long-range capabilities in the event that those entities lack the required sensor range to acquire the target on their own (e.g., the target is beyond the radar horizon). An example proof of concept scenario using EADSIM where a U.S. Navy SAG's surface search for a PLAN surface combatant is augmented by a nearby CSG's E-2D Hawkeye is depicted in Figure 15. Additional details regarding the scenario can be found in Appendix B.

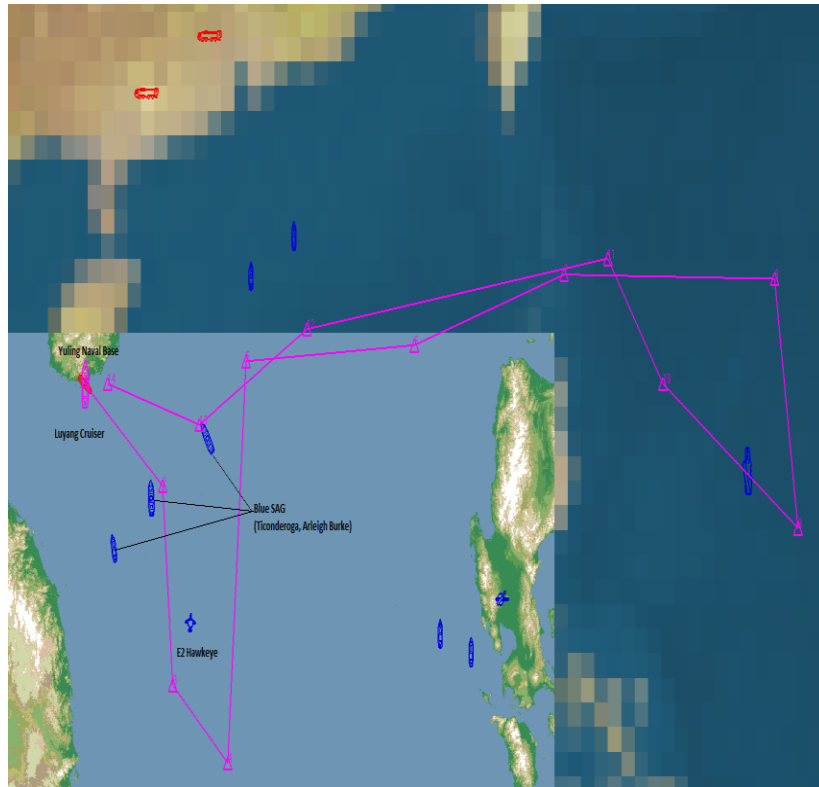

Figure 15. EADSIM Proof of Concept Scenario Depiction

b. Dropping EADSIM from the Modeling and Simulation Effort

During the project team’s second interim progress review (IPR) briefing, the EADSIM proof of concept scenario and other potential study scenarios were presented to SEA-21A sponsors and stakeholders. These scenarios were designed within a force-on-force context with weapon engagements and loss exchange ratios as the primary MOE. Information regarding system performance (e.g., probability of kill [P_k], engagement ranges, and speed) of weapons, sensors, and platforms was gathered using unclassified, open sources. These details can be found in Appendix B. During IPR2, concerns were expressed from those in attendance that the unclassified data used in building models could result in unrealistic or incorrect data and outcomes.

As a result, the audience advised the team to examine the front-end (search) portion of the OTHT mission instead. From this aspect, sea surface clutter and search coverage became the primary focus of the analysis. Due to the project team’s time constraints and inability to explore other classified agent-based modeling and simulation options, the SEA-

21A project team elected to drop EADSIM from the analysis effort in favor of examining other software tools that would not only be more efficient, but would also answer the clutter and search coverage questions.

2. ExtendSim

ExtendSim is an extremely powerful, yet easy-to-use, tool for simulating a wide variety of processes. These processes, as part of the overall system, are displayed as building blocks in an easy-to-use and logical format. Using this software, the team can predict the course and results of certain actions, identify problem areas before making recommendations, and determine which input variables have the most impact on the outcome (Imagine That Inc. 2013).

With the decision to move away from EADSIM, the SEA-21A project team elected to use ExtendSim to model the performance of the single-UAV architecture. While EADSIM is a very powerful tool capable of modeling many types of military systems, its inability to randomize units' positions and behaviors did not meet the project team's modeling needs. If the team would have chosen to move forward using EADSIM, it would either have to manually create hundreds of randomized scenarios to adequately address the true randomness involved, or be willing to accept over-simplified results – neither of these two approaches were acceptable to the project team. Since ExtendSim had been introduced and utilized in previous SEA curriculum courses, it was ultimately selected for use in modeling the single-UAV architecture. Within ExtendSim, the issues of randomizing units' positions and behaviors seen in EADSIM were easily and adequately addressed.

a. Modeling the UAV Candidate Architecture in ExtendSim

(1) Initial Model

An initial, basic scenario was developed to allow the team to manipulate various UAV parameters. This scenario involved a single adversary ship, a single U.S. ship, and a UAV launched from the U.S. ship. At the scenario's onset, the U.S. ship launched the UAV and it transited the open ocean until it reached the AOU containing the adversary ship. Upon reaching the search area, a mathematical search model was used to determine the

distribution of times it would take to find the adversary ship. After numerous simulation runs, statistical analysis of these stochastic results was performed and provided useful information for future analyses of architectures.

As with the construction of any model, assumptions have to be made. The SEA-21A project team's assumptions for this initial model included the following:

- The only asset moving in the scenario is the UAV. The project team assessed this to be a reasonable assumption based on the relatively short transit and search distances involved, as well as the relatively fast transit speeds of the UAV compared to the operating speeds of the ships;
- The U.S. ship will maintain a requisite standoff distance, remaining outside of the assessed maximum engagement range of the adversary's most capable surface-to-surface anti-ship missile;
- No clutter exists within the AOU (i.e., there are no merchants, trawlers, or other contacts that would cause a delay and/or misidentification of the adversary ship);
- Reliability of the U.S. UAV is 100%. In this initial model, the project team did not analyze mechanical or other failure mechanisms that could cause it to not perform its mission;
- The U.S. UAV is not susceptible to adversary self-defense weapons (i.e., it cannot be shot down or otherwise defeated);
- The probability of detection (P_d) of the adversary ship is 100% once the ship is inside the UAV's search width (i.e., there are no scenarios where the UAV will fail to complete a detection due to misidentification or a failed exhaustive search);
- The time for the UAV to transit to and from AOU is purely a function of distance and speed (no randomness was inserted into transit times); and
- The UAV is launched from the U.S. ship at time zero.

To model the search portion of the single-UAV architecture in ExtendSim, the project team elected to use some of the exhaustive search modeling techniques learned in

the Naval Tactical Analysis (OS3680) course taught at NPS. Exhaustive search makes a number of assumptions (Washburn 2002):

- The target is stationary (the speed of the UAV is much greater than that of both the U.S. ship and the adversary ship);
- The target location distribution is known;
- The detector is a cookie-cutter sensor with range R . This means that the sensor always detects the target within R and never detects targets beyond R ; and
- A “perfect” search is conducted. This means that there is no area searched twice, no area missed, and no additional area searched (other than the area, A , we are intending to search).

Variables used for the exhaustive search included the following:

- sweep width = $W = 2R$ (distance);
- search speed = V (distance/time);
- sweep rate = VW (area/time); and
- time of detection (a random variable) = T (time).

Using the team’s assumption that the position of the target (i.e., the adversary ship we are trying to find) is uniformly distributed over area A , the time to find the target for the U.S. UAV will be uniformly distributed from time zero (the instant the search is initiated in area A) until time $A/(VW)$ (the point in time in which every portion of area A has been searched) (Washburn 2002). This can be summarized by the following expression:

$$T \sim U [0, A/(VW)]$$

Implementing this equation into the ExtendSim model was relatively straightforward. A graphical depiction of this exhaustive search utilizing the uniform distribution previously discussed is shown in Figure 16.

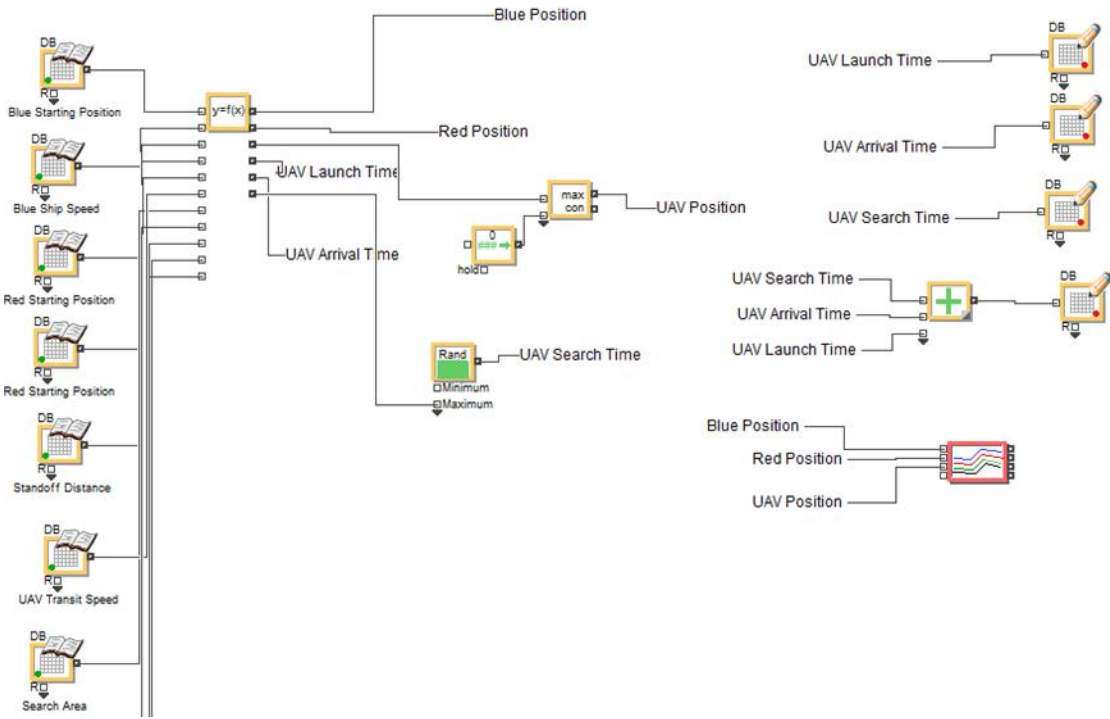

Figure 16. Initial ExtendSim Single-UAV Model Block Diagram

From left to right in Figure 16, the first process in the model is initialization of its input parameters from a database. These parameters include the U.S. ship's starting position and speed, the adversary ship's starting position and speed, AOU dimensions, etc. Next, an equation block (depicted in Figure 16) is used to delineate the necessary steps to calculate a majority of the data for the remainder of the model.

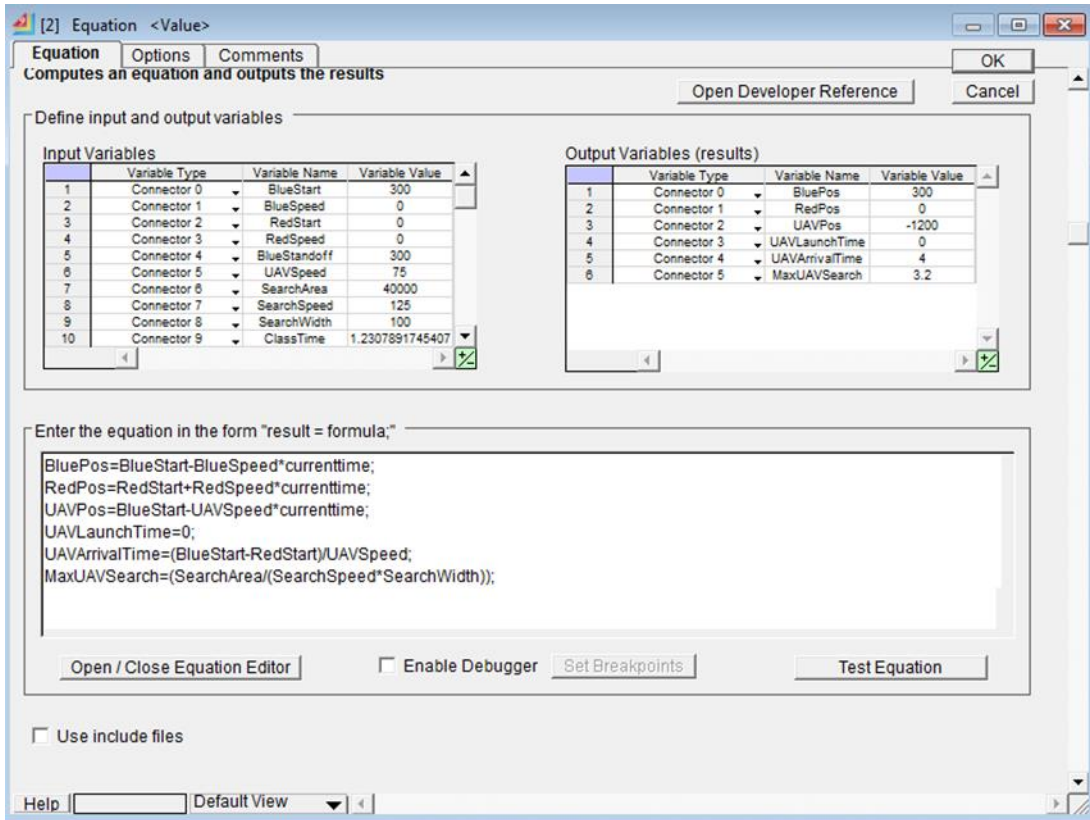

Figure 17. ExtendSim Single-UAV Model Equation Block

As shown in the equation block of Figure 17, one of the main assumptions in this initial model was that all units (except the UAV) are stationary. In other words, the position of the U.S. ship (BluePos) and adversary ship (RedPos) remain zero for the duration of every run. Additionally, UAVLaunchTime is set to 0 for the duration (i.e., the UAV is launched from the U.S. ship at the beginning of the simulation. This implies that the clock does not start until the initial adversary ship AOU is received by the U.S. ship and the UAV is prepped and launched. The time it takes for the UAV to reach the beginning of the search area (UAVArrivalTime) is a function of the U.S. ship and adversary ship positions, as well as the UAV's speed. Lastly, the time it would take the UAV to search the entire area is calculated using the equation for MaxUAVSearch. This value is entered downstream into the uniform distribution block to randomize the actual time it takes for the UAV to find the adversary ship.

This initial model was constructed and run numerous times in order to validate its methodology. While outputs were generated to ensure that they were reasonable, they are not presented here. This simplified model, however, served as the foundation for the construction of the final model presented in the following section. This final model and its outputs would ultimately be used to evaluate the single-UAV candidate architecture's performance effectiveness.

(2) Final Model

A second (and final) model was developed in order to evaluate varying UAV and ship parameters while utilizing a more realistic approach. The scenario used in this final model still involves a single U.S. ship searching an AOU for an adversary ship with its organic UAV. Just as in the initial model, the U.S. ship launches its UAV at time zero and the UAV transits the open water until it reaches the designated AOU. Upon the UAV's arrival, a mathematical search model is implemented to determine the distribution of times it would take to find the adversary ship. However, this new model addresses the fact that the adversary ship will be one of several, if not many, surface vessels present in the AOU. By accounting for this "clutter," the SEA-21A project team captured its impact on the time necessary to not only detect the adversary ship, but to also classify it and every other vessel in its search width. In this model, the project team has defined clutter as other surface assets (e.g., merchants, trawlers, sport fishermen, etc.) that interfere with the UAV's ability to effectively find the adversary ship. After five thousand iterations of the final model were executed for each of the five UAV system configurations (UAV1 through UAV5 and described later in this chapter in Table 11) was performed, statistical analysis of these results provided meaningful information for the comparison of the SEA-21A project team's UAV and PPN candidate architectures.

The final model utilizes all of the same assumptions from initial model with the following exceptions:

- clutter is no longer zero;
- clutter location(s) is/are uniformly distributed within the search area (i.e., the AOU);

- the number of clutter units is represented using a triangular distribution; and
- the time to investigate clutter is represented using a uniform distribution.

Just as in the initial model, the final UAV model utilizes an exhaustive search modeling technique learned in a previous NPS course in Monterey, CA taken by the SEA-21 cohort, titled OS3680 *Naval Tactical Analysis*. Similarly, the same exhaustive search assumptions still apply:

- the target is stationary (the speed of the UAV is much greater than that of both the U.S. ship and the adversary ship);
- the target location distribution is known;
- the detector is a cookie-cutter sensor with range R . This means that the sensor always detects the target within R and never detects targets beyond R ; and
- a “perfect” search is conducted. This means that there is no area searched twice, no area missed, and no additional area searched (other than the area, A , we are intending to search).

Variables used for the exhaustive search included the following:

- sweep width = $W = 2R$ (distance);
- search speed = V (distance/time);
- sweep rate = VW (area/time); and
- time of detection (a random variable) = T (time).

In modeling the clutter in this final model, the project team assumed that the clutter location is uniformly distributed throughout the search area and that the number of clutter elements within the AOU is represented by a triangular distribution. To determine the triangular distribution for the number of clutter vessels (N_c), the SEA-21A project team elected to model the amount of traffic passing through an area given at any given time (Jinhai 2014). Assuming a worst-case scenario in the vicinity of the Strait of Malacca, an upper bound of 500 was implemented in the ExtendSim model. As previously mentioned,

the positions of clutter vessels are distributed uniformly within the AOU and are represented in the final model by:

$$N_c \sim \text{Uniform}[0, 500]$$

Just as the number of clutter vessels in the AOU was represented in this final model, the time to classify it (T_c) was also simulated using a triangular distribution. The minimum time to classify was determined using autonomous classifying systems, while the maximum times were indicative of a man-in-the-loop process (U.S. Air Force 1998). Therefore, the triangular distribution for T_c (in seconds) is represented by:

$$T_c \sim \text{Triangular}[10, 15, 30 \text{ sec}]$$

The adversary ship's position in this final model is still assumed to be uniformly distributed over the search area A and the time for the U.S. ship's UAV to find it was considered to be a function of T_c . This encompasses the total elapsed time from the instant the search is initiated in area A and includes the UAV's investigation of the first contact (which could turn out to be the adversary asset) it sees until time $A/(VW) + N_c T_c$: the point in time in which every portion of area A has been searched plus the time to investigate the total amount of clutter assets (the number of assets N_c multiplied by the classification time T_c). This is summarized by the following relationship where the time to find the adversary ship (T_r) is modelled by:

$$T_r \sim \text{Uniform}[T_c, A/(VW) + N_c T_c]$$

Implementing the distribution assumptions and relationships summarized in the preceding paragraphs into the final UAV ExtendSim model required some slight modifications to the initial variant. The block diagram for this final UAV architecture ExtendSim model is depicted in Figure 18.

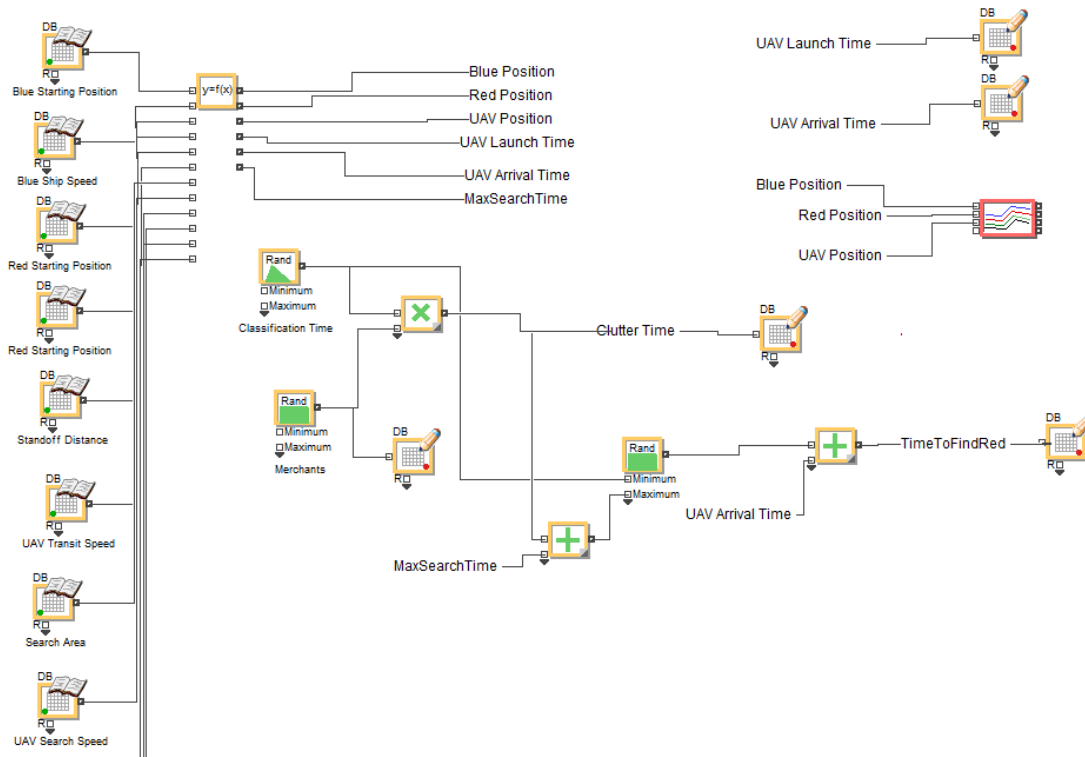

Figure 18. Final ExtendSim Single-UAV Model Block Diagram

The distinguishing feature of the final UAV architecture model, though similar to the initial model in structure and sequential flow, lies in its ability to account for clutter. The product of classification time (T_c) and the amount of clutter (N_c) yields the maximum amount of time required to classify all contacts ($N_c T_c$). When added to the maximum search time (A/VW), this new total time represents the longest amount of time it could take to find the adversary ship within a defined AOU. This maximum search time serves as the upper limit for the uniform distribution, while the minimum time to conduct the search (lower limit) can be represented by a scenario in which the adversary ship is immediately detected and classified the moment the UAV reaches the AOU and begins its search (i.e., exactly one T_c and zero search time).

With the model implemented in ExtendSim, the SEA-21A project team could now analyze the impact of different UAV characteristics on mission performance. Anticipating the comparative analysis to be conducted in Chapter VII, we identify five different UAV configurations that span the ranges and combinations of interest. The parameters for these

five UAV variants are summarized in Table 11. UAVs 1-3 are representative of small to mid-size UAV systems, such as the Boeing Insitu ScanEagle and MQ-21A Blackjack (see Appendix C), while UAVs 4-5 represent large UAV systems, such as the RQ-4 Global Hawk and the MQ-4 Triton. The associated speeds and ranges identified in Table 11 represent upper/lower bounds and midpoints of the UAV performance spectrum. This is further described in Chapter VII and Table 18.

Table 11. UAV Variants Input Parameters

Variant	Speed (kts)	Sensor Radius (nm)
UAV 1	70	30
UAV 2	70	230
UAV 3	110	130
UAV 4	150	30
UAV 5	150	230

Other UAV model input parameters for the simulation runs are shown in Table 12. As opposed to the parameters detailed in Table 11, these remained the same for each of the five UAV variants.

Table 12. UAV Model Input Parameter Values

Parameter	Value
Search Area	676 nm ²
U.S. Ship Standoff Distance	300 nm
Classification Time (T_c)	\sim <i>Triangular</i> [10, 15, 30 s]
Number of Clutter (N_c)	\sim <i>Uniform</i> [0, 500]

Using these values, the scenario using UAV variant listed in Table 11 was simulated 5000 times. The results of these runs are depicted in the JMP statistical analysis software outputs shown in Figure 19. The output value quantified by this final ExtendSim UAV model is the time to find the adversary ship (T_r). This metric is critical in the SEA-21A project team’s analysis of this candidate architecture because it represents the moment in time at which the U.S. ship could employ a weapon against the adversary ship. Of note, columns one through five in Figure 19 correspond to UAVs 1–5, respectively.

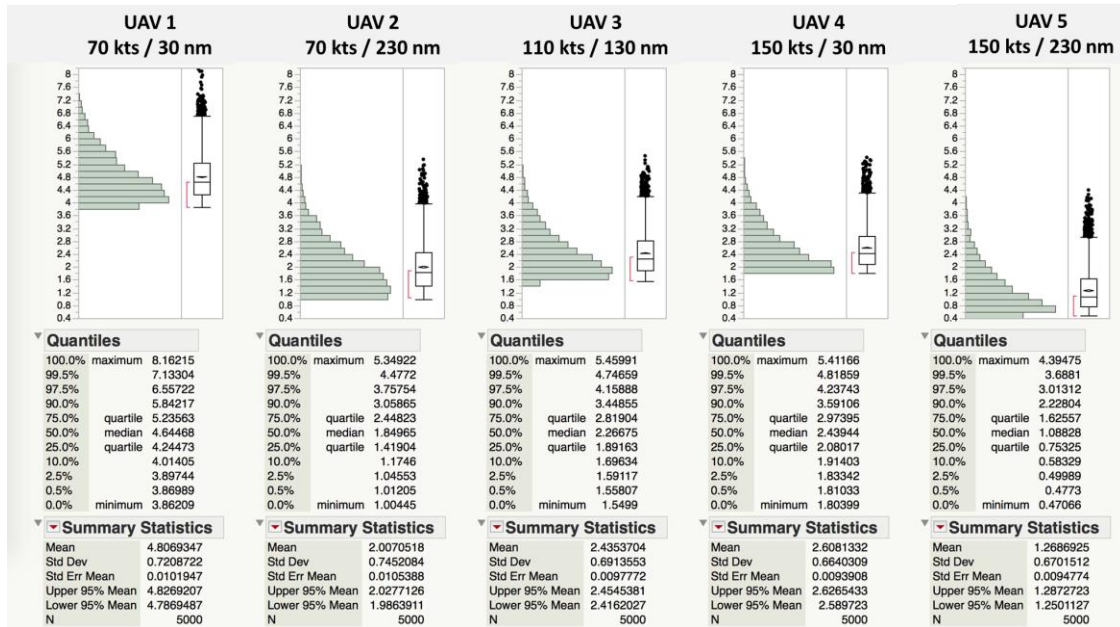

Figure 19: Single UAV Final Model Results

While it came as no surprise to the project team, the data presented in Figure 19 clearly shows that as a UAV’s speed and/or sensor radius increases, the mean time to detect the adversary ship (T_r) decreases. This output, as well as the size, weight, cost, and performance attributes of the five UAV configuration to be covered in subsequent chapters, will help to shape and ultimately define the SEA-21A project team’s UAV candidate architecture.

3. Microsoft Excel

As part of the modeling effort, the SEA-21A project team also needed to explore various numerical representations of a notional search scenario. While a simulated virtual environment is unnecessary to produce the raw data needed for an initial analysis, a spreadsheet application, such as Microsoft Excel, would serve as a sufficient tool to model and capture some raw search data.

Microsoft Excel is a spreadsheet program that includes all of the necessary features for modeling. It uses grids of cells structured in numbered rows and letter-named columns to organize and manipulate data to aid in its analysis. For the SEA-21A project team’s

study, Excel was used to model possible search performance based on several parameters. As a number of parameters are capable of being adjusted, this makes the basic search problem multi-dimensional. This can be easily analyzed using Excel’s “What-If Analysis” tool. Using this tool, the project team was able to analyze several different parameters during its initial modeling efforts. The output data shown in Figure 20 represents the time taken to achieve a 90% P_d given an increasing number of searchers. The red shaded cells indicate that the 90% P_d threshold has been met.

Figure 20. Example Microsoft Excel “What-If Analysis” Output

a. Modeling the Prepositioned Network Candidate Architecture in Microsoft Excel

As mentioned in the previous section, Microsoft Excel can be used as a modeling tool to quickly analyze scenarios that are represented numerically. In evaluating the search performance of a notional prepositioned sensor network (a potential candidate architecture for the SEA-21A project team), Excel can be used to model a worst-case scenario of a randomly moving target in a stationary sensor field. Since the Excel model consists of several independent input variables with each affecting the architecture’s performance in its own way, the model quickly becomes a multi-dimensional problem that is handled well using Excel’s “What-If Analysis” tool.

The SEA-21A project team transitioned from searching for a relatively stationary target using a moving UAV to a stationary prepositioned network (PPN) searching for a moving target. For the purposes of modeling the PPN and accounting for surface clutter, the project team assumed that the stationary PPN is capable of accurately discriminating

surface targets from neutral vessels using advanced acoustic signal processing and classification algorithms. The PPN detection scenario was modeled in Excel using the following equation for the probability of detection using a random search in a stationary field containing a moving target as proposed by Alan R. Washburn of the Naval Postgraduate School (Washburn 2002):

$$F(t) = \left(\frac{AB}{AT} \right) + \left(1 - e^{-\frac{UWt}{AT}} \right) \left(1 - \frac{AB}{AT} \right)$$

where AB is area of sensor, AT is area of operations, U is the target speed, W is search width and t is time. This equation serves as a basic model for the P_d of a possible PPN architecture, as the search area for the network can be estimated by the summation of the entire area of its coverage. This is of particular interest as communications links between the sensors can also function as relay stations for commanders at sea, where near instantaneous communications can be achieved if the vessel is within communications range of the network. Washburn's equation was used to model a notional PPN in Excel using the mission profile obtained from the baseline scenario. The inputs for the equation are shown in Table 13.

Table 13. Prepositioned Network Inputs for Excel Model

Area of Sensor (AB)	12 nm ²
Area of Operations (AT)	676 nm ²
Target Speed (U)	8 kts
Search Width (W)	4 nm

A sensitivity analysis was then performed to obtain the optimal number of deployed sensors necessary to meet a minimum probability of detection within a specified time threshold. These results are summarized in Table 14 and depict, for example, that in order to achieve a 98 percent P_d in five minutes using input parameters of Table 13, 55 sensors are required in the AOU.

Table 14. PPN Sensitivity Analysis (Number of Network Sensors Required)

Time (min)	Probability of Detection (%)													
	85	90	91	92	93	94	95	96	97	98	99	99.5	99.9	100
1	47	50	51	52	52	53	53	54	54	55	56	56	56	56
2	47	50	51	51	52	53	53	54	54	55	56	56	56	56
3	47	50	50	51	52	52	53	54	54	55	56	56	56	56
4	46	50	50	51	51	52	53	53	54	55	55	56	56	56
5	46	49	50	51	51	52	53	53	54	55	55	56	56	56
6	45	49	50	50	51	52	52	53	54	55	55	56	56	56
7	45	49	49	50	51	52	52	53	54	55	55	56	56	56
8	45	48	49	50	51	51	52	53	54	55	55	56	56	56
9	44	48	49	49	50	51	52	53	54	54	55	56	56	56
10	44	48	48	49	50	51	52	53	53	54	55	56	56	56
11	43	47	48	49	50	51	52	52	53	54	55	56	56	56
12	43	47	48	49	49	50	51	52	53	54	55	56	56	56
13	42	46	47	48	49	50	51	52	53	54	55	56	56	56
14	42	46	47	48	49	50	51	52	53	54	55	56	56	56
15	41	46	47	48	49	50	51	52	53	54	55	56	56	56
16	41	45	46	47	48	49	50	51	53	54	55	56	56	56
17	41	45	46	47	48	49	50	51	52	54	55	56	56	56
18	40	45	46	47	48	49	50	51	52	53	55	55	56	56
19	40	44	45	46	47	48	50	51	52	53	55	55	56	56
20	39	44	45	46	47	48	49	51	52	53	55	55	56	56
21	39	43	44	45	47	48	49	50	52	53	55	55	56	56
22	38	43	44	45	46	47	49	50	51	53	55	55	56	56
23	38	43	44	45	46	47	48	50	51	53	54	55	56	56
24	37	42	43	44	46	47	48	50	51	53	54	55	56	56
25	37	42	43	44	45	46	48	49	51	52	54	55	56	56
26	36	41	42	44	45	46	48	49	51	52	54	55	56	56
27	36	41	42	43	44	46	47	49	50	52	54	55	56	56
28	35	40	42	43	44	45	47	48	50	52	54	55	56	56
29	35	40	41	42	44	45	47	48	50	52	54	55	56	56
30	35	40	41	42	43	45	46	48	50	52	54	55	56	56

E. REVISED BASELINE SCENARIO FOR EXCEL AND EXTENDSIM MODELING EFFORTS

1. Revised Scenario

In a notional 2025 baseline scenario, U.S.-China tensions over Chinese expansionism in the South China Sea have boiled over and the two nations are on the brink of war. In response, the PLAN deploys a *Luyang*-class cruiser from the Yuling naval base on a patrol in the southern region of the South China Sea. The objective of this deployment is to reassert the PRC’s naval power in the region and demonstrate their willingness to act on behalf of its national interests.

In response, the U.S. Navy deploys a nearby hunter-killer SAG as part of its newly adopted “Distributed Lethality” concept on a search-and-destroy mission against the *Luyang* cruiser. Supporting the SAG’s surface search is an organic OTHT UAV that the SAG’s lead ship deploys once within range of the *Luyang*’s pre-determined AOU and outside the minimum standoff from the *Luyang*’s last known position. All ships in the U.S. SAG are armed with OTH-capable anti-ship missiles possessing a nominal range of 500 nm and will maintain an equal amount of standoff range from the AOU. This standoff range is predicated upon the adversary’s estimated anti-ship missile maximum engagement range of 200 nm and an additional buffer of 100 nm to mitigate the possibility that the adversary ship is positioned at the nearest point to the SAG in the AOU. Using an estimated transit speed of 100 kts for the OTHT UAV platform to transit to and from the AOU (i.e., six hours of transit time), a conservative threshold of eight hours for the UAV’s on-station time was established. This amounts to a total of 14 hours of required UAV flight time and is consistent with the performance of similar UAVs described in Appendix C. The revised baseline scenario’s parameters are summarized in Table 15.

Table 15. Revised Scenario Baseline Parameters

SAG Standoff Distance from <i>Luyang</i>	300 nm
Initial size of <i>Luyang</i> AOU	26 x 26 nm (676 nm ²)
OTHT UAV On-Station Time Threshold	8 hours
Neutral Shipping Traffic Density	~ 18 Ships in AOU
USN and PLAN Scenario Composition	2 x <i>Arleigh Burke</i> DDG, 1 x <i>Zumwalt</i> DD 1 x <i>Luyang</i> CG

The neutral shipping traffic density listed in Table 15 was determined using a present-day, random time assessment of shipping vessels in the vicinity of the main northeast-southwest running shipping lane that passes to the northwest of Natuna Besar enroute to the Strait of Malacca. A visual depiction of this shipping lane and the notionally Chinese-blockaded island of Natuna Besar in relation to the U.S. SAG and the PLAN *Luyang* CG is shown in Figure 21.

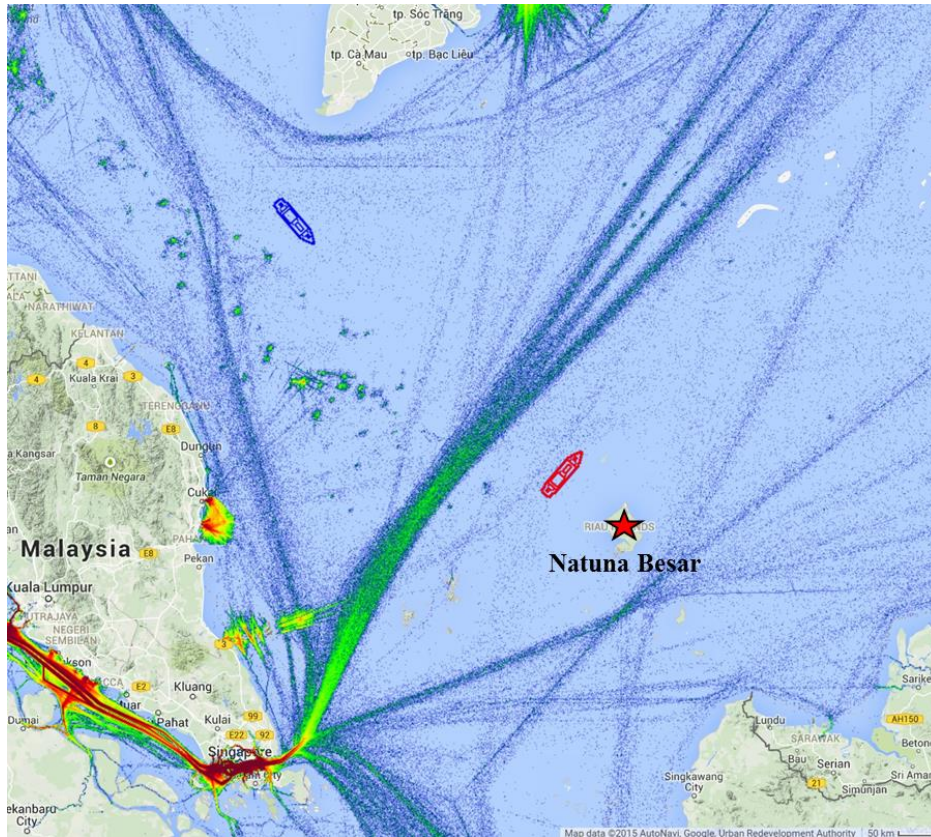

Figure 21. Revised Baseline Scenario with Maritime Traffic Density (from Marine Traffic 2015)

F. SUMMARY OF MODELING AND SIMULATION EFFORTS

The results gleaned from the SEA-21A project team’s modeling and simulation efforts using EADSIM, ExtendSim, and Microsoft Excel indicate that a comparative analysis (Chapter VII) and a cost effectiveness assessment (Chapter VIII) will assist the team in defining the optimal candidate architecture.

It is clear from the results presented in this chapter that the time to detect an adversary surface ship for the UAV architecture is primarily based on its airspeed and search width. For the PPN architecture, it is successful at detecting a target with almost perfect accuracy and does so in significantly less time than its UAV counterpart because it is already on-station at the designated AOU. However, the PPN architecture’s greatest weaknesses (as will be addressed in the two chapters that follow) lie in its size (required number of nodes), adaptability, and required maintenance.

While timely detection and classification of a target is critical, the SoS employed to do so is expected to be effective in both performance and cost. The trade analysis conducted by the SEA-21A in the next two chapters describes this connection with the project team's modeling efforts in significant detail.

THIS PAGE INTENTIONALLY LEFT BLANK

VII. ANALYSIS OF ALTERNATIVES

As this study seeks to close the current capability gap that exists with U.S. Navy surface-on-surface OTHT, the SEA-21A project team must fully grasp the concept of detecting a threat well beyond the radar horizon and organically executing every step of the F2T2EA kill chain. This, however, must be accomplished in a cost effective manner amidst ever-shrinking defense budgets and future force structures. The project team sought to identify cost effective ways to facilitate organic U.S. surface force OTHT using a comprehensive sensitivity analysis that evaluates sensor-shooter performance using a variety of modeling and simulation tools. This chapter serves to highlight the viability of the SEA-21A project team's candidate architectures.

A. OBJECTIVE

In the design process preliminary criteria and constraints were determined to guide alternative generation (Blanchard and Fabrycky 2010). The criteria and constraints were obtained in the early stages of problem development and effectiveness requirements were generated through stakeholder assessment. With the project team's stakeholder assessment complete (see Chapter II), design requirements were formulated to help better define the analysis generation approach (Buede 2009). An AoA allows for a quantitative comparison of proposed architectures and aids in determining the optimal design recommendation given the constraints and requirements of the system.

The SEA-21A project team arrived at this step of the SE process model by defining the problem through an in-depth stakeholder analysis that helped determine the requirements and various functionalities that must exist within the SoS to accomplish the given task. With the candidate design architectures introduced in the previous chapter, two methods were utilized to help determine the importance of several aspects of the various designs – pairwise comparison and value curves. By utilizing these two methodologies in conjunction with a design of experiments (DOE) and a cost analysis, the project team was able to make an informed SoS design recommendation that meets the needs of its stakeholders.

The analysis approach includes the ground rules necessary to ensure viable alternatives are produced. The goal of our analysis process stems from the central tenet of achieving long-range over the horizon targeting for the stakeholder. The chosen alternatives will need to find, fix, track, engage, and assess targets from distances greater than 500 nm. Two solution sets that create a two-pronged alternative grouping will accomplish the goal of achieving an alternative. One alternative set will include the best combination of search systems and the other set will include weapons engagement solutions.

B. ALTERNATIVE ARCHITECTURES CONSIDERED

Over the course of numerous group discussions and back-of-the-envelope analyses, the SEA-21A project team narrowed the list of candidate architectures down to two alternatives. These two alternatives are broad system representatives, with the project team's analyses exploring different variants of these two representative architectures.

1. Alternative 1 – UAV Architecture Description

The use of an UAV as the foundation for a representative alternative architecture allows for the OTHT SoS to be both adaptable and flexible amidst an evolving mission with moving targets. Numerous current UAV platforms were considered as baseline representatives for capability and costing data in addition to those still under development in various stages of design and testing. One promising example UAV system is the Tactically Exploited Reconnaissance Node (TERN) currently under development by the Defense Advanced Research Projects Agency (DARPA). The TERN system is based on the utilization of a parent ship as launch and recovery bases for medium-altitude long-endurance (MALE) unmanned aircraft (Patt 2014). This mode of operation will overcome the limited reach of land-based unmanned system surveillance by allowing for the launch and recovery bases (i.e., U.S. surface combatants) to be deployed across the open seas. In addition, by adopting a common standard for both the air and sea platforms, this will facilitate sharing of assets across different ships and thus promoting interoperability.

2. Alternative 2 – Pre-positioned Network Architecture Description

The use of a PPN as a representative alternative allows for evaluating new technologies that are in various test stages to be considered while also exploring a vastly different, and relatively unconventional, kind of candidate architecture. Such representative systems that would be integrated into PPN sensor fields are likely to be deployed prior to the onset of a conflict and have little ability to be repositioned if there are multiple, greatly separated areas of interest. Representative PPN systems that were considered by the SEA-21A project team include the National Oceanic and Atmospheric Association's (NOAA) Deep Sea and Reporting Tsunami (DART) buoy, the U.S. Navy's Seaweb, and Liquid Robotics' Wave Glider. These representative systems and their likely incorporation into the PPN candidate architecture are discussed in further significant detail in Chapter VIII (Cost Estimation).

C. ANALYSIS METHODOLOGY AND RESULTS

1. Pairwise Comparisons

The first step in performing a tradeoff analysis is to determine the various candidates for consideration. Once identified, it is imperative that the candidates are compared to one another using the same set of criteria where one system can be substituted for another within the overall SoS construct.

Key Performance Parameters (KPPs) are inherent to a specific system design and dictate the necessary metrics to which the system or SoS is to be designed and operated. Not all KPPs are COIs in the sense that they are critical to mission completeness, yet some of the KPPs are critical in the comparison of the candidate architectures and their systems to ensure that the overall SoS requirements are met. KPPs that were utilized in the AoA include:

- Deployability – the ability to redistribute the SoS or its subsystems to or within a given area;
- Performance – the efficiency of the SoS or subsystems to complete the mission;

- Mobility – the ability of the SoS or its subsystems to move;
- Adaptability – the ability for the SoS or subsystems to adjust or maneuver in response to evolving tasking;
- Vulnerability – the ability of a system to withstand outside interference. This encompassing term includes such things as detectability, stealth, resistance to cyberattack, etc.;
- Compatibility – two or more components of the SoS (i.e., subsystems) capable of mutually operating or cooperating without interference. This also includes the ability to upgrade the SoS or its subsystems from within; and
- Interoperability – the ability of the SoS or its subsystems to provide or accept services from another system or entity and to use these services to effectively operate with one another.

Once the KPPs for comparing the candidate SoS architectures were identified, they were ranked against one another based upon the mission needs of the stakeholders. The SEA-21A project team performed an analysis of these needs by utilizing a scaled value process (i.e., pairwise comparison) that quantifies the importance of specific KPPs and allows them to be compared objectively. Table 16 depicts a representative ranking schema for the aforementioned KPPs used by the project team. Pairwise comparisons are performed in order to determine which element dominates the other. These results can then be expressed as integers based on the resulting values in the table. For example, if element A dominates element B, then the whole number integer is entered in row A, column B, and the reciprocal (fraction) is entered in row B, column A (Project Performance International 2011). A weighting to the left of “1” favors the metric on the left, while a weighting to the right of “1” favors the metric on the right. Additionally, a weighting of “1” for any of the comparisons implies that both are equally important when compared to each other.

Table 16. Example INCOSE Pairwise Comparison Matrix

KPPs																		
Deployability	9	8	7	6	5	4	3	2	1	2	3	4	5	6	7	8	9	Performance
Deployability	9	8	7	6	5	4	3	2	1	2	3	4	5	6	7	8	9	Mobility
Deployability	9	8	7	6	5	4	3	2	1	2	3	4	5	6	7	8	9	Adaptability
Deployability	9	8	7	6	5	4	3	2	1	2	3	4	5	6	7	8	9	Vulnerability
Deployability	9	8	7	6	5	4	3	2	1	2	3	4	5	6	7	8	9	Compatibility
Deployability	9	8	7	6	5	4	3	2	1	2	3	4	5	6	7	8	9	Interoperability
Performance	9	8	7	6	5	4	3	2	1	2	3	4	5	6	7	8	9	Mobility
Performance	9	8	7	6	5	4	3	2	1	2	3	4	5	6	7	8	9	Adaptability
Performance	9	8	7	6	5	4	3	2	1	2	3	4	5	6	7	8	9	Vulnerability
Performance	9	8	7	6	5	4	3	2	1	2	3	4	5	6	7	8	9	Compatibility
Performance	9	8	7	6	5	4	3	2	1	2	3	4	5	6	7	8	9	Interoperability
Mobility	9	8	7	6	5	4	3	2	1	2	3	4	5	6	7	8	9	Adaptability
Mobility	9	8	7	6	5	4	3	2	1	2	3	4	5	6	7	8	9	Vulnerability
Mobility	9	8	7	6	5	4	3	2	1	2	3	4	5	6	7	8	9	Compatibility
Mobility	9	8	7	6	5	4	3	2	1	2	3	4	5	6	7	8	9	Interoperability
Adaptability	9	8	7	6	5	4	3	2	1	2	3	4	5	6	7	8	9	Vulnerability
Adaptability	9	8	7	6	5	4	3	2	1	2	3	4	5	6	7	8	9	Compatibility
Adaptability	9	8	7	6	5	4	3	2	1	2	3	4	5	6	7	8	9	Interoperability
Vulnerability	9	8	7	6	5	4	3	2	1	2	3	4	5	6	7	8	9	Compatibility
Vulnerability	9	8	7	6	5	4	3	2	1	2	3	4	5	6	7	8	9	Interoperability
Compatibility	9	8	7	6	5	4	3	2	1	2	3	4	5	6	7	8	9	Interoperability

Once the KPPs were compared to one another and their relative importance properly quantified using the matrix depicted in Table 16, the next step was to determine the applicable weights for each. These weights were determined using the two-step process outlined below (to include a sample calculation for each step using the KPP “deployability”) and are summarized in Table 17.

1. Sum-product row: sum each column, take the reciprocal:

$$1/(1.00+3.00+2.00+4.00+0.50+0.50+0.50) = 0.087$$

2. Determine weights: calculate the sum product of the sum-product and criteria rows, and divide by the number of criteria present:

$$[(1.00 \times 0.087) + (0.33 \times 0.308) + \dots + (2.00 \times 0.091)]/8 = 0.13$$

Table 17. Calculated KPP Comparison Weightings

	Criteria	Deployability	Performance	Mobility	Adaptability	Vulnerability	Compatibility	Interoperability	Weights
Criteria		1	2	3	5	6	7	8	
Deployability	1	1.00	0.33	0.50	0.25	2.00	4.00	2.00	0.130
Performance	2	3.00	1.00	2.00	3.00	2.00	3.00	4.00	0.276
Mobility	3	2.00	0.50	1.00	0.25	4.00	1.00	0.50	0.123
Adaptability	5	4.00	0.33	4.00	1.00	3.00	1.00	1.00	0.192
Vulnerability	6	0.50	0.50	0.25	0.33	1.00	2.00	0.50	0.078
Compatibility	7	0.50	0.33	1.00	1.00	0.50	1.00	2.00	0.097
Interoperability	8	0.50	0.25	2.00	1.00	2.00	0.50	1.00	0.103
Sum-Product Row		0.087	0.308	0.093	0.146	0.069	0.080	0.091	

A graphical depiction of the calculated KPP weights summarized in Table 17 is shown in Figure 22 and represents a high-level interpretation of the stakeholder’s mission needs while also capturing which of the KPPs are the most dominant.

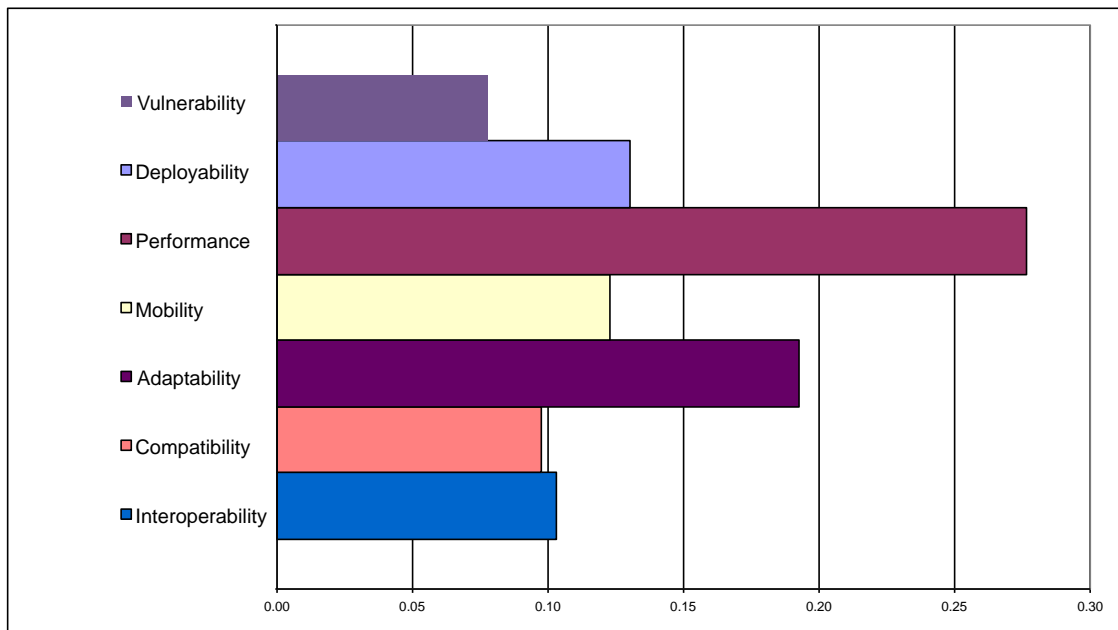

Figure 22. Graphical Depiction of KPP Comparison Weights

From the results presented in Figure 22, it was clear that both performance and adaptability were the most important in satisfying the needs of the project's stakeholders. While the lowest three identified KPPs account for less than 25 percent of the total weight, this initial analysis investigates the most important KPPs to identify key insights. A more detailed investigation using the full complement and/or additional measures is left for future study. As the project team's AoA efforts progressed, performance and adaptability would become critical in identifying the best candidate architecture through the use of a DOE for the project team's recommended design solution.

2. Value Curves

After determining the pairwise comparison weights, the SEA-21A project team used the results to compare the relative effectiveness of candidate systems (for example, potential UAVs and PPNs) using a standardized set of value curves. Value curves are a part of a multi-attribute decision making (MADM) value analysis, which considers the aggregate effectiveness of different alternatives over a ranked set of objectives or preferences from multiple stakeholders. Having ranked the project team's top seven KPPs in the previous section, the next step is to assign the relative value of improving from the minimum acceptable threshold to the design objective using a value curve (Buede, 2009). The curve is typically normalized on the ordinate (Y-axis) in terms of the relative value that particular KPP provides, while the raw data for each candidate subsystem determines its position on the abscissa (X-axis). A curve is then derived based on a careful analysis of each particular KPP value for a specified range of raw data values. The four types of graphs that are typically used to perform such comparisons include a linear slope (both positive and negative), an exponential decay or growth, and an S-curve. The SEA-21A project team determined the range of KPP values based on stakeholder inputs, standardized metrics, accepted heuristics, and operational experiences. Once the value curves were created with the proper metrics determined, each alternative was plotted on their respective curves to obtain a value that will be used to compare each alternative to one another.

In comparing and contrasting the two primary SEA-21A candidate architectures, a UAV has the ability to quickly adapt to a change in a mission, whereas a PPN is restricted

to the area in which it was deployed. Conversely, a PPN is likely to outperform a UAV in time to detect a target due to its ability to continuously monitor a given AOU. Due to situations such as these where candidate architectures perform differently across a varying set of KPPs, the use of a MADM model is justified. The primary steps involved in such a model include determining

- a value hierarchy with systems functions, objectives, and KPPs;
- value curves using maximum and minimum values;
- a weighting system (not all measures are equal);
- raw scores for each alternative and value; and
- a single overall value for each alternative by aggregating measure values.

Taking into account the above methodology, MADM value curves for the SEA-21A candidate architectures were created based on the top four KPPs (listed in descending order) in terms of importance to stakeholders as they represent 75 percent of the total KPP weights:

- performance (time to detect an adversary ship);
- adaptability;
- deployability; and
- mobility.

Through careful stakeholder analysis and adherence to the MADM process steps outlined above, the SEA-21A project team constructed the value curves depicted in Figures 23 through 26.

a. Performance Value

The “performance” parameter was quantified as the time to detect an adversary target in the designated search area for each configuration of the UAV and PPN architectures. The modeling approaches for deriving the performance input for the two architectures are detailed in Chapter VI and are reiterated below:

- UAV – The mean time to detect an adversary target in the search area over 5,000 simulation runs for each configuration; and

- PPN – The expected time (t) to achieve a 95% P_d for differing levels of coverage using Washburn’s equation for probability of detection using a random search in a stationary field containing a moving target.

The value curve for performance places the most value on systems that can localize a target within the first two or three hours of an initiated search. This benchmark is based on the modelled scenario, which places the boundary of the adversary ship AOU approximately 300 nm distant from the U.S. SAG. At this distance, the adversary surface combatant could conceivably close to within weapon employment range (about 250 nm) in two to three hours. After the first few hours, the effectiveness of the system decreases in a mostly linear fashion, then leveling off after approximately 10 hours, or the time it would take adversary or U.S. forces to close to within U.S. weapon engagement range (~ 60 nm) using the current surface-to-surface anti-ship weapon system (RGM-84 Harpoon).

The data from the SEA-21A modeling and simulation efforts were used to generate points for different alternatives pertaining to both the UAV and PPN systems on the performance value curve. Table 18 depicts the five representative system configurations (as previously summarized in Table 11) that were investigated by the project team for the UAV candidate architecture in order to cover the spectrum of speed/range combinations.

Table 18. Representative UAV System Configuration Selection

UAV Speed (kts)	Sensor Range (nm)				
	30	50	130	150	230
70	UAV1				UAV2
90					
110			UAV3		
130					
150	UAV4				UAV5

In a similar fashion, the representative PPN candidate architectures were chosen using a broad range of coverage options to examine the effect on performance (time to

detect an adversary surface ship) and, eventually, cost. The PPN configurations were varied based upon the percentage of the search area occupied by its stationary sensor coverage. These three representative configurations were:

- PPN1 – 95% coverage (53 sensors);
- PPN2 – 66% coverage (37 sensors); and
- PPN3 – 33% coverage (19 sensors).

The three configurations above were chosen by the SEA-21A project team in order to provide a reasonable estimate of the range of stationary sensor coverage configurations available to meet the 95% P_d threshold of within three hours. With both the UAV and PPN performance values established, they were then plotted on the performance value curve depicted in Figure 23 and serve as the basis for comparing the representative systems of the two candidate architectures.

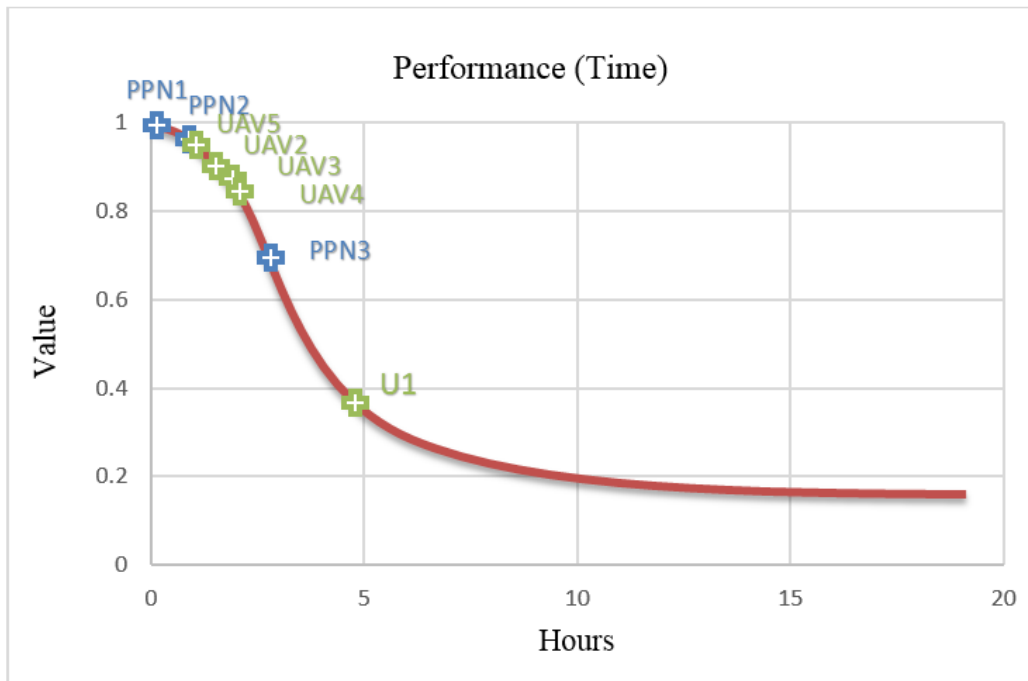

Figure 23. Performance Value Curve

The performance value curve input values for each configuration are discussed later in this section and summarized in Table 20.

b. Adaptability Value

The ability of a system to adapt to changing mission requirements can be measured a number of ways. For example, a change in mission requirements or tasking could include a change or update to a given AOU. While the scenario used in the project team’s modeling and simulation efforts considered a predetermined AOU for the adversary threat, a system that can adapt to an emerging threat or change in location (i.e., a different AOU) provides additional benefit. The value curve for adaptability shown in Figure 24 considers the time it would take for the SoS to shift its focus to a new AOU and begin its search.

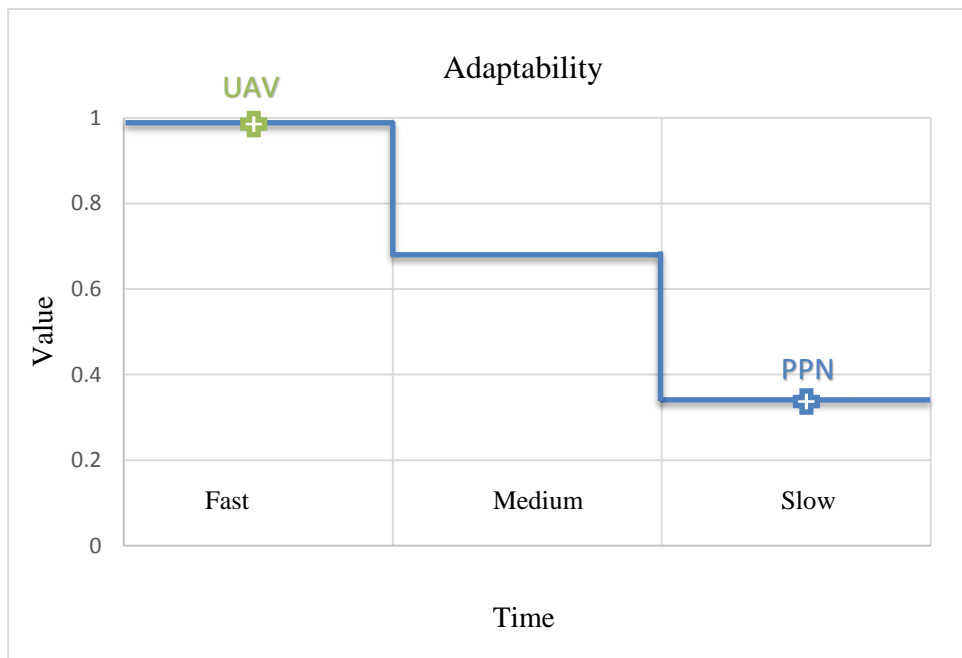

Figure 24. Adaptability Value Curve

Just as with the performance value curve, the ability to adapt to a new mission or focus area is most effective in the first few hours. For the sake of simplicity, this new AOU could be identified to be located, e.g., approximately 300 nm from the original search area. The ability of a system to adapt to this emergent mission area is considered “slow” if it is expected to take more than 10 hours to shift focus. Classification as “medium” would result from the ability of the system to shift focus between three and 10 hours, and a “fast” classification if the system is expected to be able to adapt in less than three hours.

c. Mobility Value

While adaptability considers the time taken for the system to accommodate a new AOU, mobility considers the ability of the system to physically move from one location to another. This measure is intended to consider the speed at which the system can move, irrespective of the mission scenario. The mobility value curve depicted in Figure 25 assigns greater value to systems that can reposition their sensors or sensor platforms more quickly.

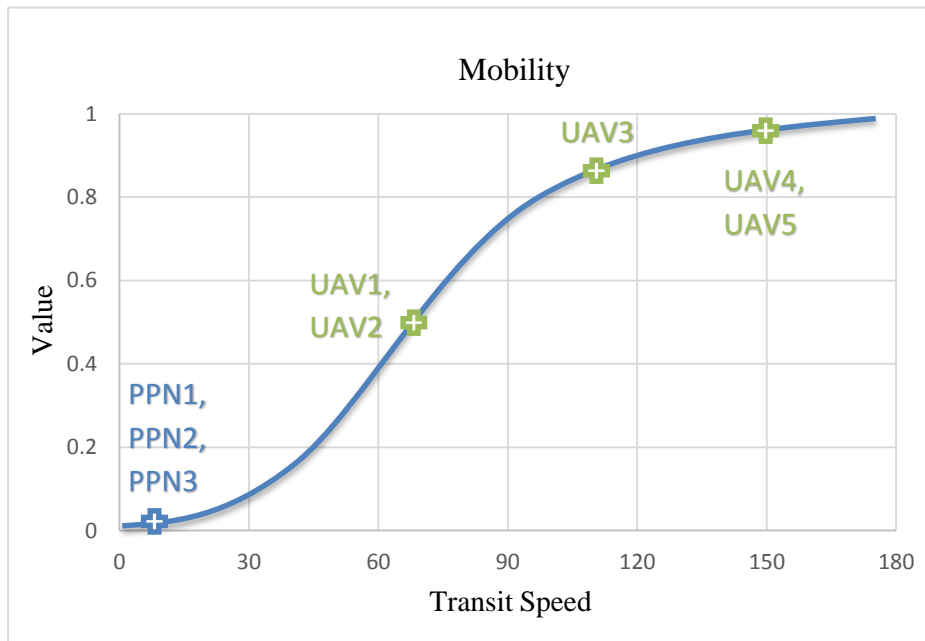

Figure 25. Mobility Value Curve

Systems that move more slowly than the U.S. surface combatants have the least amount of value. An inflection point in the mobility value curve is found at approximately 25 knots, and increasing speed exhibits a mostly linear advantage until about 100 knots. At this point, the ability of the SoS to cover the 300 nm mission scenario distance to the adversary AOU in less than three hours results in the most utility.

d. Deployability Value

Deployability refers to the ease with which the system can be staged and employed in the operating area, which may contain or be adjacent to a mission AOU. This measure considers logistics, such as deck space and the system's footprint, on U.S. surface

combatants in addition to likely manpower requirements and additional platforms required to deploy and/or maintain the SoS and its subsystems (e.g., UAV, buoys, sensors, and subsystem components). Figure 26 depicts the deployability value curve and the relative scores for the two primary SEA-21A candidate architectures.

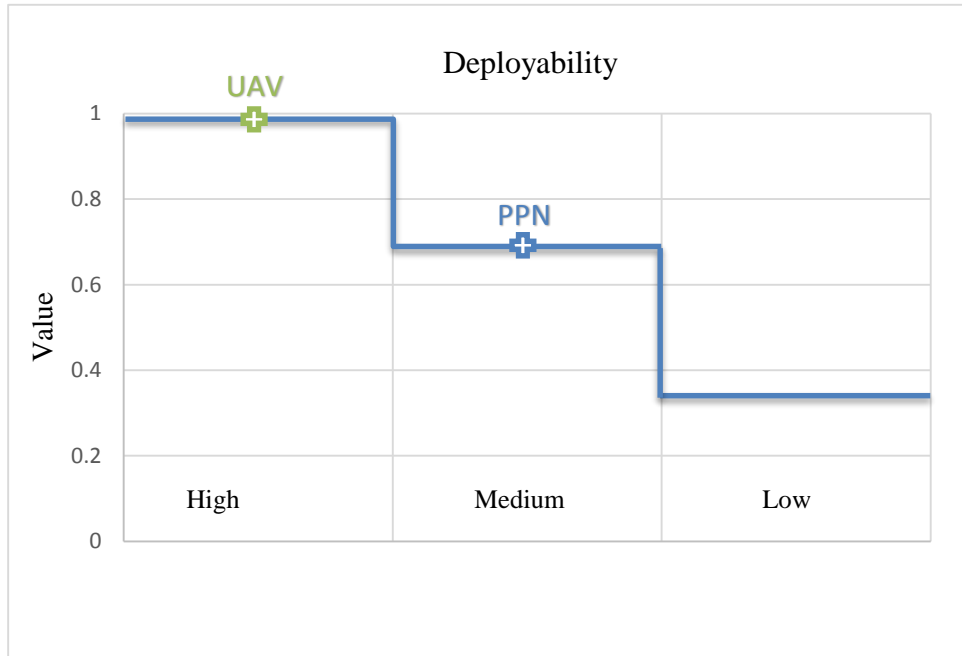

Figure 26. Deployability Value Curve

For this measure, an architecture with “low” deployability requires not only additional platforms, assets, and manpower that may not already be in theater, but also a preparation time of approximately two to three days in order to organize for deployment. Systems with “medium” deployability are assumed to be ready at relatively short notice, but still require additional assets in order to deploy. Finally, systems considered to have “high” deployability are ready to use at a moment’s notice or within hours of initial notification. Based upon this deployability classification schema, systems that are organic to U.S. surface combatants will possess “high” deployability, while systems requiring other ships or aircraft to deploy components or sensors will be considered to possess “medium” to “low” deployability.

3. Value Scores and Decision Matrix

The candidate architecture’s raw value scores as determined and quantified by the SEA-21A project team are summarized in Table 19. By comparing these scores along with associated variations in range and classification, the SEA-21A project team can better quantify the performance of the candidate architectures before applying swing weights to each in order to determine which architecture(s) best suit the stakeholders’ needs.

Table 19. Raw Value Scores for PPN and UAV Candidate Architectures

Evaluation Measure	PPN1	PPN2	PPN3	UAV1	UAV2	UAV3	UAV4	UAV5
Performance	0.99	0.98	0.69	0.38	0.89	0.86	0.84	0.97
Adaptability	0.33	0.33	0.33	0.99	0.99	0.99	0.99	0.99
Mobility	0.04	0.04	0.04	0.51	0.51	0.88	0.96	0.96
Deployability	0.66	0.66	0.66	0.99	0.99	0.99	0.99	0.99

A comparison of the input values for each sample configuration were compared across the range of inputs, yielding a variation in range for each measure. Accounting for the variation in range aligns (or normalizes) the ranges of input values for each measure using the following relationship (Buede 2009):

$$Variation = (max-min / (avg))$$

The input values for each configuration, resultant variations in range from the aforementioned relationship, and a qualitative ranking of the variation classifications were then assembled by the project team and are summarized in Table 20.

Table 20. Candidate Architectures’ Variation in Range and Classification

Evaluation Measure	PPN 1	PPN 2	PPN 3	UAV 1	UAV 2	UAV 3	UAV 4	UAV 5	Var in Range	Var Class
Performance (Hours)	0.02	1.0	3.0	4.8	2.0	2.4	2.6	1.3	2.23	High
Adaptability (Fast-Med-Slow)	33	33	33	99	99	99	99	99	0.89	Med
Mobility (Knots)	5	5	5	70	70	110	150	150	2.05	High
Deployability (High-Med-Low)	66	66	66	99	99	99	99	99	0.38	Low

4. Swing Weights

The SEA-21A project team elected to utilize swing weights in order to assess both the importance of each key attribute (i.e., performance, adaptability, mobility, and deployability) and its associated variation in range. Table 21 shows the assignment of swing weights to those key attributes. These values are based on the relative importance of each attribute and are displayed in the table with their associated variation classification.

Table 21. Key Attribute Swing Weight Assignment

Variation in Range	Importance		
	High	Medium	Low
High	9 Performance	6 Mobility	3
Medium	8 Adaptability	5	2
Low	7	4 Deployability	1

The assigned swing weights were then used to determine the measure weight by dividing the value for each measure by the sum of all values. These results are summarized for each attribute in Table 22.

Table 22. Summary of Key Attribute Swing Weights and Measure Weights

Evaluation Measure	Swing Weight	Measure Weight
Performance	9	0.33
Mobility	6	0.22
Adaptability	8	0.30
Deployability	4	0.15

Decision Matrix

Table 23 summarizes the input values (used on the x-axis of the value curves) and the value scores (from the y-axis of the value curves) for each of the key attributes. These

value scores were then multiplied by the weights for each evaluation measure to give a final weighted score for each alternative. To follow the example superimposed on Table 23, the Mobility input value of 150 knots (a) for UAV4 is placed on Figure 25 at the point where it intersects the value curve, yielding a score of 0.96 (b). This score is then multiplied by the measure weight (c) to produce a weighted score (d) of 0.21 for the UAV4 variant. The weighted scores for each parameter are then added up for each architecture variant and the total yields an overall effectiveness score for each.

Table 23. Candidate Architecture Decision Matrix

Input Values

Evaluation Measure	Weight	PPN1	PPN2	PPN3	UAV1	UAV2	UAV3	UAV4	UAV5
Performance (Hours)	0.33	0.02	1.0	3.0	4.8	2.0	2.4	2.6	1.3
Mobility (Knots)	0.22	5	5	5	70	70	110	150	150
Adaptability (Fast-Med-Slow)	0.30	33	33	33	99	99	99	99	99
Deployability (High-Med-Low)	0.15	66	66	66	99	99	99	99	99

Value Scores

Evaluation Measure	Weight	PPN1	PPN2	PPN3	UAV1	UAV2	UAV3	UAV4	UAV5
Performance	0.33	0.99	0.98	0.69	0.38	0.89	0.86	0.84	0.97
Mobility	0.22	0.04	0.04	0.04	0.51	0.51	0.88	0.96	0.96
Adaptability	0.30	0.33	0.33	0.33	0.99	0.99	0.99	0.99	0.99
Deployability	0.15	0.66	0.66	0.66	0.99	0.99	0.99	0.99	0.99

Weighted Values

Evaluation measure	Weight	PPN1	PPN2	PPN3	UAV1	UAV2	UAV3	UAV4	UAV5
Performance	0.33	0.33	0.33	0.23	0.13	0.30	0.28	0.28	0.32
Mobility	0.22	0.01	0.01	0.01	0.11	0.11	0.20	0.21	0.21
Adaptability	0.30	0.10	0.10	0.10	0.29	0.29	0.29	0.29	0.29
Deployability	0.15	0.10	0.10	0.10	0.15	0.15	0.15	0.15	0.15
Totals	1.00	0.54	0.54	0.44	0.68	0.85	0.92	0.93	0.97

The weighted scores (“Totals” row) shown in

Table 23 for each candidate architecture are presented in Figure 27 and depict the relative overall effectiveness of each configuration.

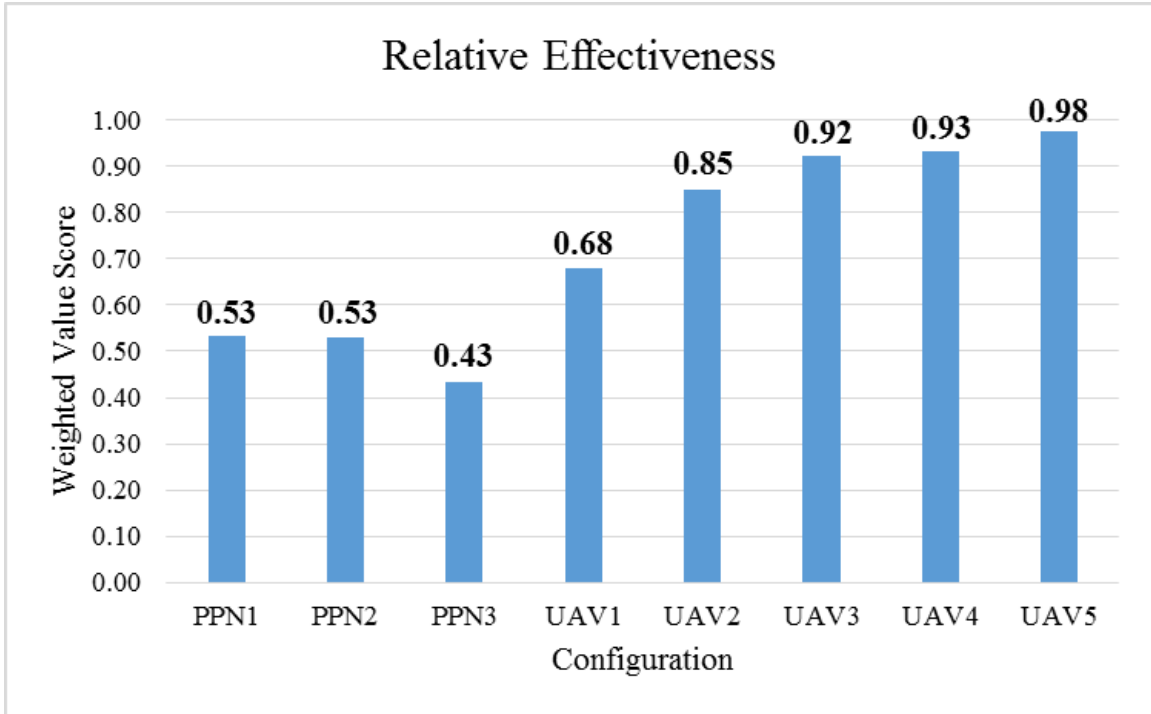

Figure 27. Candidate Architecture Relative Effectiveness

The relative effectiveness chart displayed in Figure 27 suggests that, **without considering cost effectiveness, the various configurations of the UAV architecture that were considered are all likely to be more valued than the PPN configurations**, and, therefore, best suited to meet the needs of the project’s stakeholders. The next chapter considers the respective costs of the various UAV and PPN candidate architectures so that both effectiveness and cost can together be used to determine the SEA-21A project team’s recommended design solution.

THIS PAGE INTENTIONALLY LEFT BLANK

VIII. COST ESTIMATION

A. COST ESTIMATION METHODOLOGY

In addition to the technical study that is generated during the development of a system or SoS, a cost estimation study must also take place. Cost analysis is a critical step for a military SoS, such as the one the SEA-21A project team is seeking to design. If the cost of a system is not given proper consideration, system effectiveness can be negatively impacted and the acquisition program could be cancelled. It is paramount that decision makers are not only presented with the technical specifications and performance of a system, but also the costs associated with developing, acquiring, supporting, and disposing of that system. In the case of the SEA-21A capstone project, a robust cost analysis that includes a life cycle cost estimate (LCCE) of the candidate architectures/alternatives is necessary to support the project team's ultimate SoS design recommendation.

In estimating a system's overall cost, several different methods can be utilized. The DoD acknowledges and employs five different methods in its cost analyses in the acquisition of defense systems:

- Parametric – A method employing algorithms and equations to represent the cost of a particular alternative. These algorithms and equations are called cost estimating relationships (CERs). CERs are obtained through regression and data analysis with the goal of emerging with an equation to best fit the variables in the data points (Isodori, van Schuppen, Sontag, and Krstic 1997);
- Analogy – A cost estimating technique that takes one or more currently fielded systems and uses them as a model for a future system's cost. The future system must be similar in size and capacity to the currently fielded system. The future system cost is then adjusted based on differences in length, width, weight and other dimensions (Gilmore and Valaika 1992);
- Engineering Estimate – When detailed cost data on engineering components are available, an engineering estimate is possible. Also referred

to as a “bottom-up” estimate, an engineering estimate takes figures from well-established systems and creates algebraic relationships to simulate similar future systems. The relationships make it possible to estimate the various budget segments of a SoS (Defense Acquisition University 2004);

- Extrapolation of Actual Cost – If prototypes or early models exist, then this method is available for cost analysis. The existing cost metrics on the early models of a system can be used to estimate present cost. When using this method, maintainability and reliability changes need to be considered (Department of Defense 1992); and
- Cost Factors – To determine indirect costs, such as medical, training, and base operations, cost factors are implemented. They are per capita figures applied to direct costs in order to determine the subsidiary budget (Gilmore and Valaika 1992).

The SEA-21A project team utilized a top-down cost estimation approach in evaluating the candidate SoS architectures. The team began by dividing the overall SoS’s cost into smaller, more manageable segments. In doing this, each DoD cost estimation method identified above was used in some form or another. Much of the data used for the SEA-21A project team’s cost analysis was obtained from various sources, such as the DoD Cost Estimating Guide, Jane’s Weapons Database, scholarly documents, and subject matter experts. The Defense Cost and Resource Center (DCARC) and Navy Visibility and Management of Operating and Support Costs (VAMOSOC) also provided a large library of budget data that was used to determine alternative costing figures.

1. UAV Architectures Cost Estimation Method

The process of arriving at a LCCE for the UAV candidate architectures began with the gathering of cost data on a single UAV system. Data were obtained by the SEA-21A project team on existing UAV systems widely used in the military and commercial industry. Their scope and capabilities ranged from small, man-portable systems to large, robust carrier-based unmanned aircraft. Summaries of such systems can be found in Appendix C. With the assistance of various open-source databases, a list of representative

specifications was developed by the project team. After obtaining representative systems' weight, endurance, sensor range, and speed for each UAV, the data were then subjected to a regression analysis in order to determine which variable(s) best represented the cost of existing UAVs. Once the regression data was obtained, the output equations were then validated using existing cost data for those UAV systems. With the validated estimation equations in-hand, the SEA-21A project team then used the same input metrics as in the M&S effort to generate representative LCCEs for the candidate architectures. The total life cycle cost of the potential UAV alternatives can then be determined by implementing a cost factor from historical data on existing UAVs. Using the procurement costs determined from the regression analysis, the cost factors were then used to get an overall representation of the costs associated with research, development, test, and evaluation (RDT&E), military construction (MILCON), and operations and support (O&S) based on their relative proportion. Figure 28 depicts a life-cycle cost breakdown for representative UAV systems currently in use with the DoD.

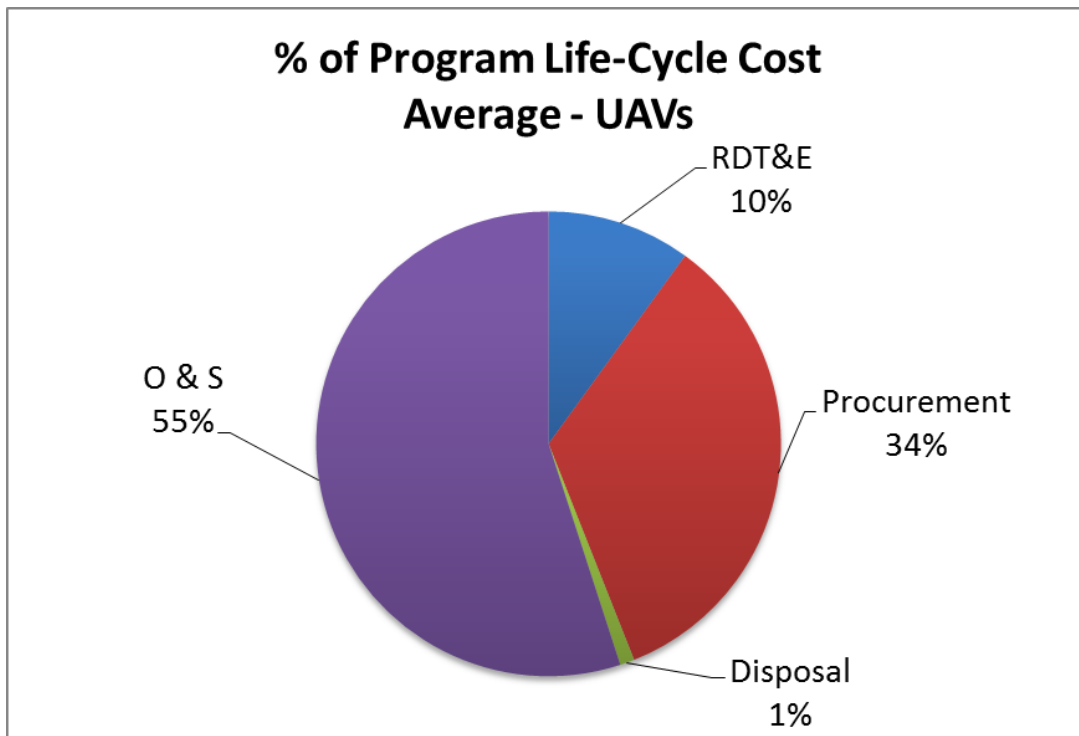

Figure 28. Breakdown of Representative UAV Systems' Life Cycle Costs

2. Pre-positioned Network Architecture Cost Estimation Method

The procedure utilized to conduct the PPN architecture cost analysis began with finding a system comparable to that of the one envisioned by the SEA-21A project team. Though such an undersea sensor network does not currently exist, similar constructs presently in use were examined in order to provide a costing reference for the project team's proposed candidate network architecture. These existing systems include NOAA's DART buoy, the U.S. Navy's Seaweb, and the Liquid Robotics' Wave Glider. The combination of specifications from these three representative systems, individually described below, are representative of the buoy/node underwater sensor capability envisioned for the project team's prepositioned undersea network candidate architecture.

a. NOAA's DART Buoy

The DART buoy system was developed by NOAA to survey wave heights in order to provide advanced detection and notification of tsunamis. Above the surface exists a GPS antenna, satellite antenna, and radio communications equipment. Below the surface are mooring lines and a tsunamimeter that is capable of sending an acoustic signal 5000m from the sea floor. More than 30 DART buoys are currently located along the arc of volcanic activity in the Pacific Ocean called the "Ring of Fire." A graphical representation of NOAA's DART buoy is shown in Figure 29.

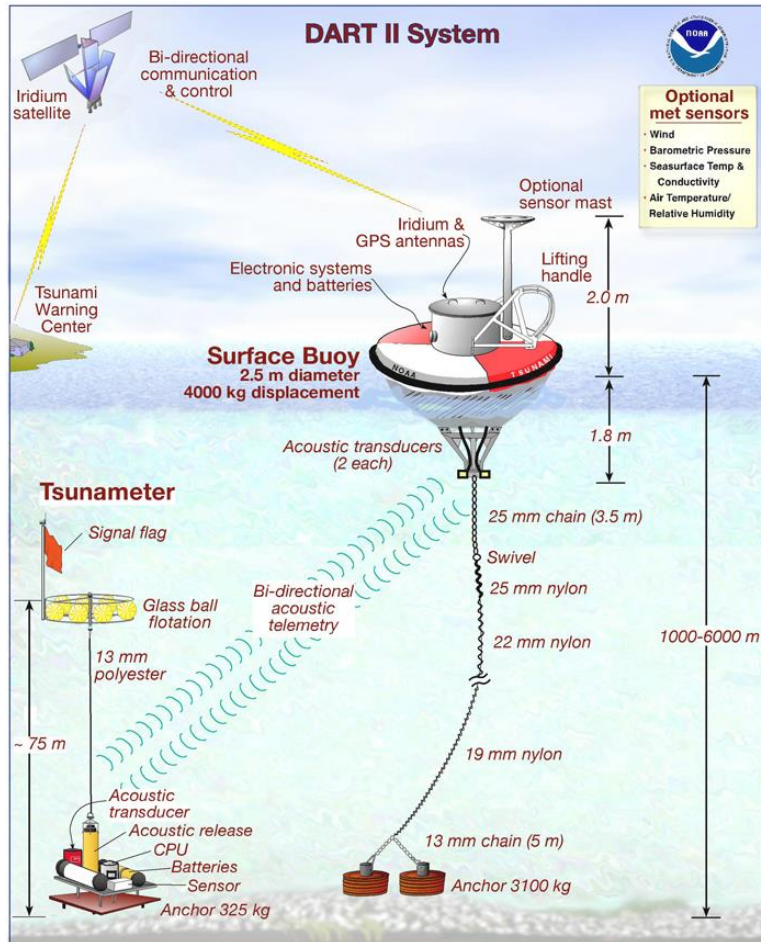

Figure 29. NOAA's DART Buoy System (from NOAA 2015)

b. U.S. Navy's Seaweb

More than 50 Seaweb network nodes have been placed in littoral regions throughout the world and consist of arrays of acoustic modems that rest on the seafloor at depths of up to 300 m (Rice and Green 2008). These modems are set to detect within a specified frequency band and, once a detection has been made, an undersea signal is sent to a gateway buoy that possesses a satellite link. Seaweb modems can be deployed via ship or aircraft and sink to the seafloor where they begin to listen. A graphical depiction of the U.S. Navy's Seaweb is shown in Figure 30.

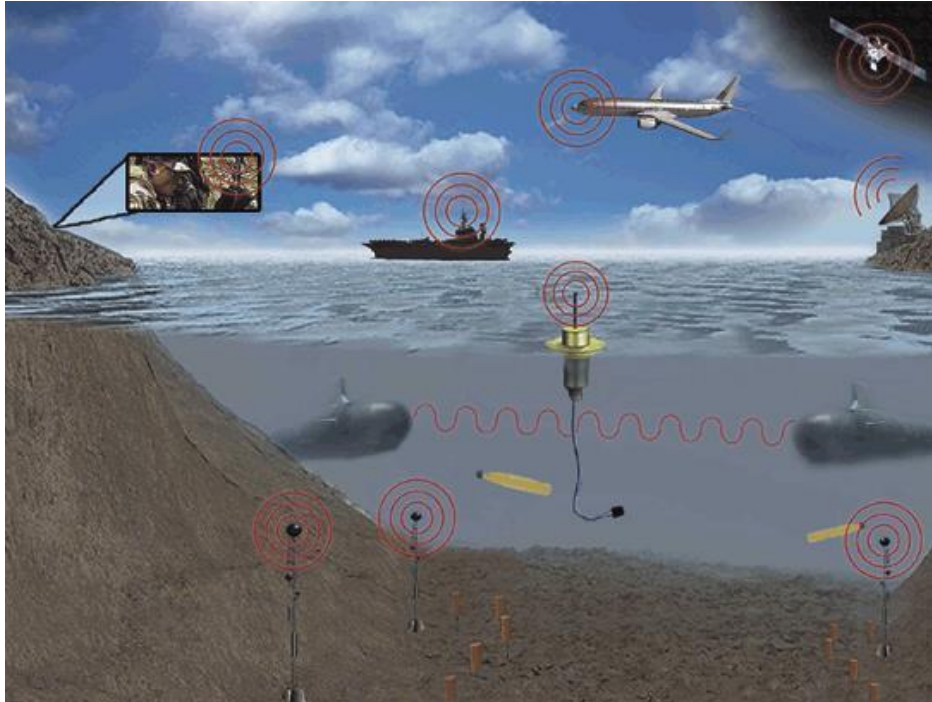

Figure 30. U.S. Navy's Seaweb Undersea Network (from Truver 2006)

The Telasonar modem integrated in Seaweb has been used by the U.S. Navy and commercial industries for over 10 years and is designed to use minimal energy for long periods of time until a contact is detected (Rice and Green 2008). The complex activities required to accomplish such acoustic communications are modelled in detailed algorithms within the modem's software.

c. Liquid Robotics' Wave Glider

The Wave Glider (as shown in Figure 31) is an unmanned sensor package capable of sustained operations in 90% of the world's oceans (Liquid Robotics 2014). With the use of wave power and solar energy, an assortment of data can be sent on a consistent basis via satellite to an operations center for interpretation and dissemination. The Wave Glider system is deployed using sea vessels special adapted for the task. However, minimal support is needed once the systems are launched, and they can be controlled both autonomously and manually. Additionally, the software utilized on Wave Gliders is capable of running systems in efficient formats in order to conserve energy and prolong the use of the system itself.



Figure 31. Liquid Robotics' Wave Glider (from AUVAC 2011)

After careful deliberation, the SEA-21A project team elected to use the Seaweb system as a reference for deriving the cost estimating data for its PPN candidate architecture. The justification for this decision included the technological maturity, cost, deployability, and manpower required to deploy, maintain, and operate the PPN systems. The DART buoy, Seaweb, and Wave Glider systems together represent a solid foundation for the project team's use of the analogy method to perform a cost estimation of the PPN candidate architecture.

With the costing data of these systems in hand, the next step was to create an analogous cost estimate in order to model an overall LCCE for the PPN. The RDT&E cost was derived from the five year NOAA Dart buoy programs research budget, while much of the procurement analysis was derived from data compiled from Seaweb, Wave Glider, and the Navy's Program Executive Office for Command, Control, Communications, Computers, and Intelligence (PEO C4I). Additionally, an operations and support costs breakdown of the PPN was achieved by using guidance from Liquid Robotics' total ownership cost models for their Wave Glider.

B. COST ESTIMATION ASSUMPTIONS

As with any cost estimation estimate, a number of assumptions must first be made before beginning such an effort. Using the representative UAV and PPN systems as the foundation for SEA-21A's cost estimation, the project team determined that the following assumptions would be made:

- Adjusting for inflation – The cost figures used for this analysis are normalized to FY15 dollar values based on the inflation indices stated in Circular A-94 issued by the Office of Management and Budget;
- Relative proportion of UAV component costs – The UAV acquisition cost was determined using the results obtained through regression analysis. However, the UAV RDT&E and O&S costs would be estimated using their respective acquisition cost and their relative proportions in accordance with the Cost Assessment and Program Evaluation guide issued by the Office of the Secretary of Defense (OSD);
- Learning curves – Learning curves take into consideration the reduction in cost seen in manufacturing subsequent units due to the experience and proficiency gained from the production of earlier units. For this cost estimation study, the following learning curves were assumed: Overall - 85% (Rodney 1995); Aerospace (UAV) – 85% (Canavan 2004); PPN – 95% (Rodney 1995);
- Life span of PPN buoys is 10 years – Acoustic buoys fall into the defense system category of “electronic systems” and this is the design life expectancy for such systems (Gilmore and Valaika 1992);
- LCCE cost is based on a total of 10 years – According to the DoD, cost estimation for the life span of small aircraft is typically 15 years. However, in the case of small, relatively lightweight UAVs, a cost comparison model that considers all SEA-21A representative systems was assumed to be 10 years;

- Alternative discount rate is zero - All SEA-21A alternative costing is based on FY15 cost rates as inflation rates will undoubtedly impact future alternatives' pricing to some degree; and
- Disposal costs not considered – Due to the lack of available data regarding the disposal costs of analogous UAV/PPN systems and architectures, the SEA-21A project team elected to neglect the impacts of disposal costs in developing LCCEs.

C. UAV ARCHITECTURE COST ESTIMATION DATA ANALYSIS

1. Procurement Costs and Cost Estimating Relationships

The SEA-21A project team’s cost modeling effort began with estimating the procurement cost of the individual system. Procurement costs include both investment costs and construction costs. Regression models can be used in conjunction with existing systems’ costing data and performance specifications (depicted in Table 24) to develop representative cost estimation models for the SEA-21A UAV-based candidate architectures.

Table 24. Existing DoD UAV Procurement Cost and Performance Data

UAV System	Procurement Cost (FY15 \$M)	Weight (lbs)	Payload Weight (lbs)	Total Weight (lbs)	Endurance (hrs)	Range (nm)	Speed (kts)
Predator	5.394	1130	450	1580	40	675	117
Gray Eagle	13.54	3197	1075	4272	25	400	167
Hummingbird	19.29	1650	2500	4150	20	1397	163
Fire Scout	9.8	2073	600	2673	8	300	115
Reaper	13.09	3695	3850	7545	27	1000	239
Neptune	0.685	60	20	80	4	40	39
T-Hawk	0.2686	17.5	2	19.5	1	6	39
Blackjack	1.05	81	39	120	16	55	90
Wasp	0.0524	0.9	0.2	1.1	1.5	2.7	35
ScanEagle	0.1029	30.9	6	36.9	24	55	80
Raven	0.0658	2	1	3	1.5	5.4	44
Shadow	3.853	186	60	246	5	59	110

Physical and performance characteristics, such as weight, endurance, range, and speed for the UAV systems listed in Table 24, were analyzed to determine which aspects

(if any) directly correlated to the cost of the systems themselves. Regression analysis using one parameter at a time revealed that the single most influential cost driver for the UAV systems was its total weight. Figure 32 depicts this relationship, which yields a very favorable coefficient of determination (R^2) value of 0.93.

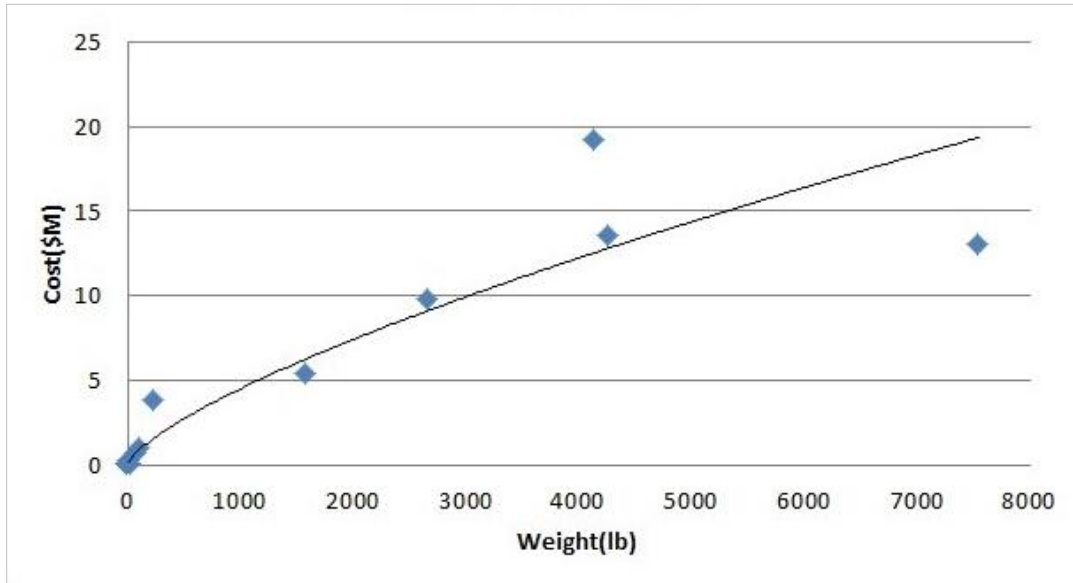

Figure 32. Cost as a Function of a UAV's Total Weight CER

The data presented in Figure 32 results in the following CER equation:

$$\text{Procurement Cost (FY15 \$M)} = 0.0304 \times \text{Total Weight}^{0.7232} \text{ (lb)}$$

Similarly, the SEA-21A project team was able to develop a relationship for the total speed of a UAV based upon its weight. This was done in order to help quantify a representative weight for a candidate UAV system based on a required speed. For example, the project team is interested in determining the expected weight of a UAV based on the speed at which it will need to transit to an AOU 300 nm away from the launch platform. This relationship is depicted in for representative UAV systems possessing transit speeds ranging from 35 to 117 knots.

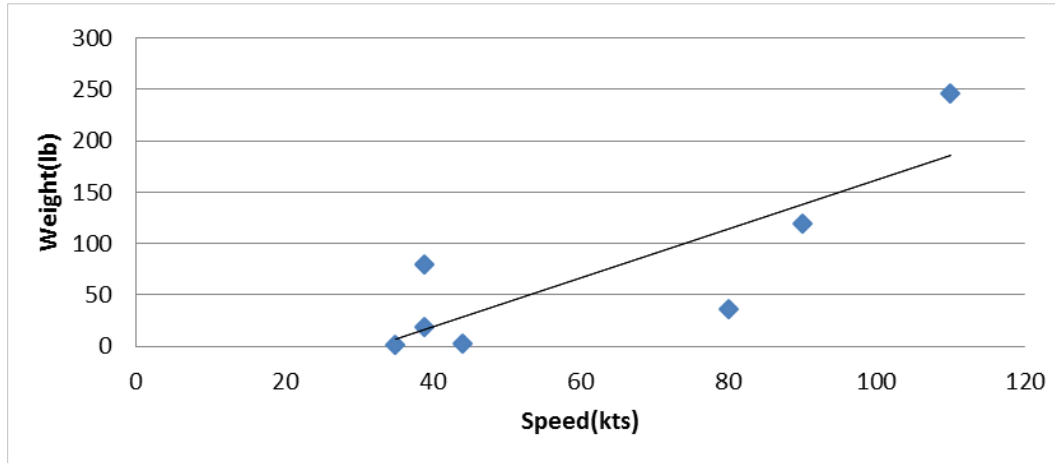

Figure 33. Speed as a Function of a UAV's Total Weight

While the R^2 isn't exceptional (0.68), the data do provide a reasonable relationship for estimating a candidate UAV's weight based on a required speed:

$$\text{Total Weight (lb)} = [4.65 \times \text{Speed (kts)}] - 76.9$$

Using both the CER and the above relationship for total weight as a function of speed developed from Figure 32 and Figure 33, respectively, Table 25 was constructed and lists the expected weights and procurement costs for potential UAVs to be included in the SEA-21A SoS design recommendation.

Table 25. UAV Procurement Cost as a Function of Speed and Weight

UAV Speed (kts)	UAV Weight (lbs)	UAV Procurement Cost (FY15 \$M)
70	90.48	0.79
90	136.98	1.07
110	188.13	1.34
130	2,727.76	9.28
150	3,579.56	11.30

From the data presented in Table 25, it is clearly evident that attempting to procure a UAV that can fly faster than 110 kts is infeasible. Simply stated, a UAV weighing more than a metric ton is likely incapable of launch and recovery operations by a typical U.S. Navy surface combatant, regardless of sea state.

2. UAV Architecture Life Cycle Cost Estimate

With a meaningful CER established for the UAV candidate architecture, the SEA-21A project team moved began formulating a LCCE. Developing a LCCE is a useful tool for decision makers to evaluate the total cost of a system “from the cradle to the grave” (i.e., from conceptual design to ultimate disposal). The five different UAV configurations being evaluated by SEA-21A and their respective estimated LCCEs are tabulated in Table 26.

Table 26. Total LCCE for Five Potential UAV Systems as a Function of Speed

UAV Speed (kts)	RDT&E Costs (FY15 \$M)	Acquisition Costs (FY15 \$M)	O&S Costs (FY15 \$M)	Disposal Costs (FY15 \$M)	Total LCCE (FY15 \$M)
70	1.491	5.070	8.201	0.149	14.912
90	2.020	6.867	11.108	0.202	20.197
110	2.529	8.600	13.911	0.253	25.293
130	17.517	59.557	96.342	1.752	175.166
150	21.330	72.520	117.312	2.133	213.295

From the data summarized in Table 26, it is clearly shown that the LCCE increases by a factor of nearly seven when attempting to fly beyond 110 kts. To further illustrate the impact of a UAV’s speed on its LCCE, a plot of the data shown in Table 26 is displayed in Figure 34.

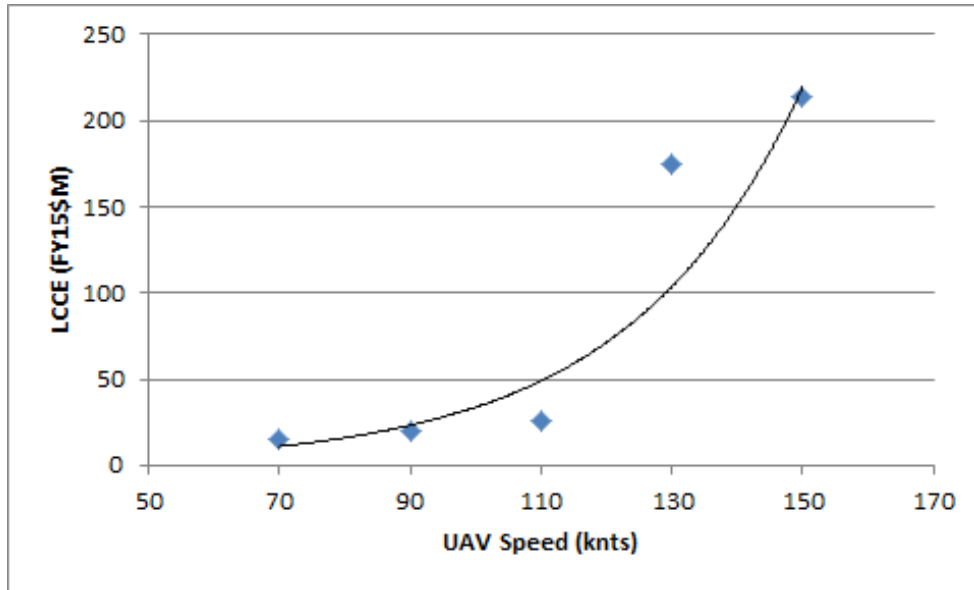

Figure 34. LCCE as a Function of UAV Speed Regression Model

From Figure 34, it is evident that the LCCE for a UAV system increases exponentially when its required speed exceeds 110 kts. This establishes an important costing consideration when evaluating potential system solutions for the UAV candidate architecture.

With a similar relationship at the 110 kts data point evident in the UAV weight/speed data presented in Table 25, it was clear to the SEA-21A project team that the UAV system solution will exist around this airspeed – both from a weight (i.e., size) and cost perspective.

D. PREPOSITIONED NETWORK ARCHITECTURE COST ESTIMATION DATA ANALYSIS

1. Procurement Costs

As previously discussed, the SEA-21A project team took a more direct approach in the cost estimation analysis of the PPN candidate architecture compared to that of the UAV, in that it relied heavily on the existing cost data for NOAA’s DART buoy system, the U.S. Navy’s Seaweb underwater sensor network, and Liquid Robotics’ Wave Glider. The procurement cost for a Seaweb acoustic modem is listed as \$10,000 and, based on

discussions with Seaweb engineers, its battery lasts approximately months (Engineer A, interview with SEA-21A Project Team Member A, May 22, 2015). When the modem's battery life is depleted, the modem will either have to be retrieved to restore functionality or a new model deployed in its place. Depending on the depth of the water in which the modem requiring battery replacement has been placed, this is likely to be cost prohibitive.

The procurement costs associated with the Seaweb gateway buoy, on the other hand, were derived from discussions with Seaweb, Wave Glider, a DART buoy engineers (Engineer B, email message to SEA-21A Project Team Member A, May 15, 2015; Engineer C, email message to SEA-21A Project Team Member A, May 4, 2015; Engineer A, interview with SEA-21A Project Team Member A, May 22, 2015). The life of the gateway buoys in the Seaweb underwater sensor network is assessed to be approximately 10 years with periodic resetting and maintenance. This maintenance is more easily conducted than modem battery placement because the gateway buoys are much more accessible in that they reside on the surface of the water as shown in Figure 35.



Figure 35. Seaweb Gateway Buoy Maintenance (Honegger 2011)

2. Research, Development, Test, and Evaluation Costs

In constructing an RDT&E cost estimate for the PPN candidate architecture, the SEA-21A project elected to use an analogous approach. NOAA's Pacific Marine Environmental Laboratory (PMEL) team stated that it took four to five years to conceive, develop, test, and field two generations of DART systems before transferring them to an operational status for industry use (Christine Meinig, email message to Paul Harris, May 4, 2015). Due to the similarities between the DART buoy system and the vision for the SEA-21A PPN candidate architecture, the project team elected to use the analogy method in estimating the PPN's RDT&E costs. According to PMEL's chief engineer, NOAA budgeted \$500,000 for the RDT&E of the DART buoy, this figure will serve an initial RDT&E cost estimate in building the overall LCCE for the project team's PPN architecture.

3. Operations and Support Costs

In estimating the O&S costs of the candidate PPN architecture, the SEA-21A project team utilized Liquid Robotics' Wave Glider total ownership cost models and the current price of fuel to develop a rough order of magnitude costing estimate (Graham Hine, email message to Paul Harris, May 15, 2015). Liquid Robotics' total ownership cost models were provided to SEA-21A through correspondence with their product management team. With supporting O&S data in-hand and using the notional scenario discussed in Chapter V, U.S. Navy assets capable of deploying PPN nodes/sensors/buoys were considered to be operating out of Singapore and would fly/sail as required to establish PPNs in the vicinity of the sea lanes and open ocean areas surrounding Natuna Besar.

Fuel consumption rates were obtained for the Allison T-56 engine found in the C-130 Hercules aircraft and the Colt-Pielstick engine found on United States Naval Ship (USNS) ships. Aircraft were assumed to be capable of carrying and deploying 20 Seaweb modems, while the ships modelled in our analysis were assumed to be capable of carrying/deploying 30 modems. Additionally, fuel costs were based on available JP-8

aircraft fuel and Bunkers Marine sea vessel fuel pricing data (Defense Logistics Agency 2015).

4. Pre-positioned Network Life Cycle Cost Estimate

Using the cost estimates developed for the procurement, RDT&E, and O&S costs, the SEA-21A project team was able to develop a representative LCCE (excluding disposal cost per the stated assumptions) for the PPN candidate architecture. The LCCE costs for the three sensor acoustic range configurations (PPN1, PPN2, PPN3) as discussed in the previous chapter are tabulated in Table 27 Total LCCE for Three Potential PPN Systems.

Table 27. Total LCCE for Three Potential PPN Systems

PPN Configuration	# of Buoys Required	RDT&E Costs (FY15 \$M)	Procurement Costs (FY15 \$M)	O&S Costs (FY15 \$M)	Total LCCE (FY15 \$M)
PPN 1	53	0.5	21.60	47.19	69.30
PPN 2	37	0.5	17.68	37.45	55.64
PPN 3	19	0.5	13.27	26.52	40.30

From the data presented in Table 27, Figure 36 was generated and depicts a linear relationship between the number of buoys required and the total LCCE for each of three PPN configurations ($R^2 = 1$).

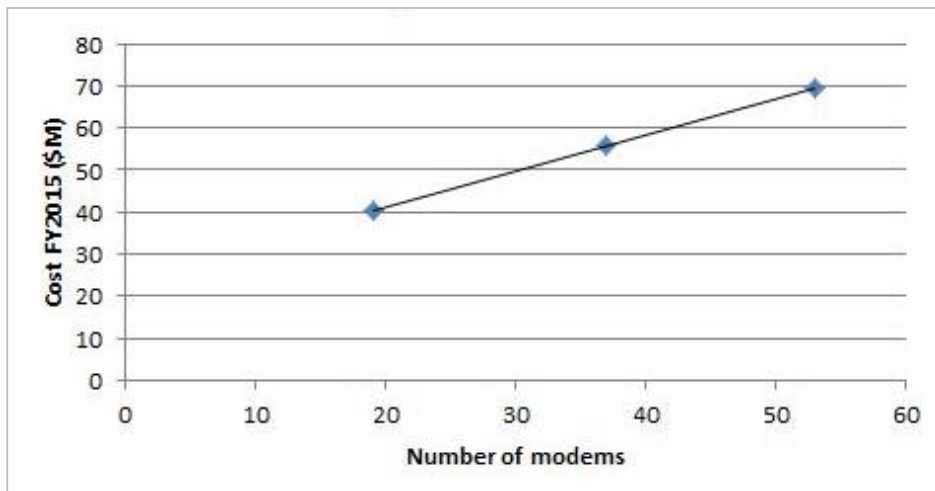

Figure 36. PPN LCCEs as a Function of Modems Required

From the resulting plot depicted in Figure 36, the following LCCE relationship was developed for the PPN candidate architecture:

$$PPN\ LCCE\ (FY15\ \$M) = 0.853 \times \# \text{ of Modems Required} + 24.09$$

From the modeling and simulation results discussed in Chapter VI, the PPN candidate architecture is nearly perfect in detecting an adversary ship once it enters the PPN's sensor field. Therefore, the size of the overall PPN sensor field and the number of fields that are ultimately deployed will yield a more accurate LCCE for the PPN candidate architecture. This was a significant factor in the overall performance vs. cost assessment and KPP trade analysis conducted by the SEA-21A project team in developing its design solution recommendation.

E. CONCLUSION

In comparing the five UAV and three PPN candidate architectures and their respective LCCEs, it was shown that UAV costs increase exponentially when its required speed exceeds 110 kts. Similarly, as the desire for increased PPN area coverage goes up, the number of required nodes and its respective LCCE increases linearly. However, the key takeaway in evaluating the cost of a PPN architecture lies not only in the number of nodes and the size of the networks, but in the costs to maintain such a system where the battery life of the submerged nodes are the limiting factor for its persistence. Using Seaweb, for example, whose modems' battery life is approximately three months, and assuming there was requirement to maintain a PPN for a period of a year, the cost of that PPN network would be quadruple the LCCE described in this chapter. While UAVs 1-3 all possess LCCEs lower than the three PPNs as shown in Figure 37, this is still an important point to consider when evaluating the relative overall cost effectiveness of candidate architectures that will be discussed in the following chapter.

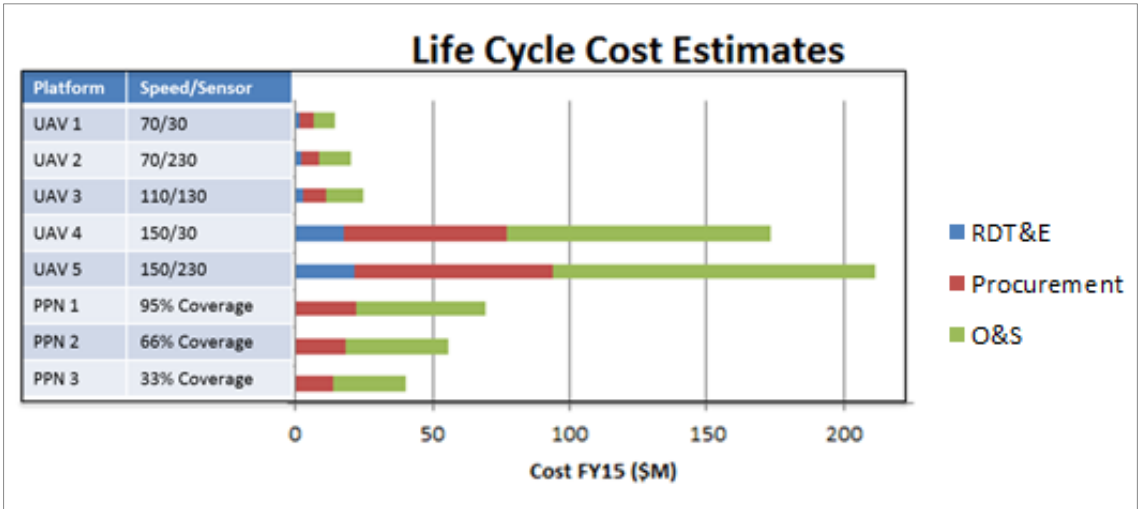

Figure 37. Comparative LCCE Breakdown for Candidate Architectures

IX. SEA-21A RECOMMENDED DESIGN SOLUTION

Throughout the SEA-21A project team's efforts to identify a coherent capability needs statement from its initial project tasking, this study experienced various changes in direction and scope. Early iterations of the initial tasking statement explored concepts involving organic ISR platforms that extended current U.S. Navy surface combatants' sensor capabilities. However, through continuous stakeholder interaction and using its tailored systems engineering process model, SEA-21A redefined the problem and shifted its focus to advancing the capability for SAG assets to organically complete an OTH kill chain. **The ultimate recommendation of this capstone project is for the U.S. Navy to develop organic long-range, persistent UAV platforms and a complementary extended-range weapon for hunter-killer SAGs to prosecute OTH surface targets in an A2/AD environment.**

A. SURFACE FORCE COMPOSITION

The composition of surface forces is key to the successful employment of SEA-21A's recommended SoS. In an A2/AD environment without the support of an aircraft carrier and its embarked air wing, the supporting surface force structure will need to include a combination of *Arleigh Burke*-class DDGs, *Zumwalt*-class DDs, and *Freedom*- or *Independence*-class LCSs/FFs. A combination of these classes of ships, referred to as a hunter-killer SAG, will facilitate the most effective employment of the combined capabilities of the associated platforms and the SEA-21A proposed SoS.

The benefits of employing such a hunter-killer SAG comprising two or more surface units can not only be seen in the group's ability to leverage the warfighting capabilities of a network-centric UAV OTH SoS across its membership, but also in the fact that a multi-ship SAG inherently alleviates a significant number of the logistical challenges associated with employing such a SoS. For example, SAG members could share sortie requirements and even spare parts using their existing SH-60 Seahawk detachment for vertical replenishment, personnel movement, and other logistical support requirements.

B. UAV SYSTEM

Interoperability between the SoS, surface combatant, and the extended-range weapon is critical for development of the OTHT capability. The physical dimensions of the UAV are also of great importance, as an optimal tradeoff between size and functionality must be achieved in order for the UAV to fulfill its intended mission without being cost-prohibitive (reference Chapter VIII). The embarked size of the UAV system may also affect the composition of the ship's crew due to its likely effect on the surface combatant's resident SH-60 detachment, and the specialized equipment and personnel that may be required for its operation and maintenance.

While SEA-21A conducted an analysis of five likely combinations of UAV speed and sensor range (as listed in Table 28 for convenience), the initial modeling data, unsurprisingly, favored the fastest UAV with the longest sensors based upon a scenario that required it to transit 300 nm and search a 676 nm² AOU.

Table 28. Summary of UAV Variants' Speed and Sensor Radius

Variant	Speed (kts)	Sensor Radius (nm)
UAV 1	70	30
UAV 2	70	230
UAV 3	110	130
UAV 4	150	30
UAV 5	150	230

When considering cost, SEA-21A's analysis concluded that a UAV system's LCCE increases exponentially as its speed increases beyond approximately 110 kts. This represents a significant cost increase between medium UAVs, such as the MQ-1 Predator, and large UAVs, such as the RQ-4 Global Hawk. This is generally the result of the increased speed required of a larger airframe that carries a robust sensor packages. Table 29 (a reiteration of the data previously presented in Table 25) restates the speed, weight, and procurement costs of the five UAV configurations considered by the SEA-21A project team.

Table 29. Summary of UAV Configurations and Procurement Costs

UAV Speed (kts)	UAV Weight (lbs)	UAV Procurement Cost (FY15 \$M)
70	90.48	0.79
90	136.98	1.07
110	188.13	1.34
130	2,727.76	9.28
150	3,579.56	11.30

Taking into account the effectiveness analysis conducted in Chapter VII with the cost estimation models generated in Chapter VIII, a cost-effectiveness plot of the UAV and PPN systems was constructed in order to qualify the SEA-21A project team’s recommended solution. These data are presented in Figure 38 and clearly indicate that the PPN candidate architectures and UAVs 4 and 5 are dominated by the UAV 1-3 alternatives. The optimal location for any candidate architecture on this plot is the upper left hand corner where effectiveness is maximized at minimal cost.

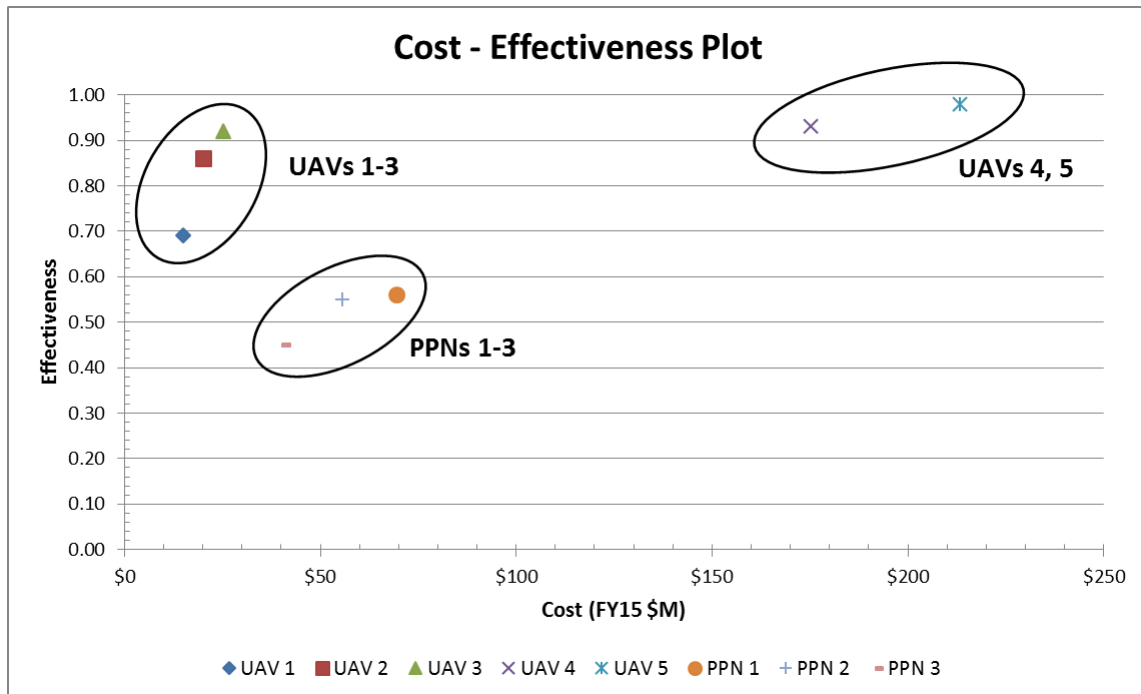

Figure 38. Candidate Architecture Cost-Effectiveness Plot

Figure 38 highlights the favorable cost effectiveness of small- to medium-weight UAVs. While the large UAVs are very effective, the same utility can be achieved for much less cost using a middle-weight UAV platform. Furthermore, the aforementioned logistical challenges associated with shipboard employment of large UAVs are simply much too difficult to overcome than those presented by smaller systems. Of note, it can be seen in Figure 38 that it is possible to purchase multiple UAV 3 platforms (each of which possess nearly the same effectiveness as a UAV 4) for the same cost as one UAV 4.

A closer look at the small- and medium-weight UAVs also suggests that for a slight cost increase, a relatively large increase in effectiveness is seen in moving from UAV 1 to UAV 2. To a lesser extent, this is also true in moving from UAV 2 to UAV 3. Additionally, the medium-weight UAV 3 achieves about the same overall effectiveness as the much more expensive (and larger) UAV 4. **Therefore, the overall cost effectiveness analysis by SEA-21A in the study of organic OTHT for the 2025 surface fleet indicates that the U.S Navy should develop an integrated network-centric surface-based UAV system capable of airspeed in excess of 110 kts and sensor ranges of greater than 130 nm.**

C. FINAL FORCE STRUCTURE RECOMMENDATION

As a result of this comprehensive study's analysis and adherence to the project team's tailored systems engineering process model, SEA-21A offers the following recommendation to the U.S. Navy for shaping its future hunter-killer SAGs in order to further advance the surface fleet's ability to organically complete the OTH kill chain through the use of an integrated UAV platform to search, target, and provide inflight updates for the employment of an extended-range weapon in an A2/AD environment against an adversary surface ship. **The future "distributed lethality" hunter-killer SAG force structure is likely to resemble the following composition:**

- **2 *Arleigh Burke*-class Flight III DDGs with an organic SH-60 helicopter detachment, integrated UAV system, and extended-range OTHT weapons; and**
- **2 *Freedom*- or *Independence*-class LCSs/FFs with an UAV-tailored OTHT mission module.**

While the aforementioned force structure represents only one potential hunter-killer SAG composition, there will likely be a number of different configurations that the U.S. Navy surface fleet will tailor and ultimately deploy in order to establish and maintain control of the seas. Regardless of its composition, however, the hunter-killer SAGs of 2025 will target threats at unprecedented ranges through the integration of an organic UAV system paired with an extended-range weapon into its existing and future surface combatants as part of the distributed lethality concept.

THIS PAGE INTENTIONALLY LEFT BLANK

X. RECOMMENDED FUTURE ANALYSIS

While the SEA-21A initial tasking statement led the project team to investigate potential maritime ISR solutions for the U.S. Navy in the 2025-2030 timeframe, continued interaction with stakeholders and adherence to the team's systems engineering process model resulted in refining the stakeholders' effective needs while also completely redefining the assigned tasking statement at the halfway point of their nine-month capstone project to recommend means of advancing the U.S. Navy's OTHT capabilities in an A2/AD environment for the 2025 surface fleet.

Though the team primarily focused on properly defining and quantifying its recommended design solution, the following concepts are proposed by SEA-21A for additional analysis. It is important to note that these areas for future study are not exhaustive, and that continued stakeholder engagement as a result of the project team's analysis will likely lead to the identification of avenues of relevant further investigation.

A. SHIP-LAUNCHED UAV INTEGRATION CHALLENGES

While the U.S. Navy has demonstrated a proof-of-concept at sea with UAVs, such as ScanEagle and the MQ-8 Fire Scout, large-scale integration of UAV platforms with existing DDGs/CGs/LCSs/FFs will require additional development. The SEA-21A SoS design recommendation involves the use of a persistent UAV that can be launched, operated, and recovered from current and future U.S. Navy surface combatants. While the use of a rotary wing platform, such as Fire Scout, alleviates most of the innovation and integration challenges required to launch and recover a fixed wing UAV aboard a ship, the lower relative persistence, reduced cruising altitude, and increased detectability of rotary wing UAVs require that additional research should be conducted involving the use of fixed wing UAVs at sea.

Aside from the obvious differences in UAV platform architectures (i.e., rotary wing vs. fixed wing), the U.S. Navy should also quantify the extent to which its OTHT UAV platform(s) will utilize autonomy. While certain flight regimes, such as takeoff, transit, loiter, and landing, are often automated UAV functions much like those of modern-day

commercial aircraft, the U.S. Navy (and DoD, for that matter) needs to identify the extent to which its UAV will operate in this regime. The degree to which these UAV systems utilize autonomy will have second- and third-order effects on hardware and software integration, manpower and training, as well as logistical support for SEA-21A's proposed OTHT SoS.

B. IMPROVING THE SPEED, RANGE, AND LOGISTICS OF SHIP-LAUNCHED UAVS

As evidenced in Chapter VIII of this project report, the direct correlation between a UAV's LCCE and its size and speed warrant continued dedication by the DoD and industry in the development of platforms and technologies that utilize advanced materials, miniaturize components, and enhance energy storage, replenishment, and efficiency. All of these identified areas are critical in the development and evolution of ship-based UAVs. The harsh saltwater environment, uniquely characteristic of underway operations at sea, presents a great challenge in the development of materials, components, and subsystems that can operate for extended periods of time while subjected to such things as water intrusion and accelerated corrosion. With improvements in materials and energy management, ship-based UAVs will be able to provide additional persistence and range in facilitating the OTHT mission.

Additionally, the logistical challenges inherent in operations from the sea will need to be tailored in order to ensure that maintenance materials, replacement parts, and personnel training programs (both specialized and on-the-job) are properly defined and established for fleet-wide use. This not only facilitates an optimal level of readiness for the machines, but also for the sailors responsible for their operation and maintenance. It is also likely that with additional development and technological maturity in autonomy that the need for an individual to have attended flight training or possess advanced flying skills will no longer be necessary to operate these UAV systems.

C. ENGAGE WITH WARFARE DEVELOPMENT COMMANDS TO DEVELOP SURFACE-BASED OTH CONOPS

While not specifically addressed in the SEA-21A capstone project, CONOPS developed in conjunction with NWDC and NSMWDC for the use and employment of UAVs to project U.S. Navy maritime power OTH is of significant interest. This will help determine the best methods of UAV employment and tactical integration while enabling the development of surface-based UAV doctrine that is properly aligned with future U.S. Navy SAG compositions and the surface fleet's concept of distributed lethality.

Additionally, while the OTH weapon to be paired with the UAV system in completing the kill chain was not specifically addressed by the SEA-21A project team in this analysis, engaging NWDC in the development of the OTH CONOPS for the team's recommended SoS will also ensure that the best long-range weapon is selected for use. The DoD and U.S. Navy have made significant strides in the development of the Long-Range Anti-Ship Missile (LRASM) and conducted a successful test involving the use of a ship-launched modified Tomahawk cruise missile to strike a moving maritime surface-target with terminal guidance/direction provided by an airborne FA-18 Super Hornet. It is recommended that the U.S. Navy conduct additional analyses to determine whether it is more cost effective to modify an existing missile system, such as Tomahawk, or to procure a completely new system, such as LRASM. While modifying an existing (and likely aging) system alleviates many developmental and integration challenges characteristic of new systems, investing in a completely new system may be more cost effective in the long run simply by virtue of its additional capabilities and future growth potential when compared to that of the existing system.

D. ASSESS THE IMPACT OF RECOMMENDED SOLUTIONS ON PHASE 0 OPERATIONS

Though the SEA-21A capstone project sought to develop a recommended design solution for the U.S. Navy in conducting surface-based OTH in the 2025-2030 timeframe, the use of such a SoS should not be limited to actual targeting operations that result in the kinetic engagement of an OTH surface vessel. The surface-based UAV OTH SoS would undoubtedly be utilized by SAG assets in enhancing their overall battlespace situational

awareness during routine, day-to-day operations. Such a CONOPS for use in Phase 0 (shaping the environment) would best be developed in conjunction with NWDC and would provide U.S. Navy surface combatants with not only a surface picture that reaches beyond the range of their current sensors, but also additional fidelity and targeting data (i.e., persistent organic ISR) for contacts approaching that pose a threat to their vital areas.

E. HYBRID UAV-PPN SYSTEM OF SYSTEMS ARCHITECTURE

While the results of this study indicate the UAV candidate architecture is the optimal solution of those considered by the SEA-21A project team, the various UAV and PPN configurations offer their own respective strengths that could be leveraged by a hybrid architecture that incorporates elements of both. If the detection speed and accuracy of the PPN architecture could be coupled with the adaptability and IMINT sensor capabilities of the UAV architecture, the potential for a superior hybrid architecture could be achieved. A suggested tradeoff in this area for future study may include a PPN that is spread out over a larger area using a minimal number of sensor nodes and surface gateways. While this would affect the PPN's probability of detection at the behest of greatly extending its area of coverage, a persistent UAV could possibly be used to mitigate this effect.

F. ANTICIPATE ADVERSARIAL TECHNOLOGY ADVANCEMENT

Our adversaries have proven themselves capable of significant advancements in weapons technologies in order to meet or exceed our current military capabilities. With that said, this capstone project specifically highlighted the need for significant improvement in the prosecution of OTH targets by the U.S. Navy surface fleet. In order to both enhance our own capabilities while staying ahead of the threat, accurate assessments of current and future adversarial military systems must remain a central focus for the DoD and the U.S. Navy. If the U.S. is to maintain the offensive edge across every domain, staying ahead of our adversaries in the advancement of military technology will be essential.

APPENDIX A. SEA-21A TASKING LETTER



7 August 2014

Memorandum for Systems Engineering Analysis Cohort 21 (SEA21)

Subj: FY2015 SEA21 Capstone Projects: Tasking and Timelines

Enclosures:

Tab A: Maritime ISR in the Contested Littorals

Tab B: Conducting Expeditionary Operations in the Contested Littorals

Tab C: Proposal for Coordinated Naval Postgraduate School Cross-Campus Project
Warfighting in the Contested Littorals

1. This memorandum provides the FY2015 guidance for the conduct of the Systems Engineering Analysis (SEA) integrated projects, which are required as partial fulfillment for the SEA degree. SEA students will deliver completed project reports and final briefing materials to faculty advisors in accordance with the following plan and milestones. Each group will:
 - a. SEA21 A and B will develop project proposals and management plans during the Fall Quarter AY2015. SEA21C will develop a project proposal during the Winter Quarter AY2015. These proposals and plans will serve to focus initial research and analysis. These plans will be reviewed and updated frequently as research progresses.
 - b. Conduct project reviews approximately every six weeks, finishing with a final brief to interested stakeholders on and off campus.
 - c. Assign a report lead from your team. Work closely with faculty advisors to prepare the final reports for faculty advisor signature by 4 work-weeks before graduation. The final reports are then due to the SEA chairman one week later; and to the Operations Research and Systems Engineering department chairmen one week before graduation.
2. SEA students are expected to identify and integrate students and faculty from across the campus – and also from outside NPS – to participate directly in the project or to provide source documents, technical knowledge and insights, and knowledge of evolving requirements, capabilities, and systems. This participation could include students who would join project groups; students doing related individual thesis topics from TSSE, TDSI, OR, IS or SE; faculty inside or outside NPS who have expertise related to the project; and appropriately engaged government agencies and industry developers. It is the students' responsibility to integrate the efforts of outside participants in the projects. Faculty advisors and the SEA Chair will, of course, significantly assist in these efforts.
3. The analysis will employ the systems engineering and operations research methodologies presented in class work and from the project advisors. The role of the

SEA students is that of the lead project systems engineering team, working closely with other members of the project engineering teams from TDSI and other campus curricula. SEA students will be expected to define the functions and performance of systems, develop alternative architectures to meet those functions, and evaluate the alternative architectures for performance and cost. In executing these tasks, students will be defining and understanding the overall project requirements, recognizing that the definition process is iterative and will evolve as the project progresses.

4. Grades are assigned to the participants in these projects. Although work is performed as part of a team, individual performance will be the basis for this evaluation. Successful completion and documentation of the project is a degree requirement.
5. The SEA21A and B projects will build on, possibly challenge, but not replicate, other DOD and SEA projects. SEA21A will primarily examine maritime systems (unmanned and manned) to establish ISR in a contested littoral. SEA21B will concentrate on conducting expeditionary operations with emphasis on mine warfare in the contested littorals. The groups will coordinate their study efforts, since the systems developed must integrate in the challenging littoral environment. Each group will also participate and occupy leadership roles in other FY14/15 efforts at NPS aimed at exploring warfighting in contested littorals. These activities, coordinated by the Chair of Systems Engineering Analysis and Chair Warfare innovation, are described in Tab C.

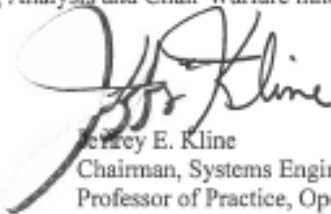

Jeffrey E. Kline
Chairman, Systems Engineering Analysis Curriculum
Professor of Practice, Operations Research
Naval Postgraduate School
Monterey, CA 93908

Distribution: SEA21 students; Profs. Hughes, Dell, Whitcomb, Langford, Chung, Stevens, Solitario, Kline, Harney, Papoulias, Sepp, Boger, Brutzman, Buettner, President Route; Provost Hensler; Deans Durkee, McCormick, Paduan, and Moses, CAPT Daniel Verheul, CAPT Jeff Hyink; CDR Aparicio, LCDR Littrell, Dr. Anthony Pollman, RADM Williams, RADM Ellis, RADM Breckenridge (OPNAV N9I), Mr. Mike Novak (OPNAV N9IB), Mr. Chuck Worchado (N81B), Mr. Bill Glenney (SSG), Ms. Tanya Horsey, and Ms. Kathie Cain

TAB A

SEA 21A Tasking Maritime ISR in the contested littorals

"Design a fleet system of systems and concept of operations for employment of a cost effective and resilient maritime ISR system capable of collecting, fusing, and disseminating critical environmental and threat information in a contested littoral area in the 2025-2030 timeframe. Consider manned and unmanned systems in all domains to provide sufficient information to support effective tactical offensive operations. Consider employment requirements, operating areas, bandwidth and connectivity, interoperability, sensor data processing, transfer and accessibility, logistics, and basing support in forward areas or from CONUS bases. Generate system requirements for platforms, sensors, and communications in a challenging EM environment. Evaluate swarm concepts for inclusion in your solution. Then develop alternative architectures for platforms, sensors, manning, command and control, intelligence collection/dissemination and consumption, communication and network connectivity, and operational procedures. Address the costs and effectiveness of your alternatives."

Advisor:

Dr. Timothy Chung, Systems Engineering Department

Subject Matter Experts:

RADM Rick Williams, USN (Ret), Mine and Expeditionary Warfare Chair

RADM Jerry Ellis, USN (Ret), Undersea Warfare Chair

CAPT Daniel Verheul, USN, Senior NPS Intelligence Officer

Professor Wayne Hughes, CAPT, USN (Ret), Operations Research Department

Professor Jeff Kline, CAPT, USN (Ret), Operations Research Department

THIS PAGE INTENTIONALLY LEFT BLANK

APPENDIX B. EADSIM MODELING SPECIFICS

A. MODELING IN EADSIM

This appendix provides additional detail concerning the initial EADSIM modelling efforts for the SEA-21A project team.

1. Entities within EADSIM

Table B.1 summarizes the entities created in EADSIM and the models used for its respective elements.

Table B.1. Entities created in EADSIM

Entity (System)	Elements			
	Platform (Airframe)	Weapon	Sensor	Comms
2015_Luyang-II	RedShipDestroyer	64 x YJ-12	GenericESM80	RedRadio
2025_Luyang-II	RedShipDestroyer	64 x YJ-12 64 x RedShipSAM	GenericESM80	RedRadio
2015_Aircraft_Carrier	BlueShipCarrier	NA	NA	BlueRadio
2015_Ticonderoga	BlueShipCruiser	8 x Harpoon	GenericESM80	BlueRadio
2015_Arleigh_Burke	BlueShipABDestroyer	8 x Harpoon	GenericESM80	BlueRadio
2025_Zumwalt	BlueShipZWDestroyer	64 x LRASM	GenericESM80	BlueRadio
2025_Littoral Combat_Ship	BlueShipFrigate	64 x LRASM	GenericESM80	BlueRadio
2015_E2_Hawkeye	BlueAirTransport	NA	GenericRDR400	BlueRadio
2025_E2_Hawkeye	BlueAirTransport	NA	GenericRDR400	BlueRadio
2015_F-18	BlueAirFighter	4 x AGM-154	AB_Radar(ACF T)	BlueRadio
2025_UAV	BlueAirUAV	NA	GenericRDR250	BlueRadio

Entity (System)	Elements			
	Platform (Airframe)	Weapon	Sensor	Comms
2025_UUV	BlueShipUUV	NA	GenericSonar15	BlueUnderwaterRadio
2015_LRSR	RedSensorNode	NA	GenericRDR500	RedRadio
2025_PLUS	BlueUnderwaterNode	NA	GenericSonar40	BlueUnderwaterRadio

2. Model Attributes

Tables B.2 through B.6 list the attributes used by each model for the respective elements.

Table B.2. Platform Element Attributes

Platform	RCS (m ²)	Max Speed (kts)
RedShipDestroyer	8000	30
BlueShipABDestroyer	10000	30
BlueShipZWDestroyer	8000	30
BlueShipCarrier	100000	30
BlueShipCruiser	10000	30
BlueShipFrigate	8000	30
BlueAirTransport	10	350
BlueAirFighter	3.5	800
BlueAirUAV	1	80
BlueShipUUV	1	4
BlueUnderwaterNode	NA	NA
RedSensorNode	NA	NA

Table B.3. Weapon Element Attributes

Weapon	Max Range (nm)	Velocity (m/s)	P _k
YJ-12	200	1400	30%
RedShipSAM	50	1400	65%
Harpoon	60	270	30%
LRASM	500	310	30%
AGM-154	70	310	30%

Table B.4. Sensor Element Attributes

Sensor	Max Range (nm)	Field of View (° in Az, El)	Sweep Time for 360° (s)
AB_Radar(ACFT)	30nm	120,175	3
GenericESM80	80nm	360, 180	3
GenericRDR500	500nm	360, 180	6
GenericRDR400	400nm	360, 180	6
GenericRDR250	250nm	360, 180	6
GenericRDR250_NoRemoteTracking	250nm	360, 180	6
GenericSonar15	15nm	360, 180	3
GenericSonar40	40nm	360, 180	3

Table B.5. Communications Equipment Element Attributes

Comms	Power (dB)	Az, El (°)
RedRadio	45	360,90
BlueRadio	55	360,90
BlueUnderwaterRadio	5	360,90

Table B.6 lists the various PRC military facility locations modelled in the South China Sea region.

Table B.6. Regional Base Locations

Military Facility	Latitude (Decimal ° N)	Longitude (Decimal °E)
Changi Airbase	1.37	103.98
Clark Freeport Airbase	15.18	120.57
Kadena Airbase	26.35	127.76
Yuling Naval Base	18.22	109.64

B. BEHAVIORS

The behaviors of the U.S. and adversary ships are the same in all scenarios. Both of them will travel along their scripted waypoints and engage any ships of the opposing force. The ships detect opposing forces via one of the following ways:

- On-board radar (55 nm); and
- Remote tracks provided by supporting assets, such as an E-2D Hawkeye or PLUS.

The ships are able to engage one another using their on-board radar or off-board remote tracks. If an opposing ship is beyond the maximum range of the employing ship's surface-to-surface weapon system, the employing ship will depart from its scripted waypoint sequence and sail towards the opposing ship in order to bring it to within the maximum employment range of its weapon system.

C. EADSIM PROOF OF CONCEPT SCENARIOS

Scenarios were created in EADSIM to assess its viability as a modelling tool for the analysis required of the SEA-21A capstone project. Remote track firing, as utilized in the EADSIM, was deemed to be essential to simulating the OTHT capability and is presented in the following scenarios.

1. 2015 Proof of Concept Scenario

In this scenario, a *Luyang* cruiser sails out of Yuling naval base on a patrol. The U.S. SAG is standing by in the South China Sea and receives the *Luyang*'s link track from an airborne E-2D Hawkeye. With actionable targeting information in-hand, the U.S. SAG maneuvers to close within surface-to-surface weapons engagement range to the *Luyang*. This proof of concept scenario is depicted in Figure B.1.

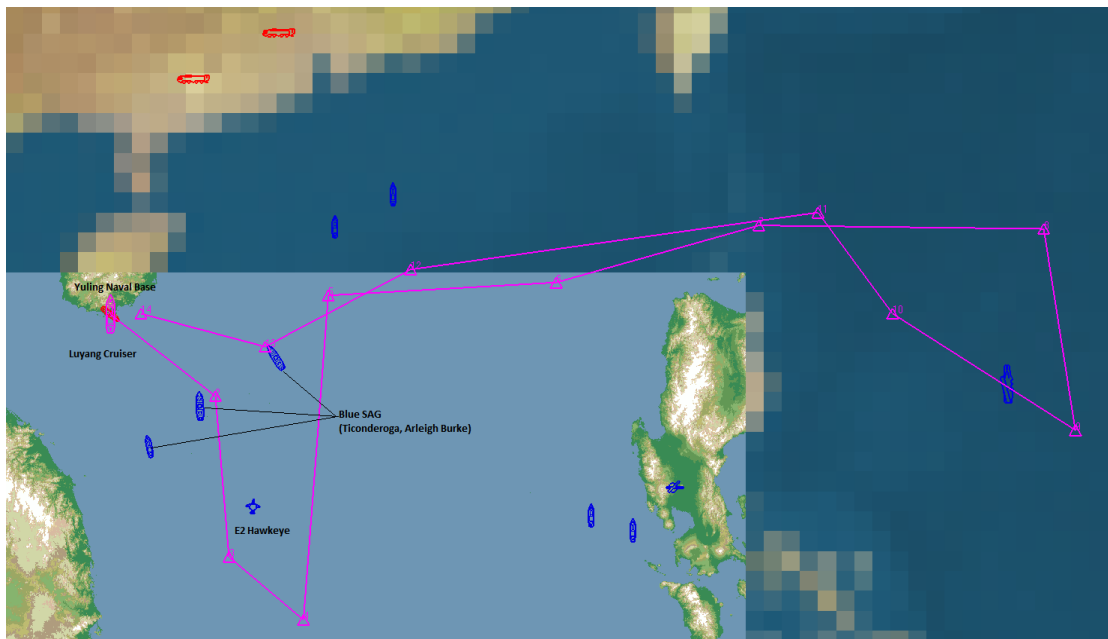

Figure B.1. 2015 Proof of Concept Scenario Depiction

2. 2025 Proof of Concept Scenario

In this scenario, the PLAN forces have established a blockade of Natuna Besar. Undersea sensor networks were deployed by the PLAN in an effort to provide tracks on U.S. surface combatants to be engaged using YJ anti-ship missiles from the *Luyang* cruiser. A general depiction of this scenario is shown in Figure B.2.

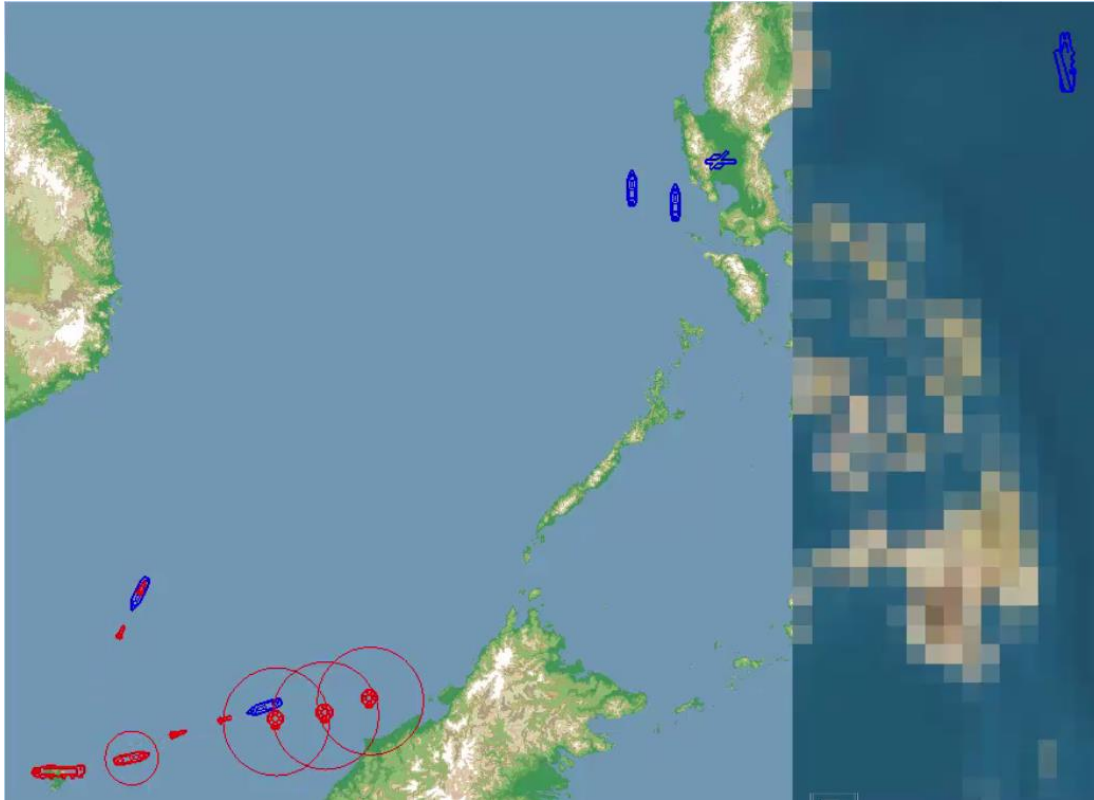

Figure B.2. 2025 Proof of Concept Scenario Depiction

D. EADSIM STUDY SCENARIOS

In the 2015 baseline scenario, hostilities are assumed to have been declared as the PLAN deploys a *Luyang* cruiser from the Yuling naval base on a patrol in the nearby regions of the South China Sea. Its aim is to assert its naval power in the region and to confront the U.S. surface fleet already in the region. For the purposes of brevity and correlation with applicable figures, the U.S. forces with heretofore be referred to as “Blue” or “Blue Forces,” and the PLAN/PRC assets referred to as “Red” or “Red Forces.”

1. 2015 Baseline Scenarios

a. Scenario A1: 2015 Red vs. Blue with Air Support

A Blue carrier with a Blue SAG of six ships is moving towards Red SAG of six ships in the open water of the South China Sea.

1. Environment

A Red SAG is defending the area around Natuna Besar and engaging any Blue Forces that become a factor. Red forces are greatly displaced from supporting Red airbases and, therefore, are not able to leverage any air support. Blue Forces aim to dislodge the Red SAG from the area using the CSG's embarked air wing.

2. Red Force Composition and Capabilities:

- Six *Luyang-II*s in a line abreast formation steaming at 20 kts;
- 80 nm fully networked electronic support measures (ESM) sensor range;
- 64 VLS cells on each ship possessing YJ-12 surface-to-surface missiles;
- YJ-12 missiles possess a nominal range of 200nm and fly at Mach 4 with a notional 0.3 P_k against Blue surface combatants;
- Red Force doctrine consists of firing a salvo of two YJ-12 missiles at with a 3-4 s interval between missiles;
- *Luyang-II*s possess air defense systems of up to 64 missiles with a 50 nm engagement range and a 0.65 P_k against Blue Force F-18s; and
- *Luyang-II*s fire a salvo of two missiles in single volley, resulting in single-shot P_k of 0.8775 against Blue Force F-18s.

3. Blue Force Composition and Capabilities:

- Two *Ticonderoga*-class CGs and 4 *Arleigh Burke*-class DDGs surrounding the aircraft carrier, all ships traveling at 20 kts;
- E-2s are established overhead the Blue SAG with F-18s flying combat air patrol (CAP);
- E-2s have a nominal 400 nm communication range and fully networked with all Blue SAG assets;
- Eight F-18s can see the Red SAG via off-board link tracks;
- F-18 organic sensors have a nominal maximum range of 30 nm;
- Blue Force doctrine dictates that F-18s will be used to engage the Red SAG using AGM-84 Harpoon missiles;

- AGM-84 Harpoon missiles are assessed to have a nominal range of 60 nm and fly at Mach 0.8 with a 0.3 P_k against Red Force ships; and
- F-18s fires salvos of four Harpoons, with a notional single-shot P_k of 0.759 against Red Force ships.

4. Measurements

Measurements of interest from the EADSIM scenarios include loss ratios and the distances travelled by Blue Force surface assets. This distance data can be used to generate rough estimates of fuel consumption that may be beneficial to the surface warfare community in its efforts to streamline fuel costs. A depiction of the six vs. six 2015 baseline scenario is shown in Figure B.3.

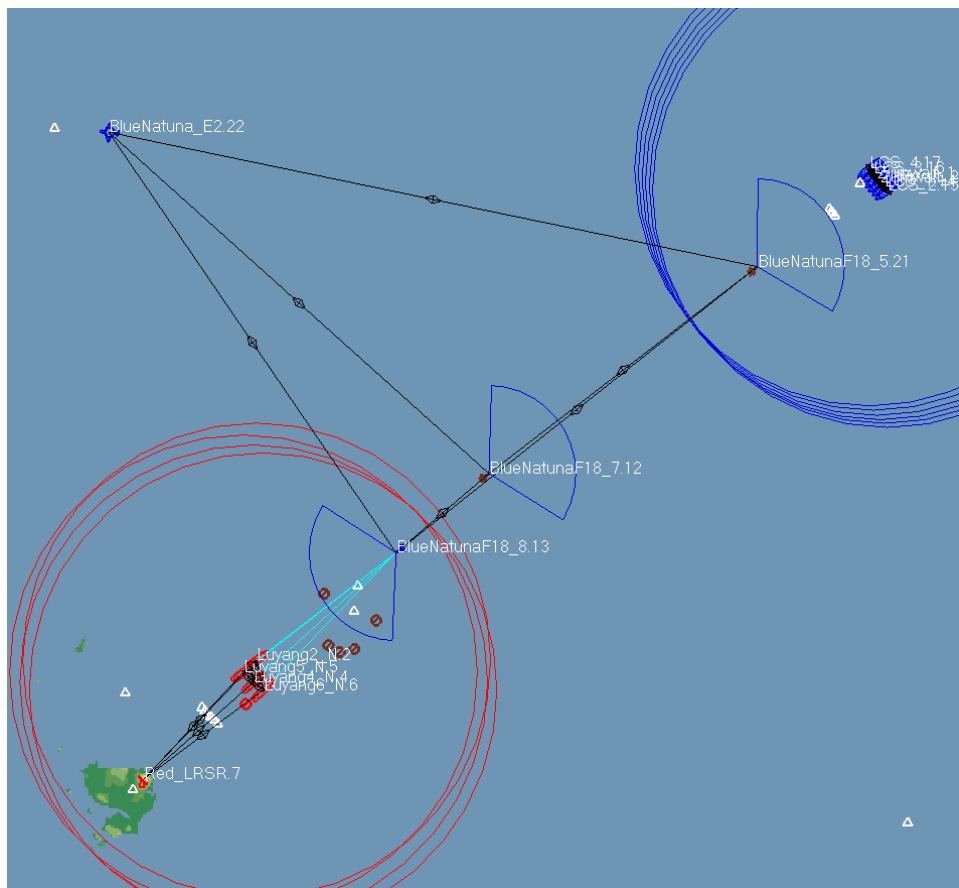

Figure B.3. 2015 Baseline Scenario with Blue Force Air Support Depiction

b. Scenario A2: 2015 Red vs. Blue without Air Support

A Blue SAG of six is moving towards a Red SAG of six in the open water of the South China Sea.

1. Environment

A Red SAG is defending the area around Natuna Besar and engaging any Blue Forces that become a factor. Red forces are greatly displaced from supporting Red airbases and, therefore, are not able to leverage any air support. However, Red Forces have deployed a DF-21 battery to Natuna Besar, thus forcing the Blue aircraft carrier to remain well outside of the area. A Red SAG is defending the area around Natuna Besar and engaging any Blue Forces that become a factor. Red forces are greatly displaced from supporting Red airbases and, therefore, are not able to leverage any air support. Blue Forces aim to dislodge the Red SAG from the area using only the surface combatants of its SAG.

2. Red Force Composition and Capabilities:

- Six *Luyang*-IIs in a picket formation northeast of Natuna Besar;
- Picket's inner and outer line formations are 15,000 yds from the island;
- *Luyang*-IIs keeps a minimum distance of 500 yds from each other;
- *Luyang*-IIs navigate in a racetrack pattern between two points;
- *Luyang*-IIs have a maximum speed of 30 kts;
- Red SAG has a fully-networked 80 nm ESM sensor range;
- Each *Luyang*-II possesses 64 VLS cells containing YJ-12 surface-to-surface missiles;
- YJ-12 missiles possess a nominal range of 200nm and fly at Mach 4 with a notional 0.3 P_k against Blue surface combatants;
- Red Force doctrine consists of firing a salvo of two YJ-12 missiles at with a 3-4 s interval between missiles; and
- Red Force has positioned one land-based long-range surveillance radar at an elevated location on Natuna Besar, resulting in a notional 500 nm detection range with 360 degrees of coverage.

3. Blue Force Composition and Capabilities:
 - Two *Ticonderoga*-class CGs and four *Arleigh Burke*-class DDGs in a line abreast formation, steaming at 25 kts;
 - Blue Force ships have a maximum speed of 30 kts;
 - Like the Red SAG, the Blue SAG possesses a fully-networked 80 nm ESM sensor range;
 - Each Blue Force SAG asset possesses eight RGM-84 Harpoon missiles each (no aspect constraints for employment);
 - RGM-84 Harpoon missiles are assessed to have a nominal range of 60 nm and fly at Mach 0.8 with a 0.3 P_k against Red Force ships; and
 - Blue Force RGM-84 firing doctrine involves firing a salvo of two missiles with four seconds between missiles.
4. Measurements

Just as in the previous scenario (A1), measurements of interest from the EADSIM scenarios include loss ratios and the distances travelled by Blue Force surface assets. This distance data can be used to generate rough estimates of fuel consumption that may be beneficial to the surface warfare community in its efforts to streamline fuel costs.

2. 2025 Future Scenarios

a. *Scenario B1: 2025 Red vs. Blue with Organic OTHH Air Platform*

A Blue Force SAG of six possessing an organic OTHH air platform is moving towards a Red SAG of six in the open water of the South China Sea

1. Environment

Red SAG is defending the area around Natuna Besar and engaging any Blue Forces that become a factor. Red forces are greatly displaced from supporting Red airbases and, therefore, are not able to leverage any air support. However, Red Forces have deployed a DF-21 battery to Natuna Besar, thus forcing the Blue aircraft carrier to remain well outside of the area. Red SAG is defending the area around Natuna Besar and engaging any Blue

Forces that become a factor. Red forces are greatly displaced from supporting Red airbases and, therefore, are not able to leverage any air support. Blue Forces aim to dislodge the Red SAG from the area using only the surface combatants of its SAG coupled with a new organic OTHT air platform.

2. Red Force Composition and Capabilities:

- Six *Luyang-II* cruisers in a line abreast formation steaming at 25 kts;
- Each *Luyang-II* possesses a maximum speed of 30 kts;
- Red SAG possesses a fully-networked 80 nm ESM sensor range;
- Each *Luyang-II* possesses 64 VLS cells containing YJ-12 surface-to-surface missiles;
- YJ-12 missiles possess a nominal range of 200nm and fly at Mach 4 with a notional 0.3 P_k against Blue surface combatants; and
- Red Force doctrine consists of firing a salvo of two YJ-12 missiles at with a 3-4 s interval between missiles.

3. Blue Force Composition and Capabilities:

- Two *Zumwalt*-class DDs and four LCSs/FFs in a line abreast formation steaming at 25 kts;
- Blue Force ships have a maximum speed of 30 kts;
- Like the Red SAG, the Blue SAG possesses a fully-networked 80 nm ESM sensor range;
- Each DDG possesses 64 VLS cells containing extended-range surface-to-surface missiles (no aspect firing constraints);
- Extended-range surface-to-surface missiles possess a nominal range of 500 nm and flies at Mach 0.9 with 0.3 P_k against Red Force ships; and
- Blue Force firing doctrine dictates the firing of a salvo of two missiles with a 3-4 s interval between missiles.

2025 B1-1:

This scenario variation includes one organic, fully-networked UAV with a 250 nm sensor range flying 90 nm in front of the Blue SAG. Blue SAG assets, however, are unable to employ on remote tracks provided by its UAV.

2025 B1-2:

This scenario variation is the same as the B1-1 scenario described above with the exception that Blue SAG assets are now able to employ on remote network tracks provided by its UAV.

2025 B1-3:

This scenario variation is the same as the B1-2 scenario described above; however the *Luyang-II* can employ its surface-to-air defense system against the Blue SAG UAV at a nominal range of 50 nm with a notional 0.65 P_k . A depiction of the 2025 EADSIM scenarios is shown in Figure B.4.

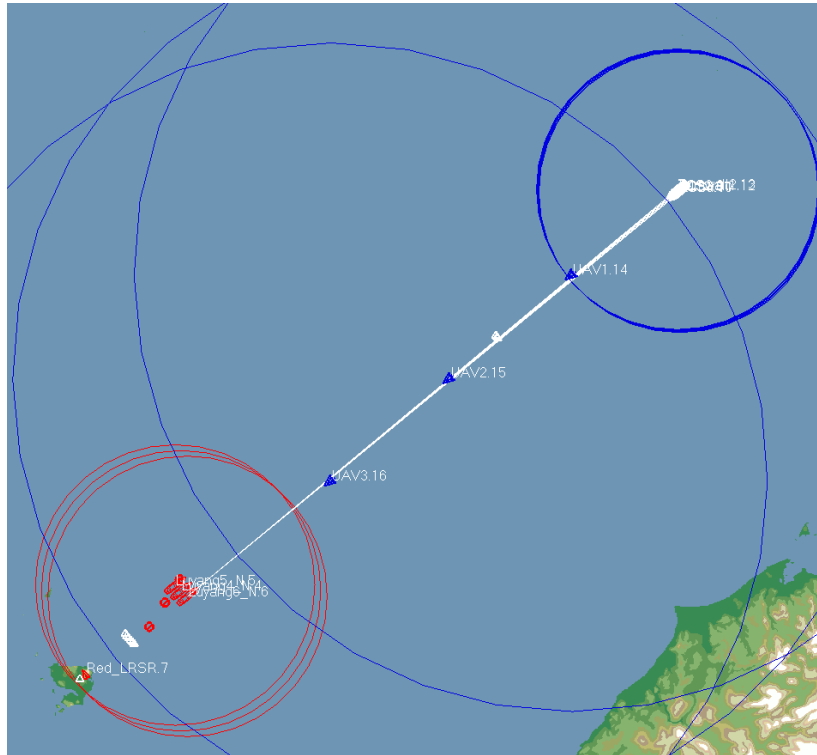

Figure B.4. 2025 EADSIM Scenarios with Blue Force OTHT Air Platform

b. Scenario B2: 2025 Red vs. Blue with Underwater Sensor Network

A Blue Force SAG of six possessing an underwater sensor network capability moving towards a Red SAG of six in the open water of the South China Sea

1. Environment

A Red SAG is defending the area around Natuna Besar and engaging any Blue Forces that become a factor. Red forces are greatly displaced from supporting Red airbases and, therefore, are not able to leverage any air support. However, Red Forces have deployed a DF-21 battery to Natuna Besar, thus forcing the Blue aircraft carrier to remain well outside of the area. A Red SAG is defending the area around Natuna Besar and engaging any Blue Forces that become a factor. Red forces are greatly displaced from supporting Red airbases and, therefore, are not able to leverage any air support. Blue Forces aim to dislodge the Red SAG from the area using only the surface combatants of its SAG and an underwater sensor network.

2. Red Forces:

- Six *Luyang-II* cruisers in a line abreast formation steaming at 25 kts;
- Each *Luyang-II* possesses a maximum speed of 30 kts;
- Red SAG possesses a fully-networked 80 nm ESM sensor range;
- Each *Luyang-II* possesses 64 VLS cells containing YJ-12 surface-to-surface missiles;
- YJ-12 missiles possess a nominal range of 200nm and fly at Mach 4 with a notional 0.3 P_k against Blue surface combatants; and
- Red Force doctrine consists of firing a salvo of two YJ-12 missiles at with a 3-4 s interval between missiles.

3. Blue Forces:

- Two *Zumwalt*-class DDGs and four LCSs/FFs in a line abreast formation steaming at 25 kts;
- Blue Force ships have a maximum speed of 30 kts;
- Like the Red SAG, the Blue SAG possesses a fully-networked 80 nm ESM sensor range;

- Each DDG possesses 64 VLS cells containing extended-range surface-to-surface missiles (no aspect firing constraints);
- These extended-range surface-to-surface missiles possess a nominal range of 500 nm and flies at Mach 0.9 with 0.3 P_k against Red Force ships; and
- Blue Force firing doctrine dictates the firing of a salvo of two missiles with a 3-4 s interval between missiles.

2025 B2-1:

This scenario variation consists of a single, fully-networked UUV 15 nm ahead of the Blue SAG and moving at four knots with a 15 nm sensor range. Blue SAG assets are able to employ on remote tracks provided by the UUV.

2025 B2-1:

This scenario variation involves the utilization of a prepositioned underwater sensor network by the Blue Forces. Sensor nodes for the network are assumed to have an individual detection range of 40 nm and are placed within 15 nm of each other.

E. PYTHON SCRIPTS FOR BATCH PROCESSING OF EADSIM OUTPUTS

In order to characterize the simulation based on a variable inputs, an automated script was created to modify the XML file that holds the simulation parameters before each call to run the simulation in EADSIM. The script shown in Table B.7 manipulates the weapon range before each simulation run and saves it to the output log files into corresponding directories.

Table B.7. Python Scripts for EADSIM Output Processing

```
#!/usr/bin/python
import subprocess
import lxml.etree as ET
import numpy as np
import os

tree = ET.parse('weapon.elemx')

root = tree.getroot()

for weapRange in np.arange(400000, 50000, -50000):

    directory = 'C:/Users/Ng/Downloads/code/range' + str(weapRange)
    os.makedirs(directory)

    for i in root[1].findall('Weapon'):
        if i.find('WeaponID').text == 'YJ-12':
            print i.find('WeaponID').text
            i.find('FlightCharacteristics').find('MaximumRange').text
= \
            str(weapRange)
            for j in i.find('PlanningConstraints'
                            ).find('LaunchConstraints'
                                    ).find('Air-to-AirLaunchEnvelope'
                                            ).find('OneDValues').findall('ParamValue'):
                j.text = str(weapRange)

tree.write('C:/Users/Ng/Downloads/code/trunk/elements/default/weapon.e
lemx'
          , xml_declaration=True, method='xml',
          encoding='iso-8859-1')

subprocess.call([
    'C:/eadsim_v18.00/execute/x64/eadsim.exe',
    'SEA21A_2025_NatunaBesar',
    '-dC:/Users/Ng/Downloads/code/trunk/',
    '-r "~C:/eadsim_v18.00/execute/x64"',
    '-o' + directory,
    '-R',
    ])

```

After the simulation was complete, a script was required to extract the necessary information from the log files. As the log files can get very large in size (up to 600 MB), it is not possible to view the log files using typical text viewing software. Moreover, it would be an insurmountable task to perform manually. Table B.8 shows the script necessary to

extract the kill information for the ships participating in the simulation. The extracted data is then stored in an Excel comma delimited file for loss ratio analysis.

Table B.8. Script for Extracting Kill Information from Simulated Ships

```
#!/usr/bin/python
import re
import sys
import os

with open('../data.csv', 'w') as csv:
    csv.write('Number of deaths\n')
    csv.write('Luyang,F18,Zumwalt,LCS\n')
    for logs in os.listdir('.')[1:]:
        kills = []
        with open(logs) as f:
            for line in f:
                match = re.match(r'\s+(.) exit: killed by.*at
time.*',
                                line)
                if match:
                    kills.append(match.groups()[0])

    regex = [r'Luyang', r'BlueNatunaF18', r'Zumwalt', r'LCS']
    killdict = {
        regex[0]: 0,
        regex[1]: 0,
        regex[2]: 0,
        regex[3]: 0,
    }
    for kill in kills:
        for chk in regex:
            if re.match(chk, kill):
                killdict[chk] += 1

    for chk in regex[:-1]:
        csv.write(str(killdict[chk]) + ',')
    csv.write(str(killdict[regex[-1]]) + '\n')
```

APPENDIX C. UAV TECHNOLOGY ANALYSIS

As presented in Chapter IX of this project report, the UAV candidate architecture was determined by the SEA-21A project team to be the preferred option for executing the surface-based OTHT mission in the 2025–2030 timeframe. This appendix captures the existing maritime-based UAV systems and capabilities that were leveraged in SEA-21A’s architectural analysis and identifies strengths, weaknesses, and the future growth potential for U.S. Navy ship-borne UAV solutions.

Many of the component technologies involved in today’s maritime-based reconnaissance UAVs have matured over the years and are well understood by both industry and the U.S. Navy. However, to be effective in the 2025–2030 timeframe, many of these technologies and capabilities must mature. Several existing UAVs are presented in the paragraphs that follow, to include a discussion of the various technologies that each have demonstrated by 2015. Additionally, their general capabilities, strengths, and weaknesses are also addressed.

A. CURRENT UAV PLATFORMS

1. Boeing Insitu ScanEagle

The Boeing ScanEagle, depicted in Figure C.1 is the quintessential maritime reconnaissance drone. Introduced by the Insitu Group (a subsidiary of the Boeing Corporation) in 2004, it is a fixed wing, autonomous unmanned aircraft (IHS 2015b). Initially designed to track schools of fish, it is capable of reconnoitering large areas of water. A catapult system is used to launch the aircraft into the air, and once it has autonomously completed its transit to the specific area of interest, it begins to capture images of the area using its sensor payload as dictated by its user/controller. When its mission is complete, ScanEagle autonomously navigates back to the ship and is recovered using a skyhook recovery system.



Figure C.1. Boeing Insitu ScanEagle (from IHS 2015b)

Its strengths include 24-hour endurance, gyro-stabilized sensors, and an expeditionary capability (IHS 2015b). Its significant weaknesses include the logistics and manpower footprint required to operate from U.S. Navy ships, and its relatively slow top speed of only 80 knots. This UAV system's relatively small size (and, therefore, slower speed) limits the necessary communications and sensor payload capabilities required of the SEA-21A OTHT SoS.

The platform has since evolved to the ScanEagle 2, a significant upgrade to the original aircraft. It generally features architectural and design improvements, such as an Ethernet-based architecture that enables modular payloads, to be installed depending on the required mission. Of note, the ScanEagle UAV system is widely proliferated and serves in a worldwide capacity supporting a variety of maritime and over-land missions.

2. Boeing RQ-21A Blackjack

The RQ-21 Blackjack shown in Figure C.2 is a successor to the ScanEagle. Also built by the Boeing Corporation, it is designed to fulfill the Navy/Marine Corps Small Tactical Unmanned Aircraft System (STUAS) capability (IHS 2015c). When compared to the ScanEagle, the Blackjack is better integrated into the ships it supports. This is largely due to the benefits of applying lessons learned from previous ScanEagle operations and the fact that the Blackjack was specifically designed to operate from the flight decks of U.S.

Navy CGs, DDGs, and amphibious assault ships. Each Blackjack system consists of five aircraft and a control station, with the control station capable of controlling each of the five UAVs. It has a highly modular payload bay that allows it to rapidly tailor its capabilities and mission set to the user's needs.



Figure C.2. Boeing RQ-21 Blackjack (from HIS 2015c)

The Blackjack can also provide more power for its mission systems – 350 W as compared to only 150 in the ScanEagle 2 (IHS 2015b). The flight characteristics remain very similar to the ScanEagle, and its architectural and internal system improvements provide a leap forward in capability for the U.S. Navy's surface fleet. However, its small size and slower speed still limit the Blackjack's ability to transit long distances quickly while carrying a sophisticated communications and sensors payload. Just as in the case of the ScanEagle, such a limitation impacted the Blackjack's applicability to the SEA-21A SoS.

3. Northrop Grumman MQ-8B Fire Scout

The Northrop Grumman Corporation's MQ-8B Fire Scout depicted in Figure C.3 is essentially an autonomous helicopter. It is currently in limited operational use on some U.S. Navy destroyers and cruisers. The Fire Scout B successfully integrates into existing flight decks and helicopter support architectures. While its helicopter design and associated

vertical takeoff and landing allow Fire Scout B to be easily integrated into current and future U.S. Navy surface combatants, this rotary wing configuration limits the UAVs cruising speed to 85 knots (IHS 2015d). Despite its slower speed, the Fire Scout B's sensor payload can be quickly reconfigured to adjust to emerging mission requirements – making flexibility one of its most valuable attributes for the future.



Figure C.3. MQ-8B Fire Scout (from Northrop Grumman 2015b)

The Fire Scout B's substantially larger size compared to the ScanEagle and Blackjack UAVs permits a greater payload of roughly 600 lbs, offering this UAV the option of carrying a robust sensor suite (IHS 2015d). However, much like the ScanEagle, it is not deployable without a team of contractor support personnel. While this limitation currently impacts Fire Scout B's ability to quickly integrate into the U.S. Navy surface fleet due to this additional underway manning requirement, it is likely to subside as the UAV system matures and identified active duty maintenance and support personnel can be trained. Though Fire Scout B offers a substantially improved payload over the smaller ScanEagle and Blackjack, its slow speed still greatly influenced its consideration for use in the SEA-21A SoS.

4. Northrop Grumman MQ-8C Fire Scout

The MQ-8C pictured in Figure C.4 is very similar to the MQ-8B, however it is based on an existing, proven airframe. The Fire Scout C utilizes the commercially mature Bell 407 airframe that has been in service for decades. This aspect alone eliminates much of structural and mechanical life expectancy concerns while also mitigating the supply and logistical concerns that come with a UAV platform that utilizes an otherwise unproven airframe. Fire Scout C's use of an existing airframe also takes advantage of long developed learning curves with respect to manufacturing, operations, and support.



Figure C.4. MQ-8C Fire Scout (from Northrop Grumman 2015c)

Due to its substantially larger size, Fire Scout C is capable of carrying much greater communication, sensor, and weapon payloads of up to 1000 lbs and a max speed of nearly 130 kts (Northrop Grumman 2015a). Northrop Grumman anticipates that it will fulfill both a combat and logistical supply role for the ships it serves, thereby reducing typical U.S. Navy surface combatants' dependence on a manned Sikorsky SH-60 detachment for these mission sets. While Fire Scout C provides both a greater payload and much improved speed compared to the previous three UAVs discussed, its larger size and rotary wing design

present a much greater radar cross-section (RCS) to an adversary's air search radar. Though this fact makes Fire Scout C more vulnerable to attack at close-in ranges, its ability to quickly transit long distances while carrying a substantial payload made it a favorable UAV system option for the SEA-21A SoS.

5. Saab Skeldar V-200

The Skeldar V-200 depicted in Figure C.5 is quite similar to the Fire Scout B with respect to its capabilities. It is designed and manufactured by Saab for commercial and military customers worldwide.



Figure C.5. Saab Skeldar V-200 (from Saab 2015)

While smaller than the Fire Scout B, it is a very well designed airframe that can quickly integrate into a ship's existing architecture. Its small size, however, limits its range to a mere 54 nm (Saab 2015). This makes the Skeldar incapable of flight beyond most conventional ship-based surface search radar horizons. The Skeldar's limited payload capacity of 66 lbs and low maximum speed of 70 kts makes it more suitable to close-in maritime ISR and security operations. While this UAV is not well suited for consideration in SEA-21A's OTHT study, it does possess excellent stealth and sensor capabilities despite its limited range.

6. Schiebel Camcopter

The Camcopter shown in Figure C.6 is a small multipurpose helicopter UAV. Produced by the Austrian company Schiebel, it is in service around the world in both military and non-defense related roles. The Camcopter UAV has been in service since 2004 and is a very proven airframe (OldSailor 2008).



Figure C.6. Schiebel Camcopter (from OldSailor 2008)

Similar to the ScanEagle, Blackjack, and Skeldar, the Camcopter's small size limits its usefulness in an OTHT scenario, such as the one in this study. However, its current technological maturity does present a solid opportunity for future growth. The Camcopter has a minimal logistics footprint, is simple to use, and often less expensive than other helicopter UAVs. It can support highly capable sensor suites due to its payload capacity of 110 lbs when compared to its zero fuel weight of 240 lbs. It can also provide up to 500 W of power to those sensors – an impressive figure considering the Camcopter's small size.

7. Northrop Grumman X-47B

The Northrop Grumman Corporation's X-47B pictured in Figure C.7 is a carrier launched UAV primarily designed to be a technology demonstrator. The fact that it is a carrier-based platform prohibits X-47B's consideration in SEA-21A's study due to the project team's assumption that the adversary's use of advance A2/AD techniques will preclude the use of an aircraft carrier and its embarked air wing.



Figure C.7. Northrop Grumman X-47B (from Gannett-cdn.com 2015)

Despite its inapplicability in this study, the X-47B represents significant progress in UAV automation and human-machine interactions. While it cannot operate from smaller U.S. Navy surface combatants, such as DDGs/CGs/FFs, the X-47B is notable because the lessons learned from its development will undoubtedly be leveraged in the design of smaller maritime-based UAVs.

The X-47B's demonstrated carrier integration capability implies that UAVs of the future will likely possess autonomy and seamless human-machine interaction on a similar, if not larger, scale. The X-47B also represents the first step for UAVs in carrier-based flight operations integration. As the X-47B and its associated technologies continue to mature, it

will certainly shape the development of future UAVs and enable advanced OTHT missions of the future.

B. CURRENT UAV TECHNOLOGY STRENGTHS

As evidenced by the UAVs in service today, several component technologies have demonstrated significant levels of maturity. These technologies serve as a baseline for future UAVs to build upon while helping to develop the necessary capabilities demanded of OTHT scenarios, such as the one described in this study.

1. Autonomous Flight

Every UAV listed in this appendix is capable of autonomously taking off, conducting a mission, and landing. This capability enables personnel with no flight training to successfully operate and employ these UAVs. Such technological maturity enables the UAVs to compensate for atmospheric changes in flight as they takeoff, fly, and land on their own while their host ship is underway. If such a capability did not exist for these UAV platforms at sea, their operation would almost certainly require a qualified pilot and/or sensor operator embarked on the host ship. This would result in increased manning, training, and support costs, while also affecting the available space and resources on the ship itself. Additional hardware would be required on both the UAVs and their host ships, thereby increasing costs while decreasing capabilities. Autonomous flight, particularly as it applies to underway takeoffs and landings, is a significant UAV technology strength in facilitating the OTHT mission investigated in this study.

2. Sensor Capabilities

Many sensors have been successfully miniaturized for installation and operation on multiple UAV platforms. Advancements in electro-optical infrared (EO/IR), synthetic aperture radar (SAR), and improved synthetic aperture radar (ISAR) technologies have been incorporated into various UAV sensor suites along with video stabilization to enhance the extended-range situational awareness of both ship and land-based sensors. Such sensor improvements are the product of many years' hard work and lessons learned, and their

benefits provide invaluable intelligence in the form of raw data and images that analysts and operational commanders alike can use to make time-critical decisions.

As the commercial world continues to improve and miniaturize computers and their associated components, the sensors employed by military UAVs will follow suit. Additionally, employing modular designs similar to those utilized in LCS/FF platforms will provide added benefits in the long-run as these sensor technologies become more readily available and mature.

3. Human and Crew Interoperability

Modern day UAVs are becoming increasingly capable of participating in missions just as much as their human counterparts. While this capability is by no means fully mature, the strides made thus far demonstrate that such technology will become commonplace in the very near future. This will likely eliminate the need to employ specialized aviation and contract maintenance personnel on host ships in order to operate UAVs. If this pace of improvement continues, it is likely that existing crewmembers on U.S. Navy ships will be capable of operating UAVs with minimal training.

4. Security

LOS and satellite communications technologies have matured over the past several decades and are in use by nearly every military platform in service today. All of them possess multiple transmit and receive modes that can be relied upon to facilitate secure, uninterrupted voice and data transmissions. In the modern world, UAV users need not worry about their communications being intercepted or classified data compromised should an adversary capture their UAV. This security is essential to operating any such remotely operated vehicle in a contested area where losses are likely to occur. Any UAV that the U.S. military employs should be designed such that it can be captured with little to no risk to data or how it is collected.

C. CURRENT WEAKNESSES

1. Range

The fact that the UAVs listed in this appendix are operating from relatively smaller ships means that the vehicles themselves must be small, as well. This tends to limit their maximum operational range. It has been shown in Chapter VIII of this report that there is a direct relationship between a UAV's size and long-range capability. Generally speaking, the smaller the UAV, the smaller its range and available payload. Another factor influencing a UAV's range is its vulnerability. A smaller UAV has a smaller chance of being detected (and intercepted) due to a reduced RCS compared to that of larger UAVs. While an important attribute to any airborne platform, the RCS advantage of a smaller UAV does not offset its limited range.

For example, the X-47B is capable of operating up to 2,100 nm from the aircraft carrier by taking advantage of its aerial refueling capability (Northrop Grumman 2015d). The next longest range UAV of those presented in this appendix is the MQ-8 Fire Scout C. It boasts a range of over 1,200 nm, but is a much larger platform compared to the Fire Scout B, ScanEagle, and Blackjack. As technology continues to mature and sensor suites are packaged into smaller and smaller payloads, the small (or micro) UAVs of the future will need to be capable of far greater ranges if they are to be considered viable OTHT platforms.

2. Speed

The analysis performed by SEA-21A in this study demonstrated that the speed of the UAV is an important factor in the time required to detect, classify, and engage an adversary ship within a specified AOU. An organic UAV capable of transit airspeeds in excess of 110 kts enables a U.S. Navy surface combatant to greatly reduce the time required to employ a weapon against an adversary ship at maximum engagement range. At distances of 300 nm and greater, even small improvements in a UAV's transit speed have a large impact on the time required to complete the F2T2EA kill chain. Speed improvements for

such smaller maritime-based UAV systems will require significant advances in propulsion along with reduced component and airframe weights.

3. Logistics

Current maritime-based UAVs tend to require contractor personnel and significant amounts of support equipment to be deployed on the ship from which they operate. This is primarily due to the fact that implementing UAV systems on U.S. Navy surface combatants is a relatively young and unproven concept. Additionally, U.S. Navy surface combatants are typically far removed from typical lines of rapid logistical support, thus necessitating additional support equipment to be deployed with the UAV system.

Unfortunately, such requirements detract from other host ship mission sets and capabilities. Future UAVs must not only be capable of being operated and maintained by the host ship's existing crew, they must also be capable of operating without disrupting the host ship's other mission areas. This is a significant hurdle for maritime-based UAV development, for sure. Eventually, however, embarked personnel must be capable of seamlessly operating these organic UAVs that are likely to possess modular sensor packages, tailored to the needs of an evolving mission. This will place a significant burden on training designated personnel on the ships from which the UAVs are embarked.

4. Integration

Integration with respect to a ship's combat and computer systems is also a future challenge for maritime-based UAV systems. The network and hardware architectures on U.S. Navy surface combatants must be capable of operating current systems while remaining flexible enough to both integrate and operate the rapidly evolving technologies and capabilities associated with today's UAVs. This will enable SAGs to fully exploit the UAV capabilities of the future in the prosecution of targets that lie well beyond the radar horizon.

By the same token, UAVs must be designed with a ship's environment in mind. This will require the development of specific and well thought out integration and risk

mitigation plans between the U.S. Navy and the corporations producing the UAVs. This will also be a particularly difficult challenge as it will require much collaboration in the design, development, and procurement of both the operational and supports systems required of maritime-based UAVs.

D. CONCLUSION

Clearly, UAVs have a promising and exciting future in the U.S. Navy, particularly as they apply to extending the capabilities of the surface fleet. It is evident that as sensor, propulsion, and launch and recovery technologies evolve, maritime-based UAVs will become even more capable. While much of the focus on UAV employment at sea has been centered on ISR and surface-based OTH power projection, it is likely that UAV mission areas will also expand to those of logistics, HA/DR, and search and rescue. While many challenges exist with respect to UAVs' successful implementation at sea, the potential long-term benefits greatly outweigh the short-term costs, and the U.S. Navy is likely to see greatly expanded capabilities in multiple mission sets through their use.

THIS PAGE INTENTIONALLY LEFT BLANK

LIST OF REFERENCES

- Autonomous Undersea Vehicle Application Center (AUVAC). 2011. "Where Data Depend on Catching a Wave." July 7. <http://auvac.org/newsitems/view/1113>.
- BAE Systems. 2015. "155-mm Long Range Land Attack Projectile (LRLAP)." Accessed May 19. http://www.baesystems.com/product/BAES_020036/155-mm-long-range-land-attack-projectile-lrlap;baeSessionId=oF_vLqJdJDgv7gSchkDVLng7PX7LuNLtsHU-mbfAySEqr8mPPQDv!-1477725154?_afrLoop=2509683153245000&_afrWindowMode=0&_afrWindowId=null#!%40%40%3F_afrWindowId%3Dnull%26_afrLoop%3D2509683153245000%26_afrWindowMode%3D0%26_adf.ctrl-state%3D1c96dvumb1_4.
- Blanchard, Benjamin S., and Wolter J. Fabrycky. 2010. *Systems Engineering and Analysis*. 5th ed. Upper Saddle River, NJ: Prentice Hall.
- Buede, Dennis. 2009. *The Engineering Design of Systems*. Hoboken, NJ: John Wiley & Sons.
- Canavan, Greg. 2004. *Estimates of Performance and Cost for Boost Phase Intercept*. Washington, DC: The George Marshall Institute.
- Clark, Vern. 2002. *Sea Power 21: Projecting Decisive Joint Capabilities*. Annapolis, MD: Naval Institute Press.
- Dawn Breaker Phase III Portal. 2013. "OPNAV 9." <http://www.dawnbreaker.com/portals/phase3/opnav-resource-sponsors/opnav-n9/>.
- Defense Acquisition University. 2004. "Chapter 4: Systems Engineering." In *Defense Acquisition Guidebook*. Fort Belvoir, VA: Defense Acquisition University Press.
- Defense Acquisition University. 2012. *Glossary of Defense Acquisition Acronyms and Terms*. Fort Belvoir, VA: Defense Acquisition University Press.
- Defense Logistics Agency (DLA). 2015. "FY2015 Standard Fuel Prices." Accessed May 8. http://www.energy.dla.mil/DLA_finance_energy/Pages/dlafp03.aspx.
- Defense Update. 2014. "Aberdeen Based Aerostat in Position to Protect Washington from Cruise Missile Attack." http://defense-update.com/20141227_jlens_over_maryland.html#.VUj0edNViko.
- Department of Defense (DOD). 2004. *Defense Acquisition Guidebook Ch. 4 "System of Systems Engineering"*. Washington, DC: Pentagon.
- Department of Defense. 1992. *DOD Cost Analysis Guidance and Procedures*. DOD 5000.04-M. Washington, DC: Department of Defense.

Department of the Army. 2003. *Test and Evaluation in Support of Systems Acquisition*. Army Regulation 73-1. Washington, DC: Headquarters Department of the Army.

Gannett-cdn.com. 2015. "X-47B Refuel." April 17. <http://www.gannett-cdn.com/-mm-/e8fcb8aea212a5429cde618786a37005efbfc430/c=0-151-2046-1307&r=x633&c=1200x630/local/-/media/2015/04/17/GGM/MilitaryTimes/635648815689900493-NAV-X-47B-refueling-droque.JPG>.

Gilmore, Lance, and John Valaika. 1992. *Operating and Support Cost-Estimating Guide*. Washington, DC: Office of the Secretary of Defense, Cost Analysis Improvement Group.

Global Security Org. 2014. "WU-14 Dong Feng-21D (DF-21D)/CSS-5 Mod 5 Anti-Ship Ballistic Missile (ASBM)." Last modified April 12. <http://www.globalsecurity.org/wmd/world/china/df-21d.htm>.

Google Maps. 2015. "South China Sea and Natuna Besar." Accessed May 21. <https://www.google.com/maps/@4.3734904,108.8022953,1313078m/data=!3m1!1e3?hl=en>.

Hagel, Chuck. 2014. *Quadrennial Defense Review*. Washington, DC: Department of Defense.

Honegger, Barbara. 2011. "NPS Pioneers "Seaweb" Underwater Sensor Network." *Undersea Warfare* 45. http://www.public.navy.mil/subfor/underseawarfare/magazine/issues/archives/issue_45/seaweb.html.

IHS. 2015a. *Arleigh Burke (Flights I and II) Class*. Englewood, CO: IHS.

IHS. 2015b. *Boeing-Insitu ScanEagle*. Englewood, CO: IHS.

IHS. 2015c. *Insitu RQ-21A Blackjack*. Englewood, CO: IHS.

IHS. 2015d. *Northrop Grumman RQ-8A and MQ-8B Fire Scout*. Englewood, CO: IHS.

Imagine That Inc. 2013. *ExtendSim 9 User Guide*. San Jose, CA: Imagine That Inc.

International Organization for Standardization/Institute of Electrical and Electronics Engineers/International Engineering Consortium. 2010. "ISO/IEC/IEEE 24765:2010(en), Systems and Software Engineering—Vocabulary." <https://www.iso.org/obp/ui/#iso:std:iso-iec-ieee:24765:ed-1:v1:en>.

Isodori, A., J. H. van Schuppen, E. D. Sontag, and M. Krstic. 1997. "Communications and Control Engineering Series." In *Identification of Parametric Models*, edited by Eric Walter and Luc Pronzato. London: Springer-Verlag.

- Jinhai, L. F. 2014. *Analysis on the Spatial Distribution Characteristics of Maritime Traffic Profile in the Western Taiwan Strait*. Beijing: Institute of Geographic Sciences and Natural Resources Research.
- Joint Chiefs of Staff. 2007. *Joint Targeting*. Washington, DC: Joint Chiefs of Staff.
- Kline, Jeffrey. 2014. "FY2015 SEA21 Capstone Projects: Tasking and Timelines." Memorandum, Naval Postgraduate School.
- LaGrone, Sam. 2015. "WEST: Bob Work Call Navy's Anti-Surface Tomahawk Test 'Game Changing.'" USNI News. February 10. <http://news.usni.org/2015/02/10/west-bob-work-calls-navys-anti-surface-tomahawk-test-game-changing>.
- Liquid Robotics. 2014. "Wave Glide SV-3." <http://liquidr.com/technology/waveglider/sv3.html>.
- Maier, Mark W., and Eberhardt Rechtin. 2009. *The Art of Systems Architecting*. 3rd ed. Boca Raton, FL: CRC Press, Taylor & Francis Group.
- Marine Traffic. 2015. "Live Ships Map—AIS—Vessel Traffic and Positions—AIS Marine Traffic." Accessed May 1. <http://www.marinetraffic.com/en/ais/home/centerx:106/centery:2/zoom:7>.
- Merriam-Webster. 2015. "System." Accessed March 10. <http://www.merriam-webster.com/dictionary/system>.
- MITRE. 2013. "Develop System-Level Technical Requirements." September. <http://www.mitre.org/publications/systems-engineering-guide/se-lifecycle-building-blocks/system-design-and-development/develop-systemlevel-technical-requirements>.
- Mullen, Michael G. 2011. *The National Military Strategy of the United States of America, 2011 Redefining America's Military Leadership*. Washington, DC: Joint Chiefs of Staff.
- National Geospatial Intelligence Agency. 2006. "NGA Raster Roam." Last updated February 6. http://geoengine.nga.mil/muse-cgi-bin/rast_roam.cgi.
- NOAA Center for Tsunami Research. 2015. "DART Deep-ocean Assessment and Reporting of Tsunamis." Accessed April 24. <http://nctr.pmel.noaa.gov/Dart/>.
- Northrop Grumman. 2015a. "Fire Scout." Accessed June 14. <http://www.northropgrumman.com/Capabilities/firescout/Pages/default.aspx>.
- Northrop Grumman. 2015b. "MQ-8B Fire Scout." Accessed May 25. http://www.northropgrumman.com/Capabilities/MQ8BFireScout/PublishingImages/ss_MQ-10027_001_734x265.jpg.

- Northrop Grumman. 2015c. "MQ-8C Scout." Accessed June 13. http://www.northropgrumman.com/MediaResources/Pages/Photo.aspx?pid%3DMQ-10027_029%26rel%3D%2F%26name%3DPhotos.
- Northrop Grumman. 2015d. "X-47B UCAS Makes Aviation History...Again!" Accessed June 14. <http://www.northropgrumman.com/Capabilities/X47BUCAS/Pages/default.aspx>.
- NPS CRUSER. 2014. "About." <http://my.nps.edu/web/cruser/about>.
- Office of the Chief of Naval Operations. 2014. "OPNAV Organization." Accessed December 11. <http://www.navy.mil/navydata/organization/org-cno.asp>.
- OldSailor. 2008. "Schiebel Camcopter S-100 Completes Sea Trials in German Navy." <http://www.marinebuzz.com>.
- Patt, Daniel. 2014. *Tactically Exploited Reconnaissance Node (TERN)*. Arlington, VA: DARPA Tactical Technology Office. http://www.darpa.mil/Our_Work/TTO/Programs/Tactically_Exploited_Reconnaissance_Node_%28TERN%29.aspx
- Project Performance International. 2011. "Systems Engineering Newsletter (SyEN) SyEN#36." Sep 27. <http://www.ppi-int.com/newsletter/SyEN-036.pdf>.
- Rice, Joseph, and Dale Green. 2008. "Underwater Acoustic Communications and Networks for the U.S. Navy's Seaweb Program." 2008 Second International Conference on Sensor Technologies and Applications (SensorComm 2008). http://ieeexplore.ieee.org/xpls/abs_all.jsp?arnumber=4622745&tag=1.
- Rowden, Thomas, Peter Gumataotao, and Peter Fanta. 2015. "Distributed Lethality—The Beginning of the Beginning." *Proceedings* 141(1): 18–23. <http://www.usni.org/magazines/proceedings/2015-01/distributed-lethality>.
- Saab. 2015. "Skeldar V-200 Maritime." Accessed May 23. <http://saab.com/air/airborne-solutions/unmanned-aerial-systems/skeldar-v-200-maritime/>.
- Software and Systems Engineering Vocabulary: SEVOCAB. 2015. "Search Results." Accessed March 11. http://pascal.computer.org/sev_display/search.action.
- Teledyne Brown Engineering Inc. 2005. "EADSIM Overview." Last updated January 26. <http://www.eadsim.com/overview.asp>.
- Truver, Scott. 2006. "The Art of the Possible Communications at Speed and Depth." *Undersea Warfare* 8(3). http://www.navy.mil/navydata/cno/n87/usw/issue_30/art.html.
- U.S. Air Force. 1998. *USAF Intelligence Targeting Guide. Air Force Pamphlet 14-210 Intelligence*. Washington, DC: U.S. Air Force.

- U.S. Navy. 2015. "NWDC." Accessed February 14. <http://www.navy.mil/local/nwdc/index.asp>.
- U.S. Pacific Fleet. 2014. "About the U.S. Pacific Fleet." Accessed December 10. <http://www.cpf.navy.mil/about/>.
- Vego, Milan. 2009. "Part III: Operational Factors: The Factor of Space." In *Joint Operation Warfare*, edited by Milan Vego, III-7–III-17. Reprint. Newport, RI: Naval War College.
- Walker, Dustin. 2013. "Navy Chief Impatient to Avoid Being Out-Sticked." RealClearDefense. November 19. http://www.realcleardefense.com/articles/2013/11/19/navy_chief_impatient_to_avoid_being_out-sticked_106966.html.
- Washburn, Alan R. 2002. *Search and Detection*. Baltimore: Military Applications Section, Operations Research Society of America.
- White House. 2015. *National Security Strategy*. Washington, DC: Office of the President of the United States.

THIS PAGE INTENTIONALLY LEFT BLANK

INITIAL DISTRIBUTION LIST

1. Defense Technical Information Center
Ft. Belvoir, Virginia
2. Dudley Knox Library
Naval Postgraduate School
Monterey, California