



2004

# Process Modeling: A Systems Engineering Tool for Analyzing Complex Systems

Osmundson, John S.

---

Systems Engineering, Vol. 7, No. 4, 2004  
<http://hdl.handle.net/10945/44175>



Calhoun is a project of the Dudley Knox Library at NPS, furthering the precepts and goals of open government and government transparency. All information contained herein has been approved for release by the NPS Public Affairs Officer.

**Dudley Knox Library / Naval Postgraduate School  
411 Dyer Road / 1 University Circle  
Monterey, California USA 93943**

# Process Modeling: A Systems Engineering Tool for Analyzing Complex Systems

John S. Osmundson,<sup>1,\*</sup> Russell Gottfried,<sup>2</sup> Chee Yang Kum,<sup>3</sup> Lau Hui Boon,<sup>4</sup> Lim Wei Lian,<sup>4</sup>

Poh Seng Wee Patrick,<sup>3</sup> and Tan Choo Thye<sup>4</sup>

<sup>1</sup>Departments of Information Sciences and Systems Engineering, Naval Postgraduate School, 1 University Circle, Monterey, CA 93943-5000

<sup>2</sup>Department of Operations Research, Naval Postgraduate School, 1 University Circle, Monterey, CA 93943-5000

<sup>3</sup>Republic of Singapore Navy, Republic of Singapore

<sup>4</sup>Singapore Armed Forces, Republic of Singapore

Received 18 March 2004; Accepted 28 June 2004, after one or more revisions

Published online in Wiley InterScience (www.interscience.wiley.com).

DOI 10.1002/sys.20012

## ABSTRACT

This paper presents a method for performing architectural analyses of complex systems-of-systems using process modeling. A process is a series of actions undertaken by a system-of-systems to produce one or more end results, typically products and services. The method applies to systems-of systems whose effectiveness and performance depend strongly on process timelines, such as distributed information systems, logistics systems, and manufacturing and distribution systems. A fundamental tool in this method is the development of a unified modeling language (UML) related view of the system-of-system processes of interest and the subsequent conversion of the UML related view into an end-to-end system-of-systems executable object-oriented simulation model. This method is illustrated by applying

---

\*Author to whom all correspondence should be addressed (e-mail: josmundson@nps.edu).

Systems Engineering, Vol. 7, No. 4, 2004

© 2004 Wiley Periodicals, Inc.† This article is a US Government work, and, as such, is in the public domain in the United States of America.

process modeling and simulation to analysis of a military systems-of-systems, an expeditionary warfare system envisioned for the 2015–2020 time frame. Expeditionary warfare is the operation of an armed force in an area far from a supportable home base and supported by temporarily established means. The U.S. military has conducted expeditionary warfare in the past by building up forces, equipment, and supplies at a beachhead before moving on to an objective. There is current interest in the U.S. military to shift from the concept of establishing a beachhead and then movement to an objective to a concept of sea-based launching and supporting forces and sea-to-objective maneuver for fighting forces. A fundamental tool in this analysis is an end-to-end object-oriented simulation model emulating the full implementation of these force architectures and design factors as well as accounting for the impact of varying levels of operational intensity, attrition of personnel and transport vehicles, weather, mining sea lanes, transport vehicle operating and availability constraints, landing spot constraints, and transit and communications delays. This paper focuses on the framework of the simulation model and its most significant findings as applied to expeditionary warfare concepts as an example of the application of process modeling to architectural analyses of complex systems-of-systems. © 2004 Wiley Periodicals, Inc.† Syst Eng 7: 320–337, 2004

Key words: process modeling; systems of systems analysis; modeling and simulation

## 1. INTRODUCTION

Systems-of-systems use processes—a series of actions undertaken to produce products, services, or other end results. A challenge in systems engineering is to analyze existing and proposed systems-of-systems architectures. Architectural analyses of complex systems-of-systems, therefore, often involve analyses of systems processes, with the goals of identifying the most important process design parameters that affect system performance and understanding the sensitivity of system performance to variations in the driving design parameters. An understanding of system processes is especially important when analyzing complex systems-of-systems whose performance depends strongly on process timelines. Figure 1 shows an illustration of a generic system-of-systems and interactions between system

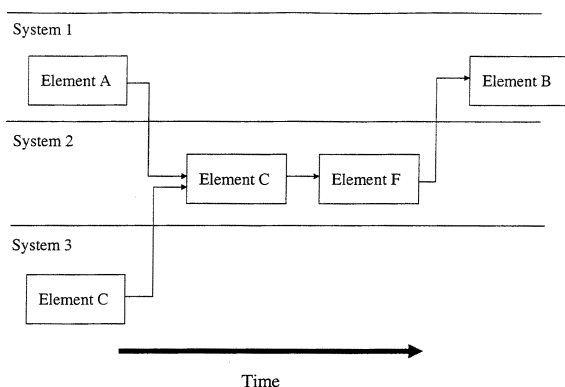

**Figure 1.** Graphical view of system-of-systems interactions in a UML format.

elements, with time increasing to the right along the horizontal axis. As illustrated in Figure 1, element A of system 1 and element C of system 3 interact with system 2 by passing physical items or information to element C of system 2. Later element F of system 2 interacts with element B of system 1. Examples of elements of systems could include organizations of people, processing systems, communication systems, production systems, or transportation systems that interact to produce information, products or to transport things.

The flow of interactions shown on Figure 1 from a starting point to a logical ending point is similar to a thread in a software system, and this view of system-of-system interactions is analogous to swim lane diagrams in the Unified Modeling Language (UML) [Larman, 1998]. Complex system interactions can be understood by modeling each system in terms of objects corresponding to system elements, with the proper logical flow and timing of items of interest passed between system elements, either within a system boundary or across system boundaries, during interactions. Passing of items from one model object to another is analogous to passing messages between objects in UML. The measures of performance of such systems-of-systems could include time to complete a thread—such as accomplishing a complex task or the throughput of items through the total system. Depending on how the model is constructed another example of a measure of performance could be the quality of the final outputs.

The goal of some architectural analyses might be to determine interoperability requirements between systems. In an information system, for example, the directed arrows on Figure 1 would be information items

and the graphical view of the system would indicate information exchange requirements needed for interoperability. If the graphical view shown on Figure 1, known as a “paper model,” were converted into an executable model such as a discrete event model, the timing requirements for interoperability could be determined.

One example of a process driven system-of-systems architecture in the military is a joint service intelligence collection management system. An example of a commercial system-of-systems would be the inter-operation of several organizations that join together in a new way to produce services or products.

In this paper the application of process modeling to future expeditionary warfare systems-of-systems is discussed. A short background of expeditionary warfare is given, the systems analysis approach is described, the expeditionary warfare process model is explained, and results of simulations using the expeditionary warfare model are shown. The paper concludes with some observations relating process modeling to the study of generic systems-of-systems architectures.

## 2. EXPEDITIONARY WARFARE ARCHITECTURES

In April 2002, the Deputy Chief of Naval Operations, for Warfare Requirements and Programs, directed an expeditionary warfare systems analysis by the Systems Engineering and Integration curriculum of the Wayne E. Meyer Institute of Systems Engineering at the Naval Postgraduate School. Specifically, the guidance given was that the general focus of this analysis must be on investigating systems capabilities for power projection and forcible entry. The intent of the analysis was to address as broad a scope of systems as is feasible, starting with the current programs of record as the baseline [McGinn, 2002].

According to U.S. Marine Corps (USMC) doctrine, an expeditionary force is an armed force organized to accomplish a specific mission in foreign lands, far from a supportable home base, and supported by temporarily established means (USMC, 1998b). The U.S. military has long been concerned with expeditionary warfare, developing plans during the first half of the 20th century, and then achieving important victories throughout World War II and the Korean War. However, the operational concepts behind the Navy–Marine Corps expeditionary forces of today are not much different than the ones that existed in the 1950s. Past expeditionary forces required operational pauses to build up forces in order to complete missions. Typically the buildup of forces was done at a beachhead in a process of establishing an

“iron mountain,” a term referring to the large amount of equipment and supplies built up at the beachhead. The iron mountain was essential to assembling and positioning sufficient force to then maneuver and secure the objective.

Expeditionary warfare is a concept that seeks to make full use of sea basing (USMC, 2000; Deputy Chief of Naval Operations, 2000; England, 2002). Sea basing is a concept in which forces and equipment are assembled at sea and then deployed directly to an objective without establishing a beachhead. The question is whether current and planned U.S. expeditionary warfare forces can fight and win by employing this type of warfare.

The study undertaken by NPS includes extensive research into existing and proposed expeditionary warfare subsystems and a number of supporting analytical studies. A complete report on this study is available [SEIa, 2003]. In this paper we focus on the process modeling of the overall expeditionary warfare system process.

The expeditionary operations considered for this study are assumed to take place in the year 2020 timeframe and are conducted with a Marine Expeditionary Brigade (MEB)-sized force. MEB operations are conducted up to 200 nautical miles (nm) inland from a sea base located 25–100 nm offshore. Logistics ships, Maritime Preposition Force (MPF) ships, and at least one Carrier Strike Group (CSG) will augment the assault. Legacy platforms are projected to remain operational through this timeframe. All new USMC aircraft and land vehicle purchases currently projected to be available in this timeframe are fielded on schedule.

The guidance given for the study included the direction to consider three architectures for an expeditionary warfare system: A current architecture, a planned architecture using sea-basing, and a conceptual architecture using sea-basing, more reliance on high-speed transport and use of notional sea-basing vessels. The intent was to quantify any increases in expeditionary warfare performance that could be realized with planned and conceptual architectures.

### 2.1. Current Architecture

The USMC’s current doctrine indicates that the “notional” MEB force size is about 17,000 troops, approximately 5500 of whom comprise the ground combat element that is projected ashore. The remainder is organized into an aviation combat element and a combat service support element. The amphibious force supporting a MEB expeditionary warfare operation normally consists of a Navy element consisting of a mix of amphibious ships, support ships, and in some cases maritime prepositioned assets, which carry equipment

and sustainment for fighting forces. Carrying sufficient equipment and supplies to sustain 17,000 Marine Corps personnel, six MPF ships are designed to sustain the MEB 30 days. Prepositioned amphibious and support ships are designed to reduce strategic airlift requirements and global response time.

In its current configuration, the force projects Marines ashore to the landing beaches and objective areas utilizing organic surface craft and helicopters, first establishing an iron mountain that uses existing port facilities as a base for combat force and logistics build-up. Upon establishing and securing an iron mountain site, the MPF ships pull in to unload their equipment and supplies. At the same time, the combat forces maneuver to the objective area. Commercial ships will transfer subsequent re-supplies from the continental U.S. (CONUS) or forward logistics sites to the iron mountain at regular intervals. This study assumes that MEB-sized force composition and sustainment requirements remain relatively constant between the present and the 2015–2020 timeframe. These requirements are defined in the *MAGTF Planner’s Guide* [USMC, 2001b], the *Organization of Marine Corps Forces* [USMC, 1998a], and the pamphlet, *Naval Expeditionary Warfare: Decisive Power, Global Reach* [CNO (N75), 2002]. Table I presents the daily requirements for a MEB. The force relies on five or six MPF ships to provide equipment and sustainment of one MEB for 30 days. As stated, current MPF ships require offloading cargo in a port facility and flying combat personnel into an airfield in order to “marry up” with their equipment. This offload and assembly process is expected to last 10 days.

**2.2. Planned Architecture**

The Planned Architecture is similar to the current one, with programmed replacement of units by air, land, and sea platforms scheduled to be in service during the 2015–2020 timeframe. The distinctive difference in this architecture is implementation of sea basing, integrating the MPF (Future) ships capable of providing command and control, power projection, and logistical support directly from the sea without the use of an intervening iron mountain (USMC, 1996). The fighting force, utilizing surface craft and helicopters organic to the expeditionary force, will be projected ashore to the

**Table I. Daily Sustainment Requirements for a MEB (Short Tons)**

Food	Water	Fuel	Ammunition	Other Cargo
12.53	158.86	152.23	32.07	22.21

objective area via a landing beach and then will punch through to the objective without an operational pause.

Doctrine envisions that MPF ships will form the sea base securely at sea and supply the forces ashore directly (USMC, 1997). Commercial ships or high-speed vessels will transfer subsequent resupplies from CONUS to the sea base at regular intervals. In addition to implementing the concept of operating from a sea base, the fighting force features upgrades to amphibious platforms and their capabilities in conjunction with ships and aircraft already programmed for construction or operational implementation over the next 10–15 years. The planned architecture consists of a projected large-deck amphibious assault ship replacement and the new amphibious transport ships, along with legacy ships. Surface craft, continuing to transport personnel, equipment, and supplies, have planned replacements. Finally, the MV-22 advanced rotary wing aircraft is in service for this system for use in conjunction with legacy helicopters. An assumption of this analysis is the resolution of current day MV-22 technical and operational problems.

**2.3. Conceptual Architecture**

The third expeditionary warfare architecture studied, a Conceptual Architecture, differs from the Planned Architecture, by employing significantly more MV-22 aircraft and introducing new conceptual heavy lift aircraft [SEIb, 2003], combat ships and logistic ships [SEIc, 2003] designed in related efforts in the Naval Postgraduate School study [SEIa, 2003].

**2.4. Summary**

The three architectures considered in this study are summarized in Table II. These are considered to span all of the viable options in the year 2020 time frame. Routes going from off shore bases or U.S. land areas directly to an objective are considered infeasible because of the need to transport large amounts of forces and material over very long distances, assuming expeditionary warfare scenarios of interest are usually not near off shore bases or U.S. land areas.

**Table II. Summary of Expeditionary Warfare Architectures**

Routing	Naval Transport Vehicles	Air Transport Vehicles
Seabase to Objective via Iron Mountain	Existing	Existing
Seabase Direct to Objective	Planned	Planned
Seabase Direct to Objective	Conceptual	Conceptual

### 3. SYSTEMS ANALYSIS APPROACH

An expeditionary warfare system must deliver forces and supplies to the objective in required quantities, while being designed with the properties of survivability, reliability, maintainability, and cost effectiveness in mind. The analysis of expeditionary warfare system issues requires a layered approach, identifying the most important system factors and corresponding design choices that result in the most effective system. A forcible entry scenario campaign analysis conducted as part of the overall NPS study determined the high level measures of performance for an expeditionary warfare system to be the speed with which forces can be built up at the objective and the level to which forces can be sustained once they reach the objective. These measures of performance are functions of delays in transport, packing and unpacking, and queuing delays due to competition for scarce transportation and logistics resources. This high-level analysis of emerging system of systems behavior is essential to determining performance requirements for specific subsystems.

Queuing delays are the most important component and most difficult to analyze [Bertsekas and Gallager, 1991]. Realistic analysis of queuing delays in this complex system accounts for large numbers of possible routes, logistics, and dynamic demands with varying noise conditions in which the network operates. The problem is compounded because system performance is strongly dependent on detailed timing and system interfaces. The goal of the expeditionary warfare system analysis is to resolve high-level architectural issues, enabling design engineers to later resolve issues of system detail. This allows for a layered approach, addressing top-level trades first, before lower level studies. The objective is to identify the driving issues in an expeditionary warfare system; after defining these issues, follow-on studies can address the design optimization of expeditionary warfare subsystems and components and sensitivity analysis.

A useful technique to aid in understanding the system time behavior is to construct event threads for expeditionary warfare [Osmundson, 2000]. The atomic units of this complex expeditionary warfare system consist of time delays, transportation processes, warfare activity, and interfaces among these functions. Time delays are associated with the performance of each function and interface, such as loading and unloading of troops, equipment, and supplies, as acted upon by environmental factors and combat activity, such as attrition rates or mine activity. One approach to improving system performance is to minimize the total time delay associated with each important thread of functions through the system.

In general, system latency or response time is due to item queuing, processing delay, system capacities, and transportation path delays. The expeditionary warfare model is a distributed system using network simulation tools. Simulation runs yield thread time delays, while experimentation enables system architecture variation by rearranging the model, which may yield new thread time delays. Repeating experiments to determine characteristics that yield the best system performance, the model provides insight into various configurations of the system itself, and into its robustness with respect to influences imposed by the environment in which it operates. This marks a departure from other analyses that may simply focus on expected values in pursuit of optimality.

Modern system design and analysis software applications provide the capability to model systems of time-dependent processes analogously to the method described above. System elements can be described as objects having the properties of delays, routers, switches, combiners, and other system activities. Grouping objects can represent functional properties of a system. A given modeling object can represent system functionality. These objects can be graphically linked to form a model of a distributed system of systems. Event generators trigger the creation of objects and resultant threads in the system model.

#### 3.1. System Design Factors

An initial step in the analysis process is to identify the main design factors in a conceptual expeditionary warfare system. These system design factors, or variables, are those factors under the conceptual system planners' control that can influence system performance in delivering forces and supplies to the objective destination.

In an expeditionary warfare system, the high level design factors are those that affect the speed of delivery of forces and supplies. These design factors are routing of forces and supplies, speed of transport of forces and materials (a function of payload, speed, quantity, and availability of the transport vehicles) and efficiency logistics. Routing refers to the choice of moving directly from a launch area to the objective or moving from the launch area to an intermediate location where supplies can be built up before moving to the objective. Speed of transport of forces and supplies can vary, for example, by employing relatively fast, low-payload aircraft or slow, large-payload ships. Also, the type of ship could be a conventional large payload, moderate speed ship or an advanced design ship that is much faster but carries a smaller payload. Efficiency of logistics encompasses the speed with which forces and sup-

plies can be loaded and unloaded at various points in the expeditionary warfare chain.

Cost was not considered as a design variable due to the guidance given at the start of the study. As an output of this study the U.S. Navy wanted to know whether more advanced expeditionary warfare systems architectures would yield improvements in systems performance sufficient to warrant more detailed studies that would give the basis for cost comparisons.

Varying design factors by selecting from several different states or levels yield diverse outcomes due to different combinations that represented potential system options. Comparisons give rise to conclusions based on these configurations. Trade studies of systems concepts with design factors selected in different levels yield identification of the most significant expeditionary warfare system design issues and determination of the best values for these factors.

### 3.2. Noise Factors

Discriminating between design factors among various levels of noise factors drives the level of fidelity and resolution sought in this simulation model. Simulation is able to reflect the degree of precision that mathematical programming or constraint diagrams would fail to elucidate, specifically with regard to the variability imposed by changing states of noise factors. Employing forcible entry operations on different occasions with the same environmental factors will likely yield different results.

Based on observations of amphibious and campaign analysis, modelers include weather, the extent to which sea-lanes are mined, consumption rates of ammunition and supplies, and combat attrition as noise factors in the simulation. Weather affects system performance by slowing the speed of transport and by slowing the process of loading and unloading forces and supplies. Sea mining causes delays while mine sweeping operations are carried out. Sea mining also may limit the number of sea access routes, in turn constraining the number of simultaneous sea transits by surface craft. High use of consumables, including fuel and water, increases demands on supply lines. High combat attrition creates the need for more frequent reinforcement and resupply of ammunition, water, fuel, and other essentials.

The modular approach to modeling the expeditionary warfare systems allows representation of design factors by association with modeling application objects. System options are represented by rearranging the objects and by varying the object attributes among model inputs. This approach enables comparison and

analysis of performance across the range of noise factors.

## 4. EXPEDITIONARY WARFARE MODEL

A process model needed to be developed to analyze the expeditionary warfare system architectures. An object-oriented tool best characterizes the components and processes involved with moving combat forces ashore and sustaining them. To enable a systematic and comprehensive study on expeditionary warfare and the factors that affect its performance, an end-to-end expeditionary warfare model was built with EXTEND<sup>TM</sup>, a discrete event simulation tool. This particular tool offers an ability to capture the functions, interfaces, delays, and systemic characteristics to a desired level of fidelity. The resulting model emulates the processes involved in accumulating, assembling, deploying, and sustaining expeditionary forces ashore. It provides a means for full accounting of the transport vehicles, forces, equipment, and supplies and their interactions within the system and allows studies of the dependencies of expeditionary warfare system architecture performance on design and noise factors.

A view of the expeditionary warfare system is shown in Figure 2 that corresponds to the generic process model shown in Figure 1. Figure 2 depicts the nodes involved in the entire operation and the flow of forces, equipment and supplies between the nodes. Two alternative routes are shown, one corresponding to the current use of an iron mountain and the other corresponding to the use of a sea base and transport of forces, equipment, and supplies directly to the objective from the sea base.

Due to the shift in concept from the current iron mountain-based architecture and the evolving sea-based Sea-to-Objective concept, two separate models were built.

The first model was designed specifically to depict the flow from CONUS, to include forward deployed forces forming a MEB, assembling and proceeding to the launching area. Once the MEB arrives at the launching area, forces deploy in scheduled waves to both the objective and the iron mountain. After the iron mountain is secured for a specified period of time, the first wave of logistic supplies, provided by MPF ships supplying logistics such as food, water, ammunition, and spares, arrive and build up of a logistic depot commences. Large, medium-speed ships or smaller high-speed vessels (HSV) carry out subsequent logistic supplies from the offshore base to the iron mountain. At the same time, while concurrently fighting at the objective, reinforcements continue to advance from the iron

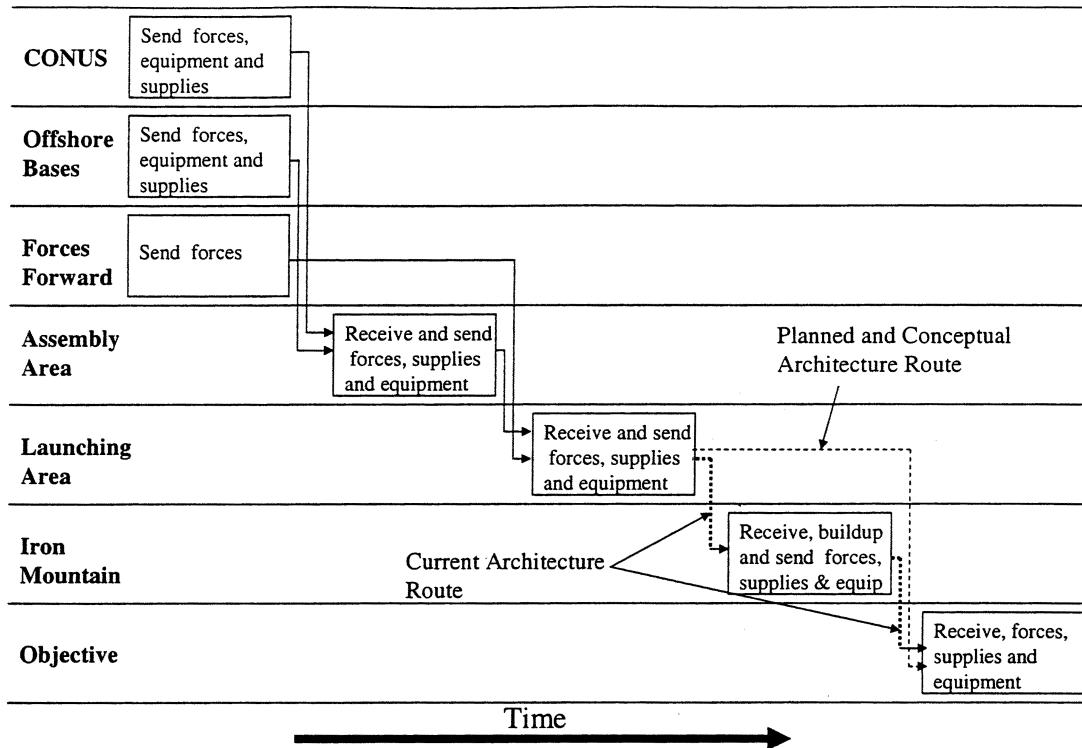

Figure 2. Expeditionary warfare depicted as a system-of-systems.

mountain to the objective, providing troops, food, water, and ammunition. For the purpose of this study, the entire operation continues for a 90-day period.

The second model emulates expeditionary processes that allow both the planned and conceptual architectures to run under the new concept of operations, eliminating the need to establish an iron mountain using a sea base to provide the logistic depot. As in the first model, this begins with the build up of an MEB-sized force from CONUS and forward-deployed forces at an assembly area and subsequent movement to the launching area. From the launching area, forces deploy in scheduled waves to the objective. After all the scheduled waves have been launched, the logistic ships stationed at the assembly area begin sustainment operations. Either large medium-speed ships or high-speed vessels transit between the offshore base and the assembly area to replenish these logistic ships. Again, the operation runs for a 90-day period. The main difference between the planned and conceptual architectures is that the assets used are different. Thus the second model represents the routing appropriate to both the planned and conceptual architectures, but different sets of parameters are used in the second model to represent the different assets in the planned and conceptual archi-

tectures. A top level view of the second EXTEND<sup>TM</sup> executable model (Fig. 3) and one example of a lower level of detail from the launching area (Fig. 4) are shown. The top level view has a one-to-one correspondence to the nodal view shown in Figure 2, with the addition of a Beach Area in the EXTEND<sup>TM</sup> model to account for equipment that is too heavy to transport by air directly to the objective. Each major element of the top level model is treated as an object with forces, equipment, supplies, and transport vehicles passed from one object to another. Each high level object is then modeled in hierarchical layers of detail.

The approach to process modeling of other systems-of-systems is similar. Analysts partition the system-of-system of interest as a collection of objects and processes that create, modify, and use items, with appropriate interactions between the objects. Interactions are passing of items between objects. Interactions to be included in an executable model are selected based on an understanding of potential system measures of performance and an understanding of the subject area domain.

The model was designed with two distinct layers: the physical layer at which items such as transporters, troops, equipment, etc., are transacted; and the commu-



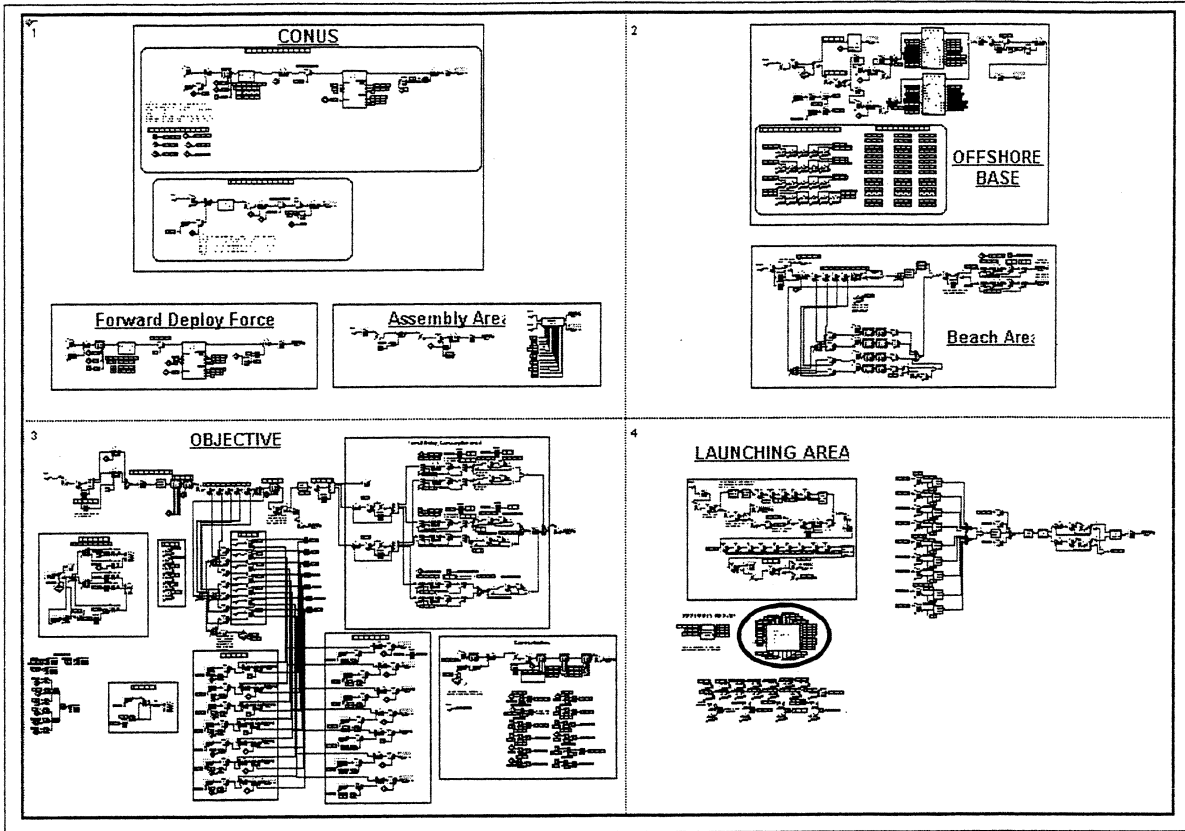

Figure 3. Top-level view of the EXTEND expeditious warfare model for sea basing.

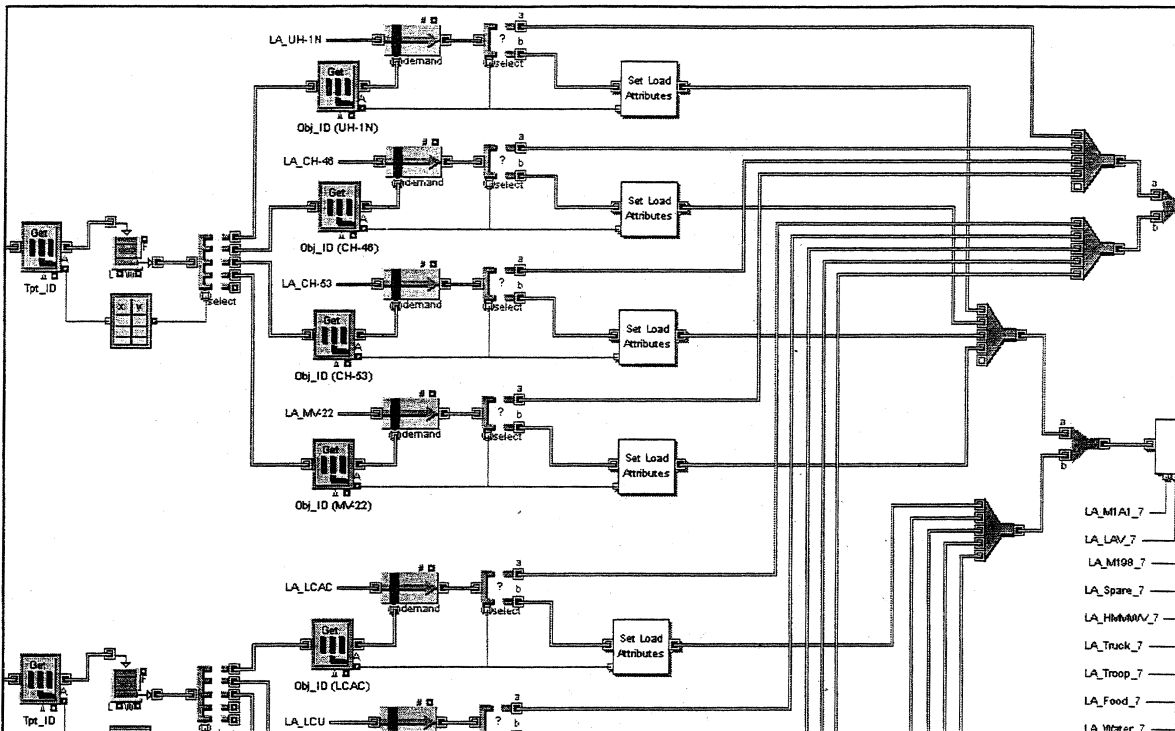

Figure 4. Lower level view within launching area.

nications layer at which messages are exchanged between nodes to coordinate transactions on the physical layer, e.g., logistics demand and fulfillment. The physical layer serves items that flow within and between nodes. The flow of logistic resource items is generally one way, while transporters (carrying mainly the logistic items) flow both ways between the logistic depot and the Objective.

The EXTEND™ model is instrumented to count the arrival of forces, equipment, supplies, and transport vehicles at various system nodes, primarily at the objective, as a function of time. Executable models of general systems-of-systems can be instrumented in a similar manner to track interactions relevant to measures of system performance.

The object-oriented, layered modeling approach has applicability ranging from analysis of military communications architectures [Osmundson et al., 2002] to evaluating software engineering conceptual designs [Purao, Storey, and Han, 2003].

## 5. MODEL INPUT AND EXPERIMENT DESIGN

The loading plan for all the scheduled waves that form the assault force to be launched ashore was an input for the model, making the simulation dependent on the way these scheduled assault waves are planned. Both current and sea-basing models use a constant rate of consumption for the expendable resources. However, the consumption rate of food, water, ammunition, and fuel depends on whether it is a surge or normal consumption scenario. The model accounts for depletion of these resources as a function of the number of troops and the usage of the vehicles at the various locations throughout an operation.

On another note, the model categorizes resources and supplies to ease implementation and interpretation of the output results. Examples of this include representing different types of trucks as a single truck type object, irrespective of their specific capabilities or limitations, and grouping ammunition into broader categories of air, ground, and naval ammunition. However, such characterization still allows realistic emulation of the operation. Generalizing objects as trucks does not eliminate the need to transport them from the ships to shore, placing demands on other transporter assets. Most importantly, this approach enables emulation of ground transportation behavior within an expeditionary warfare system of systems and has the same implications for all three architectures.

A concern in experimenting with the simulation model for this large, complex, interconnected system of

systems is its inherent variability. A given set of design and noise factor parameter values requires sufficient numbers of runs in order to apply statistical methods for comparing measures. The number of iterations quickly grows out of hand. To decrease the number of experiments, analysts employed both classical Design of Experiments [Fisher, 1948; Box, Hunter, and Hunter, 1978] and Taguchi methods [Taguchi and Konishi, 1987].

Design of Experiments and Taguchi methods seek to eliminate sources of variance and establish a basis for comparison of architectures while identifying interactions among design factors. Systems analysts define discrete parameter levels for each design factor, including continuous factors. Modelers select discrete levels of speed for various sea, air, and land transportation vehicles and use the simulation results to indicate the presence or absence of statistically significant differences of high-speed transporters compared to moderate- or low-speed transporters.

A summary of assumptions made in modeling the expeditionary warfare system are as follows:

- All truck types were generalized under a single category, irrespective of their specific capabilities or limitations. Only a certain percentage of the trucks are allocated for transportation purposes, providing for the fact that some of these trucks have other roles.
- Ammunition is grouped into general categories of air, ground, and naval ammunition without further breakout by specific type.
- The number of helicopter spots onboard a ship that are available at any one time is determined by the characteristics of existing ships or the design specifications of conceptual ships. This was a model input, thereby limiting the number of helicopters that may be operating at the same time.
- Carrying capacity and loading plans of transport vehicles are assumed as given for existing vehicles or extrapolated based on design characteristics for conceptual vehicles.
- Weather is modeled as either good or bad. The effect of good weather is that surface craft and aircraft transited at speeds determined by their normal operating characteristics and there was no increment in loading delay and no reduction in surface craft load capacity. The effect of bad weather is to reduce surface craft transit speed by 50%, aircraft transit speed by 30%, surface craft load capacity by 50%, and to increase load times for both surface and air craft by 30%.



## 6. RESULTS

Comparing expeditionary warfare architectures and determining sensitivity of a given architecture to variation in design and noise factors requires a common set of measures of performance. For the assault phase, Combat Power Ashore (CPA) is selected as an index. CPA is an aggregated score to reflect the level of combat power available at any one time at a certain location. The CPA index is a summation of individual Combat Power Index (CPI) scores contributed by entities that compose combat power within the force. The score allocated to the individual entities is based on a RAND study [Allen, 1992]. The most important aspect of this index is that it provides a baseline performance measure for comparison under different conditions within the same operational scenario.

The entities that contribute to combat power used in this analysis are M1A1 tanks, light armored vehicles, assault amphibious vehicles, advanced assault amphibious vehicles, M198 155 mm howitzers, high mobility multipurpose wheeled vehicles, and troops. In expeditionary warfare, there are two phases in building up a force ashore. The first phase is the initial buildup using the expeditionary force's organic assault assets; the second is delivery of the remaining force, either through the arrival of an MPF at the iron mountain for the current architecture or from the sea-based MPF or a conceptual expeditionary warfare ship.

The first analytical objective is to measure, for each architecture, the performance of initial phase assault force projection capability. Hence, the desired force level that is used for this analysis is the force level that is projected based solely on the organic architecture's assault assets before the reinforcement by the logistics ships. The second analytical objective is to find out the performance of the overall force projection capability; for this analysis, the force level includes not only the force built up by the assault assets, but the build up of the remaining force by the logistic ships as well. This allows a more comprehensive analysis of the performance and comparison of the total force built-up capability differences among the three architectures.

Using the CPA scores, two measures of performance (MOPs) are identified to measure the performance of the individual architectures for the assault phase. The two MOPs are the Time to Landing of Advance Force (TAF) at the objective and the Time to Build Up (TBU) a desired level of forces at the objective. TAF is defined as the time taken from the launch of the operation to the establishment of a company level force at the objective; TBU, the time to build to desired force levels, represents the time required to place 80% of an MEB-sized ground combat element and its supporting equipment at the

objective. These MOPs, TAF, and TBU are illustrated in Figure 4, which shows an output of a simulation run for the current architecture. Time, starting with the initial movement of forces and supplies from CONUS, is plotted in days along the horizontal axis. Combat Power Ashore, or CPA, is plotted on the vertical axis in terms of dimension-less units based on the number and type of force elements ashore and their corresponding CPI as determined by the RAND study. TAF and TBU are shown in Figure 5 as the times required to build up to the advance force level at the objective and to build up to the desired force level at the objective, respectively. Short-term oscillations and long term decrease in force level are caused by attrition of the forces coupled with the capacity and latency of the force delivery system with no replacement for armor vehicles lost during combat.

The measures TAF and TBU resulting from the simulation runs for the three architectures are analyzed as functions of design factors and noise factors and plotted on interaction plots, an example of which is shown in Figure 6, displaying TBU for the conceptual architecture with respect to local weather and proximity of the sea base to the objective. The upper left hand quadrant of the plot shows that proximity goes from "close" at the bottom to "far" at the top. The quadrant at the bottom right indicates that weather goes from "good" at the left to "poor" to the right. Specific values for "close" and "far" as well as specific values of speed of transport and loading and unloading corresponding to good and bad weather are inputs to the models. The upper line in the topmost quadrant on the right shows the added delay in building up a force at the objective in days when proximity is "far" and weather varies between good and poor. The bottom line in the same upper right hand quadrant shows the effect of weather when proximity is "close."

Results show that the effect of weather has a stronger influence on the architecture at farther distances from the objective. This is reasonable and demonstrates that susceptibility to weather conditions is a critical factor for operations at distances over-the-horizon. Despite degradations in both air and surface transshipment of material, the greater speed of air transport over boat movement makes this method more robust against deteriorating weather than use of surface vessels.

Looking more deeply at sources of variability in projecting and operating forces ashore, high attrition rates and a significant mine threat on the landing beaches do slow the time taken to build up the desired force, but the difference is only marginal compared to the effects resulting from varying the proximity and the impact of changing weather. Attrition reduces the number of transporters, but this can be overcome by the use

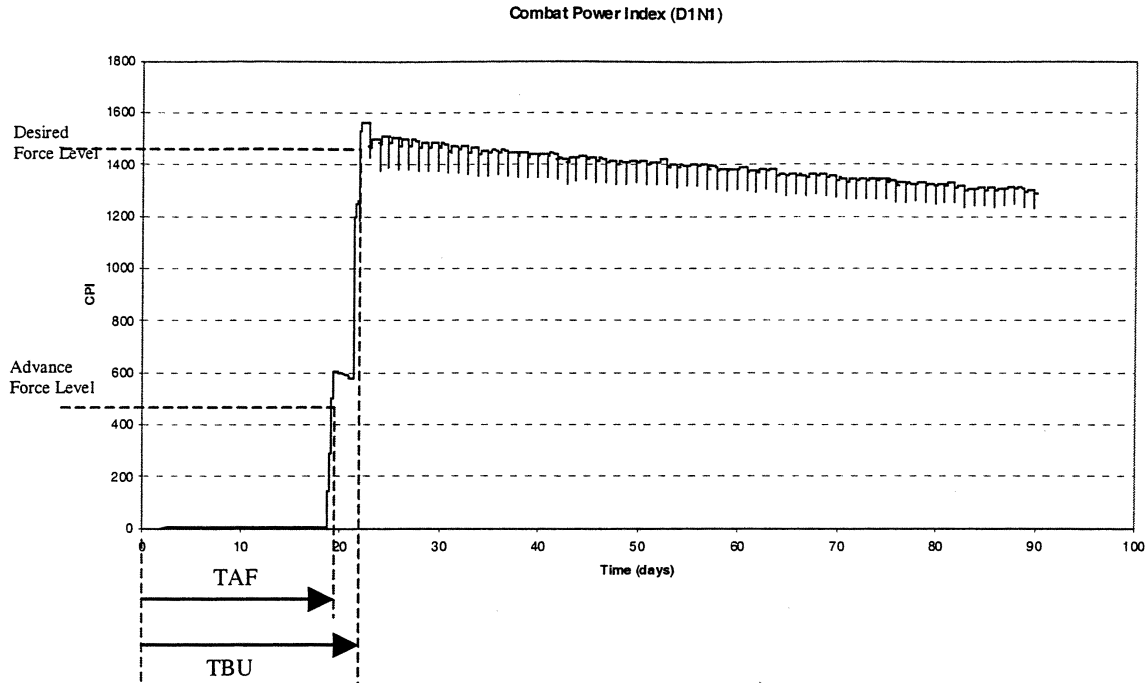

Figure 5. Depiction of Time to Advance Force (TAF) and Time to Build Up at objective (TBU).

of transporters held in reserve. Mine threat reduces the number of available landing lanes, but this can be greatly overcome by heavier utilization of the available landing lanes. The same simulation runs made for the planned and conceptual expeditionary warfare architectures show significant improvement in the robustness of those architectures across all noise factors. The time to initial landing of the advance force at the objective is shown in Figure 7.

The conceptual architecture is able to project the first company of Marines ashore fastest, while the planned and current architectures take longer and are approxi-

mately equal in their performance. This is due to higher transit speeds built into conceptual amphibious ships, enabling them to get on station in a much shorter time.

The time taken to project a force with a combat power index equivalent to an 80% MEB level at the objective is shown in Figure 8. Again, the conceptual architecture is the one that will project 80% of the MEB ashore in the shortest amount of time. The conceptual architecture is able to achieve the shortest time because the newly designed expeditionary warfare ships are able to get on station the fastest, and their increased load out of aircraft and surface crafts coupled with increased lift capability allows the MEB to project the force ashore with fewer trips.

The analysis is also concerned with the process of sustaining the force sent ashore, comparing the number of days of supply held at the iron mountain (for the current architecture) and at the objective throughout the 90-day duration of the mission.

For the logistics sustainment phase, the analysts use aggregated Mean Squared Error (MSE) of each class of daily sustainment categories required to sustain an operation ashore as the MOE [Frey, 2000]. The three classes of daily requirements are food and water, fuel, and ammunition, measured at the iron mountain, sea base, and the objective. MSE accounts for bias and variability of sustainment levels for the three resources as they deviate from desired levels. The aggregated

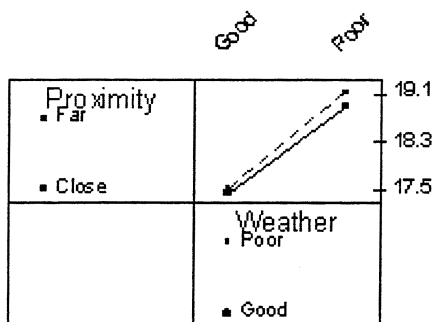

Figure 6. Interaction Plot - Data Means for Time to Build up Force (Days). TBU interactions between proximity and weather factors for conceptual architecture.

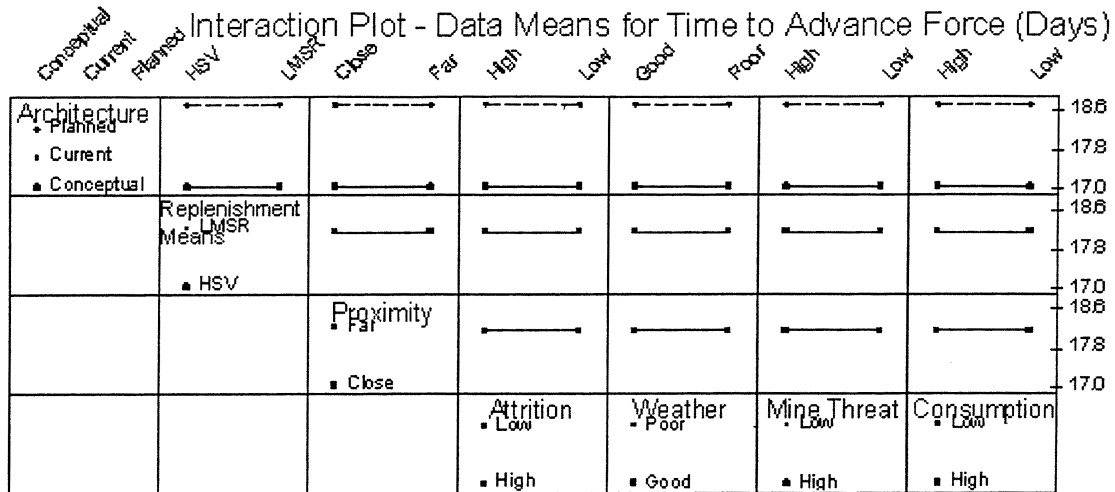

Figure 7. Sample means for TAF for the three architectures.

MSE is obtained through averaging the MSEs of the three resource levels.

Figure 9 shows sustainment level in terms of days of supply (DOS) of fuel, food, water, and ammunition on the vertical axis versus time required to build up the supply levels. Oscillation in the supply levels is caused by consumption of supplies coupled with the time delay to rebuild the supply level. In the EXTEND™ model, resupply of the objective is demand driven by the level of supply at the objective and the consumption rate of food, fuel and ammunition by the forces ashore. Figure 10 summarizes the dependence of MSE on design and noise factors.

Although simulation results show that the current architecture sustains the highest levels among the three architectures in sustaining the force at the objective, sea basing is a feasible option for supporting operating forces ashore, given good weather. The iron mountain has a huge capacity to transport resources over land to the objective, which is not significantly diminished by poor weather or attrition due to enemy action. As a result, the objective is able to hold at least 4 days of supply independent of any other factor effects. The planned architecture using a sea base is also able to sustain the force at the objective just as well as the iron mountain in the current architecture when the MEB is

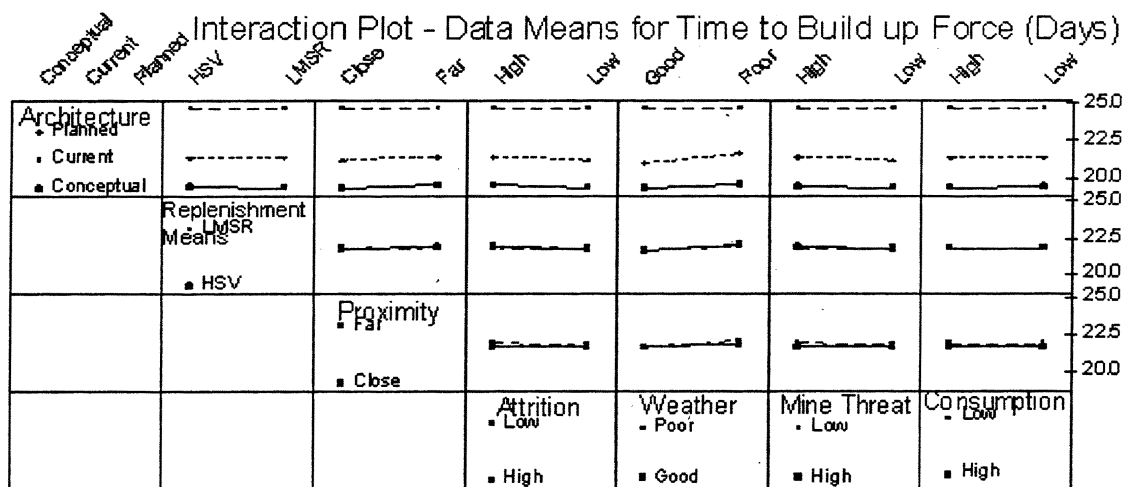

Figure 8. Data means for TBU for three architectures.

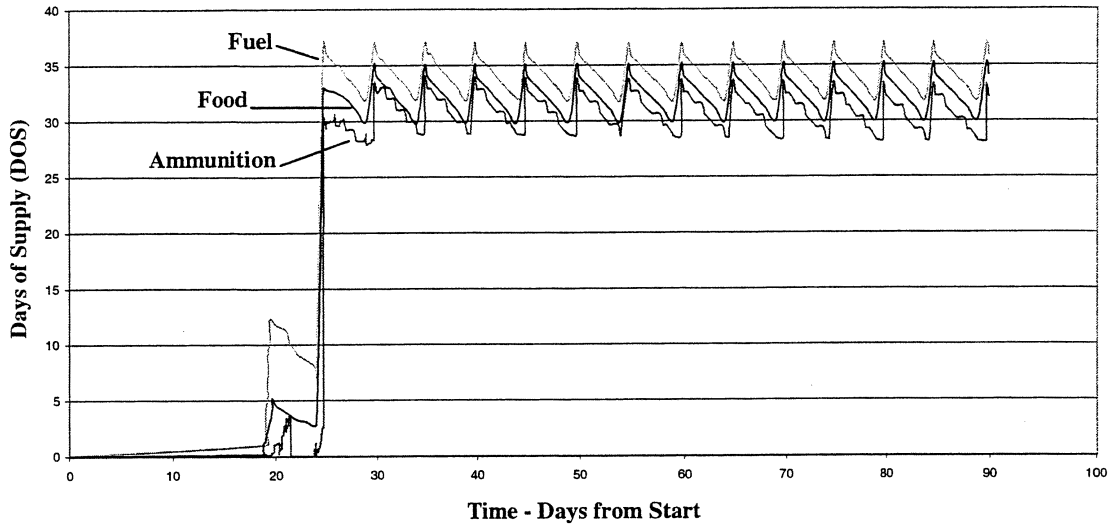

Figure 9. Sustainment levels at the objective for the current architecture.

operating in good weather conditions. Once weather conditions deteriorate, the sea base has reduced capacity to move resources to the objective and levels decrease to an average of 3 days of supply. The planned architecture can sustain the objective just as well as the current architecture if transporters that are more robust against the effects of weather through better sea keeping and transloading capabilities are constructed.

Analyzing the ability of a sea base to support operations at a distant objective experiments covered operations traversing four different distances— 58, 108, 158, and 208 nm—from the sea base to the objective. Increasing the distances between the sea base and the

objective results in an increase in the TBU as shown in Table IV. This difference in buildup time is intuitive, but it shows that it is possible to build up the forces ashore to the required level. Concern regards whether the forces ashore can be sustained from the different distances. The variability in the level of supplies at the logistics depot as a function of varying distances from the sea base to the objective is an output of simulations. For example, Figure 11 depicts performance of the planned architecture at a distance of 158 nm from the sea base to the objective.

Analysts obtain MSE of days of supply (DOS) on hand as a function of distance to the objective and the

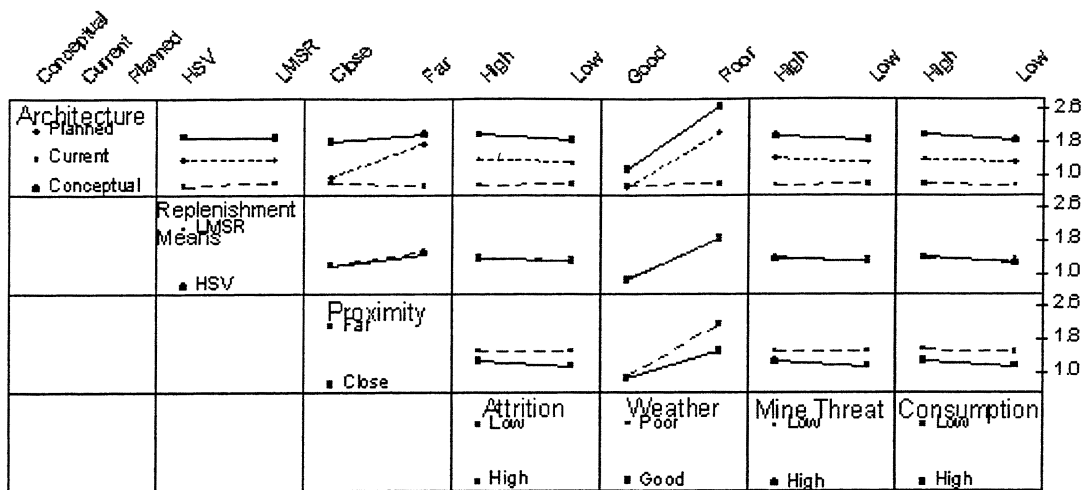

Figure 10. Data means for MSE of supplies at the objective for three architectures.

**Table IV. Time to Build Up at Objective (TBU) for Sea-based Forces—Effect of Distance to the Objective**

TBU (days)	Distance of Sea Base from Objective			
	58 nm	108 nm	158 nm	208 nm
	20.9	21.1	21.25	21.4

maximum time that the objective could be supported before one or more of the replenishment items—food, water, fuel, and ammunition—fall below a sustainment level. As expected, MSE at the objective increases as sea base distance from the objective increases. The sea base is able to sustain the duration of the operation at distances of 58 nm and 108 nm, but is unable to sustain it from 158 nm for more than 30 days, or 20 days at a 208 nm distance. The sea base proves unable to support fuel levels. The system is unable keep up with increased consumption as more re-supply missions are flown or launched.

Replenishment studies identified potential areas for future system improvement. In order to have a functioning sea base that can sustain the forces ashore indefinitely at over-the-horizon distances, the replenishment system needs to be more robust or the load on the system reduced to allow it to function effectively at longer distances. This can be accomplished by reducing the consumption of resources at the objective through more efficient usage of fuel and ammunition. More fuel efficient hardware systems that consume less fuel and using stand-off precision strike weaponry will decrease consumption at the objective and will enable the sea base to support forces at greater distances. Shifting to sea-

based and air-based responsive precision strike weaponry will relieve the MEB from having to move armor and artillery ashore, thus significantly decreasing fuel requirements at the objective.

Experiments looked at four different options using varying proportions of air and sea assets for replenishing the objective from the sea base. This boiled down to a trade between speed and survivability. Replenishing entirely by air assets resulted in the lowest MSE of days of supply, and, conversely, replenishing entirely by sea assets resulted in the highest MSE. The 100% air replenishment option was subject to high levels of attrition due to the tremendous number of sorties required to replace a single landing craft load, however. This increased aircraft exposure to enemy fire. One hundred percent air replenishment is only viable in a low or no attrition environment, which translates to air superiority and dominance of the theater’s air space. Finally, some combat equipment cannot be airlifted, such as the M1A1 tank. Even when a 100% air replenishment option is used, the M1A1 would still be a surface-delivered combat system. Resources like food, fuel, and ammunition may be air or sea delivered depending on the option chosen.

The high level results of this process modeling analysis give the first quantitative evidence that sea-basing is a viable expeditionary warfare concept. Results also show the performance of the three expeditionary warfare system architectures and the sensitivity of performance to various design and noise factors and provide guidance for future studies of expeditionary warfare systems.

Process modeling of other systems-of-systems can be expected to yield similar outcomes: The identification of driving system design factors, expected perform-

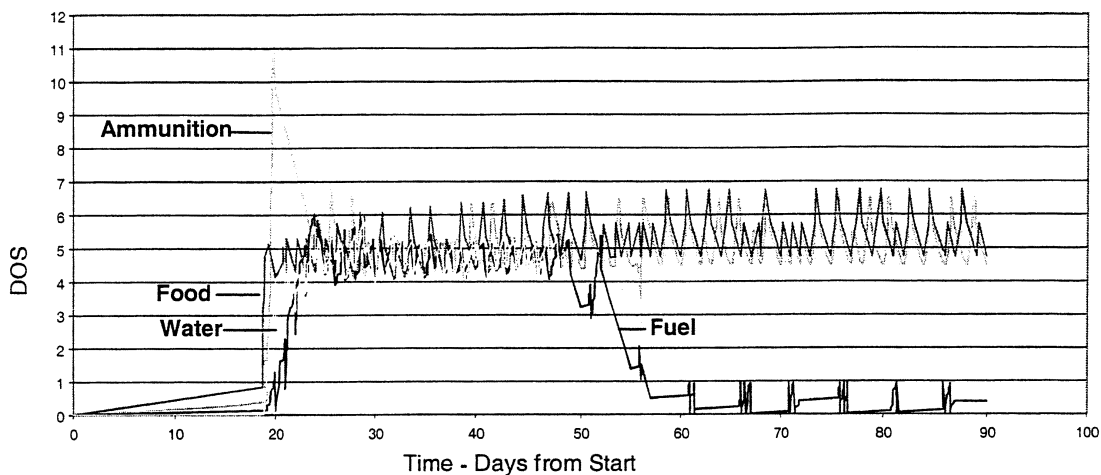

**Figure 11.** Sustainment levels (days of supplies) over 150-plus miles from sea base to objective.



ance levels at a level of detail consistent with the level of system abstraction, and the sensitivity of performance levels to noise factors. Thus, process modeling is valuable for identifying the most promising system trade space and guiding the development of system concepts.

## 7. CONCLUSIONS

Architectural analysis of complex systems-of-systems using process modeling is illustrated by the example of future expeditionary warfare systems. The models developed in this effort capture the objects, methods, and relationships expected throughout this complex, dynamic operating system. The process modeling method enables the analysis of the dependence of architecture performance on system design factors and operational noise factors.

Process modeling can be used in a similar way as a systems engineering tool to identify and analyze the most important design parameters in any complex systems-of-systems whose performance depends strongly on process timelines.

The approach to general systems-of-systems architectural analysis problems is identical to that discussed for the expeditionary warfare example. Starting at high level, the design parameters that are expected to have significant impact on system performance must be identified. The potential architectures that result from variations in the design parameters are modeled in a manner similar to UML swim-lane diagrams shown in Figure 1. The system-of-systems of interest is treated as a collection of objects that interact by passing physical and logical items to one another. The explicit time behavior of the system-of-systems is captured by converting the swim-lane view of the system into an executable object-oriented model that is instrumented to capture performance parameters of interest. The object-oriented nature of the executable models reduces the modeling effort when building models of different architectures; changes to an architecture can be localized to changes in specific objects and changes in specific object interactions. Some architectures will be represented by distinctly separate models, and some will be represented by parameter variations within the same model. The choice of parameter values must be informed by a detailed study of the problem domain. External factors that may affect system behavior, called noise factors in this paper, must also be identified, and a reasonable range of noise factor parameter values must be determined. Design of experiments can be used to reduce the number of models and simulation runs to a manageable number, and analysis of results in con-

junction with design of experiments allows the extraction of system performance dependencies on the design factors and system performance sensitivities to noise factor variations.

The level of abstraction of executable models is determined by the level of analysis required. Typically, as is the case of the expeditionary warfare model, initial analyses are done at a high level of abstraction and the questions to be answered concern first order feasibility and identification of the best trade space for further analyses.

The Wayne E. Meyer Institute of Systems Engineering at the Naval Postgraduate School is applying the process modeling method to studies of complex information and decision system-of-systems. The executable models encompass all of the elements in these systems—the communication systems, processing systems, and people. We analyze variations in communication methods including electronic data transmission by various means, voice and couriering, variations in communication system parameters, reliability of communication channels and processing systems, message loading on the communication system and work loading on people, and changes in business rules as they affect system performance. Results will be used to identify near-term and long-term approaches to system improvement.

## REFERENCES

- P. Allen, Situational force scoring: Accounting for combined arms effects in aggregated combat models, RAND® Strategy Assessment Center, Santa Monica, CA, 1992.
- D.P. Bertsekas and R. Gallager, Data networks, 2nd edition, Prentice-Hall, Englewood Cliffs, NJ, 1991.
- G.S. Box, W.G. Hunter, and J.S. Hunter, Statistics for experimenters, Wiley, New York, 1978.
- Adm. V. Clark, Chief of Naval Operations, Sea power 21: Operational concepts for a new era, spoken remarks to the Current Strategy Forum, Naval War College, Newport, RI, June 12, 2002.
- Deputy Chief of Naval Operations (unknown), Naval vision 2020: The future... from the sea, Department of the Navy, Washington, DC, 2000.
- CNO (N75), Director, Maj. Gen. W.A. Whitlow, Expeditionary Warfare Division, N75, Naval expeditionary warfare: Decisive power, global reach, Department of the Navy, Office of the Chief of Naval Operations, Washington, DC, July 31, 2002.
- G.R. England, Naval transformational roadmap: Power and access... from the sea, Department of the Navy, Washington, DC, 2002.
- R.A. Fisher, Statistical methods for research workers, Oliver and Boyd, Edinburgh, 1948.

- C.M. Frey, An evaluation of sea-based sustainment of forces, Masters of Science in Operations Research Thesis, Naval Postgraduate School, Monterey, CA, September 2000.
- C. Larman, Applying UML and patterns, Prentice-Hall, Upper Saddle River, NJ, 1998.
- Marine Corps Combat Development Command, Ship-to-objective maneuver, MCCDC, Quantico, VA, July 25, 1997.
- V. Adm. D.V. McGinn, Memorandum for Director, Institute for Defense Systems Engineering and Analysis (IDSEA), OPNAV N7, Ser N7/U655632, Department of the Navy, Navy Postgraduate School, Washington, DC, April 12, 2002.
- J.S. Osmundson, A systems engineering methodology for information systems, *Syst Eng* 3(2), 68–81.
- J.S. Osmundson, L.T. Arp, M.A. Parker, K.J. Stewart, and W.G. Kemple, Scaling analysis of wireless local area network technology to large scale battlefields, *Mil Oper Res* 7(1) (2002), 57–68.
- S. Purao, V.C. Storey, and T. Han, Improving analysis pattern reuse in conceptual design: Augmenting automated processes with supervised learning, *Inform Syst Res* 14(3) (2003), 269–290.
- SEIa (Systems Engineering Integration), Final Report, 2003, <http://www.nps.navy.mil/sea/exwar>.
- SEIb (Systems Engineering Integration), Final Report, Chap. XIV, Long range, heavy lift aircraft, 2003, <http://www.nps.navy.mil/sea/exwar>.
- SEIc (Systems Engineering Integration), Final Report, Chap. XV, TSSE (Total Ship Systems Engineering) expeditionary warfare design, 2003, <http://www.nps.navy.mil/sea/exwar>.
- G. Taguchi and S. Konishi, Taguchi methods, orthogonal arrays and linear graphs, ASI (American Supplier Institute) Press, Dearborn, MI, 1987.
- USMC, Headquarters, U.S. Marine Corps, Operational maneuver from the sea, Department of the Navy, Washington, DC, January 4, 1996.
- USMC, Headquarters, U.S. Marine Corps, Organization of Marine Corps Forces MCRP 5-12D, MCCDC, Quantico, VA, October 13, 1998a.
- USMC, Headquarters, U.S. Marine Corps, Expeditionary maneuver warfare, Department of the Navy, Washington, DC, April 16, 1998b.
- USMC, Headquarters, U.S. Marine Corps, Marine Corps Strategy 21, Department of the Navy, USMC, Washington, DC, 2000.
- USMC, Headquarters, U.S. Marine Corps, Expeditionary maneuver warfare, Department of the Navy, USMC, Washington, DC, November 2001a.
- USMC, Headquarters, U.S. Marine Corps, MAGTF planner's reference manual MSTP, Pamphlet 5-0.3, MCCDC, Quantico, VA, April 2001b.



John Osmundson is a Research Associate Professor with joint appointments in the systems engineering and information science departments at the Naval Postgraduate School in Monterey, CA. His research interest is applying systems engineering and computer modeling and simulation methodologies to the development of system architectures, performance models, and system trades of time-critical information systems. Prior to joining the Naval Postgraduate School Dr. Osmundson worked for 23 years at Lockheed Missiles and Space Company in Sunnyvale and Palo Alto, CA as a systems engineer, systems engineering manager, and manager of advanced studies. He received a B.S. in physics from Stanford University and a Ph.D. in physics from the University of Maryland. Dr. Osmundson is a member of IEEE and is a charter member of the San Francisco Bay Area chapter of INCOSE.



Russell Gottfried is a Surface Warfare Officer, currently serving as a military faculty member of the Operations Research Department at the Naval Postgraduate School, where he earned an MSOR in 1992. A career fleet operator, his research and teaching efforts focus on the application of analytical decision-making processes to operational issues.



Chee, Yang Kum is a Major in the Republic of Singapore Navy and is currently a Branch Head in the Joint Plans Department, Singapore Ministry of Defence. He graduated with a masters degree in systems analysis from the Naval Postgraduate School in December 2002 and has a BEng (Hons) from the University of Surrey, UK.



Lau, Hui Boon is a Captain in the Singapore Armed Forces assigned to Headquarters Singapore Guards. He graduated with a masters degree in systems analysis from the Naval Postgraduate School in December 2002. After he was commissioned in 1994, Captain Lau was accepted into the National University of Singapore, where he received a BEng (Hons) in 1998.



Lim, Wei Lian is a Major in the Singapore Armed Forces assigned to Headquarters Singapore Artillery. He earned a masters degree in systems analysis from the Naval Postgraduate School in December 2002. After he was commissioned into the Singapore Armed Forces, Major Lim was accepted into the U.S. Military Academy, where he received a B.S. degree.



Poh, Seng Wee Patrick is a Major in the Republic of Singapore Navy and graduated with a masters degree in systems engineering and integration from the Naval Postgraduate School in December 2002. Shortly after attaining his commission from the Midshipment School in Singapore in 1990, Major Poh was sponsored to study in University of Manchester Institute for Science and Technology (UMIST) UK, where he graduated with a B. Eng (Hons) degree in 1994. Major Poh's follow on tour is in Naval Plans Department at Headquarters Republic of Singapore Navy.



Tan, Choo Thye is a Captain in the Singapore Armed Forces (Armour), graduated with a masters degree in systems analysis from Naval Postgraduate School in December 2002 and masters degree in industrial & systems engineering from National University of Singapore in June 2002. After graduating from Officer Cadet School in Singapore, Captain Tan was awarded the Academic Training Award where he received a B.A. degree from National University of Singapore. Captain Tan's follow-on tour is as a Weapon Staff Officer at the headquarters of Armour Formation, Singapore.