



## Calhoun: The NPS Institutional Archive

---

Faculty and Researcher Publications

Faculty and Researcher Publications

---

1992

# From virtual world to reality: designing an autonomous underwater robot

Bruntzman, Donald P.

---

Presented at the AAAI Fall Symposium on Applications of Artificial Intelligence to Real-World Autonomous Mobile Robots, Cambridge, Massachusetts, October 23-25, 1992, pp. 18-22.



Calhoun is a project of the Dudley Knox Library at NPS, furthering the precepts and goals of open government and government transparency. All information contained herein has been approved for release by the NPS Public Affairs Officer.

**Dudley Knox Library / Naval Postgraduate School**  
**411 Dyer Road / 1 University Circle**  
**Monterey, California USA 93943**

<http://www.nps.edu/library>

# From virtual world to reality: designing an autonomous underwater robot

Donald P. Brutzman  
Computer Science Department, Naval Postgraduate School  
Monterey California 93943-5000 USA  
brutzman@cs.nps.navy.mil  
(408) 656-2149 work, (408) 656-2595 fax

## Abstract

Design of autonomous underwater robots is particularly difficult due to the physical and sensor challenges of the underwater environment. Inaccessibility during operation and low probability of failure recovery makes robot stability and reliability paramount. Building an accurate and complete virtual world simulation is proposed as a necessary prerequisite for design of an autonomous underwater robot. A virtual world can include actual robot components and models for all other aspects of the world. Robot design can be fully tested using a virtual world and then verified using the real world. Additional testing can be performed in the virtual world that is not feasible in the real world. Visualization of robot interactions within a virtual world permits sophisticated analysis of robot performance that is otherwise unavailable. All aspects of world modeling and robot design must be mastered and coordinated in order to build an authentic virtual world and capable autonomous robot.

## 1 Problems

Autonomous underwater robot design is difficult. Unlike most other mobile robots, underwater robots must operate unattended and uncontrolled in a remote and unforgiving environment. Inaccessibility during operation greatly complicates the design and evaluation of system software. In order to ensure complete reliability, however, robot software and hardware need to be fully tested in a controlled environment before operational deployment. Such comprehensive testing requirements cannot be met using a standalone laboratory robot due to the complexity and unpredictability of interactions that can occur in the actual remote environment. A different approach is needed which can effectively support research on the many problems facing underwater robot designers.

Underwater robots are normally termed autonomous underwater vehicles (AUVs), not because they are intended to carry people but rather because they are designed to intelligently convey sensors and payloads. AUVs must accomplish complex tasks and

diverse missions while maintaining stable physical control with six spatial degrees of freedom. Little or no communication with distant human supervisors is possible. When compared to indoor, ground, airborne or space environments, the underwater domain typically imposes the most restrictive physical control and sensor limitations upon a robot. Underwater robot design requirements therefore motivate this examination. Considerations and conclusions remain pertinent as worst-case examples in other environments.

A large gap exists between the projections of theory and the actual practice of underwater robot design. Despite a large number of remotely operated submersibles and a rich field of autonomous robot research results (Iyengar and Elfes 1990a, 1990b), few AUVs exist and their capabilities are limited. Cost, inaccessibility and scope of AUV design restrict the number and reach of players involved. Interactions and interdependencies between hardware and software component problems are poorly understood. Testing is difficult, tedious, infrequent and potentially hazardous. Meaningful evaluation of results is hampered by overall problem complexity, sensor inadequacies and human inability to directly observe the robot *in situ*. Potential loss of an autonomous underwater robot is generally intolerable due to tremendous investment in time and resources, likelihood that any failure will become catastrophic and difficulty of recovery.

Underwater robot progress has been slow and painstaking for many reasons. By necessity most research is performed piecemeal and incrementally. For example, a narrow problem might be identified as suitable for solution by a particular artificial intelligence (AI) paradigm and examined in great detail. Conjectures and theories are used to create an implementation which is tested by building a model or simulation specifically suited to the problem in question. Test success or failure is used to interpret validity of conclusions. Unfortunately, integration of the design process or even final results into a working robot is often difficult or impossible. Lack of integrated testing prevents complete verification of conclusions.

AUV design must provide autonomy, stability and reliability with little tolerance for error. Control systems require particular attention since closed-form

solutions for many hydrodynamics control issues are unknown. In addition, AI methodologies are essential for many critical robot software components, but the interaction complexity and emergent behavior of multiple interacting AI processes is poorly understood, rarely tested and impossible to formally specify. Better approaches are needed to support coordinated research, design and implementation of underwater robots.

Despite these many handicaps, the numerous challenges of operating in the underwater environment force designers to build robots that are truly robust, autonomous, mobile and stable. This fits well with a motivating philosophy of Hans Moravec: "... solving the day to day problems of developing a mobile organism steers one in the direction of general intelligence... Mobile robotics may or may not be the fastest way to arrive at general human competence in machines, but I believe it is one of the surest roads." (Moravec 1983)

## 2 Multiple Interacting Processes

Designing an AUV is complex. Many capabilities are required for an underwater mobile robot to act capably and independently. Stable physical control, motion control, sensing, motion planning, mission planning, replanning and failure recovery are example software components that must be solved individually for tractability. The diversity and dissimilarity of these many component subproblems precludes use of a single monolithic AI paradigm.

Distributed AI usually addresses specifications and protocols between similar autonomous agents working cooperatively on global problems. Hybrid reasoning often refers to novel combinations of two or three techniques to improve overall performance when solving a single problem type. Neither definition appears suitable for general robot control. Multiple dissimilar AI processes must interact in an intelligent manner to achieve the robust capabilities and multiple behaviors needed by a mobile robot (Elfes 1986). A variety of robot architectures have been proposed and developed to provide the control framework under which multiple AI processes can interact. A brief discussion of current robot architectures is therefore useful to clarify the scope of robot design issues.

Robot architectures can be classified over a spectrum that ranges from hierarchical to reactive (Byrnes et al. 1992). Hierarchical architectures are deliberative, symbolic, structured, "top down," goal-driven, have explicit focus of attention and are often implemented using backward inferencing. Hierarchical approaches typically contain world models and use planning and search techniques to achieve strictly defined goals. Hierarchical architectures tend to be somewhat rigid, unresponsive in unpredicted situations and computation-intensive, yet remain capable of highly sophisticated performance.

Reactive architectures are subsumptive, "bottom up," sensor-driven, layered and may often be characterized by forward inferencing. Reactive architectures attempt to combine robust subsuming behaviors while avoiding dynamic planning and world models. Reactive architectures appear to behave somewhat randomly and achieve success without massive computations by using well-considered behaviors that tend to lead to task completion (Brooks 1986). Scaling up to complex missions is difficult. Stability and deterministic performance is elusive.

It is interesting to note that numerous robot architecture researchers have recently proposed hybrid control architectures (Kwak et al. 1992) (Bonasso et al. 1992) (Bellingham and Consi 1990) (Payton and Bihari 1991) (Spector and Hendler 1991). A common theme in these proposals is integrating the long-term deliberation, planning and state information found in hierarchical approaches with the quick reaction and adaptability of subsumptive behaviors. Individual weaknesses of hierarchical and reactive architectures appear to be well-balanced by their respective strengths.

Stability and reliability deserve repeated mention in the context of multiple interacting processes. Control system considerations are often overlooked under the guise of simplifying assumptions that hide important real world restrictions and pitfalls. Robot survivability dictates that physical and logical behavior must always converge to a stable yet adaptive set of states. Divergence, deadlock, infinite loops and non-linear dynamic behavior must be detectable and controllable. Real-time operating constraints on sensing, processing, action and reaction must be similarly resolved. Stability prerequisites become similarly important for ground robots as they progress from structured to unrestricted environments.

## 3 Virtual World

The broad requirements of underwater robot design provide a strong argument against piecemeal design verification. Individual component simulations are not adequate to develop effective AI-based systems or evaluate overall robot performance.

Virtual world systems provide the capability to see and interact with distant, expensive, hazardous or non-existent three-dimensional environments (Zyda and Pratt 1992). A virtual world is intended to provide complete functionality of the target environment in the laboratory. A virtual world can provide adequate simulation scope and interaction capability to overcome the inherent design handicaps imposed when building a remote robot to operate in a hazardous environment. Construction of a virtual world for robot development and evaluation is hereby proposed as a necessary prerequisite for successful design of a complex remote robot such as an AUV.

A virtual world which is used to recreate every aspect of the environment external to the robot must also include robot sensors and analog devices (such as thrusters and rudders) which are impossible to realistically operate in a laboratory. Interactions between software processes, vehicle hardware and the real world must all be comprehensively modeled and mutually consistent. Robot physical behavior and sensor interactions must be adequately simulated. The robot itself is directly plugged into the virtual world using normal sensor and actuator connections. The difference between operation in a virtual world or an actual environment must be transparent to the robot in order to be effective. Successful implementation of the virtual world can be validated by identical robot performance in each domain.

The potential value of general world simulators has been previously recognized (Moravec 1988). Certain underwater robots already benefit from the availability of capable simulators (Pappas et al. 1991) (Brutzman 1992a) (Brutzman et al. 1992b). However, once simulation sophistication reaches that of a virtual world, interesting things become possible. Emergent behavior from interaction between multiple AI processes and the environment becomes evident. Sensor interactions can be repeated indefinitely in order to develop new analysis algorithms and achieve fine-tuned sensor performance. Machine learning based on massive repetitive training becomes feasible and can be conveniently monitored. Potentially fatal scenarios can be attempted without risk to robot, human or environment.

A plethora of interrelated requirements requires mastering all aspects of world modeling and robot design in order to build both an authentic virtual world and a capable autonomous robot. Traditionally only component software processes were integrated into the robot architecture; now corresponding validation simulations must also be integrated into the virtual world. Adequate simulation of a comprehensive underwater virtual world is possible since precise models are available for kinematics (Badler et al. 1991) (Zyda et al. 1991) (Zyda et al. 1990), hydrodynamics (Yuh 1990) (Abkowitz 1969), sonar response (Etter 1991), and other objects in the underwater environment (Pentland 1990). Characteristics of the underwater vehicle physical components which require modeling can be handled on a case basis (Pappas 1991). Depending upon planned missions and AUV hull form, interactive terrain modeling (Pratt et al. 1992) and precise hydrodynamics modeling are areas likely to require further investigation prior to implementation. Virtual world construction requires significant coordination and cross-disciplinary efforts.

From a design viewpoint, models replace functionality otherwise found only in the real world. Identical replication of every world characteristic is

impossible but partial modeling of all pertinent world aspects is necessary. Exact reproduction of real world behavior might even be undesirable in some cases. For example, a sonar model might provide perfect range and intensity values that can be augmented by statistically adjustable noise and errors. Initial training or evaluation of a new sensor algorithm is best performed using the "perfect" error-free model. Further analysis using quantifiable noise and errors will provide new insight into algorithm robustness and adaptability. Because it has been coupled with the robot's ability to move freely throughout a virtual world, overall effectiveness of this example AI-based sensor process is likely to be superior to that obtainable by training in the real world.

Models in virtual worlds can be further studied to examine the benefits of controllable error precision, addition of uncertainty, incorporation and extension of actual sensor data, and maintaining internal world consistency throughout mutual interactions between individual component models and the multifaceted autonomous robot. Such study also clarifies understanding of robot design problems and specifications.

## 4 Visualization

A robot interacting within a virtual world permits complete visualization of all aspects of both robot and virtual environment. Visualization of robot performance is essential for evaluating both the precise details of low-level execution and the broad suitability of high-level behaviors. Visualization of robot interactions permits sophisticated analysis that is not possible using traditional test methods such as individual software module evaluation, direct robot observation or post-mission reconstruction.

Human beings are visually oriented. Being able to see and control location and time in a moving picture allows us to quickly and intuitively understand data sets of much higher dimensionality than is otherwise possible. Scientific visualization of a robot in its surroundings can greatly improve our comprehension of what is really going on. Being able to "look" over a robot's shoulder or "see" through a robot's sensors provides completely new perspectives. Addition of aural cues provides a further order-of-magnitude increase in perceptual bandwidth. Visualization techniques greatly improve the effectiveness of complex AI process design and development, and can even enable successful AI-based applications that might otherwise be infeasible (Brutzman et al. 1992c).

## 5 Implementation

Constructing a virtual world and designing an autonomous underwater robot are big jobs. This section outlines some design considerations for implementing them in combination.

You've got to get your arms around the world! A robot development team has to understand the fundamental basis of every virtual world component and every robot component. All efforts must be considered in relation to the virtual world models and overall robot architecture. Most research results are partial and developed in isolation, which may be why current autonomous robots rarely achieve a level of performance that can be considered intelligent. The many details of world modeling and robot design must be addressed in a comprehensive, coordinated manner or the overall problem remains unbounded.

A virtual world ought to include interfaces for the actual robot or have duplicate robot processing hardware directly connected. As mentioned previously, which environment is active should not be evident to the robot. If robot behavior is affected by substitution of a virtual world for the actual world then laboratory results become suspect. Reverification of laboratory results in the real world due to inadequacies in the virtual world will be time-consuming, ambiguous and possibly contradictory. Identical robot performance in each domain allows development of a single version of robot software, a valuable software engineering consideration.

Virtual world simulation and visualization graphics rendering are computationally expensive. A distributed implementation can solve real-time processing bottlenecks by exploiting the implicit parallelism that is available over networked workstations. A distributed approach also permits rapid access to multiple versions of robot control software and addition of an indefinite number of virtual robots into the virtual world. A side benefit of a networked implementation is accessibility for remote research. The theoretical basis and construction of virtual worlds remains an area of active investigation (Rheingold 1991).

Theory will continue to outstrip the practice of autonomous underwater robotics unless improved design methodologies are employed. Overall problem complexity and the importance of emergent behavior dictate that actual robot implementations need to be used to confirm broad theoretical conclusions.

Many of the conclusions reached in this paper are based on work accomplished with the Naval Postgraduate School AUV (Healey et al. 1992) (Brutzman and Compton 1991). Using an actual robot with measurable performance greatly clarifies research conclusions. Building a virtual world that matches the environment used by an actual robot is expected to accelerate robotic research progress and provide credible, verifiable results.

## 6 Conclusions

Use of a virtual world can greatly improve development of multiple interacting AI-based processes that are the critical components of autonomous underwater robots. Construction of an underwater virtual world is feasible. Scientific visualization of robot interactions in a virtual world can improve our perceptual capabilities by several orders of magnitude, enabling more effective research progress. Every aspect of virtual world and autonomous robot design must be considered and implemented in a coordinated manner.

## Acknowledgments

I thank Michael J. Zyda, Yutaka Kanayama, Robert B. McGhee, Anthony J. Healey and David R. Pratt for their contributions.

## References

- Abkowitz, M.A. 1969. *Stability and Motion of Ocean Vehicles*, MIT Press, Cambridge, Massachusetts.
- Badler, Norman I., Barsky, Brian A. and Zeltner, David, ed. 1991. *Making Them Move: Mechanics, Control and Animation of Articulated Figures*, Morgan Kaufmann Publishers Inc., San Mateo, California.
- Bellingham, J.G. and Consi, T.R. 1990. "State Configured Layered Control," *Proceedings of the First IARP Workshop on Mobile Robots for Subsea Environments*, Monterey, California, October 23-26, 1990, pp. 75-80.
- Bonasso, R. Peter, Yoerger, Dana R. and Stewart, W. Kenneth. 1992. "Semi-Autonomous Underwater Vehicles for Shallow Water Mine Clearing," IEEE Oceanic Engineering Society Symposium on Autonomous Underwater Vehicles, Washington DC, June 2-3, 1992, pp. 22-28.
- Brooks, Rodney A. 1986. "A Robust Layered Control System for a Mobile Robot," IEEE Journal of Robotics and Automation, vol. RA-2 no. 1, March 1986, pp. 14-23.
- Brutzman, Donald P. 1992a. *NPS AUV Integrated Simulator*, Master's Thesis, Naval Postgraduate School, Monterey, California, March 1992.
- Brutzman, Donald P., Kanayama, Yutaka, and Zyda, Michael J. 1992b. "Integrated Simulation for Rapid Development of Autonomous Underwater Vehicles", *Proceedings of the IEEE Oceanic Engineering Society Conference AUV 92*, Washington DC, June 2-3, 1992, pp. 3-10.
- Brutzman, Donald P., Compton, Mark A. and Kanayama, Yutaka. 1992c. "Autonomous Sonar Classification using Expert Systems," *Proceedings of the IEEE Oceanic Engineering Society Conference OCEANS 92*, Newport, Rhode Island, October 26-29, 1992.

- Brutzman, Donald P. and Compton, Mark A. 1991. "AUV Research at the Naval Postgraduate School," *Sea Technology*, vol. 32 no. 12, December 1991, pp. 35-40.
- Byrnes, R.B., MacPherson, D.L., Kwak, S.H., McGhee, R.B. and Nelson, M.L. 1992. "An Experimental Comparison of Hierarchical and Subsumption Software Architectures for Control of an Autonomous Underwater Vehicle," *Proceedings of the IEEE Oceanic Engineering Society Conference AUV 92*, Washington DC, June 2-3, 1992, pp. 135-141.
- Elfes, Alberto. 1986. "A distributed control architecture for an autonomous mobile robot," *Artificial Intelligence*, vol. 1 no. 2.
- Etter, Paul C. 1991. *Underwater Acoustic Modeling: Principles, Techniques and Applications*, Elsevier Applied Science, London, England.
- Healey, A.J., McGhee, R.B., Cristi, F., Papoulias, F.A., Kwak, S.H., Kanayama, Y., Lee, Y., Shukla, S. and Zaky, A. 1992. "Research on Autonomous Underwater Vehicles at the Naval Postgraduate School," *Naval Research Reviews*, Naval Research Laboratory, Washington DC, vol. XLIV no. 1.
- Iyengar, S. Sitharama and Elfes, Alberto, ed. 1991. *Autonomous Underwater Robots: Perception, Mapping and Navigation*, volume 1, IEEE Computer Society Press, Los Alamitos, California.
- Iyengar, S. Sitharama and Elfes, Alberto, ed. 1991. *Autonomous Underwater Robots: Control, Planning and Architecture*, volume 2, IEEE Computer Society Press, Los Alamitos, California.
- Kwak, S.H., McGhee, R.B. and Bihari, T.E. 1992. "Rational Behavior Model: A Tri-level Multiple Paradigm Architecture for Robot Vehicle Control Software," technical report NPS-CS-92-003, Naval Postgraduate School, Monterey, California, March 1992.
- Moravec, Hans. 1983. "The Stanford Cart and the CMU Rover," *Proceedings of the IEEE*, vol. 71 no. 7, July 1983, pp. 872-884.
- Moravec, Hans. 1988. *Mind Children*, Harvard University Press, Cambridge Massachusetts, p. 48.
- Pappas, George, Shotts, William, O'Brien, Mack and Wyman, William. 1991. "The DARPA/Navy Unmanned Undersea Vehicle Program," *Unmanned Systems*, vol. 9 no. 2, Spring 1991, pp. 24-30.
- Payton, David W. and Bihari, Thomas E. 1991. "Intelligent Real-Time Control of Robotic Vehicles," *Communications of the ACM*, vol. 34 no. 8, August 1991, pp. 49-63.
- Pentland, Alex P. 1990. "Computational Complexity Versus Simulated Environments," *Computer Graphics Special Issue: 1990 Symposium on Interactive 3D Graphics*, Snowbird, Utah, March 25-28, 1990, ACM Press, New York.
- Pratt, David R., Zyda, Michael J., Mackey, Randall L. and Falby, John S. 1992. "NPSNET: A Networked Vehicle Simulation with Hierarchical Data Structures," *Proceedings of the Image VI Conference*, Image Society Inc., Scottsdale, Arizona, July 14-17, 1992, pp. 216-225.
- Rheingold, Howard. 1991. *Virtual Reality*, Summit Books, New York.
- Spector, Lee and Hendler, James. 1991. "The Supervenience Architecture," AAAI Fall Symposium on Sensory Aspects of Robotic Intelligence, Asilomar Conference Center, Pacific Grove, California, November 15-17, 1991, pp. 93-100.
- Yuh, J. 1990. "Modeling and Control of Underwater Robotic Vehicles," *IEEE Transactions on Systems, Man and Cybernetics*, vol. 20 no. 6, November/December 1990, pp. 1475-1483.
- Zyda, M.J., McGhee, R.B., Kwak, S.H., Nordman, D.B., Rogers, R.C. and Marco, D. 1990. "Three-Dimensional Visualization of Mission Planning and Control for the NPS Autonomous Underwater Vehicle," *IEEE Journal of Oceanic Engineering*, vol. 15 no. 3, July 1990, pp. 217-221.
- Zyda, Michael J., Jurewicz, Thomas A., Floyd, Charles A. and McGhee, Robert B. 1991. "Physically Based Modeling of Rigid Body Motion in a Real-Time Graphical Simulator," unpublished paper, Naval Postgraduate School, Monterey, California, September 1991.
- Zyda, Michael J. and Pratt, David R. 1992. "NPSNET Digest: A Look at a 3D Visual Simulator for Virtual World Exploration and Experimentation," *Proceedings of the 1992 EFDPM Conference on Virtual Reality*, Washington DC, June 1-2, 1992.

# NPS AUV Hardware and Software Configuration

August 17, 1993

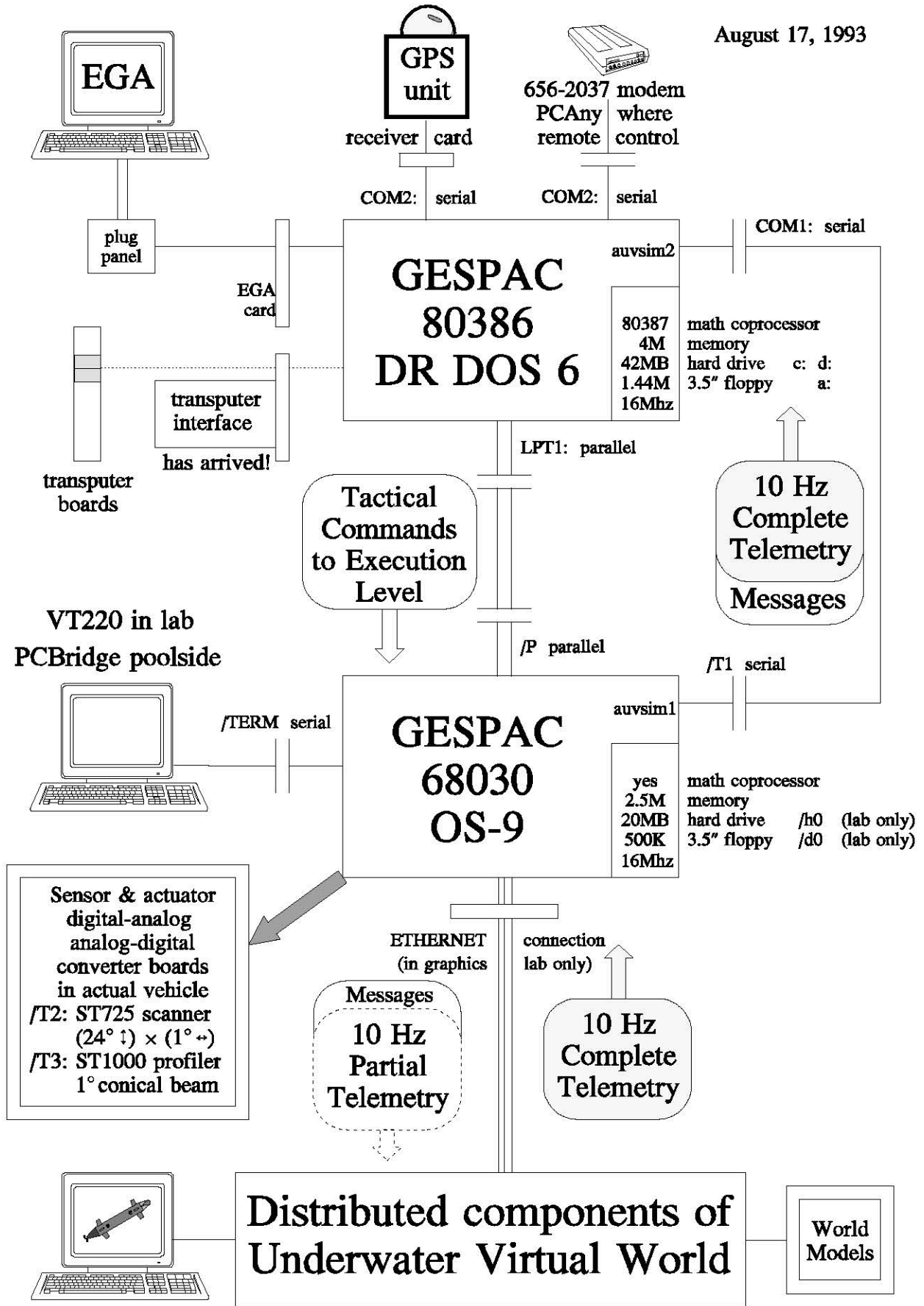

# Distributed Process Communications NPS AUV Underwater Virtual World

August 17, 1993

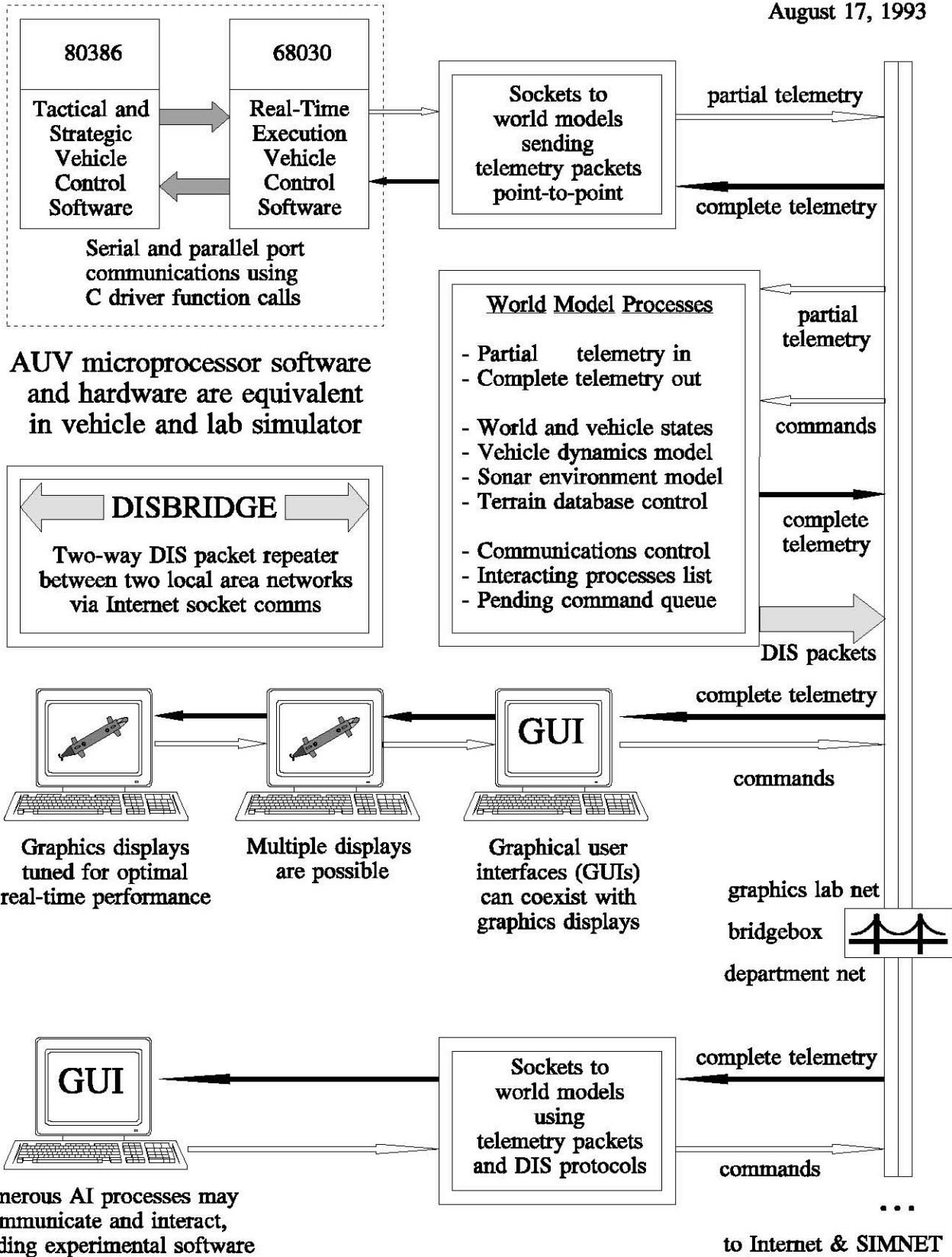



# NPS AUV Underwater Virtual World

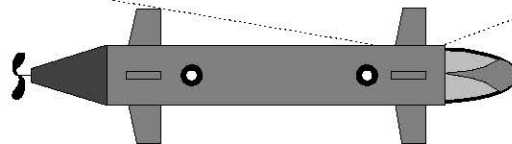
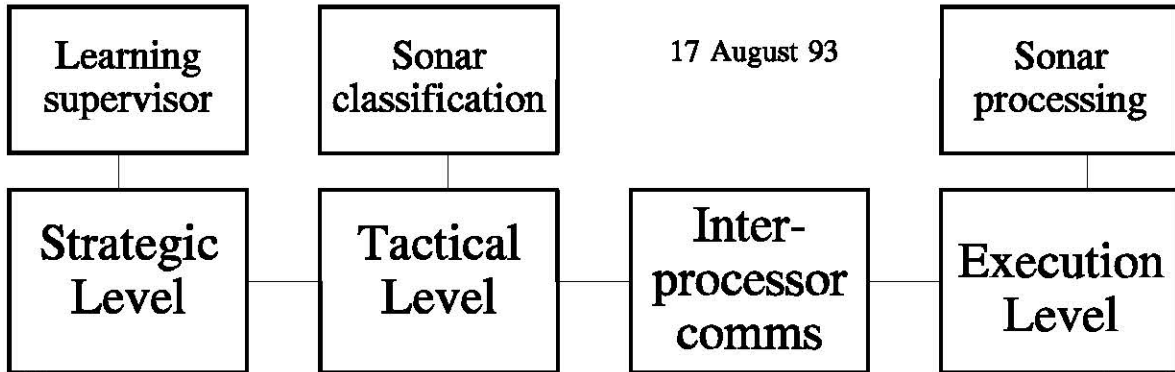

Lab microprocessors or actual AUV

