



## Calhoun: The NPS Institutional Archive

---

Theses and Dissertations

Thesis Collection

---

2013-12

# The evolution of the Civil Affairs force

Ferry, John V.

Monterey, California: Naval Postgraduate School

---

<http://hdl.handle.net/10945/38928>



Calhoun is a project of the Dudley Knox Library at NPS, furthering the precepts and goals of open government and government transparency. All information contained herein has been approved for release by the NPS Public Affairs Officer.

**Dudley Knox Library / Naval Postgraduate School**  
**411 Dyer Road / 1 University Circle**  
**Monterey, California USA 93943**

<http://www.nps.edu/library>



**NAVAL  
POSTGRADUATE  
SCHOOL**

**MONTEREY, CALIFORNIA**

**THESIS**

**THE EVOLUTION OF THE CIVIL AFFAIRS FORCE**

by

John V. Ferry  
Benny H. Romero

December 2013

Thesis Co-advisors:

George Lober  
Camber Warren

**Approved for public release; distribution is unlimited**

THIS PAGE INTENTIONALLY LEFT BLANK

<b>REPORT DOCUMENTATION PAGE</b>			<i>Form Approved OMB No. 0704-0188</i>
Public reporting burden for this collection of information is estimated to average 1 hour per response, including the time for reviewing instruction, searching existing data sources, gathering and maintaining the data needed, and completing and reviewing the collection of information. Send comments regarding this burden estimate or any other aspect of this collection of information, including suggestions for reducing this burden, to Washington headquarters Services, Directorate for Information Operations and Reports, 1215 Jefferson Davis Highway, Suite 1204, Arlington, VA 22202-4302, and to the Office of Management and Budget, Paperwork Reduction Project (0704-0188) Washington, DC 20503.			
<b>1. AGENCY USE ONLY (Leave blank)</b>	<b>2. REPORT DATE</b> December 2013	<b>3. REPORT TYPE AND DATES COVERED</b> Master's Thesis	
<b>4. TITLE AND SUBTITLE</b> THE EVOLUTION OF THE CIVIL AFFAIRS FORCE		<b>5. FUNDING NUMBERS</b>	
<b>6. AUTHOR(S)</b> John V. Ferry and Benny H. Romero			
<b>7. PERFORMING ORGANIZATION NAME(S) AND ADDRESS(ES)</b> Naval Postgraduate School Monterey, CA 93943-5000		<b>8. PERFORMING ORGANIZATION REPORT NUMBER</b>	
<b>9. SPONSORING /MONITORING AGENCY NAME(S) AND ADDRESS(ES)</b> N/A		<b>10. SPONSORING/MONITORING AGENCY REPORT NUMBER</b>	
<b>11. SUPPLEMENTARY NOTES</b> The views expressed in this thesis are those of the author and do not reflect the official policy or position of the Department of Defense or the U.S. Government. IRB Protocol number ___N/A___.			
<b>12a. DISTRIBUTION / AVAILABILITY STATEMENT</b> Approved for public release; distribution is unlimited		<b>12b. DISTRIBUTION CODE</b> A	
<b>13. ABSTRACT (maximum 200 words)</b>  Beginning with the United States (U.S.)-Mexican War in 1846 and continuing to the most recent combat operations in Afghanistan and Iraq, United States military history has repeatedly shown the importance of civil affairs operations: that is, shaping the civil component of the operational environment. During this span, civil affairs operations have evolved from operations conducted only by combat units to those conducted by a dedicated Civil Affairs force. The demand for Civil Affairs has increased significantly since September 11, 2001, and in response to that demand, the Army has attempted to grow the Civil Affairs force in both the active and reserve components. The rapid growth in demand for Civil Affairs has led to the creation of a Civil Affairs force composed of one active-duty Civil Affairs special-operations brigade, one active-duty Civil Affairs brigade for conventional forces, and nine reserve civil affairs brigades. The current Civil Affairs force structure is subordinate to three commands: the U.S. Army Special Operations Command, U.S. Forces Command, and the U.S. Army Reserve Command.  This thesis analyzes the current Civil Affairs force structure within the active and reserve components by using three metrics: training efficiency, organizational efficiency, and operational efficiency. It addresses the question of whether the current Civil Affairs structure reflects the most efficient design, and if not, what changes are needed to improve efficiency.			
<b>14. SUBJECT TERMS</b> Civil Affairs, Force Structure, 95th Civil Affairs Brigade (A), 85th Civil Affairs Brigade, U.S. Army Civil Affairs and Psychological Operations Command, Unification, Unity of Effort, Operational Efficiency, Organizational Efficiency, Training Efficiency, Network		<b>15. NUMBER OF PAGES</b> 115	
		<b>16. PRICE CODE</b>	
<b>17. SECURITY CLASSIFICATION OF REPORT</b> Unclassified	<b>18. SECURITY CLASSIFICATION OF THIS PAGE</b> Unclassified	<b>19. SECURITY CLASSIFICATION OF ABSTRACT</b> Unclassified	<b>20. LIMITATION OF ABSTRACT</b> UU

THIS PAGE INTENTIONALLY LEFT BLANK

**Approved for public release; distribution is unlimited**

**THE EVOLUTION OF THE CIVIL AFFAIRS FORCE**

John V. Ferry  
Major, United States Army  
B.A., Mississippi State University, 1998

Benny H. Romero  
Major, United States Army  
B.A., Texas State University, San Marcos, 2001

Submitted in partial fulfillment of the  
requirements for the degree of

**MASTER OF SCIENCE IN DEFENSE ANALYSIS**

from the

**NAVAL POSTGRADUATE SCHOOL  
December 2013**

Authors: John V. Ferry

Benny H. Romero

Approved by: George Lober  
Thesis Co-advisor

Camber Warren  
Thesis Co-advisor

John Arquilla  
Chair, Department of Defense Analysis

THIS PAGE INTENTIONALLY LEFT BLANK

## **ABSTRACT**

Beginning with the United States (U.S.)–Mexican War in 1846 and continuing to the most recent combat operations in Afghanistan and Iraq, United States military history has repeatedly shown the importance of civil affairs operations: that is, shaping the civil component of the operational environment. During this span, civil affairs operations have evolved from operations conducted only by combat units to those conducted by a dedicated Civil Affairs force. The demand for Civil Affairs has increased significantly since September 11, 2001, and in response to that demand, the Army has attempted to grow the Civil Affairs force in both the active and reserve components. The rapid growth in demand for Civil Affairs has led to the creation of a Civil Affairs force composed of one active-duty Civil Affairs special-operations brigade, one active-duty Civil Affairs brigade for conventional forces, and nine reserve civil affairs brigades. The current Civil Affairs force structure is subordinate to three commands: the U.S. Army Special Operations Command, U.S. Forces Command, and the U.S. Army Reserve Command.

This thesis analyzes the current Civil Affairs force structure within the active and reserve components by using three metrics: training efficiency, organizational efficiency, and operational efficiency. It addresses the question of whether the current Civil Affairs structure reflects the most efficient design, and if not, what changes are needed to improve efficiency.



THIS PAGE INTENTIONALLY LEFT BLANK

# TABLE OF CONTENTS

<b>I.</b>	<b>INTRODUCTION.....</b>	<b>1</b>
<b>A.</b>	<b>BACKGROUND .....</b>	<b>1</b>
<b>B.</b>	<b>RESEARCH QUESTION .....</b>	<b>4</b>
<b>C.</b>	<b>HYPOTHESIS.....</b>	<b>4</b>
<b>D.</b>	<b>LITERATURE REVIEW .....</b>	<b>4</b>
<b>E.</b>	<b>THEORY .....</b>	<b>9</b>
<b>F.</b>	<b>METHODOLOGY .....</b>	<b>11</b>
<b>II.</b>	<b>ANALYSIS OF CURRENT CIVIL AFFAIRS FORCE STRUCTURE .....</b>	<b>13</b>
<b>A.</b>	<b>ORGANIZATIONAL EFFICIENCY.....</b>	<b>13</b>
<b>B.</b>	<b>TRAINING EFFICIENCY .....</b>	<b>15</b>
<b>C.</b>	<b>OPERATIONAL EFFICIENCY.....</b>	<b>16</b>
<b>III.</b>	<b>CASE STUDIES.....</b>	<b>19</b>
<b>A.</b>	<b>ORGANIZATIONAL EFFICIENCY–UNITED STATES NORTHERN COMMAND .....</b>	<b>19</b>
<b>1.</b>	<b>Organizational Efficiency.....</b>	<b>21</b>
<b>2.</b>	<b>Training and Exercises: Building Relationships.....</b>	<b>23</b>
<b>3.</b>	<b>Dual-Status Command in Action–Republican National Convention.....</b>	<b>25</b>
<b>4.</b>	<b>Waldo Canyon Fire–Colorado.....</b>	<b>26</b>
<b>5.</b>	<b>Conclusion .....</b>	<b>27</b>
<b>B.</b>	<b>TRAINING EFFICIENCY–CREATION OF THE DEPARTMENT OF HOMELAND SECURITY .....</b>	<b>27</b>
<b>1.</b>	<b>Flexible and Fast Training Response .....</b>	<b>29</b>
<b>2.</b>	<b>Cost Avoidance and Operational Efficiencies .....</b>	<b>32</b>
<b>C.</b>	<b>OPERATIONAL EFFICIENCY–THE DEPARTMENT OF DEFENSE REORGANIZATION ACT OF 1986 (GOLDWATER– NICHOLS ACT) .....</b>	<b>35</b>
<b>1.</b>	<b>Failed Iranian Rescue .....</b>	<b>36</b>
<b>2.</b>	<b>Marine Barracks Bombing.....</b>	<b>37</b>
<b>3.</b>	<b>GNA Objectives.....</b>	<b>37</b>
<b>4.</b>	<b>Gulf War .....</b>	<b>38</b>
<b>5.</b>	<b>Somalia.....</b>	<b>39</b>
<b>6.</b>	<b>Conclusion .....</b>	<b>40</b>
<b>IV.</b>	<b>CURRENT CIVIL AFFAIRS REORGANIZATION PROPOSALS .....</b>	<b>41</b>
<b>A.</b>	<b>PROPOSAL #1–ACTIVE DUTY CONSOLIDATION .....</b>	<b>41</b>
<b>B.</b>	<b>PROPOSAL #2–TITLE 10 COMMAND CONSOLIDATION.....</b>	<b>42</b>
<b>C.</b>	<b>PROPOSAL #3–ELIMINATION OF THE 85TH CIVIL AFFAIRS BRIGADE.....</b>	<b>43</b>
<b>V.</b>	<b>RECOMMENDATION.....</b>	<b>47</b>
<b>A.</b>	<b>DESCRIPTION.....</b>	<b>47</b>

<b>B.</b>	<b>OPERATIONAL</b> .....	<b>49</b>
<b>1.</b>	<b>CME Missions Sourced with More Emphasis on Phases 0 and 1</b> .....	<b>50</b>
<b>2.</b>	<b>Operationalized BDE HQ 1:1</b> .....	<b>50</b>
<b>C.</b>	<b>ORGANIZATIONAL</b> .....	<b>51</b>
<b>D.</b>	<b>TRAINING</b> .....	<b>52</b>
<b>E.</b>	<b>CHALLENGES TO IMPLEMENTATION</b> .....	<b>53</b>
<b>1.</b>	<b>Culture</b> .....	<b>53</b>
<b>2.</b>	<b>Qualification Standards Versus Civil Affairs</b> .....	<b>55</b>
<b>3.</b>	<b>Bill Payers</b> .....	<b>56</b>
<b>F.</b>	<b>CONCLUSION</b> .....	<b>56</b>
<b>APPENDIX A. CURRENT CIVIL AFFAIRS STRUCTURE</b> .....		<b>59</b>
<b>APPENDIX B. DEMAND SPECTRUM MATH</b> .....		<b>61</b>
<b>APPENDIX C. DEMAND SPECTRUM AND RESERVE CIVIL AFFAIRS</b> .....		<b>63</b>
<b>APPENDIX D. U.S. ARMY RESERVE, CIVIL AFFAIRS STRENGTH</b> .....		<b>65</b>
<b>APPENDIX E. CIVIL AFFAIRS QUALIFICATION COURSE RESERVE GRADUATES</b> .....		<b>67</b>
<b>APPENDIX F. RESERVE MISSION REQUIREMENTS</b> .....		<b>69</b>
<b>APPENDIX G. OPTIMIZED FORCE STRENGTH (RESERVES)</b> .....		<b>71</b>
<b>APPENDIX H. LITTLE’S SOURCING MATRIX</b> .....		<b>73</b>
<b>APPENDIX I. ROLE OF ARMY SPECIAL OPERATIONS</b> .....		<b>75</b>
<b>APPENDIX J. CIVIL AFFAIRS REORGANIZATION PROPOSAL #1 (ACTIVE DUTY CONSOLIDATION)</b> .....		<b>77</b>
<b>APPENDIX K. CIVIL AFFAIRS REORGANIZATION PROPOSAL #2 (TITLE 10 COMMAND CONSOLIDATION)</b> .....		<b>79</b>
<b>APPENDIX L. CIVIL AFFAIRS REORGANIZATION PROPOSAL #3 (ELIMINATION OF THE 85TH)</b> .....		<b>81</b>
<b>APPENDIX M. A UNIFIED MULTI-COMPONENT COMMAND</b> .....		<b>83</b>
<b>APPENDIX N. CIVIL AFFAIRS SPECIAL OPERATIONS COMMAND HEADQUARTERS</b> .....		<b>85</b>
<b>APPENDIX O. ARMY SERVICE COMPONENT COMMAND’S CIVIL AFFAIRS STAFF</b> .....		<b>87</b>
<b>APPENDIX P. FUNCTIONAL SPECIALTY COMPANY</b> .....		<b>89</b>
<b>LIST OF REFERENCES</b> .....		<b>91</b>
<b>INITIAL DISTRIBUTION LIST</b> .....		<b>97</b>

## **LIST OF TABLES**

Table 1.	Fayol's 14 Management Principles (from Wren & Bedeian, 1994, p. 217).....9
----------	--

THIS PAGE INTENTIONALLY LEFT BLANK

## LIST OF ACRONYMS AND ABBREVIATIONS

AAR	after action review
AC	active component
ACC	Army Capstone Concept
AIT	advanced individual training
ALCOM	Alaskan Command
AMEDD	U.S. Army Medical Department
ARFORGEN	Army Force Generation Cycle
ASCC	Army Service Component Command
ATRRS	Army Training Requirements and Resource System
BCT	brigade combat team
CA	civil affairs
CACOM	Civil Affairs Command
CAMS	Civil Affairs Medical Sergeant
CAO	civil affairs operations
CAPT	Civil Affairs Planning Team
CASOC	Civil Affairs Special Operations Command
CBP	U.S. Customs and Border Patrol
CBRN	chemical, biological, radiological, and nuclear
CCJO	Capstone Concept for Joint Operations
CENTCOM	U.S. Central Command
CINC	Commander-in-Chief
CJCS	Chairman of the Joint Chiefs of Staff
CME	Civil Military Engagement
CMO	civil–military operations
CMSE	Civil Military Support Element
CORDS	Civil Operations and Revolutionary Development Support
CTMD	Centralized Training Management Directorate
DHS	Department of Homeland Security
DoD	Department of Defense
DoDD	Department of Defense Directive
DOTMLPF	Doctrine, Organization, Training, Materiel, Leadership & Education, Personnel, and Facilities
DOTMLPF-P	Doctrine, Organization, Training, Materiel, Leadership & Education, Personnel, Facilities - Policy
DS	direct support
EUCOM	U.S. European Command

FBI	Federal Bureau of Investigation
FDU	force development update
FEMA	Federal Emergency Management Agency
FFDO	federal flight deck officer
FFI	Financial Fraud Institute
FLETC	Federal Law Enforcement Training Center
GAO	Government Accountability Office
GCC	Geographic Combatant Command
GNA	Goldwater–Nichols Act
GRF	Global Response Force
GSORTS	Global Status of Readiness and Training System
HA/DR	humanitarian assistance/disaster relief
HN	host nation
IMSG	Institute for Military Support to Governance
IPI	indigenous populations and institutions
JCET	Joint Combined Exchange Training
JFHQ-NCR	Joint Force Headquarters National Capital Region
JTF	joint task force
JTF-AK	Joint Task Force Alaska
JTF-CS	Joint Task Force Civil Support
JTF-N	Joint Task Force North
LED	light-emitting diode
MANPADS	man-portable air defense system
MEB	Maneuver Enhancement Brigade
MFP	Major Force Program
MOA	memorandum of agreement
MTOE	modified table of organization and equipment
NCO	non-commissioned officer
NGB	National Guard Bureau
NORAD	North American Aerospace Defense Command
NSSE	national special security event
OCO	other contingency operations
OEF-A	Operation Enduring Freedom–Afghanistan
OEF-KU	Operation Enduring Freedom–Kuwait
OMAR	Operations and Maintenance, Army Reserve
OOTW	operations other than war

PCS	permanent change of station
PE	persistent engagement
POI	program of instruction
QDR	Quadrennial Defense Review
RC	reserve component
RFF	request for forces
SACEUR	Supreme Allied Commander Europe
SOCM	Special Operations Combat Medic
SOCMS	Special Operations Combat Medic School
SOF	Special Operation Forces
SWC	Special Warfare Center
TSC	theater security cooperation
TSCP	Theater Security Cooperation Plan
TSOC	Theater Special Operations Command
UCP	Unified Command Plan
UN	United Nations
UNITAF	Unified Task Force
U.S.	United States
USACAPOC	U.S. Army Civil Affairs and Psychological Operations Command
USAJFKSWCS	U.S. Army John F. Kennedy Special Warfare Center and School
USAR	U.S. Army Reserve
USARC	U.S. Army Reserve Command
USAREUR	U.S. Army Reserve Europe
USARPAC	U.S. Army Reserve Pacific
USASFC	U.S. Army Special Forces Command
USASOC	U.S. Army Special Operations Command
USFORSCOM	U.S. Forces Command
USJFCOM	U.S. Joint Forces Command
USNORTHCOM	U.S. Northern Command
USPACOM	U.S. Pacific Command
USR	unit status reporting
USSOCOM	U.S. Special Operations Command
USSOUTHCOM	U.S. Southern Command



THIS PAGE INTENTIONALLY LEFT BLANK

## ACKNOWLEDGMENTS

We would like to first thank LTC Jay Liddick for challenging us with our thesis topic before our arrival at the Naval Postgraduate School, and we would also like to thank LTC Keith Pritchard for his assistance in helping us understand how the Army system works within the Pentagon. Their professional insights and encouragement have been invaluable.

We would like to thank our advisors, Professor George Lober and Dr. Camber Warren, for their teaching, coaching, and mentorship. With their assistance, we have attempted to provide a scholarly and objective thesis. Any mistakes in that effort are borne by the authors alone.

We would like to thank the many officers, non-commissioned officers and soldiers of the 95th Civil Affairs Brigade, 85th Civil Affairs Brigade, U.S. Army Civil Affairs and Psychological Operations Command, the U.S. Army John F. Kennedy Special Warfare Center and School, and the U.S. Army Special Operations Command for their assistance in our research.

Lastly, we would like to express our sincere appreciation to our families who have endured the many hours of schoolwork and research. To our wives, Sarah and Christina, we thank you for your generous patience and unwavering support. We love you.

THIS PAGE INTENTIONALLY LEFT BLANK

# I. INTRODUCTION

## A. BACKGROUND

The concept and importance of the civilian and governance domains during war can be traced back to Carl von Clausewitz's *On War*. In Section Nine of that work, he states that the outcome of war, or military victory, is never final. He argues that a defeated enemy rarely acknowledges defeat, but ascertains when the most opportune time and with what strategy to fight again (Handel, 1999). Therefore, post conflict, both the needs of the civilian populace and the issue of governance must be addressed to capitalize on military victory. In order to achieve final victory, a proper combination of military force and civil-military operations must exist. The U.S. Department of Defense (2013) states that civil-military operations:

are the activities of a commander performed by designated CA [Civil Affairs] or other military forces that establish, maintain, influence, or exploit relationships between military forces and IPI [indigenous populations and institutions], by directly supporting the attainment of objectives relating to the reestablishment or maintenance of stability within a region or HN [host nation]. (p. I-2)

The United States (U.S.) military has been conducting civil-military operations from the 19th century until the present. "Historians identify the U.S.-Mexican War as the first time the U.S. military conducted civil affairs/military government operations" (Hicks & Wormuth, 2009, p. 14). The occupation of Mexico required the creation of new operational and tactical approaches to achieve U.S. policy objectives. To achieve victory in Mexico, the occupying soldiers were required to conduct untraditional tasks that were not related to direct combat. "The Army's general-in-chief, Winfield Scott, devised occupation policies that initially emphasized conciliation toward the Mexican people and local officials" (Yates, 2006, p. 12). To do this, the military focused on local governance by supporting public institutions. The military's support of public institutions facilitated timely local elections and assisted the public institutions in providing basic services for the populace. That support began to legitimize the new government and assisted in stabilizing the region.

Conducting civil-military operations would continue throughout U.S. military history. Lessons learned from the U.S.-Mexican War were utilized by the Union a decade later during the Civil War. This trend of executing civil-military operations continued through the United States' series of small wars in the Caribbean, Philippines, and parts of Central America. The consistent need for a civil-military capable force, or a specified force to conduct those missions, exposed a military capability gap. The Department of the Army sought to fill that gap with doctrine and education. In the 1940s, *FM-27 Military Government* was published, the School of Government at the University of Virginia was established, and the Military Government Division of the Army was created. Shortly thereafter, the conclusion of World War II provided significant tests for both the new doctrine and the personnel recently educated in the execution of military governance operations. The occupations of, and nation-building efforts toward, Germany and Japan reflected distinct differences, but the same nation building blueprint was used for both countries. The military assisted in establishing an effective government at the local and national levels in order to set the conditions for “political, economic, and social recovery and reform” (Yates, 2006, p. 19).

In the 1950s, the Korean War provided another opportunity to evaluate the civil-military capability of the U.S. military and the importance of non-combat operations. The civil affairs operations in Korea assisted in validating the importance and role of such operations in the military. The U.S. Department of Defense (2013) states that civil affairs operations are:

actions planned, executed, and assessed by civil affairs forces that enhance awareness of and manage the interaction with the civil component of the operational environment; identify and mitigate underlying causes of instability within civil society; or involve the application of functional specialty skills normally the responsibility of civil government. (p. GL-6)

A myriad of programs were conducted to promote stability within Korea. The programs were created to improve public health, local security, and the rebuilding of critical infrastructure. The success story in Korea led to the creation of the Civil Affairs and Military Government Branch, U.S. Army Reserve in 1955 (Hicks & Wormuth, 2009, p. 16). The Civil Affairs branch and its role in military operations then continued to

evolve and increase during the Vietnam War. Civil Affairs involvement in the Civilian Irregular Defense Groups and the Civil Operations and Revolutionary Development Support (CORDS) program utilized similar health, education, and infrastructure programs to those executed in previous conflicts in order to address the displaced civilian population and recruit support to fight the Viet Cong.

This history led to the creation of the U.S. Army Civil Affairs and Physiological Operations Command (USACAPOC). USACAPOC was subordinate to U.S. Army Special Operations Command (USASOC) and had one active duty battalion, seven reserve brigades, and four Civil Affairs Commands (CACOM) organic to its organization. The need and demand for a dedicated Civil Affairs force has increased throughout the history of U.S. combat operations, and this has not changed during our most current operations. The counterinsurgencies fought in Afghanistan and Iraq have illuminated the importance of popular support in assisting conventional and special operations forces' efforts to defeat an insurgency. As shown by history, obtaining popular support can reduce the insurgent's base of support, freedom of maneuver, and recruitment from the population.

Due to the success of Civil Affairs in Afghanistan and Iraq, the Department of Defense (DoD) over the last 10 years has authorized the growth of both the active and reserve Civil Affairs forces and funded the increase of Civil Affairs capability in the latest 2010 Quadrennial Defense Review (QDR). Civil Affairs started under one subordinate command, USASOC. As both Civil Affairs components grew and the demand for Civil Affairs increased in both Afghanistan and Iraq, USASOC lacked the staff capability to manage all of the Title 10 responsibilities (Train, Man, Equip) for both the active and reserve components. This lack of capability supported the Secretary of Defense's justification for separating the reserve Civil Affairs force from the active duty Civil Affairs force in 2006. The separation placed Civil Affairs forces under two Civil Affairs commands: USACAPOC became subordinate to U.S. Army Reserve Command (USARC) for reserve Civil Affairs forces, and the 95th Civil Affairs Brigade (Airborne) became subordinate to USASOC for the active component Civil Affairs forces. Then in 2010, the 85th Civil Affairs Brigade was established to support conventional forces and is

a direct reporting unit to U.S. Forces Command (USFORSCOM) at Fort Bragg, North Carolina. Currently, the DoD's primary Civil Affairs capability is thus dispersed within three separate commands and two components (active and reserve). Unfortunately, the modern growth of Civil Affairs was not undertaken with a total Army vision of how to organize and structure civil affairs.

This thesis examines the current Civil Affairs force structure within the active and reserve components by utilizing three metrics; operational, organizational, and training efficiency. The purpose of the analysis is to determine whether the current Civil Affairs structure is the most efficient design, and if not, what changes need to occur to improve efficiency.

## **B. RESEARCH QUESTION**

What is the optimal Civil Affairs force structure that meets the intent and desired capability of U.S. Special Operations Command (USSOCOM), USFORSCOM, and the Department of the Army?

## **C. HYPOTHESIS**

Placing both the reserve and active duty Civil Affairs forces under one multi-component command will provide the highest level of organizational efficiency, training and education efficiency, and operational capability.

## **D. LITERATURE REVIEW**

Since both the 2006 separation and the subsequent growth of the second active duty Civil Affairs brigade in 2010, five professional or academic Civil Affairs reports have been published that address the need to restructure the entire active and reserve Civil Affairs force. The authors of these works have utilized differing methods of evidence to support their claims. However, the most widely quoted and referenced report within the Civil Affairs community on reorganizing the Civil Affairs force is the Center for Strategic and International Studies' report titled, *The Future of U.S. Civil Affairs Forces*. Written in 2009 by Kathleen Hicks and Christine Wormuth, the report first addresses the importance of Civil Affairs to the counterinsurgency efforts within

Afghanistan and Iraq before identifying shortfalls within the current force structure and recommending solutions to strengthen the Defense Department's Civil Affairs capability. Hicks and Wormuth (2009) recommended that the Defense Department undertake the following corrective actions:

- Reintegrate all Army Civil Affairs forces under U.S. Army Special Operations Command and create within USASOC a one or two-star active Civil Affairs general officer to oversee and advocate for all Army Civil Affairs forces.
- Embed Civil Affairs expertise in key strategic organizations throughout the department and across the U.S. government. This includes the Office of the Secretary of Defense, the Joint Staff, the Army staff, and Combatant Command headquarters, as well as the State Department, U.S. embassies overseas, and the U.S. Agency for International Development.
- Ensure additional training for Civil Affairs personnel in strategic and operational Civil Affairs competencies.
- Fully implement the decision to establish Civil Affairs as a branch of the U.S. Army and ensure upward mobility for civil affairs personnel.
- Significantly deepen general purpose and special operations forces' understanding of the capabilities and application of Civil Affairs forces.
- Create an active component Civil Affairs structure to integrate at all echelons (division/equivalent and below) in Army, Navy, and Marine Corps.
- Link all new accession, track officer and enlisted personnel areas of civilian expertise to the appropriate Civil Affairs functional specialty areas.
- Ensure Civil Affairs functional specialty skills are included in the Global Status of Readiness and Training System (GSORTS) to facilitate force management of functional specialists.
- Require Civil Affairs personnel with identified functional specialties to take appropriate civil sector competency tests to validate and classify the achieved level of functional skills.

In March 2009, Lieutenant Colonel Miguel Castellanos, a reserve Civil Affairs officer, authored *Civil Affairs—Building the Force to Meet Its Future Challenges* as his Strategy Research Project at the U.S. Army War College. He begins by examining the



evolution of Civil Affairs since September 11, 2001 in the context of the major operations being conducted in Iraq and Afghanistan. Castellanos (2009) concludes by offering the following recommendations:

- Focus on filling the personnel shortfalls within U.S. Army Civil Affairs and Psychological Operations Command: “A potential start to mitigate this problem is to reassign as many IRR [Individual Ready Reserve] and USARC [U.S. Army Reserve Command] Soldiers, who mobilized as CA [Civil Affairs] Soldiers to USACAPOC units.” (p. 16)
- Establish incentives to recruit and retain Civil Affairs personnel to include functional specialists.
- Transition the specified proponent of Civil Affairs, U.S. John F. Kennedy Special Warfare Center and School Army to a branch proponent.
- Establish one command for Civil Affairs: “The CA [Civil Affairs] force of the future needs to be intertwined as one force, each complementing each other’s capabilities.” (p. 18)
- Create habitual relationships between the reserve Civil Affairs units and the active duty conventional Brigade Combat Teams that they would support during training and wartime operations.

In December 2009, Major Kurt Sisk, an active duty Civil Affairs officer, authored *House Divided: The Splitting of Active Duty Civil Affairs Forces* as his thesis at the Naval Postgraduate School. Sisk (2009) asserts that the placement of the 85th Civil Affairs Brigade within U.S. Forces Command “will not adequately meet short-term needs, and ultimately that more harm than good will come to the Civil Affairs branch from this action” (p. 1). He concludes with the following recommendations:

- Place all Civil Affairs forces under U.S. Army Special Operations Command (USASOC) within a single command.
- Align reserve Civil Affairs units with active duty conventional units for habitual support relationships.
- Remove active duty Civil Affairs personnel from active duty Brigade Combat Teams and allow reserve Civil Affairs personnel to fill those positions.
- Educate the conventional force (capabilities and limitations of Civil Affairs and rudimentary Civil Affairs activities).
- Conduct a comprehensive study of reserve Civil Affairs in order to eliminate non-essential requirements that are currently placed on reserve Civil Affairs.

- In April 2010, Major Samuel Simpson, also an active duty Civil Affairs officer, authored *Restructuring Civil Affairs for Persistent Engagement* at the School of Advanced Military Studies. Simpson reviews contemporary national strategy and creates a macro-level demand model for Civil Affairs. He concludes that the current Civil Affairs force structure will not support continued protracted conflict and provides the following recommendations:
  - One single command for Civil Affairs forces within USASOC.
  - Increasing active duty Civil Affairs forces to six brigades.
  - Restructuring reserve Civil Affairs in order to create more companies and eliminate the higher headquarter units.

In March 2012, Lieutenant Colonel Scot Storey, a Civil Affairs officer, authored *Rebalancing Civil Affairs: The Key to Military Governance* as his Strategy Research Project at the U.S. Army War College. He begins by examining the practicality of military governance in light of historical post-conflict successes and the contemporary requirement for post-hostility governance. Storey (2012) concludes by offering the following recommendations:

- Reunite the Civil Affairs regiment into a single multi-component command.
- Develop the capacity for military governance from within the current Civil Affairs structure (a military governance organization, a Military Occupational Specialty and Area of Concentration for Military Governance, military governance doctrine).
- Develop the ability to recruit, train and validate functional specialist.
- Reassign the four Civil Affairs Commands (CACOM) to the Geographic Combatant Commanders (GCC).

Although there are some consistent themes within these five works, the authors employ different methodologies and provide different recommendations. All of the works state that a unified multi-component Civil Affairs command is required to improve the capability of Civil Affairs. However, while four of the authors agree that the Civil Affairs command should be placed within USASOC, Castellanos (2009) does not specify where the command should reside. Based on his recommendation to create a Civil Affairs branch proponent outside of its current location within the U.S. Army John F. Kennedy Special Warfare Center and School (USJFKSWCS), the reader may logically conclude

that Castellanos is recommending the command reside in USFORSCOM (Castellanos, 2009). Similarly, although four of the five authors assert that the Civil Affairs force should restructure or optimize, Sisk (2009) argues that the Civil Affairs force should be dramatically increased within both the active and reserve forces. As stated, there are common threads within all of the force restructuring proposals, but none has provided quantitative evidence to support a feasible proposal. One proposal focuses on mathematical modeling with highly restrictive assumptions, another focuses on interviews, and the majority of the proposals rely on anecdotal and subjective evidence to support their claims. However, the consensus is that a Civil Affairs force structure change is required. Exactly what that change is, though, and how it should be implemented, varies widely.

To date, the absence of rigorous metrics of evaluation has impeded the implementation of any of the proposed force structures. Organizational change is further stifled by proposals that have been perceived, rightly or wrongly, as biased in favor of either the active duty or reserve force, without objective evidence to support the force structure or required capabilities. This lack of an objective means by which to evaluate force structure proposals has hindered the implementation of any proposed reorganization of the Civil Affairs force.

The authors of this thesis will analyze three widely known force structure proposals from the Civil Affairs community, in addition to offering the authors' own proposal, and utilize the criteria of operational, training, and organizational efficiency to objectively assess each proposal. The thesis will then provide a recommendation that is supported by objective evidence that includes both metrics and analogous case studies. The case studies will focus on military and government organizations that have unified their structure to improve the metrics of operational, organizational, and training efficiency. Proposed force structures will be required to meet the current and future requirements of the Army and each structure will be assessed with a common set of criteria. These proposals will also be viewed within the context of the U.S. government's

current fiscal environment and anticipated impact to both active and reserve personnel. The authors will close with a recommendation for an optimized Civil Affairs force structure.

## E. THEORY

Henri Fayol is considered by some to be “the father of operational management concepts,” and his management principles are the foundation for organizational change to the U.S. Army’s Civil Affairs force (Wren & Bedeian, 1994). Fayol provided the 14 principles for management in Table 1. These 14 principles are each relevant and applicable to today’s civil affairs organization within the U.S. Army. Of particular importance are Unity of Command and Unity of Direction, which will form the focus of the analysis presented here, though we will see that other principles, such as Order and Stability of Tenure, are also relevant. Drawing on Fayol’s principles, we argue that the Civil Affairs units currently within the U.S. Army—the 95th Civil Affairs Brigade (A) (active component), the 85th Civil Affairs Brigade (active component), and USACAPOC (reserve component)—will clearly require more effective implementation of Unity of Command and Unity of Direction to become a more efficient force.

Unity of Command	Centralization
Authority	Line of Authority
Discipline	Order
Division of Work	Equity
Unity of Direction	Stability of Tenure of Personnel
Subordination of individual to General Interests	Initiative
Remuneration	Esprit de corps

Table 1. Fayol’s 14 Management Principles (from Wren & Bedeian, 1994, p. 217)

Fayol's principle of Order refers to the efficient use of resources, specifically personnel and material, and is quite evident in the 2010 U.S. National Security Strategy (White House, 2010, pp. 34–35). The 2012 Defense Strategic Guidance is fully nested with the current National Security Strategy and states the following: “[we] must continue to reduce the ‘cost of doing business’ . . . examine the mix of Active Component (AC) and Reserve Component (RC) elements best suited for the strategy” (U.S. Department of Defense, 2012, p. 7). The National Military Strategy echoes the Defense Strategic Guidance and specifically mentions the following two points: (1) the importance of the RC and their operational employment for anticipated deployments and (2) simplifying the process of identifying capabilities to requirements (U.S. Department of Defense, 2011b). The Capstone Concept for Joint Operations (CCJO) and the Army Capstone Concept (ACC) provide continued focus on the new status quo of fiscal constraints and the requirement for interdependence of special operation forces and conventional forces (U.S. Department of Defense, 2011a; U.S. Army, 2010).

Fayol's principle of Stability of Tenure of Personnel refers to the “orderly human-resource staffing and establishing [of] provisions to ensure that a firm's employees possessed the requisite abilities for the work to be performed” (Wren & Bedeian, 1994, p. 222). For the purpose of this thesis, the authors will treat training, education, professional development, and assignment to key development positions as the central components of this longstanding principle. In September 2012, the Secretary of the Army established the “Total Force” concept within Army Directive 2012–08 that fully integrates the AC and the RC as “an integrated operational force to provide predictable, recurring and sustainable capabilities” (p. 1). The directive further directs one qualification or training standard for both the AC and RC personnel (Secretary of the Army, 2012, p. 2) and indicates that Reserve Civil Affairs units must be able to successfully conduct operations within a Joint Task Forces on par with an active duty Civil Affairs unit.

The goal of most organizations is to efficiently provide a quality product to the end user. In this particular case, the Civil Affairs force is attempting to efficiently provide effective Civil Affairs capabilities to accomplish the objectives of the Geographic Combatant Commanders (GCC). The largest challenge to that goal of efficiently

providing effective Civil Affairs capabilities to GCCs, is the current force structure. This force structure, in a number of respects, stands in direct violation of the principles, originally articulated by Fayol, inhibiting the production of Unity of Command and Unity of Direction, reducing Order, and lessening the Stability of Tenure of Personnel. In order to enhance the Army's Civil Affairs capability, we argue that the Army must instead work to internalize these timeless principles by restructuring the Civil Affairs force.

## **F. METHODOLOGY**

The Army utilizes the acronym DOTMLPF as a “problem-solving construct for assessing current capabilities and managing change” (U.S. Army, 2005, p. 4–11). DOTMLPF refers to Doctrine, Organizations, Training, Materiel, Leadership and Education, Personnel, and Facilities. “Change deliberately executed across DOTMLPF elements enables the Army to improve its capabilities to provide dominant landpower to the joint force” (p. 4–11). For the purposes of this thesis, the authors have selected specific criteria that have been derived from the DOTMLPF process to assess four Civil Affairs force structures: the current Civil Affairs force structure with three commands, a two-command force structure based on separate components (active and reserve), a single multi-component Civil Affairs command, and the authors' own proposed single multi-component command that has been optimized to meet Army Civil Affairs requirements. The authors have selected operational efficiency, training efficiency, and organizational efficiency as the key criteria through which to measure and compare those three force structures.

Operational efficiency is narrowly focused within the personnel section of the DOTMLPF process. The data collected for this criterion range from mission requirements to unit manning per organization. These data have been drawn from the organizations themselves (85th, 95th, USACAPOC) and Army personnel management systems, including the Personnel Electronic Management System.

The metric of training efficiency correlates to the training section of the DOTMLPF process. The data collected reflects the number of personnel by rank who are trained annually by the reserve and active components and the programs of instruction for

all schools that qualify soldiers to enter Civil Affairs. The sources of these data include the Army Training Requirements and Resource System (ATRRS), and all Civil Affairs qualification schools.

The metric of organizational efficiency correlates to the organization section of the DOTMLPF process. The information collected includes the following:

- Historical documents initially drawn to justify the force structure of USACAPOC and the active duty Civil Affairs brigades.
- Title 10 and mission requirements within current doctrine for each organization. These have been analyzed in order to identify any duplication of effort or other inefficiencies.
- Identified command relationships that exist within the current and proposed Civil Affairs force.

The sources of data include the Total Army Analysis that was utilized to build the Civil Affairs force, historical Quadrennial Defense Reviews (QDR), current Civil Affairs doctrine, and information from the three current organizations. The procedures for all three criteria involved descriptive statistics based upon unit documents. In addition to the descriptive statistics, the authors have conducted critical analysis of strategic documents from the Executive Branch, as well as the published guidance and directives from the DoD.

## **II. ANALYSIS OF CURRENT CIVIL AFFAIRS FORCE STRUCTURE**

The current force structure (Appendix A) of two active duty brigades, nine reserve brigades, and four Civil Affairs Commands (CACOM) is a result of the last Total Army Analysis conducted by the Department of the Army. The analysis was conducted when the Iraq and Afghanistan conflicts were both being executed and demand for all forces was at a peak. The “Total Army Analysis process ... incorporates DoD strategy and approved integrated security posture, [sic] the Army identified and resourced civil affairs force structure to meet the enduring rotational commitments” (Office of the Assistant Secretary of Defense for Special Operations, Low Intensity Conflict & Interdependent Capabilities, 2009, p. 7). The analysis found that each of the three Army Corps should receive a brigade headquarters, each of the 10 Army Divisions is allocated a civil affairs battalion headquarters, and each Brigade Combat Team (BCT) and Maneuver Enhancement Brigade (MEB) is provided a civil affairs company. The analysis also assisted in obtaining the authorization to increase the active duty Civil Affairs force by one brigade and the U.S. Army Civil Affairs and Psychological Operations Command (USACAPOC) by two brigades. However, the current Civil Affairs force structure faces substantial inefficiencies, in terms of organization, training, and operations. We will consider each in turn.

### **A. ORGANIZATIONAL EFFICIENCY**

It is intuitive to conclude that having three organizations that provide similar capabilities residing subordinate to three different commands in both the active and reserve components is not organizationally efficient. Having this organizational structure within an immature branch has impacted the growth and development of the total civil affairs force. Civil affairs officially became a branch in 2006 and has been evolving its capability ever since. What has remained constant is that the U.S. Army John F. Kennedy Special Warfare Center and School (USAJFKSWCS), subordinate to U.S. Army Special Operations Command (USASOC), has been the proponent for all Army civil affairs forces in USASOC, U.S. Forces Command (USFORSCOM), and USACAPOC. This has



forced the Civil Affairs proponent to be “responsible for determining and integrating the Doctrine, Organization, Training, Materiel, Leadership, Personnel, and Facilities –Policy (DOTMLPF-P) functions for Army civil affairs across the full spectrum of conventional and special operations” (Moore, 2012, p. 4). This arrangement has created friction between the two active duty Civil Affairs units and USAJFKSCS. USAJFKSCS, the generating force for all active duty Civil Affairs, has to manage manning requirements for both units. The Civil Affairs proponent has to balance manning both the special operations brigade to meet mission priorities and the Army manning policies that mandate new units be operational at or a prescribed number of days past their effective date. Unfortunately, during the growth of the second active duty brigade and the Force Development Update (FDU) of the 95th Civil Affairs Brigade, the generating force was not grown to increase the annual output of Civil Affairs qualified enlisted and officer personnel. The current annual output for officers is approximately 145, and enlisted annual output is approximately two hundred forty-two. Thus, without an adjustment to the size of the active force, manning will be an issue for the foreseeable future.

The size of the reserve force is also not organized efficiently to meet the reserve mission of supporting conventional forces. The current size of four civil affairs Commands, 9 brigades, 33 battalions, and 132 companies far exceeds the needed force for the Army’s current force structure and the future Army reduction of forces (Appendix B). By doctrine and the Total Army Analysis (TAA), each active and reserve BCT and MEB is allocated one civil affairs company. The projected future BCT and MEB totals will be 35 active and 47 reserve brigades. This means that even during future full surge conditions, with the 1:1 deployment to dwell-time ratio for the active force, and the 1:3 deployment to dwell-time ratio for the reserve force, mandated by current Department of the Army policies, reserve Civil Affairs force could reduce 49 percent of their companies without any impact to operations (Appendix C). In this way, the reserve and active Civil Affairs forces could be organized more efficiently both to reduce the impact on the generating force and to eliminate the budget for unnecessary units, while maintaining maximum effectiveness.

## **B. TRAINING EFFICIENCY**

The current force structure does not promote the efficient use of resources. Each unit or component is only concerned with its internal resource use. The lack of a unified civil affairs structure fosters resource competition among the components, which results in less efficient resource management. An example of inefficient resource use is the training of USACAPOC Civil Affairs officers by USAJFKSWCS. Only 36 percent of the officers sent by USACAPOC to receive civil affairs training return to a civil affairs unit or fill a civil affairs billet, based on data drawn from the Army Training Requirements and Resource System (ATRRS) and USACAPOC as of January 2011 (Appendix D). As of this date, USACAPOC had filled 207 of the authorized 1,050 Captains positions, or approximately 20 percent. In contrast, the ATRRS data from 2008 to 2011 show that the number of filled Captains positions should be closer to 90 percent. Moreover, if we assume that officers were trained at the same rate in 2006 and 2007 (where ATRRS data is lacking), as they were from 2008 to 2011, it can be estimated that from 2006 to 2011 the Army Reserves trained 1,044 First Lieutenants (Promotable) or Captains (see Appendix E). Subtracting from that 1,044 total the 207 currently on hand suggests that 837-trained Captains are not filling civil affairs positions.

Unfortunately, applying attrition or promotion rates does not significantly improve the statistic. Applying the reserve 16.5 percent attrition rate (Kapp, 2012) to the 1,044, Captains trained, results in 665 Civil Affairs Captains positions still not being filled. One argument for the shortage of Captains is that most were promoted. However, if the Captains were promoted, the Majors numbers would be better than the current 44 percent filled of the 653 authorized positions. The data suggests 64 percent of the First Lieutenants (Promotable) or Captains USAJFKSWCS trained and qualified are not filling reserve civil affairs vacancies. USAJFKSWCS has limited resources to train both active and reserve officers. Utilizing USAJFKSWCS resources to train and certify Civil Affairs officers who do not fill Civil Affairs billets is thus clearly an inefficient use of resources.

Of particular interest, though, are the reserve Staff Sergeants and Sergeants First Class. These reserve non-commissioned officers are not trained by USAJFKSWCS, but rather by the reserves at Fort Dix, New Jersey and Fort Hunter Liggett, California. Using

the same approach, we estimate that from 2006 to 2011 the Army Reserves trained 846 Civil Affairs Staff Sergeants, while in 2011, 557 of the 741 authorized Staff Sergeant positions were filled. Subtracting the 557 on hand from the 846 civil affairs Staff Sergeants trained, leaves 289-trained Staff Sergeants not filling civil affairs positions, or 149 if we apply the same 16.5 percent attrition rate. This suggests that only 18 percent of the reserves trained and qualified Staff Sergeants are not filling Civil Affairs vacancies. The Sergeants First Class data reveal similar percentages, indicating that only 25 percent of the trained and qualified reserve Sergeants First Class are not filling Civil Affairs vacancies.

We can thus observe a dramatic difference in how the USACAPOC leadership utilizes its own resources, in contrast to how it consumes the resources of other organizations. This comparison between the manning of reserve officers and non-commissioned officers illustrates the profound impact that structures of accountability can have on the allocation of resources. As we argue below, we must remain attentive to such dynamics as we consider the likely impacts of changes in the current Civil Affairs force structure.

### **C. OPERATIONAL EFFICIENCY**

The new forces added to the Civil Affairs force structure are not in a position to answer the operational demand signal for Civil Affairs forces. For example, the new 85th Civil Affairs Brigade is growing slowly, but is projected to be manned by Unit Status Reporting standards of 70 percent by 2016. However, the lack of manpower is not the most significant problem for the future of the civil affairs organization. Even more troubling are the growing number of unfilled U.S. Special Operations Command (USSOCOM) Civil Military Support Element missions. With the transition of Iraq back to the Iraqi government, and the future withdrawal from Afghanistan, “left of the line” or phase zero countries will become the focus of USSOCOM and the Theater Special Operations Commands (TSOCs). Currently, 11 validated Civil Military Support Elements (CMSE) missions cannot be sourced. This number will grow in fiscal year 2014 if, as anticipated, at least two of the TSOCs significantly increase their Civil Affairs demand

requirements within their region. USSOCOM Civil Affairs, the 95th Civil Affairs Brigade (A) is the only civil affairs unit with the titles, authority, and funding to execute Civil Military Engagement (CME) missions. USACAPOC and the 85th Civil Affairs Brigade currently have limited mission requirements post the Afghanistan turnover (Appendix F). The 85th is currently supporting Operation Enduring Freedom, but after fiscal year 2014, the only remaining mission requirement for that organization will be to support the training centers, as they are currently not being requested to support the future Regionally Aligned Force concept for conventional forces. In fiscal year 2014, USACAPOC will have 23 mission requirements, requiring only 389 personnel, or 13 percent of the total authorized force. In comparison, the battalion and companies subordinate to the 95th Civil Affairs Brigade (A) on average deploy 50 percent of their force and average about a 1:1 dwell-to-deployment ratio, yet still remain unable to source all USSOCOM missions. This clearly represents a misalignment of forces, which does not support the Army's required operational capacity, pointing to a need for fundamental restructuring of the Army's Civil Affairs forces.

In the following chapter, we present case studies of the Department of Defense Reorganization Act of 1986 (Goldwater-Nichols Act), the creation of the Department of Homeland Security (DHS), and the creation of United States Command Northern (NORTHCOM), in order to demonstrate the efficiencies that have been derived from the unification of organizations pursuing similar goals and facing similar difficulties.

THIS PAGE INTENTIONALLY LEFT BLANK

### III. CASE STUDIES

#### A. ORGANIZATIONAL EFFICIENCY—UNITED STATES NORTHERN COMMAND

Supposing a finding is made that the threat is not only in the Pacific where we have a unified command, or in European theater, or in the Middle East where we have a unified command, but there is reason to believe that the first target might be the United States, the homeland. On what basis can you accept the unified command concept outside of the United States and reject it in? (Johnson, 2002, p. 63)

—Senator Henry Jackson, 1958

On April 17, 2002, Secretary of Defense Donald Rumsfeld and, the Chairman of the Joint Chiefs of Staff, General Richard Meyers ushered in the 2002 Unified Command Plan (UCP) that established U.S. Northern Command (USNORTHCOM). The creation of USNORTHCOM was primarily designed to protect against the evolving threats to the United States demonstrated by the September 11 terrorists' attacks. General Richard Meyers stated, “[the UCP] takes the various homeland security missions being performed by various combatant commanders and some agencies and puts them under one commander [USNORTHCOM], and so we bring unity and focus to the mission” (U.S. Department of Defense, 2002, p. 2). USNORTHCOM would be responsible for “all air, land and sea approaches to North America, encompassing the continental U.S., Alaska, Canada, Mexico and the surrounding water areas out to approximately 500 nautical miles” (U.S. Northern Command, 2012, p. 5). In addition to the military defense of the United States, Secretary Rumsfeld stated that “[USNORTHCOM] will provide for a more coordinated military support to civil authorities, such as the FBI [Federal Bureau of Investigations], FEMA [Federal Emergency Management Agency], and state and local [governments]” (U.S. Department of Defense, 2002, p. 1). Based on organizational functions, USNORTHCOM was created and the Department of Defense (DoD) consolidated homeland defense and support to civil authority missions within one organization.

On October 1, 2002, Air Force General Ralph E. Eberhart assumed command of NORTHCOM and also retained command of the North American Aerospace Defense Command (NORAD). NORAD is the evolution of a bi-national military agreement between the Government of the United States of America and the Government of Canada for the mutual defense of North America. The primary mission of NORAD is the following: (1) “Aerospace warning for North America,” (2) “Aerospace control for North America,” and (3) “Maritime warning for North America” (North American Aerospace Defense Command, 2006, p. 2). NORAD was conceived by the United States and Canada in 1958 to “[centralize] operational control of continental air defenses against the threat of Soviet bombers” (North American Aerospace Defense Command, 2013, para. 2). In 1996, NORAD’s mission expanded to “aerospace warning and aerospace control for North America,” to include “assist[ing] civil authorities in the detection and monitoring of aircraft suspected of illegal drug trafficking” (North American Aerospace Defense Command, 2013, para. 4). In 2006, the United States and Canada added the maritime warning responsibility to NORAD’s mission (North American Aerospace Defense Command, 2013). In order for the DoD to ensure unity of effort between USNORTHCOM and NORAD without combining the organizations, the DoD appointed the USNORTHCOM commander to also serve as the NORAD commander with two deputy commanders: a Canadian general officer as the Deputy Commander for NORAD and an American general officer as the Deputy Commander for USNORTHCOM.

Based on the proposal to create USNORTHCOM, the DoD assessed other internal agencies and organizations that should be consolidated or supervised by USNORTHCOM. Joint Task Force Civil Support (JTF-CS) was previously assigned to U.S. Joint Forces Command (USJFCOM) and held the distinction of being the only standing organization that “anticipates, plans, and integrates USNORTHCOM chemical, biological, radiological and nuclear response operations” and “commands and controls designated DoD forces to assist local, state, federal and tribal partners in saving lives, preventing further injury, and providing critical support to enable community recovery” (Joint Task Force Civil Support, 2013). Joint Task Force North (JTF-N), formerly known as Joint Task Force 6, was also assigned to USJFCOM and had the primary mission of

supporting “Drug Law Enforcement Agencies in the conduct of Counter Drug/Counter Narco-Terrorism operations in the USNORTHCOM theater of operation to disrupt trans-national criminal organizations and deter their freedom of action in order to protect the homeland” (Joint Task Force North, 2013). Joint Force Headquarters National Capital Region (JFHQ-NCR), previously subordinate to USJFCOM, has the following responsibility: “land-based homeland defense, defense support of civil authorities (DSCA), and incident management in the National Capital Region [encompasses the District of Columbia and relatively small portions of Maryland and Virginia]” (Joint Force Headquarters National Capital Region, 2013). In February 2003, USNORTHCOM established the Joint Task Force Alaska (JTF-AK) charged with the “responsibility for the land and maritime defense of Alaska and consequence management” (Alaskan Command, 2011, p. 1). An agreement between USNORTHCOM and U.S. Pacific Command (USPACOM) dictates that Alaskan Command (ALCOM), a previously standing organization, will man and execute the JTF-AK mission (Alaskan Command, 2011). Currently, USNORTHCOM has four subordinate commands located around the United States to facilitate their overall mission of homeland defense and support to civil authorities.

## **1. Organizational Efficiency**

In addition to DoD’s creation of USNORTHCOM, the 2004 National Defense Authorization Act revised U.S. Code Title 32, Section 325 (32 U.S.C. § 325) which allows National Guard (Title 32) officers ordered to active duty for federal service (Title 10) to maintain their state commission. U.S. Code Title 32, Section 325 (32 U.S.C. § 325) provides the following:

TITLE 32 - NATIONAL GUARD

CHAPTER 3 - PERSONNEL

Sec. 325. Relief from National Guard duty when ordered to active duty

(a) Relief Required.

(1) Except as provided in paragraph (2), each member of the Army National Guard of the United States or the Air National Guard of the



United States who is ordered to active duty is relieved from duty in the National Guard of his State or Territory, or of Puerto Rico or the District of Columbia, as the case may be, from the effective date of his order to active duty until he is relieved from that duty.

(2) An officer of the Army National Guard of the United States or the Air National Guard of the United States is not relieved from duty in the National Guard of his State, or of the Commonwealth of Puerto Rico, Guam, or the Virgin Islands or the District of Columbia, under paragraph (1) while serving on active duty if -

(A) the President authorizes such service in both duty statuses; and

(B) the Governor of his State or Territory or Puerto Rico, or the commanding general of the District of Columbia National Guard, as the case may be, consents to such service in both duty statuses. (U.S. Northern Command, n.d., p. 13)

By the statute, the President of the United States and the respective state governor must consent to the officer serving in both Title 10 and Title 32 capacities. This hybrid command structure would facilitate unity of effort by allowing one military commander to directly command active, reserve and National Guard units for a National Special Security Event (NSSE) (anticipated) or an incident management (unanticipated), e.g., terrorist attack or natural/manmade disaster (U.S. Northern Command, n.d., pp. 14–15). Previous to amending the law, an additional and parallel command structure was required: one command structure for Title 10 (federal military forces) and another command structure for Title 32 (state National Guard/Air National Guard forces). The parallel command structure created redundancy, increased obstacles to unity of effort, and made the overall organization less efficient (Gereski & Brown, 2010, p. 73).

In order to increase unity of effort for a NSSE or an emergency, the DoD, USNORTHCOM and the National Guard Bureau (NGB) began to take additional steps to strengthen what is now called the dual-status commander. The National Defense Authorization Act for Fiscal Year 2012 recognized the position of the dual-status commander and legally defined its role within the context of a substantial disaster or emergency within the United States. In 2011, Deputy Secretary of Defense William Lynn signed Department of Defense Directive (DoDD) 5105.83 that instructed the following: (1) the establishment of 54 Joint Force Headquarters (one per state, district and territory)

to assist with federal and state missions; and (2) the charging of the National Guard Bureau with facilitating coordination among the DoD components, the newly established Joint Force Headquarters and their respective states. Also in accordance with DoDD 5105.83, each State Adjutants General must pre-designate qualified officer(s) to serve as a dual-status commander when required and authorized by the president and their respective state governor(s). In a joint venture, the NGB and USNORTHCOM provide these preselected officers the Dual-Status Commander Training Course that “prepare[s] the senior leaders on their roles as a joint force commanders in the event of large-scale disasters, such as Hurricane Sandy, or a large scale earthquake” (Baltos, 2012). Significant policy changes and specific training have facilitated an organizational efficiency that ultimately translates into increased operational effectiveness.

## **2. Training and Exercises: Building Relationships**

USNORTHCOM and the NGB have developed training that provides information to internal personnel and external personnel who may work with USNORTHCOM in the future. For external personnel, USNORTHCOM and NGB specifically developed the Dual Status Commander Training Course (initially the Joint Task Force Commanders Training Course) and began to host and present the course in 2007 in order to “[prepare] National Guard leaders and other potential joint force commanders from across the country to coordinate and integrate military and federal agencies during a disaster” (Doscher, 2010). USNORTHCOM offers the five-day training course twice a year in order to enable each state, territory and district to fulfill the requirement in DoDD 5105.83: “pre-designating commanders and staff elements within their respective States to participate in exercises and in training provided by the United States Northern Command to enhance readiness to provide command and control for domestic operations” (p. 11). For USNORTHCOM’s internal personnel, USNORTHCOM provides three different seminars concerning defense support of civil authorities based on the individual’s seniority level (Government Accountability Office, 2009, p. 63). The training provides USNORTHCOM personnel with an overview of “state emergency management structures and relevant issues related to working with civilian state and local

emergency management officials” (p. 63). The training, focused internally and externally, addresses the fundamental roles, responsibilities, and authorities for all the stakeholders of USNORTHCOM’s missions.

In addition to developing and providing tailored training, USNORTHCOM has implemented a robust exercise program in order to strengthen its ability to complete their primary missions: homeland defense and support to civil authorities. USNORTHCOM currently conducts two large-scale exercises per year: Ardent Sentry and Vigilant Shield. These two large-scale exercises include multiple agencies and organizations, multiple events and multiple sites. Within the first seven years of USNORTHCOM being established, USNORTHCOM executed 13 large-scale exercises and participated in over 30 smaller exercises (Government Accountability Office, 2009, pp. 17–27). From September 2005 to September 2009, USNORTHCOM incorporated “[s]eventeen federal agencies and organizations and 17 states and the District of Columbia,” all of which “have participated in one or more of the seven large-scale exercises that USNORTHCOM has conducted” (pp. 17–27). Although the Ardent Sentry exercise is focused on the mission of providing support to civil authorities and the Vigilant Shield exercise is focused on the mission of providing homeland defense, NORTHCOM integrates homeland defense elements within Ardent Sentry and elements of support to civil authorities within Vigilant Shield. For example, the Vigilant Shield 09 exercise included responding to an earthquake in California, and the Ardent Sentry 07 exercise encompassed the protection of critical infrastructure (p. 27). The tailored training and the robust exercise program not only provides the information and its application, but the interaction during the training and exercise allows for the creation of social capital defined by Don Cohen and Larry Prusak (2001) in *In Good Company* as “the stock of active connections among people; the trust, mutual understanding, and shared values and behaviors that bind the members of human networks and communities and make cooperative action possible” (p. 4).

### **3. Dual-Status Command in Action—Republican National Convention**

Based on the 2004 Republican National Convention—Capabilities Identification and Generation case study within the Domestic JTF [Joint Task Force] Commander Handbook (U.S. Northern Command, n.d., pp. 282–285), the following events occurred. The 2004 Republican National Convention, a designated NSSE, in New York City was an early instance in which a dual-status commander was designated. President Bush and New York Governor George Pataki appointed Brigadier General David Sheppard (a New York National Guard member) as the dual-status commander for operational security of the event. After General Sheppard and his staff conducted a thorough mission analysis and consulted with organizations contributing to the mission, they were able to identify capabilities gaps that were required in order to properly secure the convention. Sheppard's Joint Task Force presented one set of requirements to The Adjutant General (TAG) of New York, and he distributed the requirements among the New York National Guard, the New York Air National Guard, the New York Militia and the New York Navy Militia. Upon expending New York's internal military resources, General Sheppard's requirements were resourced higher at the NGB. The NGB specifically directed that two Civil Support Teams, one from Massachusetts and one from Pennsylvania, be apportioned to the JTF for the duration of the event. General Sheppard sent the remaining requirements that were unsupportable by the state or the NGB to USNORTHCOM for resourcing. The primary capability that General Sheppard required was the ability to communicate (to include connectivity, high-rates of bandwidth and coverage) with the numerous stakeholders involved with the event. In order to fill this critical requirement, USNORTHCOM provided the Joint Task Force with a Joint Task Force Commander's Communication Package and an active duty communications team from the Army's Communications and Electronics Command to properly employ the communications equipment. Joint Task Force-New York successfully secured the convention, and the dual-status command concept was instrumental for the mission.

#### **4. Waldo Canyon Fire–Colorado**

On June 22, 2012, the Mantiou Springs Fire Department in central Colorado received reports of smoke in the vicinity of Waldo Canyon. Although first responders were actively searching for the source of the smoke, they were unable to find the origin by nightfall and restarted their search the next morning at 0700. At noon on June 23, multiple residents from the Pikes Peak Region reported smoke coming from Waldo Canyon. At approximately the same time the reports were being made, the first responders confirmed a quick-burning fire within the Pike National Forest. As initial firefighting activities were conducted, the local government activated the Colorado Springs Emergency Operations Center (CSEOC), and they began managing the incident, to include firefighting operations and evacuations (mandatory and voluntary). During the day of June 24, the fire quickly spread northwest and south due to high temperatures and erratic wind. Later in the evening, the Type 1 Incident Management Team arrived and began managing the fire. On June 25, government officials estimated that the Waldo Canyon Fire included approximately 4,500 acres (City of Colorado Springs, 2012, p. 9). On the next day, a thunderstorm produced extreme wind conditions that directly contributed to the growth of the fire from 4,500 acres to over 15,000 acres. Based on the significant increase of the fire, Secretary of Defense Leon Panetta and Colorado Governor John Hickenlooper appointed Colonel Peter Byrne (the Colorado National Guard's Joint Task Force-Centennial commander) as the Dual-Status Commander for military support to the Incident Commander on June 27. Colonel Byrne was able to command and control the following federal and state military resources: multiple C-130 aircrafts with Service Modular Airborne Fire Fighting Systems, 10 bulldozers, 120 soldiers and other miscellaneous equipment and resources (U.S. Northern Command's Public Affairs Office, 2012). As firefighting efforts increased and favorable weather conditions occurred, the containment percentage of the fire steadily increased over the next few days. COL Byrne was released from dual-status command authority on July 6, 2012 and returned to commanding Joint Task Force Centennial (Colorado National Guard). Although the Waldo Canyon fire was fully contained on July 10, 2012, it had destroyed approximately 345 homes and over 18,000 acres, becoming the most

destructive wildfire in Colorado history (City of Colorado Springs, 2013, p. 5). The dual-status commander and the military resources that he employed directly contributed to containing the fire and limiting further devastation of the wildfire.

## **5. Conclusion**

With the creation of USNORTHCOM, the DoD has established a single organization responsible for homeland defense and military support to civil authorities. In collaboration with other agencies and organizations, USNORTHCOM has created specific training for senior leaders that enables them to command military resources when required for anticipated or unanticipated events. USNORTHCOM has also generated a vigorous exercise program that provides benefit not only to USNORTHCOM, but also to the other stakeholders of homeland defense and support to civil authorities. The coupling of training and exercises is the foundation for creating relationships and trust among organizations and individuals tasked to successfully accomplish complex missions. By championing and supporting the dual-status commander, USNORTHCOM internalized greater levels of organizational efficiency and increased its operational effectiveness. This experience with USNORTHCOM thus demonstrates the significance of organizational efficiency and the organizational gains that can be achieved through a more unified command structure.

## **B. TRAINING EFFICIENCY—CREATION OF THE DEPARTMENT OF HOMELAND SECURITY**

We recommend significant changes in the organization of the government. We know that the quality of the people is more important than the quality of the wiring diagrams. Some of the saddest aspects of the 9/11 story are the outstanding efforts of so many individual officials straining, often without success, against the boundaries of the possible. Good people can overcome bad structure. They should not have to. (National Commission on Terrorist Attacks upon the United States, 2004, p. 399)

The U.S. government officially established the U.S. Department of Homeland Security (DHS) with the passing of the Homeland Security Act of 2002 on November 25, 2002. In the direct aftermath of the September 11, 2001, terrorist attacks, President George W. Bush appointed Pennsylvania Governor Tom Ridge as the Director of the

Office of Homeland Security on September 22, 2001. From within the White House, Governor Ridge was responsible for supervising and coordinating “a comprehensive strategy to safeguard the country against terrorism and respond to any future attacks” (U.S. Department of Homeland Security, 2013, para. 2). In June 2002, President Bush officially proposed the creation of the DHS with the singular mission of protecting the homeland. Upon the approval of the Homeland Security Act of 2002, the DHS became an Executive Department with the following seven tasks:

(A) prevent terrorist attacks within the United States; (B) reduce the vulnerability of the United States to terrorism; (C) minimize the damage, and assist in the recovery, from terrorist attacks that do occur within the United States; (D) carry out all functions of entities transferred to the Department, including by acting as a focal point regarding natural and manmade crises and emergency planning; (E) ensure that the functions of the agencies and subdivisions within the Department that are not related directly to securing the homeland are not diminished or neglected except by a specific explicit Act of Congress; (F) ensure that the overall economic security of the United States is not diminished by efforts, activities, and programs aimed at securing the homeland; and (G) monitor connections between illegal drug trafficking and terrorism, coordinate efforts to sever such connections, and otherwise contribute to efforts to interdict illegal drug trafficking. (Homeland Security Act of 2002, 2002, p. 2142)

The DHS, the newest cabinet-level department, became operational on March 1, 2002, a mere five months after September 11, 2001. The Homeland Security Act of 2002 effectively unified 22 federal agencies and departments, all or in part, under the DHS to focus on securing the homeland (U.S. Department of Homeland Security, 2013). Prior to the reorganization, responsibilities for protecting the homeland were disseminated across the following agencies or departments: Department of Treasury, Department of Justice, Department of Energy, Department of Transportation, Department of Agriculture, Federal Bureau of Investigations, Department of Defense, General Services Administration, Federal Protective Service, Federal Emergency Management Agency, Health and Human Services, U.S. Coast Guard and U.S. Secret Service (U.S. Department of Homeland Security, 2013). In addition, and primarily based on function, organizations within other agencies and departments were reassigned to the DHS in order to fulfill the overall mandate of protecting the homeland. For instance, the U.S. Customs and Border

Protection and the U.S. Immigration and Customs Enforcement divisions were components of the Department of Treasury prior to the reorganization and are now a part of the DHS (U.S. Department of Homeland Security, 2013). Within the Department of Energy, the Nuclear Incident Response Team; the Chemical, Biological, Radiological, and Nuclear (CBRN) Countermeasures Programs; the Environmental Measurements Laboratory; and the Energy Security and Assurance Program were apportioned to DHS based on their specific missions and capabilities.

Along with other agencies and departments consolidated within the DHS, the Federal Law Enforcement Training Center (FLETC) headquartered in Glynco, Georgia, was also placed under the control of the DHS in accordance with the Homeland Security Act of 2002. As the premier interagency law enforcement training organization, FLETC provides basic and advanced law enforcement training to 91 federal agencies at residential and non-residential training sites (Federal Law Enforcement Training Center, 2013). During the 2012 fiscal year, FLETC trained a total of 69,587 law enforcement officers and agents through residential and on-line training programs (Federal Law Enforcement Training Center, 2012). This training is conducted by law enforcement professionals with approximately 50 percent of the trainers being permanent instructors and the other 50 percent consisting of either interagency personnel on a short-term basis or recently retired agents from the field (Federal Law Enforcement Training Center, 2013). The FLETC model of having permanent instructors, short-term instructors and recently retired agents from the field conducting the training has two major benefits, (1) instructors with current operational experiences constantly challenge the curriculum and (2) students are building relationships with other students within other organizations. Under the establishment of the DHS, FLETC has significantly improved its ability to accomplish the task of training the protectors of the homeland.

### **1. Flexible and Fast Training Response**

In line with President Bush's June 2002 proposal for the Department of Homeland Security, the FLETC began to plan and prepare for the increasing demand signal that was on the horizon. Prior to 2002, the FLETC organization was graduating approximately



24,000 students per year (Federal Law Enforcement Training Center, 2005). In 2002, FLETC was able to increase training output by 24.9 percent and successfully trained 32,092 students for the year (Federal Law Enforcement Training Center, 2003). In 2003, FLETC continued to increase training by 3.5 percent and successfully trained 33,219 students (Federal Law Enforcement Training Center, 2003). Of those students who graduated, 46 percent were assigned to agencies and organizations directly within the DHS: U.S. Customs and Border Protection, U.S. Immigration and Customs Enforcement, U.S. Customs and Border Protection, U.S. Immigration and Customs Enforcement, U.S. Citizenship and Immigration Services and the Transportation Security Administration (Federal Law Enforcement Training Center, 2003). Although the FLETC was able to accommodate the 29 percent growth in training demand within a three-year period, the FLETC was also prepared to do more.

After being transferred to the DHS on March 1, 2003, in conjunction with the new emphasis on deterring and defeating terrorism, the FLETC training became operationally focused and even more tailored to meet the needs of their customers. The FLETC's Security Specialties Division (SSD) developed two significant courses with regard to the evolving threats of the day: Suicide/Homicide Bomber Awareness and Introduction to Man Portable Air Defense System (MANPADS) (Federal Law Enforcement Training Center, 2003). The Suicide/Homicide Bomber Awareness course was developed in concert with the Israeli Security Agency, and the Introduction to MANPADS course was developed with the assistance of the Department of Defense and other interagency partners (Federal Law Enforcement Training Center, 2003). The FLETC was also responsible for developing the first armed pilot training program, officially known as the Federal Flight Deck Officer (FFDO) program, in order to deter and prevent unauthorized control of commercial airliners (Federal Law Enforcement Training Center, 2003). This training is currently supported with realistic environments to include three 727 aircraft, three live-fire shoot houses configured as aircraft, and two mat rooms with cockpit seats to conduct defensive tactics training in confined spaces (Federal Law Enforcement Training Center, 2003). In addition to the courses above, the FLETC's Financial Fraud Institute (FFI) developed training applications specifically for the war on terrorism: the

Internet Investigations Training Program for investigating the compromise of secure data, and the Intelligence Analyst Training Program for entry level local, state and federal law enforcement personnel (Federal Law Enforcement Training Center, 2003). During this time, the FFI continued to develop the Internet Forensics Training Program in order to investigate computer hacking and cyber-terrorism (Federal Law Enforcement Training Center, 2003). Within the preliminary stages of the war on terrorism, FLETC remains flexible and responsive to the operational needs of the DHS.

The FLETC training is tailored for its partnered organizations, and the FLETC attempts to provide what the partnered organizations require for their specific organizational mission. For example, the Artesia Training Division located in New Mexico provides all training required to become a U.S. Border Patrol Agent. The Border Patrol Academy is a 58-day resident course that provides instruction pertaining to integrated law, physical training, firearms instruction, and drivers training (U.S. Customs and Border Patrol, 2013). For those individuals who do fulfill the Spanish language requirement, an additional 40 days of Spanish instruction is provided to prospective agents (U.S. Customs and Border Patrol, 2013). Upon successful completion of the academy and attaining the Spanish language skill, the newly trained Border Patrol Agent is assigned to one of the U.S. Border Patrol Sectors. Unlike the Border Patrol Agent training path, the U.S. Secret Service relies upon the FLETC to provide their personnel, agents and uniform division personnel, a basic law enforcement foundation. Upon completion of the program at FLETC, the Secret Service personnel conduct agency specific and advanced training at the Secret Service training facility: James J. Rowley Training Center. The Rowley Training Center provides advanced training specific to the Secret Service mission and duties in the following areas: “protective, investigative, specialized tactical and executive/managerial training” (U.S. Secret Service, 2013, para. 1). The FLETC’s ability to be flexible and provide customers with what they require is key to retaining relevancy in financially austere environments.

## **2. Cost Avoidance and Operational Efficiencies**

In a period of reduced funding, the FLETC has attempted to further efficiencies throughout their operations and facilities. The FLETC's Protocol and Communications Office has been able to advocate for providing event management services to include conferencing, dormitories and cafeteria facilities to outside agencies. In fiscal year 2012, the Protocol and Communications Office was responsible for managing three significant conferences by the U.S. Immigration and Customs Enforcement agency, the U.S. Secret Service and the Federal Emergency Management Agency (Federal Law Enforcement Training Center, 2012). By using internal facilities organic to the FLETC, the DHS was able to avoid \$1.2 million in cost that would have been realized by using the private marketplace for these conferences (Federal Law Enforcement Training Center, 2012). In addition to larger conferences taking place at the FLETC facilities in Glynco, Georgia, the FLETC has hosted smaller events like the annual board meeting for the Federal Law Enforcement Training Accreditation process and the DHS Office of General Counsel Homeland Security Law Conferences at Charleston, South Carolina and Glynco sites. Again, the DHS was able to save approximately \$48,000 by utilizing FLETC facilities instead of contracting for hotel and conference accommodations in the private sector (Federal Law Enforcement Training Center, 2012). In addition to maximizing facilities internally, the FLETC has been able to leverage governmental partners (rural, local, state and territorial law enforcement agencies) for the use of training areas and other facilities for mobile training courses. With regard to facilities, the FLETC is attempting to maximize the use of their facilities for the benefit of the DHS and capitalize on partner resources to reduce overall costs for their customers.

The FLETC is also attempting to increase efficiencies with the incorporation of technology in the day-to-day training operations. Within a training or educational environment, significant cost is associated with printed material for the students. The FLETC has piloted a program to implement the use of electronic tablets in order to reduce the cost associated with traditional law enforcement textbooks (Federal Law Enforcement Training Center, 2012). In addition to increasing the access and ease to the material for students, the FLETC was able to decrease their printing costs and gain

additional classroom space previously used for book storage (Federal Law Enforcement Training Center, 2012). Based on an internal review, the FLETC implemented changes with the creation of the Centralized Training Management Directorate (CTMD) “to consolidate processes and procedures associated with law enforcement training management into one enterprise-focused directorate” (Federal Law Enforcement Training Center, 2012, p. 38). The CTMD provides the following: (1) maximizes geographically dispersed training facilities and resources, (2) minimizes the duplication of effort concerning training development and delivery, and (3) expands the ability to quickly respond to emerging trends across the law enforcement spectrum (Federal Law Enforcement Training Center, 2012). At the Charleston, South Carolina, site, the FLETC has constructed a virtual firearms range that will considerably reduce the amount of money required for ammunition (Federal Law Enforcement Training Center, 2012). These technology-based innovations have assisted the FLETC in reducing operational costs and providing a better service.

The FLETC has also reviewed their logistical requirements and procurement processes with the goal of avoiding unnecessary purchases. In fiscal year 2012, the U.S. Customs and Border Protection agency held a number of excess vehicles with low mileages, and the FLETC coordinated for 78 of those vehicles to replace many of the FLETC’s current vehicles that had exceeded their life expectancy (Federal Law Enforcement Training Center, 2012). The cost savings associated with this transfer of property will reach approximately \$3 million over the next 3–5 years (Federal Law Enforcement Training Center, 2012). During the same time frame, the U.S. Capital Police, a partnered organization, donated six previously used armored Chevrolet Suburbans for the FLETC’s fleet of training vehicles (Federal Law Enforcement Training Center, 2012). As well as being a cost savings for the FLETC, the armored vehicles provide specialty training to numerous law enforcement students and multiple agencies (Federal Law Enforcement Training Center, 2012). With the relative high cost of maintaining vehicles, the FLETC has also been able to eliminate 45 vehicles from their enterprise-wide fleet by incorporating a methodology for vehicle allocations that increases overall vehicle use effectiveness (Federal Law Enforcement Training Center,

2012). In addition to vehicles, the FLETC has been able to transfer over 9,379 items of real property valued at \$580,354 to other agencies within the U.S. government and has been able to procure 219 items worth \$955,301 from other federal agencies (Federal Law Enforcement Training Center, 2012). The FLETC has also implemented environmental cost saving measures, such as installing light-emitting diode (LED) lighting technology and replacing an archaic steam distribution system with natural gas-fired boilers. These combined upgrades have contributed to the following: decreased fuel oil consumption by 75 percent, decreased natural gas consumption by 50 percent during the summer months and reduced water consumption by one million gallons annually (Federal Law Enforcement Training Center, 2012). Not only is the FLETC able to assess and implement internal cost savings, the FLETC has the ability to leverage their partnered organizations and other DHS agencies for resources that ultimately reduces the FLETC's operating costs.

The consolidation of agencies with the primary mission of securing the homeland under the DHS has contributed to training and organizational efficiencies. The FLETC has demonstrated responsiveness to emerging operational requirements by developing and providing new training, as well as the ability to increase or decrease the training of law enforcement agents for DHS agencies and partnered organizations. Other divisions and agencies within the DHS provide the FLETC with personnel and resources that would have been unattainable without the unification. Moreover, the interagency culture that is present within the FLETC provides a natural environment for students to learn about other organizations and how they contribute holistically to protecting the homeland. The DHS, executed through FLETC, thus shows the importance of training efficiency and the organizational improvements that can be attained through a more centralized organizational structure.

**C. OPERATIONAL EFFICIENCY—THE DEPARTMENT OF DEFENSE REORGANIZATION ACT OF 1986 (GOLDWATER–NICHOLS ACT)**

The system is broken. I have tried to reform it from inside, but I cannot. Congress is going to have to mandate necessary reforms.

—General David Jones  
Chairman Joint Chiefs of Staff, 1982  
(Feickert, 2012)

The reorganization of the military to improve operational effectiveness has been an evolving process. After witnessing the friction between the Army and Navy in the Pacific during World War II, President Truman noted, “We must never fight another war the way that we fought the last two. I have the feeling that if the Army and Navy had fought our enemies as hard as they fought each other, the war would have ended much earlier” (Feickert, 2012, p. 10). President Truman strove to achieve a more joint military approach by signing the National Security Act of 1947. The act reorganized the military by establishing seven regional commands and creating both the Air Force, and the Joint Chiefs of Staff, as well as establishing seven regional commands and the office of the Secretary of Defense. All of these adjustments were made to reduce inter-service friction, clearly define regional responsibilities, and require all regional commands and Services to answer to the Secretary of Defense.

In 1958, after his experience as the Supreme Allied Commander, President Eisenhower decided to mandate a more unified and efficient chain of command to deploy military forces as needed. President Eisenhower wanted “a complete unification of all military planning and combat forces and commands” (Feickert, 2012, p. 4). The intent was to end separate land, sea, and air combat. To accomplish this, the president proposed the Department of Defense (DoD) Reorganization Act of 1958 to amend the National Security Act of 1947. The act established a “clear line of command from the President, through the Secretary of Defense, to the combatant commanders” (p. 12). The regional combatant commanders obtained operational control over the forces assigned to them during combat operations.

Even with these two attempts to force a unified and joint military approach, inter-service competition for resources continued. Before reorganization was considered, the

Services' preference was to retain the status quo. "Like other government organizations, each Service vied for increased autonomy; each wanted to protect its budgets and expand its role" (Besson, 1998, p. 10). However, in response to several poorly executed and failed military missions during the 1960s through the 1980s, the perception of some in Congress was that the United States had not won a war in twenty years. The perceived cause of the mission failures was the absence of a unified command structure, the intensity of inter-service competition, and the lack of interoperability between the Navy, Marines, Army, and Air Force. After the failed Iranian rescue mission and the bombing of the Marine barracks in Beirut highlighted what can happen operationally without unity of command and interoperability, the Goldwater-Nichols Act of 1986 (GNA) reorganized the DoD into a joint team under a unified command to improve operational efficiency and effectiveness for future U.S. military operations.

### **1. Failed Iranian Rescue**

On April 24, 1980, the United States attempted a raid to rescue sixty-six American citizens who were being held hostage in the U.S. embassy in Tehran. The military had six months to plan, organize, and train for the raid. However, inter-service competition made the raid more complex than it needed to be. Each service wanted to be involved in the operation and the Pentagon did what they could to appease each service. Unfortunately, service rivalry and organizational pride affected operational success. A joint task force commander was selected, but the commander did not have any experience working with the other services. Even if the commander had that experience, the culture of the military was not conducive to joint collaboration or unity of effort. This culture led to separate planning and planning secrecy. To make matters worse, no joint rehearsals were conducted. The first time the soldiers within the task force saw each other was on the ground in Iran at Desert One. This planning in isolation and lack of joint training confused the command and control structure on the ground. "Colonel James Kyle, U.S. Air Force, who was the senior commander at Desert One, would recall that there were four commanders at the scene without visible identification, incompatible radios and no agreed upon plan" (Locher, 2001, p. 6). The years of competition for fiscal resources to support the nation's security strategy resulted in a lack of interoperable vital systems

among the services, with the individual services receiving funding at the expense of the weaker, underrepresented unified commands. These inter-service power struggles can thus be tied directly to the raid's failure.

## **2. Marine Barracks Bombing**

In 1983, the Beirut Marine barracks were truck-bombed by terrorists killing 241 U.S. Marines and 50 French soldiers. The convoluted chain of command was deemed to be the core weakness that impeded proper security measures for the Marines and led to the security failure in Beirut (Besson, 1998, p. 18). The inability to make adjustments to the security posture in order to protect the soldiers was also a problem. Because of the confusing command structure, it was difficult to ascertain who was responsible for the failure in security. The Marine detachment commander in Beirut reported to the Commander Sixth Fleet, to European Command (EUCOM), and to the Supreme Allied Commander Europe (SACEUR). However, none of those senior commanders were involved with the day-to-day operations of the Marine detachment. The Marine detachment received most of its support and direction from the Marine Corps, but the Marine Corps Commandant stated that “the Marine Corps was responsible only for organizing, training, and equipping its forces and not the day-to-day operational command of forces in Lebanon” (p. 18). With unclear lines of responsibility, President Reagan assumed full responsibility for the operational failure.

## **3. GNA Objectives**

The purpose of the GNA was to balance the relationships and interests among the regional combatant commands and individual services. To strike a balance and create a more capable military, the GNA sought to provide for more efficient use of defense resources, while also enhancing the effectiveness of military operations and improving the management and administration of the DoD. In the following sections, we seek to evaluate the effectiveness of the GNA, by examining U.S. military operations in the Gulf War and Somalia, all of which occurred in the post-GNA era.



#### **4. Gulf War**

Although Operation Just Cause was the first operation post-GNA, Operations Desert Shield and Desert Storm provided a greater test for the effectiveness of the act. In August 1990, Iraq invaded Kuwait to obtain Kuwait's vast oil resources. The invasion was not anticipated and surprised the majority of the international community. Together the element of surprise and the invasion's purpose quickly united western and Arab countries against Iraq's operation and its president, Saddam Hussein.

To support Operation Desert Shield, the military rapidly positioned Navy carrier battle groups, deployed Army forces, and positioned Air Force fighter and surveillance platforms to halt the advancing Iraqi invasion. This shaping operation allowed the increase of forces needed to switch from defensive operations to offensive operations and expel all Iraqi forces and liberate Kuwait. The build up of forces and material took five months and was the largest military commitment since the Vietnam War.

Desert Storm began in January and was led by a massive air campaign that lasted for approximately five weeks. Navy and Air Force assets targeted Iraqi anti-aircraft platforms and key communication and electrical grids. The air campaign set the conditions for the Army and Marine 100-hour ground campaign that successfully defeated the Iraqi force and achieved the U.S. policy objectives.

The operations were successful and the GNA assisted in facilitating that success. The unification of operational command with the commander-in-chief (CINC), General Schwarzkopf, ensured unity of effort and synchronized mutually supporting operations. The Marines wanted to conduct an amphibious assault on Kuwait through heavily mined waters. General Schwarzkopf denied the request, but the Marine commandant attempted to bypass him and obtain approval from the Chairman Joint Chiefs of Staff (CJCS). Prior to the GNA, the Service chief would have normally have received permission from the CJCS. The CJCS followed the GNA and supported General Schwarzkopf's decision. This kept the command authority with the CINC and diminished the Service chief's role in operations.

In order for the operations to be successful, all of the logistics needed to arrive quickly and efficiently. The GNA established a single joint transportation command that was responsible for “moving 500,000 troops and 6 million tons of equipment from the United States and Europe into the theater of operations” (Besson, 1998, p. 32). Lieutenant General Pagonis was the commander of the transportation command and “unequivocally credited GNA reforms with letting him get the job done” (p. 32).

## **5. Somalia**

Soon after Desert Storm, Operation Restore Hope provided another opportunity to measure the success of the GNA in a different environment. This operation was not a war, but was defined as an operation other than war (OOTW). OOTW's can be more challenging and complex because of multinational military and civilian organization involvement.

In late 1991, fighting between the two main Somali clans had intensified. By February 1992, over 30,000 people had been killed and one million people were displaced from Somalia to neighboring countries. Some international aid was provided, but had little success in reducing the fighting, famine, and disease. The conditions continued to decline, and by late 1992, the government collapsed. President George H. W. Bush was compelled by public opinion to involve the United States in Somalia. The United Nations authorized a U.S.-led, 30 nation Unified Task Force (UNITAF) consisting of 16,000 U.S. soldiers and 16,000 soldiers from the other supporting countries. The mission to stop the clan fighting and protect the humanitarian assistance efforts was successful. By 1993, the clan fighting had been stopped, famine and disease rates were decreasing, and markets and schools were reopened. The United States transitioned the mission over to the U.N. and redeployed the majority of their personnel and equipment. Unfortunately, the success was short lived. The U.N. did not have enough forces or the proper equipment to patrol Mogadishu and maintain security. This provided an opportunity for Mohammed Farah Aideed, a clan leader, to return to Somalia. In June 1993, a group of Aideed supporters ambushed a U.N. patrol and killed 24 Pakistani

soldiers. The U.N. Security Council sought retribution and determined that Aideed was to be arrested and his command center destroyed. The U.S. raid to capture Aideed was unsuccessful, and in the attempt, 18 U.S. soldiers were killed.

Although Aideed was not captured, the GNA reorganization was successful with regards to the initial deployment and command structure. Somalia had zero infrastructure for the United Nations (UN) forces to utilize. There was no water, electricity, food, or government. The United States had to deploy their forces with everything needed to sustain them for the operation. The GNA, as in the Gulf War, facilitated the achievement of rapidly projecting U.S. military power. The new DoD organization displayed the flexibility to deploy a large force quickly for an untraditional operation in an extremely austere environment. Another GNA success was the unified command structure. All the forces were responsible to a single unified command. This ensured unity of effort of all 30 contributing countries and avoided further complexity in an already complex and dynamic environment. The command structure provided by the GNA was instrumental in the UNITAF's operational effectiveness.

## **6. Conclusion**

The GNA has not solved all the inter-service problems that existed prior to the reorganization. Some issues still remain within the Department of Defense. The GNA was adopted in 1986, and the United States has been at war for the past decade. An update of the GNA might be necessary based on the most recent lessons learned. However, the operational successes after the GNA reorganization show how effective it was in promoting unity of effort during military operations. The GNA reduced the amount of inter-service fighting and eliminated non-mutually supporting military operations. General Colin Powell stated, "Performance of the Armed Forces in joint operations has improved significantly and Goldwater-Nichols deserves a great deal of the credit" (Locher, 2001, p. 17). The GNA's reorganization of the Department of Defense thus demonstrates the value of operational efficiency and the organizational advances that can be accomplished through a consolidated command structure.

## **IV. CURRENT CIVIL AFFAIRS REORGANIZATION PROPOSALS**

In this chapter, we consider several proposals from U.S. Army Special Operations Command, U.S. Army Civil Affairs and Psychological Operations Command, and the Department of the Army on how Civil Affairs should be structured within the Army. The proposals all suggest that a change to the current structure is required, but differ when it comes to how many Civil Affairs headquarters should exist and how large the organizations should be. We will examine each in turn, applying our criteria of organizational efficiency, training efficiency, and operational efficiency in order to determine strengths and weaknesses of each proposal.

### **A. PROPOSAL #1–ACTIVE DUTY CONSOLIDATION**

The active duty consolidation proposal (Appendix J) combines both active duty Civil Affairs brigades and positions them subordinate to an active duty brigadier general headquarters. The headquarters would be built from reinvestments of positions from the 95th and 85th brigade headquarters. The brigadier general command billet, the deputy commanding general colonel position, and primary staff officer positions would require “bill payers” from the Army to create those positions. The 85th Civil Affairs Brigade would be coded as a special operations force in order for the brigade to be able to conduct Civil Military Engagement (CME) missions. By recoding the 85th Civil Affairs Brigade to Special Operations Forces (SOF), all of the 11 validated unmanned CME mission requirements would be sourced. The entire reserve force would remain unchanged, and the reserves would have the primary mandate to support conventional forces and possibly the Civil Affairs global response force company. This force design provides the best operational result for U.S. Special Operations Command (USSOCOM) while still providing support to the conventional force with reserve Civil Affairs units.

However, this proposal is not optimal for organizational efficiency or operational efficiency. Organizationally, this proposal reduces, from three to two, the number of commands to which Civil Affairs is subordinate. Although this is an improvement, two

competing organizations remain. It also further divides the force between the active and reserve components and therefore cannot achieve full unity of command. There would also be operational impacts if this proposal were implemented. U.S. Forces Command (USFORSCOM) would lose their only direct reporting civil affairs capability, and their ability to directly allocate one civil affairs company for the Global Response Force (GRF). To source the GRF company, U.S. Army Special Operations Command (USASOC) would have to agree to use the companies from the 95th and 85th, making any future CME mission expansion far more difficult to source.

## **B. PROPOSAL #2–TITLE 10 COMMAND CONSOLIDATION**

The Title 10 command consolidation proposal also falls short of being an optimal organizational structure. This proposal consolidates the three separate Civil Affairs commands into one command subordinate to the U.S. Army Special Operations Command (USASOC). However, it still leaves two smaller Civil Affairs units outside the proposed organization. As a result, while this proposal promises some of the advantages of unification seen within the U.S. Northern Command (USNORTHCOM) case study, it fails to incorporate organizational efficiencies observed in the Department of Homeland Security (DHS) and the Goldwater-Nichols Act (GNA) case studies. Essentially, the proposal fails to adequately address the structural deficiencies within the organization.

In the USNORTHCOM and DHS case studies, we observed that the U.S. government consolidated all of the functional organizations that had a role to play in the homeland security mission. In contrast, this proposal only consolidates U.S. Army Civil Affairs and Psychological Operations Command (USACAPOC), the 95th and the 85th Civil Affairs units within USASOC, and fails to incorporate the 361st and the 322nd Civil Affairs Brigades that are located at Hawaii and in Germany. As a result, redundancy between the CACOMs and the separate brigades would continue to exist, and in addition to these redundant capabilities, the 361st and the 322nd Civil Affairs Brigades would continue to rely primarily upon personnel from USACAPOC to fill their positions. This proposal would thus be similar to the DHS not incorporating the U.S. Coast Guard into

its new organizational structures. Although some efficiency would be gained through consolidating some of the organizations, the proposal still maintains duplication of effort and the inefficient use of resources.

The Title 10 command consolidation proposal also perpetuates existing training inefficiencies. In the DHS case study, we saw how the Federal Law Enforcement Training Center (FLETC) has allowed DHS to forego each agency having separate training facilities and programs to decrease the cost of training for the overall organization. If a graduate of the FLETC is not returning to a specific position within the DHS, the outside organization compensates FLETC for the training based on a memorandum of understanding. In contrast, this proposal continues to allow reserve personnel to attend a Civil Affairs qualification course and return to a non-Civil Affairs position. This practice not only wastes resources within the training organizations, but it also wastes personnel resources from USASOC's operational units that are mandated to facilitate training.

Despite these shortcomings, this proposal nevertheless would provide an opportunity for most of the Civil Affairs force to be centrally controlled, allowing commanders to better manage the deployment of Civil Affairs forces. Especially within the Theater Special Operations Commands (TSOC), Civil Affairs forces would now be better able to conduct joint operations with Navy and Marine Special Operations Forces. In addition to providing Civil Affairs assets to the TSOCs, the unified command would provide Civil Affairs assets to USFORSCOM units deploying in support of Geographic Combatant Commanders (GCC). Thus, although the organization would continue to face specific shortages of key personnel, we conclude that this proposal would far outperform the active duty consolidation proposal.

### **C. PROPOSAL #3—ELIMINATION OF THE 85TH CIVIL AFFAIRS BRIGADE**

The Department of the Army's proposal to eliminate the 85th Civil Affairs Brigade (Appendix L) poses similar problems to those encountered within Proposals One and Two. The Civil Affairs organization would continue to be fractured, in violation of

Fayol's principle of unity of command. The elimination of the 85th Civil Affairs Brigade and the reorganizing of the Civil Affairs force afterwards present two possible scenarios. First, the 85th could be disbanded (depicted in Appendix M), in which case the 95th would remain the only Civil Affairs force subordinate to an active duty headquarters. Second, there could be a complete unification, similar to Proposal Two, which would unify the active and reserve civil affairs forces subordinate to USASOC, minus the 85th. In either scenario, the reserve force would remain unchanged and the 95th would become the only active duty Civil Affairs force. The reserves would have the primary mandate to support conventional forces, including the Civil Affairs global response force company.

The elimination of the 85th would have serious organizational and operational impacts. Losing a brigade worth of senior officer and enlisted billets would severely degrade career progression opportunities, and would impact future promotions of the current force. The enlisted promotions had been increasing due to the new positions that have been being created by the forming battalions in the 85th. If the 85th is eliminated, the promotions from Sergeant First Class to Master Sergeant and Master Sergeant to Sergeant Major would be significantly reduced because of a lack of senior enlisted positions in a single active brigade configuration.

Operationally, if the 85th were eliminated, roughly 45 active and reserve brigades would be without support from a civil affairs company during full surge conditions. On paper USACAPOC could support the conventional forces, but given their critical shortage of personnel in the ranks of Sergeant to Sergeant First Class and Captain to Major, they do not possess the necessary tactical Civil Affairs companies to answer the demand. Also, due to the mobilization process, the reserves would not be able to source the GRF civil affairs company. The reserves are not designed to be a quick reaction force and are required by policy to go through an in-depth soldier readiness process and unit training before being deployed.

Moreover, continuing to have two competing units can lead to disaster and confusion, as we saw in our examinations of the operations in Tehran and Beirut. During both episodes, multiple special operation forces were competing to be involved in the mission instead of determining what capability would be best suited for the mission.

During the operation, no one knew who was in charge of the entire operation, and the result was a failed mission. This proposal maintains a similar competition for missions and resources among the active and reserve Civil Affairs forces, which can only further complicate the question of who is in charge of Civil Affairs. Under such circumstances, it seems likely that each organization will continue to compete for the same missions and resources in an attempt to protect and promote their organization's interests, dividing operational efforts where they should be unified across organizations, and duplicating efforts in manning and training that could be productively divided between organizations. Consequently, we conclude that this proposal would be the least likely of those considered thus far to produce our desired improvements in organizational, training, and operational efficiency.



THIS PAGE INTENTIONALLY LEFT BLANK

## V. RECOMMENDATION

### A. DESCRIPTION

We propose that the optimal force solution to maximize organizational, training, and operational efficiencies would be a unified multi-component command (Appendix M). Although similar to proposal two, “Complete Consolidation,” there are several key differences in our approach. First, the newly created Civil Affairs Special Operations Command (CASOC) headquarters and each reserve brigade and battalion headquarters would be multi-component. Second, the four Civil Affairs Commands (CACOM) would be condensed into five multi-component Army Service Component Command planning staffs. Third, because of the reduction of the CACOMs, the functional specialty cells that resided within the CACOMs would be realigned and consolidated at each brigade headquarters. Finally, four reserve brigades would be disbanded to reduce duplication of effort and improve the overall reserve unit manning strength. The resulting reserve forces would consist of five brigades with five battalions each and three companies per battalion for a total of 75 line companies.

The CASOC (Appendix N) would be organized similarly to the U.S. Army Special Forces Command (USASFC). The headquarters would be built from the headquarters of U.S. Army Civil Affairs and Psychological Operations Command (USACAPOC), the four USACAPOC CACOMs, and the brigade headquarters of the 95th and 85th Civil Affairs Brigades. The CASOC headquarters and primary staff officers would require Army bill payers to create those new positions. The organization of the CASOC would facilitate staff actions to and from U.S. Army Special Operations Command (USASOC), alleviating the requirement to have a single staff section responsible for two or more staff functions. Also making the CASOC headquarters and the reserve brigade and battalion headquarters multi-component ensures synchronization and support for all of the reserve units during the entire Army Force Generation Cycle (ARFORGEN).

The Army Service Component Commands (ASCC) staffs (Appendix O) would be built from the CACOM Civil Affairs Planning Teams (CAPT) and the active duty Civil Affairs force. If any ASCCs lack the ability to add this planning staff to their organization, the ASCC planning staffs could be assigned to the CASOC with duty at their respective ASCC. Having a multi-component planning staff would provide the Army with a persistent Civil Affairs planning capability for operational planning. The reserve personnel could then be utilized for augmentation as needed and provide subject matter expertise on phase four and five operations.

With this recommended Civil Affairs force structure, the functional specialist cells would be consolidated from the CACOMs and battalions and realigned under each of the five reserve brigades. Each brigade headquarters would have a functional specialty company (Appendix P) that would be composed of four cells. The cells would have each of the six functional specialty sections: social and humanitarian services, civil security, rule of law, governance, economy and infrastructure, and homeland and integration, with a size of thirty-one personnel per cell derived from the size of former CACOM functional specialty cells. The consolidation of the functional specialists within a company would facilitate easier tracking, training, and dwell-to-deployment management. The recently formed Institute for Military Support to Governance (IMSG) would only have five headquarters to contact for any personnel management or training actions. Moreover, the multi-component structure would allow a portion of the functional specialty capability to rapidly respond if required, while the preponderance of the functional specialty company would be drawn from the reserve Civil Affairs force.

The elimination of four brigades is required to reduce duplication of effort and improve the overall reserve unit manning strength. To address the problem of duplication of effort, the 361st, which supports U.S. Army Europe (USAREU), and the 322nd, which supports U.S. Army Pacific (USARPAC), would be disbanded. Within the current force structure, one CACOM and one brigade within USACAPOC already support the European region, while one CACOM and two brigades already support the Pacific region. The 361st and the 322nd thus provide redundant capabilities that already exist within the reserve force and, therefore, can be eliminated with impacting operations.

With this optimization of the force, unit manning strength could be improved, leading to increased operational and training efficiencies. Reducing the force size would also allow multi-component units to train and deploy as organic units. This would result in more cohesive and capable units than the ad hoc units the reserves historically have deployed. The ranks of Major, Captain, Master Sergeant, and Sergeant First Class are the most critical ranks within any civil affairs force. We estimate that this shift would increase the manning of those ranks by 17 percent over the previous personnel structure (see Appendix G).

## **B. OPERATIONAL**

The active and reserve military forces have deployment-to-dwell-time ratio policies that must be followed. The Army separates deployment to dwell-time ratios into three categories: steady state, surge, and full surge. Under our proposal, the active force during surge operations would maintain a 1:2 deployment to dwell-time ratio. This would mean one year of deployment, and two years of dwell-time before each unit could be scheduled to deploy again. The reserves during surge conditions would be authorized a 1:4 ratio. The importance of this restriction was shown in 2003, when during surge conditions, the reserves sent more forces than they could sustain. “USACAPOC had 5,481 USAR [U.S. Army Reserve] and 207 active duty CA personnel assigned. Of those, 2,559 CA Soldiers (47 percent) were deployed in support of CENTCOM [U.S. Central Command] missions” (Van Roosen, 2009, p. 3), despite existing policies that limited deployment to dwell-time ratios to 1:4. Since the reserves deployed close to half of their force, by policy it would require four more years before those units and personnel could deploy again. As a result, this action greatly complicated future reserve unit mobilization and deployments, reduced the level of consistent Civil Affairs support, and forced reserve Civil Affairs soldiers to maintain an operational tempo close to the active duty force. If the reserves had instead adhered to the existing deployment policies, the conventional forces would have received a more consistent level of support throughout Afghanistan and Iraq.

## **1. CME Missions Sourced with More Emphasis on Phases 0 and 1**

Bringing the 85th Civil Affairs Brigade under USASOC would facilitate more emphasis on Phase 0 (shape) and Phase 1 (deter) operations. The 85th would be able to source the remaining CMSE missions that the 95th has not been able to man. The ability to focus on Phase 0 and 1 operations would have a profound impact on operations and the conventional force.

Special operations conducted during the shape and deter phases can hasten or delay the employment of a task force, and provide more time for the joint force commander to make a decision or explore alternative options. More importantly, optimal use of special operations could eliminate the threshold completely and obviate the establishment of a joint task force or the need for a large-scale conventional force deployment. (U.S. Army, 2012, p. 7)

LTC Fritz Little demonstrates (Appendix H) how the grouping of geographically aligned battalions from the 95th and the 85th could support special operations and conventional forces. Three persistent engagement missions (PE) similar to the Civil Military Engagement (CME) mission could be sourced for U.S. Special Operations Command (USSOCOM), while providing one global response force company dedicated to each ASCC. Three other companies can be utilized as direct support (DS) for either the conventional or special operations forces. The missions that the DS companies could support would consist of both Joint Combined Exchange Training (JCET) missions and Theater Security Cooperation Plans (TSCP). This balance of conventional and special operations support would provide the Army with the necessary active duty civil affairs capabilities while setting the conditions for reserve civil affairs force mobilization (Appendix I).

Managing the optimal relationship between Army special operations forces, Army conventional forces, joint forces, and indigenous security forces and institutions can prevent future conflict or mitigate the frequency and duration of a potential future crisis. (U.S. Army, 2012, p. 7)

## **2. Operationalized BDE HQ 1:1**

By Civil Affairs doctrine, Field Manual 3-57, the USASOC Civil Affairs brigade headquarters is a rapidly deployable element, which “provid[es] USASOC with a

responsive, flexible, and modular [Civil Affairs] force package. While serving in an initial-entry role during contingency operations, the brigade is able to transition with the follow-on [Civil Affairs] forces supporting conventional forces” (U.S. Army, 2011, pp. 2–4). Unfortunately, having only one USASOC Civil Affairs brigade headquarters makes the sustainment of a forward deployed brigade headquarters untenable. A portion of the brigade headquarters could be deployed only once for a limited time. However, by unifying the commands and making the command structure more streamlined, in a manner similar to what was directed by the Goldwater Nichols Act, a deployable brigade headquarters would be possible. With two active duty brigade headquarters, and five multi-component reserve brigade headquarters subordinate to one command, the concept of an operationalized brigade becomes more feasible and sustainable. The 85th or 95th brigade headquarters could be the initial entry headquarters with the other active duty brigade headquarters ready to replace them when required. Having two active brigade headquarters would allow the reserve forces time to start the mobilization process of the necessary headquarters and personnel needed for each operation.

### **C. ORGANIZATIONAL**

A single multi-component command structure with an optimized reserve force would increase organizational efficiency, as demonstrated by the dual-status commander concept for U.S. Northern Command’s (NORTHCOM) support to civil authority mission. Under our proposal, the Army would have a single organization that receives requests for forces (RFF), assess the feasibility, and ultimately deploys civil affairs forces in support of the Geographic Combatant Commanders (GCC) and the Theater Special Operations Commands (TSOC) around the world. A consolidated civil affairs command would increase the efficiency of requesting civil affairs forces and allow the command to provide the most appropriate capability to meet the intent of the GCC or TSOC commander. With regard to funding, the Department of Defense (DoD) and the Army would immediately see cost savings associated with Operation and Maintenance, Army Reserve (OMAR) funds, with reduction of the CACOMs and the elimination of the four brigades. For fiscal year 2010, the USACAPOC headquarters and the four CACOMs were allocated a total of \$41.5 million in OMAR funding (U.S. Army Civil Affairs and

Psychological Operations Command, 2010, p. 5). Based on our proposed optimization of the reserve force, the DoD would see an immediate cost savings of approximately \$8.5 million from the four brigades and additional savings from the elimination of the USACAPOC headquarters that accounts for 47 percent of their total OMAR budget (p. 5).

Additionally, there would be substantial cost savings in removing the six civil affairs battalions and the USACAPOC headquarters off airborne status (including medical expenses associated with airborne injuries). Based on U.S. Forces Command's (USFORSCOM) direction, the 85th Civil Affairs Brigade would remain the primary Civil Affairs force to be employed by the General Purpose Forces (GPF) to support Civil Affairs Operations (CAO) and Civil Military Operations (CMO) for deploying units, as well as providing persistent support to the ASCC for Theater Security Cooperation (TSC) and rapidly deployable Civil Affairs elements for Humanitarian Assistance/Disaster Relief (HA/DR) and other contingency operations (OCO) (U.S. Forces Command, 2011, p. 1). The consolidation of the functional specialists within companies at the brigade level would facilitate increased oversight with regard to validating qualifications. The proposed Institute for Military Support to Governance (IMSG) could further support the reserve Civil Affairs by developing validation criteria and certification for functional specialists (U.S. Army John F. Kennedy Special Warfare Center and School, 2013). In sum, the proposed single multi-component Civil Affairs command would increase organizational efficiency by eliminating redundancies and matching DoD requirements with operational capabilities.

#### **D. TRAINING**

The consolidation of the active and the reserve components of the three separate civil affairs organizations within the U.S. Army would also increase the efficiency of training and manning the force. As demonstrated by the Federal Law Enforcement Training Center (FLETC) model of training for law enforcement within the Department of Homeland Security (DHS), the Civil Affairs command could support a single U.S. Army standard for the basic Civil Affairs qualification that would be appropriate

(curriculum and length) for active and reserve soldiers. Civil Affairs students would be instructed by a combination of active and reserve instructors to capitalize on operational experiences from the entire spectrum of CAO and CMO. The single standard would comply with Army Directive 2012–08 (Army Total Force Policy) that dictates “standards for qualification and professional development will be the same for [active component] and [reserve component] personnel” (Secretary of the Army, 2012, p. 2). The single standard would also facilitate the primary intent for Army Directive 2012–08 (Army Total Force Policy): “an integrated operational force to provide predictable, recurring and sustainable capabilities” for U.S. military requirements (p. 1).

Upon completion of the basic Civil Affairs qualification course, reserve soldiers would return to their home station and fill a Civil Affairs billet. A single Civil Affairs command would have a vested interest in training and placing a newly qualified Civil Affairs soldier into a valid Civil Affairs billet within the reserves. Active duty Civil Affairs personnel would remain at U.S. Army John F. Kennedy Special Warfare Center and School (USAJFKSWCS) for advanced training consisting of the following: language training, regional studies, airborne school (Fort Benning, Georgia), and survival training. Additionally, active duty Civil Affairs units would conduct pre-mission training (PMT) that may incorporate additional advanced training for specific mission sets similar to the additional training qualifications for U.S. Secret Service agents within the DHS. One Civil Affairs command would also be able to support qualification and operational training more effectively with tasking authority for all Civil Affairs personnel.

## **E. CHALLENGES TO IMPLEMENTATION**

### **1. Culture**

The current culture that resides within the Civil Affairs community makes this optimized unification difficult to implement. The culture is one of mistrust and an “us-and-them” mentality among all three units. Between the active and reserves, the 2006 “divorce” has left significant residual emotional baggage for the reserves. The reserves vividly recall the day they were placed subordinate to the reserve command and were no longer coded as a special operations force. The reserve’s perceived exclusion, and their



differing paradigm from the active force on how Civil Affairs should operate, has perpetuated this negative culture. In addition, a partial “us-and-them” mentality exists between the two active duty brigades. The 95th is the only brigade that is coded as a special operations unit, which is interpreted by some as a mark of superiority even though the 85th is largely comprised of personnel from the 95th. This culture among the Civil Affairs community has bred mistrust and has prevented Civil Affairs from developing a unified message and direction for the future. To produce a successful unification, trust must be built, and the new CASOC will have to go through an organizational unlearning process.

Building trust among the units needs to occur to promote the kind of open dialogue required for change. Anklam (2007) in *Net Work* states, “In the development of a network, trust is the factor that takes perhaps the longest to build and is the one that can be destroyed with a single act” (p. 101). She divides trust into two types: competence-based and benevolence-based trust. Competence-based trust is defined as “I trust you know what you are talking about” (p. 100), and benevolence-based trust is defined as “I trust you will act without malice and help me the best you can” (p. 100). To some degree, competence-based trust among the units has been established. The majority of the active and reserve Civil Affairs force has deployed to Afghanistan or Iraq and has conducted Civil Affairs Activities. However, there is still disagreement on what those activities should be and how their effectiveness should be measured. There are also disagreements on the standard requirements to enter Civil Affairs, and the length of the Civil Affairs qualifying course. These are not minor issues, but the shared operational experiences do provide some level of credibility for all three units. Unfortunately, benevolence-based trust has yet to be formed, and will likely take time to develop. It will take leaders who are willing to listen, who will take the time to frequently interact with all units during the reorganization process, and unify rather than divide the force. Building the trust between the units could then lead to a “commitment to the collective”: the individual’s commitment to the total Civil Affairs force that supports the unified organization’s purpose, providing the Army with a Civil Affairs capability through all six phases of

operations. Until this “commitment to the collective” (Anklam, 2007, p. 99) occurs, unity of effort and Civil Affairs unit cohesion will not exist.

The new CASOC would therefore have to go through an organizational unlearning process for it to rapidly become an efficient organization. This unlearning process is necessary due to the change of the headquarters structure from single component, or solely active or reserve, into multi-component organizations. A merging of day-to-day operational routines would have to be established in place of previously existing routines from the single component headquarters. In order to do this, individuals will need to recognize that some of their old routines and systems are no longer current and have been replaced. “Unlearning at the organizational level requires unlearning at the individual level” (Tsang & Zahra, 2008, p. 1444). Failure to adapt to the new organization would only impede the speed at which the headquarters would be capable of efficiently executing its core functions. “Individual unlearning is often a cumbersome and energy-consuming process . . . [as] habits and routines are difficult to change or abandon” (p. 1445). Also, “at the individual level, learning anxiety and survival anxiety may inhibit people from unlearning what they know in order to learn something new” (p. 1446). The organization and the individuals who make the organization will therefore have to move past their old organizational memory in order to start making a cohesive functioning unit. This process will take time, patience, and strong leadership from both officers and non-commissioned officers.

## **2. Qualification Standards Versus Civil Affairs**

There are two significant challenges with regard to the civil affairs qualification courses at Fort Bragg, North Carolina; Joint Base McGuire-Dix-Lakehurst, New Jersey; and Fort Hunter Liggett, California. First, the Civil Affairs branch must develop a single Army qualification standard regardless of component: one program of instruction for non-commissioned officers and one program of instruction for commissioned officers. The single qualification standard would have to be long enough to provide the required instruction, but short enough to minimize the financial impact of the training for reservists. Advanced training for active duty soldiers would still be required in order to

support TSOCs. Second, a multi-component instructor staff at each location would implement the program of instruction. Active duty instructors would be required to execute a permanent change of station to one of the training centers in New Jersey or California, and reservists would be placed on orders with duty at Fort Bragg to be instructors. The mixture of active duty and reserve instructors would expand the pool of operational knowledge at each location. Striking the right balance—content versus time—for a single qualification standard and building a multi-component instructor staff will enhance integration and interdependence within the Civil Affairs community, as well as to the customers: ASCCs, TSOCs and the GCCs.

### **3. Bill Payers**

In the current period of downsizing, the creation of a multi-component command with an active duty brigadier general as the commander is a zero sum game for the Army. The Army would have to eliminate one active duty brigadier general billet and a portion of the staff in order to create a multi-component command with an active duty one-star command billet for civil affairs. The 95th and 85th would decrease their staffs and reinvest senior positions within the new command. This command would eliminate the requirement for USACAPOC's six general officers: five brigadier generals and one major general. Based on the Defense Manpower Data Center (DMDC) Reserve Components Common Personnel Data System, the reduction of the six USACAPOC generals would reduce the overall reserve general officer strength from 107 to 101 general officers: 32 major generals and 69 brigadier generals (Office of the Deputy Under Secretary of Defense for Military Community and Family Policy, 2011, p. 60). Although the replacement of USACAPOC for a smaller and more streamlined command has clear advantages, this particular challenge may raise additional political barriers.

## **F. CONCLUSION**

The separation of active duty and reserve Civil Affairs forces was labeled as a divorce in 2006, but perhaps it can now be repaired. Our evidence and analysis indicates that a single multi-component command led by an active duty brigadier general would be the optimal Civil Affairs force structure, based on operational, training, and

organizational efficiencies. However, the looming fiscal constraints and final Army end strength may create barriers to the implementation of this recommendation. With these constraints in mind, a hybrid recommendation that optimizes both the active duty and reserve forces may be more feasible. However, any such hybrid formulation should still conform to our primary recommendation that the single command be multi-component and led by an active duty general officer. In addition, given our recommendations to optimize the reserve force, additional research must be conducted in order to determine which units should be eliminated to cause the least impact on reserve personnel and their overall capabilities.

THIS PAGE INTENTIONALLY LEFT BLANK

# APPENDIX A. CURRENT CIVIL AFFAIRS STRUCTURE

Appendix A depicts the current Civil Affairs force structure within the U.S. Army.

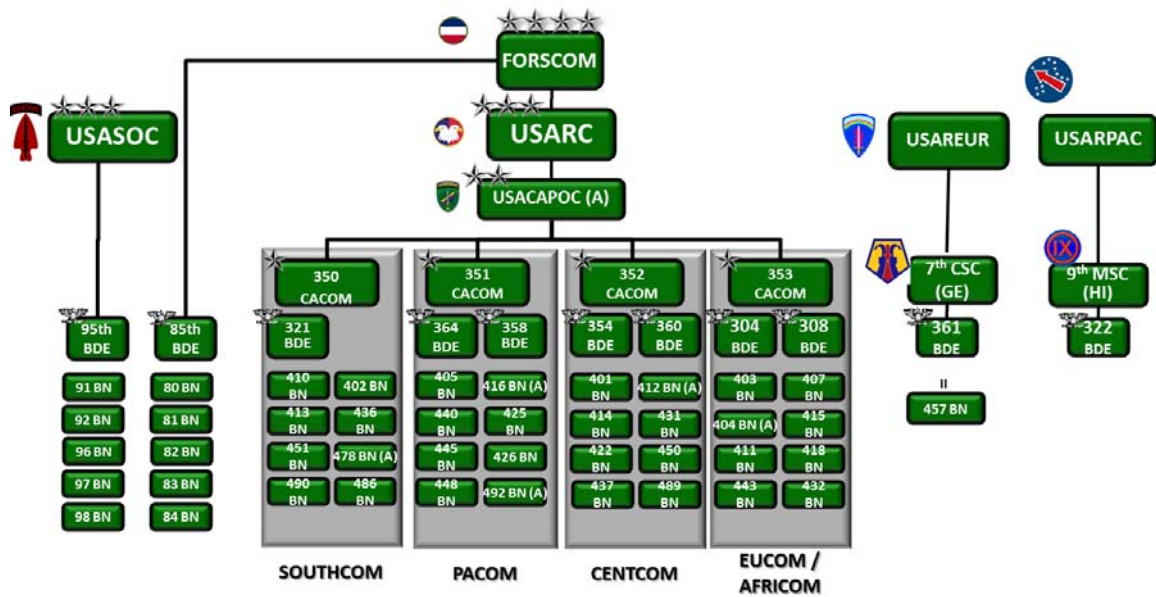

THIS PAGE INTENTIONALLY LEFT BLANK

## APPENDIX B. DEMAND SPECTRUM MATH

Appendix B depicts the quantity of Civil Affairs companies required based on the following two items: (1) Brigade Combat Teams (BCT) and Maneuver Enhancement Brigades (MEB) within the Army and (2) the Army Forces Generation (ARFORGEN) model.







NAVAL  
POSTGRADUATE  
SCHOOL

UNCLASSIFIED//FOUO

### Demand Spectrum Math



CURRENT STATE	FULL SURGE (Example)	SURGE ROTATION	STEADY STATE ROTATION
 132 X CA	 67 X CA	 62 X CA	 59 X CA
	$(35/2) - (25/2) = 5$ $(5 \times 4) + 47 = 67$	$(35/3) - (25/3) = 3$ $(3 \times 5) + 47 = 62$	$(35/4) - (25/4) = 2$ $(2 \times 6) + 47 = 59$
33 BCTs (AC) 2 MEBs (AC) 35 Total 28 BCTs (RC) 19 MEBs (RC) 47 Total 25 CA COs (AC)	33 BCTs (AC) 2 MEBs (AC) 35 Total 28 BCTs (RC) 19 MEBs (RC) 47 Total 25 CA COs (AC) AA RATIO - 1:1 RC RATIO - 1:3	33 BCTs (AC) 2 MEBs (AC) 28 BCTs (RC) 19 MEBs (RC) 25 CA COs (AC) AA RATIO - 1:2 RC RATIO - 1:4	33 BCTs (AC) 2 MEBs (AC) 28 BCTs (RC) 19 MEBs (RC) 25 CA COs (AC) AA RATIO - 1:3 RC RATIO - 1:5 2

UNCLASSIFIED//FOUO



THIS PAGE INTENTIONALLY LEFT BLANK

## APPENDIX C. DEMAND SPECTRUM AND RESERVE CIVIL AFFAIRS

Appendix C depicts the Civil Affairs companies required based on the following items: (1) the current Civil Affairs forces (2) Brigade Combat Teams (BCT) and Maneuver Enhancement Brigades (MEB) within the Army and (3) Army Forces Generation (ARFORGEN) model.



UNCLASSIFIED//FOUO

### Demand Spectrum & Reserve Civil Affairs

**ASSUMPTIONS:**

1. RC BCTs and MEBs will not increase or decrease.
2. AC Conventional CA will not increase or decrease.
3. Conventional CA Companies will support BCTs and MEBs.

**DEMAND SPECTRUM:**

1. Steady-State Rotation
  - a) AC Ratio – 1:3 (4-year Cycle)
  - b) RC Ratio – 1:5 (6-year Cycle)
2. Surge Rotation
  - a) AC Ratio – 1:2 (3-year Cycle)
  - b) RC Ratio – 1:4 (5-year Cycle)
3. Full Surge
  - a) AC Ratio – 1:1 (2-year Cycle)
  - b) RC Ratio – 1:3 (4-year Cycle)

Reference: AR 529-29 (Army Force Generation)

CURRENT RC CA Companies	FULL SURGE ROTATION	SURGE ROTATION	STEADY-STATE
132	67	62	59

**The Delta: USACAPOC retains 65 additional CA companies above what is required for the planned inventory of BCTs and MEBs in a full surge rotation.**

Component Type	BCTs	MEBs
Active Component	33	2
Reserve (RC)	0	3
National Guard (RC)	28	16

**Key Take Away: USACAPOC can reduce 49 percent of their tactical CA companies without any loss of operational capability.**

UNCLASSIFIED//FOUO

THIS PAGE INTENTIONALLY LEFT BLANK

## APPENDIX D. U.S. ARMY RESERVE, CIVIL AFFAIRS STRENGTH

Appendix D depicts U.S. Army Civil Affairs and Psychological Operations Command's (USACAPOC) personnel strength by rank, authorizations and qualification (branch/military occupational skill [MOS]).

# USAR CA STRENGTH

25 January 2011

Inventory Data Systems are ITRS and eCARDART

USAR	USACAPOC Authorized	Inventory awarded Branch / MOS	%
COL	73	69	95%
LTC	328	254	77%
MAJ	653	286	44%
CPT	1050	207	20%
<b>Total</b>	<b>2104</b>	<b>816</b>	<b>39%</b>
SGM	23	16	70%
MSG	420	196	47%
SFC	726	305	42%
SSG	741	557	75%
SGT	450	613	136%
E3-E4	638	1232	193%
<b>Total</b>	<b>2998</b>	<b>2919</b>	<b>97%</b>

THIS PAGE INTENTIONALLY LEFT BLANK

## APPENDIX E. CIVIL AFFAIRS QUALIFICATION COURSE RESERVE GRADUATES

Appendix E depicts U.S. Army Civil Affairs and Psychological Operations Command's (USACAPOC) graduates of Civil Affairs qualification schools by rank and year.

1LT(P) OR CPT CCC or equivalent graduate		2008		2009		2010		2011	
	AUG	137	MAR	67	OCT	85	APR	56	
			JUL	69	FEB	85	JUL	56	
				136	JUL	85	SEP	56	
						255		168	
									174

ALC (E6)		ALC (E6)		ALC (E6)		ALC (E6)		
AUG	32	JUL	71	FEB	32	NOV	16	
NOV	32	AUG	71	APR	32	DEC	16	
JUN	56		142	JUN	32	JAN	16	
	120			JUL	80	MAR	16	
					176	APR	16	
						MAY	16	
						MAY	16	
						JUL	16	
							128	
								141

SLC (E7)		SLC (E7)		SLC (E7)		SLC (E7)		
AUG	32	JUL	48	FEB	32	DEC	18	
JAN	28	AUG	48	APR	32	FEB	18	
JUN	16		96	JUN	32	MAY	18	
	76			JUL	32	JUN	18	
					128	AUG	18	
							90	
								97

THIS PAGE INTENTIONALLY LEFT BLANK

## **APPENDIX F. RESERVE MISSION REQUIREMENTS**

Appendix F depicts U.S. Army Civil Affairs and Psychological Operations Command's (USACAPOC) missions, locations, personnel, and time periods. In fiscal year 2014 U.S. Army Civil Affairs and Psychological Operations Command (USACAPOC) will have 23 mission requirements to source for Operations Enduring Freedom-Afghanistan (OEF-A), Joint Task Force-Horn of Africa, U.S. Southern Command (USSOUTHCOM), Operations Enduring Freedom-Kuwait (OEF-KU), and U.S. Central Command (USCENTCOM). There are 23 mission requirements, but only 389 personnel are required to fill all of the requirements. Three hundred and eight-nine personnel are roughly 13 percent of their total authorized force (U.S. Army Civil Affairs and Psychological Operations Command (USACAPOC), 2010).



FY 14														CA Company	CAPT	CATeam	CACOM	BOE	BN	Functional Specialists						
SECTOR	FTN	PAX	Location	UIC	UNIT	MOB-Date	Days Post-Mob	BOG	JAC Date	MOB Platform	A MOB ORD	DA AMEND ORD #	Remarks						RoL	Health	Economics	Infrastructure	Governance	Education		
DEF-A CA	1140006040	138	VARIOUS	WYBxx	412 CA BN	16-Feb-14	55		Jan-15					4	1											
	1140006413	3	KANDAHAR CAPT	WYB,YA	HHC 352 CACOM	11-Oct-13	51	Sep-14	Dec-12	JBMOL																
	1140001855	3	GHAFZ	WRUKY7	402 CA BN	2-Sep-13	63	Oct-14	Feb-13	JBMOL																
	1140008020	2	VARIOUS (ROLET)	WYB,Y3	HHC 352 CACOM	8-Sep-13	51	Sep-14	Dec-12	JBMOL																
	1140008022	2	VARIOUS (ROLET)	WYB,Y4	HHC 352 CACOM	8-Sep-13	51	Sep-14	Dec-12	JBMOL																
HOA CA	1140008023	2	VARIOUS (ROLET)	WYB,Y5	HHC 352 CACOM	8-Sep-13	51	Sep-14	Dec-12	JBMOL																
	1140008024	2	VARIOUS (ROLET)	WYB,Y6	HHC 352 CACOM	8-Sep-13	51	Sep-14	Dec-12	JBMOL																
	114098LCAB3	37	CAMP LEMONIER D/BOUT	WYD,Y7	407 CA BN	16-Feb-14	55	Jan-15	Feb-13	JBMOL				1												
	114098LCAB5	5	CAMP LEMONIER D/BOUT	WYB,Y6	HHC 353 CACOM	25-Sep-13	48	Aug-14	Dec-12	JBMOL					1	1										
	114098LCAB9	32	CAMP LEMONIER D/BOUT	WYD,GAD	A407 CA BN	16-Feb-14	53	Jan-15	Feb-13	JBMOL					1											
SOUTHCOM	114098LCAB8	32	CAMP LEMONIER D/BOUT	WYD,Gax	B407 CA BN	16-Oct-13	48	Aug-14	Dec-12	JBMOL				1												
	114098LCAL5	3	CAMP LEMONIER D/BOUT	WYB,Y6	HHC 353 CACOM	21-Aug-13	48	Aug-14	Dec-12	JBMOL					1											
	8140000995	9	HOMESTEAD FL	WYD,Y7	413 CA BN	26-Feb-14	50	Dec-14	Feb-13	JBMOL																
	8140000998	4	PANAMA CITY PANAMA	WYD,Y8	413 CA BN	26-Feb-14	50	Dec-14	Feb-13	JBMOL					1											
	8140000998	4	JAMAICA	WYD,Y9	413 CA BN	26-Feb-14	50	Dec-14	Feb-13	JBMOL																
DEF-RU	8140000999	4	DOMINICAN REPUBLIC	WYD,YA	413 CA BN	26-Feb-14	50	Dec-14	Feb-13	JBMOL																
	8140000997	1	HONDURAS	WZ2,Yax	HHC 350 CA BN	8-Oct-13	28	Jul-14	Dec-12	JBMOL					1											
	8140000998	1	JAMAICA	WZ2,Yax	HHC 350 CA BN	8-Oct-13	28	Jul-14	Dec-12	JBMOL					1											
	8140000999	3	HONDURAS	WYD,Yax	413 CA BN	8-Oct-13	28	Jul-14	Dec-12	JBMOL						1										
	8140000991	4	GUATEMALA	WYD,Yax	413 CA BN	8-Oct-13	28	Jul-14	Dec-12	JBMOL						1										
CENTCOM	8140000992	4	HONDURAS	WYD,Yax	413 CA BN	8-Oct-13	28	Jul-14	Dec-12	JBMOL						1										
	1140004750	5	AMP JAN KUWAIT	WYB,Yax	HHC 352 CACOM	28-Apr-14	50	Feb-15		TBC					1											
	11400012270	9	TAMPA FL	WYB,Y1	HHC 352 CACOM	20-Sep-13	51	Sep-14	Dec-12	JBMOL						1										

FY 14.3														CA CDte	CAPT	CATe										
SECTOR	FTN	PAX	Location	UIC	UNIT	MOB-Date	Days Post-Mob	BOG	JAC Date	MOB Platform	A MOB ORD	DA AMEND ORD #	Remarks													
DEF-CA	1140006413	3	KANDAHAR (CAPT)	WYB,xx	HHC 352 CACOM	23-Jan-14	60	May-15							1											
	1140008020	2	VARIOUS (ROLET)	WYB,Y3	HHC 352 CACOM	23-Jan-14	51	Jan-15																		
	1140008022	2	VARIOUS (ROLET)	WYB,Y4	HHC 352 CACOM	23-Jan-14	51	Jan-15																		
	1140008023	2	VARIOUS (ROLET)	WYB,Y5	HHC 352 CACOM	23-Jan-14	51	Jan-15																		
HOA CA	114098LCAB8	32	CAMP LEMONIER D/BOUT	WYD,Gax	G407 CA BN	2-Jun-14	60	Apr-15						1												
	114098LCAL5	3	CAMP LEMONIER D/BOUT	WYB,Y6	HHC 353 CACOM	16-Jul-14	50	May-15							1											
SOUTHCOM	11400012270	9	TAMPA FL	WYB,xx	HHC 352 CACOM	30-Aug-14	50	Aug-15							1											
	8140000997	1	HONDURAS	WZ2,Yax	HHC 350 CACOM	25-Jan-14	50	Mar-15							1											
	8140000998	1	JAMAICA	WZ2,Yax	HHC 350 CACOM	25-Jan-14	50	Mar-15							1											
	8140000998	5	HONDURAS	WYB,xx	401 CA BN	25-Jan-14	50	Mar-15								1										
	8140000991	4	GUATEMALA	WYB,xx	401 CA BN	25-Jan-14	50	Mar-15								1										
8140000992	4	HONDURAS	WYB,xx	401 CA BN	25-Jan-14	50	Mar-15								1											
Black: Projected Mobilization Date																										
Blue: Requested Move at JRC																										
Green: PMSD based on MOB Order																										
Red: Issues Being Worked/Cancelled																										
Total Number Deployed FY11	389													8	11	8										
PET Support	0	0%																								
CAPT	45	12%																								
FS (ROL)	16	4%																								

## APPENDIX G. OPTIMIZED FORCE STRENGTH (RESERVES)

Appendix G depicts U.S. Army Civil Affairs and Psychological Operations Command's (USACAPOC) personnel strength by rank, authorizations, and on-hand personnel.

CA	Authorizations	On-Hand	Percent Strength
COL	12	142	1183%
LTC	257	403	157%
MAJ	445	286	64%
CPT	875	207	23%
Total	1589	816	51%
CA	Authorizations	On-Hand	Percent Strength
CSM/SGM	23	67	65%
1SG/MSG	381	251	66%
SFC	717	465	65%
SSG	711	666	94%
SGT	554	598	108%
SPC	729	1241	170%
Total	3115	3288	106%

THIS PAGE INTENTIONALLY LEFT BLANK

## **APPENDIX H. LITTLE'S SOURCING MATRIX**

Appendix H, the figure created by LTC Fritz Little, depicts how the grouping of like geographically aligned battalions from the 95th and the 85th can support special operations and conventional forces. Three persistent engagement missions (PE) similar to the CME mission could be sourced for U.S. Special Operations Command (USSOCOM), while providing one global response force (GRF) company dedicated to each Army Service Component Command (ASCC). Three other companies can be utilized as direct support (DS) for either the conventional or special operations forces. The missions that the direct support (DS) companies could support would consist of; Joint Combined Exchange Training (JCET) missions and Theater Security Cooperation Plans (TSCP) (Little, 2013).

CA BN	Company	2014		2015		2016		2017		2018		2019	
		OCT-MAR	APR-SEP	OCT-MAR	APR-SEP	OCT-MAR	APR-SEP	OCT-MAR	APR-SEP	OCT-MAR	APR-SEP	OCT-MAR	APR-SEP
80 EUCOM	A	PE	DS	T	PE	DS	DS	T	PE	DS	ORF	T	PE
	B	PE	DS	ORF	T	PE	DS	T	PE	DS	SPT	T	PE
	C	PE	DS	DS	T	PE	DS	ORF	DS	PE	DS	T	PE
	D	T	PE	DS	T	PE	DS	DS	T	PE	DS	ORF	T
	E	T	PE	DS	ORF	T	PE	DS	T	PE	DS	SPT	T
92 EUCOM	A	T	PE	DS	DS	T	PE	DS	ORF	T	PE	DS	T
	B	ORF	T	PE	DS	T	PE	DS	DS	T	PE	DS	ORF
	C	SPT	T	PE	DS	ORF	T	PE	DS	T	PE	DS	DS
	D	DS	T	PE	DS	DS	T	PE	DS	ORF	T	PE	SPT
	E	DS	ORF	T	PE	RS	T	PE	DS	DS	T	PE	DS
	F	DS	SPT	T	PE	DS	ORF	T	PE	DS	T	PE	DS
81 SOUTHCOM	A	ORF	T	PE	DS	T	PE	DS	DS	T	PE	DS	ORF
	B	SPT	T	PE	DS	ORF	T	PE	DS	T	PE	DS	SPT
	C	DS	T	PE	DS	SPT	T	PE	DS	ORF	T	PE	DS
	D	DS	ORF	T	PE	RS	T	PE	DS	SPT	T	PE	DS
	E	DS	SPT	T	PE	DS	ORF	T	PE	DS	T	PE	DS
98 SOUTHCOM	A	PE	DS	T	PE	DS	SPT	T	PE	DS	ORF	T	PE
	B	PE	DS	ORF	T	PE	DS	T	PE	DS	DS	T	PE
	C	PE	DS	SPT	T	PE	DS	ORF	T	PE	DS	T	PE
	D	T	PE	RS	T	PE	DS	SPT	T	PE	DS	ORF	T
	E	T	PE	DS	ORF	T	PE	RS	T	PE	DS	SPT	T
	F	T	PE	DS	SPT	T	PE	DS	ORF	T	PE	RS	T
82 AFRICOM	A	PE	SPT	T	PE	DS	DS	T	PE	DS	ORF	T	PE
	B	PE	DS	ORF	T	PE	DS	T	PE	DS	DS	T	PE
	C	PE	DS	SPT	T	PE	DS	ORF	T	PE	DS	T	PE
	D	T	PE	DS	T	PE	DS	DS	T	PE	DS	ORF	T
	E	T	PE	DS	ORF	T	PE	DS	T	PE	DS	DS	T
91 AFRICOM	A	T	PE	DS	SPT	T	PE	DS	ORF	T	PE	RS	T
	B	ORF	T	PE	DS	T	PE	DS	SPT	T	PE	DS	ORF
	C	DS	T	PE	DS	ORF	T	PE	DS	T	PE	DS	DS
	D	DS	T	PE	DS	SPT	T	PE	DS	ORF	T	PE	DS
	E	DS	ORF	T	PE	DS	T	PE	DS	DS	T	PE	DS
	F	DS	DS	T	PE	DS	ORF	T	PE	DS	T	PE	DS
83 CENTCOM	A	PE	DS	T	PE	DS	SPT	T	PE	DS	ORF	T	PE
	B	PE	DS	ORF	T	PE	DS	T	PE	DS	DS	T	PE
	C	PE	DS		T	PE	DS	ORF	T	PE	DS	T	PE
	D	T	PE	RS	T	PE	DS	SPT	T	PE	DS	ORF	T
	E	T	PE	DS	ORF	T	PE	RS	T	PE	DS	SPT	T
96 CENTCOM	A	T	PE	DS	DS	T	PE	DS	ORF	T	PE	DS	T
	B	ORF	T	PE	DS	T	PE	DS	SPT	T	PE	DS	ORF
	C	DS	T	PE	DS	ORF	T	PE	DS	T	PE	DS	DS
	D	DS	T	PE	DS	DS	T	PE	DS	ORF	T	PE	DS
	E	DS	ORF	T	PE	DS	T	PE	DS	SPT	T	PE	DS
	F	DS	DS	T	PE	DS	ORF	T	PE	RS	T	PE	DS
84 PACOM	A	PE	DS	T	PE	DS	DS	T	PE	DS	ORF	T	PE
	B	PE	DS	ORF	T	PE	DS	T	PE	DS	SPT	T	PE
	C	PE	DS		T	PE	DS	ORF	T	PE	RS	T	PE
	D	T	PE	DS	T	PE	DS	DS	T	PE	DS	ORF	T
	E	T	PE	DS	ORF	T	PE	DS	T	PE	DS	SPT	T
97 PACOM	A	T	PE	DS	DS	T	PE	DS	ORF	T	PE	DS	T
	B	ORF	T	PE	DS	T	PE	DS	DS	T	PE	DS	ORF
	C	DS	T	PE	DS	ORF	T	PE	DS	T	PE	DS	SPT
	D	DS	T	PE	DS	DS	T	PE	DS	ORF	T	PE	DS
	E	DS	ORF	T	PE	RS	T	PE	DS	DS	T	PE	DS
	F	DS	DS	T	PE	DS	ORF	T	PE	DS	T	PE	DS

## APPENDIX I. ROLE OF ARMY SPECIAL OPERATIONS

Appendix I depicts Army Special Operations through the full range of military operations (U.S. Army, 2012).

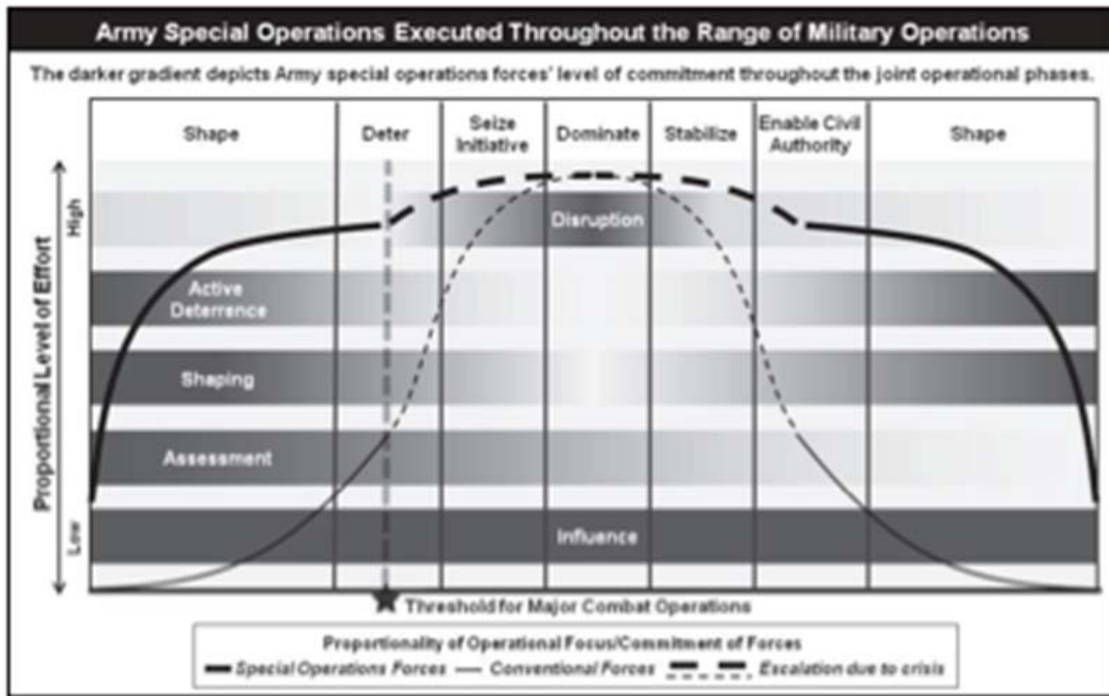

THIS PAGE INTENTIONALLY LEFT BLANK

# APPENDIX J. CIVIL AFFAIRS REORGANIZATION PROPOSAL #1 (ACTIVE DUTY CONSOLIDATION)

Appendix J depicts the active duty consolidation proposal.

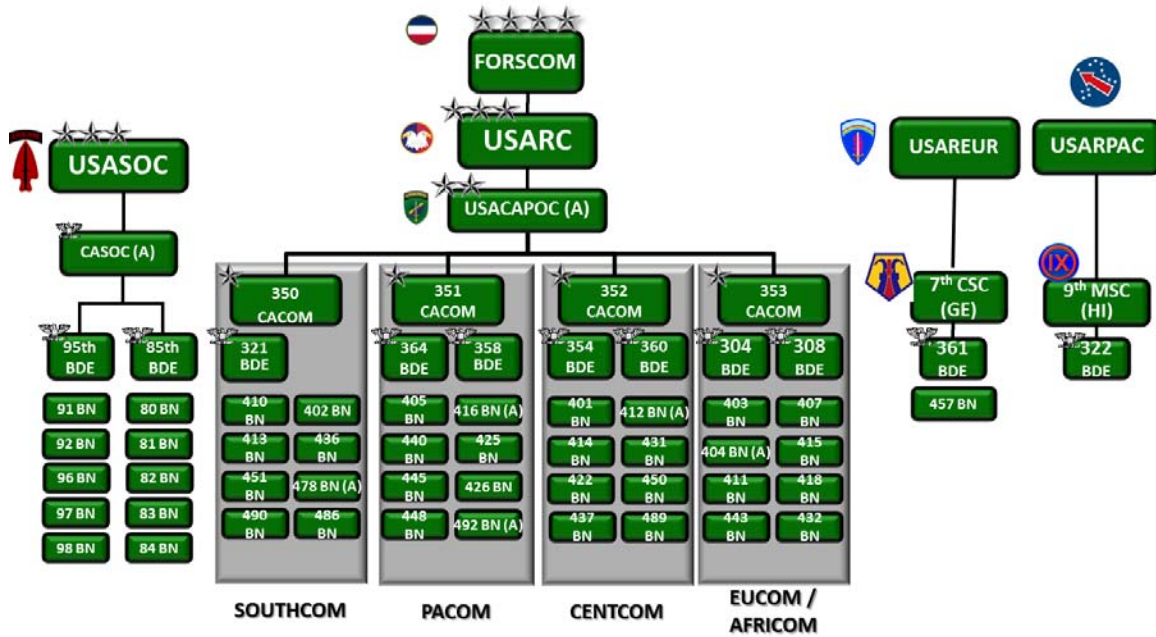



THIS PAGE INTENTIONALLY LEFT BLANK

# APPENDIX K. CIVIL AFFAIRS REORGANIZATION PROPOSAL #2 (TITLE 10 COMMAND CONSOLIDATION)

Appendix K depicts the Title 10 command consolidation proposal.

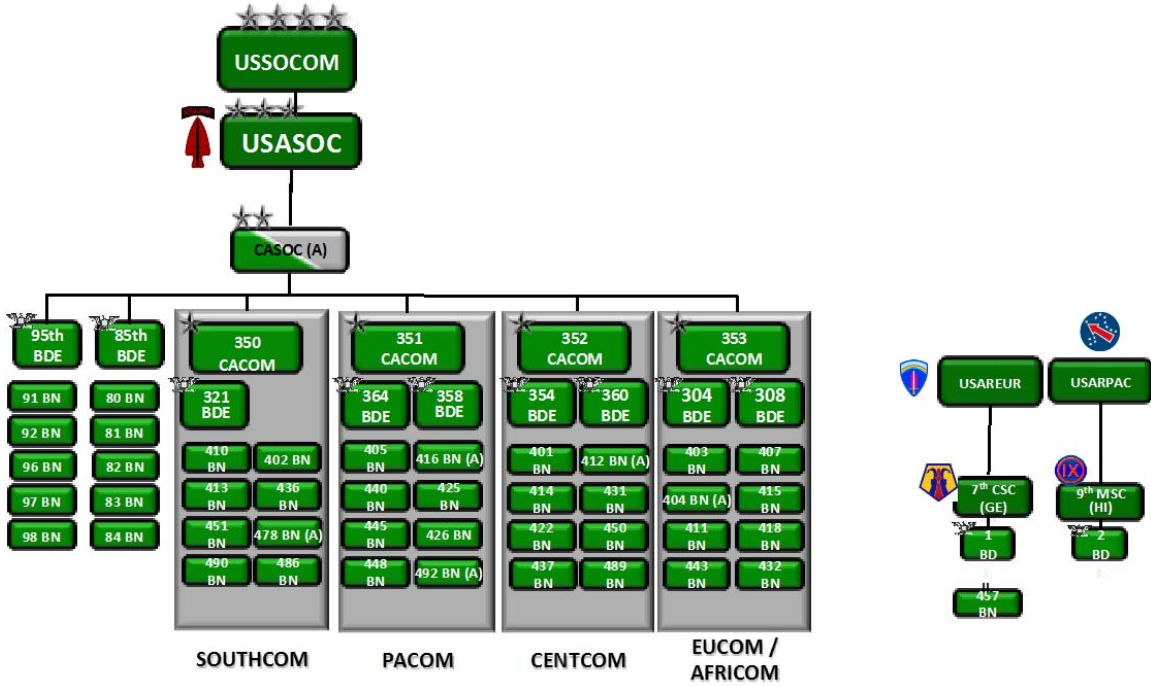

THIS PAGE INTENTIONALLY LEFT BLANK

# APPENDIX L. CIVIL AFFAIRS REORGANIZATION PROPOSAL #3 (ELIMINATION OF THE 85TH)

Appendix L depicts the elimination of the 85th proposal.

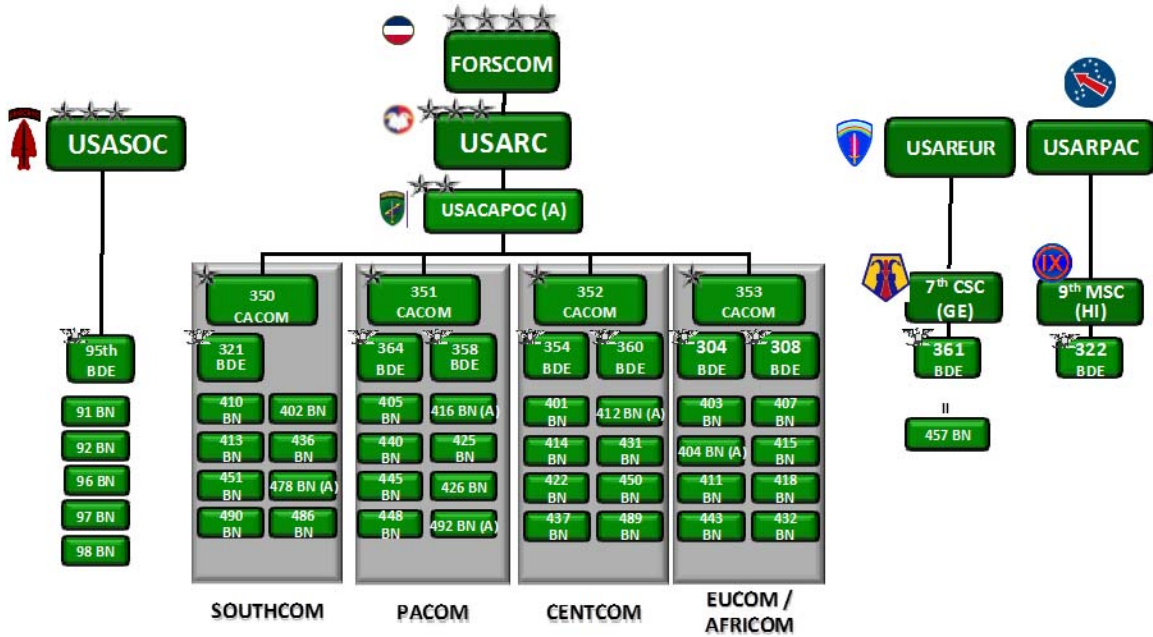

THIS PAGE INTENTIONALLY LEFT BLANK

## APPENDIX M. A UNIFIED MULTI-COMPONENT COMMAND

Appendix M depicts the authors' proposal: a unified multi-component command with an optimized reserve force.

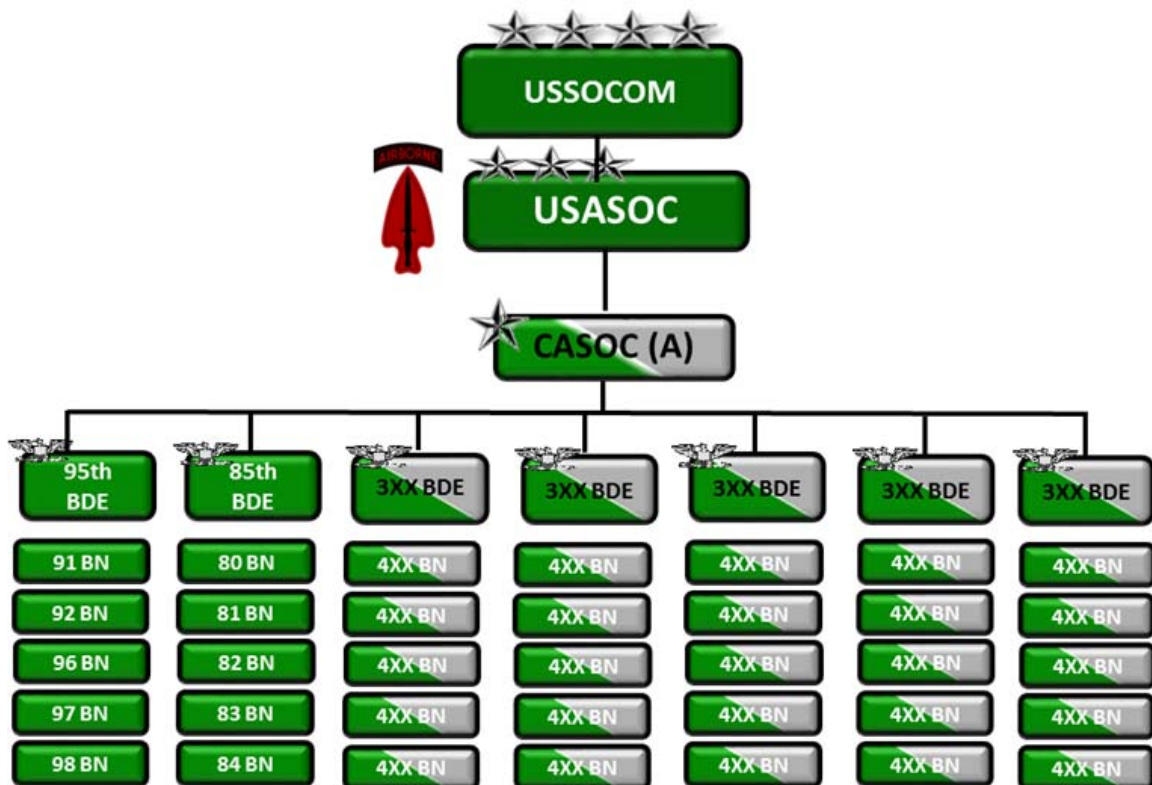

### ASCC CA Staff



THIS PAGE INTENTIONALLY LEFT BLANK

## APPENDIX N. CIVIL AFFAIRS SPECIAL OPERATIONS COMMAND HEADQUARTERS

Appendix N depicts the new Civil Affairs Special Operations Command (CASOC) with staff sections that mirror U.S. Army Special Operations Command (USASOC).

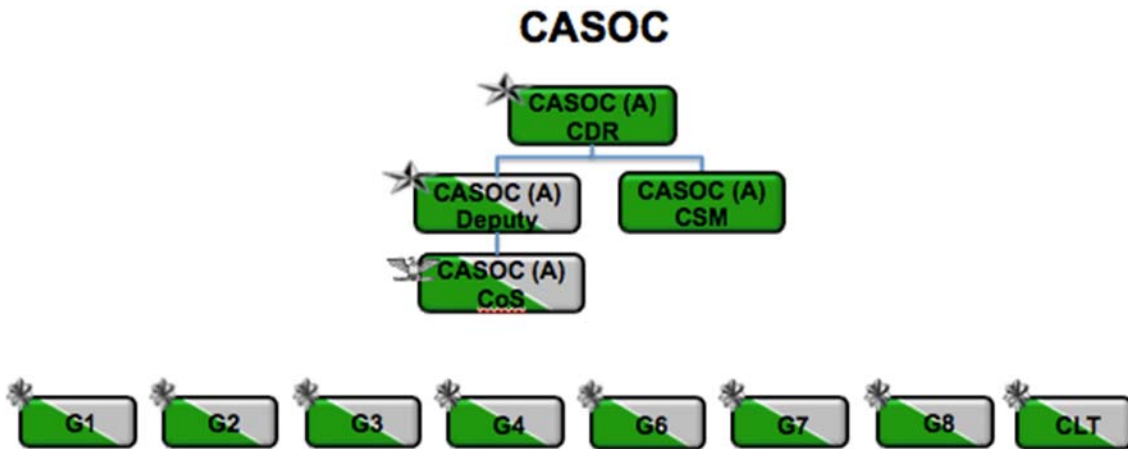



THIS PAGE INTENTIONALLY LEFT BLANK

## APPENDIX O. ARMY SERVICE COMPONENT COMMAND'S CIVIL AFFAIRS STAFF

Appendix O depicts the new Civil Affairs staff supporting the Army Service Component Commands (ASCC).

### ASCC CA Staff

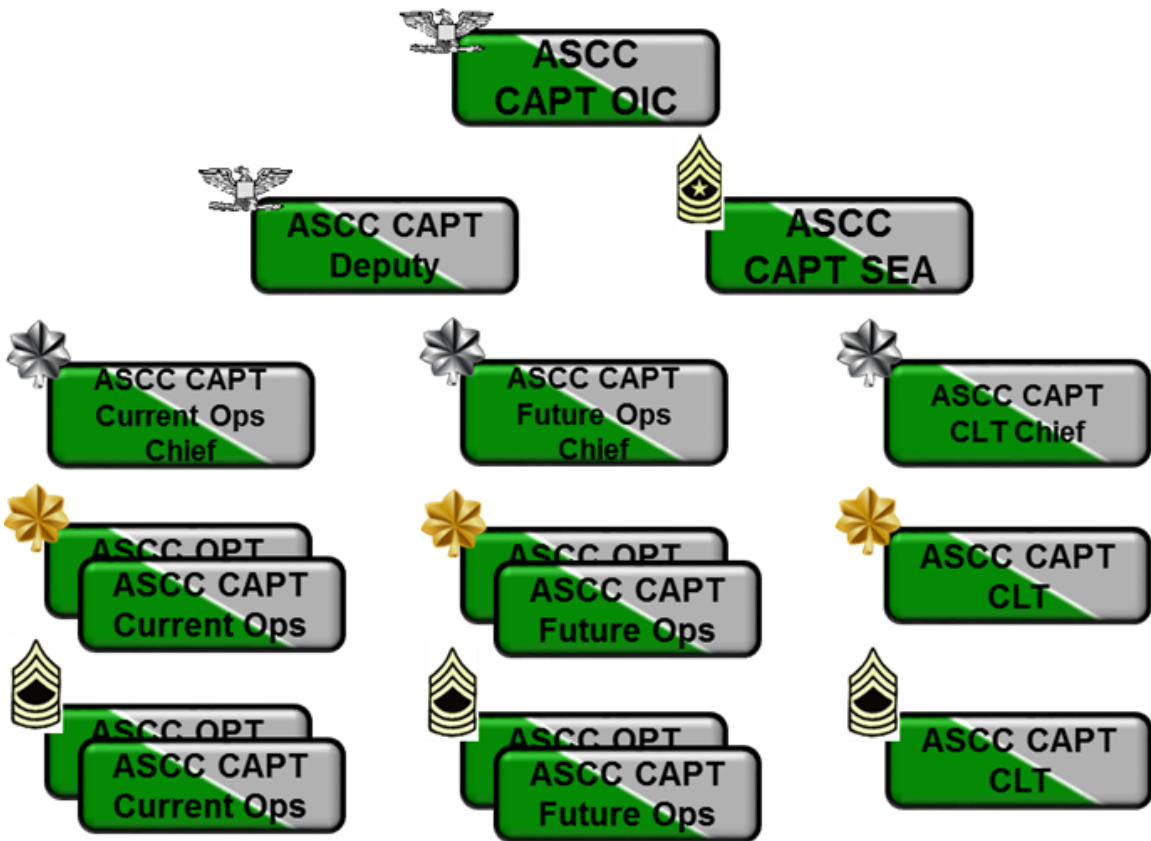

THIS PAGE INTENTIONALLY LEFT BLANK

## APPENDIX P. FUNCTIONAL SPECIALTY COMPANY

Appendix P depicts the new Functional Specialty company at the brigade level with six different Functional Specialty categories.

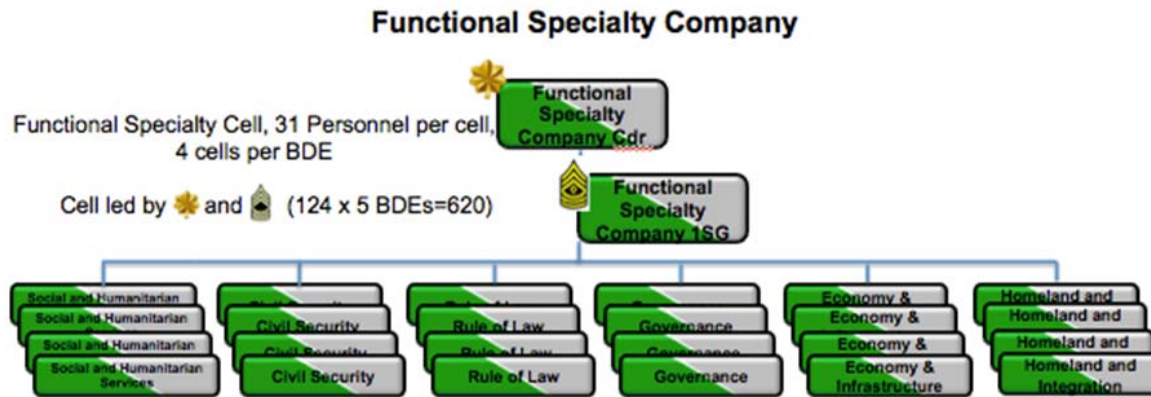

THIS PAGE INTENTIONALLY LEFT BLANK

## LIST OF REFERENCES

- Alaskan Command (ALCOM). (2011). *Factsheet*. Retrieved from Joint Base Elmendorf-Richardson website: [http://www.jber.af.mil/library/factsheets/factsheet\\_print.asp?fsID=5286&page=1](http://www.jber.af.mil/library/factsheets/factsheet_print.asp?fsID=5286&page=1)
- Anklam, P. (2007). *Net work*. Burlington, MA: Butterworth Heinemann.
- Baltos, C. (2012). *Army north helps prepare future dual-status commanders*. Retrieved from Army North website: <http://www.arnorth.army.mil/News/Army-North-helps-prepare-future-dual-status-comman.aspx>
- Besson, P. M. (1998). *The Goldwater-Nichols act, a ten year report card*. (No. P-98-2). Cambridge, MA: Program on Information Resources Policy.
- Castellanos, M. A. (2009). *Civil affairs—Building the force to meet its future challenges* (master's project). U.S. Army War College, Carlisle, PA. Retrieved from DTIC Online website: <http://oai.dtic.mil/oai/oai?verb=getRecord&metadataPrefix=html&identifier=ADA498021>
- City of Colorado Springs. (2012). *Waldo Canyon fire: Initial after action report*. Retrieved from richmedia.onset.freedom.com website: <http://richmedia.onset.freedom.com/colgazette/mccpuy-waldocanyonfireafteractionreport.pdf>
- City of Colorado Springs. (2013). *Waldo Canyon fire: Final after action review*. Retrieved from [http://www.springsgov.com/units/communications/ColoradoSpringsFinalWaldoAAR\\_3April2013.pdf](http://www.springsgov.com/units/communications/ColoradoSpringsFinalWaldoAAR_3April2013.pdf)
- Cohen, D., & Prusak, L. (2001). *In good company: How social capital makes companies work*. Boston, MA: Harvard Business School Press.
- Doscher, T. J. (2010). *NORTHCOM training course prepares JTF commanders for second hat*. Retrieved from U.S. Northern Command website: <http://www.northcom.mil/Newsroom/tabid/3104/Article/3149/northcom-training-course-prepares-jtf-commanders-for-second-hat.aspx>
- Federal Law Enforcement Training Center (FLETC). (2003). *Annual report FY 2003—FLETC*. Retrieved from <http://www.fletc.gov/reference/reports/annual-report/fy03-annual-report.pdf/view>
- Federal Law Enforcement Training Center (FLETC). (2005). *Annual report FY 2005—FLETC*. Retrieved from <http://www.fletc.gov/reference/reports/annual-report/fletc-annual-report.pdf/view>

- Federal Law Enforcement Training Center (FLETC). (2012). *FLETC impact report—fiscal year 2012*. Retrieved from <http://www.fletc.gov/reference/reports/FLETC%20Impact%20Report%202012%20FINAL%20508.pdf/view>
- Federal Law Enforcement Training Center (FLETC). (2013). *About FLETC*. Retrieved from <http://www.fletc.gov/about-fletc>
- Feickert, A. (2012, January 3). *The unified command plan and combatant commands: Background and issues for Congress* (Congressional Report No. R42077). Washington DC: Library of Congress Congressional Research Service.
- Gereski Jr., J. T., & Brown, C. R. (2010). Two hats are better than one: The dual-status commander in domestic operations. *Army Law*, 72.
- Government Accountability Office (GAO). (2009, September). *Homeland defense: U.S. Northern Command has a strong exercise program, but involvement of interagency partners and states can be improved* (GAO-09-849). Retrieved from <http://www.gao.gov/new.items/d09849.pdf>
- Handel, M. I. (1999, Summer). *Who is afraid of Carl von Clausewitz. A guide to the perplexed*. Newport, RI: U.S. Naval War College, Department of Strategy and Policy.
- Hicks, K. H., & Wormuth, C. E. (2009). *The future of civil affairs forces*. Washington, DC: Center for Strategic and International Studies.
- Homeland Security Act of 2002, Pub. L. No. 107–296. 116 Stat. 2135 (2002). Retrieved from: [http://www.dhs.gov/xlibrary/assets/hr\\_5005\\_enr.pdf](http://www.dhs.gov/xlibrary/assets/hr_5005_enr.pdf)
- Kapp, L. (2012). *Recruiting and retention: An overview of FY2010 and FY2011 results for active and reserve component enlisted personnel* (Congressional Report No. RL32965). Washington DC: Library of Congress Congressional Research Service.
- Joint Force Headquarters National Capital Region (JFHQ-NCR). (2013). *About Joint Force Headquarters*. Retrieved from <http://www.jtfn.northcom.mil/subpages/mission.html>
- Joint Task Force Civil Support (JTF-CS). (2103). *JTFCS fact sheet*. Retrieved from <http://www.jtfcs.northcom.mil/JTFCS.aspx>
- Joint Task Force North (JTF North). (2013). *Mission*. Retrieved from <http://www.jtfn.northcom.mil/subpages/mission.html>

- Johnson, W. S. (2002). New challenges for the unified command plan. *Joint Force Quarterly : JFQ*, (31), 62–63, 66–70. Retrieved from The Dudley Knox Library Proquest website: <http://search.proquest.com/docview/203582063?accountid=12702>
- Little, F. (2013). *Active duty civil affairs mission execution matrix*. Unpublished manuscript.
- Locher, J. R. (2001). “Has it worked? The Goldwater-Nichols Reorganization Act.” *Naval War College Review*. LIV(4), 95.
- Moore, K. (2012). *USAJFKSWCS—CA branch* [PDF file]. Retrieved from the Civil Affairs Association website: [http://civilaffairsassoc.org/presentations/CA\\_Association\\_Brief\\_ver\\_1.pdf](http://civilaffairsassoc.org/presentations/CA_Association_Brief_ver_1.pdf)
- National Commission on Terrorist Attacks upon the United States. (2004). *The 9/11 commission report: Final report of the national commission on terrorist attacks upon the United States*. New York: Norton.
- National Defense Authorization Act for Fiscal Year 2004, Pub. L. No. 108–136. Stat. 1392 (2003). Retrieved from <http://www.gpo.gov/fdsys/pkg/BILLS-112hr1540pp/pdf/BILLS-112hr1540pp.pdf>
- North American Aerospace Defense Command (NORAD). (2006). *NORAD agreement*. Retrieved from U.S. Department of State website: <http://www.state.gov/documents/organization/69727.pdf>
- North American Aerospace Defense Command (NORAD). (2013). *NORAD agreement*. Retrieved from <http://www.norad.mil/Newsroom/FactSheets/ArticleView/tabid/3991/Article/1110/norad-agreement.aspx>
- Office of the Deputy Under Secretary of Defense for Military Community and Family Policy. (2011). *2011 demographics*. Retrieved from Military One Source website: [http://www.militaryonesource.mil/12038/MOS/Reports/2011\\_Demographics\\_Report.pdf](http://www.militaryonesource.mil/12038/MOS/Reports/2011_Demographics_Report.pdf)
- Office of the Assistant Secretary of Defense for Special Operations. Low Intensity Conflict & Interdependent Capabilities. (2009). *Report to Congress on civil affairs*. Retrieved from the Civil Affairs Association website: [http://www.civilaffairsassoc.org/pdf/DoDReport\\_CA\\_HASC.pdf](http://www.civilaffairsassoc.org/pdf/DoDReport_CA_HASC.pdf)
- Secretary of the Army. (2012, September 4). *Army total force policy* (Army Directive 2012-08). Washington, DC: U.S. Army.



- Simpson, S. K. (2010). *Restructuring civil affairs for persistent engagement* (master's thesis). School of Advanced Military Studies, Ft. Leavenworth, KS. Retrieved from DTIC Online website: <http://oai.dtic.mil/oai/oai?verb=getRecord&metadataPrefix=html&identifier=ADA523223>
- Sisk, K. (2009). *House divided: The splitting of active duty civil affairs* (Master's thesis) Naval Postgraduate School, Monterey, CA. Retrieved from The Dudley Know Library website: [http://calhoun.nps.edu/public/bitstream/handle/10945/4359/09Dec\\_Sisk.pdf?sequence=1](http://calhoun.nps.edu/public/bitstream/handle/10945/4359/09Dec_Sisk.pdf?sequence=1)
- Storey, S. N. (2012). *Rebalancing Army civil affairs: The key to military governance* (master's project). U.S. Army War College, Carlisle, PA. Retrieved from DTIC Online website: <http://oai.dtic.mil/oai/oai?verb=getRecord&metadataPrefix=html&identifier=ADA562048>
- Tsang, E. W., & Zahra, S. A. (2008). Organizational unlearning. *Human Relations*, 61(10), 1435–1462.
- U.S. Army. (2005). *The Army: Field manual 1*. Washington, DC: Headquarters, Department of the Army.
- U.S. Army. (2010). *The Army capstone concept, training and doctrine pamphlet 525-3-0*. Retrieved from The U.S. Army TRADOC website: <http://www.tradoc.army.mil/tpubs/pams/tp525-3-0.pdf>
- U.S. Army. (2011). *Civil affairs operations: Field manual 3-57*. Washington, DC: Headquarters, Department of the Army.
- U.S. Army. (2012). *Special operations: Army doctrine publications 3-05*. Washington, DC: Headquarters, Department of the Army.
- U.S. Army Civil Affair and Psychological Operations Command (USACAPOC). (2010, November 22). *Status of funds yearly comparison*. Fort Bragg, NC: U.S. Army.
- U.S. Army John F. Kennedy Special Warfare Center and School (USAJFKSWCS). (2013, August 7). *The institute for military support to governance* (v. 6). Fort Bragg, NC: U.S. Army.
- U.S. Army Special Operations Command. (2006, July 24). *USASOC regulation 350-1*. Fort Bragg, NC: U.S. Army.
- U.S. Customs and Border Patrol (CBP). (2013, August 28). *Border patrol agent*. Retrieved from [http://www.cbp.gov/xp/cgov/careers/customs\\_careers/border\\_careers/bp\\_agent/](http://www.cbp.gov/xp/cgov/careers/customs_careers/border_careers/bp_agent/)

- U.S. Department of Defense. (2002, 17 April). *Special briefing on the unified command plan*. Retrieved from <http://www.defense.gov/transcripts/transcript.aspx?transcriptid=3405>
- U.S. Department of Defense. (2011a). *Capstone concept for joint operations*. Retrieved from DTIC Online website: [http://www.dtic.mil/futurejointwarfare/concepts/ccjo\\_2012.pdf](http://www.dtic.mil/futurejointwarfare/concepts/ccjo_2012.pdf)
- U.S. Department of Defense. (2011b). *National military strategy*. Retrieved from The Joint Chiefs of Staff website: [http://www.jcs.mil/content/files/2011-02/020811084800\\_2011\\_NMS\\_-\\_08\\_FEB\\_2011.pdf](http://www.jcs.mil/content/files/2011-02/020811084800_2011_NMS_-_08_FEB_2011.pdf)
- U.S. Department of Defense. (2012). *Defense strategic guidance*. Retrieved from [http://www.defense.gov/news/defense\\_strategic\\_guidance.pdf](http://www.defense.gov/news/defense_strategic_guidance.pdf)
- U.S. Department of Defense. (2013). *Civil-military operations: Joint publications 3-57*. Retrieved from DTIC Online website: [http://www.dtic.mil/doctrine/new\\_pubs/jp3\\_57.pdf](http://www.dtic.mil/doctrine/new_pubs/jp3_57.pdf)
- U.S. Department of Homeland Security (DHS). (2013). *Creation of the Department of Homeland Security*. Retrieved from <http://www.dhs.gov/creation-department-homeland-security>
- U.S. Forces Command (USFORSCOM). (2011, September 12). *Operational employment and tasking authority for the 85th civil affairs (CA) brigade (BDE)*. Fort Bragg, NC: U.S. Army.
- U.S. Northern Command (USNORTHCOM). (n.d.) *Domestic JTF commander handbook*. Retrieved from the Naval Postgraduate School Center for Homeland Defense and Security, Homeland Security Digital Library website: <http://www.hsdl.org/?view&did=710068>
- U.S. Northern Command (USNORTHCOM). (2012, December 31). *A short history of United States Northern Command*. Retrieved from <http://www.northcom.mil/Portals/28/Documents/Supporting%20documents/Historical/NORTHCOM%20History.pdf>.
- U.S. Northern Command's Public Affairs Office. (2012). *Federal partners continue to support response efforts combating western fires*. Retrieved from <http://www.northcom.mil/DesktopModules/DigArticle/Print.aspx?PortalId=28&ModuleId=8513&Article=3024>
- U.S. Secret Service (USSS). (2013, August 28). *Training: James J. Rowley training center*. Retrieved from [http://www.secretservice.gov/join/training\\_rowley.shtml](http://www.secretservice.gov/join/training_rowley.shtml)
- U.S. Special Operations Command. (2011). *Proposal to transfer proponent for civil affairs*. (No. 4.1).

- Van Roosen, H. (2009). *Implications of the 2006 reassignment of U.S. Army civil affairs*. (Master's thesis). U.S. Army War College, Carlisle, PA. Retrieved from DTIC Online website: <http://oai.dtic.mil/oai/oai?verb=getRecord&metadataPrefix=html&identifier=ADA494806>
- White, J. (2008, October 17). *Civil affairs in Vietnam*. Washington, DC: Center for Strategic and International Studies.
- White House. (2010). *National security strategy*. Retrieved from [http://www.whitehouse.gov/sites/default/files/rss\\_viewer/national\\_security\\_strategy.pdf](http://www.whitehouse.gov/sites/default/files/rss_viewer/national_security_strategy.pdf)
- Wren, D. A., & Bedeian, A. G. (1994). *The evolution of management thought*. New York: John Wiley.
- Yates, L. A. (2006). *The U.S. military's experience in stability operations, 1789–2005*. (Occasional Paper 15 No. 15). Fort Leavenworth, KS: Combat Studies Institute Press.

## **INITIAL DISTRIBUTION LIST**

1. Defense Technical Information Center  
Ft. Belvoir, Virginia
2. Dudley Knox Library  
Naval Postgraduate School  
Monterey, California