



Calhoun: The NPS Institutional Archive

Theses and Dissertations

Thesis Collection

1992-09

Analysis of simulation tools for the study of
advanced marine power systems

Brochard, Paul Eugene

Monterey, California. Naval Postgraduate School

<http://hdl.handle.net/10945/38568>



Calhoun is a project of the Dudley Knox Library at NPS, furthering the precepts and goals of open government and government transparency. All information contained herein has been approved for release by the NPS Public Affairs Officer.

Dudley Knox Library / Naval Postgraduate School
411 Dyer Road / 1 University Circle
Monterey, California USA 93943

<http://www.nps.edu/library>

2

NAVAL POSTGRADUATE SCHOOL

Monterey, California

AD-A257 338

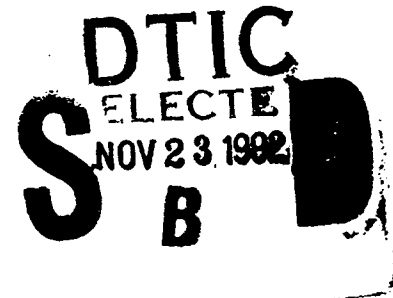

THESIS

ANALYSIS OF SIMULATION TOOLS FOR THE STUDY OF
ADVANCED MARINE POWER SYSTEMS

by

Paul Eugene Brochard

September 1992

Thesis Advisor:

Stephen M. Williams

Approved for public release; distribution is unlimited

92-29924

REPORT DOCUMENTATION PAGE			
1a. REPORT SECURITY CLASSIFICATION UNCLASSIFIED		1b. RESTRICTIVE MARKINGS	
2a. SECURITY CLASSIFICATION AUTHORITY		3. DISTRIBUTION/AVAILABILITY OF REPORT Approved for public release; distribution is unlimited.	
2b. DECLASSIFICATION/DOWNGRADING SCHEDULE			
4. PERFORMING ORGANIZATION REPORT NUMBER(S)		5. MONITORING ORGANIZATION REPORT NUMBER(S)	
6a. NAME OF PERFORMING ORGANIZATION Naval Postgraduate School	6b. OFFICE SYMBOL (if applicable) ECE	7a. NAME OF MONITORING ORGANIZATION Naval Postgraduate School	
6c. ADDRESS (City, State, and ZIP Code) Monterey, CA 93943-5000		7b. ADDRESS (City, State, and ZIP Code) Monterey, CA 93943-5000	
8a. NAME OF FUNDING/SPONSORING ORGANIZATION	8b. OFFICE SYMBOL (if applicable)	9. PROCUREMENT INSTRUMENT IDENTIFICATION NUMBER	
8c. ADDRESS (City, State, and ZIP Code)		10. SOURCE OF FUNDING NUMBERS	
		Program Element No.	Project No.
		Task No.	Work Unit Accession Number
11. TITLE (Include Security Classification) ANALYSIS OF SIMULATION TOOLS FOR THE STUDY OF ADVANCED MARINE POWER SYSTEMS			
12. PERSONAL AUTHOR(S) Paul Eugene Brochard			
13a. TYPE OF REPORT Master's Thesis	13b. TIME COVERED From To	14. DATE OF REPORT (year, month, day) September 1992	15. PAGE COUNT 118
16. SUPPLEMENTARY NOTATION The views expressed in this thesis are those of the author and do not reflect the official policy or position of the Department of Defense or the U.S. Government.			
17. COSATI CODES		18. SUBJECT TERMS (continue on reverse if necessary and identify by block number)	
FIELD	GROUP	Power systems modelling, Advanced Marine Power Systems, Homotopy, Waveform Methods, Newton-Raphson, Power Systems Simulation, WAVESIM, Simulation program evaluation, Computer program evaluation	
19. ABSTRACT (continue on reverse if necessary and identify by block number)			
<p>The United States Navy is at a crossroads in the design of ship's engineering plants. Advances in solid-state power electronics combined with a shift to gas turbine powered propulsion and electric plants has placed renewed emphasis on developing advanced power systems.</p> <p>These advanced power systems may combine the prime movers associated with propulsion and electric power generation into an integrated system. The development of advanced electric distribution systems and propulsion derived ships service (PDSS) power systems are interim steps towards the goal of an integrated system.</p> <p>Advances in the design of ships power systems, whether revolutionary or evolutionary, will require extensive testing and simulation. This thesis will develop a basis with which to judge various simulation tools. It will then evaluate a simulation program developed for the Navy by the Massachusetts Institute of Technology.</p>			
20. DISTRIBUTION/AVAILABILITY OF ABSTRACT <input checked="" type="checkbox"/> UNCLASSIFIED/UNLIMITED <input type="checkbox"/> SAME AS REPORT <input type="checkbox"/> DTIC USERS		21. ABSTRACT SECURITY CLASSIFICATION UNCLASSIFIED	
22a. NAME OF RESPONSIBLE INDIVIDUAL Williams, Stephen M.		22b. TELEPHONE (Include Area code) 408-646-3001	22c. OFFICE SYMBOL EC/WL

Approved for public release; distribution is unlimited.

Analysis of Simulation Tools for the Study of Advanced Marine Power Systems

by

**Paul Eugene Brochard
Lieutenant, United States Navy
B.S., United States Naval Academy, 1986**

Submitted in partial fulfillment
of the requirements for the degree of

MASTER OF SCIENCE IN ELECTRICAL ENGINEERING

from the

**NAVAL POSTGRADUATE SCHOOL
September 1992**

Author:



Paul Eugene Brochard

Approved by:



Stephen M. Williams, Thesis Advisor

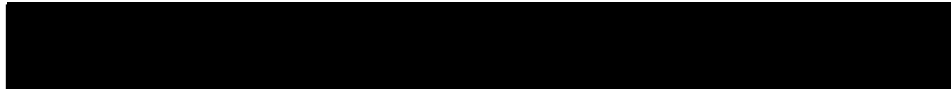

Monique P. Fargues, Second Reader



Michael A. Morgan, Chairman

Department of Electrical and Computer Engineering

ABSTRACT

The United States Navy is at a crossroads in the design of ship's engineering plants. Advances in solid-state power electronics combined with a shift to gas turbine powered propulsion and electric plants has placed renewed emphasis on developing advanced power systems.

These advanced power systems may combine the prime movers associated with propulsion and electric power generation into an integrated system. The development of advanced electric distribution systems and propulsion derived ships service (PDSS) power systems are interim steps toward the goal of an integrated system.

Advances in the design of ships power systems, whether revolutionary or evolutionary, will require extensive testing and simulation. This thesis will develop a basis with which to judge various simulation tools. It will then evaluate a simulation program developed for the Navy by the Massachusetts Institute of Technology.

DTIC QUALITY INSPECTED 4

Accession For	
NTIS GRA&I	<input checked="" type="checkbox"/>
DTIC TAB	<input type="checkbox"/>
Unannounced	<input type="checkbox"/>
Justification	
By _____	
Distribution/	
Availability Codes	
Dist	Avail and/or Special
A-1	

TABLE OF CONTENTS

I.	INTRODUCTION	1
A.	BACKGROUND	1
B.	OBJECTIVES	1
C.	SUMMARY OF THESIS	2
	1. A View of Present and Future Naval Power Systems.	2
	2. Required Software Capabilities.	2
	3. Detailed Models Necessary to Simulate a Ships Power System.	3
	4. Detailed Description of WAVESIM	3
	5. Analysis and Testing of WAVESIM	3
	6. Conclusions	3
II.	A VIEW OF THE PRESENT AND FUTURE OF NAVAL POWER SYSTEMS	5
A.	PRESENT DESIGN OF NAVAL POWER PLANTS	5
B.	ANTICIPATED DEVELOPMENTS IN SHIPS POWER SYSTEMS	7
	1. Advanced distribution systems	7
	a. Energy Storage	10

b.	Reconfiguration Techniques	10
c.	Power Conditioning	11
d.	Embedded Intelligence	11
e.	Zonal Distribution	12
2.	Propulsion Derived Ship's Service	12
C.	MODELLING REQUIREMENTS NECESSARY TO SUPPORT ANTICIPATED DEVELOPMENTS	16
D.	CURRENT RESEARCH IN SUPPORT OF ANTICIPATED DEVELOPMENTS	20
1.	Machinery Simulation Laboratory at David Taylor Research Center	20
2.	Hybrid Analog/Digital Computer Simulations at Purdue University	20
3.	Digital Computer Modelling	21
a.	Purdue University	21
b.	Massachusetts Institute of Technology	22
III	REQUIRED SOFTWARE CAPABILITIES	23
A.	SYSTEM AND COMPONENT LEVEL MODELLING ENVIRONMENT	23
B.	ROBUSTNESS WHEN SIMULATING NON-LINEAR AND RAPID SWITCHING TOPOLOGIES	24
C.	CORRECTNESS OF SOLUTION	24
D.	SOFTWARE DOMAIN	24
E.	IMPLEMENTATION OPTIONS	25
F.	EASE OF USE	25

G.	SOFTWARE SPEED VERSUS SYSTEM COMPLEXITY	26
H.	CONTINUED SUPPORT	26
IV.	DETAILED MODELS NECESSARY TO SIMULATE SHIPS POWER SYSTEMS	27
A.	MACHINERY SIMULATION LAB MODELS	27
1.	Speed Regulator	27
2.	Current Regulator	30
3.	DC Motor Model	30
4.	Three Phase Synchronous Generator Model	33
5.	Voltage Regulator Model	35
6.	Resistive-Inductive Load	37
B.	ADDITIONAL MODELS FOR SHIPBOARD ELECTRICAL DISTRIBUTION SYSTEM	37
1.	Induction Motor Model	39
2.	Prime Movers	41
3.	Static Excitation System	43
4.	DC System	43
5.	Solid-state Power Converters	43
V	DETAILED DESCRIPTION OF WAVESIM	48
A.	WHAT IS WAVESIM	48
1.	WAVESIM Source Code	49
2.	Waveform Operators	49
3.	Definition Files	50
4.	Device Files	51

5.	Input Files	52
	a. Debug	52
	b. Default	53
	c. Device	54
	(1) Terminal	54
	(2) Parameter	54
	(3) States	55
	d. Include	55
	e. Node	55
	f. Time	56
	g. Plot	57
B.	SOLUTION METHOD USED IN WAVESIM	57
	1. Device Modelling	57
	2. Building a System of Equations and Block Reduction	62
	3. Waveform Representation of Interface Variables	65
	4. Newton-Raphson Solution to Systems of Algebraic Equations	68
C.	WAVESIM ALGORITHM	72
VI	ANALYSIS AND TESTING OF WAVESIM	76
	A. STUDY APPROACH	76
	B. MODELING THE TURBINE EMULATOR	77
	1. Speed Regulator	77
	2. Current Regulator	82

3.	DC Motor	86
4.	Combined Elements of the Turbine Emulator .	89
5.	Voltage Regulator	89
6.	Conclusions on Modelling the Turbine Emulator	93
C.	EVALUATION OF WAVESIM VERSUS THE METRICS IN CHAPTER THREE	95
1.	System and Component Level Modelling Environment	95
2.	Robustness When Simulating Non-Linear or Rapid Switching Topologies	96
3.	Correctness of Solution	96
4.	Software Domain	96
5.	Implementation Options	97
6.	Ease of Use	97
7.	Software Speed Versus System Complexity . .	98
8.	Continued Support	98
VIII	CONCLUSIONS	100
A.	NEED	100
B.	ANALYSIS OF WAVESIM	101
C.	FUTURE WORK	101
1.	Wavesim	101
2.	Other programs	101
	LIST OF REFERENCES	103

INITIAL DISTRIBUTION LIST 106

I. INTRODUCTION

A. BACKGROUND

The United States Navy is at a crossroads in the design of ship's engineering plants. Advances in solid-state power electronics combined with a shift to gas turbine powered propulsion and electric plants has placed renewed emphasis on developing advanced power systems.

These advanced power systems may combine the prime movers associated with propulsion and electric power generation into an integrated system. The development of advanced electric distribution systems and propulsion derived ships service (PDSS) power systems are interim steps towards this goal. The end result may be an Integrated Electric Drive (IED) which is characterized by a central electric generating plant providing electricity both to synchronous propulsion motors and for ships service use. The driving factors in this program are reduced lifetime costs, weight savings, and ship quieting.

B. OBJECTIVES

Advances in the design of ship's power systems, whether revolutionary or evolutionary, will require extensive testing and simulation. The required simulations must be capable of modeling both high speed electrical transients and relatively low speed mechanical transients. Further, they must be able

to effectively model fast switching power converters that are an essential part of most advanced power systems. This thesis will develop a basis with which to judge various simulation tools. Specifically it will:

- define a baseline system to be simulated for use in judging the efficacy of various programs
- list a set of evaluation metrics
- detail the minimum operating conditions to be modelled
- test a simulation program developed for David Taylor Research Center (DTRC)

C. SUMMARY OF THESIS

1. A View of Present and Future Naval Power Systems.

This section presents the basics of current naval power systems and will detail the evolutionary steps currently envisioned by Naval Sea Systems Command Code 05Z (NAVSEA 05Z), the Advanced Ship's Machinery Systems Project Office, and David Taylor Research Center towards the goal of an IED system.

2. Required Software Capabilities.

The required capabilities of a software package are compiled as specified in a variety of sources. Desirable capabilities are also discussed.

3. Detailed Models Necessary to Simulate a Ships Power System.

This chapter provides detail on specific models developed for the simulation of ships power systems. Mathematical models, block diagrams, or schematics are provided.

4. Detailed Description of WAVESIM

The computer program WAVESIM developed at the Massachusetts Institute of Technology (MIT) by LT Norbert Doerry is discussed [1]. The components of the simulation program are described and the solution methods used by Doerry to address the problems of modelling marine power systems are summarized.

5. Analysis and Testing of WAVESIM

This chapter presents the results of a number of simulations run using WAVESIM. It then presents the results of an evaluation of WAVESIM using the metrics developed in Chapter III. This chapter is not a technical validation of WAVESIM.

6. Conclusions

This chapter makes a statement concerning the need for a program suitable for simulating advanced marine power

systems. It then identifies future work required if WAVESIM is to fill that need. Lastly it identifies other simulation packages that might be useful for this type of study.

II. A VIEW OF THE PRESENT AND FUTURE OF NAVAL POWER SYSTEMS

The current design of naval power plants is similar to that used for many decades. Whether a ship is powered by steam turbines, gas turbines, or diesel engines the prime movers associated with propulsion and power generation are separate. Relatively unsophisticated local control is used to operate the electric power plant. Recent advances in power electronics and control of power systems may allow significant advances to be made in this area culminating in an IED System with an advanced distribution system.

A. PRESENT DESIGN OF NAVAL POWER PLANTS

Design of naval power plants emphasizes survivability and weight reduction. Ships power distribution systems are three phase and ungrounded operating at a nominal 450 volts. Electricity is typically generated by two or three synchronous generators that may operate in parallel or isosynchronously. On conventional (non nuclear) ships, the generators may be driven by steam turbines, gas turbine engines, or diesel engines. Table I lists the electrical plant characteristics of a selection of conventionally powered US combatants.

TABLE I ELECTRIC PLANT CHARACTERISTICS OF SELECTED US SHIPS [1:p.32]			
Ship Class	Class Name	Generation	Prime Movers
CG 16	Lehey	4 X 1500 KW 1 X 750 KW 1 X 300 KW	Steam Turbine Gas Turbine Diesel
FF 1052	Knox	3 X 750 KW 1 X 750 KW	Steam Turbine Diesel
FFG 7	Oliver Hazard Perry	4 X 1000 KW	Diesel
DD 963	Spruance	4 X 2000 KW	Gas Turbine
CG 47	Ticonderoga	3 X 2500 KW	Gas Turbine
DDG 51	Arleigh Burke	3 X 3000 KW	Gas Turbine

Loads are categorized as either vital or non-vital. Vital equipment has at least one, possibly two, redundant sources of power. Equipment essential to ships safety is considered vital including:

- Steering motors
- Auxiliary equipment supporting propulsion and power generation
- Damage control equipment such as fire pumps and interior communications
- Lighting
- Communications and navigation equipment
- Weapons systems

- Machinery space ventilation

Switching of vital equipment to alternate power sources is conducted either through automatic bus transfer (ABT) switches or manual bus transfer (MBT) switches. Further, the type of controller found on vital equipment determines whether a given piece of equipment will restart automatically when power is restored as is the case for a low voltage release (LVR) controller, or must be manually restarted as is the case for a low voltage protection (LVP) controller. Figure 1 shows the generator and switchgear configuration for a typical steam propulsion ship [2]. Figure 2 shows the generator and switchgear configuration for a modern gas turbine powered ship [3].

B. ANTICIPATED DEVELOPMENTS IN SHIPS POWER SYSTEMS

1. Advanced distribution systems

As a first step towards an IED system a computer controlled advanced distribution system is envisioned. This system would have the ultimate goal of automating "monitoring and control decision making on the naval power systems to the greatest extent possible [4]". This would be accomplished using state of the art microcomputer control combined with power electronics. Ideally the system developed will have the following characteristics [5]:

- solid-state bus transfer

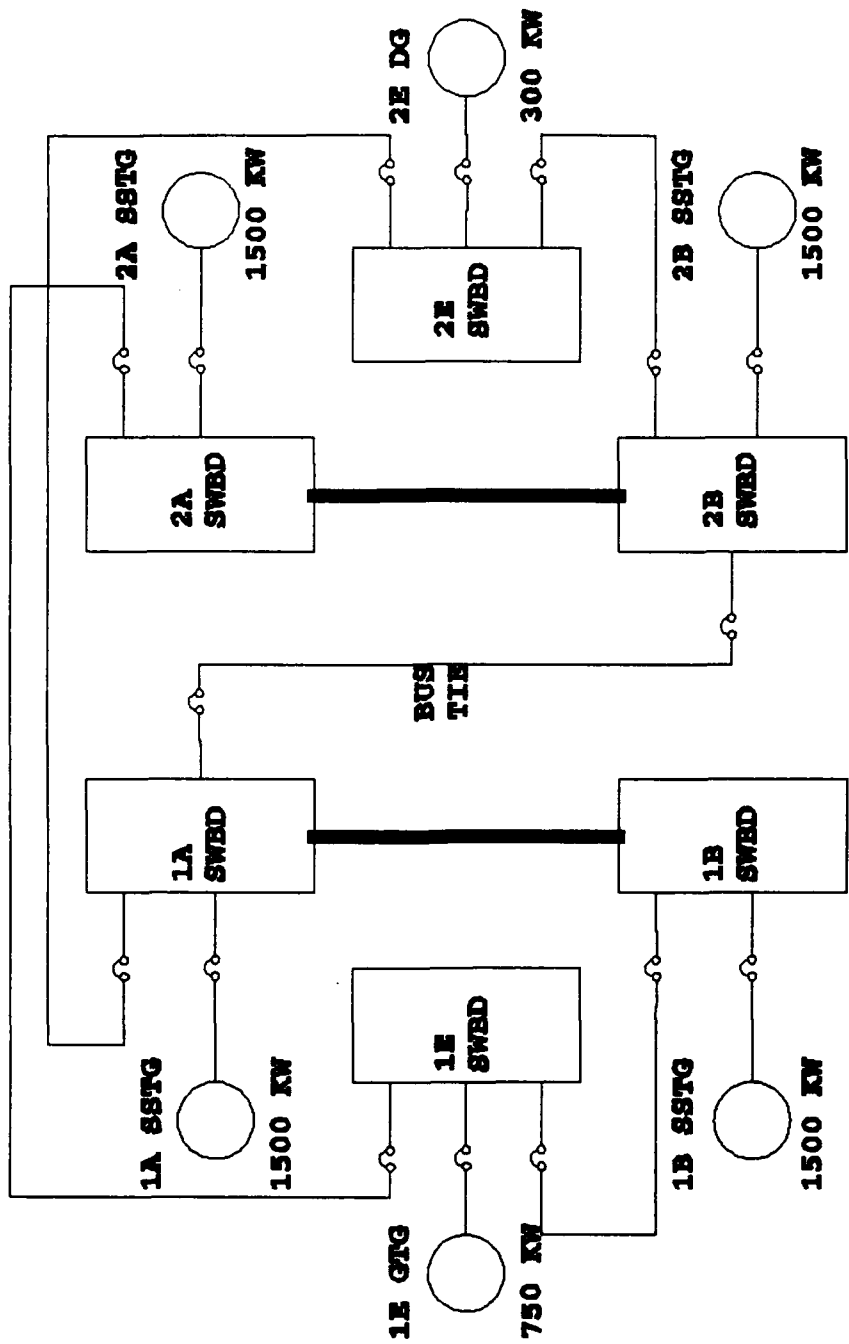

Figure 1 Generator and switchgear arrangement for a steam plant [2]

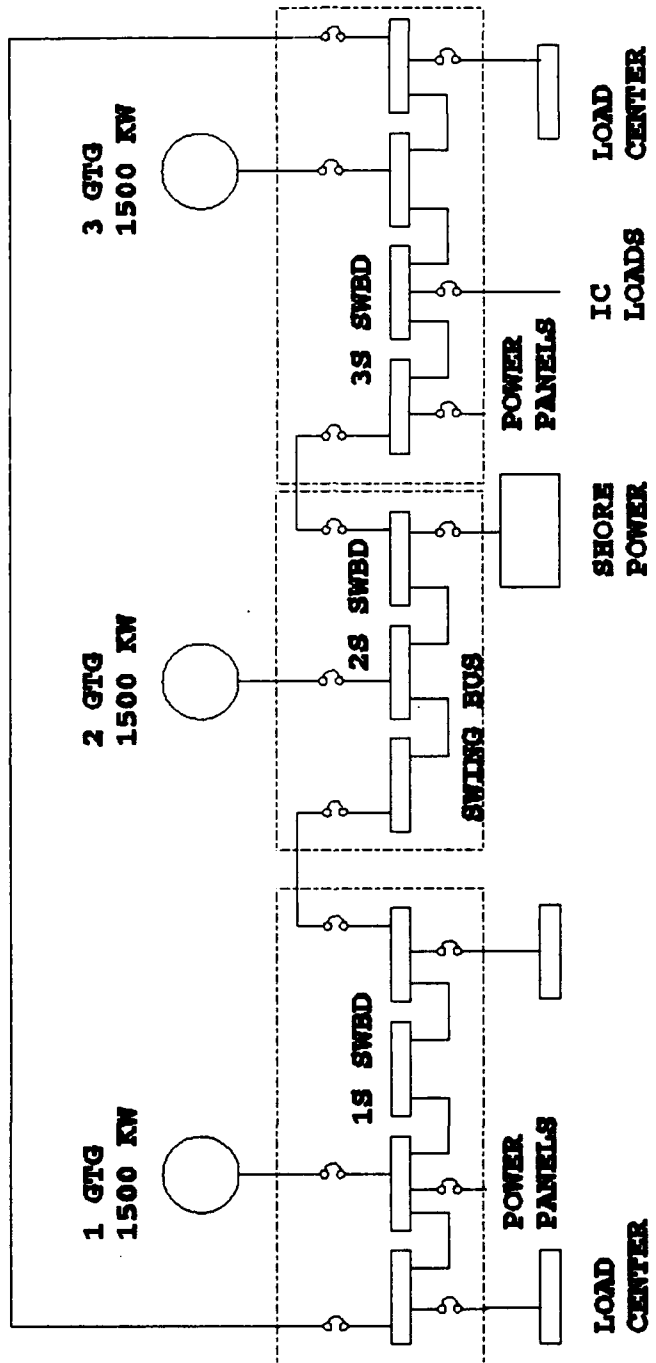

Figure 2 Generator and switchgear arrangement for a gas turbine plant [3]

- solid-state circuit breakers
- energy storage
- reconfiguration techniques
- embedded intelligence

A number of the points listed above need to be expanded upon.

a. *Energy Storage*

The number one design issue for a combatant power system is continuity. A ship must maintain its ability to fight despite potential damage suffered in battle. As discussed in section II.A., equipment vital to a ship's safety and combat effectiveness is supplied both normal and alternate sources of power. However, for some sensitive equipment, even the brief time required to shift from normal to alternate power sources may be damaging. Local sources such as uninterruptable power supplies, UPS's, are needed during the time required to switch to an alternate power source. This capability is known as fight through.

b. *Reconfiguration Techniques*

Often there are several routes through which power may be supplied to a vital piece of equipment. A system that automatically reconfigures the distribution system following a casualty or damage might save a ship in battle. This is a system level consideration as compared to the component level solution based on ABT's and MBT's.

c. Power Conditioning

As stated in the Chapter I section A, advances in power electronics are a driving factor in the development of advanced power systems. The development of high power devices and advances in the control of solid state converters has resulted in a larger proportion of the total electrical load being dedicated to solid state converters. This in turn has increased problems due to the harmonic frequencies generated by these devices. This problem will most likely grow worse over time. As will be shown, a cornerstone of the IED system is the use of very high power solid state switching converters.

Partial relief from this problem may result from improved algorithms for controlling these converters. It is likely, however, that active power conditioning will also be required to ensure proper operation of equipment sensitive to harmonic disturbances.

d. Embedded Intelligence

The use of intelligent control systems using state of the art monitoring and data acquisition may allow active load control and configuration-based protection to be implemented. Active load control will ensure that a system is not overloaded by having too many devices starting during a given time period (for example following a casualty or when configuring for battle) or during rapid speed changes which

might stress an IED system. The current solution to these problems is over design of the system to account for startup transients and the use of LVP controllers as discussed previously to ensure time separation in restarting equipment following a casualty.

e. Zonal Distribution

Figure 3 shows the simplified oneline diagrams of the 60 Hz distribution systems for a Navy guided missile destroyer [3]. The top diagram shows the current design which matches Fig. 2. The bottom diagram shows the proposed zonal distribution system. Among the benefits of this new proposed system are reduced bulkhead penetrations resulting in greater watertight integrity between zones and elimination of over 19000 feet of cable resulting in a weight reduction of over 31 tons [3].

2. Propulsion Derived Ship's Service

By definition an IED ship will require propulsion derived ship's service (PDSS). PDSS describes a system in which ships service electrical power is generated, at least in part, from a ships main engines. Energy may be transferred from the propulsion system either through electrical or mechanical means. Some version of PDSS with mechanical drive will most likely be an interim step towards a complete IED system. Figures 4 and 5 show four potential methods of implementing PDSS [6].

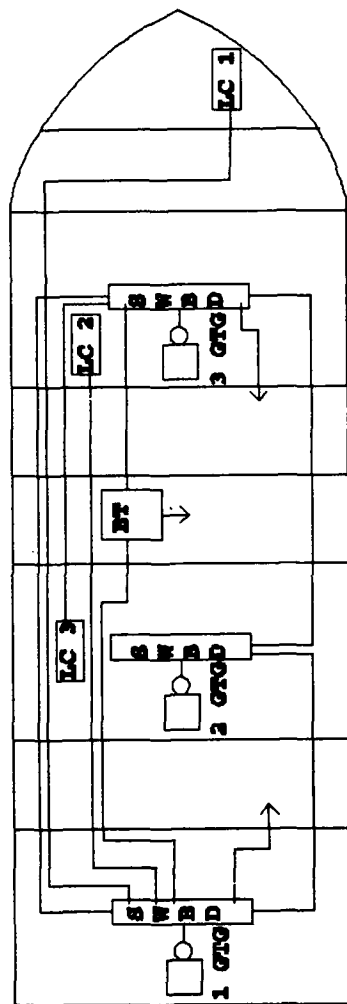

Present 60 Hz Distribution System

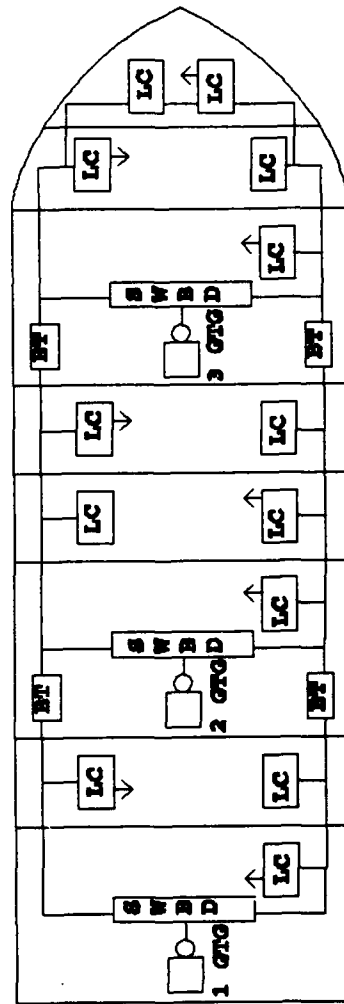

Proposed advanced 60 Hz zonal distribution system

Figure 3 Oneline diagram of a DDG 60 Hz distribution system [3]

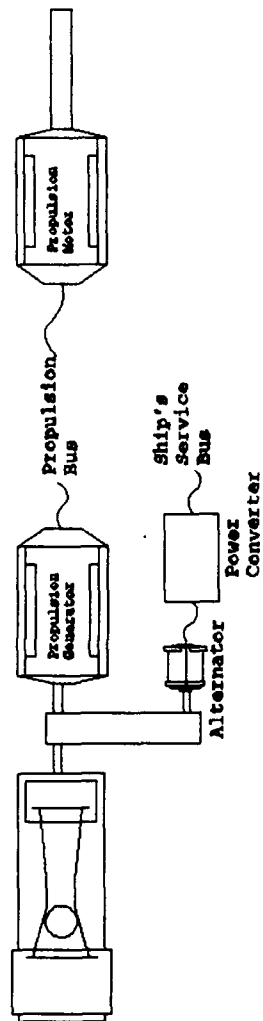

Electric Drive Propulsion

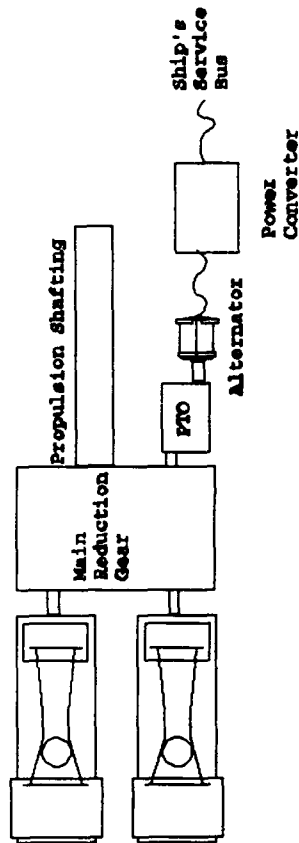

Mechanical Drive Propulsion

Figure 4 Two variations of propulsion derived ship's service power

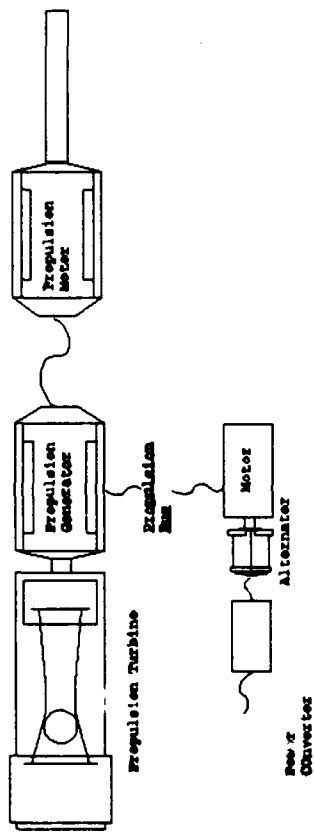

Motor Generator Set Approach

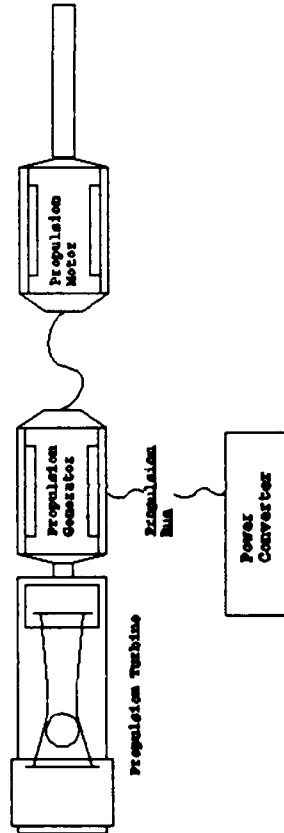

All Solid State Approach

Figure 5 Two additional variations of propulsion derived ship's service

Each of the four methods shown requires a power converter prior to the ships service bus. In a conventional gas turbine power system the gas turbine generator (GTG) is speed regulated to maintain constant frequency. Propulsion turbine speed is not constant therefore a variable speed constant frequency (VSCF) system must be implemented. Figure 6 is a block diagram of a PDSS VSCF generating system [6]. Figure 7 is a 100 KW cycloconverter tested as part of a VSCF hardware model [6]. A similar topology might be appropriate for shipboard use.

There are several benefits inherent to PDSS including [8]:

- Fuel savings due to incremental efficiency of propulsion turbines over smaller turbine generator sets
- Increased mission range due to decreased fuel consumption
- Increased space due to removal of turbine generators and associated auxiliary equipment
- Arrangement flexibility due to a more compact engineering plant
- Enhanced survivability due to removal of turbine generator sets
- Reduced maintenance due to less turbine equipment

C. MODELLING REQUIREMENTS NECESSARY TO SUPPORT ANTICIPATED DEVELOPMENTS

As previously stated, advances in the design of ship's power systems require extensive testing and simulation to

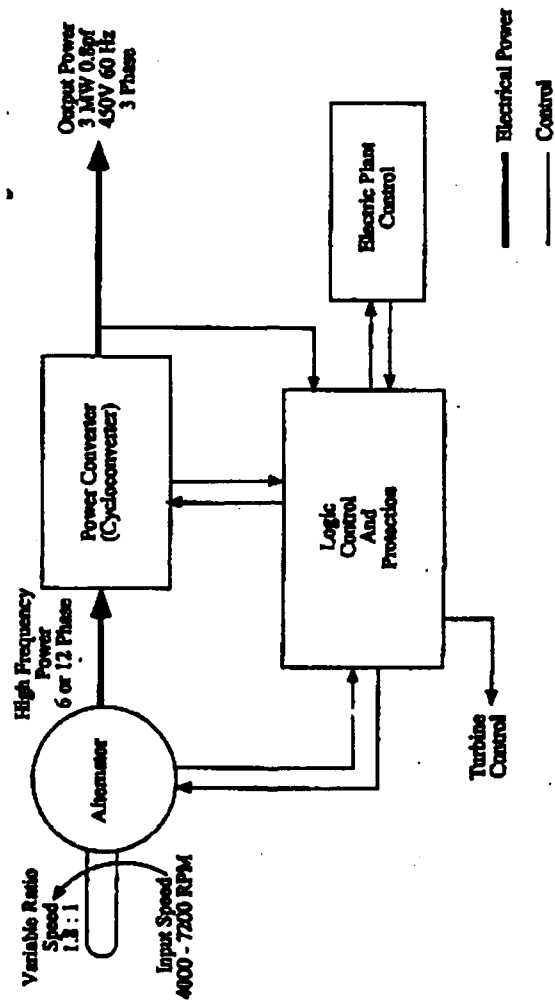

Figure 6 Block diagram for propulsion derived ship's service using variable speed constant frequency techniques [6]

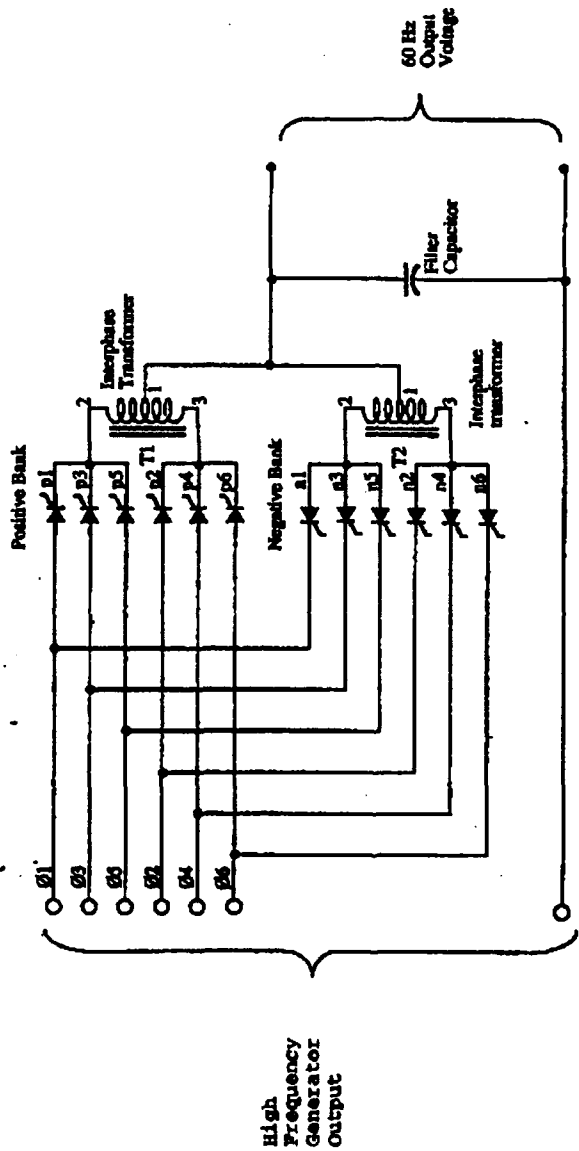

Figure 7 100 Kw cycloconverter basic power circuit [6]

characterize and validate system and component performance. These simulations must be able to accurately depict system performance under all operating conditions including normal and casualty situations. Some examples of the operating conditions to be modelled are:

- Balanced and unbalanced electrical faults
- Dynamic breaking in an IED implementation
- Overspeed conditions
- Protective device trips
- Abrupt speed changes or shaft reversal (crash back)

Two levels of detail are of interest: full order (or detailed) and reduced order simulations. Applications of full order simulations include:

- waveform level studies
- support of component development
- power continuity studies
- verification of reduced order models

These simulations must be fast, yet they must retain electrical transient behavior. Simulations requiring less detail may use reduced order modelling which provides the envelope of the system performance. This approach is suited to simulating electro-mechanical transients or to simulating electrical systems where waveform level detail is not required. Applications of reduced order modelling include:

- dynamic stability
- control design
- balanced fault studies

D. CURRENT RESEARCH IN SUPPORT OF ANTICIPATED DEVELOPMENTS

1. Machinery Simulation Laboratory at David Taylor Research Center

The machinery simulation laboratory (MSL) at DTRC is intended to provide a scale model to test new power technology for shipboard use. While we will introduce the MSL at this time it is described in detail in the following chapter. The laboratory consists of a turbine emulator driving a 3 phase synchronous generator. The turbine emulator is composed of a DC motor with solid state armature supply that may be operated in either current regulated or speed regulated modes. A compliant shaft coupling is used between the DC motor and the synchronous generator which allows torque to be monitored. Transmitted torque is then compared to the simulated response of the desired prime mover. Among the uses of the MSL is the validation of computer models developed for the simulation of shipboard power systems. [8]

2. Hybrid Analog/Digital Computer Simulations at Purdue University

Purdue University has designed and extensively used a computer based on a combination of analog and digital technology [8],[9]. This system has been used to conduct

system studies for the Navy. Among the benefits of this approach is speed. The speed of the simulation is independent of the system complexity due to the use of parallel integration. Purely digital techniques use serial integration which creates a direct link between solution speed and system complexity. The drawbacks of an analog simulation include high overhead in time and manpower setting up a simulation and a limitation on the size of the system to be modelled based on equipment available. [6]

3. Digital Computer Modelling

a. *Purdue University*

Other work at Purdue University consists of using the commercial package Advanced Computer Simulation Language (ACSL) to model systems, subsystems, and components related to ships power systems. This effort uses strictly digital simulation techniques.

Further work at Purdue is in the area of reduced order modelling. Ship's power systems are "stiff", that is various time constants within the system are widely separated. The small time step required for the numerical solution of the fast transients makes it infeasible to conduct the long simulations required to model the mechanical transients associated with an IED system. If one can neglect the fast transients then the solution becomes much faster. [6]

b. Massachusetts Institute of Technology

The Massachusetts Institute of Technology has addressed the problems associated with modelling ships power systems with an ambitious project to develop a new software package, WAVESIM. WAVESIM addresses the stiffness problem associated with ships power systems through the use of waveform representation of system variables. The use of waveform techniques allows much larger time steps than do traditional integration schemes. A detailed explanation of the methods employed by WAVESIM is given in Chapter

V. [1] [4] [12] [13]

III. REQUIRED SOFTWARE CAPABILITIES

An evaluation requires a set of metrics. This paper proposes a set of metrics to be used for the evaluation of detailed waveform analysis tools used to simulate shipboard power systems. General requirements for a tool of this nature are given by [1], [4], and [13]. The following paragraphs combine and extend the requirements set forth in [1], [4], and [12].

A. SYSTEM AND COMPONENT LEVEL MODELLING ENVIRONMENT

The proposed system simulator must be modular, allowing for the interconnection of various component models into widely varying system topologies. The ability to model highly non-linear components and components that introduce discontinuities to the system is essential.

Available component models should include at a minimum: prime movers, synchronous, induction, and dc machines; solid state converters; and various passive load representations.

The simulation should be intuitive in that both component models and system models should reflect their physical counterparts.

Lastly, it is essential that the user be able to add component models. Component model addition should involve a

minimum of effort in the transition from physics to computer code.

B. ROBUSTNESS WHEN SIMULATING NON-LINEAR AND RAPID SWITCHING TOPOLOGIES

The simulation must be able converge to the solution representing the actual operation of the component devices. A simple example is to disallow currents from existing in the reverse bias direction of a diode. Models must be capable of detailed representation of transient behavior during and following topology changes due to events such as solid state switching, circuit breaker closing, faults, or equipment start-up/shut down.

C. CORRECTNESS OF SOLUTION

The simulation must accurately depict the characteristics of interest in support of detailed waveform analysis. Sources of numerical error must be addressed, quantified and bounded. Some form of feedback as to the reliability of the solution must be provided by the simulation. Adequate validation must be performed against real world data or accepted similar simulations.

D. SOFTWARE DOMAIN

A means of importing field test data should be provided. The ability to plot imported data superimposed on simulation results provides a valuable tool. Further, a means of using

imported field test data to drive component models is desirable. Models should be developed such that various control parameters are easily changed to aid in control system synthesis.

E. IMPLEMENTATION OPTIONS

The simulation must be fully portable. The chosen programming language, algorithms, and documentation methods should be written to provide long term maintainability. Graphics output presents particular problems with portability. One way to preclude problems in this area is to ensure graphics output is handled by a separate and isolated subprogram. Data input and output options should include both interactive and file modes.

F. EASE OF USE

The simulation should be user friendly. Both interactive and file input modes should be intuitive. Display of simulation results should be flexible. The capability to easily plot potentials with respect to a reference or across devices, to plot flow variables and to manipulate data (shifting, multiplication, addition, subtraction, integration, and differentiation) are required. Simulation results, in the form of time series data, should be saved to a data file in standard (ASCII) format. The graphics subprogram should be able to present previously saved data from these files.

G. SOFTWARE SPEED VERSUS SYSTEM COMPLEXITY

Due to the potential complexity of the systems to be modeled, the simulation must be fast while retaining transient behavior. For specialized studies, reduced order models should be implemented to enhance simulation speed while maintaining accurate representation of the characteristics of interest.

H. CONTINUED SUPPORT

A program applied to ship power system design and analysis will be used in arriving at decisions involving millions of dollars in government expenditures and may be used over a period of many years. It is essential, therefore, that such a program carry with it a long term commitment of support. Essentially this requires a package to be commercially supported or supported by an organization equipped to make this kind of commitment.

IV. DETAILED MODELS NECESSARY TO SIMULATE SHIPS POWER SYSTEMS

The required models are placed into two groups. Those models required to simulate the MSL are given first. These models will be used to demonstrate WAVESIM. The second group of models are derived from studies conducted by P.C. Krause for use in work conducted for the Navy by Purdue University and PC Krause and Associates [9]. While the models included are not all-inclusive they provide a representative sample of the type of models that are required. The only models covered in detail are those used in the testing of WAVESIM.

A. MACHINERY SIMULATION LAB MODELS

A block diagram of the machinery simulation lab at David Taylor Research Center is given in Fig. 8. This lab consists of a DC motor which operates in either a speed regulated or current regulated mode driving a synchronous 3 phase generator. The DC motor, current regulator, and speed regulator make up the turbine emulator which provides dynamic emulation of various gas turbine and diesel prime movers. [8]

1. Speed Regulator

The block diagram for the speed regulator is given in Fig. 9. In this model a reference speed, w_{ref} , is compared to the actual motor speed, w_m , resulting in the output of a reference current, i_{ref} , which goes to the current regulator.

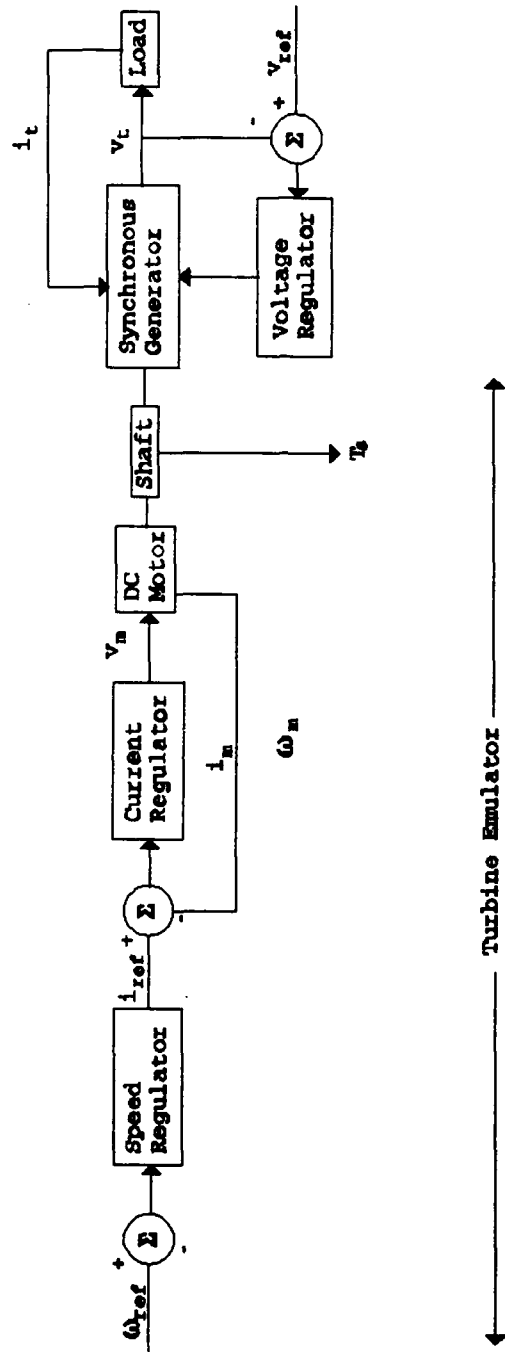

Figure 8 Block Diagram of the machinery simulation lab at David Taylor Research Center [8]

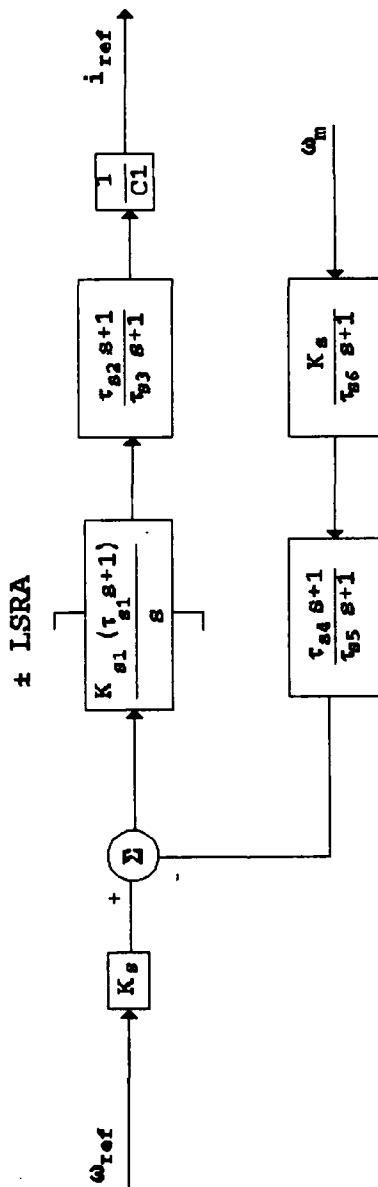

Figure 9 Block diagram for machinery simulation lab speed regulator [8]

When used to emulate a prime mover, the reference speed is generated by a comparison of the transmitted shaft torque between the DC motor and synchronous generator to simulate the response of the prime mover of interest.

The variable LSRA in Fig. 9 represents the amplifier limits using a non wind-up limiter as described in [13]. This limiter is modelled simply as a minimum/maximum filter passing the actual output value of a block if the output is within the limits and passing either the minimum or maximum value of the filter if the output of the block is outside these limits.

2. Current Regulator

The current regulator controls the motor current by comparing the reference current provided by the speed regulator, i_{ref} , to the motor current, i_m . Figure 10 is a block diagram of the current regulator. Note the use of the non-windup limiter once again. The output of the current regulator is the DC motor armature voltage, v_m .

3. DC Motor Model

Figure 11 shows a simple first order model chosen to model the DC motor. A more detailed model would include core losses, windage and friction losses as detailed in [14]. The error generated by this approximation as reported in [8] is on the order of 3.5 percent at rated conditions.

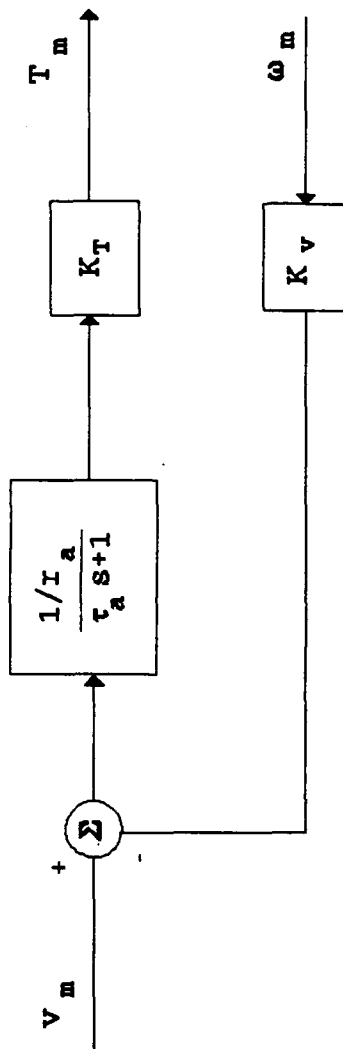

Figure 11 Block diagram of DC motor of the machinery simulation lab [8]

4. Three Phase Synchronous Generator Model

The synchronous generator model used to illustrate the capabilities of WAVESIM is derived in [15]. This model consists of seven first order differential equations given in the rotor reference frame.

The equations describing the electrical and mechanical behavior of the three phase synchronous generator are:

$$\frac{d\Psi_d}{dt} = -\frac{\Psi_d}{T_{ad}} + \frac{e_q''}{T_{ad}} + \omega\psi_q + \omega_0 V \sin\delta \quad (1)$$

$$\frac{d\Psi_q}{dt} = -\omega\psi_d - \frac{\Psi_q}{T_{aq}} - \frac{e_d''}{T_{aq}} + \frac{e_d''}{T_{aq}} + \omega_0 V \cos\delta \quad (2)$$

$$\frac{de_q''}{dt} = -\frac{x_d'}{x_d''} \frac{e_q''}{T_{do}'} + \frac{e_q'}{T_{do}'} + \left(\frac{x_d' - x_d''}{x_q''} \right) \frac{\Psi_d}{T_{do}'} \quad (3)$$

$$\frac{de_d''}{dt} = -\frac{x_q}{x_q''} \frac{e_d''}{T_{qo}'} - \left(\frac{x_q - x_q''}{x_q''} \right) \frac{\Psi_q}{T_{qo}'} \quad (4)$$

$$\frac{de_q'}{dt} = -\alpha \frac{e_q'}{T_{do}'} + (\alpha - 1) \frac{e_q''}{T_{do}'} + \frac{e_{af}}{T_{do}'} \quad (5)$$

$$\frac{d\delta}{dt} = \omega - \omega_0 \quad (6)$$

$$\frac{d\omega}{dt} = \frac{\omega_0}{2H} \left[T_m + \frac{\Psi_d e_d''}{x_q''} + \Psi_q \frac{e_q''}{x_d''} + \Psi_d \Psi_q \left(\frac{1}{x_q''} - \frac{1}{x_d''} \right) \right] \quad (7)$$

The following is a partial list of the constants and states found in (1) to (7):

- Ψ_d Per-unit direct axis flux linkage
- Ψ_q Per-unit quadrature axis flux linkage
- e_q'' Quadrature-axis voltage behind subtransient reactance
- e_d'' Direct-axis voltage behind subtransient reactance
- e_q' Quadrature-axis voltage behind transient reactance
- ω_0 Base frequency
- δ Rotor phase angle with respect to synchronous reference

- T_{do}'' Direct-axis open-circuit subtransient time constant
- T_{qo}'' Quadrature-axis open-circuit subtransient time constant

- T_{do}' Direct-axis open-circuit transient time constant
- H Ratio of mechanical energy at rated speed to base power

- X_q Quadrature-axis synchronous reactance
- X_q'' Quadrature-axis subtransient reactance
- X_d' Direct-axis transient reactance
- X_d'' Direct-axis subtransient reactance

Depending on the nature of the simulation to be conducted, either the phase currents or phase voltages are assumed known. For balanced three phase operation, the phase quantities may be mapped to or from the rotor reference frame using Parks transformation:

$$\begin{bmatrix} u_d \\ u_q \\ u_0 \end{bmatrix} = \frac{2}{3} \begin{bmatrix} \cos(\theta) & \cos(\theta - \frac{2\pi}{3}) & \cos(\theta + \frac{2\pi}{3}) \\ -\sin(\theta) & -\sin(\theta - \frac{2\pi}{3}) & -\sin(\theta + \frac{2\pi}{3}) \\ \frac{1}{2} & \frac{1}{2} & \frac{1}{2} \end{bmatrix} \begin{bmatrix} u_a \\ u_b \\ u_c \end{bmatrix} \quad (8)$$

$$\begin{bmatrix} u_a \\ u_b \\ u_c \end{bmatrix} = \begin{bmatrix} \cos(\theta) & -\sin(\theta) & 1 \\ \cos(\theta - \frac{2\pi}{3}) & -\sin(\theta - \frac{2\pi}{3}) & 1 \\ \cos(\theta + \frac{2\pi}{3}) & -\sin(\theta + \frac{2\pi}{3}) & 1 \end{bmatrix} \begin{bmatrix} u_d \\ u_q \\ u_0 \end{bmatrix} \quad (9)$$

$$\theta = \int \omega_s dt + \theta_0 \quad (10)$$

A detailed explanation of these equations is beyond the scope of this thesis. An excellent short introduction to modelling synchronous machines is given in [15]. Analysis of electric machinery with thorough treatment of reference frame theory and Park's transformation is presented in [16] and [17].

5. Voltage Regulator Model

Figure 12 shows the block diagram of the excitation system for the MSL. The voltage regulator is of Type II as defined by the IEEE [18]. V_{ref} is a reference voltage supplied to the regulator while V_t is the average terminal voltage. The second half of the block diagram accounts for non-linear saturation effects. The output of this element is the field excitation voltage, $exfd$.

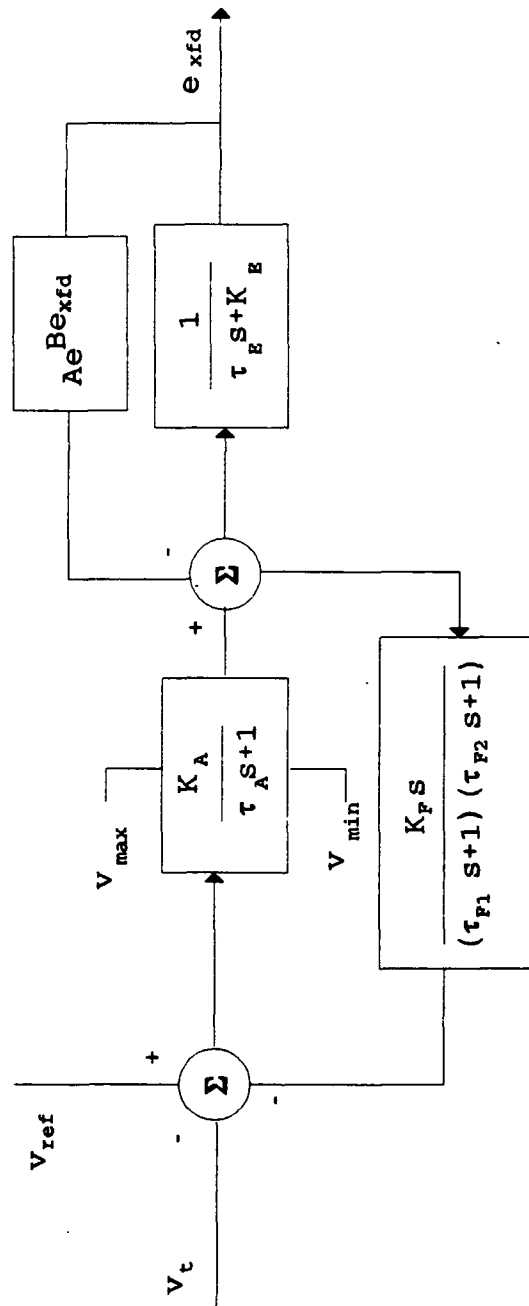

Figure 12 Block diagram of the voltage regulator for the machinery simulation lab [9]

6. Resistive-Inductive Load

For the purpose of testing WAVESIM only a wye connected R-L load model is available. The phase voltages are inputs and the phase currents are outputs. The following equations represent a wye connected RL load [8]:

$$V_a = i_{aL}R_L + \frac{X_L}{\omega_b} \frac{di_{aL}}{dt} \quad (11)$$

$$V_b = I_{bL}R_L + \frac{X_L}{\omega_b} \frac{di_{bL}}{dt} \quad (12)$$

$$V_c = I_{cL} + \frac{X_L}{\omega_b} \frac{di_{cL}}{dt} \quad (13)$$

B. ADDITIONAL MODELS FOR SHIPBOARD ELECTRICAL DISTRIBUTION SYSTEM

A specialized shipboard electrical distribution system studied by Purdue University is shown in Fig. 13. The system consists of two identical ships service turbine generators (SSTGs) supplying main and vital loads. Vital loads are supplied alternate power from a battery backup. DC/AC and AC/DC conversion is accomplished via ships service motor generator (SSMG) sets consisting of a synchronous AC machine mechanically coupled to a DC machine. Normal operation is for the AC machine to act as a motor driving the DC machine to charge the batteries. In a casualty the batteries would

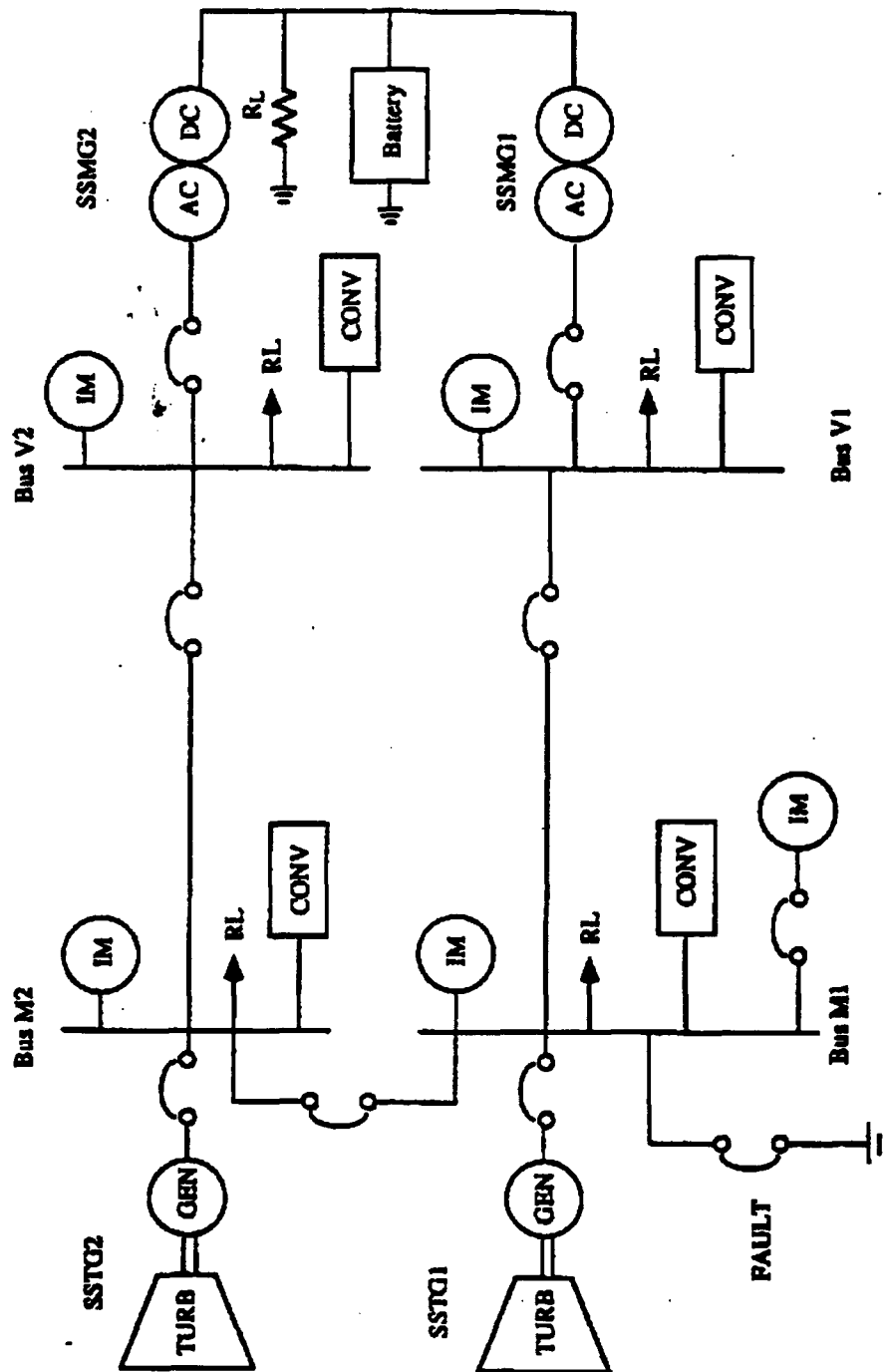

Figure 13 Specialized shipboard distribution system with DC backup [10]

supply the DC machine acting as a motor driving the AC machine to provide vital 60 Hz power. [9]

This system will not be simulated in this thesis since adequate models for WAVESIM are not available; rather, it is an illustration of the type of study that a tool such as WAVESIM is required to perform. Some models required by this study in addition to those presented in the previous section are:

- Induction motors
- Solid-state power converters
- Prime movers
- Static excitation system
- DC conversion system

1. Induction Motor Model

"The induction motor is the workhorse of the electric power industry" [16:p159]. This is true of the Navy as well. The Navy relies heavily on induction motors to drive the hundreds of pumps, fans, and compressors found aboard ship. The equations governing an induction machine in an arbitrary reference frame and using per unit quantities are given in [8].

$$v_{qs} = r_s i_{qs} + \frac{\omega}{\omega_b} \psi_{ds} + \frac{d}{dt} \frac{\psi_{qs}}{\omega_b} \quad (14)$$

$$v_{ds} = r_s i_{ds} - \frac{\omega}{\omega_b} \psi_{qs} + \frac{d}{dt} \frac{\psi_{ds}}{\omega_b} \quad (15)$$

$$v_{0s} = r_s i_{0s} + \frac{d}{dt} \frac{\psi_{0s}}{\omega_b} \quad (16)$$

$$0 = r_r i_{qr} + \left(\frac{\omega - \omega_i}{\omega_b} \right) \psi_{dr} + \frac{d}{dt} \frac{\psi_{qr}}{\omega_b} \quad (17)$$

$$0 = r_r i_{dr} - \left(\frac{\omega - \omega_i}{\omega_b} \right) \psi_{qr} + \frac{d}{dt} \frac{\psi_{dr}}{\omega_b} \quad (18)$$

$$0 = r_r i_{0r} + \frac{d}{dt} \frac{\psi_{0r}}{\omega_b} \quad (19)$$

The per unit flux linkages are given by

$$\psi_{qs} = X_{ls} i_{qs} + X_M (i_{qs} + i_{qr}) \quad (20)$$

$$\psi_{ds} = X_{ls} i_{ds} + X_M (i_{ds} + i_{dr}) \quad (21)$$

$$\psi_{0s} = X_{ls} i_{0s} \quad (22)$$

$$\psi_{qr} = X_{lr} i_{qr} + X_M (i_{qs} + i_{qr}) \quad (23)$$

$$\psi_{dr} = X_{lr} i_{dr} + X_M (i_{ds} + i_{dr}) \quad (24)$$

$$\psi_{0r} = X_{lr} i_{0r} \quad (25)$$

Finally, the per unit torque is given by

$$T_e = \psi_{qr} i_{dr} - \psi_{dr} i_{qr} \quad (26)$$

Rather than detail every variable name, the following general guidelines are provided:

- ω is a rotational speed in radians per second
- λ is the per-unit flux linkage
- X is a reactance
- subscript b base quantity
- subscript q refers to quadrature axis
- subscript d refers to direct axis
- subscript 0 refers to zero sequence axis
- subscript s refers to stator variables
- subscript r refers to rotor variables
- subscript l refers to a leakage reactance
- subscript M refers to the magnetizing reactance

In the above equations ω is the rotational speed of the reference frame. For a stationary reference frame ω is set to zero. Translation to and from the rotor reference frame may be accomplished by Park's transformation's, as given in section A.4 of this chapter.

2. Prime Movers

Prime movers for naval applications vary from internal combustion engines such as large diesel engines and gas turbine engines to high pressure steam turbines. A simple second order model of a steam turbine prime mover which accounts for both plant and servo/steam valve time constants is given in Fig. 14.

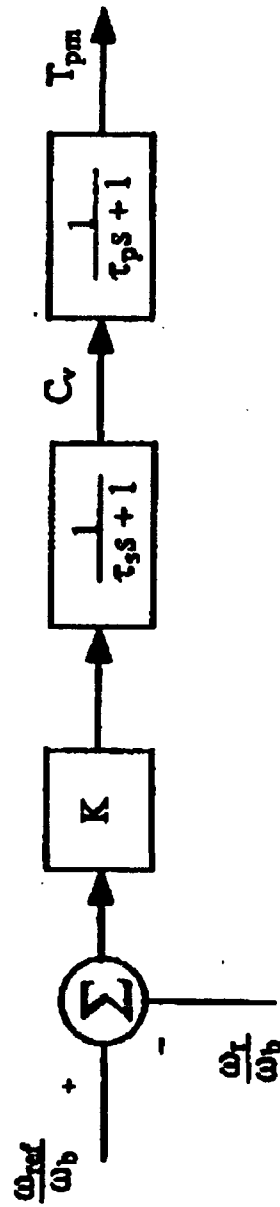

Figure 14 Second order model of a steam turbine prime mover [10]

3. Static Excitation System

Figure 15 which is a representative static excitation system [9]. This diagram is provided as an example of the complexity of the models that need to be modelled. A detailed explanation for this excitation system may be found in [9] or [13].

4. DC System

The distribution system shown in Fig. 13 is highly specialized yet it demonstrates an important requirement for power system simulations: the ability to simulate abruptly changing topologies. Figure 16 shows the DC subsystem of Fig. 13. Note that a switch determines the mode of operations of the DC subsystem. In normal operation the DC machine acts as a generator. The feedback is based on the field excitation to maintain proper DC voltage output. In emergency operation, feedback is based on a reference speed necessary to maintain the appropriate frequency of the synchronous machine now acting as a generator. [10]

5. Solid-state Power Converters

The three phase uncontrolled diode rectifier shown in Fig. 17 is a simple three phase power converter. This device produces an uncontrolled DC voltage output from a three phase sinusoidal input. Figure 18 is the equivalent circuit for Fig. 17 as given by [19:p.27].

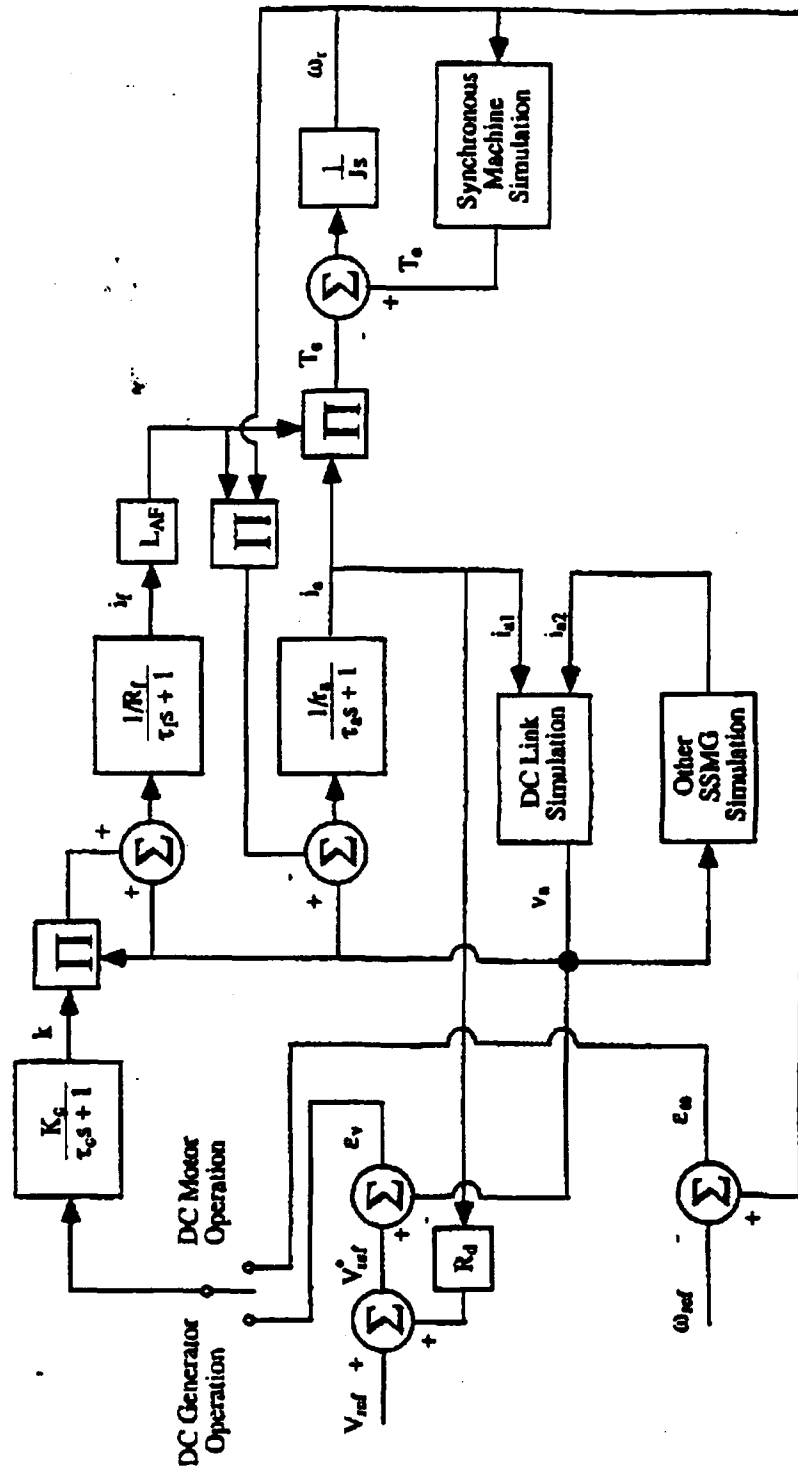

Figure 16 DC subsystem of a ships power system with DC backup [10]

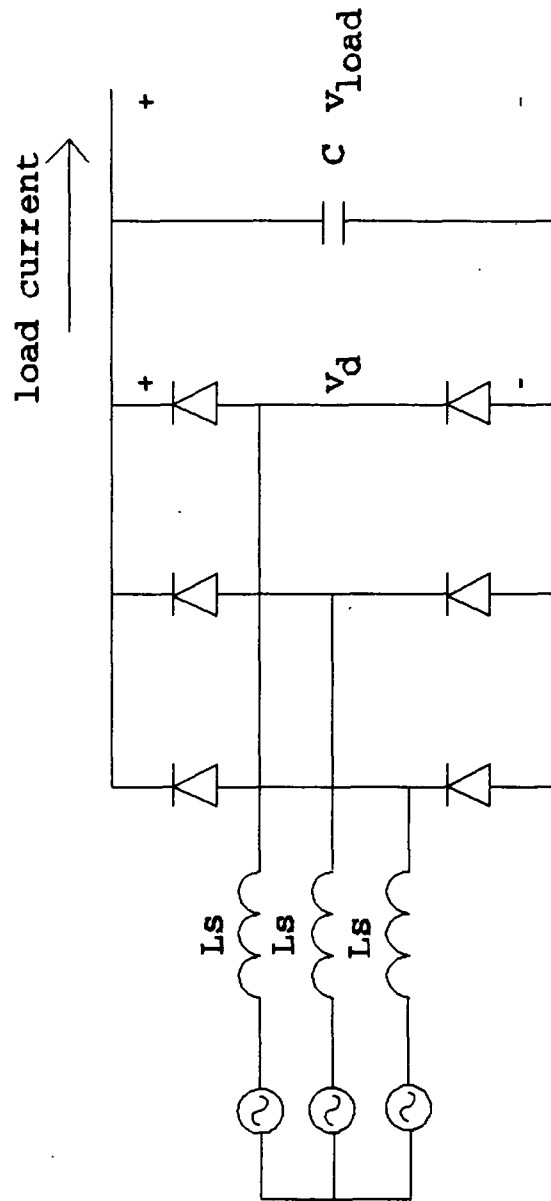

Figure 17 Three phase full-bridge rectifier [19:p27]

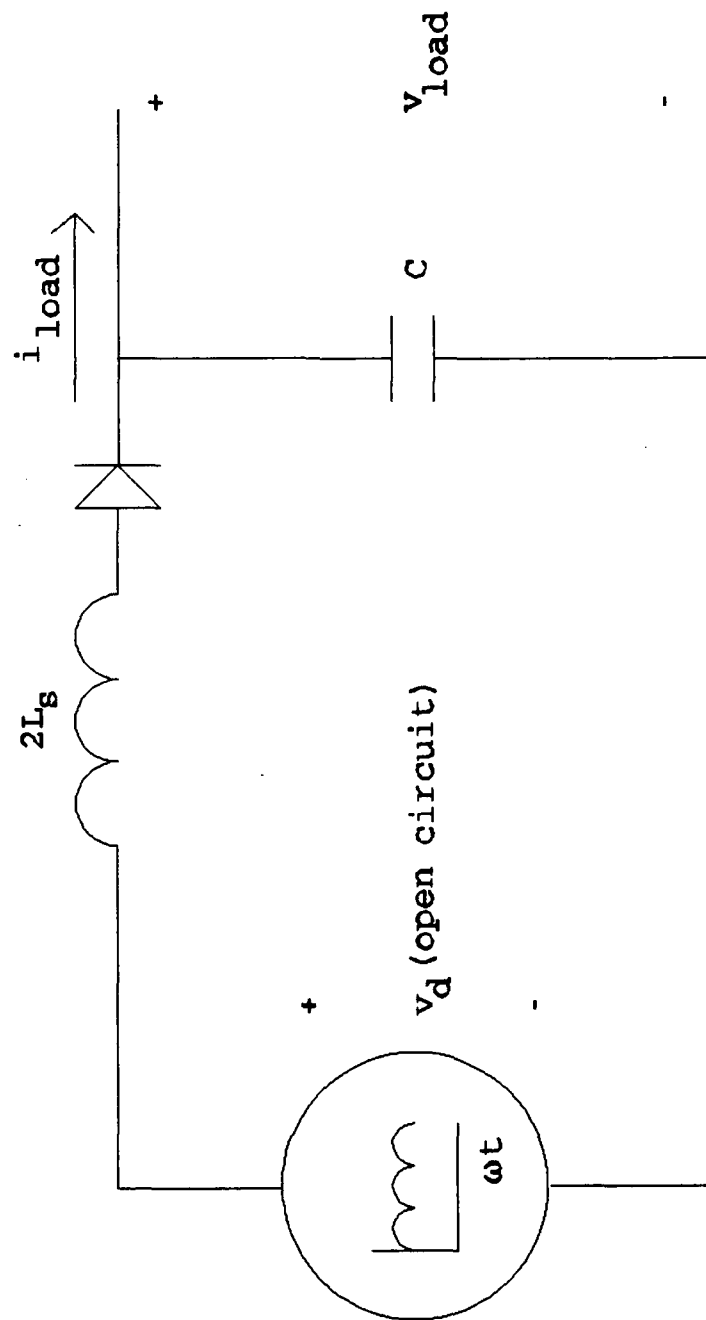

Figure 18 Equivalent circuit for a three-phase full-bridge rectifier [19:p.27]

V. DETAILED DESCRIPTION OF WAVESIM

A. WHAT IS WAVESIM

WAVESIM is a computer program developed by LT Norbert Doerry, USN at the Massachusetts Institute of Technology [1]. It is designed to perform detailed digital simulation of systems of linear and nonlinear devices. The ultimate objective in developing WAVESIM is to simulate ship's IED systems. With properly developed device modules, however, it should be capable of modelling any system of non-linear devices.

In its current form WAVESIM is a demonstration project only. It consists of a collection of source code files written in the C programming language, MATLAB script files, and specially formatted files defining both device input/output and system connections. The types of files are:

- WAVESIM source code (.c files and .h files)
- Waveform operators (MATLAB script files)
- Definition files (special format files with extension .def)
- Device constitutive files (MATLAB script files)
- Input files (special format files with extension .in)

1. WAVESIM Source Code

WAVESIM itself is written in ANSI standard C and is highly portable. The program has been compiled and executed on a variety of platforms including Sun SPARC2 work stations, VAXSTATION 3100 and VAX 11/785, and IBM Personal Computers. The output of WAVESIM is a simulation file in the form of a script or .m file for execution under MATLAB by Mathworks, Inc. WAVESIM takes advantage of MATLAB's extensive vector mathematics capability. The simulation files are intended to be used as provided. The user should have no reason to modify them.

2. Waveform Operators

WAVESIM uses waveform representation of interface variables and gives the user the option of several representations. The waveform operators supplied with the program as MATLAB functions perform all the required mathematical operations. These operations include converting from one representation to another, finding derivatives, computing integrals over an interval, smoothing, and arithmetic operations. These waveform operators are used both by the device constitutive files and by the simulation files generated by WAVESIM. These files are intended to be used as provided. The user should have no reason to modify them.

3. Definition Files

Files describing the device have the extension *.def*. Each device must be defined in the special format of the *.def* file. The device definition file provides the following information [1]:

- Name of device type
- Number, names, and default values of parameters
- Number, names, and default initial values of states
- Number of terminals
- Terminal names
- Terminal Types (normal or information)
- Flow variable types (import or export)
- Potential variable types (import or export)
- Terminal KCL group numbers
- Device structural jacobian

Users desiring to add devices to the library must prepare a new *name.def* file in the format given in [1]. The main *.def* file is *device.def*. This file contains debugging information and lists all defined devices either with complete definitions or with include statements. *Device.def* must be present for WAVESIM to operate. New device definitions may be added directly to *device.def* or, the preferred method is to develop a separate *name.def* file and add it to the library using an include statement in *device.def*.

The information provided by the device definition file is sufficient to combine devices and reduce the resulting system of equations into solvable blocks. However, no information is provided on the constitutive relationship of the systems variables. This information is provided by the device *.m* files.

4. Device Files

Device files are MATLAB script files that detail the constitutive relationships of the import and export variables of a device. Doerry lists the properties of these files in terms of resources and products of the file [1]. The resources are:

- Waveform type
- Import variable waveform
- Parameter values
- Value of states at beginning of time interval
- Time Structure
- Beginning time of interval
- Ending time of interval
- Minimum time of interval of interest
- Continuation parameter

With these resources WAVESIM uses the device file to calculate the following products:

- Export variable waveforms

- Device jacobian matrix
- Value of states at end of time interval
- Recommended time structure
- Recommended recalculation time this interval
- Recommended ending time of next interval

5. Input Files

Input files have the extension .in and are written by the user. The input files initialize WAVESIM in regard to the system being studied. The file is command oriented with seven available commands [1]:

- | | |
|-----------|-------------------------------|
| ● Debug | Print debug information |
| ● Default | Set default system parameters |
| ● Device | Specify device information |
| ● Include | Include another file |
| ● Node | Specify node parameters |
| ● Time | Control time increments |

Commands may be either a single line or they may be multiple lines as designated by placing the command on a line by itself followed by a list of subordinate commands and ending with the word *END*.

The following is a brief summary of each of the commands.

a. *Debug*

WAVESIM has numerous built in debugging modules. These modules print out various simulation data as the

simulation progresses to allow the user to identify problems with the simulation. The type of information available includes all the devices defined by WAVESIM, structural jacobian, file data, and construction of various blocks.

b. Default

Control of the simulation is exercised with the default command. In all there are eleven subordinate default commands, most with multiple elements. The subordinate commands are:

- alpha--Control the continuation parameter.
- check--Error checking flags.
- diverge--Control of divergence test.
- error--Set default error levels.
- gmin--Set default node leakage conductance.
- max--Set maximum number of iterations.
- nbr--Control number of coefficients in waveform representation.
- rmin--Set default series resistance.
- scale--Set default node scaling factors.
- waveform content--Set waveform content limits.
- wtype--Set default waveform type.

With experience, tight control of the simulation and error control are achievable using the default settings.

c. Device

The topology of the system being modelled is specified by the device command and its subordinates. A given system may contain multiple occurrences of a given device type (i.e. multiple resistors). Each particular device is given a unique name by which it is identified throughout the simulation. The name is assigned as part of the device command. The device subordinate commands are:

- Terminal
- Parameter
- States

(1) Terminal

The terminal subordinate command assigns terminals to specific nodes and hence specifies the system topology. Each terminal of a device must be assigned to a node. The rules governing assignment of terminals to nodes are given in [1].

(2) Parameter

The use of parameters in device definitions allows for one device model to be written for each device type. For example, a synchronous generator may be a 2 MW unit with its associated parameters or it may be a 750 KW unit with its associated parameters but both may use the same device model. Default values of parameters are specified in the device.def

files. Parameters in the device command override default values. (3) *States*

Doerry gives the following definition of states [1: p.46]:

STATES are variables whose values are stored for a given time for later use. States can be used for example, to store the constant of integration for a dynamic equation. States can also be used to store the operating mode for a given device. In general, if the value of a given variable depends on the previous value of another variable that other variable is a state.

The *device states* subordinate command allows the user to initialize a given state. This may be crucial to the simulation since an iterative technique is used to solve the systems or algebraic equations representing the plant. The iterative method used is Newton-Raphson. A region of convergence is located around each solution to a non-linear algebraic equation. Proper initializing of the system may be key to obtaining the correct solution. This is discussed further in section B.4 of this chapter.

d. *Include*

The *include* command inserts a specified text file at the location of the include statement.

e. *Node*

The *node* command specifies node-specific parameters. For instance, the user may specify a resistance (*Rmin*) or conductance (*Gmin*) to ground to reduce linear dependencies among the systems of equations at a particular

node. Doerry details the use of Rmin and Gmin to address singularities in the jacobian matrix [1:p.53]. Maximum equation errors and maximum variable corrections may also be specified for a given node. Other subordinate node commands include name, to name a particular node, and scale, to override default scale factors for potential or flow variables at a particular node.

f. Time

The time command specifies start and finish times for the simulation as well as allowing the insertion of break points and controlling time increments. Break points can be inserted at the time of known discontinuities to speed the simulation by ensuring that a waveform boundary occurs at the discontinuity. The problem of waveform representation at discontinuities and the difficulties this imposes when conducting a detailed simulation involving power converters is addressed in section B.3 of this chapter.

Time increment control includes the ability to specify maximum, minimum, optimum, and initial time increment as well as the minimum time interval of interest which is used to by devices to smooth export variables and discontinuities. WAVESIM varies the simulation time for each step depending on the progress of the simulation.

g. Plot

The plot command specifies which system variables need to be converted to data series and plotted in MATLAB. Only variables specified by the plot command are converted to data series for output.

B. SOLUTION METHOD USED IN WAVESIM

1. Device Modelling

WAVESIM device models are developed using terminal descriptions. With terminal descriptions a device is assigned variables for flow and potential at each terminal. Device constitutive relationships are then developed in terms of these variables. In contrast, most engineers are familiar with branch descriptions in which flow variables are written in terms of the relative potential difference between terminals. Figure 19 is a simple example of branch vs terminal descriptions for a two terminal device.

Doerry defines the variables v_1 , i_1 , v_2 , and i_2 in Fig. 19 as interface variables. These variables are the means by which various devices interact. Interface variables may be either potential variables (voltage, speed, pressure, etc.) or flow variables (current, torque, fluid flow rate, etc.). Interface variables are further characterized as imports, which devices see as a resource, or as exports, which the device sees as a product. [1:p44]

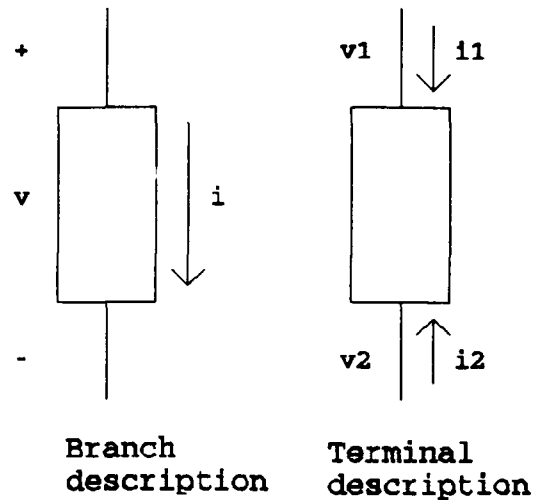

Figure 19 Branch vs Terminal Description [1:p.15]

Doerry describes the device description in two ways
 ... an organized manner for describing the characteristics
 of a physical component [1:p.44];

... a means for generating export variables based on the
 values of the import variables, states, parameters,
 continuation parameter, and time [1:p.45].

The continuation parameter associated with the Newton-Raphson
 method of solving systems of non-linear algebraic equations
 will be discussed in part 4 of this section.

For the device shown in Fig. 19 assume the flow
 variables, i_1 and i_2 , are defined as export variables and the
 potential variables, v_1 and v_2 , are defined as import

variables. The device constitutive equations might then be expressed as

$$i_1 = g_{i1}(v_1, v_2) \quad (27)$$

$$i_2 = g_{i2}(v_1, v_2) \quad (28)$$

These equations, expressed on the device level, are used by WAVESIM to satisfy the system equations.

Two more products of the device object are the device jacobian matrix and the device structural jacobian matrix. The device jacobian matrix expresses the sensitivity of a given export variable to a change in a given export variable.

The device structural jacobian matrix ... describes the properties of the elements of the device jacobian matrix for a given type of variable representation without providing any values [1:p.48]

For an ordered set of import variables

$$X_I = \begin{bmatrix} X_{I1} \\ X_{I2} \\ \cdot \\ \cdot \\ \cdot \\ X_{IK} \end{bmatrix} \quad (29)$$

and an ordered set of export variables

$$X_E = \begin{bmatrix} X_{E1} \\ X_{E2} \\ \cdot \\ \cdot \\ X_{EK} \end{bmatrix} \quad (30)$$

the device jacobian matrix is given by

$$J = \begin{bmatrix} \frac{\partial X_{E1}}{\partial X_{I1}} & \frac{\partial X_{E1}}{\partial X_{I2}} & \cdots & \frac{\partial X_{E1}}{\partial X_{IK}} \\ \frac{\partial X_{E2}}{\partial X_{I1}} & \frac{\partial X_{E2}}{\partial X_{I2}} & \cdots & \frac{\partial X_{E2}}{\partial X_{IK}} \\ \cdot & \cdot & \cdot & \cdot \\ \cdot & \cdot & \cdot & \cdot \\ \frac{\partial X_{EK}}{\partial X_{I1}} & \frac{\partial X_{EK}}{\partial X_{I2}} & \cdots & \frac{\partial X_{EK}}{\partial X_{IK}} \end{bmatrix} \quad (31)$$

The elements of the device jacobian matrix may be scalar values or matrices depending on how variables are represented (i.e. by real numbers or by waveform representation).

[1: pp.47-48]

The device structural jacobian matrix gives the mathematical nature of the device jacobian matrix. Table II lists the codes used in the device structural jacobian.

TABLE II CODES FOR STRUCTURAL JACOBIAN MATRIX [1: p. 48]	
Code	Type of Matrix
0	Zero matrix (all elements always zero)
I	Identity matrix (always the identity matrix)
D	Diagonal (always a linear main diagonal matrix)
L	Linear matrix (The elements are always constant.)
A	Nonlinear AC matrix (See note below.)
N	Nonlinear Matrix (The elements may not be constant.)
U	Unknown (The dependence is unknown. Treat as nonlinear.)

Doerry defines a nonlinear AC matrix as

... one for which the constant component of the export variable depends only on the constant component of the import variable. The other components of the export variable cannot depend on the constant component of the import variable but are not restricted in any other way [1:p. 48].

Device structural jacobians are combined by WAVESIM to build a system structural jacobian which will be discussed in the following section. Further, the device structural jacobian identifies which elements must be recalculated between iterations if an iterative type solution is used.

Lastly, device models provide WAVESIM with a recommended recalculation time for the current interval. Waveform representation of variables may be inaccurate at discontinuities unless a waveform boundary falls at the time of the discontinuity. Therefore, if a device constitutive equation is discontinuous, the model recommends a new interval causing the waveform boundary to fall at the discontinuity. WAVESIM will generally use the minimum recalculation time suggested by any of the devices.

2. Building a System of Equations and Block Reduction

WAVESIM uses an adaptation of modified nodal analysis to develop system equations. Figure 20 is used by Doerry to demonstrate this procedure.

System variables are defined as

The minimum set of variables from which all of the device import and export variables can be derived [1:p.51].

System variables that must be solved for in Fig. 20 are i_{s1} , i_{c1} , e_0 , e_1 , and e_2 . This information is based on a knowledge of how the particular devices in Fig. 20 are modelled: which terminal variables each model uses as imports and which are exports. The KCL equations are written for each node using the constitutive equations yielding:

$$i_{s1} + g_{R_iR1}(e_1, e_2) = 0 \quad (32)$$

$$i_{c1} + g_{R_iR2}(e_1, e_2) = 0 \quad (33)$$

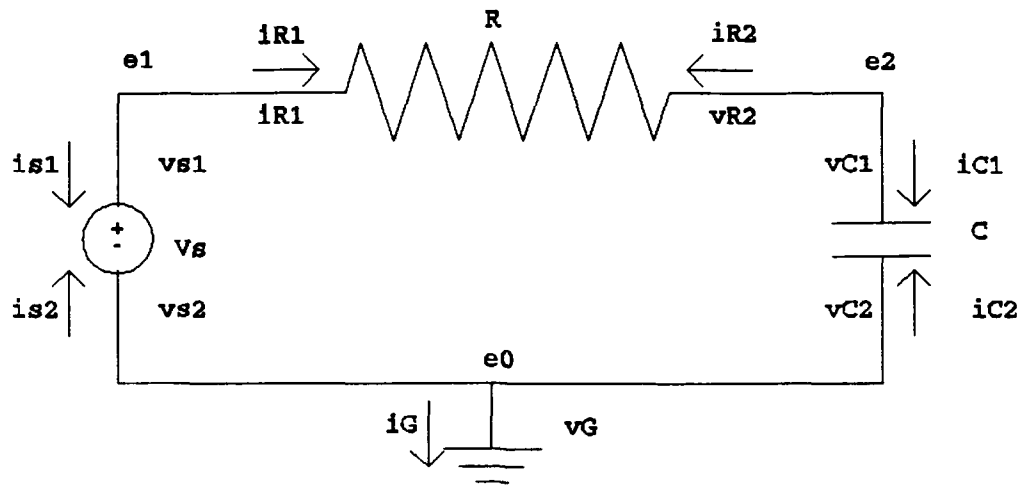

Figure 20 Terminal description of an RC circuit [1:p.23]

$$i_G + g_{S_{is2}}(i_{S1}, e_0) + g_{C_{ic2}}(i_{C1}, e_0) = 0 \quad (34)$$

Notice that the device constitutive equations are not known on the system level. Next the potential difference equations are written between each node potential and each export potential variable associated with a normal or information node.

$$e_1 - g_{C_{vc1}}(i_{C1}, e_0) = 0 \quad (35)$$

$$e_2 - g_{S_{vs1}}(i_{S1}, e_0) = 0 \quad (36)$$

$$e_0 - g_{G_{vg}}(i_G) = 0 \quad (37)$$

The total number of system equations to be solved is equal to twice the number of normal nodes plus the number of information nodes.

For some systems the number of equations to be solved may be very large. However, Doerry points out in the example above that the system may be broken into a set of blocks which may be solved individually resulting in a faster solution. The above equations may be broken into two 1X1 blocks, one 2X2 block, and 2 more 1X1 blocks [1:p.24]. WAVESIM's method of identifying blocks to be sequentially solved uses the system structural jacobian.

The first step in developing a system structural jacobian is to order the system variables and system equations. The system structural jacobian is then produced by combining device structural jacobians according to the arithmetic of structural jacobian elements. Recall Table 2 which lists the codes used in structural jacobians. The arithmetic used to combine these elements is dependent on the representation of the variables of interest according to the following arithmetic rules [1:p.58]:

$$\begin{aligned}
 I+I &= D \\
 I-I &= 0 \\
 I\pm 0 &= I \\
 -I\pm 0 &= D \\
 -I\pm I &= D
 \end{aligned}
 \tag{38}$$

$$\pm n \pm m = \pm m \pm n = n \quad (n \geq m, n \neq I)$$

The resulting system structural jacobian now shows the nature of the dependence of system equations to each of the system variables.

The system structural jacobian facilitates reducing the system of equations into smaller, more easily solved blocks. Blocks are identified in order and each block depends on system variables either previously solved for or system variables solved within the current block. Doerry provides algorithms for ordering equations, building the system structural jacobian and reducing the system into blocks. The best reduction results in the largest number of small blocks.

[1:pp.59-60]

Once the reduced system of equations is built the individual blocks are solved. Each block is itself a small system of algebraic equations which may be solved using an iterative technique such as Gauss-Seidel, Gauss-Jacobi, or Newton-Raphson.

3. Waveform Representation of Interface Variables

The simulation of dynamic systems using a digital computer requires numerical integration or differentiation. Numerical techniques require close attention to the time step used due to requirements on accuracy and the potential problem of numerical stability. Problems arise if the system of equations is stiff. A stiff set of equations is one with widely varying time constants. Unfortunately conditions

unique to the relatively small power plant associated with shipboard power systems result in a tightly coupled the system described by a stiff set of equations.

WAVESIM addresses the problem of tightly coupled systems using waveform representation of system variables. The simulation is broken into distinct time intervals. WAVESIM adjusts these time intervals from step to step depending on the behavior of the system being studied. Over each time interval the system variables are represented as vectors of coefficients. To arrive at the time domain values of the variables, the vector components are interpreted as coefficients of a particular type of series. The minimum information necessary to convert the vector of coefficients to a time domain solution is [1: p.63]:

- beginning and ending times of interval
- number of coefficients
- type of series used in the representation
- a unique name or identifier
- the vector of coefficients.

WAVESIM has available the following series available to represent system variables:

- Legendre series
- Data series
- Fourier series
- Chebyshev series
- Polynomial series

WAVESIM uses the waveform content of the highest order term in the series as a measure of the accuracy of the representation. Waveform content is simply the magnitude of the highest order term divided by the square root of the sum of the squares of all the coefficients.

The advantages of waveform representation over conventional methods are [1:p.62]:

- Interpolation between time increments is not required. The value of any variable may be readily determined at any time.
- Numerical stability of integration and differentiation is not an issue. Time step control is strictly a matter of numerical accuracy. Integration and differentiation are linear matrix operators when using waveform methods.
- Conversion between waveform types is usually a linear matrix operation allowing the most efficient waveform type to be used depending on the operation being performed.

A major difficulty arising with the use of waveform operators is that the accuracy of waveform representation decreases sharply if the function represented is discontinuous. In order for the function to be accurately represented, waveform boundaries should fall at the time of the discontinuity. In simulating a system in which the time of a discontinuity is known this problem is simply addressed by inserting a breakpoint in the input file. An example of this situation might be when conducting a system fault study in which a particular phase or phases are grounded at a known time. Breakpoint insertion is not viable if a system modelled includes solid state power converters. Doerry identifies the

need for robust and accurate methods to predict discontinuities [1:p.163].

4. Newton-Raphson Solution to Systems of Algebraic Equations

The systems of possibly non-linear equations resulting from the reduction of the network being studied may be solved using an iterative technique to generate a consistent set of import variables. An initial estimate is made for the solution and the equations are solved and compared to the known output resulting in an error. Based on this error, corrections are generated and added to the assumed solution. This process is repeated with the new assumed conditions until the error for all system variables is less than a specified threshold. The method used to generate the correction to the assumed solution differentiates between the various solution methods. WAVESIM uses the Newton-Raphson algorithm modified to include a continuation parameter as discussed below. The basic Newton-Raphson method begins with a set of algebraic equations

$$f(x) = \begin{bmatrix} f_1(x) \\ f_2(x) \\ \cdot \\ \cdot \\ \cdot \\ f_N(x) \end{bmatrix} = y \quad (38)$$

where \mathbf{y} and \mathbf{x} are vectors and $\mathbf{f}(\mathbf{x})$ is a vector of functions. Equation (38) may be rewritten

$$\mathbf{y} - \mathbf{f}(\mathbf{x}) = 0 \quad (39)$$

Making an initial guess for \mathbf{x} (the inputs) the corrected solution is

$$\mathbf{x}(i+1) = \mathbf{x}(i) + \mathbf{J}^{-1}(i) [\mathbf{y} - \mathbf{f}(\mathbf{x}(i))] \quad (40)$$

The matrix \mathbf{J}^{-1} used to correct each guess is the inverse of the jacobian matrix. This matrix is based on the Taylor series expansion of $\mathbf{f}(\mathbf{x})$ about an operating point $\mathbf{x}(i)$

$$\mathbf{y} = \mathbf{f}(\mathbf{x}(i)) + \left. \frac{d\mathbf{f}}{d\mathbf{x}} \right|_{\mathbf{x}=\mathbf{x}(i)} (\mathbf{x} - \mathbf{x}(i)) + \frac{1}{2!} \left[\left. \frac{d^2\mathbf{f}}{d\mathbf{x}^2} \right|_{\mathbf{x}=\mathbf{x}(i)} (\mathbf{x} - \mathbf{x}(i))^2 + \dots \right] \quad (41)$$

Neglecting higher order terms and solving for \mathbf{x}

$$\mathbf{x}(i+1) = \mathbf{x}(i) + \left[\left. \frac{d\mathbf{f}}{d\mathbf{x}} \right|_{\mathbf{x}=\mathbf{x}(i)} \right]^{-1} [\mathbf{y} - \mathbf{f}(\mathbf{x}(i))] \quad (42)$$

By comparing (40) and (42) \mathbf{J}^{-1} is given by (43).

One can observe that the Jacobian matrix must be non-singular if Newton-Raphson is to be used. [20]

There are multiple reasons why Newton-Raphson may fail to arrive at a correct solution for a nonlinear algebraic

$$J^{-1} = \left[\frac{df}{dx} \Big|_{x=x(i)} \right]^{-1} = \begin{bmatrix} \frac{\partial f_1}{\partial x_1} & \frac{\partial f_1}{\partial x_2} & \cdots & \frac{\partial f_1}{\partial x_N} \\ \frac{\partial f_2}{\partial x_1} & \frac{\partial f_2}{\partial x_2} & \cdots & \frac{\partial f_2}{\partial x_N} \\ \cdot & \cdot & \cdot & \cdot \\ \cdot & \cdot & \cdot & \cdot \\ \frac{\partial f_N}{\partial x_1} & \frac{\partial f_N}{\partial x_2} & \cdots & \frac{\partial f_N}{\partial x_N} \end{bmatrix}_{x=x(i)}^{-1} \quad (43)$$

equation. The path traced by x for successive iterations is referred to as the trajectory. Around each solution (there may be multiple solutions to a nonlinear equations) there is a region of convergence. If the initial guess is within the correct region of convergence the trajectory will converge to a correct solution. If the initial guess is not within this region of convergence one of five outcomes is possible [1:p.72]:

- The trajectory may diverge
- The solution, may by chance, enter the region of convergence hence arriving at a correct solution
- The Jacobian matrix may become singular
- The trajectory may become cyclic
- The trajectory could enter a chaotic region from which it does not emerge, become cyclic, or converge to the correct solution.

The nature of the nonlinear equations determines the size of the region of convergence. For linear equations, the region of convergence is infinite.

WAVESIM addresses convergence issues using a method known as homotopy in which the continuation parameter mentioned in the discussion of device modelling is used. This method attempts to drive the solution trajectory into the region of convergence in the following manner. Given a nonlinear equation

$$F(x, y) = 0 \quad (44)$$

a new equation is generated

$$F'(x, y, \alpha) = 0 \quad (45)$$

where

$$\begin{aligned} F'(x, y, 0) &= G(x, y) \\ F'(x, y, 1) &= F(x, y) \end{aligned} \quad (46)$$

$G(x, y)$ is a linear function of x . WAVESIM accomplishes this by setting

$$H(x, y, \alpha) = \alpha H(x, y) - (1 - \alpha) G(x, y) \quad (47)$$

Each nonlinear device model should include a linearized set of constitutive equations to support this function. [1:p.75]

Through the use of the *default* command the user may set the initial value, the initial increment, and the minimum

increment of α . Two approaches for using α to arrive at a correct solution are presented [1:p.75].

One method begins with $\alpha=1$. If the algorithm fails to converge to a solution after a predetermined maximum number of iterations, α is decremented. This process is continued until the region of convergence (which is assumed to increase in size with decreasing α) encompasses the initial guess. The parameter α is then incremented and theoretically the trajectory converges on the correct solution.

The other method given in [1] is to start with $\alpha=0$. Since $G(x,y)$ is a linear function the region of convergence is infinite. The parameter α is then incremented and the initial guess is stepped towards the solution. Doerry demonstrates however, that this method is not always successful due to "bifurcations of solutions as α is incremented." [1:p.75]

C. WAVESIM ALGORITHM

Figure 21 shows the simulation flow chart for WAVESIM [1:p.77]. The first portion of the program reads the input file, builds the structural jacobian, initializes the simulation parameters, detects the block sequence and reduces the system. The next portion of the program sequentially solves the given blocks. Figure 22 expands the "solve blocks" portion of Fig. 21 to show the steps required to solve individual blocks [1:p.84]. Note that "success returned" is reached only if:

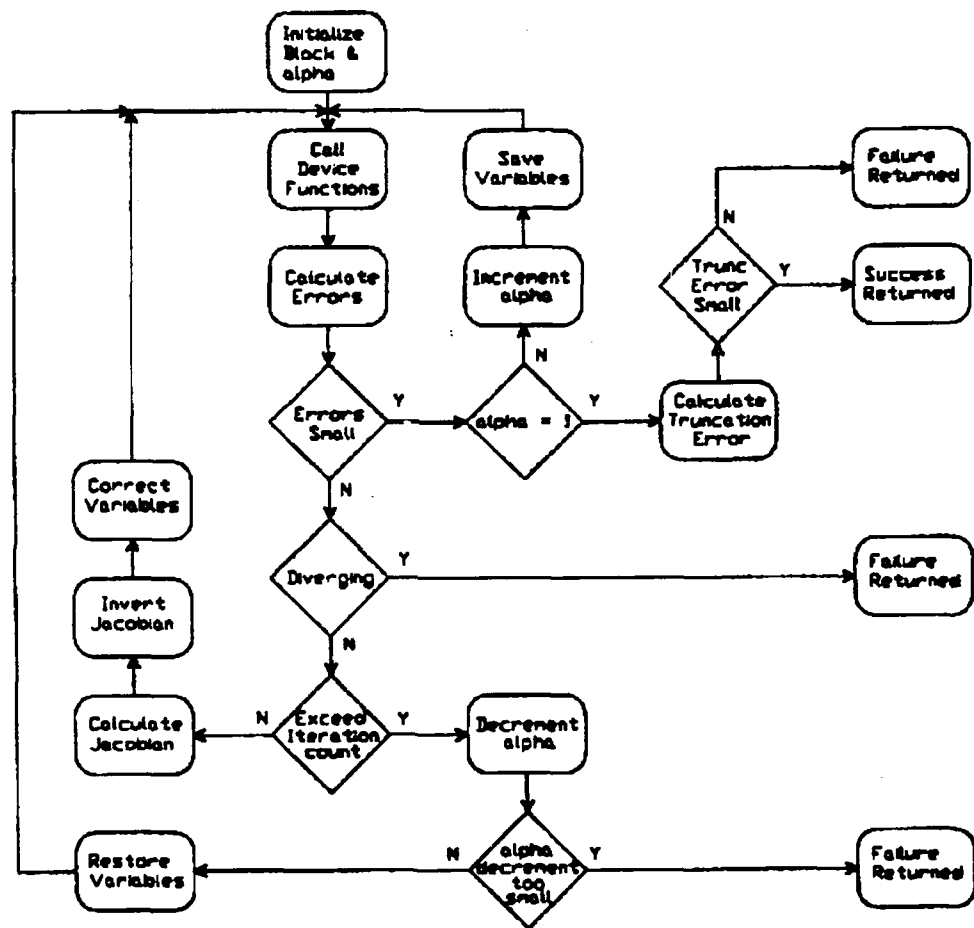

Figure 21 Flow chart of WAVESIM simulation algorithm
[1:p.77]

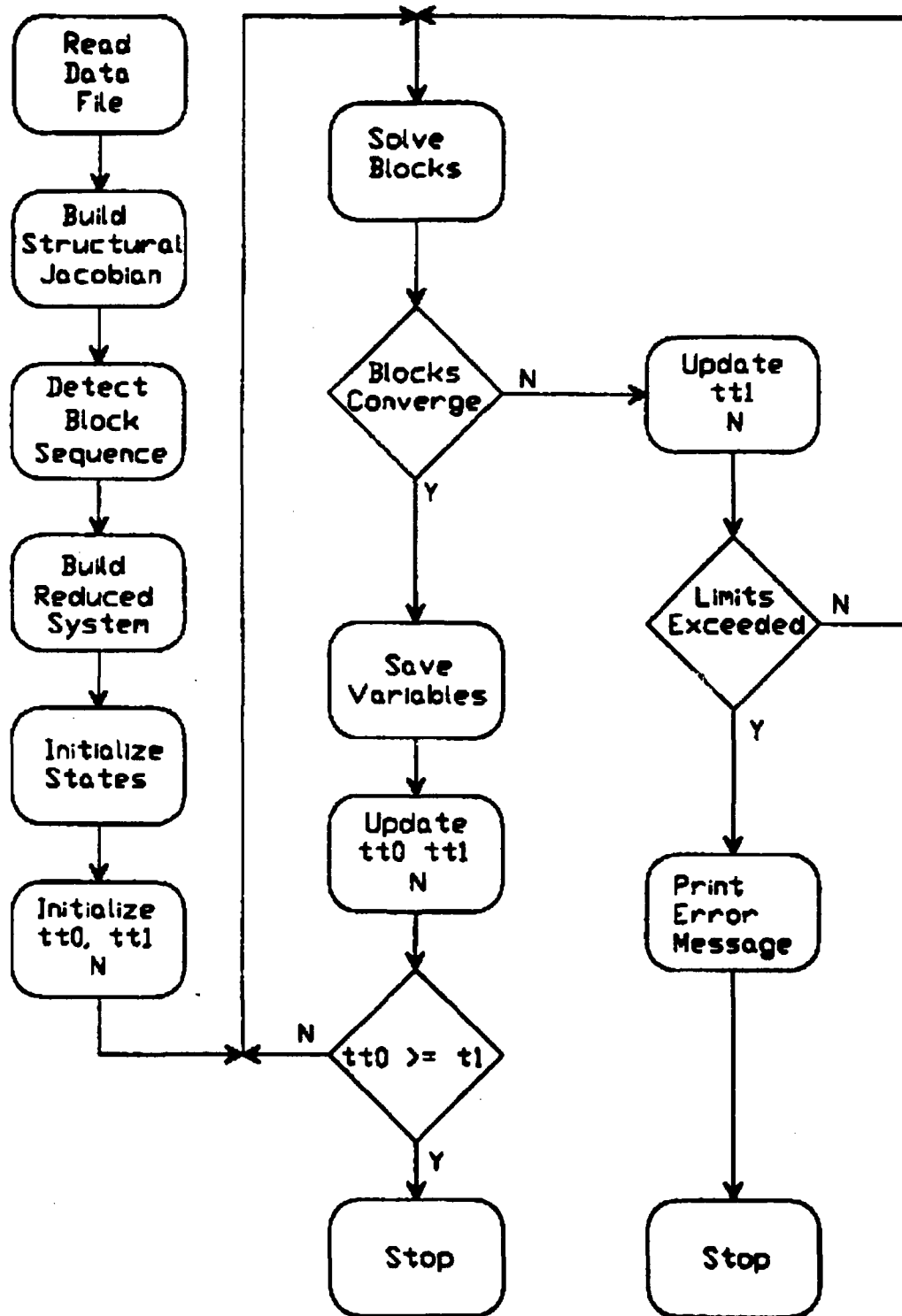

Figure 22 Flow chart for "solve blocks" portion of Fig. 21 [1:p.84]

- the calculated errors (for the assumed solution) are small
- $\alpha = 1$
- The truncation error is within limits

Failure is returned if:

- after an apparently successful convergence the truncation error is too large
- the solution is diverging between iterations
- the allowable number of iterations is exceeded and α is too small

If the blocks successfully converge then the solution for the given time interval is saved and the new time interval is computed and solved. This process continues until the simulation is complete.

If a block fails to converge either the ending time of the current interval is reduced (hence the interval duration is shortened) or the number of coefficients is increased (the program decides which action to take). If the specified limits of the time interval control and number of coefficients are not exceeded, the program will attempt to solve the blocks for the new conditions. However, if the simulation limits are exceeded, the program terminates and prints an error message.

VI ANALYSIS AND TESTING OF WAVESIM

The purpose of this thesis is to develop a set of metrics to evaluate software used to conduct detailed modelling of shipboard power systems using digital computers. Chapter II section D.3 introduces two efforts in this area. Chapter III enumerates a set of metrics as derived from work in the area of detailed digital modelling of power systems. This chapter will evaluate WAVESIM in terms of the metrics presented in Chapter III.

A. STUDY APPROACH

The analysis of WAVESIM will be conducted in two steps. The first step is to run WAVESIM. The second step is to evaluate WAVESIM in terms of the metrics enumerated in Chapter III. To accomplish this the turbine emulator of the MSL, introduced in Chapter II section D.1 and described in detail in Chapter IV section A, will be modelled using devices supplied by LT John Amy, USN, of the Massachusetts Institute of Technology. Each component of the turbine emulator will be tested individually and then the entire turbine emulator model will be tested. Also the voltage regulator model with its non-linear saturation effects will be tested to study the ability of WAVESIM to model non-linear devices.

The response of the turbine emulator and its individual components to a pulse disturbance will be simulated. Steady state operation with zero error will be established followed by the application of a pulse disturbance. The duration of the disturbance will be adequate to once again establish steady state. Finally, the system will be allowed to settle to steady state following termination of the disturbance. Similar simulations will be conducted using the software package SIMULAB by The Math Works, Inc. and the results will be compared.

For both parts of the evaluation of WAVESIM, modelling the turbine emulator and comparing WAVESIM to the metrics presented, the program and models are treated as a commercial package. No effort is made to correct problems within device models nor are additional device objects developed. While it is noted that system developers would, in most cases, build some of their own models to account for the uniqueness of a system under study, at this time WAVESIM is not adequately developed to make this a worthwhile effort.

B. MODELING THE TURBINE EMULATOR

1. Speed Regulator

The block diagram for the speed regulator is given in Fig. 9 of Chapter IV. The parameters for this device as given by Mayer are [14]:

- $K_s = 5.3 \times 10^{-3}$
- $K_{s1} = 4$
- $\tau_{s1} = .561$ seconds
- $\tau_{s2} = 28 \times 10^{-3}$ seconds
- $\tau_{s3} = 6.028 \times 10^{-3}$ seconds
- $\tau_{s4} = .9$ seconds
- $\tau_{s5} = .45$ seconds
- $\tau_{s6} = 5 \times 10^{-3}$ seconds
- $C_1 = 4.107 \times 10^{-3}$ Volts/Ampere

The test was conducted with $\omega_{ref} = 188.5$ radians/second. The motor speed was input according to:

$$\omega_m = \begin{cases} 188.5 \text{ rad/sec} & t < 4 \text{ seconds} \\ 94.25 \text{ rad/sec} & 4 < t < 8 \text{ seconds} \\ 188.5 \text{ rad/sec} & 8 < t \text{ seconds} \end{cases} \quad (48)$$

A fixed time step of 1 ms was used for the WAVESIM simulation and for the SIMULAB simulation. Figure 23 is a plot of the WAVESIM results superimposed on the SIMULAB results. The reader will observe the discrepancies between the SIMULAB and the WAVESIM results. WAVESIM fails to accurately depict the dynamic response and omits the fast transients associated with the step inputs resulting in potentially erroneous values of the maximum and minimum currents in the circuit. Table III summarizes the data provided by Fig. 23.

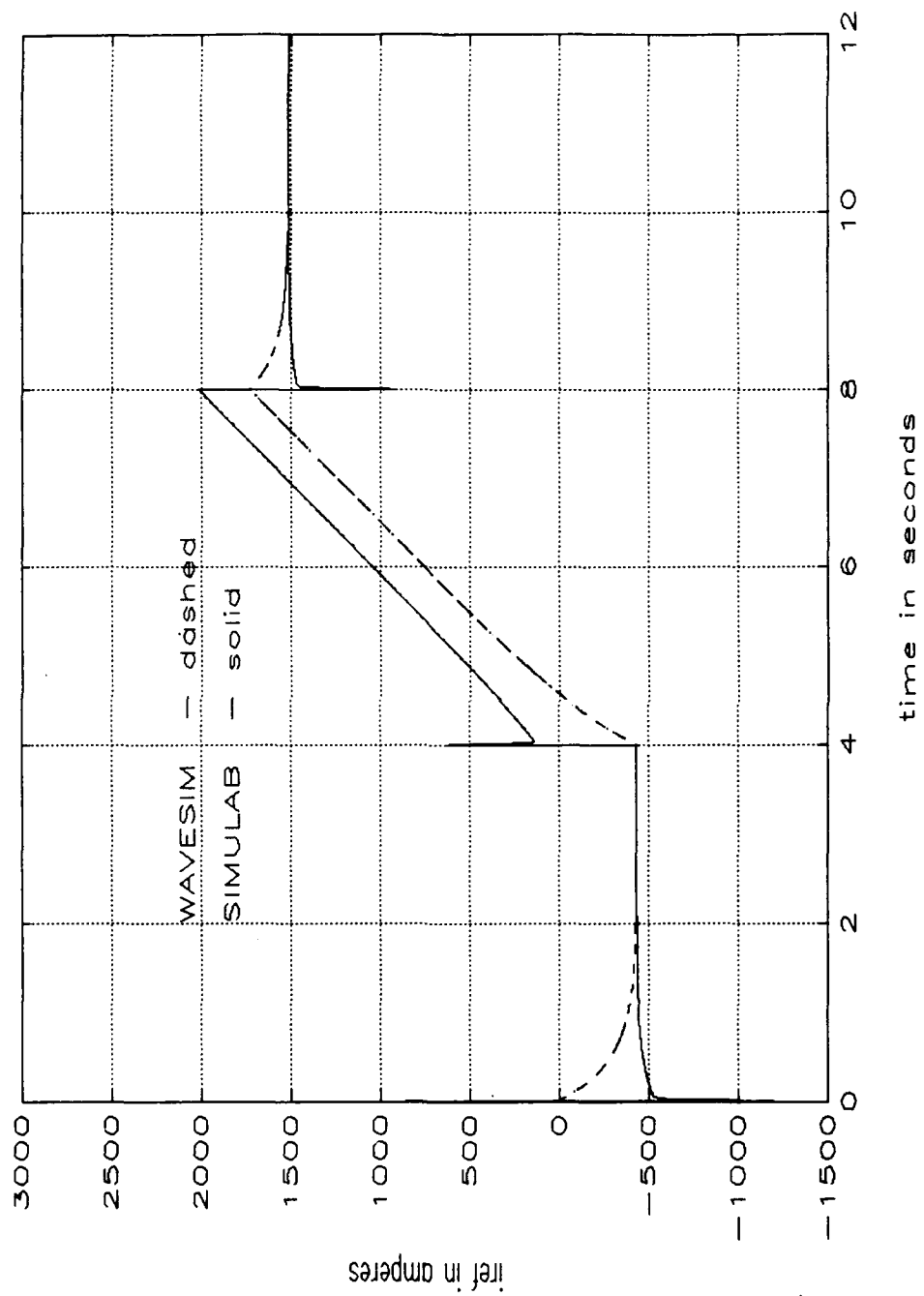

Figure 23 Speed regulator response to a pulse disturbance

TABLE III SPEED REGULATOR RESPONSE TO A PULSE DISTURBANCE				
	Initial steady state	Final steady state	Maximum I_{ref}	Minimum I_{ref}
WAVESIM	-411 A	1528 A	1740 A	-411 A
SIMULAB	-433 A	1513 A	2536 A	-1197 A

At this point, an analytic verification of the results is required to determine whether SIMULAB or WAVESIM is in error. Two cases are derived:

- $\omega_m = \omega_{ref}$
- $\omega_m \neq \omega_{ref}$

For the block diagram of the speed regulator given in Fig. 9 the analytic solution may be determined by taking the inverse Laplace transform of the given transfer functions using partial fraction expansion. For the case of $\omega_m = \omega_{ref} = 188.5$ the analytic solution in the time domain is:

$$i_{ref}(t) = 24344e^{-200t} - 21272e^{-165t} - 104e^{-2.22t} - 433 \quad (49)$$

Figure 24 shows the simulation results of WAVESIM and SIMULAB superimposed with the analytic result for the conditions given for (48). Note that SIMULAB agrees exactly with the analytic solution. The analytic expression for $i_{ref}(t)$ when $\omega_{ref} = 188.5$ rad/sec and $\omega_m = 94.25$ rad/sec is given by:

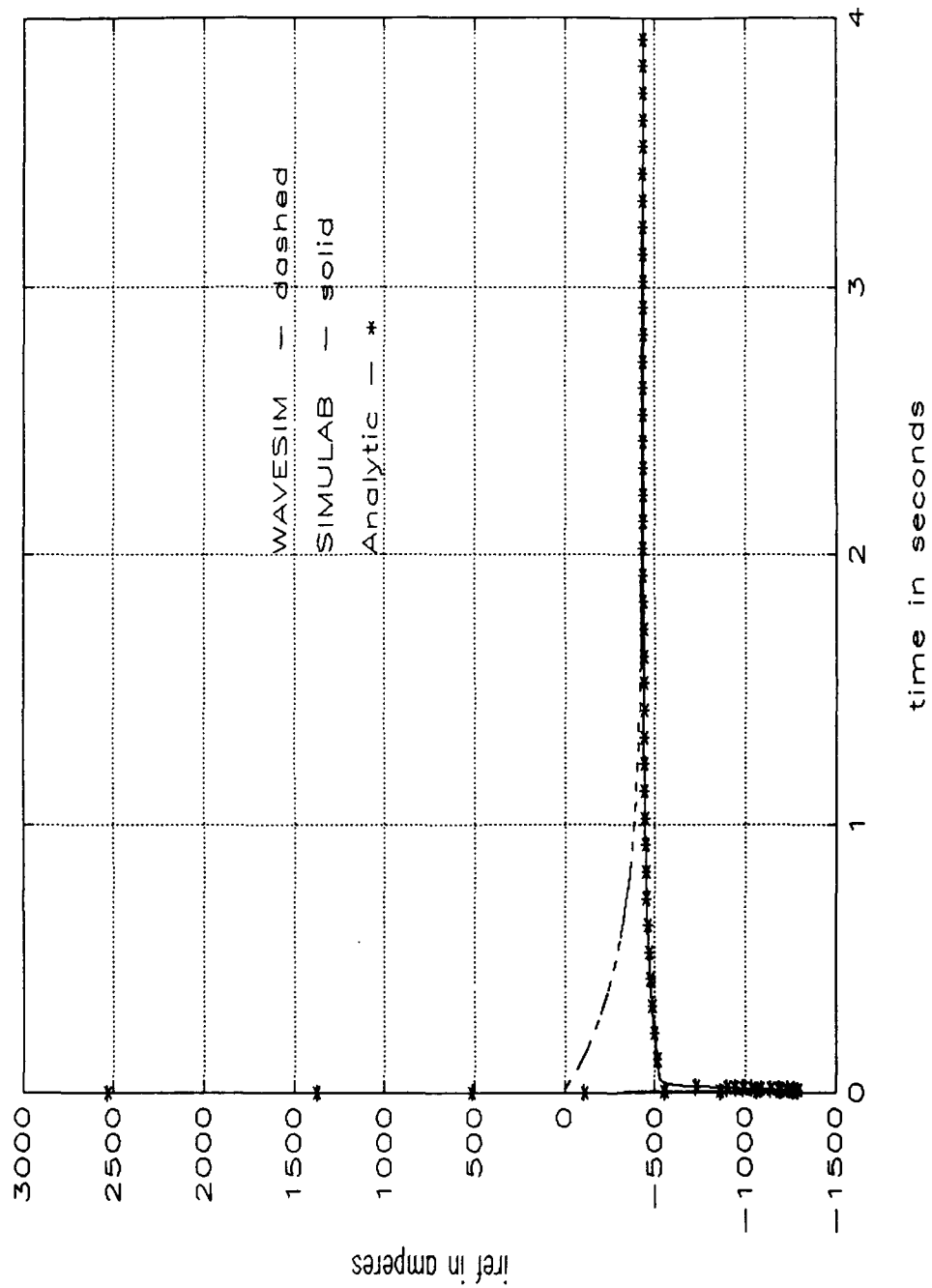

Figure 24 Comparison of solution methods for the speed regulator response to a step input with $\omega_{ref} = \omega_m$

$$i_{ref}(t) = 12100e^{-200t} - 9600e^{-165t} - 52e^{-2.22t} + 486.5t + 67 \quad (50)$$

Figure 25 shows plots of (49), WAVESIM, and SIMULAB results under the same conditions. Once again the SIMULAB output essentially matches the analytic solution while WAVESIM yields inaccurate results for the transient response.

The analytic results expressed in (48) and (49) do not include the amplifier limiter shown in Fig. 9. The SIMULAB models used include this feature. One may infer that since the SIMULAB results exactly match the analytic results, the limiter does not affect these particular simulations.

2. Current Regulator

The block diagram for the current regulator is given in Fig. 10 of Chapter IV. The parameters for this device as given by Mayer are [14]:

- $C_1 = 4.107 \times 10^{-3}$ V/A
- $K_1 = 0.452$
- $K_{i1} = 2.159$
- $K_{i2} = 71.45$
- $K_{i3} = 5.076 \times 10^{-5}$
- $\tau_{i1} = 6.8 \times 10^{-3}$ seconds
- $\tau_{i2} = 1.8 \times 10^{-3}$ seconds
- $\tau_{i3} = 7.3 \times 10^{-3}$ seconds

The simulation is conducted with $i_{ref} = 1000$ Amperes. The motor current is given by:

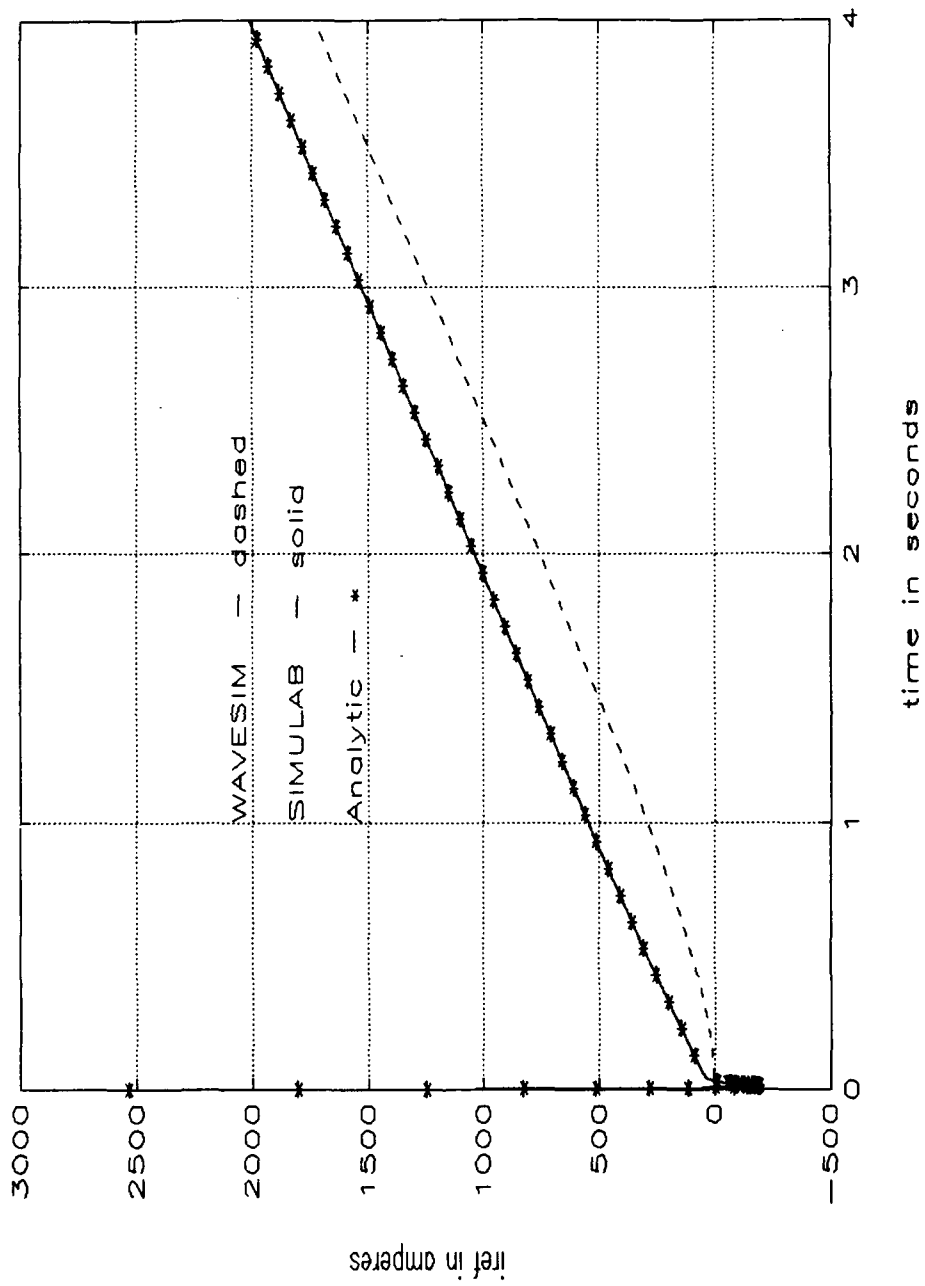

Figure 25 Comparison of solutions for speed regulator response to a step input with $\omega_{ref} \neq \omega_m$

$$i_m = \begin{cases} 1000 \text{ amperes} & t < .2 \text{ seconds} \\ 800 \text{ amperes} & .2 < t < .4 \text{ seconds} \\ 1000 \text{ amperes} & .4 < t \text{ seconds} \end{cases} \quad (51)$$

The minimum time increment allowed is 1 μ sec and the maximum is 500 μ sec. Figure 26 is a plot of the WAVESIM and SIMULAB results. The WAVESIM solution completely misses the transients caused by the step changes in input. Further, the steady state values of the terminal voltages disagree by 7.9 volts. Table IV highlights the information shown in Fig. 26.

TABLE IV RESPONSE OF THE CURRENT REGULATOR TO A PULSE DISTURBANCE				
	Initial steady state	Final steady state	Maximum V_m	Minimum V_m
WAVESIM	0 v	11.45 v	11.45 v	0 v
SIMULAB	-7.83 v	3.62 v	5.47 v	-7.83 v

Analytic solutions for the current regulator response to two input conditions are given in (50) and (51). For the case of $i_m = i_{ref} = 1000$ amperes the current regulator response is

$$v_m(t) = 7.1e^{-555.6t} + .71e^{-137.0t} - 7.83 \quad (52)$$

For the case of $i_{ref} = 1000$ amperes and $i_m = 800$ amperes the current regulator response is

$$v_m(t) = 5.4e^{-555.6t} + .57e^{-137.0t} + 57.3t - 6 \quad (53)$$

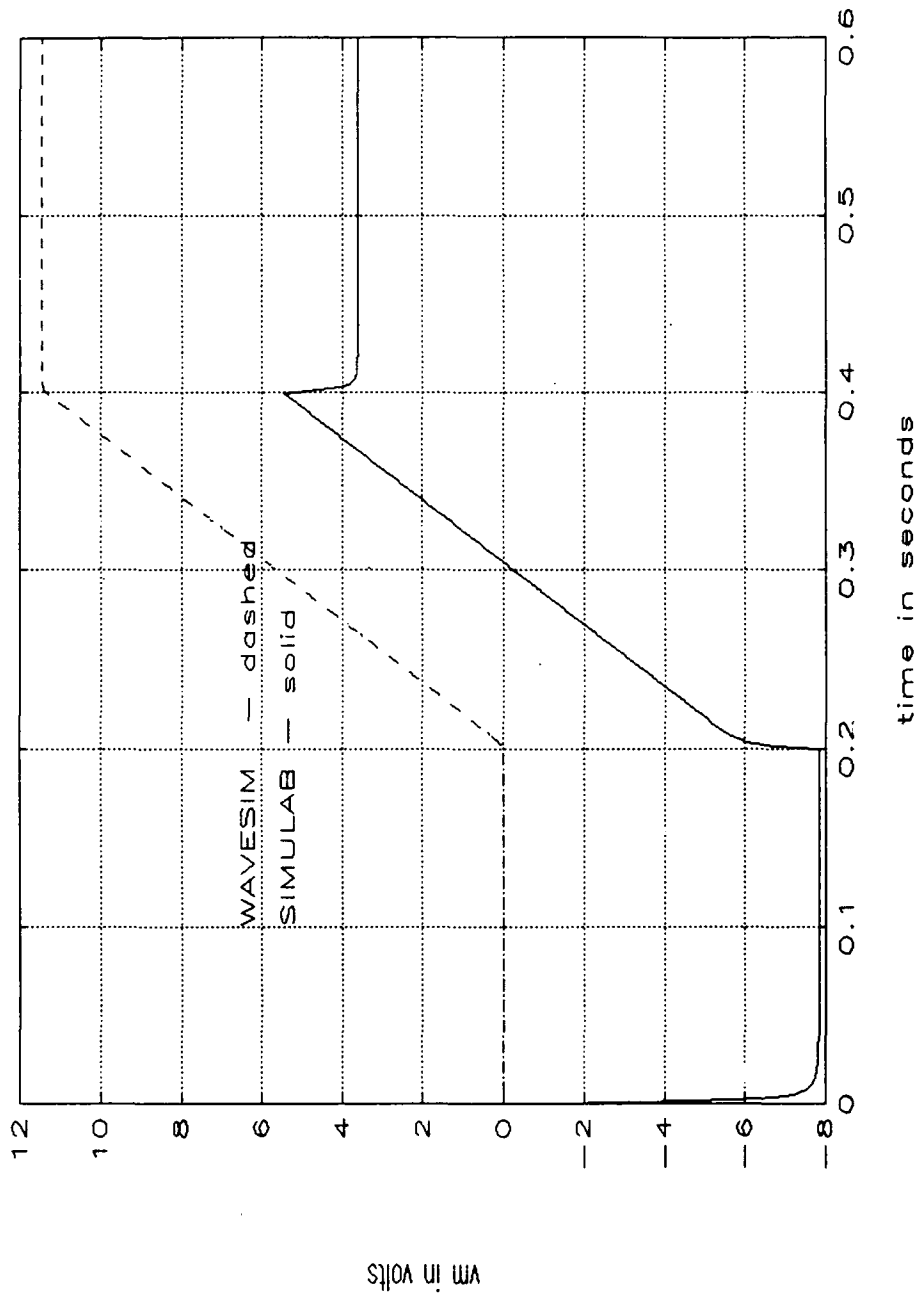

Figure 26 Current regulator response to a pulse disturbance

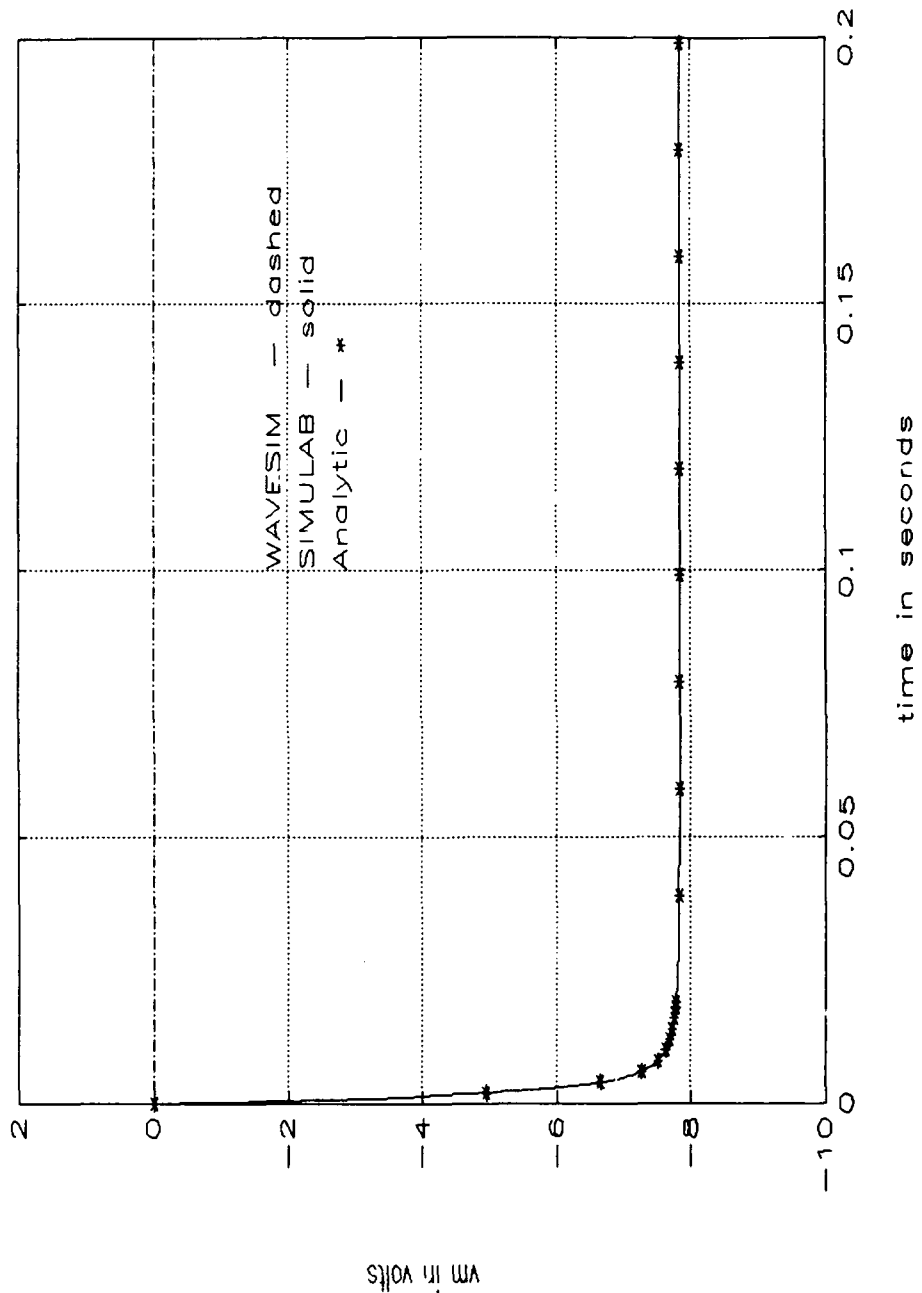

Figure 27 Comparison of results for current regulator response to a step input with $i_{ref}=i_m$

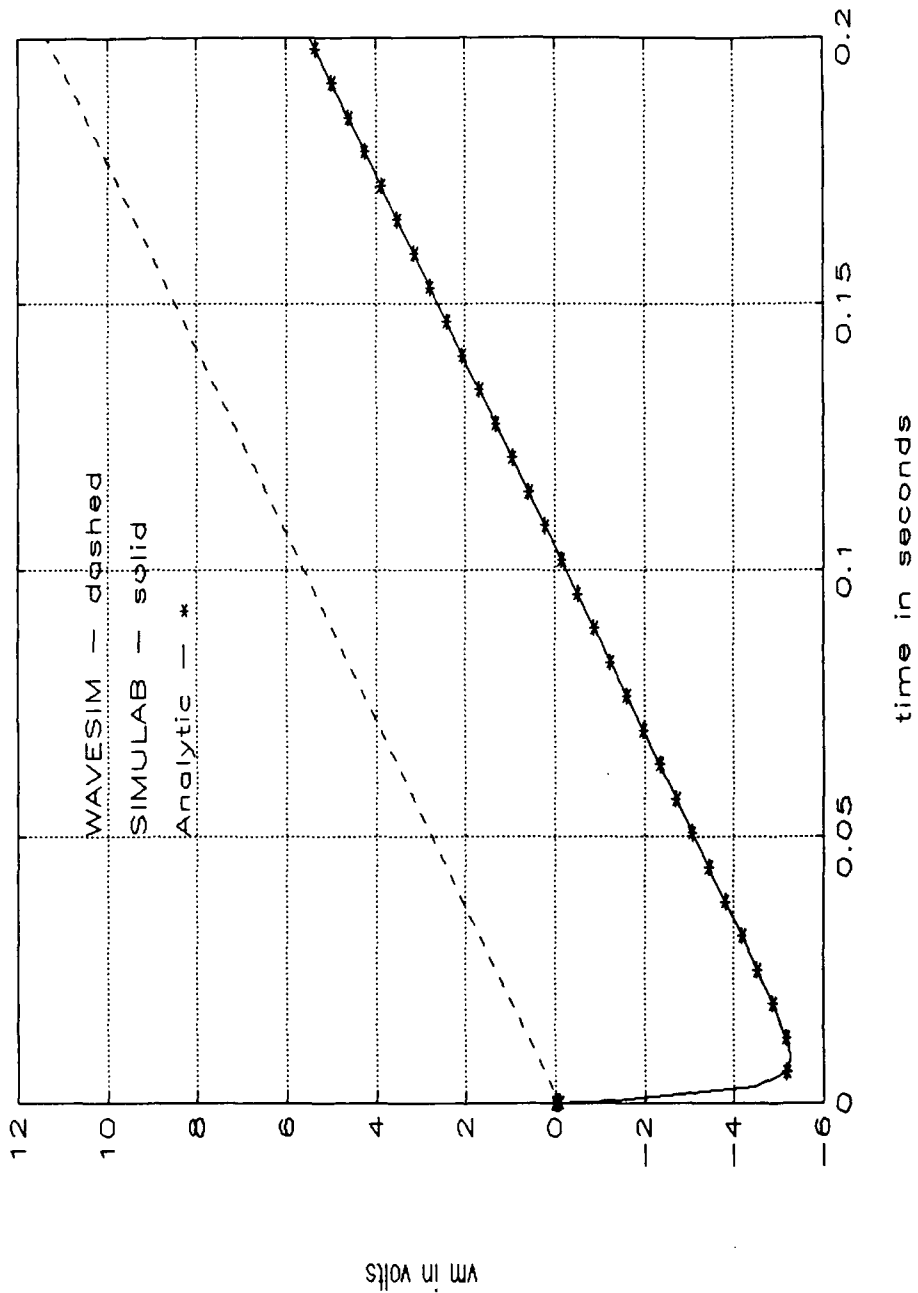

Figure 28 Comparison of results for current regulator response to a step input with $i_{ref} \neq i_m$

Figures 27 and 28 are plots of (52) and (53) respectively superimposed on the SIMULAB and WAVESIM results for the same conditions. Once again there is exact agreement between SIMULAB and the analytic result and a lack of agreement between WAVESIM and the analytic result.

3. DC Motor

The DC motor of the turbine emulator is rated at 800 hp, 500 volts and 1750 rpm. The block diagram for the motor is shown in Fig. 11 of Chapter IV. The parameters for this machine as given by Mayer are [21]:

- $r_a = 4.18 \times 10^{-3} \Omega$
- $L_a = .111 \text{ Mh}$
- $\tau_a = L_a / r_a = .266 \text{ ms}$
- $K_v = 2.487 \text{ V*s/rad}$
- $K_i = 1.769 \text{ ft*lb/A} = 2.4 \text{ N*m/A}$

The analytic expression for this model is

$$i_m(t) = \frac{err}{r_a} - e^{-\left(\frac{err}{r_a}\right)t} \quad (54)$$

where

$$err = v_{ref} - K_v * \omega_m \quad (55)$$

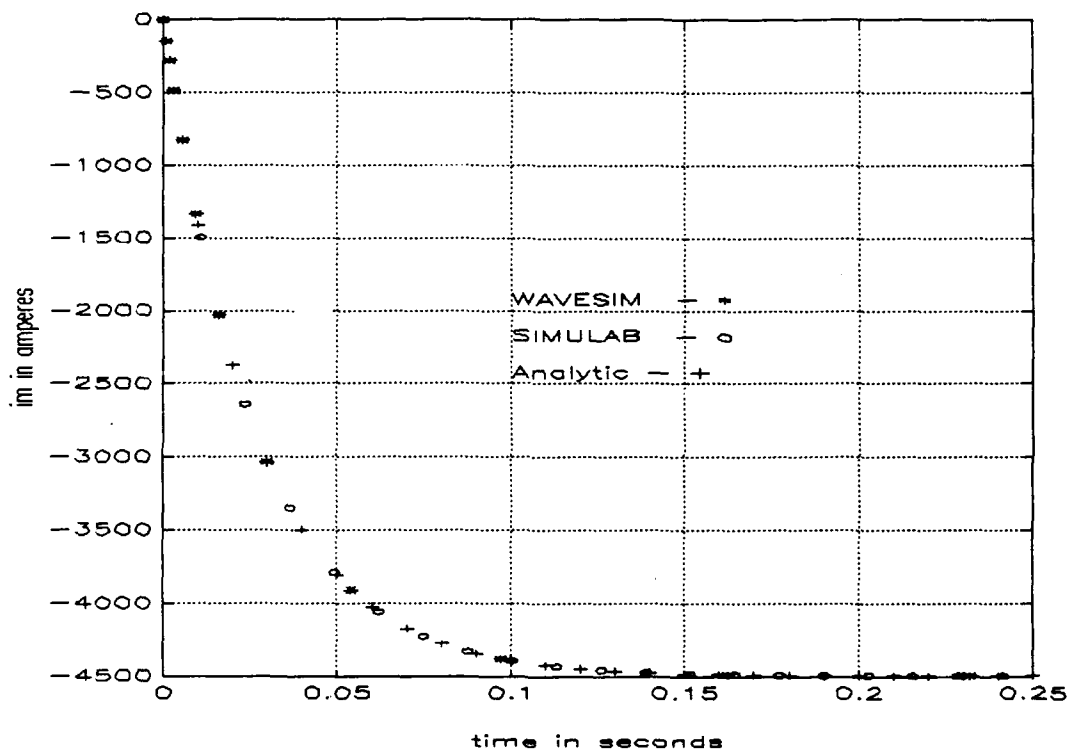

Figure 29 Comparison of DC motor simulations with $\omega_m=188.5$ rad/sec and $v_m=450$ volts

Figure 29 is a plot of the SIMULAB, WAVESIM and analytic solutions for $\omega_m=188.5$ and $v_m=450$ volts. All three methods agree.

4. Combined Elements of the Turbine Emulator

Figure 30 shows the simulation results for the overall turbine emulator simulation. For this simulation the speed regulator, the current regulator and the DC motor are connected according to Fig. 8. The dynamic response of the motor current was simulated with $\omega_{ref}=188.5$ and ω_m as follows:

$$\omega_m = \begin{cases} 188.5 & t < .8 \text{ seconds} \\ 94.25 & .8 < t < 1.6 \text{ seconds} \\ 188.5 & 1.6 < t \text{ seconds} \end{cases}$$

The nature of the response given by WAVESIM is completely different than the response given by SIMULAB. Table V highlights the data presented in Fig. 30.

TABLE V RESPONSE OF THE TURBINE EMULATOR TO A PULSE DISTURBANCE				
	Initial steady state	Final steady state	Maximum motor current	Minimum motor current
WAVESIM	-343.9 A	.72 A	37798 A	-87837 A
SIMULAB	-453.7 A	-54.1 A	15945 A	-35337 A

An interesting problem occurred when executing this simulation. The initial attempt to conduct the simulation set the maximum time increment to 100 ms and the minimum time increment to 1 ms. With these time controls the program

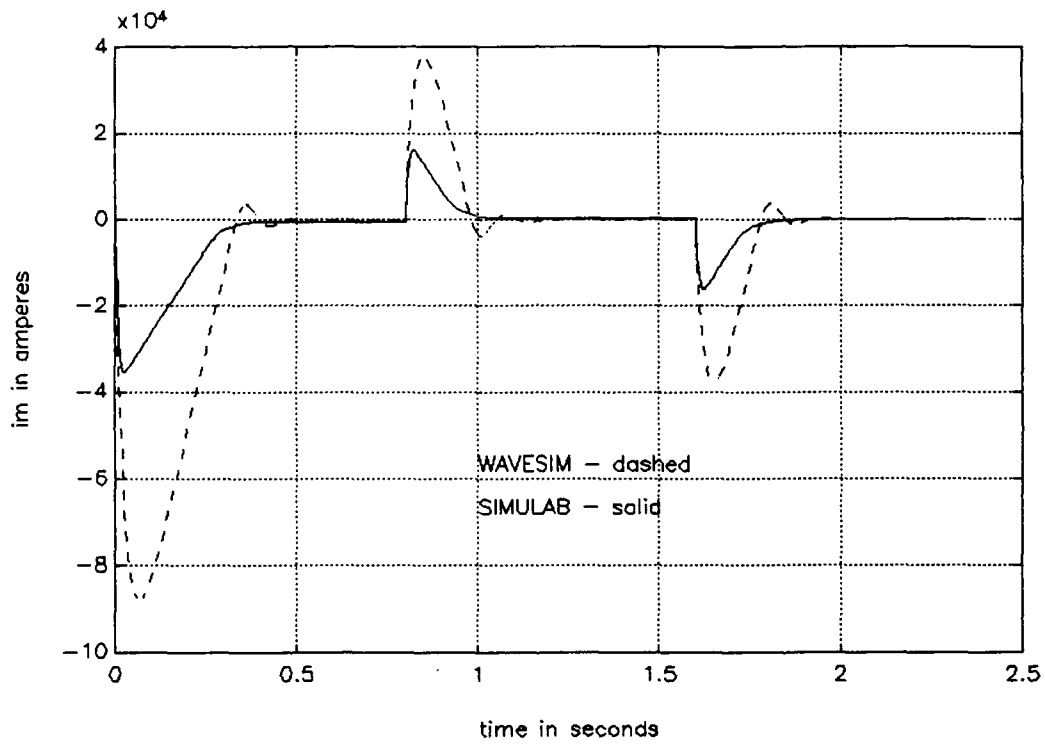

Figure 30 Turbine emulator response to a pulse disturbance

failed to converge to a solution and decremented the continuation parameter to zero. At this point the simulation entered an apparently infinite loop (ran without progress for 24 hours) returning the converge failure warning. The problem was avoided by changing the maximum allowable time step to 10 ms which resulted in successful convergence to a solution (albeit a questionable solution).

The flow charts given in Figs. 21 and 22 show that, if a block fails to converge and α is too small, either the ending value of the time interval should be updated such that the time interval length is reduced or the number of coefficients is increased in order to decrease the truncation error. This did not happen in the above instance. Once alpha was decremented to zero, the program continued attempting to converge changing neither the time interval nor the number of coefficients apparently never leaving the "solve blocks" portion of Fig. 21.

5. Voltage Regulator

The block diagram for a voltage regulator is given in Fig. 12 of Chapter VI. The parameters for this device as given by Mayer are [14]:

- $K_E=1$
- $K_A=200$
- $K_F=0.3$
- $\tau_A=0.02$ seconds

- $\tau_{f1}=0.15$ seconds
- $\tau_{f2}=0.04$ seconds
- $A=0.09826$
- $B=0.33876$

The test was conducted with $v_{ref}=1$ per unit. The terminal voltage was input as

$$v_t = \begin{cases} .8 \text{ pu} & t < 10 \text{ seconds} \\ 1.2 \text{ pu} & t > 10 \text{ seconds} \end{cases}$$

Figure 31 shows the results of this simulation. The voltage regulator begins to saturate at about 3.1 volts and is fully saturated at 3.3 volts. There is general agreement between SIMULAB and WAVESIM during the initial phase of the simulation with the two agreeing exactly on the voltage at saturation. However, when the terminal voltage is stepped to 1.2 per unit there is delay in the response predicted by WAVESIM of over three seconds.

6. Conclusions on Modelling the Turbine Emulator

The preceding sections documented efforts to use WAVESIM to model the turbine emulator as presented in Chapter IV. The results were not encouraging. Every effort was made, short of disassembling the models themselves, to achieve results that could be corroborated by SIMULAB. The SIMULAB models were verified against analytic solutions to ensure

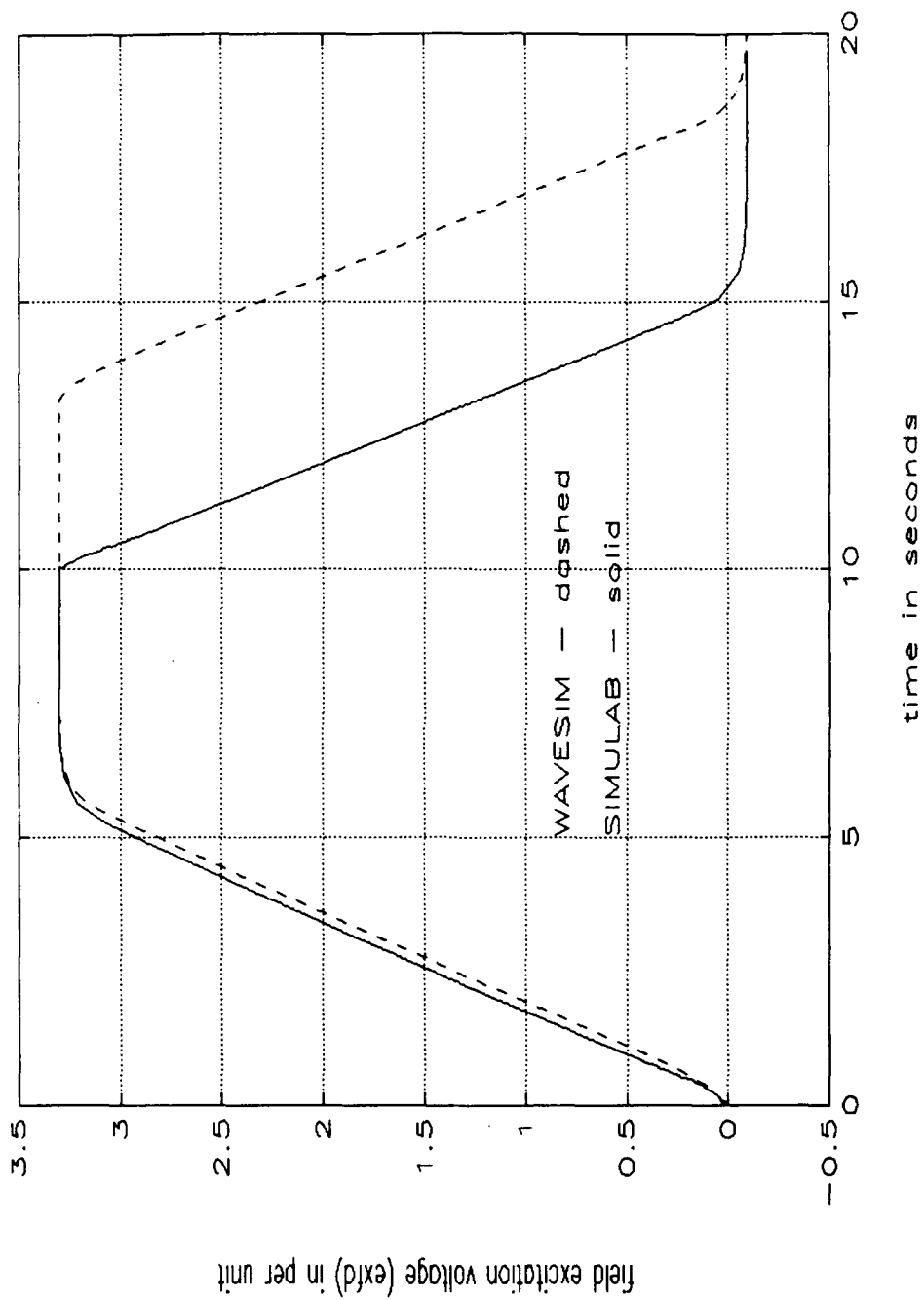

Figure 31 Voltage regulator response to a step change in terminal voltage

their accuracy. In every case, WAVESIM failed to accurately reflect the dynamic performance of the systems being simulated.

C. EVALUATION OF WAVESIM VERSUS THE METRICS IN CHAPTER THREE

1. System and Component Level Modelling Environment

WAVESIM is highly modular. With properly developed models and with adequate accompanying documentation the user could be expected to quickly develop the skills necessary to use the program. This assumes that adequate models have been developed. In its current stage of development the available models are inadequate for virtually any task.

Model development is not intuitive. [21] and [22] detail the steps involved in encoding a three phase synchronous generator. The requirement to cast all relationships into waveform equations is burdensome. The use of waveform equations and special waveform functions to perform even simple arithmetic tasks should be made transparent to the user. The modelling technique requires an intimate knowledge of the internal workings of WAVESIM making it difficult for the person not involved in developing the program to write their own models.

2. Robustness When Simulating Non-Linear or Rapid Switching Topologies

There are inadequate models available to determine if WAVESIM can model widely varying topologies. A very large

proportion of the load on an IED system will be solid-state power converters. Therefore, the ability to conduct detailed modelling of solid state power converters is essential. Yet, the methods used by WAVESIM may be ill suited for this kind of simulation. Doerry notes that there are difficulties modelling discontinuous functions and improved methods of discontinuity prediction are required [1:p.163].

3. Correctness of Solution

WAVESIM uses generally accepted solution methods. However, as a modular program WAVESIM's success is dependent on correct development of component models. WAVESIM is capable of arriving at correct solutions to both linear and nonlinear modelling problems as demonstrated in [1]. Chapter VI of this thesis shows that WAVESIM can also deliver incorrect solutions. A good deal of independent validation is required on all models developed if WAVESIM is to be trusted as a useful simulation tool.

4. Software Domain

Currently, field test data can be used in conjunction with WAVESIM due to the programs dependence on MATLAB. While no method exists to use field test data to drive a particular model, it should be possible to develop an object to support this feature. With its current modular construction and with its use of parameters the ability exists to vary control parameters in support of control system synthesis. However,

the time required to reach a new solution may make this process too time consuming.

5. Implementation Options

WAVESIM is written in standard ANSI C and should, therefore, be highly portable. With its current dependence on MATLAB one may foresee a potential for compatibility problems with future versions of MATLAB.

Long term maintainability is an important issue. WAVESIM is essentially a one man project. While the code is documented (as clearly as C code can be), finding people or preferably an organization qualified and willing to further develop and maintain the program over the long term may be difficult.

6. Ease of Use

WAVESIM is neither intuitive nor particularly user friendly. The file mode of input is difficult to master and the large number of "default" sub commands as described in Chapter V section 5B makes input file development cumbersome. An interactive (preferably graphical) user interface is needed.

It is necessary to specify which system variables are of interest in the input file. Only those system variables specified in the input file *plot* command are available as data series at the conclusion of the simulation. Specifying more

system variables for output than required is costly in terms of both simulation time and memory usage.

7. Software Speed Versus System Complexity

While only relatively simple systems were used for this thesis, it is apparent that execution of the simulation file within MATLAB is slow. The simulations conducted for this chapter were conducted on a Sun Sparc Station II running Open Windows version 2 and PROMATLAB version 3.51. It was common for WAVESIM simulations to require a number of hours. The SIMULAB simulations, with the same error tolerances and identically defined time steps, took less than three minutes (usually much less). The simulation of the turbine emulator presented in section B4 of this chapter required 41 minutes for WAVESIM to complete and only 3 seconds for SIMULAB to complete. A more telling comparison is that WAVESIM required 969.6 million floating point operations (MFLOPS) to complete the simulation while SIMULAB required only 25800 floating point operations for the turbine emulator simulation.

8. Continued Support

As discussed in section B5 of this chapter, long term maintainability is a primary consideration in choosing a software tool. WAVESIM is basically the result of a very small group of people who are no longer with the institution at which the program was developed. While WAVESIM is of

interesting academic value, it no longer has the support
necessary to make it into a useful tool.

VIII CONCLUSIONS

A. NEED

The Navy has a definite requirement for a simulation for use in developing and studying advanced marine power systems. This need is brought about primarily due to the pending shift from the traditional engineering plant configuration of separate propulsion and electrical systems to an advanced marine power system integrating propulsion and power generating prime movers.

The simulation program must meet the requirements enumerated in Chapter IV. Specifically it must be:

- modular and have an adequate model library
- robust and capable of simulating rapidly switching topologies associated with large, solid-state power converters
- capable of providing correct dynamic and steady state performance data
- portable and maintainable
- easy to use
- fast and capable of solving stiff systems of equations
- well supported

B. ANALYSIS OF WAVESIM

WAVESIM introduces and combines advanced simulation techniques in an effort to develop a simulation tool specifically tailored to modelling advanced marine power systems. The result has been a test program that demonstrates these methods but in its current state is not useful as an actual tool. This conclusion is based on the metrics presented in Chapter IV and on the evaluation of WAVESIM as presented in Chapter VII.

C. FUTURE WORK

1. WAVESIM

Additional testing of WAVESIM including detailed analysis of previously developed models, investigating why the dynamic performance of the given models does not match the analytic results, and developing new models are areas of future work. Further, investigation of methods of discontinuity prediction, improved numerical efficiency, and removal of the dependence on MATLAB, as well as developing an online user interface are areas of future work if Navy interest remains in improving WAVESIM.

2. Other programs

The usefulness of two commercially available programs mentioned previously in this thesis warrant further investigation. ACSL introduced in Chapter II section D.3.a has been used for both component and system level modelling of

power systems at Purdue University [6]. SIMULAB was shown in Chapter VII to accurately model the components of the turbine emulator. ACSL research is currently underway at Purdue.

SIMULAB meets many of the requirements given in Chapter III for a simulation tool. It is modular and allows for the modelling of both linear and non-linear devices. It is commercially supported. It is fast and efficient allowing various integration methods to be specified depending on the nature of the system being modelled. Lastly, it is intuitive in that it uses a graphical user interface displaying actual transfer functions for the various blocks. Investigation of SIMULAB to meet the need of a power systems simulation tool may be a worthwhile project.

LIST OF REFERENCES

- [1] Doerry, N.H., *Advanced Numerical Methods for Simulating Nonlinear Multirate Lumped Parameter Models*, Ph.D. Dissertation, Massachusetts Institute of Technology, Cambridge, MA, May 1991.
- [2] Propulsion Plant Guide for USS WORDEN (CG 18).
- [3] "Advanced Electrical Distribution System", Notes provided by H. Hegner, DTRC Electrical Systems Division, 18 March, 1992.
- [4] Ilic, M. and Kirtley, J.L. Jr., "Analysis and Control of Shipboard Integrated Electric Power Systems", proposal to The Office of Naval Research, Massachusetts Institute of Technology Department of Ocean Engineering, 11 May 1987.
- [5] Meeting notes from June 16, 1992 WAVESIM progress meeting between David Taylor Research Center (H. Hegner), MIT Department of Electrical Engineering (Dr. J.L. Kirtley), and the Naval Postgraduate School (Dr. S. Williams), and NAVSEA 05Z (LT. Doerry).
- [6] Meeting notes from "ASMS Open Architecture" meeting 08 November, 1991. David Taylor Research Center.
- [7] Hultgren, Kenneth J., "VSCF Cycloconverter Ships Service Power Equipment", *Naval Engineers Journal*, January 1992.
- [8] Krause, Paul C., "Final Report on Modeling of Shipboard Electric Power Distribution System", for David Taylor Research Center, SBIR Phase I Contract No. N00167-88-C-0031, P.C. Krause and Associates, Inc., West Lafayette, IN, July 1988.
- [9] Krause, Paul C., "Krause, Paul C. and Wasynczuk, O., "Development of Computer Models to Analyze Shipboard Electrical Power Systems", Final Report, Contract No. N61533-89-D-0037, School of Electrical Engineering, Purdue University, West Lafayette, IN, October, 1990.

- [10] Doerry, N.H., *Advanced Numerical Methods for Simulating Nonlinear Multirate Lumped Parameter Models*, proposal for Ph.D. Research, Department of Ocean Engineering at Massachusetts Institute of Technology, Cambridge, Massachusetts, 19 November 1990.
- [11] Doerry, N.H., *Waveform Simulation of Nonlinear Lumped Parameter Systems*, Ph.D. Research Progress Report, Department of Ocean Engineering at Massachusetts Institute of Technology, 29 November, 1990.
- [12] David Taylor Research Center, DTRC 2753, *Naval Submarine Power Systems Simulation Requirements & EMTP*, by Ed Zivi, 05 April, 1991.
- [13] "Excitation System Models for Power System Stability Studies", IEEE Committee Report, *IEEE Transactions of Power Apparatus and Systems*, v. PAS-100, no. 2 Feb. 1981.
- [14] Mayer, C.B., "Digital Computer Simulation Program for Turbine Emulator Drive and Load System", Report of Contract N00167-85-C-0131. May 13, 1987.
- [15] Kirtely, J.L Jr., "Synchronous Machine Dynamic Models", LEES Technical Report TR-87-008, June 5, 1987.
- [16] Krause, Paul C. and Wasynczuk, Oleg, *Electromechanical Motion Devices*, McGraw-Hill, Inc., 1989.
- [18] Krause, Paul C., *Analysis of Electric Machinery*, McGraw-Hill, Inc., 1987.
- [19] "Computer Representation of Excitation Systems", IEEE Committee Report, *IEEE Transactions of Power Apparatus and Systems*, v. PAS-87, no. 6, June 1968.
- [20] Mohan, N., Undeland, T.M., and Robbins, W.P., *Power Electronics Converters, Applications, and Design*, John Wiley & Sons, Inc., 1989.
- [20] Glover, J.D. and Sarma, M., *Power System Analysis and Design*, PWS-Kent Publishing Company, 1989.

- [21] Amy, John and Tolikas, Mary. "Report on the Development of a 3-Phase Synchronous Machine Device Object for Use Within WAVESIM", Massachusetts Institute of Technology, Department of Ocean Engineering and Computer Science. Aug. 13, 1991.
- [22] Amy, John and Tolikas, Mary. "Follow-up Report on the Development of a 3-Phase Synchronous Machine Device Object for Use Within WAVESIM", Massachusetts Institute of Technology, Department of Ocean Engineering and Computer Science. May, 1992.

INITIAL DISTRIBUTION LIST

1. Defense Technical Information Center 2
Cameron Station
Alexandria, VA 22304-6145
2. Library, Code 52 2
Naval Postgraduate School
Monterey, CA 93943-5002
3. Chairman, Code EC 1
Department of Electrical and Computer Engineering
Naval Postgraduate School
Monterey, CA 93943-5000
4. Professor Stephen M. Williams, Code EC/WL 1
Department of Electrical and Computer Engineering
Naval Postgraduate School
Monterey, CA 93943-5000
5. Professor Monique P. Fargues, Code EC/FA 1
Department of Electrical And Computer Engineering
Naval Postgraduate School
Monterey, CA 93943-5000
6. David Taylor Research Center 1
Attn: Henry Hegner
Annapolis Lab (Code 2714)
Annapolis, MD 21402-5067
7. David Taylor Research Center 1
Attn: David Clayton
Annapolis Lab (Code 2714)
Annapolis, MD 21402-5067
8. David Taylor Research Center 1
Attn: Ed Zivi
Annapolis Lab (Code 2753)
Annapolis, MD 21402-5067
9. David Taylor Research Center 1
Attn: Ralph Youngs
Annapolis Lab (Code 2753)
Annapolis, MD 21402-5067
10. Commanding Officer 1
Naval Sea Systems Command (Code 05D)
Washington, D.C.20362-5101

11. Commanding Officer 1
Naval Sea Systems Command (Code 05E)
Washington, D.C.20362-5101

12. LT Paul Brochard 1
3220 Freese Ave.
Eureka, CA 95501