



Calhoun: The NPS Institutional Archive

Faculty and Researcher Publications

Faculty and Researcher Publications

1998

Analytical Redundancy and Fuzzy Inference in AUV Fault Detection and Compensation

Healey, A. J.

Healey, A. J., "Analytical Redundancy and Fuzzy Inference in AUV Fault Detection and Compensation", Proceedings Oceanology 1998, Brighton, March 11-14, 1998 pp.45-50



Calhoun is a project of the Dudley Knox Library at NPS, furthering the precepts and goals of open government and government transparency. All information contained herein has been approved for release by the NPS Public Affairs Officer.

Dudley Knox Library / Naval Postgraduate School
411 Dyer Road / 1 University Circle
Monterey, California USA 93943

<http://www.nps.edu/library>

Analytical Redundancy and Fuzzy Inference in AUV Fault Detection and Compensation

A. J. Healey
Professor and Director
Center for AUV Research
Naval Postgraduate School
Monterey, CA 93953

healey@me.nps.navy.mil

<http://web.nps.navy.mil/~me/healey.html>

ABSTRACT

This paper will address the results of a recent study developing model based techniques using analytical redundancy in the production of observation residuals that are processed for the on-line, real time detection of dynamic faults during the operation of AUVs. AUVs are being developed for oceanographic survey, as well as military, missions. Now that underwater navigation to sufficient precision within cost limits is possible, the remaining technical issue is to improve the reliability of the mission completion. Increasing mission reliability implies many things-some having nothing to do with automatic fault detection. However, assuming that the vehicle is equipped with highly reliable sensor suites, connections, and computing components, it is of interest to see if unexpected faults could be detected reliably so that system reconfiguration could be accomplished to allow missions to be continued in some fashion.

A survey of fault detection methods indicates that alarms can be easily monitored if signals are static. This is done using 'limits and trends' analysis with thresholds set for various levels of severity. With dynamic signals, such as those induced by an actuator fault in the form of a stuck fin, or a loose fin, or fouling of a propeller, the transient nature of the signal makes limits and trends analysis invalid. In these cases, signals are sought that include servo error, and the residual error in observation filters. Designing observation filters builds analytical redundancy into the decision making. Additionally, since there is always the difficulty of separating the fault response from disturbance response, operation near the surface under waves requires the development of a wave detector.

A fault detection architecture is proposed that is based on using simple detection circuits that look for fault signal magnitude as well as length of time persisting in the fault mode that produces the fault declaration. Adjustments in the threshold parameters are able to distinguish between wave disturbance and fault condition.

The architecture allows for the recommended accommodation response using a fuzzy inference system linking residual fault declaration signals as inputs that are mapped to recommended actions using fuzzy rules.

Example responses are discussed, and in particular, the fault detection and accommodation due to loss of control at low speed under wave action with stuck fins, is given.

INTRODUCTION

Long term deployments of autonomous systems in the ocean require replenishment of energy supplies and reliable, fault free operation. It is recognized that fault free operation will not always be

Report Documentation Page

Form Approved
OMB No. 0704-0188

Public reporting burden for the collection of information is estimated to average 1 hour per response, including the time for reviewing instructions, searching existing data sources, gathering and maintaining the data needed, and completing and reviewing the collection of information. Send comments regarding this burden estimate or any other aspect of this collection of information, including suggestions for reducing this burden, to Washington Headquarters Services, Directorate for Information Operations and Reports, 1215 Jefferson Davis Highway, Suite 1204, Arlington VA 22202-4302. Respondents should be aware that notwithstanding any other provision of law, no person shall be subject to a penalty for failing to comply with a collection of information if it does not display a currently valid OMB control number.

1. REPORT DATE

2005

2. REPORT TYPE

3. DATES COVERED

-

4. TITLE AND SUBTITLE

Analytical Redundancy and Fuzzy Inference in AUV Fault Detection and Compensation

5a. CONTRACT NUMBER

5b. GRANT NUMBER

5c. PROGRAM ELEMENT NUMBER

6. AUTHOR(S)

5d. PROJECT NUMBER

5e. TASK NUMBER

5f. WORK UNIT NUMBER

7. PERFORMING ORGANIZATION NAME(S) AND ADDRESS(ES)

**Naval Postgraduate School, Center for AUV
Research, Monterey, CA, 93943-5000**

8. PERFORMING ORGANIZATION
REPORT NUMBER

9. SPONSORING/MONITORING AGENCY NAME(S) AND ADDRESS(ES)

10. SPONSOR/MONITOR'S ACRONYM(S)

11. SPONSOR/MONITOR'S REPORT
NUMBER(S)

12. DISTRIBUTION/AVAILABILITY STATEMENT

Approved for public release; distribution unlimited

13. SUPPLEMENTARY NOTES

The original document contains color images.

14. ABSTRACT

This paper will address the results of a recent study developing model based techniques using analytical redundancy in the production of observation residuals that are processed for the on-line, real time detection of dynamic faults during the operation of AUVs. AUVs are being developed for oceanographic survey, as well as military, missions. Now that underwater navigation to sufficient precision within cost limits is possible, the remaining technical issue is to improve the reliability of the mission completion. Increasing mission reliability implies many things-some having nothing to do with automatic fault detection. However, assuming that the vehicle is equipped with highly reliable sensor suites, connections, and computing components, it is of interest to see if unexpected faults could be detected reliably so that system reconfiguration could be accomplished to allow missions to be continued in some fashion. A survey of fault detection methods indicates that alarms can be easily monitored if signals are static. This is done using 'limits and trends' analysis with thresholds set for various levels of severity. With dynamic signals, such as those induced by an actuator fault in the form of a stuck fin, or a loose fin, or fouling of a propeller, the transient nature of the signal makes limits and trends analysis invalid. In these cases, signals are sought that include servo error, and the residual error in observation filters. Designing observation filters builds analytical redundancy into the decision making. Additionally, since there is always the difficulty of separating the fault response from disturbance response, operation near the surface under waves requires the development of a wave detector. A fault detection architecture is proposed that is based on using simple detection circuits that look for fault signal magnitude as well as length of time persisting in the fault mode that produces the fault declaration. Adjustments in the threshold parameters are able to distinguish between wave disturbance and fault condition. The architecture allows for the recommended accommodation response using a fuzzy inference system linking residual fault declaration signals as inputs that are mapped to recommended actions using fuzzy rules. Example responses are discussed, and in particular, the fault detection and accommodation due to loss of control at low speed under wave action with stuck fins, is given.

15. SUBJECT TERMS

16. SECURITY CLASSIFICATION OF:

a. REPORT

unclassified

b. ABSTRACT

unclassified

c. THIS PAGE

unclassified

17. LIMITATION OF ABSTRACT

18. NUMBER OF PAGES

6

19a. NAME OF RESPONSIBLE PERSON

possible, so that system design must pay attention to a study of failure modes and their effects. In spite of the use of good engineering practice, faults can occur. Two kinds of 'faults' identified are,

- 1) those that arise from malfunctions in the hardware and software subsystems in the vehicle,
- 2) those that arise from environmental conditions that are viewed as disturbances, and while these may not be directly 'faults', they have the effect that the completion of a mission is jeopardized.

An example of a hardware fault would be the loss of steering resulting from a stuck or loose fin. An example of a type 2 fault would be the inability of the vehicle to take a data measurement because of high sea state in shallow water operation.

To design a system that will automatically detect the presence of a 'fault' is the subject of many papers. This problem is common to the aircraft, spacecraft, and process industries, and much has been written about methods available. In general we can classify the methods into those that use simple limits and trends analysis, those that use detection techniques but which are without the use of analytical models, and those that provide analytical models as the basis for detection filters [1,2]. The detection of status signals such as battery voltage, motor winding temperature, computer bay temperatures, is relatively easy and accomplished by the comparison of the measured signal with a previously set threshold. Exceeding those thresholds would indicate a fault condition for which some action is taken – for instance either to slow down the vehicle speed or to abort the mission and surface. It is more difficult to detect those faults that give rise to dynamic signals such as sudden changes in pitch rate that are caused by actuator faults where some form of model free, or model based residual generation must be included.

Model Free Detection

Threshold detection is appropriate when the signals are static or slowly varying and such that a single exceedence means that a fault will be persistent for the remainder of the voyage. Such methods are not suitable for dynamic signals that could arise for instance from seaway wave action. The propensity of dynamic signals to exceed a threshold but later to come within bounds causes thresholding alone to be a problem. We resort to model free methods where some constant feature of the signal can be extracted and then that feature is compared against the threshold. Such is the case when a spectral analysis is performed on signals and spectral levels in specified frequency bands can be compared against thresholds. This methodology is useful to detect the presence of frequency components in servo error signals caused by wave motion and could be used to identify levels of seaway induced disturbances considered as 'faults'.

Model Based Detection

The overall problem of AUV fault detection is complex. Handling complexity by decomposition, the author recommends limiting the detection of faults to the primary subsystems in the vehicle, including, the speed control, steering, diving, roll control, navigation, powering, and computer subsystems. As far as motion capabilities are concerned the speed, steering, diving, and (if present) active roll control subsystems should be monitored. Faults that impair the capability of these subsystems need to be detected so that control reconfiguration may help to mitigate an unnecessary mission abort. Some graceful degradation of mission could be continued if partial depth control or speed control could be maintained.

Dynamic signals such as those developed by autopilot errors become hard to detect, as errors are naturally large when steering to new commands, yet are small if correct final heading is maintained. Wave motion causes wave period oscillatory motion in servo errors. Model based methods have been found to be useful in detecting dynamic faults. A model-based observer is used to generate a 'residual' between the sensor measured values and that predicted from the model. Faults can arise from a bad sensor as well as a faulty actuator (fin / propeller).

The residual provides a signal that is not sensitive to servo errors caused by command changes, and responds primarily to non ideal loads, disturbances from waves, and sensor signal errors. Analysis of the residuals provides the key to subsystem failures. The diving subsystem of an AUV is analyzed for example.

The diving sub-system dynamics for an AUV may be modeled by the system [3,4, 5].

$$\begin{aligned}\dot{\mathbf{x}}(t) &= [w_r(t), q(t), \dot{q}(t), Z(t)]; u(t) = d_s(t) \text{ with} \\ \dot{\mathbf{x}}(t) &= \mathbf{A}\mathbf{x}(t) + \mathbf{B}u(t) + \mathbf{E}f_a(t) + \mathbf{F}d(t); \\ \mathbf{y}(t) &= \mathbf{C}\mathbf{x}(t) + \mathbf{f}_s(t)\end{aligned}$$

With a high quality inertial system, all state variables are measured with little noise and the output matrix, \mathbf{C} , may considered to be identity. $f_a(t)$, $f_s(t)$ are considered to be added forces caused by fin faults, and sensor errors respectively. In the above, w_r , q , \dot{q} , and Z are the heave velocity of the vehicle relative to the water, the pitch rate, pitch angle, and the depth. \mathbf{B} and \mathbf{E} are the input vectors for the control planes and added forces and moments caused by imbalance of commanded and actual loads on the vehicle, caused by actuator faults and \mathbf{F} is the input vector associated with disturbances from waves and upwelling current. It is important to note that since the relative velocity definition for vehicle states is used, \mathbf{E} and \mathbf{F} are distinct and disturbances from waves and currents can be distinguished from actuator faults.

A model-based observer is used given by

$$\begin{aligned}\hat{\mathbf{x}}(t) &= [\hat{w}_r(t), \hat{q}(t), \hat{\dot{q}}(t), \hat{Z}(t)]; u(t) = d_s(t) \text{ with} \\ \dot{\hat{\mathbf{x}}}(t) &= (\mathbf{A} - \mathbf{K}\mathbf{C})\hat{\mathbf{x}}(t) + \mathbf{B}u(t) + \mathbf{K}\mathbf{y}(t); \\ \mathbf{n}(t) &= \mathbf{y}(t) - \mathbf{C}\hat{\mathbf{x}}(t);\end{aligned}$$

The residuals, $\mathbf{n}(t)$, are the differences between the measured states and the estimates from the observer. It follows that, the state observation error, \mathbf{e}_x is given by,

$$\begin{aligned}\dot{\mathbf{e}}_x(t) &= (\mathbf{A} - \mathbf{K}\mathbf{C})\mathbf{e}_x(t) + \mathbf{E}f_a(t) + \mathbf{F}d(t) + \mathbf{K}\mathbf{f}_s(t); \\ \mathbf{n}(t) &= \mathbf{C}\mathbf{e}_x(t) + \mathbf{f}_s(t)\end{aligned}$$

Unlike state observation, residual generation requires a different balance in the choice of filter gains, \mathbf{K} . Too high a choice leads to the residual being small, dominated by sensor faults and noise. A lower gain set is needed consistent with bandwidth requirements. Of course, stability must be obtained.

The residuals can be analyzed in the frequency domain by,

$$\begin{aligned}\mathbf{n}(s) &= \mathbf{C}(s\mathbf{I} - \mathbf{A}_c)^{-1}\mathbf{E}f_a(s) + \mathbf{C}(s\mathbf{I} - \mathbf{A}_c)^{-1}\mathbf{F}d(s) + \mathbf{C}(s\mathbf{I} - \mathbf{A}_c)^{-1}\mathbf{K}\mathbf{f}_s(s); \\ \mathbf{A}_c &= (\mathbf{A} - \mathbf{K}\mathbf{C})\end{aligned}$$

One observer design (low gain) should therefore find a gain set that maximizes the influence of actuator faults, minimizes the influence of wave disturbance, and the sensor faults, while a second (high gain) observer could be designed to emphasis sensor faults. It is noted that since the direction of \mathbf{E} \neq direction of \mathbf{F} (\mathbf{E} , \mathbf{F} are orthogonal), separation of wave effects and actuator faults is possible. In fact, designing a weight matrix, \mathbf{W} , for the residual detecting actuator faults, the ratio,

$$\left\| \mathbf{W}\mathbf{C}(s\mathbf{I} - \mathbf{A}_c)^{-1}\mathbf{E} \right\| / \left\| \mathbf{W}\mathbf{C}(s\mathbf{I} - \mathbf{A}_c)^{-1}\mathbf{F} \right\|;$$

should be maximized over the frequency ranges appropriate. A method for the maximal decoupling of disturbances from faults using eigenvector assignments is discussed in [6].

SIMULATION RESULTS

Using a model of the US Navy DSRV vehicle [6], running at a forward speed of 6 ft/sec.,

$x' = [w_r, q, Q, Z]$. For a slow forward speed of 6 feet per second, the dynamics and input matrices are,

$$A = \begin{bmatrix} -0.1959 & 1.7097 & -0.000 & 0 \\ 0.0483 & -0.9736 & 0.0000 & 0 \\ 0 & 1 & 0 & 0 \\ 1 & 0 & -6.000 & 0 \end{bmatrix}; B = \begin{bmatrix} -0.7213 \\ -0.3277 \\ 0 \\ 0 \end{bmatrix}$$

In this example, the vehicle is in forward way with a command to dive. The autopilot for depth control may be designed a number of different ways, but here, a sliding mode design is used which yields the control law,

```
delta=-k*x-0.4*sign(inv((s'*B)))*tanh((sig/phi));
if abs(delta)>.4;
    delta=0.4*sign(delta);
end;
```

The placed poles are selected to include a single pole at the origin (required by the method) giving,

$$l = [-0.4, -0.41, -0.42, 0]$$

$$k = [-0.1435 \quad 0.1310 \quad -0.6953 \quad 0]$$

$$s' = [0.0642 \quad -0.6700 \quad -0.7393 \quad 0.0201]$$

The observer gains are found using the Matlab place algorithm to get put the observer poles at real values close to the control poles, at [-0.5, -0.56, -0.53, -0.44]. The solution for K yields,

$$K = \begin{bmatrix} 0.2441 & 1.7097 & 0.0000 & 0.0000 \\ -0.0483 & -0.4736 & 0.0000 & 0.0000 \\ -0.1555 & 1.0000 & 0.5300 & 0.0000 \\ 1.0000 & 0.0000 & -6.0000 & 0.5600 \end{bmatrix},$$

and the fault input matrix is in the same direction as the input matrix, B , $E=B$, while the disturbance from wave velocities appears as an additive input to the last of the state equations, so that $F=[0;0;0;1]$. A quick check shows that perfect disturbance decoupling has been achieved.

At a time given by $t=10$ seconds, an added fault at the stern plane is inserted, on the top of a sinusoidal wave disturbance which persists from the start, $t=0$. The weighting matrix, $W = I$ produces the following residual responses as shown in Figure 1.

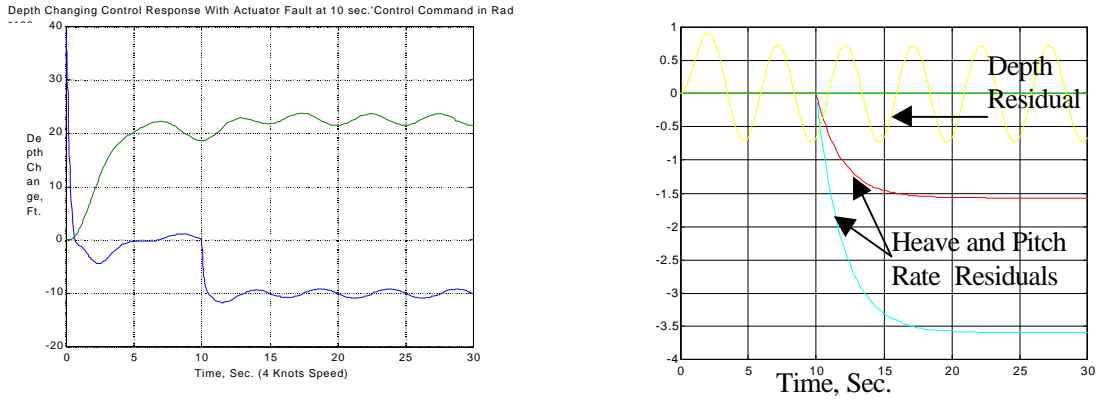

Figure 1. Fault Detection Decoupled Residuals For Each Diving State Vs Time.

Figure 1 shows that the heave velocity residual is highly responsive to the imposed actuator fault and will easily detect the fault when compared against a threshold. It appears that heave relative velocity is insensitive to wave motions which appear strongly in the depth residual response. In contrast, the wave disturbance is detected by the depth residual without influence from the actuator fault.

Detecting faults and isolating their origins is the subject of robust residual generator design and this observer with a relatively slow bandwidth illustrates that some isolation is possible. However, robustness is improved when residuals from a variety of different sources are compared. For instance, the fin activation levels, the levels of servo errors, and the observer-based residuals are all useful in the final determination of faults. The combination of all sources of information is illustrated with the fault detection architecture illustrated in Figure 2.

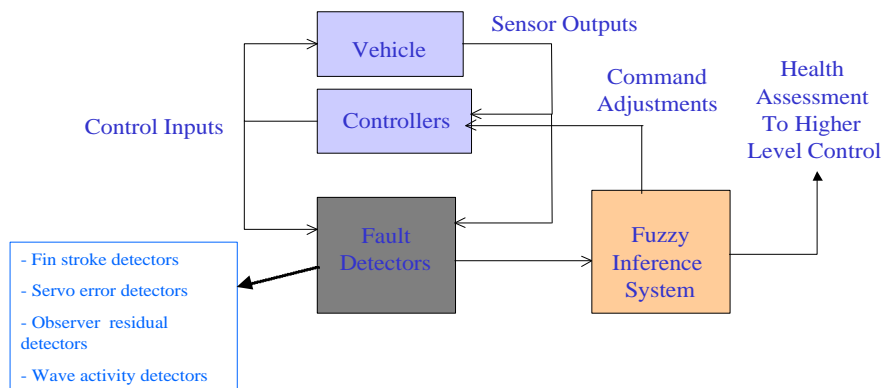

Figure 2 Fault Detection Architecture Including Fuzzy Inference System for Resolution of Fault State

CONCLUSION

The paper has demonstrated that actuator faults can be detected in the presence of wave induced disturbances. However, because of the complexity of the environmental disturbances and the variety of possible faults, a more comprehensive detection system is being proposed that includes assessment of actuator levels, servo error levels, and observer based residuals to make the overall determination of sub system health for AUVs.

ACKNOWLEDGEMENTS

The author wishes to recognize the Office of Naval Research for financial support during the conduct of this continuing study.

REFERENCES

- [1] "Intelligent Control: Fault Detection and Compensation", ONR Workshop, Naval Postgraduate School Monterey, March 1997
- [2] Gertler, J., "Failure Detection and Isolation in Complex Plants – A Survey", IFAC Symposium on Microcomputer Applications in Process Control', Istanbul, Turkey, 1986.
- [3] Healey, A. J., Course Notes Marine Vehicle Dynamics, 1995
- [4] Healey, A. J., Lienard, D., "Multivariable Sliding Mode Control for Autonomous Diving and Steering of Unmanned Underwater Vehicles", IEEE Journal of Oceanic Engineering Vol. 18, No. 3, July 1993 pp. 1-13.
- [5] Cristi, R., Healey, A.J., Papoulias, F.A., "Adaptive Sliding Mode Control of Autonomous Underwater Vehicles in the Dive Plane" IEEE Journal of Oceanic Engineering, July 1990
- [6] Patton, R. J., Chen, J., "Robust Fault Detection Using Eigenstructure Assignment: A Tutorial Consideration And Some New Results", *Proceedings of 30th. Conference on Decision and Control*, 1991, pp. 2242 – 2247.
- [7] Young, D. B., "Model Investigation of the Stability and Control Characteristics of the Contract Design for the Deep Submergence Rescue Vehicle (DSRV)", *NSRDC Report # 3030*, April, 1969.