



Calhoun: The NPS Institutional Archive

Theses and Dissertations

Thesis Collection

1995-09

Lethal unmanned air vehicle feasibility study

Green, John K.

Monterey, California. Naval Postgraduate School

<http://hdl.handle.net/10945/35138>



Calhoun is a project of the Dudley Knox Library at NPS, furthering the precepts and goals of open government and government transparency. All information contained herein has been approved for release by the NPS Public Affairs Officer.

Dudley Knox Library / Naval Postgraduate School
411 Dyer Road / 1 University Circle
Monterey, California USA 93943

<http://www.nps.edu/library>

**NAVAL POSTGRADUATE SCHOOL
MONTEREY, CALIFORNIA**



THESIS

**LETHAL UNMANNED AIR VEHICLE
FEASIBILITY STUDY**

by

John K. Green

September 1995

Thesis Advisor:

Isaac I. Kaminer

Approved for public release; distribution is unlimited.

19960319 116

DTIC QUALITY INSPECTED 1

REPORT DOCUMENTATION PAGE

Form Approved OMB No. 0704-0188

Public reporting burden for this collection of information is estimated to average 1 hour per response, including the time for reviewing instruction, searching existing data sources, gathering and maintaining the data needed, and completing and reviewing the collection of information. Send comments regarding this burden estimate or any other aspect of this collection of information, including suggestions for reducing this burden, to Washington Headquarters Services, Directorate for Information Operations and Reports, 1215 Jefferson Davis Highway, Suite 1204, Arlington, VA 22202-4302, and to the Office of Management and Budget, Paperwork Reduction Project (0704-0188) Washington DC 20503.

1. AGENCY USE ONLY (Leave blank)		2. REPORT DATE September 18, 1995	3. REPORT TYPE AND DATES COVERED Master's Thesis	
4. TITLE AND SUBTITLE LETHAL UNMANNED AIR VEHICLE FEASIBILITY STUDY			5. FUNDING NUMBERS	
6. AUTHOR(S) Green, John K.				
7. PERFORMING ORGANIZATION NAME(S) AND ADDRESS(ES) Naval Postgraduate School Monterey CA 93943-5000			8. PERFORMING ORGANIZATION REPORT NUMBER	
9. SPONSORING/MONITORING AGENCY NAME(S) AND ADDRESS(ES)			10. SPONSORING/MONITORING AGENCY REPORT NUMBER	
11. SUPPLEMENTARY NOTES The views expressed in this thesis are those of the author and do not reflect the official policy or position of the Department of Defense or the U.S. Government.				
12a. DISTRIBUTION/AVAILABILITY STATEMENT Approved for public release; distribution is unlimited.			12b. DISTRIBUTION CODE	
13. ABSTRACT (maximum 200 words) The 1991 Gulf War revealed to U.S. military planners a serious weakness in the ability of our nation's armed forces to detect and destroy mobile theater ballistic missiles systems before an enemy has the chance to use these weapons at least once, and in some cases, multiple times. Since that time there have been various studies done to show that unmanned air vehicles (UAVs) could be used to more effectively locate these mobile missile threats. However, few, if any studies, have addressed the subject of using these same UAVs to not only locate an enemy target, but to also destroy it. Therefore, this thesis provides a survey of both recent and expected future advances in UAV technology with the purpose of showing that a "Lethal" UAV is both viable and desirable as an attack platform in the U.S. weapons arsenal. To accomplish this goal the reader is given a historical review of UAVs and their important missions, an in-depth overview of the Department of Defense's most capable UAVs, and a description of the sensors and payloads most likely to be used in the design of a Lethal UAV. Lastly, some possible Lethal UAV systems are presented along with an assessment on the feasibility of fielding such systems. While the primary objective of this thesis is to show that UAVs can be used to effectively locate and destroy mobile weapon systems, this document should also be used as a reference for those persons desiring an update on UAV technology and the DoD programs for testing and utilizing this technology.				
14. SUBJECT TERMS Unmanned Air Vehicle (UAV), Lethal UAV, Ballistic Missile Defense, Tier UAV Program, UAV Sensors and Payloads, UAV History			15. NUMBER OF PAGES 92	
			16. PRICE CODE	
17. SECURITY CLASSIFICATION OF REPORT Unclassified	18. SECURITY CLASSIFICATION OF THIS PAGE Unclassified	19. SECURITY CLASSIFICATION OF ABSTRACT Unclassified	20. LIMITATION OF ABSTRACT UL	

Approved for public release; distribution is unlimited

LETHAL UNMANNED AIR VEHICLE FEASIBILITY STUDY

John K. Green
Lieutenant, United States Navy
B.S., United States Naval Academy, 1987

Submitted in partial fulfillment of the
requirements for the degree of



MASTER OF SCIENCE IN AERONAUTICAL ENGINEERING

from the

**NAVAL POSTGRADUATE SCHOOL
September 1995**

Author: _____

Approved by: _____



Isaac I. Kammer, Thesis Advisor

George W. Conner, Second Reader

Daniel J. , Chairman

Department of Aeronautical and Aerospace Engineering

ABSTRACT

The 1991 Gulf War revealed to U.S. military planners a serious weakness in the ability of our nation's armed forces to detect and destroy mobile theater ballistic missile systems before an enemy has the chance to use these weapons at least once, and in some cases, multiple times. Since that time there have been various studies done to show that unmanned air vehicles (UAVs) could be used to more effectively locate these mobile missile threats. However, few, if any studies, have addressed the subject of using these same UAVs to not only locate an enemy target, but to also destroy it. Therefore, this thesis provides a survey of both recent and expected future advances in UAV technology with the purpose of showing that a "Lethal" UAV is both viable and desirable as an attack platform in the U.S. weapons arsenal. To accomplish this goal the reader is given a historical review of UAVs and their important missions, an in-depth overview of the Department of Defense's most capable UAVs, and a description of the sensors and payloads most likely to be used in the design of a Lethal UAV. Lastly, some possible Lethal UAV systems are presented along with an assessment on the feasibility of fielding such systems. While the primary objective of this thesis is to show that UAVs can be used to effectively locate and destroy mobile weapon systems, this document should also be used as a reference for those persons desiring an update on UAV technology and the DoD programs for testing and utilizing this technology.

TABLE OF CONTENTS

I. INTRODUCTION	1
II. UNMANNED AIR VEHICLES – A HISTORICAL REVIEW	5
A. THE FIRST UNMANNED AIR VEHICLES	5
B. IMPORTANT EARLY DEVELOPMENTS	7
C. ISRAELI ADVANCES IN UAV APPLICATION / DEVELOPMENT	9
D. PIONEER – A REBIRTH FOR UAVS IN THE U.S.	10
E. SERVICE CONSOLIDATION OF UAV PROGRAMS	12
F. HUNTER – THE FIRST JOINT UAV	13
G. OTHER UAV PROGRAMS UNDER DOD CONSIDERATION	15
H. PREVIOUS ATTEMPTS AT LETHAL UAVS	23
I. CURRENT DOD MASTER PLAN FOR UAVS	27
III. THE DOD TIER PROGRAM	31
A. TIER I: GNAT-750	31
B. TIER II: PREDATOR	34
C. TIER II+	38
D. TIER III-: DARKSTAR	43
IV. UAV SENSORS AND PAYLOADS	49
A. ELECTRO-OPTIC SENSORS	49

B. INFRARED SENSORS	52
C. SYNTHETIC APERTURE RADAR	53
D. DATA LINKS	55
E. OTHER PAYLOADS	57
F. WEAPONS	59
V. LETHAL UAV FEASIBILITY AND EMPLOYMENT	63
A. LETHAL UAV FEASIBILITY IN GENERAL	63
B. MISSIONS MOST LIKELY FOR UAVS	66
C. LETHAL UAV DESIGNS THAT ARE MOST FEASIBLE	68
VI. CONCLUSION	71
LIST OF REFERENCES	73
INITIAL DISTRIBUTION LIST	77

LIST OF FIGURES

2.1 - Ryan 147SC Drone	5
2.2 - Teledyne Ryan Compass Cope UAV.....	7
2.3 - An Aquila UAV being Lifted by Crane to its Launcher	8
2.4 - Pioneer UAV Launching from the Deck of a U.S. Navy Ship	11
2.5 - Hunter UAV.....	14
2.6 - AAI Corporation's Shadow 200, a Maneuver UAV Candidate	17
2.7 - Westinghouse's HUNTAIR, a Maneuver UAV Candidate	17
2.8 - Exdrone UAV.....	18
2.9 - Pointer UAV.....	19
2.10 - A Sentinel UAV being Tested by Soldiers in the Field	21
2.11 - Eagle Eye UAV in Hover Mode	21
2.12 - RAPTOR Demonstrator UAV.....	24
2.13 - Pathfinder UAV [Ref. 15]	26
2.14 - Condor UAV.....	26
2.15 - Major DARO UAV Programs [Ref. 10]	27
2.16 - DoD UAV Total Landscape [Ref. 10]	28
2.17 - Operational Envelopes of DoD UAVs by Category [Ref. 10]	29
3.1 - Tier I UAV (GNAT-750)	32
3.2 - Tier II UAV (Predator)	34

3.3 - Tier II+ UAV	40
3.4 - Tier III- UAV (Darkstar)	45
4.1 - Skyball Turret	51
4.2 - Hughes' Tier II+ Turret	51
5.1 - Simulation Model for Lethal UAV System (Complete) [Ref. 35]	64
5.2 - Equations of Motion Model Used in Lethal UAV Simulation [Ref. 35]	65

LIST OF TABLES

2.1 - Close/Short Range UAVs Currently Under Government Funding	22
2.2 - Mission Need Statement Summary	30
3.1 - Tier Programs Comparison	48

LIST OF ACRONYMS AND ABBREVIATIONS

ACTD	advanced concept technology demonstration
ARPA	Advanced Research Projects Agency
BDA	battle damage assessment
BMDO	Ballistic Missile Defense Organization
BPI	boost phase intercept
C2	Command and Control
C ⁴ I	Command, Control, Communications and Computers Intelligence
CEP	circular error probable
DARO	Defense Airborne Reconnaissance Office
DoD	Department of Defense
EO	electro-optics
EW	Electronic Warfare
Fig.	Figure
FLIR	forward-looking infrared
FOV	field of view
GAO	General Accounting Office
GPS	Global Positioning System
HAE	high altitude endurance
IAI	Israel Aircraft Industries Ltd.
IFF	identification friend or foe
I-MAE	interim medium altitude endurance
INS	inertial navigation system
IR	infrared
JDISS	Joint Defense Intelligence Support System
JPEG	Joint Photographics Experts Group
JPO	Joint Project Office
JROC	Joint Requirements Oversight Council
JSIPS	Joint Service Imagery Processing System
JT	Joint Tactical
Kbps	kilobits per second
km	kilometers
LGB	laser guided bomb
LHA	amphibious assault ship
LOCATM	Low Cost Advanced Technology Missile
LOS	line-of-sight
LPD	amphibious assault ship
LRIP	low rate initial production
MAVUS	maritime UAV system
MAE	medium altitude endurance

MASINT	Measurements and Signatures Intelligence
Mbps	megabits per second
MET	Meteorology
MILSPEC	military specification
mm	millimeters
MNS	mission need statement
MOTS	military off-the-shelf
MTI	moving target indicator
NASA	National Air and Space Agency
NATO	North Atlantic Treaty Organization
NBC	nuclear, biological and chemical
NIIRS	National Imagery Interpretation Rating Scale
nm	nautical miles
OSD	Office of the Secretary of Defense
OTH	over-the-horizon
PID	proportional-integral-differential
RAPTOR	Responsive Aircraft Program for Theater Operations
RATO	rocket assisted take-off
Reconn	Reconnaissance
RFP	request for proposal
RMS	root mean square
RS	Reconnaissance and Surveillance
SAM	surface-to-air missile
SAR	synthetic aperture radar
SIGINT	Signals Intelligence
TA	Target Acquisition
TACAWS	The Army Combined Arms Weapon System
TALON	Theater Applications - Launch on Notice
TD	Target Designator
TS	Target Spotting
TV	television
UAV	unmanned air vehicle
UHF	ultra-high frequency
μm	micrometers
U.S.	United States
USA	United States Army
USAF	United States Air Force
USMC	United States Marine Corps
USN	United States Navy
USS	United States Ship
VHF	very high frequency
VHSIC	very-high-speed integrated circuits
VTOL	vertical takeoff and landing

I. INTRODUCTION

Despite budget cutbacks and force drawdowns in nearly every area of the U.S. military over the past five years, unmanned air vehicle (UAV) programs have soared during that same time frame. Fueled by the operational success of the Pioneer UAV during the Gulf War in 1991, the Department of Defense (DoD) has negotiated contracts for at least seven different new UAV systems and is accepting competition on an eighth system at the time of this writing. In fact, since the Pioneer first entered service in 1986, it is estimated that the DoD has spent more than \$2 billion on the development, demonstration and acquisition of UAV systems. This spending trend is not expected to end any time soon, as two of the seven new UAV systems are scheduled to enter full production by 1997, at a cost to the taxpayer of \$1.6 billion between fiscal years 1996 and 2001. While this amount of spending pales in comparison to that spent on projects like the Air Force's B-2 aircraft, the money being spent on UAVs is astounding when one considers the road blocks faced by DoD planners in implementing UAVs prior to the Gulf War.

In light of the recent DoD interest in acquiring UAVs, one might be inclined to ask why these unmanned aircraft are being chosen over traditional manned aircraft. The answer turns out to be simple. UAVs are chosen because they excel in two important areas – mission effectiveness and cost effectiveness. UAVs are mission effective in that because they are unmanned, they can be used in heavily defended combat environments where the risk to human life is considered too great for conventional aircraft. In addition, the majority of UAVs acquired by the military exhibit exceptional endurance, a trait not shared by their manned counterparts, which gives them a considerable edge in performing the reconnaissance and surveillance mission they are most often designed for.

UAVs are cost effective simply because of the considerable savings incurred by not having to design an airplane to protect a crew. In many cases, a complete UAV system, including ground control stations and associated support equipment, costs about one-tenth that of a manned aircraft system used to perform the same mission. [Ref. 1] Like the unmanned attribute of UAVs, this cost saving attribute also makes them more

acceptable for missions where the probability of attrition is high. In an era of shrinking defense dollars, cost effectiveness, more than any other attribute, is probably most responsible for the massive surge in UAV spending.

Although UAVs proved themselves to be an irreplaceable reconnaissance asset in Desert Storm, they are also being considered by the DoD for a number of other missions including surveillance, targeting, communications relay, weather reconnaissance, electronic warfare and NBC detection. However one mission that has not received a lot of attention is the use of UAVs in the destruction of enemy mobile theater ballistic missile (TBM) systems. While the DoD has given considerable attention to using UAVs in the detection of these missile systems, any serious plans for incorporating UAVs in their destruction appears to have been abandoned [Ref. 2]. This is most unfortunate in that only through immediate destruction after detection can one ensure that a TBM system is prevented from either having time to fire or from moving back into hiding. This, of course, leads one to the obvious conclusion of using a UAV for both detection and destruction, a prospect, that until recently, has been impractical for a variety of reasons. This "Lethal" UAV would serve as a platform that could be used for the real time surveillance of a hostile area, seeking out mobile targets (which are impervious to preplanned attack weapons like cruise missiles) and destroying them, either autonomously or at the direction of a remote operator.

The primary objective of this thesis is to show that, given the recent advances in UAV technology and design, a Lethal UAV is both viable and desirable as an attack platform in the United States' weapons arsenal. To accomplish this goal the reader will be given a historical review of UAVs and their important missions, an in-depth overview of the DoD's most capable UAVs, and a description of sensors and payloads most likely to be used in the design of a Lethal UAV. Lastly, some possible Lethal UAV systems will be presented along with an assessment on the feasibility of fielding such systems.

A secondary objective of this thesis is to bring the reader up to date on current UAV technology and the DoD programs for testing and utilizing this technology. To this end, it should be noted that this thesis serves as an update to thesis work done in 1993 by

another Naval Postgraduate School student in the area of UAV technology and its impact on the feasibility of a Lethal UAV [Ref. 1].

Additionally, it should be noted that this thesis is written to support design work previously done by the author and other graduate students in which computer simulation was used to provide a proof of concept for the use of a non-specific UAV in a lethal role. A brief description of this design work and the results obtained are provided in Chapter V.

II. UNMANNED AIR VEHICLES – A HISTORICAL REVIEW

A. THE FIRST UNMANNED AIR VEHICLES

To trace the origins of UAVs one must go back to the year 1960 when the U.S. Air Force ordered its first study into the feasibility and integration of using modified target drones for intelligence gathering. The study, done on a shoestring budget of \$200,000, was particularly timely in that earlier in that same year Air Force pilot Gary Powers was shot down in a U-2 reconnaissance plane and held captive by the Soviet Union for several months. When a second U-2 pilot was shot down while flying a reconnaissance mission over Cuba only two years later, it became evident to most, if not all, military planners that in the interest of human safety, UAVs should be looked at as an alternative to manned reconnaissance flights. By that time the Ryan Aeronautical Company had already successfully demonstrated that its jet-powered Ryan 147 drone (Fig. 2.1), a modification of its already successful Q-2C series target drones, could be used effectively in a reconnaissance role. Thus by the start of the Vietnam Conflict in August 1964, UAVs were ready to begin a long and successful string of over 3400 operational sorties that would prove their worth in a variety of reconnaissance missions.

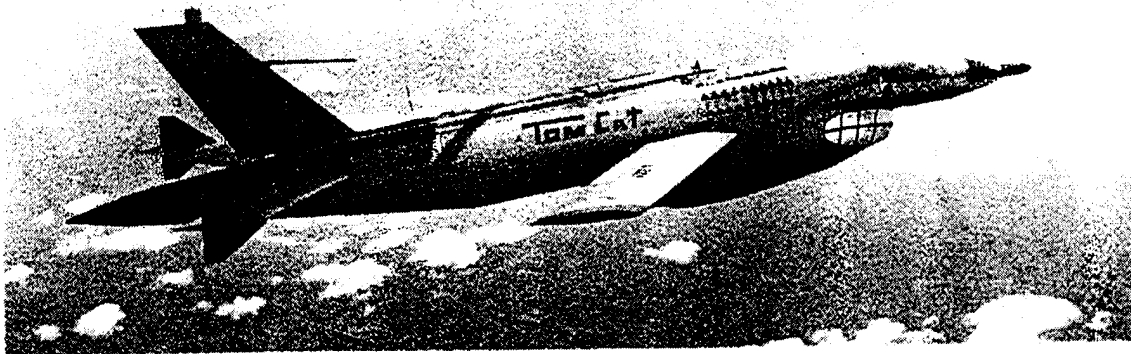

Dave Gossett, Teledyne Ryan Aeronautical

Fig. 2.1 - Ryan 147SC Drone

Therefore it could probably be said that UAVs evolved in 1962 out of the target drone industry, with the distinctive difference between the two aircraft being the requirement for UAVs to return to their operators for reuse. This is a convenient distinction in that it separates cruise missiles from the UAV category, and allows one to focus only on those vehicles that are more aircraft-like in nature, that is, those carrying a payload designed for reuse. Nonetheless, regardless of their intended mission, unmanned aircraft of the Vietnam era continued to be known as drones and the term drone is still used to this day, mainly to describe high speed, jet-powered UAVs.

As mentioned previously, UAVs did serve very successfully in the Vietnam Conflict with nearly all of the over 3400 sorties flown involved in some type of photo reconnaissance. The Ryan 147 series drones, manufactured in over 30 different variants, served as America's reconnaissance "workhorse" during the conflict, with a nearly 84 per cent survivability rate. By 1972, this figure had climbed to greater than 90 per cent, with the introduction of more sophisticated models. Most importantly, UAVs enabled the United States to gather a significant portion of its reconnaissance information at no risk to U.S. pilots. This fact is particularly impressive when one realizes that the U.S. lost over 5000 manned aircraft and about an equal number of aircrew during the period. In fact, nearly 90 per cent of all U.S. servicemen taken prisoner during the conflict were pilots or aircrewmen. [Ref. 3]

Given the operational success and vast number of lives that were most certainly spared by the use of UAVs in Vietnam, one would have expected that unmanned aircraft were set to become a new "force multiplier" in the U.S. military's arsenal. But this was not the case. In fact, within five years the U.S. had completely eliminated UAVs from its operational inventory and American research and development in the field was dwindling. This lack of interest on the part of the DoD was due, most likely, to a limited availability of funds after the Vietnam conflict.

B. IMPORTANT EARLY DEVELOPMENTS

Nonetheless, there were important advances made in UAV technology just as the Vietnam conflict was ending. These included advances in endurance, operating altitude, range and stealth technologies and are best exemplified by aircraft built by both Teledyne Ryan and Boeing as competitors in the Air Force's "Compass Cope" project, which began in 1971. The primary requirements of the project were to build a high-altitude, long-endurance UAV that would take off and land from a runway and could be used for round-the-clock reconnaissance station keeping. Although Boeing was eventually awarded the contract in 1976, by early 1974 both companies had aircraft that met or exceeded the demands of the program. Both aircraft were larger than any UAVs that had been built up to that time, with the Teledyne Ryan UAV (Fig. 2.2) weighing in at over 14,000 pounds. This same UAV had a wingspan of 81 feet, a cruising altitude of over 55,000 feet and maximum endurance of up to 30 hours. In addition the vehicle could carry a 750 pound payload and incorporated first generation stealth technologies. However, for all its capabilities, the Compass Cope program was never completed for two reasons - 1) potential payloads for the UAV were not maturing as expected, and 2) the program was deemed to be too costly given the then current operational need. [Ref. 4]

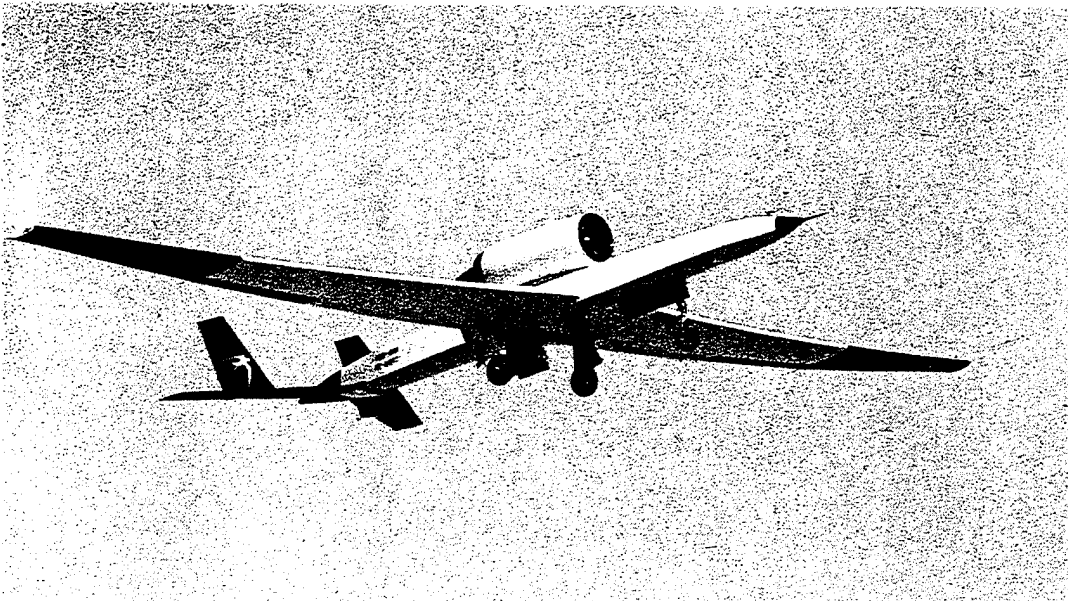

Bud Wolford, Teledyne Ryan Aeronautical

Fig 2.2 - Teledyne Ryan Compass Cope UAV

Another program that was typical of the era was the U.S. Army's contract with Lockheed for development of a small, short-range tactical UAV that could be operated from the battlefield. The result of this venture was the Aquila (Fig. 2.3), a 300 pound UAV with a flying-wing design and a shrouded pusher-prop. This aircraft had a wingspan of nearly 13 feet and was designed to be catapult launched from a five-ton truck and recovered by flying into a net rigged across the back of a second large truck. The UAV had a top speed of 130 mph, a maximum altitude of nearly 15,000 feet, and an endurance of up to 10 hours. In addition, because the aircraft was made primarily from composite materials it had a significantly reduced radar signature. [Ref. 5]

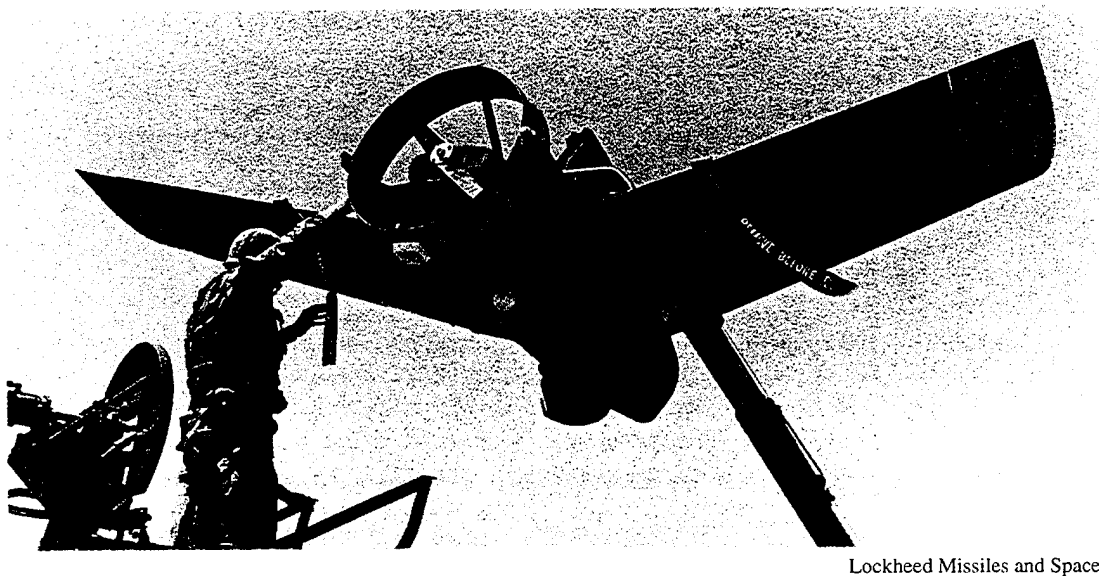

Fig 2.3 - An Aquila UAV being Lifted by Crane to its Launcher

The original missions of the Aquila were to be reconnaissance, target acquisition and laser target designation, but this list of mission requirements later grew substantially, a fact that was largely responsible for the program's ultimate downfall. In the end, it was a series of budget cuts imposed by Congress, as well as an overly ambitious list of operational requirements that led to massive delays and eventually the termination of the Aquila program in 1987, 13 years after it had begun in 1974. [Ref. 5]

Despite the obvious advances in UAV technology made during the 1970's with programs like Compass Cope and Aquila, the U.S. military was unable to use the lessons learned from the Vietnam Conflict to convince Congress that UAVs should be a permanent part of the military's warfighting arsenal. In fact, not until 1986, and then only on a limited scale, would the American military once again utilize UAVs in an operational role. Instead, it would be the nation of Israel that would take the lessons learned about UAVs in Vietnam, apply them, and once again prove that UAVs can be a powerful force multiplier when used appropriately in armed conflict.

C. ISRAELI ADVANCES IN UAV APPLICATION / DEVELOPMENT

In 1973 the Israeli's first gained an appreciation for UAVs when they successfully used them as radar decoys to deceive and saturate Egyptian SAM batteries during the Yom Kippur War. Encouraged by the resultant reduction in manned aircraft losses, Israel signed contracts with two companies, Israel Aircraft Industries (IAI) and Tadiran, for the development of small, low-signature UAVs that would be capable of transmitting real-time intelligence via direct video link. An additional requirement was that the UAVs were to be designed for use in the field by soldiers with as little as three months of training. [Ref. 3]

The result of Israel's contracts with IAI and Tadiran were the Scout and Mastiff UAVs, respectively, both of which are small (under 350 pounds) twin-boom, pusher-prop aircraft designed with versatility in mind. Not long after they were delivered both UAVs proved themselves capable in combat during Israel's 1982 "Peace for Galilee" offensive against Syrian forces in Lebanon. During the campaign UAVs equipped with reflectors were used as radar decoys to draw the fire of Syrian gun and missile batteries, allowing other UAVs carrying explosive charges to fly in undetected, home in on the Syrian radar signals and destroy them on impact. With the Syrian radars destroyed, the follow-on waves of manned aircraft were able to proceed to their targets virtually untouched by the

air defense batteries, ensuring a decisive Israeli victory, without the loss of any aircrew. [Ref. 3].

D. PIONEER – A REBIRTH FOR UAVS IN THE U.S.

With the impressive results posted by small and relatively inexpensive Israeli UAVs in 1982, U.S. Navy planners began to wonder if perhaps a similar sized UAV might not fulfill the need for accurate over-the-horizon targeting onboard its fleet of battleships. This time however, unlike in previous military UAV programs that had failed, the decision was made to utilize nondevelopmental technology, a decision that would allow the Navy to test and procure a limited quantity of UAV systems quickly and without the high costs associated with research and development. Not surprisingly, the UAV chosen after a competitive flyoff in 1985 was one developed in a joint effort by IAI and Tadiran that closely resembles both the Scout and Mastiff UAVs. This UAV, now known as the Pioneer (Fig. 2.4, next page), was delivered to the Navy less than six months after the flyoff, and within a year a system of five Pioneer UAVs was deployed onboard the battleship *USS Iowa*. Satisfied with both the operational capabilities of the UAV as well as its affordability, the decision was made to acquire three more systems for use by the U.S. Marine Corps (USMC), and these three systems were operationally deployed onboard amphibious attack (LHA) ships as well as with several land based units. In 1989, the U.S. Army, which had canceled its contract for the Aquila UAV just two years earlier, took possession of a Pioneer system and had integrated it into operational use by the following year. By the time Operation Desert Shield began in 1990, there were a total of nine Pioneer systems in use: four Navy systems, three USMC systems, one Army system and one DoD training system.

If there was ever a chance for UAVs to regain the status that they had lost since the end of the Vietnam Conflict, Operations Desert Shield and Desert Storm provided that chance. During the Gulf War the Pioneer quickly earned the trust and admiration of USA, USN, and USMC commanders as six operational units from three services flew

over 300 combat missions with the UAV. Intelligence information that would have been otherwise unattainable was gathered for use by all Coalition forces, and through it all only one Pioneer was shot down. [Ref. 6]

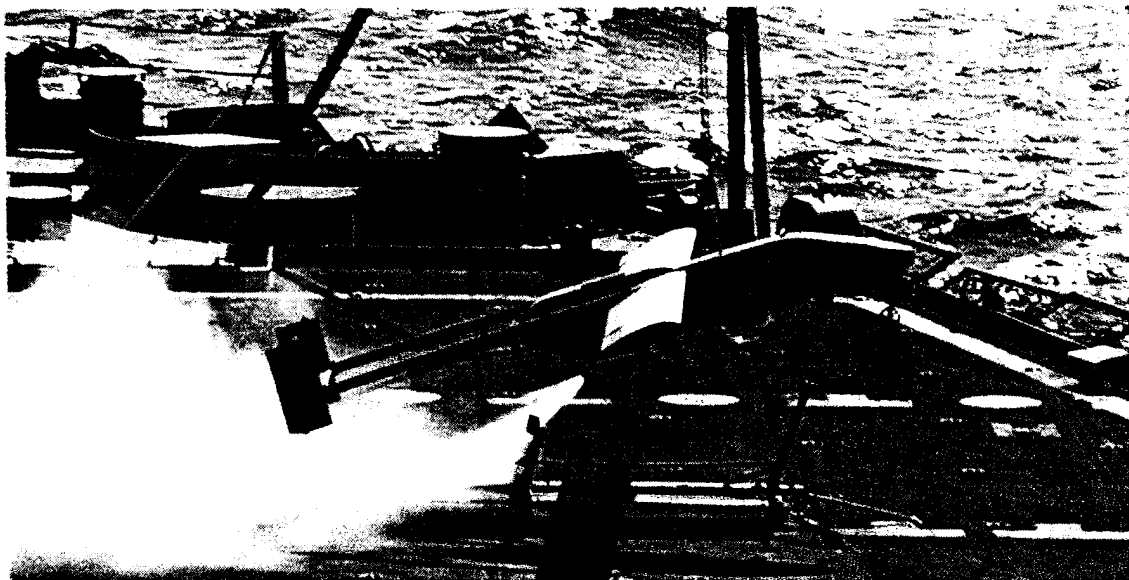

Pioneer UAV Inc.

Fig. 2.4 - Pioneer UAV Launching from the Deck of a U.S. Navy Ship

During the conflict Navy units flew the Pioneer from two different battleships, using its cameras to assist in target selection, battle damage assessment (BDA) and spotting gunfire from the battleships' 16-inch guns. Marine Corps units used the Pioneer to direct air strikes and provide near real-time reconnaissance for special operations while the Army used the UAV to conduct BDA, area searches, route reconnaissance and target location. Perhaps the most famous of the system's achievements, if not the most effective, was when a Pioneer captured camera footage of several Iraqi soldiers abandoning their fighting positions and surrendering to the unarmed UAV, an event that was undoubtedly demoralizing to Iraqi officials when it made world news coverage. [Ref. 6]

Today the Pioneer remains in the U.S. military's operational inventory, and as of 1994 had flown more than 10,000 operational flight hours. With the retirement of the Navy's battleship fleet after the Gulf War, the decision was made to outfit six amphibious assault (LPD) ships to handle the Pioneer, two of which have made deployments to Africa and the Adriatic Sea in support of U.S. and United Nations operations [Ref. 6]. To date, the Pioneer has flown more than 2300 combat flight hours on more than 800 combat sorties, all at a total cost of less than \$325 million as of 1994. This of, course, is less than the cost of most feasibility studies for new manned aircraft systems and is orders of magnitude less than the research and development that goes into a new manned aircraft.

During Desert Shield/Storm the Pioneer flew most of its missions outfitted with either a gyro stabilized high resolution TV camera or FLIR camera, for day or night operations respectively. The output of both cameras are typically broadcast via a C band data link to a ground control station where one operator interprets the video received and a second operator either flies the UAV manually or tracks the Pioneer's preprogrammed flight. The data link used has a maximum range of 100 nm, is designed to be jam resistant, and has an omnidirectional UHF backup link for redundancy. Other components of the system that can be used are a portable control station and a remote receiving station that allows commanders in the field to receive real-time video from the UAV. Other payloads that have been successfully demonstrated on the Pioneer are meteorological sensors, radiac sensors, chemical detection sensors and communications intelligence receivers. For a more complete listing of the Pioneer's physical characteristics and performance specifications the reader is directed to Table 2.1 on page 22.

E. SERVICE CONSOLIDATION OF UAV PROGRAMS

With the U.S. Navy's start of the Pioneer program in late 1985 and the U.S. Army's ongoing Aquila program during that same time frame, many members of Congress began to question the wisdom of acquiring two separate systems with about the

same range and list of mission capabilities. As a result of this inquiry, in 1987 Congress ordered a consolidation of military UAV programs to eliminate redundancy and made the decision to freeze UAV funding pending the release of a suitable UAV master plan. Consequently, in the spring of 1988 the DoD set up the Joint Project Office (JPO) for Unmanned Air Vehicles and established the Navy as the executive service to which it would report. Under this arrangement the new office received its funding directly through the Office of the Secretary of Defense but administratively reported to the Navy's Program Executive Office for Cruise Missiles and UAVs, which reports to the Assistant Secretary of the Navy for Research, Development and Acquisition.

With a UAV Joint Project Office established, a suitable UAV master plan was soon laid out, and the focus began to shift toward finding a suitable replacement for the Pioneer. This replacement, known as the Joint Tactical (JT) UAV, would still be a short range system but would be expected to offer improvements in range, payload and endurance over the Pioneer UAV system. Like the Pioneer, the JT UAV would be required to use only nondevelopmental technology and would eventually be acquired for use by the Army, Navy and Marine Corps, necessitating both a ship and shore operational capability.

F. HUNTER – THE FIRST JOINT UAV

Perhaps buoyed by its satisfaction with the Pioneer UAV, in 1989 the JPO made a decision to contract with IAI (which designed the Pioneer) and TRW Avionics for design of the JT UAV, later known as the Hunter (Fig. 2.5, next page). However, unlike the Pioneer, this new UAV, with its long list of performance requirements designed to suit the needs of three different military services, would spend a considerable amount of time in the test and development stage, while the Pioneer UAV could be used in the interim. The first flight of a Hunter UAV was made in 1990, technical evaluation was completed in 1992, and a low rate initial production (LRIP) contract was awarded in 1993. The first Hunter system of the seven in the LRIP contract was delivered in April of 1995 and the

UAV JPO currently has plans to acquire a total of 52 Hunter systems, 18 for the Navy, five for the Marine Corps, 27 for the Army and two for a DoD training facility [Ref. 7].

Each Hunter system is made up eight UAVs, two ground control stations, a mission planning station, remote video terminals, launch and recovery subsystems and a variety of modular mission payloads. With a wing span of 29 feet, and dual 68 horsepower engines, the UAV itself is substantially larger and more powerful than its predecessor, the Pioneer. Performance specifications are also more impressive. The Hunter, with its maximum take-off weight of 1600 pounds, is capable of carrying up to a 250 pound payload and has a maximum endurance of 12 hours. In addition it is designed to operate from unimproved runways and in 1991 achieved a breakthrough by making the world's first UAV relay flight, a feature that allows the Hunter to operate at nearly twice the normal data link range by using a second Hunter vehicle that relays reconnaissance video and flight commands from/to the primary mission vehicle.

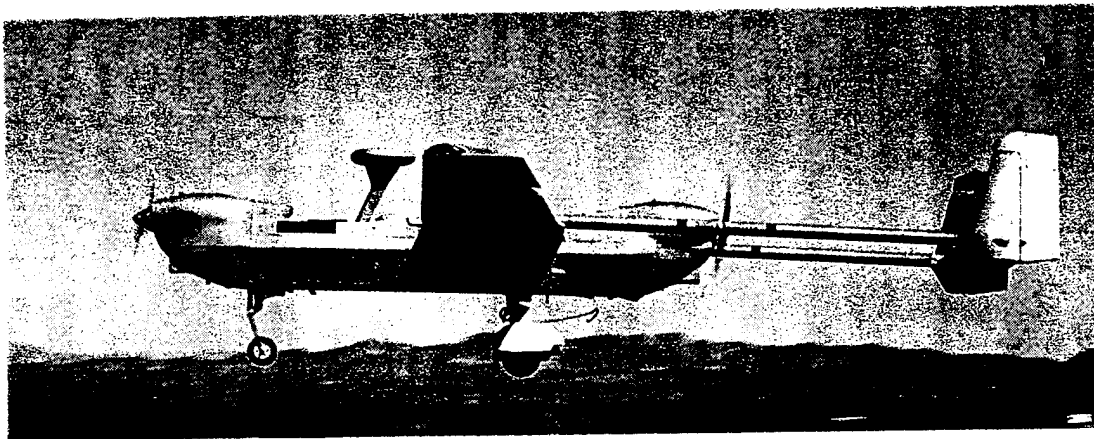

TRW / IAI

Fig. 2.5 - Hunter UAV

Payloads for the Hunter are similar to those found in the Pioneer but have been improved, a fact that is undoubtedly due to TRW's level of expertise in avionics systems. The primary payload is a dual sensor multi-mission system that provides both a gyro-stabilized TV camera and FLIR camera, with complete coverage of the aircraft's lower

hemisphere. Thus the Hunter can transition from day to night missions and vice-versa without having to land and have its sensors replaced. In addition, extra payload space and electrical power on the UAV enables the integration of larger payloads (such as a synthetic aperture radar) and allows for the carrying of multiple payloads, i.e., carrying a communications or electronic warfare suite in addition to the standard dual sensor electro-optical payload.

Additional improvements found in the Hunter system when compared to the Pioneer include a larger more graphically-oriented ground control station and the addition of an automatic landing system and heavy fuel engine, both of which are still in the developmental stage [Ref. 8]. The heavy fuel engine is particularly significant in that it will replace the current gasoline propulsion system with an engine that uses either JP5 or JP8 jet fuel, fuels that the Army and Navy have committed to using because of their availability and low volatility. Thus, the new engine will make the system both safer and logistically simpler. For a more complete listing of the Hunter's physical characteristics and performance specifications the reader is directed to Table 2.1 on page 22.

Despite many improvements boasted by the Hunter system, the JT UAV program has been beset with numerous setbacks in its development. This is primarily because the JT UAV is not being looked at as an interim solution like the Pioneer UAV was, and thus is forced to undergo a stricter set of military specifications (MILSPECS) and requirements. Consequently, the cost of the system has gone up and the program is in danger of being scaled back from 52 JT UAV systems to as few as 35 or even 20 systems [Ref. 7].

G. OTHER UAV PROGRAMS UNDER DOD CONSIDERATION

While the Hunter is the latest system to be considered for full production, there are several other UAV programs currently underway in the UAV Joint Project Office. One such program, known as the JT UAV Maneuver Variant program, is for the acquisition of a close range UAV that would be used by Army and Marine maneuver

units in the field at the brigade level. Some requirements of the program, which predate the project office itself, are that the system chosen must utilize off-the-shelf technology, have a day/night sensor package, and be small enough that a system of four vehicles can be transported on two Humvee trucks and a trailer. Other requirements are for the individual UAVs to be small enough that they can be handled and operated by a two-man team, and for a short field capability, specifically the ability to take off and land in 75 meters or less and clear a 10 meter obstacle. In addition the Maneuver UAV is to be compatible with ground control station systems already in use by the Hunter UAV. [Ref. 9]

While many leaders in both the military and Congress are skeptical of the need for this brigade level asset, the program seems to be picking up momentum and it is likely that by the fall of 1995 a formal request for proposal (RFP) will be announced [Ref. 9]. In fact, current UAV Joint Project Office plans are to choose from a list of competitor's within the next year and to begin acquisition of the Maneuver Variant by fiscal year 1997. These plans include spending nearly \$600 million on the program between fiscal years 1996 and 2001, to acquire 55 systems [Ref. 7]. Contractors who have expressed interest in bidding on the program include AAI, Northrop, McDonnell Douglas, IAI, General Atomics, Westinghouse and Alliant Techsystems [Ref. 9]. Representations of designs submitted by two of the contenders are presented on the next page in Fig.'s 2.6 and 2.7.

A small, low cost UAV that was acquired as an interim solution to the Maneuver UAV is the Exdrone (Fig. 2.8, page 18). This delta platform flying-wing UAV was originally designed by the Johns Hopkins Applied Physics Laboratory in the early 1980's and incorporates changes made by both Navy and NASA research centers. The UAV, which is made almost entirely of plastics to reduce both cost and weight, has a wingspan of 8 feet and a maximum launch weight of about 90 pounds. The Exdrone utilizes a conventional front mount propeller that is driven by a small one-cylinder, two-cycle gasoline engine and has a maximum endurance of about 2.5 hours. [Ref. 3]



AAI Corporation

Fig. 2.6 - AAI Corporation's Shadow 200, a Maneuver UAV Candidate

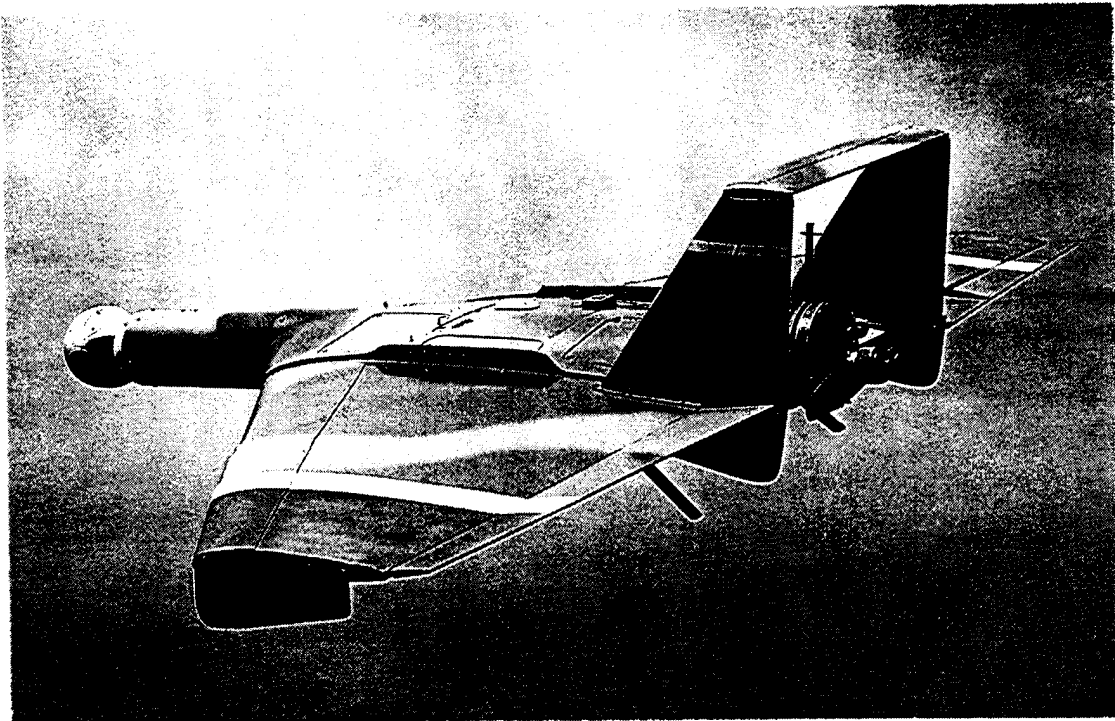

Westinghouse Electric

Fig 2.7 - Westinghouse's HUNTAIR, a Maneuver UAV Candidate

The UAV's normal payload is a fixed, down-looking zoom color camera, but image intensifiers and infra-red cameras have been tested with the aircraft as well. The Exdrone is designed to be flown in either a GPS-based autonomous mode or a remotely controlled manual override mode and a second forward looking camera is installed on the UAV to provide the remote pilot with a horizon. The data link for the system operates in the UHF band, has a maximum range of about 22 nm and is transmitted to and from a ground control station that is the size of a suitcase. Normal launch of the UAV is achieved through the use of a pneumatic rail launcher and the vehicle is recovered via parachute. [Ref. 10]

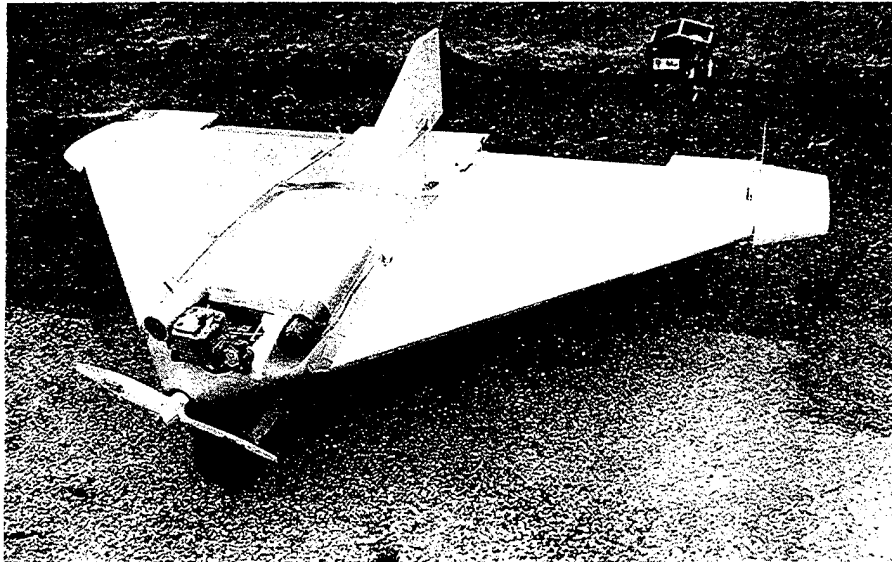

BAI Aerosystems

Fig 2.8 - Exdrone UAV

Primary goals in establishing the Exdrone demonstration program were to give the Army and Marine Corps some hands-on UAV experience, to use it as a testbed for a variety of sensors, and to provide an interim operational capability for lower echelon UAV users. To accomplish these objectives 100 Exdrone UAVs were acquired in 1992 and an additional 60 vehicles with improved capabilities were acquired in 1994 and 1995, at a cost of about \$25,000 per vehicle. [Ref. 10] For a more complete listing of the

Exdrone's physical characteristics and performance specifications the reader is directed to Table 2.1 on page 22.

Another platform that the UAV Joint Project Office has shown considerable interest in acquiring is the Pointer (Fig. 2.9), a very small, hand launched UAV designed by AeroVironment Inc. for use as an over-the-hill scouting asset. This off-the-shelf UAV system, which would be used by front-line Army and Marine Corps units, is perhaps best described as an oversized, remote-control model airplane with reconnaissance capabilities. A system of Pointer UAVs, which consists of three aircraft, a ground control unit and ground support equipment, is designed to be transportable by two soldiers wearing full mission gear and can be set up and launched in 5 minutes or less. The UAV itself has a wingspan of 9 feet, weighs just over 9 pounds and is powered by a high-tech electric motor that drives a pusher prop. The Pointer is designed to carry either a color or night vision TV camera, which is transmitted back to the ground control unit for viewing or recording at ranges of up to 4 miles. The UAV is capable of flying at up to 25 knots and has a maximum endurance of 1 hour.

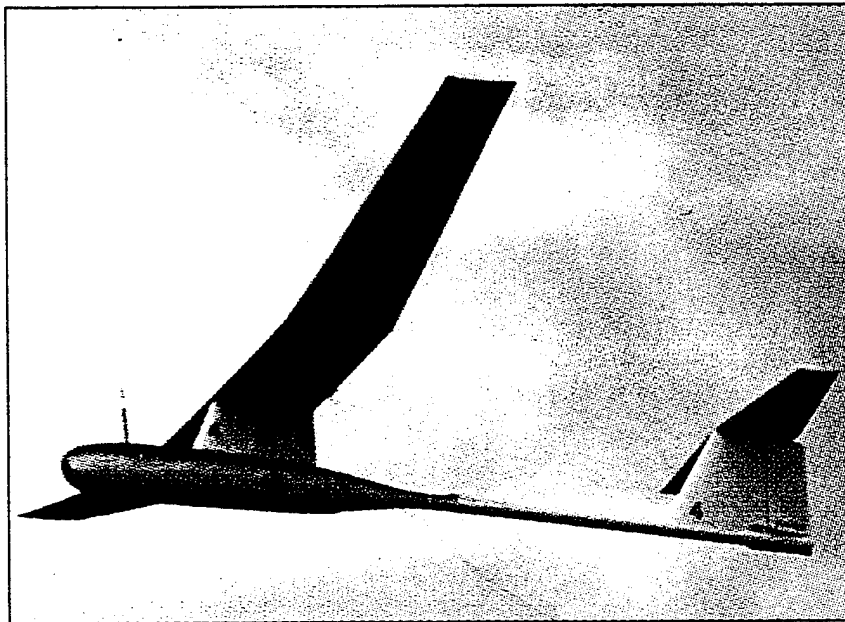

AeroVironment

Fig. 2.9 - Pointer UAV

The U.S. Army has already conducted extensive testing with ten Pointer systems that were acquired in 1990 under a demonstration program and the UAV is currently being considered for accelerated procurement with an initial requirement for 30 systems. It is estimated that once in production, each system would cost about \$100,000. [Ref. 11] For a more complete listing of the Pointer's physical characteristics and performance specifications the reader is directed to Table 2.1 on page 22.

Still another group of UAVs that the DoD has considered acquiring are vertical takeoff and landing (VTOL) UAVs, with the planned purpose of using them onboard smaller Navy ships that do not have room to operate the Hunter. In this category two different designs have evolved, both of which are being seriously considered by the Navy and by the UAV Joint Project Office. The first of these is the CL-227 Sentinel (Fig. 2.10, next page), an hourglass shaped craft with counter-rotating propellers about its middle that is designed and built by Canada's Canadair. This lightweight UAV (400 pounds maximum takeoff weight), which is also a contender in the JT UAV Maneuver program, has already undergone extensive testing onboard Navy ships under the Maritime UAV System (MAVUS) test program. It is expected, that if eventually acquired, the UAV would be used primarily for short range aerial surveillance, over-the-horizon targeting and communications relay. [Ref. 10]

The second design being considered in the VTOL category is the Eagle Eye (Fig. 2.11), a tiltrotor UAV built by Bell Helicopter that is basically an unmanned, scaled-down version of the V-22 Osprey aircraft built by the same company. Current plans are for the Pentagon to buy seven of these UAVs in fiscal year 1997 for shipboard testing [Ref. 7]. In addition to the missions listed above for the Sentinel, the Eagle Eye, because of its capability to fly faster (over 200 knots in the airplane mode), could be used on longer range missions in much the same way as the Hunter. For a listing of physical characteristics and performance specifications for both the Eagle Eye and the Sentinel the reader is directed to Table 2.1 on page 22.

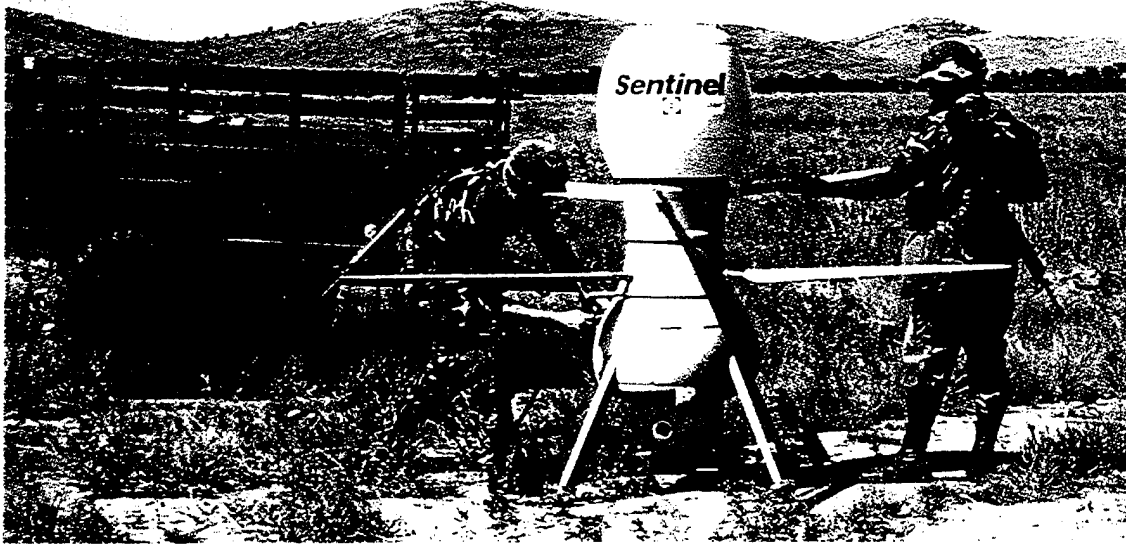

Canadair

Fig. 2.10 - A Sentinel UAV being Tested by Soldiers in the Field

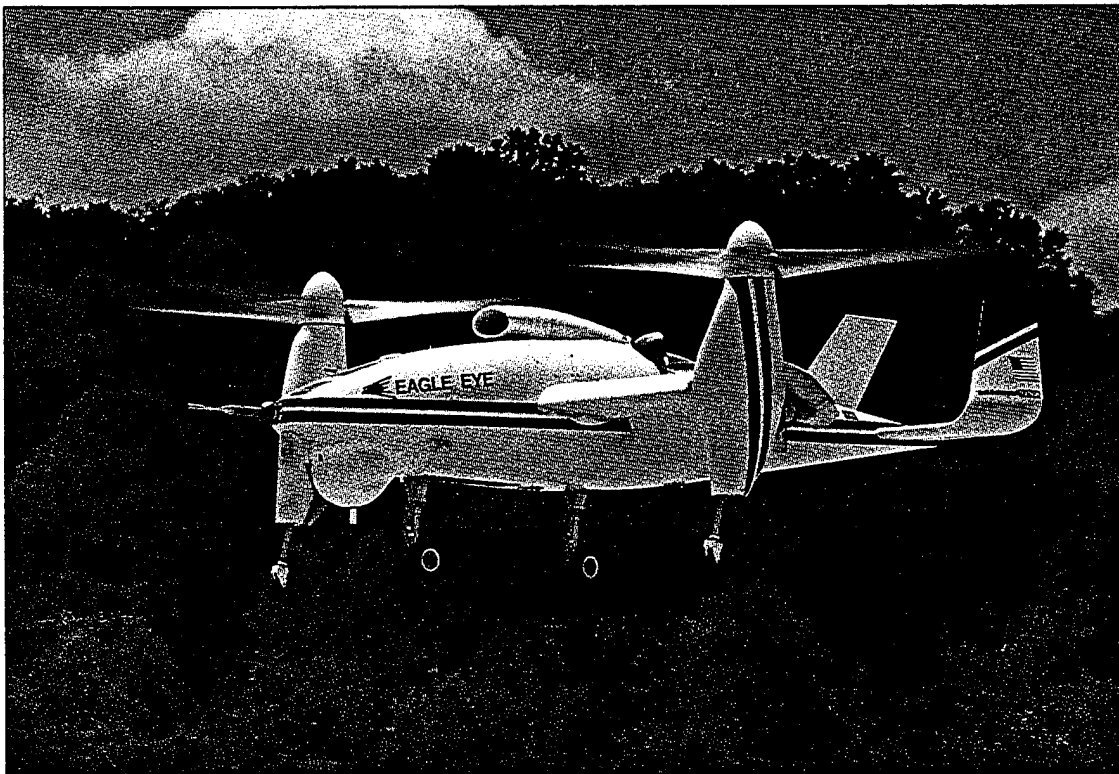

Bell Helicopter Textron

Fig. 2.11 - Eagle Eye UAV in Hover Mode

Characteristic	Fielded Systems		Demonstration Programs			
	Pioneer	Hunter	Exdrone	Pointer	Sentinel	Eagle Eye
Altitude	16,000 ft	23,000 ft	10,000 ft	1000 ft	11,000 ft	>20,000 ft
Endurance	5 hrs	11.6 hrs	2-3 hrs	1 hr	2 hrs	>2 hrs
Oper. Radius	100 nm	150 nm	21 nm	6 nm	32 nm	110 nm
Max. Speed	85 kts	>90 kts	85 kts	25 kts	70 kts	>200 kts
Propulsion	1 Recip 28 hp	2 Recip 68 hp	1 Recip 8 hp	1 Electric 300 Watt	One 60 hp Turboshaft	One 420 hp Turboshaft 2 Props
Takeoff Wt.	440 lbs	1540 lbs	90 lbs	10 lbs	420 lbs	1800 lbs
Payload Wt.	100 lbs	200 lbs	25 lbs	1 lb	100 lbs	200 lbs
Span / Length	17/14 ft	29/23 ft	8/4 ft	9/6 ft	9 ft/NA	21/16 ft
Sensor Type	TV, FLIR	EO, IR	TV	TV	EO, IR	TBD
Data Link	C-Band	C-Band	485 Mhz Uplink 1.8 Ghz Downlink	485 Mhz Uplink 1.8 Ghz Downlink	C-Band	C-Band
Data Rate	20 Mhz	20 Mhz	20 Mhz	20 Mhz	20 Mhz	20 Mhz
Deployment	4-5 per C-5 Shipboard	Multiple C-130	Single C-130	2-person carry	Shipboard	Shipboard
Launch & Recovery	Runway, RATO/Net	Unimproved Runway, RATO/Wire	Rail / Parachute	Hand Launch / Deep Stall	VTOL	VTOL
Operation	Preprogrammed or Remote Control	Preprogrammed or Remote Control	Preprogrammed or Remote Control	Remote Control	Remote Control	Preprogrammed or Remote Control

Table 2.1 - Close/Short Range UAVs Currently Under DoD Funding

H. PREVIOUS ATTEMPTS AT LETHAL UAVS

The limited payload of the UAVs that have been looked at for acquisition by the UAV Joint Project Office might lead one to the incorrect notion that the U.S. military has had no interest in Lethal UAVs. While it is true the original mandate in forming the joint office was that it would pursue the acquisition of only nonlethal UAVs, some of the UAVs that it has recently provided research and development money for are larger, more capable designs that could be used in a lethal role with only minor modifications, and in some cases, additional gains in technology. These UAVs, which at the time of this writing were receiving a lot of attention world-wide for their advances in capabilities, fall under the DoD's "Tier" Program. This technology demonstration program, which is now funded by the Defense Airborne Reconnaissance Office (an office of the Secretary of Defense established in early 1994 to oversee the development and acquisition of all airborne reconnaissance assets), is one that has been done in coordination with the DoD Advanced Research Projects Agency (ARPA), a long time supporter of advanced UAV technologies and concepts. As such, these Tier program UAVs are far more technically advanced than the nondevelopmental UAVs that have been described above and will therefore be discussed separately in the next chapter.

Another organization that has done considerable research into the design and use of UAVs, and that has adopted the concept of Lethal UAVs, is the Ballistic Missile Defense Office (BMDO). This office, which is not subject to the same budgetary constraints as the UAV Joint Project Office, has for years been involved in the design of very high altitude, long endurance UAVs that could be used to loiter for days, or even weeks over hostile territory in search of enemy ballistic missiles. One such UAV program that the BMDO was working on until recently and that incorporated the concept of a Lethal UAV was RAPTOR (Responsive Aircraft Program for Theater Operations). Under the RAPTOR concept, a high altitude, long endurance UAV would carry sensors to autonomously detect and track launches of theater ballistic missiles (TBMs) and then fire TALON (Theater Applications - Launch on Notice) hypersonic air-to-air missiles to

destroy them in a boost phase intercept (BPI). The need for such a system was identified during the 1991 Gulf War as a result of the Iraqi Scud missile threat. While the Patriot missile system was effective in destroying some of the Scud missiles fired, the effect of such a reentry phase intercept could have been disastrous had any of the Scuds been carrying submunitions or nuclear, biological or chemical payloads.

The demonstrator UAV (Fig. 2.12) for the program, built by Scaled Composites Inc., has a composite airframe with a 66 foot wing span and a huge 14 foot diameter propeller driven by a turbocharged gasoline engine. The UAV has a 150 pound payload and a maximum takeoff weight of 1800 pounds, nearly half of which is fuel, enabling it to cruise airborne for about 50 hours at altitudes above 65,000 feet. A typical scenario for the RAPTOR system would involve using a number of the UAVs to maintain round-the-clock station keeping over enemy territory, detecting a launch using onboard, lightweight infra-red cameras, and then firing a TALON missile upward to intercept the course of a TBM in its boost phase. [Ref. 12]

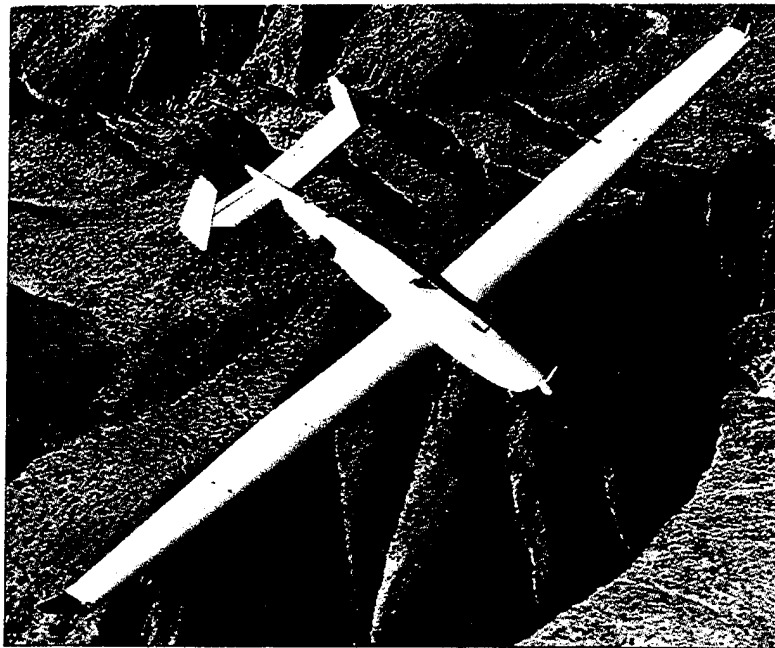

Scaled Composites

Fig 2.12 - RAPTOR Demonstrator UAV

The TALON missiles carried by the UAV would weigh only about 45 pounds and utilize emerging propulsion technologies that when combined with the relatively thin atmosphere above 65,000 feet would allow fly-out to ranges of more than 100 km at speeds in excess of 2 km per second (4,475 mph). Sensors onboard the missile would utilize advanced infra-red angle sensors and a laser rangefinder to allow the missile to home in on its target. The RAPTOR would be capable of carrying two TALON missiles (plus mission sensors) at its present size and up to four missiles if the UAV's wingspan were extended to 90 feet. [Ref. 12]

Original plans called for the BMDO to stage an advanced technology demonstration of this system in 1996, wherein an actual boost phase intercept would be conducted from the RAPTOR demonstrator [Ref. 12]. Unfortunately much of the project is based on emerging technologies, which apparently have not matured as expected, because the decision was made in late 1994 to cancel the program for other than budgetary reasons. Nonetheless the concept remains an important one that may become feasible at a later date and in the interim the RAPTOR demonstrator is being used as a testing platform for many of the sensors in development for the Tier program. [Ref. 13]

In addition to the RAPTOR demonstrator UAV, the BMDO has funded the development of other high altitude, long endurance UAVs. These include the Pathfinder (Fig. 2.13, next page), a solar powered UAV with an endurance of over 30 days and the Skysat, a microwave powered UAV that is still in development, but that if perfected, would be capable of the same level of endurance. Because of their exceptional endurance both of these were also being considered as suitable platforms for the RAPTOR program. [Ref. 13]

Another UAV currently undergoing BMDO testing is Boeing's Condor (Fig. 2.14), a composite design airframe with a 200 foot wingspan. This world's largest UAV, powered by two 175 horsepower, turbocharged reciprocating engines, holds the world's altitude record (67,000 feet) for piston-powered engines and is estimated to have an endurance of 120 hours [Ref. 5,10]. It is believed that both the Pathfinder and the Condor have been chosen as possible platforms for carrying a new high-powered laser being

developed at Lawrence Livermore National Laboratory under the program name “Defender Light” [Ref. 14].

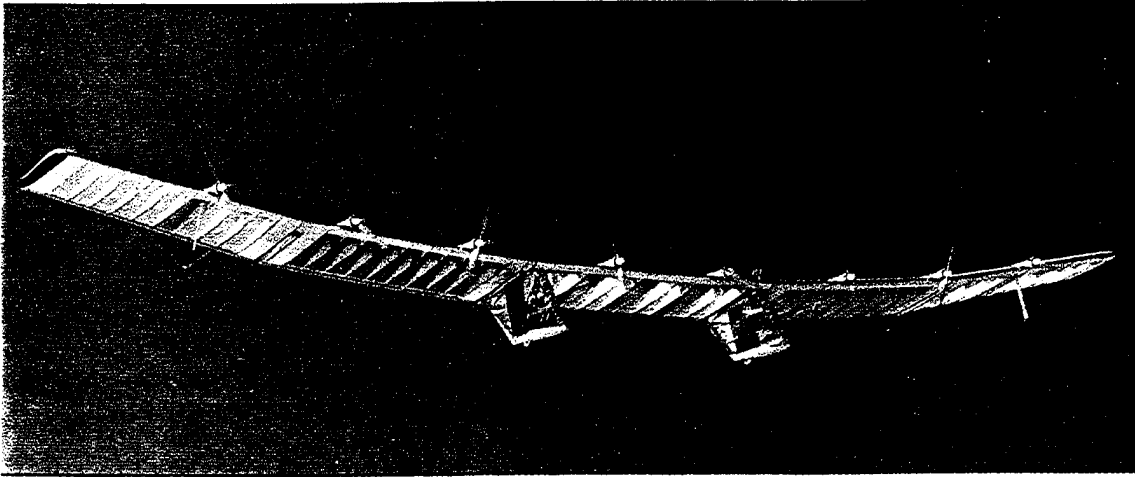
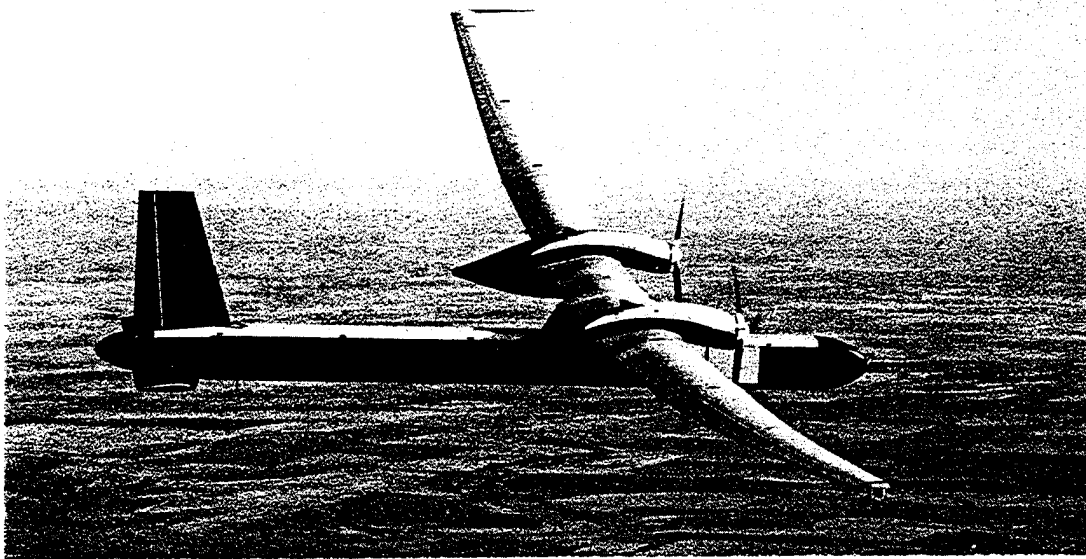

Fig. 2.13 - Pathfinder UAV [Ref. 15]



Boeing

Fig. 2.14 - Condor UAV

I. CURRENT DOD MASTER PLAN FOR UAVS

With the proven success of the Pioneer UAV in the Gulf War and establishment of the Defense Airborne Reconnaissance Office (DARO) in 1994, the future for UAVs in the U.S. military looks better than ever. In fact, if one looks at the current UAV Program Plan [Ref. 10] put out by DARO it is clear that military planners are moving along swiftly with their goals of both acquiring operational UAV systems and of demonstrating new technology and concepts. Figure 2.15 shown below is taken from the UAV Program Plan and identifies the major UAV programs that are the primary focus of the DARO. In addition, Fig. 2.16, also from the Program Plan, provides the reader with a look at where these major programs fit into the total landscape of UAVs being considered by the DoD.

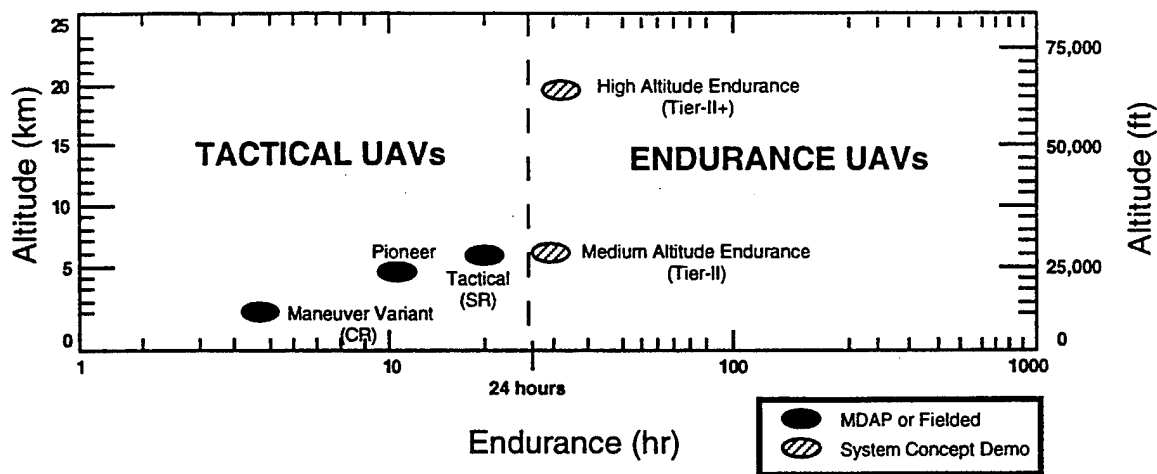

Note: Though not listed on this figure, the Tier III- program (discussed in the following chapter) is considered a major DARO UAV program and was not included in the figure because it was still a secret program when the Program Plan came out in April 1994.

Fig. 2.15 - Major DARO UAV Programs [Ref. 10]

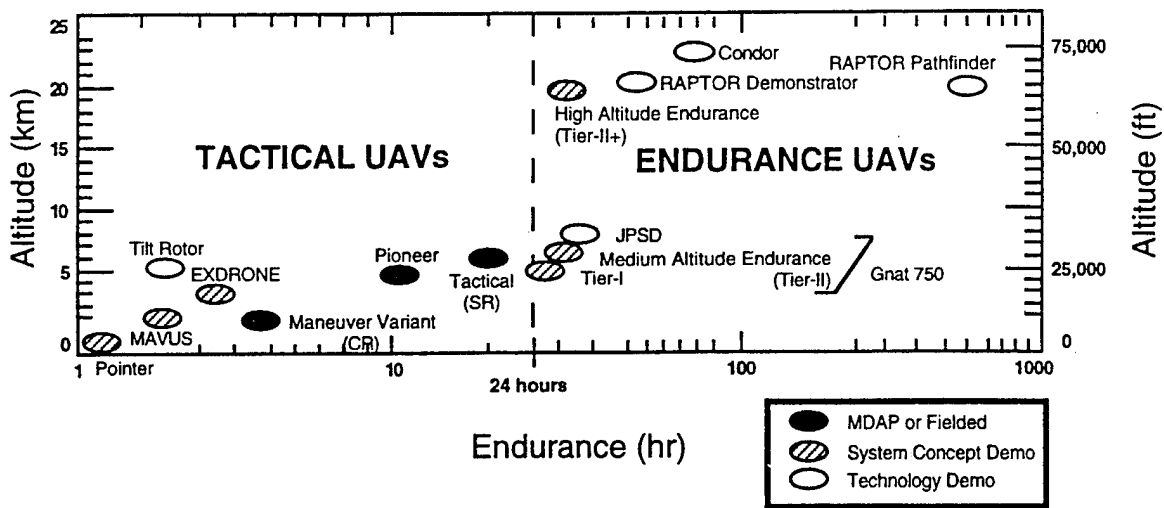

Note: Though not listed on this figure, the Tier III- program (discussed in the following chapter) is considered a major DARO UAV program and was not included in the figure because it was still a secret program when the Program Plan came out in April 1994.

Fig. 2.16 - DoD UAV Total Landscape [Ref. 10]

Another important element of the DARO's Program Plan which is reproduced in Table 2.2 on page 30, is a summary of the capabilities required to fulfill the mission need statements (MNS) for UAVs. These need statements, which are identified by the Joint Requirements Oversight Council (JROC), group UAVs into four operational categories: close range, short range, medium range and endurance. Of these four categories it should be noted that the Medium Range UAV Program, established to address the requirements of the medium range need statement, was terminated in October 1993 for reasons of affordability and the conclusion that an endurance UAV offered superior performance at lower cost [Ref. 10]. Also included below (Fig. 2.17) is a graphical depiction of the operational envelopes for each of the major UAV programs in terms of UAV radius of action versus time of flight. Lastly, it should be noted that the DARO UAV Program Plan serves as an excellent reference for those readers desiring a more detailed description of specific UAV programs and the various government agencies established to support those programs.

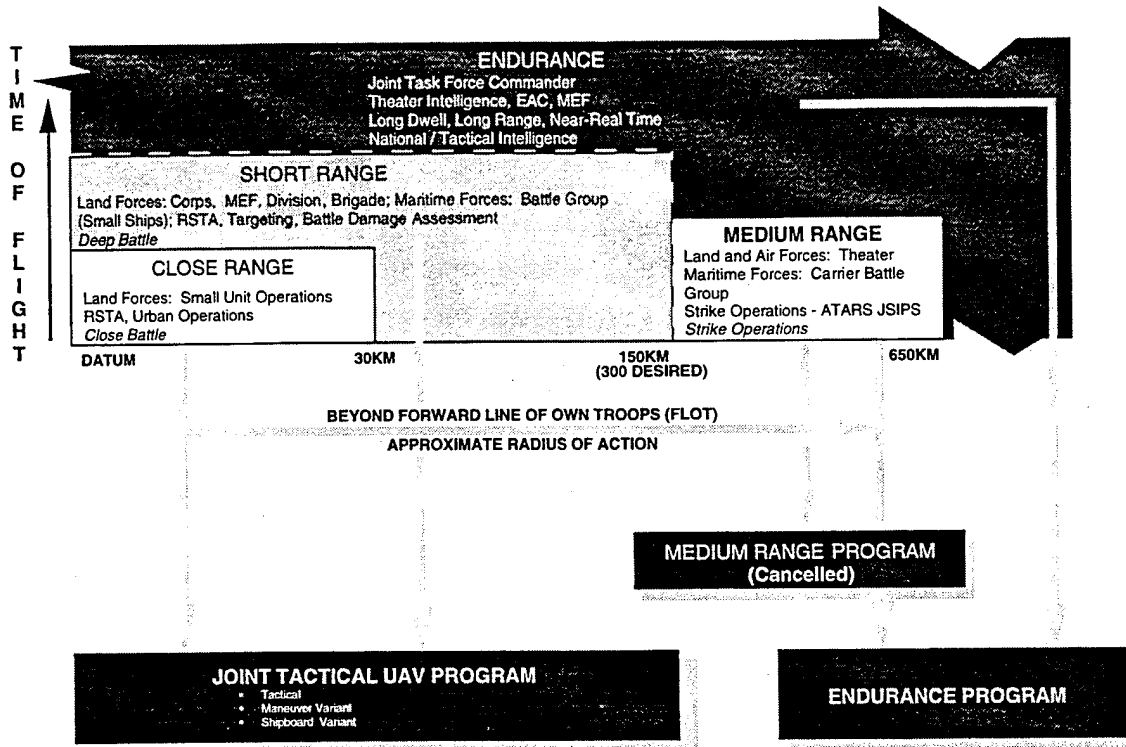

Fig. 2.17 - Operational Envelopes of DoD UAVs by Category [Ref. 10]

	JOINT TACTICAL PROGRAM*			ENDURANCE PROGRAM*
CAPABILITIES	CLOSE	SHORT	MEDIUM	ENDURANCE
Operation Needs	RS, TA, TS, EW, MET, NBC	RS, TA, TS, EW MET, NBC, C2,	Pre and Post Strike Recon, TA	RS, TA, C2, EW, NBC, SIGINT, EW, Special Ops
Launch/Recovery	Land or Ship	Land or Ship	Air/Land	Not Specified
Radius of Action	None stated	150 km beyond FLOT (forward line of own troops)	650 km	TBD
Speed	Not Specified	Dash >110 kts Cruise <90 kts	550 kts <6.5 km .9 Mach >6.5 km	Not Specified
Endurance	24 hrs Continuous Coverage	8 to 12 hrs	2 hrs	≥24 hrs on Station
Information Timeliness	Near-Real-Time	Near-Real-Time	Near-Real-Time / Recorded	Near-Real-Time
Sensor Type	EW, Day/Night Imaging, NBC	Radar, Day/Night Imaging, SIGINT, Data Relay, Comm Relay, MASINT, MET, TD, EW	SIGINT, MET, Day/Night Imaging*, EW	SIGINT, MET, COMM Relay, Data Relay, EW, NBC, Imaging, MASINT
Air Vehicle Control	None Stated	Pre-programmed/ Remote	Pre-programmed	Pre-programmed/ Remote
Ground Station	Vehicle & Ship	Vehicle & Ship	JSIPS (Processing)	Vehicle & Ship
Data Link	Worldwide Peacetime Usage, Anti-jam Capability	Worldwide Peacetime Usage, Anti-jam Capability	JSIPS Interoperable Worldwide Peacetime Usage, Anti-jam Capability	Worldwide Peacetime Usage, Anti-jam Capability
Crew Size	Minimum	Minimum	Minimum	Minimum
Service Need/ Requirement	USA, USN, USMC	USA, USN, USMC	USA, USAF, USMC	USA, USN, USMC, USAF

*Note: The broad classifications of UAVs have recently been changed to "Tactical" and "Endurance". The MNS refers to "close" and "short", which are now designated "Tactical".

LEGEND

- | | |
|---|--------------------------------------|
| C2 - Command and Control | Reconn - Reconnaissance |
| EW - Electronic Warfare | RS - Reconnaissance and Surveillance |
| JSIPS - Joint Service Imagery Processing System | SIGINT - Signals Intelligence |
| MASINT - Measurements and Signatures Intelligence | TA - Target Acquisition |
| MET - Meteorology | TD - Target Designator |
| NBC - Nuclear, Biological and Chemical | TS - Target Spotting |

Table 2.2 - Mission Need Statement Summary [Ref. 10]

III. THE DOD TIER PROGRAM

As mentioned in the previous chapter, the DoD's Tier Program is a technology demonstration program of highly advanced endurance UAVs that is being conducted by the DARO in coordination with the DoD Advanced Research Projects Agency. The program, which began in 1993, is designed to field a small number of test vehicles to evaluate their utility, concept of operations, cost and performance [Ref. 11]. The program is currently composed of four tiers with the first two tiers, Tier I and Tier II, representing Medium Altitude Endurance (MAE) UAVs, and the second two tiers, Tier II+ and Tier III-, representing High Altitude Endurance (HAE) UAVs. While both the MAE and HAE UAVs represent advances in technology, the HAE UAVs, which are still in development, are by far the most advanced and probably represent the U.S. military's best opportunity for future fielding of a fully capable Lethal UAV system. Nonetheless, because all four UAVs are capable of operating at longer ranges and endurances with acceptable size payloads, each of the four systems will be examined in detail with emphasis placed on those features that lend themselves well to use in a lethal role.

A. TIER I : GNAT-750

The Tier I program, or Interim MAE (I-MAE) program was initiated in 1993 by military planners who, after identifying the overall reconnaissance plan utilized during Desert Storm, realized that the United States was seriously in need of a platform for conducting tactical reconnaissance deep within defended enemy territory. This realization, along with the fact that the U.S. military had been steadily retiring manned reconnaissance aircraft and canceling their expensive replacements, brought military planners to a logical conclusion: that unmanned aircraft could do the same job as manned aircraft like the RF-4C and SR-71 but at a cheaper cost, and without risk to human life. [Ref. 16] Furthermore it was determined that a long endurance UAV would be required

because of the long ranges involved and therefore shorter range UAVs like the Pioneer and Hunter would be unsuitable. Therefore, when at about the same time frame, the Joint Chiefs of Staff issued a requirement for better reconnaissance in Bosnia, the decision was made to proceed quickly with already existing technology and the UAV that was selected was the GNAT-750 (Fig. 3.1). This composite built UAV which first flew in 1989 is manufactured by General Atomics Aeronautical Systems and was a somewhat natural choice in that it was developed as an outgrowth of a \$40 million Amber UAV technology program funded by the ARPA. [Ref. 17]

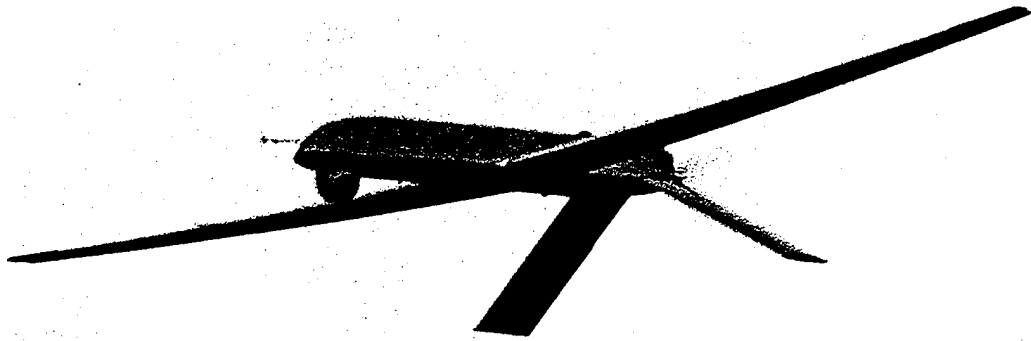

General Atomics

Fig 3.1 - Tier I UAV (GNAT-750)

The GNAT-750, with its wing span of 35 feet and gross takeoff weight of 1130 pounds, carries a normal payload of 140 pounds, but is capable of carrying up to 450 pounds of total payload. Because the UAV is made of lightweight composites, its empty weight is only 560 pounds, allowing the GNAT to carry up to 76 per cent of its own weight in fuel. It is this fact, along with the UAV's efficient reciprocating engine and pusher-prop design that enables it to fly an operational radius of 500 nm with an on-station time in excess of 24 hours. Another benefit of the UAV's composite design (and shape) is that the GNAT has a low radar signature, a feature that along with its 25,000

foot operating altitude makes the UAV very difficult to detect, both visually and on radar. [Ref. 10]

The GNAT-750 is capable of either autonomous or remote controlled flight and utilizes an integrated GPS/INS to fly a navigational track. The payload for the UAV is a multi-mission sensor package known as Skyball that contains both an electro-optical and FLIR camera in a turret mounted under the chin of the aircraft. The data link for the UAV system is in the "C" band, is frequency selectable and is capable of transmitting digital video. The system's ground control station has a 2-man flight control unit similar to that used by the Pioneer except that it utilizes better graphical interface and is engineered to be cockpit-like. In addition the ground control station has three user consoles designed for imagery analysis and mission planning. [Ref. 10]

Because the GNAT-750 was chosen as an interim solution to the need for a MAE UAV only two of them were acquired and both were used extensively by the Central Intelligence Agency to monitor ongoing events in war-torn Bosnia during much of 1994 and 1995.

From a Lethal UAV standpoint the GNAT could be used as both a reconnaissance and weapons carrying platform, although given the weight of most conventional glide bombs and missiles, the GNAT-750 would most likely only be capable of carrying one weapon and would then have a significant reduction in its endurance with the resultant loss of available fuel. Another important limitation is that video transmissions from the GNAT are limited to line-of-sight operations, giving the UAV a user-monitored range of only about 100 nm. Still another limitation in using the GNAT-750 is that its sensors are susceptible to poor weather conditions, a fact that made the platform ineffective for much of the time that it was used over Bosnia. On the other hand, at about \$800,000 per UAV, the GNAT-750 is by far the cheapest of the Tier UAVs and could be used on missions where the probability of attrition is relatively high.

For a complete listing of the GNAT-750's physical characteristics and performance specifications the reader is directed to Table 3.1 on page 48.

B. TIER II : PREDATOR

Like the Tier I that preceded it, the Tier II program was designed to provide the DoD with a quick solution to the need for near-real-time imagery of heavily defended enemy territory. In addition, the program was designed to provide a UAV with EO/IR sensors to support limited operations within 12 months, and an additional synthetic aperture radar (SAR) capability within 30 months of contract award (January 1994). [Ref. 10] The SAR capability is significant in that it will provide area commanders with the ability to obtain imagery regardless of weather and with an added Ku band satellite relay capability the UAV will be able to transmit full motion video at ranges beyond line-of-sight.

The prime contractor chosen in January 1994 to provide the air vehicle for the Tier II program was General Atomics, the same contractor that was awarded the Tier I vehicle contract. In fact, the Tier II UAV, known as the Predator (Fig. 3.2), is actually an enlarged version of the GNAT-750, with a bullet shape nose to allow room for both the SAR and a 30-inch satellite communications antenna.

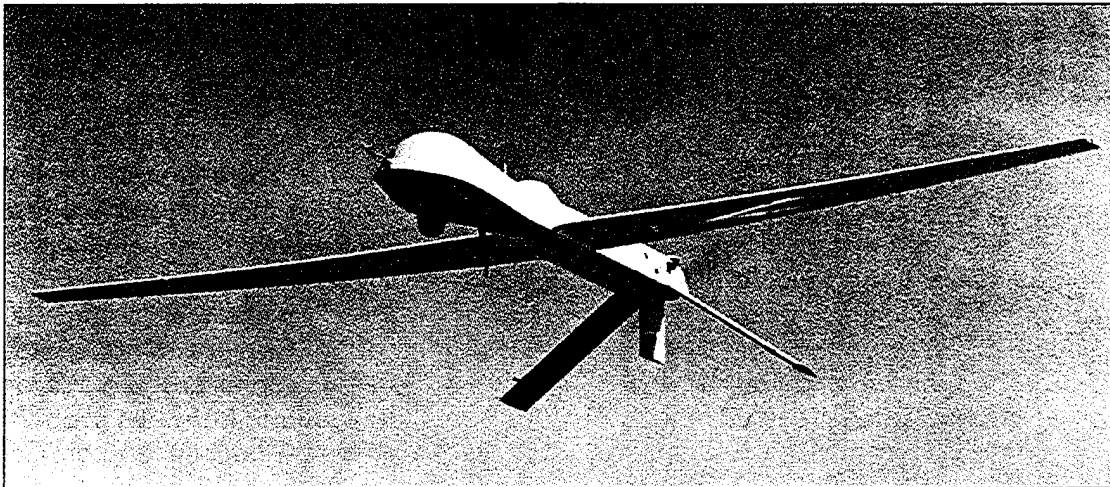

General Atomics

Fig. 3.2 - Tier II UAV (Predator)

The Predator, with its wing span of 49 feet and gross takeoff weight of 1870 pounds, is capable of carrying both a bigger payload and more fuel than the GNAT-750. In fact, while a typical mission profile is to fly a 500 nm radius and stay on station for 24 hours with a 500 pound payload, the Predator is capable of flying short missions with up to a 1000 pound payload or of flying 60 hours or more with a minimum sized payload. [Ref. 18]

Like the GNAT-750, the Predator's design makes it difficult to detect with radar and virtually invisible to optical, acoustic and infrared sensors. Composite materials and skin shaping give the Predator a radar cross section of only about 1 square meter and the UAV's efficient 85 horsepower engine is muffled for quietness and exhausted over the tail into the propeller to hide the vehicle's heat signature from below. In addition, the Predator's thin lines and gray paint scheme make it virtually invisible to the unaided eye when above 3000 feet. The UAV's low speed (70-130 knots) also makes it difficult to pick up on many types of radars. [Ref. 18]

The Predator utilizes essentially the same navigation and control as the GNAT-750, but unlike the GNAT, is being outfitted with both a UHF and Ku band satellite relay system to allow beyond line-of-sight control of both the vehicle and its sensors, thus allowing for maximum use of the UAV's impressive range and endurance. In addition the Ku band satellite link, with its data transmission rate of 1.5 Mbps, will allow the transmission of full motion video from either the SAR, electro-optics or FLIR. In addition to utilizing the same trailer mounted ground control station as the GNAT-750, the Predator is also being designed for use with a truck mounted TROJAN SPIRIT II ground station, that will offer a unique capability to retransmit imagery from the UAV system via satellite to users almost anywhere in the world. This system, which utilizes the Joint Defense Intelligence Support System (JDISS), will make the UAV's imagery available worldwide through a number of already existing C⁴I systems, and will also allow Predator operators to receive real time tasking from remotely located intelligence command authorities. [Ref. 10,19]

While currently operational Predators are flying with only the Skyball multi-mission sensor package and a UHF band satellite data link, the synthetic aperture radar and Ku band satellite data link are being flight tested on newer versions of the Predator. In addition, current plans call for retrofitting existing models to give all ten Predators that have been ordered both the Skyball package and the SAR. The SAR, which is built by Westinghouse and is a 170 pound derivative of the radar designed for the now canceled A-12 aircraft, is particularly impressive in that it will provide image resolution down to 1 foot when used at a slant range of 6 nm. [Ref. 20] For a more in-depth look at the capabilities of the SAR, as well as capabilities of the other sensors carried by the Predator, the reader is directed to Chapter IV, UAV Sensors and Payloads.

Other payloads that have been considered for use on the Predator include a laser designator, an automatic target recognition system, search and rescue sensors, an upgraded IFF system, communications relay equipment and signals intelligence receivers. An additional payload that has already flown successfully on the Predator is a 10 pound L-band transmitter that allows the UAV to send imagery directly to soldiers in the field within 70 nm of the aircraft. [Ref. 20]

Because much of the Predator's design utilizes off-the-shelf technology, the advanced concept technology demonstration (ACTD), which is not subject to the normal lengthy acquisition process, was put on a very aggressive 30 month development and delivery schedule. Within six months of initial contract General Atomics was required to deliver three Predators fitted with the EO/IR sensor package, a ground control station and a UHF satellite communications capability. Six months later (January 1995) they were required to deliver four more Predators, another ground control station and the capability of flying in stateside tactical exercises such as the Air Force's Red Flag and on overseas deployments providing a real time reconnaissance capability. [Ref. 17]

In May of 1995 the Predator did, in fact, fly in Roving Sands '95, its first tactical exercise, and performed exceptionally well. During the exercise the UAV flew over 170 hours on 18 missions and was able to detect 95% of the fixed targets in the exercise. In

addition it was able to detect about 50% of the exercise's simulated mobile Scud missiles, all of which were operated by a special Camouflage, Concealment and Deception unit. Soon after completing the Roving Sands exercise, Predator UAVs were flying in a classified Joint Special Operations Command training exercise and in early July three Predators began flying surveillance and reconnaissance missions over Bosnia in support of U.S. and NATO forces in the area. [Ref. 21] In addition, in July 1995 the U.S. Air Force established a new operational unit for flying the Predator. The new unit, designated the 11th Reconnaissance Squadron, is under the operational control of the Air Force's Air Combat Command and will operate from an auxiliary airfield near Nellis Air Force Base in Nevada.

By August of 1995 Predator UAVs flying in Bosnia will be outfitted with the Ku band satellite data link, and onboard testing of the synthetic aperture radar had begun at the time of this writing. In addition, new Predators continue to be built and by December 1995 a total of ten Tier II UAVs with both the SAR and the Skyball EO/IR package will be flying as part of the ACTD. By July 1996 the Tier II technology demonstration will be complete and military planners will decide whether to take the Predator into full production or wait for the more capable (and expensive) Tier II+ and Tier III- UAVs. [Ref. 17]

From a Lethal UAV standpoint the Predator is a suitable platform for the detection and destruction of both fixed and mobile platforms. With its ability to operate over-the-horizon and impressive endurance, the Predator would be capable of loitering over enemy territory for 20-25 hours and detecting a Scud missile or other target. It would then launch a lightweight missile and could even provide laser guidance if desired. All of this would be done under the guidance of a weapons and surveillance operator sitting hundreds of miles away in the comfort of an air conditioned ground control station. With the Predator's SAR the system would be effective in nearly any weather condition and with some advances in computer imagery processing the system could be configured to include automatic target recognition. This feature would still leave the final target

identification to a human imagery analyst but would greatly reduce operator workload by providing cueing when the system's computers calculate a target correlation. Another benefit of using the Predator as a Lethal UAV platform is that, at about \$3 million per vehicle, the Predator is still considered an attritable asset, particularly when compared to manned aircraft, all of which cost tens of millions.

Perhaps the only major limitation in using the Predator for such a mission is the UAV's limited payload available for carrying weapons. Because of the fuel required for longer reconnaissance type Scud hunting missions and the additional payload requirements of the SAR, the UAV is left with very little weight for carrying missiles and would most likely be limited to carrying one or two lightweight (under 100 pounds) missiles. Missiles this size would likely be restricted to carrying a small warhead of about 20 pounds or less, necessitating a direct hit by a missile to achieve a kill of most targets. This, of course, is not always possible and limits the lethal effectiveness of the platform.

For a complete listing of the Predator's physical characteristics and performance specifications the reader is directed to Table 3.1 on page 48.

C. TIER II+

Like the Tier II that precedes it, the Tier II+ is an ACTD program run by the ARPA to demonstrate the capabilities of endurance UAVs in carrying out a variety of important military missions. Other commonalties between the Tier II+ UAV and its predecessor are the capability of carrying three different sensors at once (SAR, EO and IR) and the ability to communicate beyond the horizon using Ku band satellite relay. Despite the similarities the Tier II+ is a very different program from the Tier II. Perhaps the most obvious of these differences is that the Tier II+ (and Tier III-) is designed to operate at high altitude and utilizes newer technologies, some of which are unproven. For this reason both the Tier II+ and the Tier III- are longer range programs, with the Tier II+ representing a maximum performance type UAV and the Tier III- representing a UAV

with some degradation of performance in order to affordably integrate stealth technologies. For both the Tier II+ and Tier III- programs the primary objective is to develop a high endurance UAV system capable of continuous, all-weather, wide area surveillance at a fixed per-unit cost of \$10 million. [Ref. 22]

The Tier II+ program began in early 1994 with a notice to prospective contractors that the ARPA would be accepting proposals on a new high altitude endurance UAV. The competition for the Tier II+ project was unique in that unlike previous defense contract competitions the DoD was committed to not getting involved in the actual design and specifications. Instead the competitors were given a relatively short list of operational requirements for the UAV and told to utilize a "best business practices" approach to designing the most impressive UAV system possible given a maximum \$10 million per aircraft flyaway cost. The primary requirements given to the contractors were as follows:

- Takeoff from a 5000 foot military runway (usable by a C-130 transport) in a 20 knot crosswind and climb rapidly to a 50,000-65,000 foot altitude band within a 200 nm. corridor.
 - Flying 1,000-3,000 nm. to a desired surveillance area at 300-400 knots.
 - Loitering for at least 24 hours at altitudes up to 65,000 feet.
 - Searching 40,000 square nm. each day (1,667 square nm. per hour) and focusing on up to 1,900 point targets per day.
 - Synthetic aperture radar resolution of 0.3 to 1.0 meter at 55 nm. range, depending on the system's operating mode.
 - Transmission of SAR, EO and IR imagery to ground-based processing stations, either by direct communications or via aircraft relay or satellite links.
- [Ref. 23]

Of the 14 contractors that responded to the ARPA's request for proposal, five were awarded \$4 million contracts in October 1994 for six months of further design with

the understanding that the field would be narrowed to two contractors in the spring of 1995. However, because of budget cutbacks, the ARPA and DARO were forced to choose only one contractor and in July of 1995 Teledyne Ryan was chosen as the prime contractor for the Tier II+ HAE UAV project.

Teledyne Ryan's Tier II+ design (Fig. 3.3), with its 116-foot wingspan and 23,000 pound gross weight, is capable of staying aloft for over 42 hours with a more than 2100 pound payload. This very high performance design, which is still unnamed at present, utilizes a highly efficient turbofan jet engine that allows it a cruising speed of 350 knots true airspeed and a ferrying range of 14,400 nm. While this ferrying range allows the Tier II+ to fly essentially anywhere in the world from a given location, a typical mission profile would consist of flying a mission radius of 3000 nm. with a full 2100 pound payload and then loitering over a mission area for 24 hours before returning to its operational base. [Ref. 24,25]

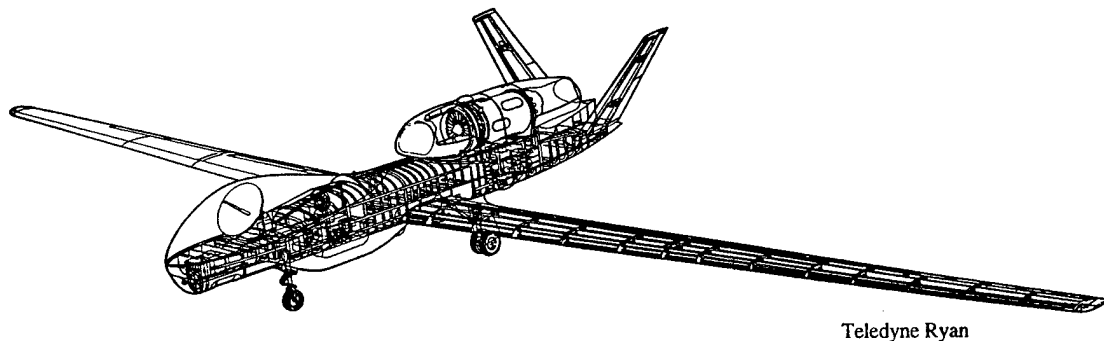

Fig. 3.3 - Tier II+ UAV

While the Tier II+ is by no means a stealth design, the aircraft does utilize several features to make it less detectable and more survivable. These include a specialized mission planning suite geared toward threat avoidance, a high altitude flight profile, a threat warning receiver, an on-board radar jammer and a wire-towed decoy system. In addition the Tier II+ utilizes both infrared and radar suppression, with the radar suppression most likely coming from radar absorbing materials. In fact, despite the UAV's

enormous size and bulbous nose (to accommodate a 4 foot satellite dish antenna) the Tier II+ is reported to have a radar cross section of as low as one square meter, dependent upon aspect at time of detection. [Ref. 25]

Navigation and control for the Tier II+ UAV is expected to be similar in most respects to that used by the Predator and current plans are for the Tier II+ and Tier III- to use a common ground control station. Communications with the Tier II+ will be accomplished via one of three ways, 1) a wide band, X-band line-of-sight channel capable of 137-274 Mbps, 2) a narrow band UHF satellite relay (2.4-19.2 Kbps) or 3) a wide-band, Ku-band satellite relay capable of simultaneous sensor data transmission at a rate of 20-50 Mbps. The Ku-band satellite relay is particularly impressive in that it will allow the transmission of imagery from any two of the UAV's three onboard sensors at a data rate that supports full motion video. While details are currently unavailable regarding any system for retransmitting imagery outside the tactical area, such as is done by the TROJAN SPIRIT II in the Predator UAV system, it is expected that both the Tier II+ and Tier III- will utilize this capability. [Ref. 26]

As mentioned previously, the Tier II+ is capable of carrying the same three sensor types carried on the Predator, a synthetic aperture radar, an electro-optics camera, and a FLIR camera. However, on the Tier II+, all three of these systems are improved. The SAR is capable of the same one foot spot resolution as that found in the Predator but can maintain that resolution at ranges of up to 110 nm. The Tier II+ SAR is also capable of covering up to 1900 point targets per day in spot mode and up to 1600 square nautical miles per day in the search mode. In addition, all SAR processing will be done onboard the UAV itself, a fact that allows the system to send greater sized areas of imagery via the Ku-band satellite data link and also allows for sending fully formed SAR imagery directly to ground troops. The Tier II+ electro-optical camera is also capable of 1 foot resolution and the system's FLIR is capable of a 2 foot resolution when used in spot mode at ranges of up to 15 nm. When combined with information from the UAV's navigational sensors the Tier II+ will be capable of locating targets to within 20 meters (66 feet) of a GPS

reference, whereas the Predator is currently only capable of 100 meter (330 foot) accuracy. [Ref. 26] For more information on the SAR, EO and FLIR planned for the Tier II+ the reader is directed to Chapter IV, UAV Sensors and Payloads.

Other payloads that have been considered for the Tier II+ include a laser designator, an automatic target recognition system, communications relay equipment, signals intelligence receivers, multispectral imagers and even weapons [Ref. 24,27]. In fact, the inboard section of the wings on the Tier II+ have been designed with hard points for just this purpose and the Army's Space and Strategic Defense Command is currently leading an effort to assess the feasibility of such weapons. [Ref. 27]

Because the contract for the Tier II+ was recently awarded the UAV is still in the design phase and the first two Tier II+ aircraft are not scheduled to roll-out of the factory until late in 1996 with the first flight of the Tier II+ scheduled for December of that year. Delivery of these vehicles and a single ground control station would then follow early in 1997 with the manufacture of eight more UAVs and two ground control stations in 1998 and 1999. Completion of the ACTD is scheduled to occur in 1999 and at that time military planners would make the decision to either transition the program into full production or pursue another alternative. Funds already committed to the program for fiscal years 1994 to 1999 total \$432 million. Current plans are for the UAV to be operated by the U.S. Air Force. [Ref. 24]

From a Lethal UAV standpoint the Tier II+ is a near-perfect platform for the detection and destruction of both fixed and mobile platforms. It has all the benefits of the Predator but is capable of carrying a bigger payload and has more accurate sensors. In addition, the UAV flies at a higher altitude making it less susceptible to most surface-to-air missiles (SAMs). With its bigger payload and two hardpoints which are rated at 1000 pounds each, the UAV is even capable of carrying precision munitions, such as laser guided missiles and bombs, that are already in the U.S. weapons arsenal. With smaller, specially designed missiles the scenario gets even better; that is, the UAV would most likely being capable of carrying as many "Scud killer" missiles as space would allow on

the two hardpoints. Best of all, with a fuel loadout of over 14,000 pounds the net effect of carrying 2,000 pounds less fuel in order to carry munitions is not detrimental; it would only decrease the UAV's endurance by about 6 hours, leaving 36 hours of endurance to transit and complete a mission. In fact, perhaps the only thing that would increase the capability of the Tier II+ as a Lethal UAV would be the addition of automatic target recognition, a feature that should not be too long in coming.

The only negative aspect of using the UAV for such a mission is its relatively high price tag when compared to the Predator, a fact that makes the platform less attractive for missions where the probability of attrition is high. Nonetheless, the Tier II+ is still many times cheaper than a comparable manned aircraft, involves no risk to a human operator, and with its specially designed survivability suite will undoubtedly be more survivable than the Predator.

For a complete listing of Tier II+ physical characteristics and performance specifications the reader is directed to Table 3.1 on page 48.

D. TIER III- : DARKSTAR

The Tier III- is an ACTD program run by the ARPA that has its origins in a now canceled Tier III program that, had it continued, would have produced a large stealthy UAV with capabilities exceeding those of the Tier II+. However, because of the nearly exponential relationship between stealth design and airframe size, the Tier III UAV would have had a per unit cost range of \$150-\$400 million, and was therefore deemed to be too expensive. Consequently, in early 1994 the Tier III- program was instituted with the objective of building on the prior Tier III investment of \$850 million to produce a smaller, high altitude, endurance UAV that is both affordable and stealthy. Because of the stealth design the decision was made at the outset to maintain the Tier III- as a classified project and thus by May 1994 a sole-source contract was signed with Boeing and Lockheed Martin to jointly design and build the Tier III- as part of a Special Access Required program. Like the Tier II+, the primary objective of the program was to build a

UAV under a limited set of guidelines, but at a fixed production cost of \$10 million per vehicle. However, unlike the Tier II+, the Tier III- would be reduced in its capabilities, a reality of the fact that low observable airframes are more costly to design and build. [Ref. 28,29]

The resulting air vehicle, now known as "Darkstar" (Fig. 3.4, next page), was unveiled in a ceremony on June 1, 1995 after the decision was made by the ARPA and DARO to declassify most aspects of the program in order to save money. With its slightly forward swept wings and unconventional dish-shaped fuselage the Tier III- is clearly unlike any airframe ever designed before. In fact, Darkstar is even different from previous stealth designs, with the primary reason for its uniqueness lying in the fact that the UAV was designed to be stealthy not just from the front, but from all directions. The reason for this radical shift in design is that the Tier III-, unlike previous stealth aircraft, will be required to loiter for hours over enemy territory to accomplish its primary mission of reconnaissance. Consequently, the Tier III- was designed so that it would have only two reflective "spikes" when highlighted by radar vice the four or more spikes found in traditional stealth designs. This represents the minimum radar signature possible in a winged aircraft design and will allow the UAV to loiter over high threat areas where the threat of being shot down by SAMs is too high even for UAVs like the Predator or Tier II+. [Ref. 30]

Unfortunately, because of its small, stealthy design the Tier III- is limited to a smaller payload and fuel capacity. Thus, despite the aircraft's 69 foot wingspan and high aspect ratio (14.8), Darkstar is limited to an 8 hour endurance when flying a 500 nm. mission radius with its standard payload of 1000 pounds. The gross takeoff weight for the UAV is 8600 pounds, about 3000 pounds of which is fuel. At its normal operating altitude of 45,000 feet the Tier III-, which is powered by a single Williams-Rolls turbofan engine, is capable of cruising at 300 knots true airspeed. The engine, which produces 1,900 pounds of thrust, is different from previous stealth designs in that it is not hidden by a curved duct in the front. From the rear though, the aircraft is similar to other stealth

designs (particularly the F-117) in that spreader vanes are used to broaden the flow of engine exhaust into a thin rectangle to reduce the UAV's IR signature. [Ref. 30]

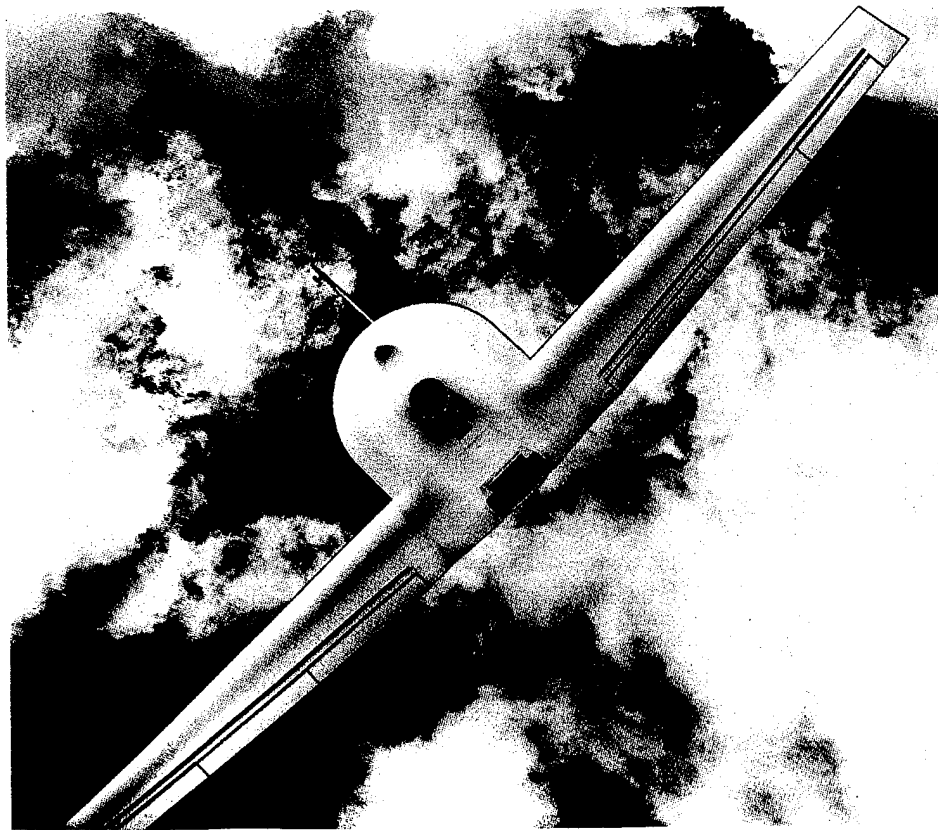

Boeing / Lockheed Martin

Fig. 3.4 - Tier III- UAV (Darkstar)

As mentioned previously, the Tier III- will use the same ground control station as the Tier II+, and navigation for the UAV will most likely be accomplished via an integrated GPS/INS unit. Like the Predator, the Tier III- will utilize a narrow (1.5 Mbps), Ku-band satellite data link for over-the-horizon communication. However, because of Darkstar's wider surveillance area it will be limited to sending only spot images vice full motion video imagery. Additionally, the UAV will have a wide X-band (137 Mbps) line-of-sight data link that will allow it to send full motion video imagery. As with the

Tier II+ it is expected that the Tier III- system will incorporate some means for sending reconnaissance imagery to other sights worldwide, such as is done by the TROJAN SPIRIT II station with the Predator. [Ref. 26]

Because of both its smaller payload and unusual shape the Tier III- is limited to carrying only one sensor at a time and current plans do not include any kind of IR sensor. The SAR that it will carry uses many of the same components as that used on the Predator, but includes low probability of intercept features which are appropriate for the Tier III- low-observable mission. This SAR, when compared to that found in the Tier II+, is capable of the same 1 foot resolution but is limited to only searching out the left side of the UAV and can cover only about one third the area (or number of spot targets) per day. Electro-optics resolution for the Tier III- is about two feet in the spot mode and targeting accuracy is identical to that of the Tier II+ (20 meters CEP with respect to GPS reference). [Ref. 26] For more information on Darkstar's SAR and EO sensors the reader is directed to Chapter IV, UAV Payloads and Sensors.

Because the contract for the Tier III- preceded that for the Tier II+ by more than a year, the Tier III- program is significantly farther along. As mentioned previously, the first of two initial vehicles was unveiled in June 1995 and current plans are to conduct a first flight in October 1995. The initial \$124 million contract with Lockheed Martin/Boeing covers the development and production of two UAVs, a basic ground control station and an initial phase of flight testing that is currently scheduled for completion during November or December 1995. Additionally \$35 million in the fiscal year 1996 budget has been set aside for the acquisition of two more Tier III- aircraft, but this money is expected to be targeted for budget cuts. [Ref. 22]

Current plans for the Tier III- are to continue flight testing into 1996 and then to demonstrate the UAV in one military exercise in 1996 and two in 1997. Then, most likely in 1998 or 1999 after additional demonstrations, the UAV would be considered for full scale procurement. [Ref. 22] Like any ACTD program, acquisition of the Tier III- would be based on feedback from operational units as well as on performance of the

UAV in either demonstrations or real world deployments. Like the Predator and Tier II+, the Tier III- will most likely be operated by a unit within the Air Force's Air Combat Command and the Air Force has already drafted a concept of operations that would include acquisition of all three platforms. The force structure study, which is based on having to fight two major regional conflicts simultaneously, proposes a force of 50 Tier II Predators, 20 large-payload Tier II+ UAVs and 20 stealthy Tier III- Darkstars. In fact, a funding wedge is being considered for FY 1997 budget plans with \$750 million to be invested over the following six years. [Ref. 24]

From a Lethal UAV standpoint the Tier III- would make an excellent targeting platform with the addition of a laser designator, however because of the limited payload and stealthy shape, carrying strike weapons is not an option for the UAV. The primary value of the Tier III- then, would be in locating and designating high value targets over heavily defended enemy territory, thus allowing access to places that the Tier II or Tier II+ could not go. With the targets designated a second UAV or a manned aircraft could then fire a stand-off weapon to destroy the target. In fact, in heavily defended areas this might be the only way to locate and destroy a Scud or other mobile target, making the Tier III- a unique real-time targeting asset worth pursuing.

For a complete listing of Tier III- physical characteristics and performance specifications the reader is directed to Table 3.1 on the following page.

CAPABILITIES	TIER I	TIER II	TIER II+	TIER III-
Gross Take-off Weight	1126 lbs	1873 lbs	22,914 lbs	8600 lbs
Wingspan / Length	35.3 ft / 16.3 ft	48.7 ft / 26.7 ft	116.2 ft / 44.4 ft	69 ft / 15 ft
Propulsion	85 hp recip. engine	85 hp recip. engine	Allison AE3007H turbofan	1900 lb thrust turbofan
Maximum Endurance	40+ hours	50+ hours	42+ hours	8+ hours
Ferry Range	3000+ nautical miles	6000 nautical miles	15,000 nautical miles	3000+ nautical miles
Mission Duration at Operating Radius	24+ hours on station at 500 nautical miles	24+ hours on station at 500 nautical miles	24 hours on station at 3000 nautical miles	8+ hours on station at 500 nautical miles
True Airspeed	60-120 knots (IAS)	60-110 knots (IAS)	350 knots at 65,000 ft	300 knots at 45,000 ft
Maximum Altitude	25,000+ ft	25,000+ ft	65,000 ft	45,000+ ft
Survivability Measures	Reduced Radar & IR Signature	Reduced Radar & IR Signature	Threat Warning & ECM	Very Low Observable
Command & Control	UHF MILSAT/ LOS Autonomous	UHF MILSAT/ LOS Autonomous	UHF/VHF MILSAT LOS/Autonomous	UHF MILSAT/ LOS Autonomous
Normal Payload Wt.	140 lbs	450 lbs	2000 lbs	1000 lbs
Sensors	EO: 1.5 ft. resolution IR: NIIRS 6 Simultaneous Carriage	SAR: 1 ft resolution 3300 ft width swath EO: 1.5 ft. resolution IR: NIIRS 6 Simultaneous Carriage	SAR: 1 ft resolution 2x2 km swath (spot mode) EO: 1 ft. resolution IR: 2 ft. resolution Simultaneous Carriage	SAR: 1 ft resolution 2x2 km swath (spot mode) EO: 2 ft. resolution Single Carriage
Coverage per Mission	unknown	13,000 sq. NM (search)	40,000 sq. NM (search) or 1900 spot images	14,000 sq. NM (search) or 620 spot images
ATC Communications	IFF	UHF repeater IFF	UHF/VHF repeater IFF Modes 3A, C & 4	IFF
Data Transmission	LOS: C-band	Ku-Band & UHF SATCOM: 1.5 Mbps LOS: C-band	Ku-Band & UHF SATCOM: 20-50 Mbps with Simultaneous Sensor Transmission LOS: X-band 274 Mbps	Ku-Band & UHF SATCOM: 1.5 Mbps LOS: X-band 137 Mbps
Deployment	2 C-141s or Multiple C-130s	2 C-141s or Multiple C-130s	2 C-141s or Multiple C-130s	Self-deployable, Support Equip. requires airlift

Table 3.1 - Tier Programs Comparison

IV. UAV SENSORS AND PAYLOADS

While UAV airframes have evolved considerably since the use of the Ryan 147 drone in Vietnam, it is primarily gains in the design of sensors and payloads that have allowed UAVs to become an inexpensive, effective solution to the U.S. military's reconnaissance needs. In fact, in at least one previous UAV program (the Air Force's Compass Cope in the 1970's) it was a lack of technological maturity in this area that ultimately lead to the program termination of a very capable airframe [Ref. 3]. Today, thanks to the miniaturization of electronics made possible by very-high-speed integrated circuits (VHSIC), there exists a number of small, lightweight sensors made specifically for UAVs, and payloads are being designed in increasing numbers as well. The primary sensors used on advanced UAVs such as those in the Tier program are electro-optics (EO), infrared (IR or FLIR) and the synthetic aperture radar (SAR), each of which will be discussed in detail. Additionally, other types of sensors and payloads will be discussed with emphasis placed on those most likely to be used on a Lethal UAV.

A. ELECTRO-OPTIC SENSORS

Nearly all UAVs have some sort of electro-optic camera, with the most basic of them carrying simple off-the-shelf TV cameras and more complex UAVs utilizing stabilized, gimbal-mounted high-power lenses with electronic stabilization and magnification. Of course, the more features a camera has, the higher its price and this is particularly true of the cameras used on UAVs, with features like gimbal mounting and stabilization driving the cost way up. Thus, state-of-the-art EO/IR packages like the \$350,000 Skyball are usually reserved for more expensive, capable UAVs like the Predator (and GNAT-750). However when a more capable sensor package like Skyball is combined with an accurate navigation system like the Predator's embedded GPS/INS, the result is a platform that can be used for long range precision targeting.

The Skyball platform (Fig. 4.1, next page) that houses the Predator's two high resolution color cameras is a 14-inch four-axis gyrostabilized platform capable of continuous rotation in the azimuth plane and 90 to 120 degree movement in the elevation plane. The platform houses both an IR imager and a laser range finder in addition to two EO cameras and is stabilized down to an RMS error of 10 microradians, a critical specification that should guarantee the Predator's future success as a precision targeting platform. In fact, while current estimates are that the UAV can only locate a target to within 100 meters, project officials working with the Predator are hoping to achieve a targeting accuracy of within 10 meters when used at closer ranges [Ref. 31].

The two cameras carried in the platform are a primary daylight television camera with a 10X zoom and a 900 mm. fixed focal length spotter scope. The primary lens is used for searching broad areas and has a field of view (FOV) that zooms from a width of 20 degrees down to a narrow 2 degrees. The spotter scope has a 0.4 degree FOV and an extremely fine resolution that allows it to discriminate 18 inch items from 15,000 feet. [Ref. 31,32] This capability gives an operator the ability to identify a person at up to 2-3 miles, a feature that could be particularly handy in a hostage rescue type mission. It can also be used by an analyst to tell such things as the difference between calibers of artillery or whether small vehicles are equipped with weapons. [Ref. 18,20]

Like the Predator, the Tier II+ will be capable of carrying both EO and IR sensors simultaneously, but in the case of the Tier II+ the sensors are more highly integrated, even to the point of sharing the same telescope. Consequently the sensors have two main operating modes—wide-area search, and spot, in common. Wide-area search covers a 10 km. wide strip at about 300 knots with a three foot resolution at ranges up to about 50 km. The spot mode views a 2 x 2 km. patch and can resolve details to within one foot when used at ranges up to 28 km. The turret (Fig. 4.2) that houses the cameras is different from Skyball in that it is limited to a 45 degree viewing angle in azimuth about either the left or right side and thus cannot be used to present head-on views of the Tier II+ UAV's path. However the integrated system, which is made by Hughes Electro-

Optical Systems, has an improved stabilization of three microradians RMS error (vice 10 microradians for the Skyball) which when combined with information from the UAVs embedded GPS/INS navigation unit will allow it to locate targets to within 20 meters of a GPS reference at ranges up to 30 km in either the EO or IR mode. [Ref. 26]

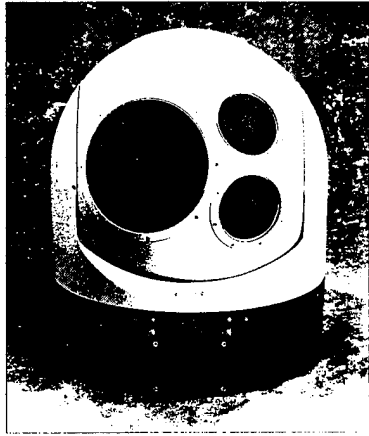

Versatron Corp.

Fig. 4.1 - Skyball Turret

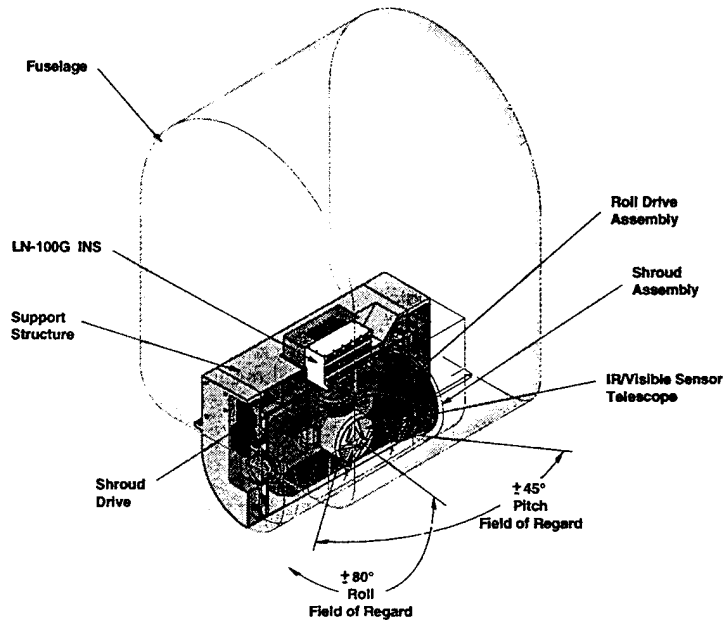

Fig. 4.2 - Hughes' Tier II+ Turret [Ref. 26]

The capabilities of the EO system on the Tier III- are similar to those of the Tier II+ but different in that the system is only capable of carrying one sensor at a time and is limited to looking out the left side of the UAV, a restriction imposed primarily by the stealthy design of the aircraft. The EO camera which is made by Recon/Optical, Inc. uses the same two mode approach as the Tier II+, utilizing a 2 x 2 km. patch in the spot mode to resolve details down to within 2 feet at ranges comparable to those of the Tier II+. Details about the system's wide-area search mode are not known, but like the Tier II+ the Tier III- should be capable of locating targets to within 20 meters of a GPS reference. [Ref. 26]

B. INFRARED SENSORS

Infrared sensors, because of their ability to “see” clearly at night and in light fog, haze or dust, have for many years been used to great tactical advantages on nearly all modern, manned attack aircraft. They have also been used successfully on a number of manned reconnaissance aircraft, and with recent reductions in component size are now being used on most military UAVs. Today many IR sensors designed specifically for use in UAVs are combined with EO sensors in a multi-sensor turret such as Skyball. Most of these systems weigh between 50 and 100 pounds (with EO cameras included) but some stand-alone IR systems have been developed that weigh as little as 10 pounds [Ref. 33]. As mentioned previously, features like gimbal mounting and gyro-stabilization tend to drive up the price of these systems and consequently those systems most likely to be used for precision targeting are found only on higher priced, more capable UAVs.

The IR sensor used in the Skyball platform (Predator and GNAT-750) is a 3-5 μm Platinum Silicide staring array infrared imager with six field of view optics ranging from 1 degree (for long stand-off viewing) to 38 degrees (for landing purposes). This sensor delivers “TV-like” images in visibility conditions ranging from full daylight to total darkness and has already been used on the Predator in U.S. military exercises to successfully locate camouflaged, mobile missiles at night. The system uses a 512 x 512 pixel chip and is capable of a resolution comparable to that of the EO sensors it is housed with, that is, about 18 inch resolution at a range of 15,000 feet. [Ref. 32]

As previously mentioned, the IR system designed by Hughes on the Tier II+ is integrated with the UAV’s EO sensor and thus, like that sensor, has both a wide-area search mode and a spot search mode. The system is designed to deliver a three foot resolution in the search mode and a two foot resolution in the spot mode at ranges up to 28 km. Like the IR sensor used by the Predator, the Tier II+ IR sensor detects thermal images in the 3-5 μm band, but uses a 640 x 480 pixel, Indium Antimonide chip to do it. [Ref. 26]

C. SYNTHETIC APERTURE RADAR

While EO sensors generally present the easiest imagery to interpret and IR sensors provide affordable coverage at night and in light weather conditions, only radar can provide the kind of long range, all-weather coverage that will guarantee timely imagery to an area commander regardless of external phenomena. Thus there has been a push, in recent years, to make radar components smaller and smaller in the hopes that they will be incorporated into UAVs. In fact, both AIL Systems and Lockheed Sanders have developed moving target indication (MTI) radars that weigh 100 and 125 pounds respectively for use on smaller UAVs such as the Hunter [Ref. 33]. However for detection of stationary targets this is not sufficient and the radar of choice for modern UAVs is the synthetic aperture radar (SAR). Because it relies on relative motion between the radar and its target, the SAR is particularly well suited to air vehicles and with sufficient computer processing available the SAR is able to provide exceptional resolution (1 foot) at extremely long ranges (200 km on UAVs). Of course, because of the substantial processing power required, this capability does not come cheaply and therefore SARs are being considered for only the more expensive, most capable UAV systems.

The SAR system currently being flight tested on the Predator (for operational use by December 1995) is built by Westinghouse Electric and is a 170 pound derivative of the SAR designed for use on the Navy's canceled A-12 attack aircraft. This radar is one of the first operational SARs to offer 1 foot resolution from 15,000 feet at a 6.2 mile slant range, an accomplishment that requires an exposure time of 5 to 6 seconds. Consequently in order to produce an image that is processed correctly, the system relies heavily on its tight integration with the UAV's sophisticated embedded GPS/INS navigation to compensate for the aircraft's movements due to maneuvering, turbulence and vibration during that time span. [Ref. 20]

The SAR system that is to be carried by the Tier II+ is built by Hughes Radar and has three distinct modes of operation—wide-area search, spot, and ground moving target

indicator. Because the SAR and EO/IR systems are controlled by the same processor, the wide-area search and spot modes on the Tier II+ operate as described previously and the resolutions for the SAR are three feet and one foot respectively. However, whereas the maximum range for the EO/IR sensors is 50 km. in the search mode, the SAR can cover a 10 km. wide strip that is anywhere from 20 to 200 km. to the side of the UAV. In the spot mode the SAR has a resolution of one foot even at ranges as great as 200 km. Additionally, like the EO/IR system, the SAR can be used to pinpoint the location of a target to within 20 meters of a GPS reference. However, when using the SAR the system can resolve the location at ranges as great as 100 km. vice only 30 km. with the EO/IR system. The third mode used by the SAR is a ground moving target indicator mode that is particularly useful in detecting tanks, trucks and mobile weapons platforms. In this mode the system has a resolution of 10 meters at ranges up to 200 km and an operator can use this mode to initially detect a target and then hand it off to the spot mode for more detailed viewing. [Ref. 26]

In addition to the three modes described above, the Tier II+ radar system has some additional features that make it considerably more capable than previous radars. One such feature is the fact that the system has been designed to do its image processing onboard the UAV rather than on the ground. This not only reduces the data link demands of the system by a factor of 8 to 10; it also allows the UAV to send fully formed SAR imagery directly to front line troops carrying only a basic line-of-site or satellite receiver. In addition the system is set up such that the UAV can operate and transmit from two of its three sensors at once. This will allow the UAV to either look in two different areas simultaneously or to observe the same area with different sensors. This sensor fusion has been proven to make target identification easier and also has the added benefit of allowing operators-under-training to recognize targets on the SAR when they are simultaneously presented on the more familiar EO. [Ref. 26]

The SAR being built-up for the Tier III- has many of the same components as that used on the Predator but has incorporated low probability of intercept measures to make

the system appropriate for low observable missions. Like the SAR on the Tier II+, the Tier III- SAR built by Westinghouse, utilizes a 2 x 2 km. swath when in the spot mode and is able to resolve target details to within one foot of resolution. While details have not been released about other modes, it is believed that the SAR also has a search mode similar to that found on the Tier II+ SAR but with a lesser sized coverage. Targeting accuracy for the Tier III- is expected to be about the same as that for the Tier II+, that is, within 20 meters of a GPS reference. Like the EO sensor that the Tier III- carries, the SAR is limited to looking out only the left side of the UAV, a restriction that must be taken into account when mission planning is done. [Ref. 26]

D. DATA LINKS

While sensors are indeed critical to the effectiveness of any flying aircraft, it is the two-way data link that gives UAVs their unique near-real time data collection capability. By being able to monitor and control both the flight path of and sensors used by the UAV as it is flying, an operator is able to react to both changes in mission tasking and in the external environment that the UAV is flying in. This is particularly critical when using endurance UAVs because of the increased probability of a change in either tasking, ground battle damage or enemy movement during the long flight times involved. Thus, while all four Tier UAVs have a preprogrammed mode, they can each also be either reprogrammed in flight or flown remotely to allow for the changing circumstances mentioned above. This, of course, is done via the data link, and each of the four Tier UAVs is able to communicate with its ground control station via military satellite relay, thus enabling over-the-horizon operation.

Additionally, the Tier II, Tier II+ and Tier III- UAVs are able to send video imagery back to their ground stations via commercial Ku-band satellite relay. This further refinement allows the UAV operator to respond to the UAV's environment even when over-the-horizon and could very well be used to protect the UAV from a menacing

thunderstorm, or in the case of a Lethal UAV, could be used to provide human verification of a target prior to a command being given to destroy that target.

The Ku-band satellite relay used by the Predator has a data transmission rate of up to 1.5 megabits per second (Mbps) and at that rate is able to transmit near-real time video imagery by using compression techniques to reduce the amount of data being transmitted. It is expected however that this data rate will eventually be increased to allow the transmission of uncompressed data to improve image quality. [Ref. 18]

The Tier II+ will also use a Ku-band satellite relay, but at a data transmission rate of 50 Mbps. However, because of the greater sized search area looked at by the Tier II+, JPEG data compression will still have to be employed to allow near-real time video imagery from the EO in the search mode. In the spot mode the data link requirements become even more stringent and with the use of data compression techniques the UAV will require 45 seconds to send 10 seconds worth of EO imagery. Because of onboard processing, data link requirements for the SAR imagery are fairly benign. Thus compressed radar imagery, which only takes up 8 Mbps of the total 50 Mbps capacity can be sent simultaneously with the EO imagery. Likewise, compressed IR imagery is also relatively compact and can be sent along either with the EO imagery or by itself at a lesser compression rate to improve clarity. [Ref. 26]

The Ku-band satellite data link planned for use on the Tier III- has a small low observable antenna that reduces the chance of the UAV's communications being detected by enemy forces. However a bandwidth of 1.5 Mbps limits the UAV to sending only spot imagery, though program officials say that it can be upgraded to 50 Mbps [Ref. 26].

When operating line-of-sight (LOS) to a ground station, both the Tier II+ and Tier III- utilize an X-band channel that gives the Tier II+ a 274 Mbps data rate and the Tier III- a 137 Mbps data rate. This, of course, greatly reduces the amount of data compression required thereby producing significant enhancements in image quality. Both the Tier I and Tier II also have a LOS mode (C-band) but specific data rates are not known.

E. OTHER PAYLOADS

Other payloads that have been considered for use on the Tier UAVs include the following: laser designators, automatic target recognition, multispectral imagers, sensor-to-cockpit transmitters, survivability suites, electronic countermeasures devices, communications relay equipment and signals intelligence receivers. [Ref. 18,20,24,29] Of these eight items the first five are deserving further mention in that they might be used to enhance the effectiveness of a Lethal UAV.

Laser designators are perhaps the easiest way to ensure that a missile or glide bomb in its terminal phase will hit its intended target. In fact, while there are currently no solid plans to design or build any weapons carrying Lethal UAVs, both military and congressional leaders have been trying to ensure that the current generation of UAVs will include a laser designator capability that could be used in conjunction with either cruise missiles or precision guided weapons carried by manned aircraft. By utilizing this approach military planners would have at their disposal a UAV that could fly deep in to heavily defended enemy territory, locate and identify a mobile target, and then maintain a laser beam on that target. At that point a stand-off weapon would be launched into the area so that it could acquire the laser beam and track along its path to intercept and kill the target. Of course, the primary advantage of this approach is that it would allow the best possible targeting of a mobile weapon system without the normal risk associated with sending in a manned aircraft close enough to locate, identify and laser designate the target. However, it should be noted that in the time it takes for a stand-off weapon to arrive and begin tracking the laser beam, a mobile weapons platform such as a Scud missile system would have time to fire one if not more ballistic missiles. This, of course, is the primary reasons why the concept of a Lethal UAV carrying its own weapons is so important.

Automatic target recognition is a relatively simple problem when a sensor-processor network knows exactly what weapon it is looking for and at what angle it will be approaching the target from. In fact this is essentially the basis of the terrain

comparison mapping system that has been successfully used in the U.S. Navy's Tomahawk cruise missile. However, for a UAV that is out searching for one or more types of mobile ballistic missiles the problem is a more difficult one. This is primarily because a mobile missile, launcher and transport system will look very different to the UAV's sensors depending on what angle it is approached from. Additionally, unlike the Tomahawk which is programmed to go after one or two types of specific targets at predefined locations, a UAV doing an area search should ideally be able to automatically identify a number of mobile targets at previously unknown locations if its automatic target recognition is to be considered effective.

Despite these seemingly insurmountable challenges, there is ongoing research into the area of "smarter" target recognition systems and UAV planners expect to eventually include such systems on UAVs although the questions of "when" and "at what capability level" remain to be answered [Ref. 20]. Initially, such a system would most likely offer only a limited capability, and thus would require final analysis by human operators (reviewing the sensor imagery via data link) to determine if, in fact, a real hostile target had been located. None-the-less this would be of immeasurable worth to a team of imagery analysts that would otherwise have to closely monitor every bit of imagery received by a UAV to determine whether or not a hostile target is present. Eventually however, such a system might be designed with sufficient reliability that a Lethal UAV could be sent out on an autonomous "Scud-hunting" or other lethal mission. This mission could entail detecting a target, positively identifying the target as hostile and then making a decision (based on the current rules of engagement) to either attack the target or simply transmit imagery of the target back to area commanders via satellite relay.

Multispectral imagers are significant to the mission of Lethal UAVs in that such a system would allow imagery analysts to look beneath lightweight objects like tree cover or camouflage to detect heavier objects such as enemy weaponry. This is particularly significant when searching for mobile Scud-type ballistic missile launchers as evidenced

by the Gulf War in which manned reconnaissance flights were unsuccessful in locating Scud missile launchers hidden by camouflage.

Sensor-to-cockpit transmissions by UAVs are relevant in that this would allow a UAV that has located a target to provide imagery of that target to any manned attack aircraft that might be flying in the area. Then using either a UAV mounted laser designator or a Latitude-Longitude position for the target calculated by the UAV, the manned attack aircraft could, after positively identifying the target, fire a stand-off weapon at the target. While similar to the scenario presented in the previous discussion on laser designators, a scenario that included sensor-to-cockpit transmissions would provide more timely destruction of a target by eliminating a step in the communication process and by utilizing aircraft already on station nearby.

The last of the five payloads to be discussed are survivability suites and these would be included on most any Lethal UAV system out of pure necessity. This is primarily because any practical Lethal UAV platform when loaded with weapons will produce a radar signature that does not allow it to remain undetected for very long. Thus, in order to perform a mission with an acceptable probability of survival a UAV must be armed with items that will allow it to defeat both radar and the missiles guided by radar. The Tier II+, even though designed to cruise at altitudes where most missiles cannot reach, is a perfect example of this. Because, in fact, there are a few Russian built SAMs (SA-5, SA-10 and SA-12) that can reach to above 70,000 feet, the Tier II+ has been outfitted with a survivability suite that includes defensive radar jammers, towed decoys and a radar warning receiver. This suite will allow the UAV to fly an effective reconnaissance and attack profile that includes not only avoiding lethal weapons envelopes but also surviving flights through them when necessary. [Ref. 25]

F. WEAPONS

Of course, without weapons a Lethal UAV is simply a UAV and thus this section will point out some of the current and future weapons technology that could be used to

effectively arm a fleet of UAVs with various payload capacities. Weapons that could be used on a Lethal UAV can basically be grouped into one of two categories—specially designed weapons and military off-the-shelf (MOTS) weapons. For UAVs with smaller payloads, like the Predator and GNAT-750, one is limited primarily to specially designed weapons because most applicable MOTS weapons weigh 500 pounds or more each. Exceptions to this include a couple of different models of lightweight anti-tank weapons which will be discussed below. UAVs with larger payloads like the Tier II+ could carry either category of weapons, although specially designed weapons could obviously be carried in greater quantities and would thus afford the UAV the opportunity to either fire several weapons at one target or to fire one or two weapons at each of several targets. In certain situations this second option might allow the UAV a higher probability of kill.

Specially designed weapons for UAVs would include kinetic kill vehicles such as the TALON missile described in Chapter II as well as small (50-150 pound) bombs and missiles that would be used against ground targets. While trade-offs have to be made between range and warhead mass on missiles of any size, in some cases, such as when attacking relatively fragile missile launchers, warhead size could be reduced, thus allowing for maximum missile range. This reduction of warhead mass is particularly critical when designing missiles of this size if one expects to have any appreciable stand-off range. Additionally, because of the smaller warheads involved in bombs and missiles of this size, precision terminal guidance becomes perhaps the most critical component in ensuring acceptable levels of destruction. As mentioned previously, when firing at ground targets the laser designator offers the best possible solution to the problem of both mid-course and terminal guidance and one would expect UAV missiles to incorporate this relatively simple method of guidance.

Kinetic kill vehicles on the other hand, because they are used against missiles already fired, would be best served by either an IR seeker or millimeter-wave radar. These weapons are also being designed with laser radars and laser rangefinders. [Ref. 14] Again, like the air-to-ground missiles these air-to-air missiles need to conserve every

ounce of weight possible for carrying fuel, and thus would probably benefit most from using small shaped charges designed to puncture and explode the fuel tank of a ballistic missile in its boost phase.

Laser guided bombs (LGBs), though limited in range, offer the benefit of being mostly warhead mass and thus could be used against larger, more hardened targets. With lightweight control surfaces that respond to the laser guidance, these weapons are just as accurate as their missile counterparts and when fired at higher altitudes and airspeeds can offer limited, if not acceptable, stand-off ranges. In fact, a UAV traveling at 200 knots up at 25,000 feet (Predator) should be able to "toss" a LGB up to 2.2 nm., and a high altitude UAV such as the Tier II+ should be able to drop a LGB from 65,000 at 350 knots, maintaining a stand-off distance of up to 6.2 nm. In addition, glide bombs (or missiles) can be outfitted with GPS/INS controllers, but this is currently only recommended with larger warheads as the circular error probable (CEP) for such guidance is only to within 10-15 meters.

MOTS weapons that could be used on smaller UAVs include both the TOW (47 pounds) and Hellfire (101 pounds) anti-tank missiles. These missiles have been used successfully for years on helicopters and recent versions of both weapons include laser guidance. However, because of the smaller size of these missiles they are limited to relatively short stand-off ranges—2.2 nm. for the TOW and 4.3 nm. for the Hellfire. [Ref. 34]

Larger MOTS weapons that would be restricted to use on Tier II+ sized vehicles include the GBU-12, a 500 pound laser guided bomb, and the AGM-65E (Maverick), a 650 pound laser (or TV) guided missile. Ranges for these weapons are 6.2 nm. and 10.8 nm respectively. In addition, a 500 pound GPS guided bomb is currently under development and expected to be operational by about the year 2000. [Ref. 34]

New missiles that are currently under development include the LOCATM (Low Cost Advanced Technology Missile) and the TACAWS (The Army Combined Arms Weapon System). The LOCATM is a mid-sized missile (300 pounds) with a 22 nm.

range and the TACAWS is a smaller sized missile, designed to replace the Hellfire and TOW, that weighs only 66 pounds and has an expected lethal range of 6.2 nm. [Ref. 34]

In addition, there are various packages that could be built up and added to a standard 250 pound bomb (Mk-81) to convert it to either a GPS guided bomb, a laser guided bomb, or a short range laser guided missile. These conversions are currently done with the larger Mk-80 series bombs and it would be simply a matter of scaling the components down to fit the smaller Mk-81. The advantage of such a conversion with a Mk-81 bomb is that it would allow a Tier II+ UAV to carry three or four of these weapons per wing station, as opposed to only one or two of the current MOTS weapons.

V. LETHAL UAV FEASIBILITY AND EMPLOYMENT

A. LETHAL UAV FEASIBILITY IN GENERAL

As stated in Chapter I this thesis was written to support design work [Ref. 35] already done by the author and other graduate students in which computer simulation was used to provide a proof of concept for the use of a non-specific UAV in a lethal role. This Lethal UAV simulation was developed at the request of the Operations Research Department at the Naval Postgraduate School as a means of validating the overall concept of using UAVs to detect and destroy theater ballistic missile (TBM) launchers.

The actual scenario used is detailed in [Ref. 35] and involves a Lethal UAV in an autonomous mode that loiters in a holding pattern over enemy territory. This UAV receives cueing and tracking information from a series of acoustic sensor modules on the ground. Once cued, the UAV maneuvers to an appropriate heading for firing a lightweight (50 lbs), supersonic missile at the target and fires the missile when it has closed to within a 12,000 foot slant range of the target. The missile then accelerates toward the target during a 10 second boost phase, all the while continuing to receive updates on the target's current position directly from the ground sensors via data link. These position updates are compared with an integrated GPS/INS system onboard the missile that provides a record of the missile's current position. With this information, the missile is able to use a PID Line-of-Sight controller to guide its way to the constantly updated position of the target.

The system model used in the simulation is coded in SIMULINK, a graphics environment developed by the *Mathworks Corp.*, that allows a user to model and simulate a system using standard block diagrams and control systems conventions. The environment is designed to work alongside MATLAB (also developed by *Mathworks*), a matrix manipulation tool that has become an industry and academic standard for solving both linear and non-linear systems of equations. Because of the modular nature of the

SIMULINK environment, the simulation is made up of several components and user defined MATLAB routines that all work together to achieve a desired effect. To illustrate this point a diagram of the complete Lethal UAV Model used in the simulation is presented below in Fig. 5.1, and one can see that there are several different major control blocks involved.

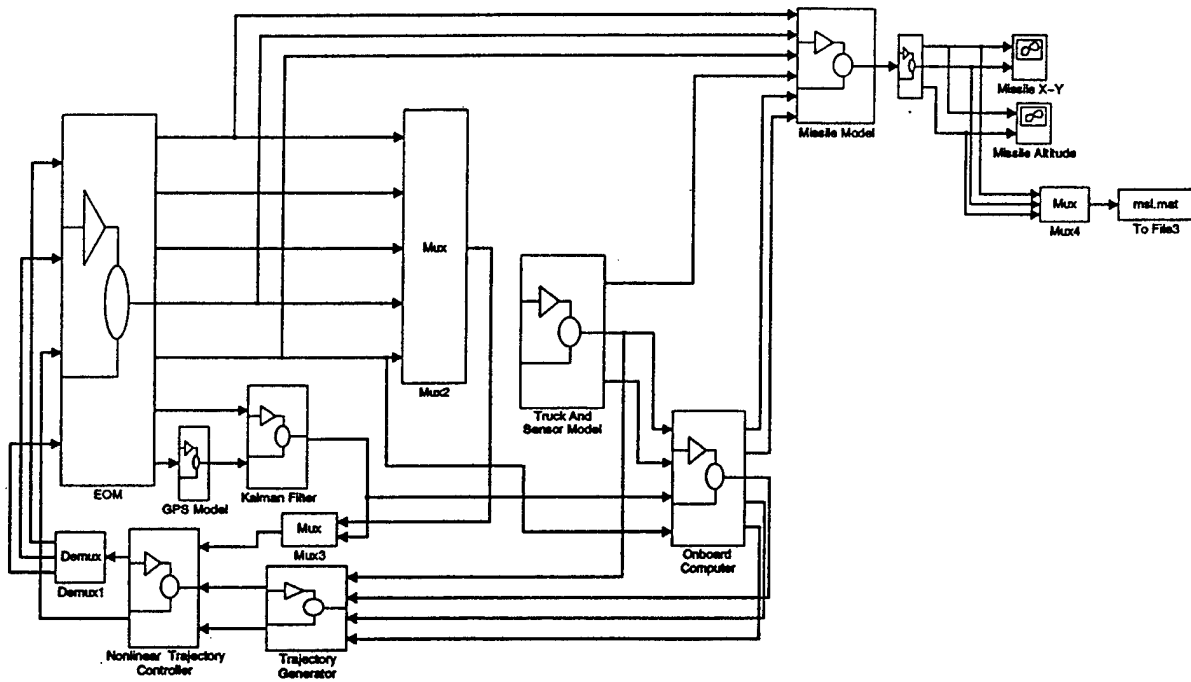

Fig. 5.1 - Simulation Model for Lethal UAV System (Complete) [Ref. 35]

Additionally, within each of these blocks are groups of sub-blocks, many of which are tied to either MATLAB predefined or user defined functions. The model also relies on information derived from the MATLAB workspace and from MATLAB data files which can be changed to suit the particular scenario being simulated. Thus, while stability and control derivatives for a non-specific, fixed wing UAV is currently coded in the model, this data could be changed to accommodate the derivatives of a real world UAV such as the Predator or Tier II+. To illustrate this point a diagram of the Equations of Motion

(EOM) block for the UAV is included below in Fig. 5.2. The MATLAB function labeled “dstate” in this diagram is actually a user defined function and relies on information obtained through a data file named “Bluedat.m”. As implied above, the procedures for changing this data is relatively straight-forward – it simply involves updating the stability and control matrices in the file to include the derivatives for the new air vehicle in question.

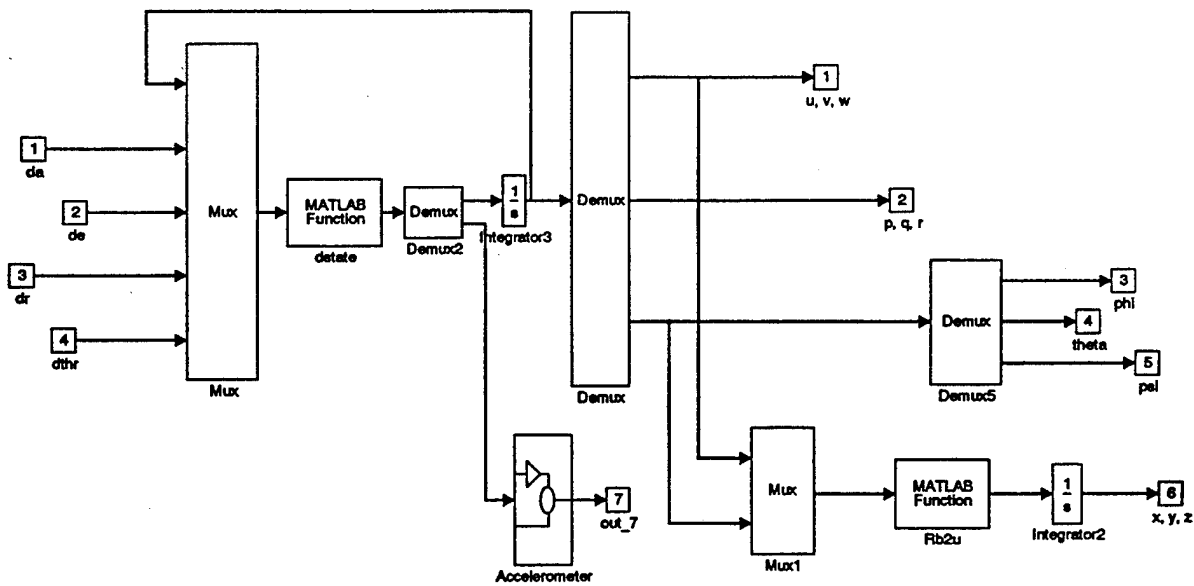

Fig. 5.2 - Equations of Motion Model Used in Lethal UAV Simulation [Ref. 35]

Additionally the modular nature of the model is particularly useful in that it allows one to modify or add a module without disrupting the entire model. This is perhaps best exemplified by returning to the complete Lethal UAV model (Fig. 5.1, previous page). While the scenario originally used called for using acoustic ground sensors to alert the UAV to the presence of a target, the “Truck and Sensor Model” block in the model could be removed and replaced with a block modeling an onboard sensor such as a FLIR or SAR. In this manner the simulation model could be updated to accurately simulate a real world UAV being used to detect and destroy a TBM system.

Results from simulation runs using the non-specific, fixed wing UAV in the scenario show that for a system with both GPS receiver clock and selective availability errors the average missile miss distance is on the order of about 40 feet. That is, during simulation runs of the model, missile miss distance varied from 20 to 60 feet, depending on the initial positions chosen for both the UAV and the target. While the GPS errors selected for use in the model are decidedly low (1 nanosecond of receiver clock error and 20 meters of selective availability error), the model does provide an adequate proof of concept for a Lethal UAV system in its most basic form. Additionally, if one has enough data on each of the components in a real world Lethal UAV system, these components can be modeled individually, combined in an overall simulation model and used to provide a proof of concept for a specific Lethal UAV system.

B. MISSIONS MOST LIKELY FOR UAVS

Given this general proof of concept and the bulk of evidence already presented on how the current and next generation of UAVs could be adapted for a lethal role, the next logical question would be, "What kind of lethal missions are UAVs best suited for?" A logical answer, it would seem, would be to use Lethal UAVs in the roles for which they are most uniquely suited, that is, those roles that would use their exceptional endurance, their ability to provide near-real time imagery, and their ability to fly over hostile areas at no risk to a human operator. To use a UAV in a role that a manned aircraft could do as well or better would most certainly be a waste of military assets. Additionally there are several missions currently done by cruise missiles that UAVs could take over, but again this would most likely be a waste of assets given the relatively low cost of cruise missiles and the high-risk missions they are usually tasked with. Thus, when one considers these factors and looks at the various missions available, there are two primary lethal missions which UAVs seem most uniquely equipped to handle.

The first mission which Lethal UAVs should be designed for is the location and destruction of mobile weapons platforms, whether they be theater ballistic missile (TBM)

systems, surface-to-air missile (SAM) systems or some other type. Because the location of these platforms is often unknown they are frequently impervious to preplanned attacks, such as are commonly carried out by manned aircraft or cruise missiles. Furthermore, in the case of TBMs the missile system is generally kept hidden until shortly before launch time, a strategy that makes their detection and destruction all the more difficult. In fact, barring other factors such as UAV survivability, it could probably be said that "hunting" TBMs would be a UAV's (or any aircraft's) most difficult mission. Thus, it would seem, that if the U.S. military were to focus attention on designing UAVs for this purpose, that with merely a change in tactics and weaponry that those same UAVs could carry out the less challenging mission of "hunting" SAMs or other weapons platforms. This, of course, would only hold for UAVs that are at least moderately survivable against SAMs, and thus would shift the emphasis away from less survivable designs like the Pathfinder and toward more survivable designs like the Tier II+ or Predator.

A second mission that Lethal UAVs are envisioned for would be in situations where some, but not all, information is known about a target. An example of this might be a planned strike in an area where the enemy is known to be holding hostages. In this scenario a UAV could make a first pass to gain more information about an area and then with the assurance that no hostages are in the area of attack, the remote operator could give the UAV a command to either carry out a preplanned attack or to make appropriate modifications to a preplanned attack. Again, because of the likelihood that there would be SAMs or other hostile weapons in the area, a more survivable UAV like the Tier II+ or Predator would be preferred. In fact, a stealthy UAV like the Tier III- could be used on such a mission, with the Tier III- flying in closer for reconnaissance and targeting and a Lethal UAV like Tier II+ or Predator standing-off and destroying the target with long range weapons.

While this "unknowns" mission is certainly a valuable one, because of the many possible variables and scenarios involved, further examination of this second mission type is beyond the scope of this thesis. It is most likely though, that as with the case of a

SAM “hunting” UAV, a more general, survivable UAV designed to go after TBMs could also carry out this second “unknowns” type mission.

C. LETHAL UAV DESIGNS THAT ARE MOST FEASIBLE

Given the premise stated above – that primary attention should be focused on designing UAVs to hunt TBMs, the next step is to look at those designs that are most feasible, using currently available UAV, sensor and payload technology. As already stated in Chapter III, the Tier II+ is by far the most capable UAV platform being designed. However, there would certainly be missions where the probability of attrition is high enough to warrant using a less expensive UAV, and given its list of capabilities and low cost, the Predator would certainly make a fine alternative for use on such missions. Thus, it is envisioned that a successful Lethal UAV program, if initiated at this time, would include both Tier II+ and Predator UAVs. (The Tier III- could also be used as described in Section A above, but would be a reconnaissance and targeting asset, not a Lethal UAV.)

As far as weapons are concerned, because problems with using kinetic kill vehicles in a boost phase intercept have not been solved, it would appear that the U.S. would have to be content with the more conventional method of locating TBMs (preferably before launch) while still on their transporter-erector-launchers (TELs) and then destroying the missiles and/or TELs with air-to-ground weapons.

Unfortunately, this strategy, known in Warfare Analysis circles as TBM counterforce, might allow an enemy successful launch of one or more missiles prior to TEL destruction. However at least one study (conducted at the Naval Postgraduate School) has effectively shown that improved attacks on TELs yields a resultant reduction in damage caused by enemy TBMs that is exponentially greater than that achieved by improving attacks against TBMs in their terminal phase [Ref. 36]. Thus, it would seem that money being spent to upgrade terminal attack weapons, such as the Patriot missile system, might be better spent on building UAVs designed to attack missile launchers and

in designing sensors that would better equip these same UAVs to find TBMs and TELs that are hidden or camouflaged.

As far as air-to-ground weapons are concerned, because of its smaller payload, choices for the Predator are limited. Currently the only MOTS weapons that are feasible for carrying on the Predator are the TOW and Hellfire anti-tank missiles, both of which have limited range. Additionally, a Predator carrying two Hellfire missiles along with its standard loadout of sensors would have to give up at least 250 pounds (101 pounds per missile and about 50 pounds of launcher and wiring weight) of fuel with a resultant endurance reduction of about 20 hours. Thus the UAV would have a stand-off firing range of 4.3 nm., but would be reduced to a total endurance of about 25 to 30 hours and would have to fly missions with either shorter on-station times or a shorter operational radius. While a similar loadout using TOW missiles would reduce the UAV's endurance by only about 10 hours, the system would then have a stand-off range of only 2.2 nm.

However, in either case, the Lethal UAV would have sufficient stand-off range to protect it from small arms fire and might not be detected at all, barring the presence of radar nearby. Additionally, with the stand-off range afforded by the Hellfire missile, the UAV could remain outside the range of any man-portable IR missiles. While issues such as weapons mounting and system integration would have to be handled, because both the TOW and Hellfire are already part of military inventory, their inclusion on a Predator-based Lethal UAV would take at most a few months. This would quickly give the U.S. military a limited Lethal UAV capability that could be used to hunt TBMs in areas not guarded by SAMs, a not all-too-uncommon scenario for smaller countries with limited air defense resources. Additionally, fielding of the Army's TACAWS missile some time around the year 2000, would allow the Predator a lethal stand-off range exceeding that of the Hellfire with only about two-thirds the current weight requirement.

For the Tier II+ UAV, because of larger payload capacity, the choices for weapons configuration are much broader. While the Tier II+ could easily carry smaller weapons like the TOW and Hellfire, because of their limited range and warhead size it is more

likely that the Tier II+ would be used to carry 250 or 500 pound standard bombs with either laser or GPS guidance conversion kits attached. Of these, the GBU-12, a 500 pound LGB, is already a part of military weapons stock. However, other variations are either in development or could be built-up for use by 1997 when the Tier II+ is expected to be ready for operational use. Of these weapons, a 250 pound LGB would be optimum in that it would offer the best combination of precision guidance, relative weight savings and explosive damage needed for destroying TBMs. However, stand-off range would be limited to about 6 nm. when using any type of bomb, even though dropped from 65,000 feet.

Missiles like the AGM-65E Maverick or a Mk-80 series bomb converted to a missile would offer an increase in range, but perhaps the most efficient weapon for the Tier II+ would be the Air Forces' LOCATM, which is still under development. This 300 pound missile will most likely be ready by the year 2000 and would allow the Tier II+ a 22 nm. stand-off range. When combined with the Tier II+ UAV's survivability features, this stand-off range might allow the UAV to attack a TBM site that is protected by medium or even long range SAMs. Additionally, with four of these missiles attached, the UAV would give up only about 10 per cent of its fuel capacity, and thus retain a maximum endurance of nearly 38 hours.

Of course, a long range air-to-surface missile designed specifically for the Tier II+ would be even better, but this could not likely be fielded before the year 2005 and would probably weigh closer to 1000 pounds, limiting the UAV to a payload of only two such weapons. Thus, by the year 1997 the U.S. could conceivably have a high altitude Lethal UAV with a medium range standoff capability that is subject to improvement as new weapons technologies matured.

VI. CONCLUSION

In summary, this thesis has shown that given the current technology available in UAVs, sensors and weapons, that the design of a UAV capable of detecting and destroying TBMs and other mobile weapons platforms is both viable and desirable. In fact, two long endurance UAVs already under DoD contract exhibit many of the features needed in a Lethal UAV and with only minor modifications could provide the U.S. military with a two tiered solution to the problem of TBM defense. The Predator UAV could serve almost immediately as an interim Lethal UAV, offering the ability to remain over enemy territory for up to 30 hours, detecting and destroying TBMs or other mobile weapons platforms. A Tier II+ Lethal UAV could be available as early as 1997 and would serve as a more capable platform, staying on station over more heavily defended areas for up to 36 hours and using more powerful sensors and weapons to search out and destroy enemy targets. Used together, the two systems, with their unique capabilities and relatively low cost, would provide an inexpensive solution to the problem of locating and destroying mobile enemy weapon systems. While these two systems are by no means perfect, they currently represent the most cost effective, technologically feasible method of getting the job done and it is expected that with further advances in sensor and weapons technology that Lethal UAVs would become even more capable.

Additionally, it is recommended that work done at the Naval Postgraduate School in the area of Lethal UAV simulation be continued, as it can play an important role in the validation of possible real world Lethal UAV systems. In fact, given the current economic climate, a valid proof of concept, such as is available with accurate digital simulation, may just mean the difference between Lethal UAV concept and reality.

LIST OF REFERENCES

1. Kaltenberger, B. R., *Unmanned Air Vehicle/Remotely Piloted Vehicle Analysis for Lethal UAV/RPV*, Master's Thesis, Naval Postgraduate School, Monterey, CA, September 1993.
2. Fulghum, D. A., "Scud-Killing UAVs Now Science Tools," *Aviation Week & Space Technology*, p. 27, October 31, 1994.
3. Munson, K., *World Unmanned Aircraft*, Jane's Publishing, 1988.
4. Wagner, W. and Sloan, W. P., *Fireflies and Other UAVs*, Aerofax, 1992.
5. Siuru, B., *Planes Without Pilots*, TAB/AERO, 1991.
6. Colemon, R., "New Horizons for Unmanned Reconnaissance Aircraft," *Naval Aviation News*, pp. 15-17, March-April 1995.
7. Lovece, J., "Washington Perspective," *Unmanned Systems*, pp. 46-52, Spring 1995.
8. Verhey, C. T., "Hunter Joint Tactical UAV: Navigating from Demonstration to Initial Fielding of the Only Fully Supportable, Mil-spec UAV System in the U.S.," *Unmanned Systems*, pp. 20-23, Spring 1995.
9. Morrocco, J. D., "Decision Time Approaches for Dormant Manuever UAV," *Aviation Week & Space Technology*, pp. 56-57, July 10, 1995.
10. Defense Airborne Reconnaissance Office, *Unmanned Aerial Vehicles Program Plan*, Department of Defense, April 1994.
11. Green, G., "Washington Perspective," *Unmanned Systems*, pp. 40-43, Summer 1994.
12. Harbison, I., *Unmanned Vehicles Handbook: 1993-1994*, The Shephard Press, 1993.
13. Fulghum, D. A., "DARO Pushes Endurance UAVs," *Aviation Week & Space Technology*, p. 23, April 11, 1994.
14. Lovece, J., "U.S. Military Services Finally Embrace UAVs Just As Procurement Funds Dwindle," *Armed Forces Journal International*, pp. 21-23, July 1993.
15. Brown, S. F., "The Eternal Airplane," *Popular Science*, p. 72, April 1994.

16. Fulghum, D. A. and Morrocco, J. D., "U.S. Military to Boost Tactical Recon in '95," *Aviation Week & Space Technology*, pp. 22-23, January 9, 1995.
17. Evers, S., "GNAT-750 May Raise Profile of UAVs," *Aviation Week & Space Technology*, pp. 54-55, February 7, 1994.
18. Fulghum, D. A., "Tier 2 Endurance UAV Nears First Flight," *Aviation Week & Space Technology*, pp. 20-21, May 16, 1994.
19. Snively, R.C., "Predator: An Advanced Concept Technology Demonstration," *Unmanned Systems*, pp. 25-29, Spring 1995.
20. Fulghum, D. A., "Predator to Make Debut Over War-Torn Bosnia," *Aviation Week & Space Technology*, pp. 47-48, July 10, 1995.
21. Fulghum, D. A. and Morrocco, J. D., "U.S. Readies Predator for Missions in Bosnia," *Aviation Week & Space Technology*, June 5, 1995.
22. Dornheim, M. A., "Tier 3 Minus to Test Value of Stealth," *Aviation Week & Space Technology*, pp. 41-42, June 12, 1995.
23. Scott W. B., "Tier 2-Plus UAV Bidders Enjoy New Flexibility," *Aviation Week & Space Technology*, pp. 22-23, May 16, 1994.
24. Fulghum, D. A., "International Market Eyes Endurance UAVs," *Aviation Week & Space Technology*, pp. 40-43, July 10, 1995.
25. Fulghum, D. A., "Tier 2+ Tricks Enemy Missiles," *Aviation Week & Space Technology*, p. 49, July 10, 1995.
26. Dornheim, M. A., "New Sensors Show Two Paths to Reconnaissance," *Aviation Week & Space Technology*, pp. 42-46, July 10, 1995.
27. Mann P., "Washington Outlook," *Aviation Week & Space Technology*, pp. 42-46, July 10, 1995.
28. Fulghum, D. A., "Stealthy UAV is a Flying Wing," *Aviation Week & Space Technology*, p. 21, July 11, 1994.
29. Fulghum, D. A., "Secret Flying Wing Slated for Rollout," *Aviation Week & Space Technology*, pp. 27-28, September 19, 1994.

30. Dornheim, M. A., "Mission of Tier 3- Reflected in Design," *Aviation Week & Space Technology*, pp. 52-55, June 19, 1995.
31. Fulghum, D. A., "Tier 2 UAV Aborts First Test Flight," *Aviation Week & Space Technology*, p. 22, July 11, 1994.
32. Mulford, L., "Skyball: The Eyes of the Predator," *Unmanned Systems*, pp. 30-31, Fall 1994.
33. Munson, K., "Payloads Pay Their Own Way," *Defense Helicopter*, pp. 34-37, February-March 1993.
34. Lennox, D., *Jane's Air Launched Weapons*, Jane's Information Group, 1994.
35. Green, J. K., Hope, S., Kammann, R., Knowles, M., Rondeau, A. and Winfrey, S., *Digital Simulation and Design of a Lethal UAV*, AA4276 Design Paper, Naval Postgraduate School, Monterey, CA, June 1995.
36. Marshall, K. T., *The Roles Of Counterforce and Active Defense in Countering Theater Ballistic Missiles*, Technical Report NPS-OR-94-012, Naval Postgraduate School, Monterey, CA, September 1994.

INITIAL DISTRIBUTION LIST

1. Defense Technical Information Center 2
 Cameron Station
 Alexandria, Virginia 22304-6415
2. Library, Code 52 2
 Naval Postgraduate School
 Monterey, California 93943-5101
3. Chairman 2
 Department of Aeronautics and Astronautics
 Naval Postgraduate School
 Monterey, California 93943-5002
4. Dr. Isaac I. Kaminer, Code AA/KA 2
 Department of Aeronautics and Astronautics
 Naval Postgraduate School
 Monterey, California 93943-5002
5. CAPT. (Ret.) George W. Conner, Code OR/CO 10
 Naval Postgraduate School
 Department of Operations Research
 Monterey, California 93943-5002
6. Professor Phillip Pace, Code EE/PC 1
 Naval Postgraduate School
 Department of Computer and Electrical Engineering
 Monterey, California 93943-5121
7. Mr. Jay Willmott 1
 BAI Aerosystems, Inc.
 9040 Glebe Park Drive
 P.O. Box 1600
 Easton, Maryland 21601
8. LT John K. Green 2
 8758 875th Ave. W.
 Oak Harbor, Washington 98277