



**Calhoun: The NPS Institutional Archive**

---

Reports and Technical Reports

All Technical Reports Collection

---

2008-04-01

# Volume II: Acquisition Research: Creating Synergy for Informed Change

NPS Acquisition Research Program

---

<http://hdl.handle.net/10945/33273>



Calhoun is a project of the Dudley Knox Library at NPS, furthering the precepts and goals of open government and government transparency. All information contained herein has been approved for release by the NPS Public Affairs Officer.

**Dudley Knox Library / Naval Postgraduate School  
411 Dyer Road / 1 University Circle  
Monterey, California USA 93943**

<http://www.nps.edu/library>

NPS-AM-08-023



# PROCEEDINGS

---

OF THE  
FIFTH ANNUAL ACQUISITION  
RESEARCH SYMPOSIUM  
THURSDAY SESSIONS  
VOLUME II

**Acquisition Research:  
Creating Synergy for Informed Change**

**May 14-15, 2008**

**Published: 23 April 2008**

Approved for public release, distribution is unlimited.

Prepared for: Naval Postgraduate School, Monterey, California 93943



ACQUISITION RESEARCH PROGRAM  
GRADUATE SCHOOL OF BUSINESS & PUBLIC POLICY  
NAVAL POSTGRADUATE SCHOOL

The research presented at the symposium was supported by the Acquisition Chair of the Graduate School of Business & Public Policy at the Naval Postgraduate School.

**To request Defense Acquisition Research or to become a research sponsor, please contact:**

NPS Acquisition Research Program  
Attn: James B. Greene, RADM, USN, (Ret.)  
Acquisition Chair  
Graduate School of Business and Public Policy  
Naval Postgraduate School  
555 Dyer Road, Room 332  
Monterey, CA 93943-5103  
Tel: (831) 656-2092  
Fax: (831) 656-2253  
E-mail: [jbgreene@nps.edu](mailto:jbgreene@nps.edu)

Copies of the Acquisition Sponsored Research Reports may be printed from our website [www.acquisitionresearch.org](http://www.acquisitionresearch.org)

Conference Website:  
[www.researchsymposium.org](http://www.researchsymposium.org)



ACQUISITION RESEARCH PROGRAM  
GRADUATE SCHOOL OF BUSINESS & PUBLIC POLICY  
NAVAL POSTGRADUATE SCHOOL

## Preface and Acknowledgements

One hundred years ago, William H. Allen—of the then-newly founded Bureau of Municipal Research—issued a call in the *Journal of Accountancy* for “1,000 accountants for municipal research.” Reflecting the Progressive Era’s focus on domestic reform after the closing of the American frontier, Allen wrote:

Only a pessimist will believe that the day is past for the pioneer. It is true that America has been discovered and that the law of diminishing returns long since began to operate in the gold fields of California, the wheat fields of the Northwest and the oil wells of Pennsylvania. It is also true that there is less opportunity today than ever before for adventure of the story book type. But to young men [sic] capable of thrilling with excitement when confronted with new problems to solve and new ideas to work out, I wish seriously to recommend a substitute for the North Pole—the unexploited field of municipal accounting and municipal business.<sup>1</sup>

Allen’s call followed the Bureau’s early and remarkable successes, both in exposing waste and corruption in New York City’s government and in devising and installing managerial systems for increased efficiency and transparency:

[T]he mayor, comptroller, commissioner of street cleaning, president of Bellevue and allied hospitals, commissioner of parks and the commissioners of accounts have requested cooperation, and used departmental facilities and men [sic] for research and reorganization. We believe that similar cooperation will be obtained wherever private bodies or especially trained accountants approach the problem of municipal business with the sole motive of advancing the interests of the general public, and not with a desire to do sharpshooting, to turn up a scandal or to turn out the rascals.<sup>2</sup>

History has not recorded the extent to which Allen’s call for 1,000 accountants was answered. History has recorded, however, the very clear and significant contributions of his Bureau’s work—particularly its research agenda—to the formation of the field of American Public Administration.<sup>3</sup> Thus, while Allen certainly perceived the potential contributions of administrative research, it’s highly doubtful he could have imagined the development and maturation over the next century of this entirely new field of study in the US. Public Administration today includes hundreds of graduate degree programs, dozens of academic journals and conferences, and thousands of scholars. The objects of its study have expanded from municipal administration to include federal, state, international, and, more recently, not-for-profit administration.

---

<sup>1</sup> Allen, W.H. (1908, July). Wanted—One thousand efficient accountants for municipal research. *Journal of Accountancy*, 6, 187.

<sup>2</sup> Allen, 1908, pp. 192-193.

<sup>3</sup> Waldo, D. (1984). *The administrative state* (2<sup>nd</sup> ed.). New York: Holmes & Meier, p. 31.



Today, we issue a call for “1,000 scholars for defense acquisition research.” As Allen believed in the possibilities for municipal research, we also believe in the possibilities for melioration of acquisition’s seemingly intractable problems through systematic study. While Allen saw the skills of accountants as sufficient for the tasks he had in mind, we instead call for a truly interdisciplinary mix of scholars suitable for engaging the diverse facets of acquisition’s many technical, managerial, and political issues.

Obviously, such an ambitious call cannot be answered by a single or even a dozen institutions. Accordingly, the NPS Acquisition Research Program has among its principal objectives the cultivation of an interdisciplinary community of acquisition scholars from many institutions around the world. This Symposium is merely a single step toward achieving that objective. Other recent steps include new research partnerships that NPS has forged with several other universities and the new *International Journal of Defense Acquisition Management* (<http://www.acquisitionjournal.org>), a scholarly journal jointly published and supported by the Acquisition Research Program and Cranfield University at the Defence College of Management of Technology.

From our limited perspective, such steps may seem woefully inadequate for the task of achieving meaningful and lasting acquisition reform. If so, we may do well to look forward into the next century and imagine our intellectual descendents who will study in a fully mature field of defense acquisition management and who will commend us for our efforts.

We gratefully acknowledge the ongoing support and leadership of our sponsors, whose foresight and vision have assured the continuing success of the Acquisition Research Program:

- Under Secretary of Defense (Acquisition, Technology and Logistics)
- Program Executive Officer (Ships)
- Program Executive Officer (Integrated Warfare Systems)
- Program Executive Officer (Littoral and Mine Warfare)
- Commander, Naval Sea Systems Command
- Deputy Assistant Secretary of the Navy (Acquisition and Logistics Management)
- Office of Naval Air Systems Command PMA-290
- Office of the Assistant Secretary of the Army for Acquisition, Logistics and Technology
- Director, Strategic Systems Program
- Project Manager Modular Brigade Enhancements
- Deputy Assistant Secretary Air Force (Management Policy & Program Integration)
- Dean of Research, Naval Postgraduate School

We also thank the Naval Postgraduate School Foundation and acknowledge its generous contributions in support of this Symposium.

James B. Greene, Jr.  
Rear Admiral, US Navy (Ret.)

Keith F. Snider, PhD  
Associate Professor

Karey L. Shaffer, MBA  
Program Manager, Acquisition Research Program



## The NPS A Team

**Rear Admiral James B. Greene, Jr. USN (Ret.)**—Acquisition Chair, Naval Postgraduate School. RADM Greene develops, implements and oversees the Acquisition Research Program in the Graduate School of Business and Public Policy. He interfaces with DoD, industry and government leaders in acquisition, coordinates graduate student projects and conducts guest lectures and seminars. Before serving at NPS, RADM Greene was an independent consultant focusing on Defense Industry business development strategy and execution (for both the public and private sectors), minimizing lifecycle costs through technology applications, alternative financing arrangements for capital-asset procurement, and “red-teaming” corporate proposals for major government procurements.

RADM Greene served as the Assistant Deputy Chief of Naval Operations (Logistics) in the Pentagon from 1991-1995. As Assistant Deputy, he provided oversight, direction and budget development for worldwide US Navy logistics operations. He facilitated depot maintenance, supply chain management, base/station management, environmental programs and logistic advice, and support to the Chief of Naval Operations. Some of his focuses during this time were leading Navy-wide efforts to digitize all technical data (and, therefore, reduce cycle-time) and to develop and implement strategy for procurement of eleven Sealift ships for the rapid deployment forces. He also served as the Senior Military Assistant to the Under Secretary of Defense (Acquisition) from 1987-1990; as such, he advised and counseled the Under Secretary in directing the DoD procurement process.

From 1984-1987, RADM Greene was the Project Manager for the AEGIS project. This was the DoD’s largest acquisition project, with an annual budget in excess of \$5 billion/year. The project provided oversight and management of research, development, design, production, fleet introduction and full lifecycle support of the entire fleet of AEGIS cruisers, destroyers, and weapons systems through more than 2500 industry contracts. From 1980-1984, RADM Greene served as Director, Committee Liaison, Office of Legislative Affairs followed by a tour as the Executive Assistant, to the Assistant Secretary of the Navy (Shipbuilding and Logistics). From 1964-1980, RADM Greene served as a Surface Warfare Officer in various duties, culminating in Command-at-Sea. His assignments included numerous wartime deployments to Vietnam, as well as the Indian Ocean and the Persian Gulf.

RADM Greene received a BS in Electrical Engineering from Brown University in 1964; he earned an MS in Electrical Engineering and an MS in Business Administration from the Naval Postgraduate School in 1973.

**Keith F. Snider**—Associate Professor of Public Administration and Management in the Graduate School of Business & Public Policy at the Naval Postgraduate School in Monterey, California, where he teaches courses related to defense acquisition management. He also serves as Principal Investigator for the NPS Acquisition Research Program and as Academic Associate for resident NPS acquisition curricula.

Professor Snider has a PhD in Public Administration and Public Affairs from Virginia Polytechnic Institute and State University, a Master of Science degree in Operations Research from the Naval Postgraduate School, and a Bachelor of Science degree from the United States Military Academy at West Point. He served as a field artillery officer in the US Army for twenty years, retiring at the rank of Lieutenant Colonel. He is a former member of



the Army Acquisition Corps and a graduate of the Program Manager's Course at the Defense Systems Management College.

Professor Snider's recent publications appear in *American Review of Public Administration*, *Administration and Society*, *Administrative Theory & Praxis*, *Journal of Public Procurement*, *Acquisition Review Quarterly*, and *Project Management Journal*.

**Karey L. Shaffer**—Program Manager for General Dynamics Information Technology in support of the Acquisition Research Program at the Graduate School of Business and Public Policy, Naval Postgraduate School. As PM, Shaffer is responsible for operations and publications in conjunction with the Acquisition Chair and the Principal Investigator. She has also catalyzed, organized and managed the Acquisition Research Symposiums hosted by NPS.

Shaffer has also served as the Project Manager for Imagicast, Inc., and as the Operations Manager for the Montana World Trade Center. At Imagicast, she was asked to take over the project management of four failing pilots for Levi Strauss in the San Francisco office. Within four months, the pilots were released; the project lifecycle was shortened; and the production process was refined. In this latter capacity at the MWTC, Shaffer developed operating procedures, policies and processes in compliance with state and federal grant law. Concurrently, she managed \$1.25 million in federal appropriations, developed budgeting systems and secured a \$400,000 federal technology grant. As the Operations Manager, she also designed MWTC's Conference site, managed various marketing conferences, and taught student practicum programs and seminars.

Shaffer holds an MBA from San Francisco State University and earned her BA in Business Administration (focus on International Business, Marketing and Management) from the University of Montana.

**A special thanks** to our editors Jeri Larsen, Breanne Grover and Jessica Moon for all that they have done to make this publication a success, to David Wood, Tera Yoder and Ian White for production and graphic support and to the staff at the Graduate School of Business & Public Policy for their administrative support. Our program success is directly related to the combined efforts of many.







# ACQUISITION RESEARCH: CREATING SYNERGY FOR INFORMED CHANGE

6<sup>th</sup> Annual Acquisition Research Symposium

May 13 - 14, 2009

Monterey, California

---

## Announcement and Call for Proposals

The Graduate School of Business & Public Policy at the Naval Postgraduate School announces the 6<sup>th</sup> **Annual Acquisition Research Symposium** to be held **May 13-14, 2009 in Monterey, California**.

This symposium serves as a forum for the presentation of acquisition research and the exchange of ideas among scholars and practitioners of public-sector acquisition. We seek a diverse audience of influential attendees from academe, government, and industry who are well placed to shape and promote future research in acquisition.

The Symposium Program Committee solicits proposals for panels and/or papers from academicians, practitioners, students and others with interests in the study of acquisition. The following list of topics is provided to indicate the range of potential research areas of interest for this symposium: **acquisition and procurement policy, supply chain management, public budgeting and finance, cost management, project management, logistics management, engineering management, outsourcing, performance measurement, and organization studies**.

Proposals must be submitted by **November 7, 2008**. The Program Committee will make notifications of accepted proposals by **December 5, 2008**. Final papers must be submitted by **April 3, 2009** to be included in the Symposium Proceedings.

Proposals for papers should include an abstract along with identification, affiliation, and contact information for the author(s). Proposals for papers plan for a 20 minute presentation. Proposals for panels (plan for 90 minute duration) should include the same information as above as well as a description of the panel subject and format, along with participants' names, qualifications and the specific contributions each participant will make to the panel.

**Submit paper and panel proposals** to [www.researchsymposium.org](http://www.researchsymposium.org) .





THIS PAGE INTENTIONALLY LEFT BLANK



NPS-AM-08-023



# PROCEEDINGS

OF THE

---

## FIFTH ANNUAL ACQUISITION RESEARCH SYMPOSIUM THURSDAY SESSIONS VOLUME II

### **Acquisition Research: Creating Synergy for Informed Change**

**May 14-15, 2008**

**Published: 23 April 2008**

Approved for public release, distribution unlimited.

Prepared for: Naval Postgraduate School, Monterey, California 93943

Disclaimer: The views represented in this report are those of the authors and do not reflect the official policy position of the Navy, the Department of Defense, or the Federal Government.



THIS PAGE INTENTIONALLY LEFT BLANK



# Table of Contents

Thursday Sessions, May 15, 2008

<b>Keynote Speaker</b> .....	<b>247</b>
<b>Panel 11 - Plenary Panel – Academic Research on Contracting</b> .....	<b>249</b>
<b>Panel 12 – Budgeting and the Acquisition Process</b> .....	<b>251</b>
Rethinking Acquisition Reform: Cost-growth Solutions May Aggravate More Important Problems .....	253
Panel 13 - Perspectives on COTS Implementation .....	267
Commercial-Off-the-Self (COTS): Impact to Reliability, Maintainability and Availability (RM&A) from an In Service Engineering Perspective.....	269
<b>Panel 14 - Issues in Cost Estimating for US Naval Shipbuilding</b> .....	<b>271</b>
Dynamic Cost Risk Assessment for Controlling the Cost of Naval Vessels .....	272
Using the Steel Vessel Material-cost Index to Mitigate Shipbuilder Risk .....	288
<b>Panel 15 - Key Issues in Defence Acquisition for the UK - Issues for other     Nations?</b> .....	<b>303</b>
Five Key Changes for the Management of UK Defence—An Agenda for Research? .....	305
<b>Panel 16 - Public Procurement: Environment, Limitations and Innovations</b> .....	<b>321</b>
<b>Panel 17 - Cost Estimating Initiatives in Defense Acquisition</b> .....	<b>323</b>
A Non-simulation Based Method for Inducing Pearson’s Correlation between Input Random Variables .....	325
Application of Transaction Cost Economics to Capabilities-based Acquisition: Exploring Single Service vs. Joint Service Programs and Single Systems vs. System-of-Systems .....	333
<b>Panel 18 - International Perspectives on Acquisition</b> .....	<b>355</b>
Summary of Echoes Across the Pond: Understanding EU-US Defense Industrial Relationships .....	356
Australian Naval Procurement Cycles: Lessons for Other Small Countries .....	361



Defense Acquisition Policy and Defense Industrial Base Reinforcement Strategy—Enhancing the International Competitiveness of the Korean National Defense Industry .....	388
<b>Panel 19 - Exploring the Boundaries of Outsourcing .....</b>	<b>405</b>
Contracting Out Government Procurement Functions: An Analysis.....	407
The Evolving Private Military Sector: A Survey .....	430
<b>Panel 20 - Issues in Supply Chain Management .....</b>	<b>453</b>
Managing the Services Supply Chain in the Department of Defense: An Empirical Study of Current Management Practices .....	455
Joint Robotics Program .....	467
<b>Additional Papers: .....</b>	<b>477</b>
Logical Decisions for Contracting: Integrated Decision Technology for Acquisition and Contracting.....	477
“Alternative Designs for a Joint Command, Control, Communications, Computers, and Intelligence (C4I) Capability Certification Management (JC3M) System” .....	478



## Keynote Speaker

---

<b>Thursday, May 15, 2008</b>	<b>Keynote Speaker</b>
<b>8:00 a.m. – 9:15 a.m.</b>	<b>Keynote Speaker</b>  <b>General Bruce Carlson</b> , United States Air Force, Commander, Air Force Materiel Command

General Bruce Carlson serves as Commander, Air Force Materiel Command, Wright-Patterson Air Force Base, OH. The command conducts research, development, test and evaluation, and provides acquisition management services and logistics support necessary to keep Air Force weapon systems ready for war.

Carlson was born in Hibbing, MN. He was commissioned in 1971, after completing the University of Minnesota's Air Force ROTC program as a distinguished graduate. He has held various assignments in flying units. Staff assignments have included positions at Tactical Air Command, Headquarters US Air Force, the offices of the Secretary of the Air Force and Secretary of Defense, and as the Director of Force Structure, Resources and Assessment with the Joint Staff. Additionally, he commanded the Air Force's stealth fighter wing, the 49th, at Holloman AFB, NM. Prior to assuming his current position, Carlson served as the Commander, 8th Air Force, Barksdale AFB, LA, and Joint Functional Component Commander for Space and Global Strike, US Strategic Command, Offutt AFB, NE.



Carlson is experienced in multiple aircraft weapons systems, is a command pilot with more than 3,000 flying hours, and has combat experience in the OV-10.

---



THIS PAGE INTENTIONALLY LEFT BLANK





## Panel 11 - Plenary Panel – Academic Research on Contracting

---

<b>Thursday, May 15, 2008</b>	<b>Panel 11 – Plenary Panel – Academic Research on Contracting</b>
<b>9:30 a.m. – 11:00.m.</b>	<b>Chair:</b>  <b>Dr. Steve Kelman</b> , Professor of Public Management, John F. Kennedy School of Government, Harvard University  <b>Discussants:</b>  <b>Dr. Matthew Potoski</b> , Associate Professor, Department of Political Science, Iowa State University  <b>Dr. G. Frederick Thompson</b> , Professor of Public Management and Policy, Atkinson Graduate School of Management, Willamette University  <b>Dr. Andrew B. Whitford</b> , Associate Professor of Public Administration and Policy, School of Public & International Affairs, The University of Georgia

---

**Chair: Dr. Steve Kelman** is the Weatherhead Professor of Public Management at Harvard University's John F. Kennedy School of Government. A *summa cum laude* graduate of Harvard College, with a PhD in Government from Harvard University, he is the author of many books and articles on the policymaking process and on improving the management of government organizations. His most recently published books are a study on how to improve the government computer procurement process, entitled *Procurement and Public Management: The Fear of Discretion and the Quality of Government Performance* (AEI Press, 1990), and *Making Public Policy: A Hopeful View of American Government* (Basic Books, 1987). In 1996, he was elected a Fellow of the National Academy of Public Administration. In 2001, he received the Herbert Roback Memorial Award, the highest achievement award of the National Contract Management Association. In 2003, he was elected as a Director of The Procurement Roundtable.

From 1993 through 1997, Kelman served as Administrator of the Office of Federal Procurement Policy in the Office of Management and Budget. During his tenure as Administrator, he played a lead role in the Administration's "reinventing government" effort. He led Administration efforts in support of the *Federal Acquisition Streamlining Act* of 1994 and the *Federal Acquisition Reform Act* of 1995.

**Discussant: Dr. Matthew Potoski** is an Associate Professor at Iowa State University, where he teaches courses on politics, administration, and policy. In 1997 and 1998, he taught at the University of Kentucky's Martin School of Public Policy and Administration, first as a visiting fellow and later as visiting faculty. Potoski received his PhD from Indiana University in 1998, his undergraduate degree from Franklin and Marshall College in Lancaster, PA, and his Master's degree from the University of Vermont.

Potoski's research and teaching interests lie at the nexus of public policy, administration, and politics. His research examines how people address collective action problems and uncertainty inherent in developing, implementing and managing public policies. These problems in various guises undermine peoples' ability to solve complex problems and produce sound public policy. Such problems span levels of government and policy areas. He has published over two dozen articles in journals such as *American Journal of Political Science*, *Journal of Politics*, *Journal of Policy Analysis and*



*Management, Public Administration Review, Policy Studies Journal, State Politics and Policy Quarterly* and the *Journal of Public Administration Research and Theory*. Potoski is the recipient of the Indiana University Department of Political Science's 2000 Greenough Award for best dissertation completed in previous year, and the Iowa State University College of Liberal Arts and Sciences' 2004 Award for Early Achievement in Research/Artistic Creativity. He is the co-editor of *International Public Management Journal* and serves on the editorial board of *Journal of Public Administration Research and Theory*.

**Discussant: Dr. G. Frederick Thompson** is the Grace and Elmer Goudy Professor of public management and policy at Atkinson Graduate School of Management, Willamette University.

**Discussant: Dr. Andrew B. Whitford** is an Associate Professor of public administration and policy in the University of Georgia School of Public and International Affairs. He is a specialist in the areas of bureaucratic politics, organization theory and political economy. His interests in public policy include environmental, regulation and public health policy, and his research has been supported by the National Science Foundation (NSF), the Robert Wood Johnson Foundation and the Russell Sage Foundation. He has served on NSF advisory panels and is on the editorial board of *Political Research Quarterly*. His articles have been published in *Administrative Science Quarterly, American Journal of Political Science, British Journal of Political Science* and the *Journal of Public Administration Research*, and he is working on a book manuscript about presidential rhetoric in the war on drugs.

---



## Panel 12 – Budgeting and the Acquisition Process

---

<b>Thursday, May 15, 2008</b>	<b>Panel 12 - Budgeting and the Acquisition Process</b>
<b>11:15 a.m. – 12:45 a.m.</b>	<b>Chair:</b>  <b>The Honorable Douglas A. Brook</b> , Assistant Secretary of the Navy for Financial Management and Comptroller  <b>Discussant:</b>  <b>Ms. Wendy Kunc</b> , Director, Naval Center for Cost Analysis  <b>Rear Admiral Charles H. Goddard</b> , Program Executive Officer, Ships  <b>Paper:</b>  <b><i>Rethinking Acquisition Reform: Cost Growth Solutions May Aggravate the More Important Problem</i></b>  <b>Philip J. Candreva</b> , Senior Lecturer of Budgeting, Naval Postgraduate School

---

**Chair: The Honorable Douglas A. Brook** is Assistant Secretary of the Navy (Financial Management & Comptroller). Prior to reporting to the Pentagon, he was Professor of Public Policy and Director of the Center for Defense Management Reform at the Naval Postgraduate School in Monterey, California. From 2002 until 2005, Dr. Brook was Dean of the NPS Graduate School of Business and Public Policy.

Before joining NPS, Dr. Brook was Vice President—Government Affairs for The LTV Corporation. Prior to joining LTV, Brook served in two Presidentially appointed positions. In 1992, he was Acting Director of the US Office of Personnel Management (OPM), the central personnel management agency of the Federal government. From 1990 to 1992, Brook was Assistant Secretary of the Army for Financial Management.

Brook began his career as Director of Public Finance of the National Association of Manufacturers in New York. Subsequently, he joined the Libbey-Owens-Ford Company and served as Vice President and head of the company's Washington, DC, office.

In 1982, he founded Brook Associates, Inc., a public affairs consulting business serving corporate and trade association clients, which he managed until assuming duties at the Pentagon. He also served two elected terms on the Town Council of Vienna, VA.

Brook grew up in East Detroit, MI. He attended the University of Michigan, graduating with a Bachelor of Arts degree in Political Science in 1965 and a Master of Public Administration degree in 1967. In 2001, he earned his PhD in Public Policy at George Mason University. He also completed the 1977 Executive Program at the University of Virginia's Colgate Darden Graduate School of Business Administration.



Brook served on active duty as a Navy Supply Corps officer and was a member of the Naval Reserve for 30 years. He retired with the rank of Captain.

**Discussant: Ms. Wendy P. Kunc** was selected to the Senior Executive Service in March 2005 and currently serves as Director, Naval Center for Cost Analysis (NCCA) and leader of the Department of the Navy Cost Analysis and Management Sciences community. Prior to holding this position, Kunc headed NCCA's Cost Analysis Tools division and served as Naval VAMOSC program manager. Kunc held several positions within the Department of the Air Force, including Chief of the Cost Factors Branch within the Air Force Cost Analysis Agency. She also led the transition of Air Force VAMOSC to the more comprehensive Air Force Total Ownership Cost (AFTOC) system.

Kunc holds a Bachelor's degree in Mathematics from the University of Missouri and Master of Science degrees in Computer Information Systems from St. Mary's University, San Antonio, and National Resource Strategy from the National Defense University. She completed the National Defense University's CIO certification program in 2005. Kunc is a Certified Defense Financial Manager, is Level III certified in the Defense Acquisition Workforce, and is a member of the Acquisition Corps.

**Discussant: Rear Admiral Charles Goddard** graduated from the US Naval Academy in 1978 with a Bachelor of Science degree in Naval Architecture. He also holds a Master of Science degree in Naval Architecture and Ocean Engineer from the Massachusetts Institute of Technology (MIT).

Goddard achieved Surface Warfare Qualification in USS *Robert E. Perry* (FF 1073), where he served as Anti-Submarine Warfare Officer and Auxiliaries and Electrical Officer.

He became an Engineering Duty Officer in 1981. His engineering duty officer tours include: Pearl Harbor Naval Shipyard as Ship Superintendent, 1981-1982; Long Beach Naval Shipyard as Ship Superintendent and Type Desk Officer, 1986-1989; David Taylor Research Center as System Engineer for the Advanced Surface Machinery Program, 1989-1992; Naval Sea Systems Command as Surface Stealth Project Officer, 1992-1995; Supervisor of Shipbuilding San Diego as New Construction Officer, 1995-1998; Naval Sea Systems Command as Director of Ship Research and Development, 1998; and as Strategic Sealift Deputy Program Manager (PMS 385), 1999. Goddard served as a Chief of Naval Operations Fellow on the Strategic Studies Group from 1999-2000, Executive Assistant to Commander, Naval Sea Systems Command from 2000-2001; DD(X) Program Manager from 2001-2005; and as Vice Chief, Naval Sea System Command from 2005 to 2007. He assumed his present duties in February 2007. He is a member of the Acquisition Professional Community and a graduate of the Program Manager's Course at the Defense Systems Management College.

Goddard's personal decorations include the Legion of Merit (two awards), Navy Meritorious Service Medal (two awards) and Navy Commendation Medal (two awards). He is the author of several articles on the topic of ship design and construction, and recipient of the American society of Naval Engineers Gold Medal Award for his contributions to ship design and engineering.



# Rethinking Acquisition Reform: Cost-growth Solutions May Aggravate More Important Problems

---

**Presenter: Phil Candreva, M.S.**, Senior Lecturer of Budgeting, Graduate School of Business and Public Policy, NPS. Candreva's research investigates how government organizations use financial information in such areas as resource allocation decision-making, accounting, performance measurement, and management reform. Most contemporary public sector management reform efforts are either explicitly tied to financial decisions (e.g., performance-based budgeting) or are implicitly tied through other management efforts (e.g., efficiency programs). Since budgets are the battlefield on which public policy disputes are waged, public managers must become proficient at showing how effectively and efficiently those resources are being used in order to preserve or expand their resource base. Such efforts are a critical dimension of contemporary management reform.

Philip J. Candreva  
Senior Lecturer of Budgeting  
Senior Associate, Center for Defense Management Reform  
Naval Postgraduate School  
555 Dyer Road  
Monterey, CA 93943  
Phone: 831-656-2884  
E-mail: [pjandre@nps.edu](mailto:pjandre@nps.edu)

---

## Abstract

There is increasing dissatisfaction with cost growth in major defense acquisition programs. Cost growth crowds out other investments, stresses budgets or causes schedule slips, all of which result in a military force that is less capable than previously expected. Several recent studies have recommended two categories of reforms: capital budgeting reforms seek stability in acquisition accounts, and rational cost model reforms seek to reduce the percentage increase of final cost over budget estimates. In both categories, undesirable secondary effects may be worse than the desirable primary effects; specifically, reforms that reduce cost growth may do so by driving total costs higher. This study examines these reforms and discusses their secondary effects. The paper concludes that the current practice of generating low estimates, coupled with dissatisfaction with cost growth may best serve to limit total cost.

## Introduction

Cost growth in defense acquisition programs is a problem that captures the attention of the general public, the media, Congress, defense reformers, and the acquisition community. Cost growth is said to reduce the affordability of the long-term defense program, resulting in top-line budget increases, reduced or late programs, or a combination of the two. Despite over a decade of growing defense budgets (even when one excludes the burden and cost of GWOT borne outside the regular budget process), service chiefs feel increasingly constricted in their procurement accounts. From 2001 to 2007, the planned investment in new programs doubled—from a portfolio valued at approximately \$750 billion to almost \$1.5 trillion (GAO, 2007, March, p. 3). Cost growth is a persistent and perhaps intractable problem:



- *Historical performance has not been good.* The GAO has included defense acquisition management among its High Risk programs since the list began in 1990, in part due to cost management. “Weapons systems routinely take much longer to field, cost more to buy, and require more support than provided for in investment plans” (GAO, 2007, January, p. 61). The GAO’s review of 27 weapons systems showed total cost growth of 19%, RDT&E growth of over 33% and schedule slippages of 23% (GAO 2007, March, p. 9). Looking back over the last three decades, RAND has shown that cost growth has averaged about 46%—that is, programs actually cost 46% more than estimated at Milestone B—and that cost performance has not improved despite numerous and continuous acquisition reform efforts (Younossi et al., 2007).
- *The problem is expected to continue into the future.* Using historical performance as a predictor of future needs, the CBO projects that the investment accounts in the FYDP are underfunded by about 28% (CBO, 2007, p. 14).
- *The phenomena are well-understood and documented.* The *Defense Acquisition Performance Assessment (DAPA)* report stated:

Over many years, 128 studies have been done to address perceived problems with the system and to prevent waste, fraud and abuse. Historically, we observed that cost and schedule instability have been a problem in all system acquisitions since the Civil War. We see some of the same issues as problems today that the Packard Commission saw 20 years ago. (Kadish et al., 2006, p. 2)

- *The critics and ideas are not all external to the Department.* The DoD’s own *Acquisition Transformation Report to Congress* lists seven implementation goals. Three include the term “cost-effective” in their title, and a fourth relates to governance and decision processes (Kreig, 2007, p. 6). It is not that DoD is turning a deaf ear; the intentions are all good.

There is no shortage of recommendations and plans to fix the problems of cost growth. Defense contractors, advisory bodies, and R&D centers have spent vast sums over the years chronicling such problems and offering solutions. Ninety (42%) of the 212 defense management reform initiatives in the period 1990-2006 dealt with acquisition and budgeting (Francis & Walther, 2006). The study of reform agendas and recommendations is an exercise in organizational evolution. Just as Darwin noted the beaks of the finches on the Galapagos Islands adapted gradually to their environments, recommendations to fix acquisition evolve slightly from report to report. This article takes a radically different tack—a leap on the reform recommendation evolutionary path, if you will. This article will argue that the cost-growth phenomenon may not even be a problem. It probably is less of a problem than the proffered solutions. In fact, if we assume DoD policies and procedures have evolved purposefully with competent managers in light of the available knowledge, then the current system may be the best available to ensure programs are delivered at the lowest cost. Attributes of some of the solutions to cost growth may actually drive total costs higher.

Those who study defense acquisition point to several problems associated with cost growth. One set of problems is related to the decision whether to invest. Underestimation “leads to poor investment choices” by starting more or larger programs than the department can afford (Melese, Franck, Angelis & Dillard, 2007, p. 358). If there is a business rule that a certain cost-benefit ratio threshold must be exceeded to make the initial investment, then an underestimate of cost may cause those making resource allocation decisions to err.





Similarly, in an analysis of alternatives, if the cost estimates are not uniformly inaccurate, resource-allocation decision-makers may make the wrong choice.

Another set of problems is related to the effects of growth after it occurs. Because the budget is a social contract, breaches of cost estimates can damage trust and relationships within government (Melese et al., 2007, p. 359). In some cases, they may breach legally imposed thresholds, the so-called Nunn-McCurdy breaches. When costs overrun, the remedy may involve stretching out schedules or reducing quantity, thereby reducing the new system's effect on the operating forces. The remedy may instead be a reallocation of funds away from a lower-priority program, thereby causing a different program's schedule or quantity to suffer. The remedy may also be a request for additional budget authority, imposing an opportunity cost for the nation as a whole.

The two most commonly proposed solutions to cost growth address the two sides of the problem that are most under governmental control: budget stability and cost-estimation accuracy. The former contends that increased funding stability would allow the program manager to shift attention to non-financial factors by insulating the program from the vagaries of politics and execution-year fiscal maneuvers. The GAO reported that over one-third of program managers said the biggest obstacle they faced was funding stability (GAO, 2005, p. 44). The latter contends that the problem originates with inaccurate cost estimates and that improved accuracy will contain cost growth. These reforms address the problem of unmet expectations by minimizing the *amount* of cost growth. In the process of doing so, they unfortunately fail to alleviate the *effects* of cost growth. In some cases, these reforms would introduce additional undesirable effects. This paper argues that instead of seeking to minimize relative cost growth, decision-makers should focus attention on minimizing total cost. Paradoxically, some of the very forces that hold total cost down are rooted in the dissatisfaction with cost growth.

## Capital Budgeting Reforms

Private industry—as well as many state and municipal governments—employs separate processes to budget for capital items and operating expenses. Most people in managing their household budgets do the same: we apply one form of decision logic when budgeting for the electric bill or groceries and a different logic when deciding to purchase a new car or major appliance. Within the DoD, procurement budgets are worked alongside operating and salary budgets, and both are appropriated on an annual line-item basis. Reformers have often questioned this practice. Most recently, the *2006 Quadrennial Defense Review* and the *Defense Acquisition Performance Assessment* recommended a form of capital budgeting.

Capital budgeting involves the analysis of costs and cash flows associated with an investment project that precedes and informs the decision to invest. At most levels of government (excepting, notably, the federal government), capital investment decisions are made in tandem with the decision of how to finance them—most being paid for with revenue measures such as a special tax assessment or with debt instruments such as bond issuances or loans. There is a deliberate link between the investment and its implications for current and long-term budgets, fiscal policy, asset management, and cash flows (Lee & Johnson, 1998).

The budgeting practice for capital investments at the federal level has a different flavor. Federal capital budgets do not necessarily need to be separate from operating





budgets in the absence of the balanced budget requirements common at the state and municipal level. The sovereign federal government may run deficits, raise revenues, print money, and borrow more readily than any other organization. Linking the capital purchase to a specific revenue stream is not necessary. Annual resource flows are often sufficient to fully fund the federal capital projects. Thus, they face the same annual review and trade-off decision-making as operating budget accounts.

Irrespective of the budgetary concern, federal capital projects are sometimes viewed as mechanisms for affecting macroeconomic conditions. Capital projects may be started, not because the ends of the project are the main objective, but because the job itself, the means to the end, is highly desirable. Programs during the Great Depression like the PWA, WPA and TVA were as much about creating jobs as they were about building bridges and dams. Urban renewal projects are more about sociological factors than buildings. Likewise, some capital investments in military systems are made in part to effect public objectives other than military capability. These short-term and complementary goals that are achieved through capital programs confound the analysis and argue against a separate capital budgeting strategy.

Private-sector capital budgeting practices are similar to those used in government and include lifecycle cost and benefit analyses. The costs include the obvious investment in the item, financing costs, and any incremental operating and support costs. Benefits include new revenue streams or lower operating and support costs. Investment decisions are based on one or more analytical techniques, such as payback period, net present value, or internal rate of return. These are benchmarked against a hurdle rate which represents the next best available use of the funds. Assuming the project will generate sufficient risk-adjusted return in a reasonable period of time, a capital budget is prepared. That budget is often distinct from, but affects, the organization's annual operating and support budget. The capital budget may be prepared outside the annual operating and support budget cycle, the timing more aligned with project schedules than accounting cycles. Funds to pay for the capital project also may be raised separately from the revenues raised by routine operations (but the service of debt, for example, would be incorporated into future operating budgets).

One significant problem with adapting capital budgeting for defense items is that there is no benefit that is easily defined in financial terms. Computation of a net present value or payback period is meaningless if the benefit and the cost cannot be expressed in consistent units.<sup>4</sup> There is no clear rate of return against which to compare to a hurdle rate. What can be done, however, is to perform a cost-effectiveness analysis for competing proposals that perform essentially the same task. Two alternative proposals for meeting the same need have presumably equal benefits and, therefore, can be compared based solely on a cost analysis. But comparison of capital budgets for items that generate disparate benefits is very problematic.

Acquisition reformers argue that best (or at least common) capital budgeting practices would provide much needed stability to the management of defense acquisition programs (Kadish et al., 2006; McCaffery & Jones, 2006). One form of the proposal is to separate the capital decision from the operating cost decision, to examine each capital decision when the program is ready, and to fund fully the development and acquisition costs

---

<sup>4</sup> Housel and Bell (2001) recognize this problem and suggest a methodology. Practical application of that methodology in the DoD is unlikely in the near term, if ever.



at that time. It is argued that such a practice will increase the likelihood of program success by addressing a significant risk factor. The FY 2007 *Defense Acquisition Transformation Report to Congress* clearly shows that the DoD accepts this argument (Kreig, 2007, p. 20). Such proposals, however, involve risk. Indeed, secondary costs may outweigh the primary benefit.

Isolating the capital investment decision necessarily removes it from the larger discussion of overall defense policy and resource allocation. The legislature prefers to debate and decide defense matters once in the annual authorization and appropriation process. Separating the capital items may cause the same issues to be debated twice or may mask interrelationships that should be considered as a whole. Just as the DoD considers the full portfolio of options during the programming phase of PPBE, the legislature needs to do the same. By separating the capital items from the rest of the program during budgeting, decision-makers could eliminate that possibility. Given the legislature's constitutional power to raise and support armies and provide and maintain a navy, such proposals seem politically infeasible.

Separation of the capital investment decision also has little practical benefit. Under existing full-funding policies, the entire amount to build an end-item is presumably budgeted and appropriated. If prepared properly, the budget request should have considered the lifecycle cost and independent cost analyses. If Congress appropriates the full funding in multi-year appropriations, based on the President's Budget, then the goals of a capital budgeting process have already been met. Curiously, the trend in the DoD, at least in the Navy, has been to expand the use of incremental budgeting over full funding—a practice clearly at odds with the stated recommendation to adopt corporate-style capital budgeting practices.

Another form of capital budgeting reform proposes to fence procurement dollars once appropriated. The problem this proposal attempts to remedy is that funds too easily move out of procurement programs to address contingent needs elsewhere in the budget. In some cases, one procurement program which is experiencing problems is assisted with funds taken from another procurement program. In other cases, contingencies may affect the operating accounts, and without sufficient budgetary slack to address the contingency, funds are transferred from procurement programs. The recommendation to fence funds, however, is a budgeting reform to what is actually a problem of execution discipline. If the services are concerned that funds are taken from one program to address issues in another, then they should simply stop doing that. Addressing the problem of execution discipline is a more appropriate remedy than creating a new budgetary approach. Easier said than done, critics will say. So if this reallocation is inevitable, what are the effects of such fences?

Fenced accounts serve to make the resources allocated to procurement more important than dollars allocated to operations; or, to put it another way, future readiness would become *de facto* more important than current readiness. It would be short-sighted to institutionalize such a decision, as it actually restricts flexibility to deal with unforeseen contingencies. If the procurement accounts cannot be a source to deal with the contingency, what *is* the source? Pay accounts? Operations elsewhere around the globe? Such fences also tend to restrict funds flowing in *both* directions. Many an acquisition program has benefited from reprogramming actions in which funds are taken from operating accounts; separate capital accounts may restrict these flows. The *Mine Resistant Ambush Protected (MRAP)* vehicle program received over a billion dollars in FY 2007 that way. The current



process is not perfect, but it may be better than inappropriately adopting a practice that is “best” in a different context.

To summarize, corporate and non-federal government models of capital budgeting do not adapt well to the federal government. While adoption of capital budgeting reforms would potentially stabilize the funding outlook for select acquisition programs, such actions inject rigidity into a process that demands flexibility in so many other areas. Fiscal law already imposes rigidity; the creation of special accounts for acquisition programs simply adds to that problem. Capital budgeting reforms are unlikely to be adopted if they limit broad analysis of the defense program and trade-offs within it. Nor will adoption be likely if reforms challenge the balance of power between the executive and legislative branches. Existing processes already encourage the employment of some capital budgeting analytical processes; the specific remedies proposed are unlikely to resolve the problems of cost management. Indeed, they may create new problems.

## Rational Cost Model Reforms

The second area of reform concerns the cost estimate on which the investment decision and budget are based. As the GAO recently stated, “If we expect programs to be executed within budget, programs need to begin with realistic budgets. The foundation of an executable budget is a realistic cost estimate that takes into account the true risk and uncertainty in a program” (GAO, 2007, p. 17). There is widespread dissatisfaction with the accuracy of defense cost estimating—both in Congress and within the DoD. When a program experiences cost growth above its budgeted amount, the allocation of funds in current or future-year budgets must be adjusted to keep the program on track; doing so requires either top-line relief or a decrease to one or more other program budgets. Either way, expectations are unmet. Before evaluating some of the proposed remedies to this problem, we must understand the nature of the problem.

Of course, one must acknowledge that the cost-growth problem involves three variables. First is the cost estimate ( $E$ ), which is often cited as a discrete figure, but in reality is a range of values defined by a probability distribution. Second is the amount budgeted ( $B$ ) for the program,<sup>5</sup> which is a discrete value selected presumably from somewhere along the cost-estimate probability curve. Third is the final cost of the program ( $C$ ), a discrete value. The public often scrutinizes the difference between  $B$  and  $C$ , as these are the figures that exist in budget or appropriation documents, contract audits, SAR reports, and the like. Scholars and management reformers tend to also focus on the relationship between  $E$  and  $B$ , but the nuances often fail to capture the public’s and politicians’ interest.

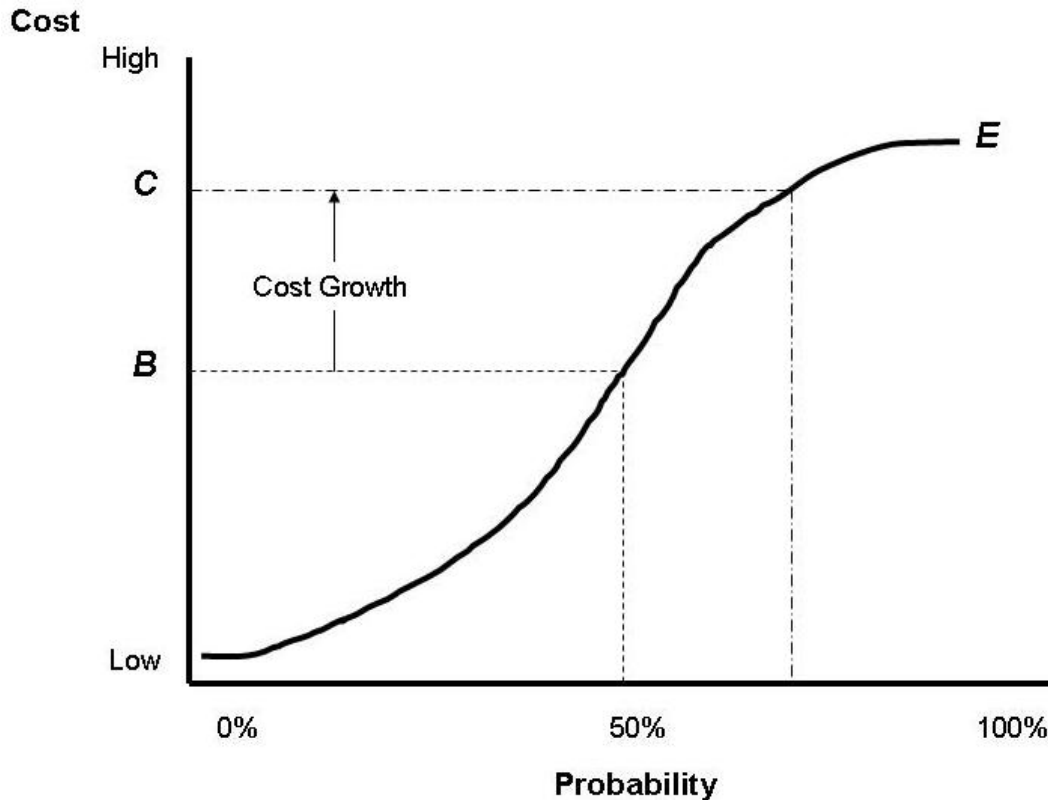
Shown graphically in Figure 1, a notional cost-estimate S-curve (so called because of its shape) will define a probability distribution based on the confidence of data populating the estimating model and the accuracy of the model itself ( $E$ ). There is little probability of the government meeting the cost estimate at the low-dollar-value end of the curve, but a very high probability of meeting program goals at the high-dollar-value end of the curve. During the budgeting process, a value is selected along the curve at the appropriate amount of

---

<sup>5</sup> To be even more precise, one could break down this variable into the programmed amount, the budgeted amount, the appropriated amount, and the amount actually provided to the program office. Those distinctions, though often quite real, are not necessary to make here.

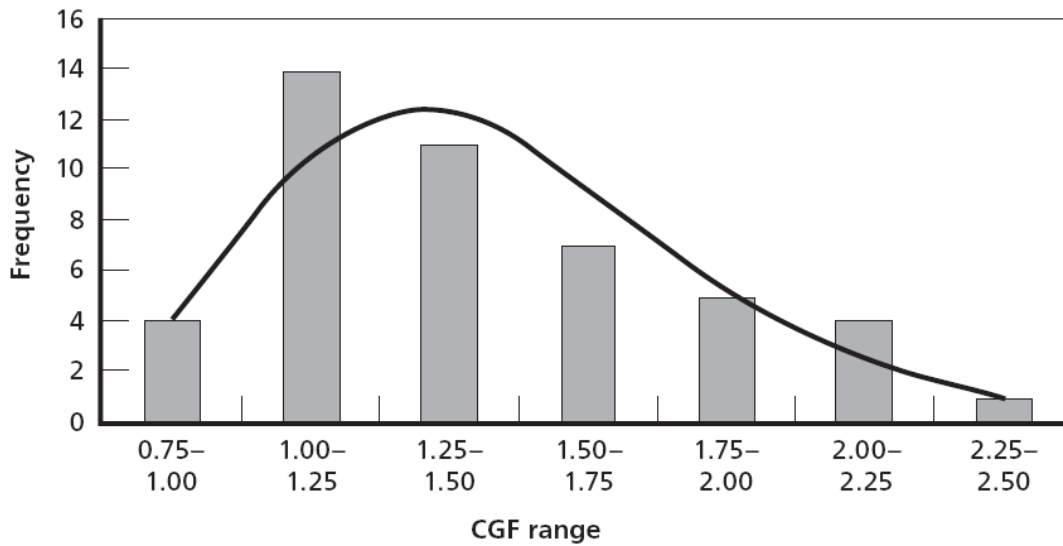


funds—the precise point on the curve is the subject of some reform proposals and will be discussed shortly. For illustration purposes, the 50% probability value is shown (*B*). Eventually, at program completion, one has a final cost, notionally shown on the chart at value *C*. Cost growth is generally considered the difference between *B* and *C*. Many definitions of cost growth select *B* at acquisition Milestone B and *C* at program completion (or latest estimate if still ongoing), and years may pass between the formulation of *B* and the eventuality of *C*.



**Figure 1. Cost Growth Diagram**

It is important to first note that cost-estimating errors, when they exist, are overwhelmingly low compared to the cost estimate. This author has yet to read a study or hear a defense official or politician complain that cost estimates are too high and overestimating errors are a problem. While this may seem facetious, it is a critically important point. If cost-estimating errors were a function of poor-quality data or technically inaccurate models, then one would expect normally distributed errors with a mean near zero. What we see is more of a lognormal distribution with very few observations of overestimation—as in Figure 2, below, from a RAND study. This distribution suggests that there are biases in the data or models. Thankfully, biases can be found and eliminated. That is what much of the research and many of the recommendations in this area seek to do.



**Figure 2. Cost-growth Factors (CGF) of Major Acquisition Programs**  
(Arena, Leonard, Murry & Younossi, 2006, p. 22)

What are the biases that affect cost estimates? RAND cites the following causes for cost growth: “overoptimism, estimating errors, unrecognized technical issues, requirements creep, lack of incentives to control cost, and schedule extensions” (Younossi et al., 2007, p. xxi). While unrecognized technical issues may indicate a poor estimate, *unrecognizable* errors do not. Most cost-estimating models make allowances for the likely ones; the unknowable ones should be distributed randomly, as should errors. Schedule extensions and requirements creep may help explain why final costs are higher than the estimate; however, they are not estimating problems if the changes to schedules and requirements occur subsequent to the estimate, and the estimate correctly considered the original schedule and requirement. Further, it is incorrect to view cost growth as a problem in a situation in which requirements grow, and the cost of those requirements—had they been considered—would have been consistent with the estimate. In those cases, the item purchased is not the same as the item estimated.<sup>6</sup> And in many cases, schedule extensions are an effect, not a cause, of cost growth. These are matters of program management discipline, not cost-estimating accuracy. A lack of incentives to control costs is also a matter of program management or oversight and is not a matter of cost estimating, directly. It may be an indirect factor, as we shall see below. That leaves overoptimism as a source of non-normal bias in the estimate.

Melese and his co-authors blame two factors: “bad incentives (psychological and political-economic explanations) and bad estimation (methodological explanations)” (Melese et al., 2007, p. 359). Similarly, Flyvbjerg (2006) cites three categories of factors. One (technical estimating errors) he dismissed because of the non-normal distribution of errors

<sup>6</sup> It is important here to acknowledge that, politically, this distinction may not matter. The public at large does not hold that information and only sees that the latest fighter (or ship or other program) has grown in cost. It does not see that the airplane that was bought is better than the one estimated.

and the general lack of improvement over time. The other two, optimism bias and strategic misrepresentation,<sup>7</sup> are characterized as psychological and political factors, respectively. Thus, all three studies identify similar biases, but they suggest different remedies.

The problem is that two types of bias exist in cost estimating: optimism and strategic misrepresentation. These biases affect the cost estimate, the amount budgeted for the program, or both. There are other forces that affect the final cost figure and manifest during the execution of the program: requirements creep (including the unforeseen technical issues), some schedule extensions, and incentive structures. Let us consider three proposed remedies to the cost-estimating problem in light of these biases and factors.

*DAPA Recommendation—budget higher on the curve.* To its credit, the *DAPA* report did not look solely at cost-estimating errors, but rather at the totality of issues affecting defense acquisition.<sup>8</sup> As part of its authors' comprehensive examination, recommendations were offered in several areas, including budgeting and cost control. Among those budgeting and cost control recommendations was the proposal to "Adjust program estimates to reflect 'high confidence'—defined as a program with an 80% chance of completing development at or below estimated cost" (Kadish et al., 2006, p. 13). Acknowledging the overoptimism and strategic misrepresentation biases in the system, which they refer to as "the conspiracy of hope" (p. 102), the authors assert that using optimistic estimates (defined as the 50% confidence level) results in excessive restructuring of budgets and programs. Essentially, the *DAPA* report suggests an appropriate level of funding: that *B* should be set at a specific, higher, point on the *E* curve.

There is an attractive logic to the *DAPA* proposal. If *B* were set higher on the *E* curve, one can be reasonably certain that the degree of cost growth would diminish. Presumably, only 1/5 of programs would risk cost growth, and 4/5 should cost approximately what was budgeted. This would reduce the need for budgetary and programmatic adjustments, as far fewer programs would experience growth problems. This proposal, however, results in higher overall spending for the same programs.

Federal appropriation law and the norms of the federal government are such that every dollar appropriated is expected to be spent. If a program is funded at the 50% probability level, there is an even chance it will either cost what was budgeted or will cost more. In other words, there is nearly a 100% chance it will cost *at least* the 50% level. By funding that same program at the 80% probability level, there is zero chance that it will cost the amount of the 50% or the 60% or the 75% estimate. There is a nearly 100% probability it will cost at least the 80% estimate. While funding at the higher level reduces the likelihood of cost growth, it does so by guaranteeing the higher cost in the first place. There is no longer the possibility of a negative effect on other programs; it is foreordained. Rather than risk the

---

<sup>7</sup> Jones & Euske define strategic misrepresentation as "the planned, systematic distortion or misstatement of fact—lying—in response to incentives in the budget process" (1991, p. 437). This definition is consistent with Flyvbjerg's use of the term.

<sup>8</sup> The report warns that one should implement comprehensive change rather than incremental change. "Past practices are replete with examples demonstrating that if you adjust one part of the system with corrective measures, challenging issues surface in other parts of the system. When untested corrective action is taken, over time it can result in unintended consequences" (Kadish et al., 2006, p. 82). This author agrees wholeheartedly; in fact, the purpose of this report is to draw attention to those unintended consequences.





possibility of disrupting secondary programs or altering schedules and reducing quantities of the primary program, those changes necessarily occur at the outset.

*Melese et al. Recommendation—TCE.* In a study that looked specifically at cost-estimating accuracy, Melese and his colleagues employ transaction cost economics (TCE) theory to the problem of cost growth. While acknowledging the psychological and political biases that create bad incentives, they mainly focus on improving bad estimation methodologies. The authors suggest the use of TCE will obtain less biased estimates which, in turn, will reduce the mean and variance of cost growth. Noting that inaccurate estimates may result from omitting variables, the estimator is encouraged to consider costs beyond production to “include coordination and motivation costs such as search and information costs, decision and contracting costs, and monitoring and enforcement costs” (Melese et al., 2007, p. 359). After clearly describing factors within the DoD and their contractors that drive cost growth, the authors conclude that “cost estimating techniques must properly anticipate extra transaction costs [...] that can quickly overwhelm initial production cost estimates” (p. 365).

There are two concerns with this approach. First, “TCE predicts contracts and other governance structures will be chosen that reduce transaction costs and improve the gains from exchange between buyers and sellers” (p. 367). This is true only so far as both buyer and seller are motivated by a concern for economic efficiency. This is not necessarily true when one of the actors is a government. Rules governing competitive bidding, free trade, the use of small businesses, and *Buy-American* provisions all add transaction costs and often raise production costs. The public value in such rules is not economic; it is elsewhere in the complexion of values that define the public sector: values such as fairness, equity, accountability, or justice. The evidence is not at all clear that the DoD is motivated to design governance structures, for instance, that reduce transaction costs. The excessively bureaucratic structure of the acquisition review and approval processes is hardly designed to be efficient. Those processes are arguably designed to limit undesirable effects more than they are designed to encourage desirable ones.

Second, since acquisition cost growth is measured predominantly in production cost terms, the increases that are routinely experienced are in production costs; they are not caused by the omission of transaction costs. Cost growth is most commonly defined as increases in development and production costs as reported in *Selected Acquisition Reports*. In other words, those costs are the ones funded through RDT&E and procurement appropriations. The majority of the transaction costs, on the other hand, are funded in operations appropriations. Contracting, contract administration, auditing, data collection, oversight, etc., are neither included in the baseline nor in the final cost estimate.<sup>9</sup> The salary of the program manager is not even included. The omission of such costs does not account for the growth.

The value of a TCE approach comes from the knowledge that managing those activities may reduce cost growth, but including them in the estimate will not. Inclusion of

---

<sup>9</sup> Volume 2A, Chapter 1 of the DoD Financial Management Regulations says: “The cost of civilian personnel compensation and other direct costs (i.e., travel, office equipment leasing, maintenance, printing and reproduction) incurred in support of procurement and/or production programs by departmental headquarters staff, contracting offices, contract audit offices, system project offices, and acquisition managers are expenses.” As expenses, they are not funded in the procurement accounts.





those costs in the estimate would have the additional unintended consequence of ascribing an economic value to those activities above the other social values they were intended to create. Audits are done not to reduce cost but to provide accountability and assurance to the public. Governance structures exist not only to hold economic costs down, but also to ensure against waste and fraud and to ensure compliance with the law. Many of those laws are motivated by social, not economic values. Because of that, decision-makers should focus not on minimizing their drain on the acquisition of weapon systems, but rather on reducing the cost of attaining that social goal irrespective of the weapons system.

Undoubtedly, a better understanding of the role transaction costs play in the motivation of sellers can assist in the negotiation and administration of contracts; that may, in turn, help lower the cost of production. But because many of those transaction costs serve non-economic goals, they should remain outside the cost estimate and the final cost tally.

*Flyvbjerg Recommendation—reference class forecasting.* There is another way to address the psychological and political biases other than using TCE. Flyvbjerg (2006) recommends using reference class forecasting—an estimating methodology based on Kahneman and Tversky's (1979) work in decision-making under conditions of uncertainty. Reference class forecasting addresses optimism and strategic misrepresentation biases by relying on the actual performance of a reference class of comparable projects. To combat the optimistic bias inherent in an “inside view” of the project, under reference class forecasting, those estimating the cost of a project assume an “outside view” by considering the experiences of comparable projects. In his study of public works projects, Flyvbjerg finds that different classes of projects improve their cost-estimating accuracy by apply various “uplifts” to the inside view estimates. He finds that to achieve the 80% probability level (the same probability the *DAPA* report recommends), estimates for road, bridge/tunnel, and rail projects should rise 32, 55 and 57%, respectively.

Reference class forecasting suffers from the same effect as the *DAPA* recommendation: improvements in cost-estimating accuracy are achieved by forfeiting the possibility of lower total costs. Reference class forecasting is not a new idea for defense acquisition. The “outside view” was the motivation for the creation of the Cost Analysis Improvement Group in 1972 and the requirement for independent cost estimates (Melese et al., 2007). The Congressional Budget Office employs this basic concept in their report series *Long-term Implications of Current Defense Plans* (CBO, 2007). The knowledge exists. One could even assume it is considered by decision-makers; it simply is not used. The important question is why not?

All three studies suggest remedies to improve the accuracy of cost estimates and to lower the likelihood of cost growth in defense acquisition. They each acknowledge that cost growth is less a technical estimating problem as it is a problem of psychological and political bias. The three recommendations would all bring *B* closer to *C* on Figure 1 and would be able to claim gains in cost-estimating accuracy. This paper concedes that such methods are likely to reduce cost growth, but it also warns that they do little to address the ultimate problem of total cost. In fact, all three recommendations would aggravate rather than mitigate the ultimate problem: high costs crowding out other spending and their effect on military force structure. Why? Because all three methods program those costs with certainty rather than risk the possibility of them occurring later.



One should notice that all three methods suggest that the DoD more fully consider costs known to exist. I submit that those costs are considered and intentionally dismissed for one of two reasons. One reason—acknowledged by Melese et al. and Flyvbjerg—is that a lower estimate may be politically necessary to achieve the “camel’s nose in the tent” effect. Wildavsky (1979) suggested that low initial budget estimates, while inaccurate, serve a useful purpose by getting a program initiated. Then, once it is initiated, upward adjustments are easier to obtain in the future than approval of the program at the higher amount in the first place. Strategic misrepresentation (Flyvbjerg, 2006; Jones & Euske, 1991) is a common occurrence and one not undertaken lightly. Those engaging in strategic misrepresentation weigh the benefit of a higher probability of program initiation against the higher probability of a cost to one’s reputation and the inevitable downstream budget pressure. Evidently, in some cases, the balance tips in the favor of under-representing cost.

Another reason for underestimating is that the Defense Department may be wittingly or unwittingly engaging in target costing (Monden & Hamada, 1991; Cooper & Slagmulder, 1997). Target costing is the practice of intentionally setting aggressive financial targets as an inducement to achieve those targets. It is done with full knowledge that there is a risk of cost growth, but that risk is accepted in exchange for the possibility of hitting the lower actual cost. Costs are managed through value engineering programs. The Navy’s recent goal of producing a Virginia class submarine for \$2 billion is an example. Target costing is the opposite of what the three studies recommend. Target costing can be effective if the environment is such that: (a) program managers are not punished for missing cost goals if their actual performance is reasonable, and (b) resources are slack enough to cover the inevitable cost growth. Both conditions tend to exist in the DoD.

Whether the reason for perpetuating low estimates is an example of the camel’s nose theory or target costing, such low estimates are of value to the DoD. In the first case, a desired but politically risky program is begun and, once begun, is likely to perpetuate. In the second case, pressures are applied to programs to hold costs down, and the possibility of actually hitting those ambitious targets is left open. The two reasons may co-exist: through ambitiously low estimates, sufficient resources are apparently made available to initiate a new program. In some cases, this is evidently preferable to raising the estimate of the first program to reduce the likelihood of cost growth and, consequently, to eliminating the possibility of initiating the second.

Paradoxically, it is the dissatisfaction with cost growth that permits practices like target costing to work, and it is the dissatisfaction with cost growth that limits the use of strategic misrepresentation. Funding at a low level of probability can be revisited during the annual budget cycle, but in the presence of constrained resources and dissatisfaction with cost growth, program managers are pressured to hit those ambitious targets and minimize growth. These existing practices likely hold total costs lower than would be the case if the recommendations were adopted. Why? Those recommendations relieve the pressure to contain cost growth but do so in exchange for nothing other than the satisfaction of having met the estimate. Defense behavior has shown that two programs bursting at the budget seams is preferable to one program managed comfortably.

## Conclusion

Dissatisfaction with cost growth has generated a set of recommendations designed to eliminate that growth. Unfortunately, adopting an inappropriate or unnecessary model



may not be helpful; rigidity is not helpful when flexibility is needed, and foreordaining higher costs is not helpful. The dissatisfaction itself is helpful.

Recall that the main concern with cost growth is that it affects the total defense program. Systems are delivered later or in smaller quantities than expected. Root causes of the growth are psychological and political biases that manifest in the behavior of programmers, program managers, budgeters, contractors and politicians. These biases exist for a reason, and accounting for them does not make them disappear. Accounting for them simply makes explicit what many actors in the system know implicitly. Failing to account for them serves to add pressure and incentives to the system, which may result in holding costs lower than they would be if the biases were accounted for.

The underlying concern should be spending in total—not spending relative to an estimate. However, defense leaders and stakeholders should not be complacent about growth because their dissatisfaction serves a useful purpose. Rather than eliminate that dissatisfaction, it should be understood for the role it plays. Indeed, the present state may very well have evolved—not unlike Darwin’s finches—to achieve a satisfactory balance among all the forces at play: in this case, economic, psychological and political ones.

## List of References

- Arena, M.V., Leonard, R.S., Murray, S.E., & Younossi, O. (2006). *Historical cost growth of completed weapon system programs* (Report TR-343-AF). Santa Monica, CA: RAND. Retrieved March 19, 2008, from [http://www.rand.org/pubs/technical\\_reports/TR343/](http://www.rand.org/pubs/technical_reports/TR343/)
- CBO. (2007, December). *Long-term implications of current defense plans: summary update for fiscal year 2008* (Publication Number 2966). Retrieved February 20, 2008, from <http://www.cbo.gov/ftpdocs/88xx/doc8844/12-13-LT-Defense.pdf>
- Cooper, R., & Slagmulder, R. (1997). *Target costing and value engineering*. Portland, OR: Productivity Press.
- Francis, D.B., & Walther, R.J. (2006). *A comparative history of Department of Defense management reform from 1947 to 2005* (Center for Defense Management Reform Report NPS-CDMR-GM-06-009). Retrieved March 8, 2008, from [http://defensereform.org/\\_files/FY2006/NPS-CDMR-GM-06-009.pdf](http://defensereform.org/_files/FY2006/NPS-CDMR-GM-06-009.pdf)
- Flyvbjerg, B. (2006). From Nobel Prize to project management: Getting risks right. *Project Management Journal*, 37(3), 5-15.
- GAO. (2005). *Best practices: Better support of weapon system program managers needed to improve outcomes* (GAO-06-110). Retrieved July 9, 2007, from <http://www.gao.gov/new.items/d06110.pdf>.
- GAO. (2007, January). *High risk series: An update* (GAO-07-310). Retrieved February 20, 2008, from <http://www.gao.gov/new.items/d07310.pdf>.
- GAO. (2007, March). *Defense acquisitions: Assessments of selected weapon programs* (GAO-07-406SP). Retrieved February 20, 2008, from <http://www.gao.gov/new.items/d07406sp.pdf>.
- GAO. (2007). *Defense acquisitions: Realistic business cases needed to execute Navy shipbuilding programs* (GAO-07-943T). Washington, DC: Author.
- Housel, T., & Bell, A.A. (2001). *Measuring and managing knowledge*. New York: McGraw Hill/Irwin.
- Jones, L.R., & Euske, K.J. (1991). Strategic misrepresentation in budgeting. *Journal of Public Administration Research and Theory*, 1(4), 437-460.



- Kadish, R., Abbott, G., Cappuccio, F., Hawley, R., Kern, P., & Kozlowski, D., et al. (2006). *Defense acquisition performance assessment report for the Deputy Secretary of Defense*. Retrieved April 18, 2007, from <http://www.acq.osd.mil/dapaproject/>
- Kahneman, D., & Tversky, A. (1979). Prospect theory: An analysis of decision under risk. *Econometrica*, 47(2), 263-292.
- Kreig, K. (2007). *Defense acquisition transformation report to Congress*. Washington, DC: DoD.
- Lee, R.D., & Johnson, R.W. (1998). *Public budgeting systems* (6th ed). Gaithersburg, MD: Aspen Publishers.
- McCaffery, J.L., & Jones, L.R. (2006). *Reform of budgeting for acquisition: Lessons from private sector capital budgeting for the Department of Defense* (NPS-FM-06-029). Monterey, CA: Naval Postgraduate School. Retrieved May 2007, from [http://acquisitionresearch.org/index.php?option=com\\_content&task=view&id=104&Itemid=41](http://acquisitionresearch.org/index.php?option=com_content&task=view&id=104&Itemid=41)
- Melese, F., Franck, R., Angelis, D., Dillard, J. (2007). Apply insights from transaction cost economics to improve cost estimates for public sector purchases: The case of U.S. Military Acquisition. *International Public Management Journal*, 10(4), 357-385.
- Monden, Y., & Hamada, K. (1991). Target costing and Kaizen costing in Japanese automobile companies. *Journal of Management Accounting Research*, 3, 16-34.
- Wildavsky, A. (1979). *The politics of the budgetary process* (3<sup>rd</sup> ed.). Boston, MA: Little Brown.
- Younossi, O., Arena, M.V., Leonard, R.S., Roll, C.R., Jr., Jain, A., & Sollinger, J.M. (2007). *Is weapon system cost growth increasing?: A quantitative assessment of completed and ongoing programs* (MG-588-AF). Santa Monica, CA: RAND. Retrieved February 20, 2008, from [http://www.rand.org/pubs/monographs/2007/RAND\\_MG588.pdf](http://www.rand.org/pubs/monographs/2007/RAND_MG588.pdf)



## Panel 13 - Perspectives on COTS Implementation

---

<b>Thursday, May 15, 2008</b>	<b>Panel 13 - Perspectives on COTS Implementation</b>
<b>11:15 p.m. – 12:45 a.m.</b>	<b>Chair:</b>  <b>Stan Z. Soloway</b> , President, Professional Service Council  <b>Discussant:</b>  <b>CAPT Stephen H. Huber</b> , Commander, Port Hueneme Division, Naval Surface Warfare Center  <b>Papers:</b>  <b><i>Commercial-Off-the-Self (COTS); Doing It Right</i></b>  <b>Dr. William Lucyshyn</b> , Director of Research and Senior Research Scholar, Center for Public Policy and Private Enterprise, University of Maryland  <b><i>Commercial-Off-the-Self (COTS): Impact to Reliability, Maintainability and Availability (RM&amp;A) from an In Service Engineering Perspective</i></b>  <b>Robert Howard</b> , Systems Engineering and T&E Division Supportability Manager, Land Attack Department, Naval Surface Warfare Center, Port Hueneme Division

**Chair: Stan Z. Soloway** is president of the Professional Services Council—the principal national trade association representing the government professional and technical services industry. PSC is known for its leadership on the full range of government acquisition/procurement and outsourcing and privatization issues. Soloway assumed the presidency in January 2001.

Soloway is an expert on the relationship between the public and private sectors, and is routinely sought out by the media, federal agencies, congress and others to provide commentary and perspective on the full range of procurement and outsourcing issues. He also writes a monthly column in *Washington Technology* magazine, and was a member of the congressionally mandated, national panel on the future of government outsourcing chaired by the Comptroller General of the US.

Prior to joining PSC, Soloway served as the Deputy Under Secretary of Defense (Acquisition Reform) and concurrently as director of Secretary of Defense William Cohen's Defense Reform Initiative. As Deputy Under Secretary, he was the department's senior official responsible for the development and implementation of far-reaching reforms to the DoD's acquisition processes and policies, and for the oversight of the training, education and career development of the 200,000-member defense acquisition workforce. As director, DRI, Soloway led significant department-wide re-engineering and reform initiatives in areas as diverse as privatization and outsourcing, electronic commerce, financial management reform, logistics transformation, and the quality of life for American troops.

In recognition of his leadership at the DoD, Soloway was awarded both the Secretary of Defense Medal for Outstanding Public Service and the Secretary of Defense Medal for Distinguished Public Service.





In 2007, Soloway was confirmed by the US Senate for a seat on the bi-partisan Board of Directors of the Corporation for National and Community Service. Mr. Soloway is a principal of the Council on Excellence in Government, and was an expert panelist for studies conducted by the Center for Strategic and International Studies on the future of defense technology and acquisition policy. He is also a member of the Board of Advisors of the National Contract Management Association, was a 2005 recipient of the prestigious Federal 100 Award, and speaks frequently to industry and government organizations on government technology, acquisition, human capital, and strategic management issues.

Before his appointment to the DoD, Soloway was a public policy and public affairs consultant for more than 20 years, and a highly regarded expert in (and frequent lecturer on) acquisition, privatization, and outsourcing issues. He also co-produced the critically acclaimed "Great Confrontations at the Oxford Union," a series of prime-time specials that aired nationally on public television. He earned a degree in Political Science from Denison University, where he was elected to the National Men's Journalism, National Men's Leadership, and National Political Science honorary societies.

**Discussant: Captain Stephen H. Huber** was born in West Chester, PA. He graduated from the US Naval Academy and was commissioned in 1980, having earned a Bachelor of Science Degree in Oceanography/Physics. After graduation, Huber served as a Naval Academy Seamanship and Navigation Instructor, followed by Surface Warfare Officers' School in Coronado, CA. At sea, he has served aboard USS STEIN (FF 1065) as Gunnery Officer, ASW Officer and Navigator/Administrative Assistant; USS REASONER (FF 1063) as Weapons Officer; and USS GARY (FFG 51) as Executive Officer. He also served on the Afloat Staff of Destroyer Squadron 5 as Operations Officer, and on the staff of Commander, THIRD Fleet, as Flag Secretary. Huber was Commanding Officer in USS FIFE (DD 991) from September 1998 through April 2000. During his command tour, FIFE deployed to the Eastern Pacific in support of Counter-Narcotics Operations, was the first ship to go through an availability using a private contractor in a public shipyard, and was awarded the SECNAV Energy Conservation Award. Ashore, Huber has served as Aide to the Commandant, Naval District Washington, DC, and on the staff of Commander in Chief, US Atlantic Fleet, as the Assistant Surface ASW Officer and Special Operations Officer.

During tours in Washington, DC, he has served as the Combat Systems Training Officer on the staff of the Chief of Naval Operations and at NAVSEA, in the Surface Ship Technology Directorate (SEA 53) and as Deputy Program Manager in PMS 430—the BFTT program office. His last assignment was as Deputy Director, Human Systems Integration Directorate (SEA 03B).

Huber assumed command of Port Hueneme Division, Naval Surface Warfare Center in May 2004. Under his command, Port Hueneme Division has been awarded the 2006-2007 Shingo Silver Medallion in the Public Sector Category; the California Award for Performance Excellence, Bronze level 2005 and Silver level 2006; the Deming Award for Training Excellence 2005; the Department of Veterans Affairs Government Contracting Office/Facility Award during 2005; was the NAVSEA Nominee for the CNO Safety Award 2005; the 2006 CNO Environmental Award; and received the Industry Partnership Award from the California Regional Consortium for Engineering Advances in Technological Education (CREATE), 2006. A strong supporter of the Navy's Lean Six Sigma initiatives, Huber's leadership has resulted in recorded savings in excess of \$26 million during his tour.

Huber's awards include the Meritorious Service Medal (with two gold stars), the Navy Commendation Medal (with four gold stars), the Navy Achievement Medal, and several unit awards. He holds a Master of Arts degree in International Studies from Old Dominion University, and a Master of Arts degree in National Security and Strategic Studies from the Naval War College. He was inducted into the International History Honors Society, Phi Alpha Theta, in 1993. He was designated an Acquisition Professional in January of 1997 and DAWIA Level III certified in Program Management in February of 2002. He was a 2003 National Security Studies Fellow at the Maxwell School, Syracuse University.



# Commercial-Off-the-Self (COTS): Impact to Reliability, Maintainability and Availability (RM&A) from an In Service Engineering Perspective

---

**Presenter: Robert Howard**, Systems Engineering and T&E Division Supportability Manager, Land Attack Department, Naval Surface Warfare Center, Port Hueneme Division

---

## Abstract

With the proliferation of COTS within Military systems based on DoD acquisition directives, RM&A processes and products requirements during acquisition need to evolve to ensure systems are meeting lifecycle expectation. RM&A disciplines and products have limited focus based on traditional MIL-STD architecture, which was based primarily on hardware failures represented by the traditional bathtub curve. This paper discusses some of key observations and solutions being applied from the In-service Engineering Agent (PHD NSWC) along with lessons observed to mitigate future risks.

Acquisition development strategies (such as incremental and spiral) are utilizing more COTS components for hardware and open architecture computing strategies for software. This drives a necessity to reevaluate traditional RM&A efforts performed during concept, development, integration and fielding. It also forces decision-makers to assess fleet feedback systems and their capability to provide meaningful data to understand and perform root-cause analysis on issues impacting operational availability, manpower, and operational cost. Lifecycle RM&A observations were made on the level of accuracy and confidence required to support COTS Refresh Selection, changes in Duty Cycle and their relative impact to failure-rate calculation, reduced applicability of the Bath Tub Curve for RM&A prediction, and Human System Interface (HSI) impacts to failure rate. Through understanding of these observations, this paper provides insight into reducing and avoiding introduction and sustainment risks and costs associated with COTS and OA.

The in-service engineer must be involved through government oversight to verify both that system requirements are articulated and captured to the appropriate level to reach the desired end-state and that RM&A analysis tools are adapted based on technology insertion. During development, production, and systems integration, the in-service engineer must ensure OEMs capture data and indicators which could identify shortfalls in planned or completed analysis, as these could impact the expected reliability, maintainability, or supportability of the system. Finally, as systems are fielded, assessment of quantitative feedback mechanism must be complimented with qualitative feedback if decision-makers are to identify if reporting shortfalls exist for the receipt of fleet feedback on RM&A issues.





THIS PAGE INTENTIONALLY LEFT BLANK



## Panel 14 - Issues in Cost Estimating for US Naval Shipbuilding

---

<b>Thursday, May 15, 2008</b>	<b>Panel 14 - Issues in Cost Estimating for US Naval Shipbuilding</b>
<b>11:15 a.m. – 12:45 p.m.</b>	<p><b>Chair:</b></p> <p><b>Christopher S. Deegan</b>, Division Director, Cost Engineering and Industrial Analysis Division, Naval Sea Systems Command</p> <p><b>Papers:</b></p> <p><b><i>Submarine Cost Analysis</i></b></p> <p><b>LT Ben Grant</b>, Graduate Student, Naval Postgraduate School</p> <p><b><i>Dynamic Cost Risk Assessment for Controlling the Cost of Naval Vessels</i></b></p> <p><b>Dr. Edouard Kujawski</b>, Associate Professor, <b>Jeffery E. Kline</b>, Program Director of Center of Executive Education and <b>Dr. Diana Angelis</b>, Associate Professor, Naval Postgraduate School</p> <p><b><i>Using the Steel Vessel Material-cost Index to Mitigate Shipbuilder Risk</i></b></p> <p><b>Edward G. Keating</b>, Senior Economist, <b>Robert Murphy</b>, Researcher, <b>John F. Schank</b>, Senior Operations Research Analyst and <b>John Birkler</b>, Research Leader, Acquisition, Defense Production, and Technology Base Issues, RAND Corporation</p>

---

**Chair: Christopher S. Deegan**, Division Director, Cost Engineering and Industrial Analysis Division, Naval Sea Systems Command

---



# Dynamic Cost Risk Assessment for Controlling the Cost of Naval Vessels

---

**Presenter: Dr. Edouard Kujawski** is an associate professor in the Systems Engineering Department at the Naval Postgraduate School. His research and teaching interests include the design and analysis of high reliability/availability systems, risk analysis, and decision theory. He received a PhD in theoretical physics from MIT, following which he spent several years in research and teaching physics. He has held lead positions at General Electric, Lockheed-Martin and the Lawrence Berkeley National Laboratory. He has contributed to the design of particle accelerators and detectors, space observatories, commercial communication systems, the Space Station, and nuclear power plants. He was a participant and contributor to the Lockheed Martin *LM21 Risk Management Best Practices* and the original *INCOSE Systems Engineering Handbook*. He is a member of the San Francisco Bay Area Chapter of INCOSE and has served on the board of directors.

Edouard Kujawski  
Systems Engineering Department  
Naval Postgraduate School  
Monterey, California 93943

**Author: Dr. Diana Angelis** is an Associate Professor in the Defense Resources Management Institute at the Naval Postgraduate School in Monterey, CA. She joined the faculty in 1996. She studied accounting at the University of Florida and received a BS in Business Administration in 1977 and a BS in Electrical Engineering in 1985. She received her PhD in Industrial and Systems Engineering from the University of Florida in 1996. Her research interests include the application of activity-based costing in government organizations, cost estimating, the valuation of R&D through options theory, and business reforms in defense management. She was commissioned an officer in the United States Air Force in 1984 and served as a program engineer until 1989. She joined the USAF Reserves in 1990 and has worked in both acquisition and test & valuation with the Air Force Materiel Command. Dr. Angelis is a Certified Public Accountant and a Lieutenant Colonel in the US Air Force Reserve currently assigned to the Air Force Flight Test Center at Edwards AFB, CA.

Diana Angelis  
Defense Research Management Institute  
Naval Postgraduate School  
Monterey, California 93943

---

## Abstract

Naval vessels, like most large-capital projects, have a long history of cost growth. To get a handle on this problem, NAVSEA's Cost Engineering & Industrial Division, NAVSEA 05C, has introduced Probabilistic Cost Risk Analysis (PCRA) into the Department of Defense (DoD) Planning, Programmatic, Budgeting, and Execution System (PPBES). The quantification of cost in terms of cumulative probability distribution functions (CDF) or "S-curves" provides a macroscopic view of project risk. Risk curves alone do not provide adequate visibility into the individual project risk drivers; therefore, they are insufficient for planning and managing risk reduction activities (RRA). Complex projects typically involve a set of high-consequence, project-specific risks that require detailed analysis and for which risk response actions need to be developed and implemented. The analysis of specific risks and RRAs requires a microscopic view. We present a practical and mathematically sound approach using scenarios and Monte Carlo simulation within the framework of decision trees and risk curves. The approach is detailed using a realistic but simplified case of a project with three technical risks.



## Introduction

Cost growth has been a major problem for the US Navy. Over the past four decades, the growth of US Navy ship costs has exceeded the rate of inflation. In the past 50 years, annual cost escalation rates for amphibious ships, surface combatants, attack submarines, and nuclear aircraft carriers have ranged from 7 to 11% (Arena, Blickstein, Younossi & Grammich, 2006). Along with real cost growth, the DoD has had significant problems with cost estimates. By and large, the DoD and the military departments have underestimated the cost of buying new weapon systems. A recent study by RAND (Arena, Leonard, Murray & Younossi, 2006) indicates that there is a systematic bias toward underestimating weapon system costs and substantial uncertainty in estimating the final cost of a weapons system.

The DoD recognizes that uncertainty is an important part of cost estimating. During a 2007 seminar with a naval aviation program official, the Assistant Secretary of the Navy for Research, Development and Acquisition, Dr. Etter (Burgess, 2007), stated:

Program managers not only need to know a realistic cost estimate for their program, they need to know the percent probability of achieving that target. For example, a ship with a 40% chance of coming in on budget has a 60% chance of being over budget. Such a situation should prompt the project manager to seek help from the acquisition community. (p. 42)

There is an ongoing major shift in R&D and complex engineering projects from deterministic to probabilistic approaches. Probabilistic Cost Analysis (PCA) provides the proper framework for handling the many different elements of cost uncertainty, including project-specific, high-consequence risks. These risk drivers must be identified, assessed, mitigated, and controlled through formal risk management—which is an essential and critical discipline implemented in today's DoD projects. *The Risk Management Guide for DoD Acquisition* (2006) reads:

Risk management is a continuous process that is accomplished throughout the life cycle of a system. It is an organized methodology for continuously identifying and measuring the unknowns; developing mitigation options; selecting, planning, and implementing appropriate risk mitigations; and tracking the implementation to ensure successful risk reduction. Effective risk management depends on risk management planning; early identification and analyses of risks; early implementation of corrective actions; continuous monitoring and reassessment; and communication, documentation, and coordination. (p. 3)

The DoD considers the definition, implementation and documentation of risk management essential to acquisition success. The DoD risk management process outlined in the Risk Management Guide consists of the following five activities performed on a continuous basis: Risk Identification, Risk Analysis, Risk Mitigation Planning, Risk Mitigation Implementation, and Risk Tracking.

This process is consistent with the AACE definition, which includes identifying and analyzing risk factors or drivers, mitigating the risk drivers where appropriate, estimating their impact on plans and monitoring and controlling risk during execution (Hollman, 2006). To be effective, PCA must interface with each of the risk management activities.



An emphasis on risk management supports efforts to reduce lifecycle costs of system acquisitions. An often-neglected concept in project risk management is the consideration of the entire project lifecycle. Analysis of risk over the lifecycle of a system can yield substantial benefits. Conversely, ignoring important stages of the lifecycle can lead to substantial problems in terms of risk for product development at the beginning of the lifecycle and for product upgrade or replacement at the end (Pennock & Haimes, 2001).

Many sources of cost uncertainty in naval vessel construction—such as economic/business factors (rates-wages, overhead, G&A, vendor/supplier stability, inflation indices, multi-year assumptions, etc.), learning/rate/curve assumptions, and cost-reduction initiatives—are well understood within the framework of a macroscopic perspective; these are effectively modeled with classical Probability Distribution Functions (PDF) such as the triangular, Beta, lognormal, and Weibull distributions. However, these factors constitute only a fraction of today's typical project risk drivers and, therefore, cost uncertainty.

The construction of naval vessels, like most complex engineering projects, is also susceptible to project-specific risk drivers, such as: low Technology Readiness Level (TRL); high design, manufacturing, and complexity; significant requirement changes; sizeable quantity changes; large funding uncertainty; severe acts of nature; and serious accidents.

It is tempting to assume or claim that the PDFs typically elicited for cost elements also quantify the project-specific, high-consequence risks. Sometimes cost analysts will go through the effort of identifying and discussing risk drivers, but when it comes to quantifying the risks and estimating contingency, they simply apply high/low ranges to WBS elements without thinking about how a particular risk driver affects one or more cost elements. We think it is invalid and counterproductive to do this because it leads to the loss of valuable information and visibility into these risks. Also, this approach tends to focus on cost reduction rather than risk mitigation. Hollmann (2007) notes that in best practice, risk analysis should begin with the identification of risk drivers and events. The cost impacts of the risk drivers and events are then considered specifically for each event.

The analysis of specific risks and Risk Response Actions (RRA) requires a microscopic view and is best carried out with tools such Decision Trees (DT), influence diagrams, or other discrete representations. This microscopic perspective offers many benefits. It is a powerful risk analysis method to explicitly model high-consequence risks and RRAs, and thereby provides a tool for making better decisions. It also assists subject-matter experts (SMEs) to think about credible, high-consequence events and better deal with overconfidence or optimism biases. However, the microscopic view is too cumbersome to individually analyze every risk and source of cost uncertainty. It complements and needs to be integrated within the PCA.

In this paper, we propose to develop a microscopic/macroscopic PCA as an integral entity of the DoD risk management process, as follows:

1. The cost and/or risk analyst (simply referred to as analyst below) and the SMEs jointly identify the individual risks using the standard DoD risk-identification process.
2. The analyst and the SMEs jointly screen the identified risks for further analysis and risk mitigation.
3. The analyst and SMEs jointly identify realistic RRAs for the screened risks.



4. The analyst models each risk and its RRAs using a DT.
5. The analyst works with the SMEs to quantify the value of the decisions and outcomes for each DT using discrete and continuous distributions. We favor the Direct Fractile Assessment (DFA) method for data elicitation and fitting the associated cost elements with a three-parameter Weibull distribution.
6. The analyst quantifies the DTs using Monte Carlo simulation. Risks and RRAs are then modeled in terms of risk curves. We, thereby, avoid relying on the minimum expected risk value, which is a serious shortcoming of standard decision analysis.
7. The analysis is readily performed using commercial Excel add-ins (Crystal Ball, @Risk...) or more specialized tools (DecisionPro, Analytica...).

The goal of this paper is to present a realistic and practical method for explicitly analyzing and controlling the cost impact of project risks and realistic RRAs. Projects can then dynamically determine the optimal temporal set of decision gates for a given probability of success—thereby reducing cost while increasing the probability of project success. We illustrate the method using a realistic but simplified case of a project with three technical risks. We close with some concluding remarks and recommendations for further development.

## The Quantification of Multiple Project Risks

Consider a project with  $n$  credible, high-consequence risks  $\{R_i\}$ . Each risk,  $R_i$ , is characterized by a probability of occurrence  $p_i$  and a spectrum of possible outcomes with a PDF  $L_i(x)$ , where  $x$  is a random variable that represents the magnitude of the associated cost or loss. One may then think of this set of risks as a risk portfolio or repository (Kujawski & Miller, 2007) with a generalized discrete PDF  $R_S(x)$  given by:

$$R_S(x) \equiv \left\{ \langle p_1, L_1(x) \rangle, \langle p_2, L_2(x) \rangle, \dots, \langle p_n, L_n(x) \rangle, \left\langle 1 - \sum_{i=1}^n p_i, 0 \right\rangle \right\} \quad (1)$$

The total project cost is a random variable that consists of the sum of the  $m$  base cost elements  $\{BC_i\}$  and the explicitly identified risk costs  $\{RC_i\}$ . Depending on the state of knowledge of the data, the base cost elements  $BC_i$  may be modeled as either point estimates or continuous PDFs. The total project cost  $TC$  is then the probabilistic sum of the  $m$  base cost elements and  $n$  risk-driver costs:

$$TC(x) = \sum_{i=1}^m BC_i(x) + \sum_{i=1}^n p_i L_i(x) \quad (2)$$

Equations (1) and (2) provide visibility into the link between the credible, high-consequence risks  $\{R_i\}$  and the total project cost-risk curve. Monte Carlo simulation tools such as Crystal Ball and @Risk can also provide tornado charts that conveniently quantify the importance of the various risk drivers and their link to the overall cost risk. Projects can use this information to rationally identify risks. This is in sharp contrast with: (1) the use of point estimates that are at best ambiguous because overly confident staff provide low cost estimates, while others may inflate their cost estimates to make it easier to achieve success,



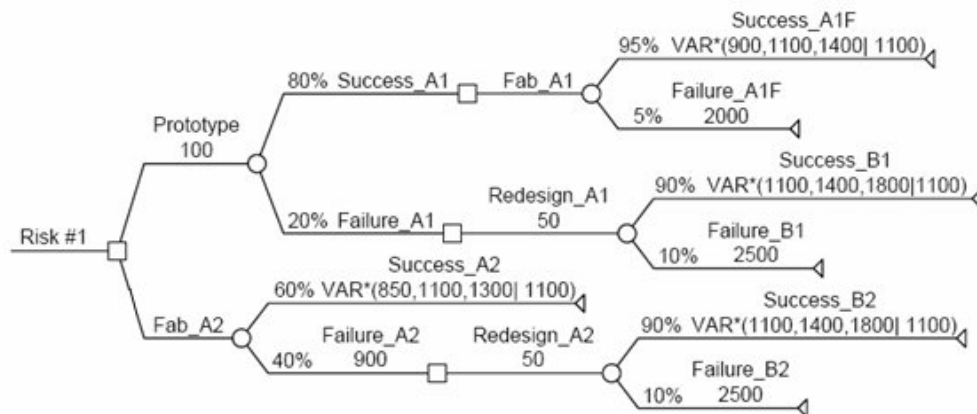
(2) decision-making based on qualitative assessments, and (3) the consideration of only S-curves, which only provide a macroscopic and somewhat “black box” view of project risk and cost uncertainty.

## Modeling and Analyzing Risk Response Actions

We model and analyze each screened risk and the proposed RRAs using a generalized DT—where PDFs rather than discrete branches are associated with the chance nodes, and the outcomes are analyzed using Monte Carlo simulation (Kujawski, 2002). This provides a powerful technique for dealing with the complex situations typical of today’s DoD projects. It avoids bushy trees and generates risk curves, thereby removing the reliance of decision-making based on expected value.

To illustrate the approach, consider the risk depicted in Figure 1. To be concrete, Risk #1 is associated with fabricating a complex module. The two risk response actions are: (i) Directly fabricate the module, or (ii) Build a prototype and then fabricate the module. The generalized DT follows the standard DT representation. Decision nodes and chance nodes are depicted as squares and circles, respectively. The branches that originate with decision nodes represent the available RRAs. The branches that originate with chance nodes represent the possible probabilistic outcomes. A descriptive label, a probability, and a cost distribution are associated with each branch. These probability and cost values are conditional on the RRA and may also be conditional on the outcome of other risks in case of interdependencies. We model the cost values using a three-parameter Weibull distribution fitted to the 10<sup>th</sup>, 50<sup>th</sup>, and 90<sup>th</sup> percentiles determined in accordance with the Direct Fractile Assessment (DFA) method.

In this example, we assume that the baseline cost is \$1,100K. Risk is then given by the Value At Risk (VAR) relative to this value. The VAR corresponds to the events whereby production of the module exceeds \$1,100K. The ordering of the decision nodes corresponds to different temporal deterministic events in the development and fabrication cycle of the module.



NOTE: In this hypothetical case, the values may be thought of as \$K.



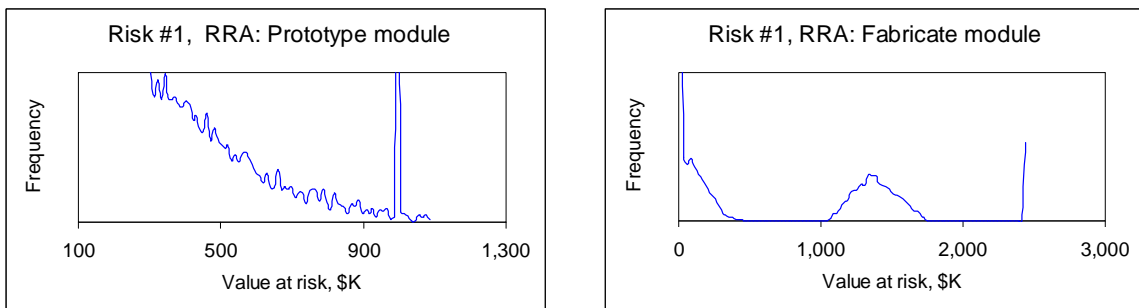


### Figure 1. Generalized Decision Tree for Risk #1 and Two Initial Candidate Risk Response Actions

We evaluated each RRA in Figure 1 using the Excel Monte Carlo simulation add-in, Crystal Ball. The selection of a RRA is a deterministic event, and only the associated outcomes can be realized. It would, therefore, be inappropriate to weigh or combine the outcomes of the two RRAs since they are mutually exclusive. The PDFs and risk profiles for each individual RRA at the start of the project are depicted in Figures 2a and 2b, respectively. The PDFs are multimodal and cannot be represented using any of the well-known probability distribution functions. The peak for the “prototype” RRA corresponds to the outcome in which the fabrication of the module fails. The PDF for the “direct fabrication” RRA has two modes corresponding to the sequence of events in which the first fabrication and the subsequent fabrication following redesign both fail.

The Complementary Cumulative Distribution Functions (CCDF) or risk curves are shown in Figure 2b, in which the exceedance probability is the probability of exceeding a given consequence or  $(1 - \text{the probability of success})$ . For example, looking at the VAR(Fab\_A2) curve in Figure 2b, one reads that there is approximately a 30% probability that the cost will exceed \$1,500K. Equivalently, one can state that there is a 70% probability that the cost will be less than \$1,500K. The risk curve and the cumulative distribution function carry identical information content. Since we are focusing on specific risks and VAR, we favor the risk curve or CCDF because, in our opinion, it provides a better view of the residual risk and management reserve than the S-curve (or CDF) that typical represents the total cost (including the baseline and risk cost elements).

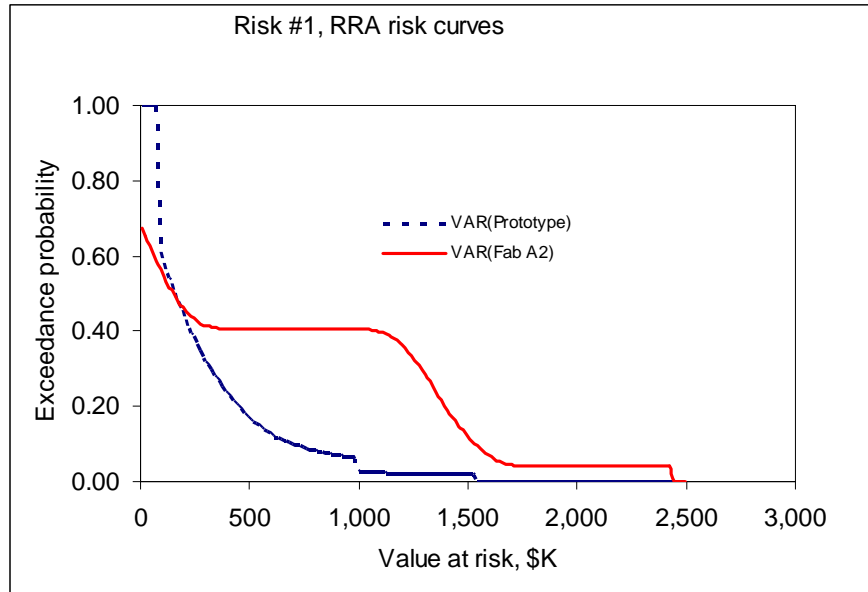
For any given value on the x-axis, the risk curve that corresponds to the lowest exceedance probability represents the lower risk. Figure 2b illustrates that the prototype risk curve is significantly lower than the fabrication risk curve and, thus, has less risk. In this hypothetical but realistic situation, the investment of \$100K for building a prototype provides a significant return on the investment as measured by the significant risk reduction. To be more precise, the prototype RRA presents a lower cost of risk mitigation for all values greater than \$200K. For the manager trying to decide if it is worthwhile to invest in the prototype option, the answer is to invest as long as the anticipated benefits from the prototype (whether it be cost savings, time savings, information, etc.) exceed \$200K.



NOTE: Given the different scales, the two PDFs are shown separately for greater visibility.

**Figure 2a. Probability Distributions Corresponding to the Two RRA Options for Risk #1**



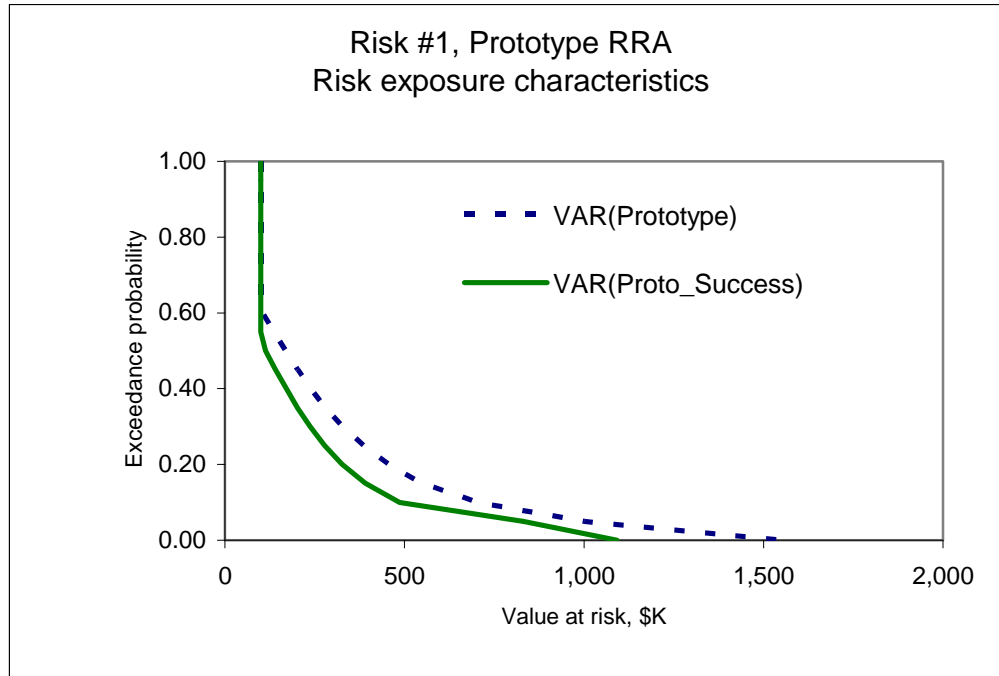


**Figure 2b. Risk Curves for the Two RRA Options for Risk #1**

## The Dynamic Character of Risk Response Actions

As a project progresses, its risk picture is dynamic. The sources and consequences of risks continue to evolve and change over time. As more information is obtained about a particular risk, the RRA options might change; thus, it is necessary to constantly monitor risk. In general, at any point in time there will be a mix of acceptable and unacceptable results. The performance of the RRAs should be monitored and controlled to ensure they are adequately mitigating risk. Concurrently, management reserves should be reviewed on a periodic basis and dynamically allocated where needed to ensure project success. The Lockheed Management Student Guide (1998, p. 33) states, “Risk management efforts that fail do so because the risk control actions did not keep up with a changing program situation.”

As discussed in the previous section, we use risk DTs to model the evolution of the potential RRAs. For example, Figure 3 depicts the Risk #1 risk curves at the start of implementation of the “Prototype” RRA and after the successful demonstration of the prototype. The latter risk curve moves to the left of the original risk curve and is narrower, which reflects a reduced risk. These two risk curves represent the value of the unmitigated risk exposure at two different points in time and, thereby, provide a metric for the risk exposure characteristics. This information is essential if analysts are to track the value of the residual exposure versus the value or cost of the expended RRAs and modify the RRAs as needed to ensure mission success. Note that if the risk curve moves to the right of the original risk curve, it means that risk exposure is increasing, and RRAs need to be re-evaluated.



**Figure 3. Risk Exposure Characteristics for Risk #1 with Development of a Prototype for Risk Mitigation at the Start and after Successful Demonstration**

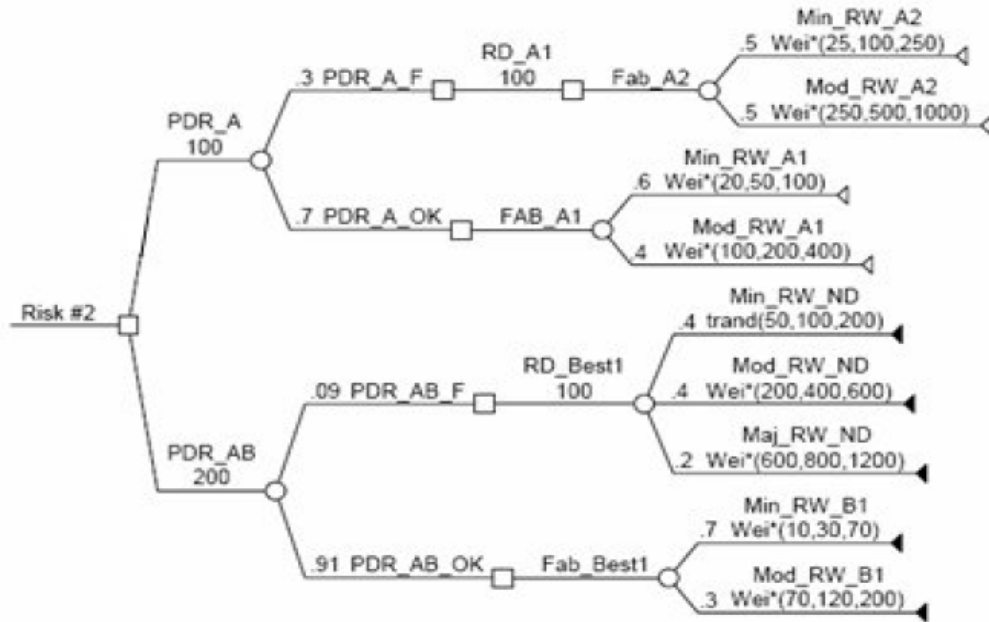
### Application to a Project with Multiple Risks

Now consider the hypothetical project with the following three independent risks: Risk #1 depicted in Figure 1; Risks #2 and #3 depicted in Figure 4a and 4b, respectively. It is both rich and simple enough to illustrate: (1) several diverse RRAs and their analysis, (2) the dynamic nature of the risk picture, and (3) the monitoring of individual risks and allocation of management reserves. The approach readily extends to dependent risks using different probability and outcome values that reflect causality effects among the risks.

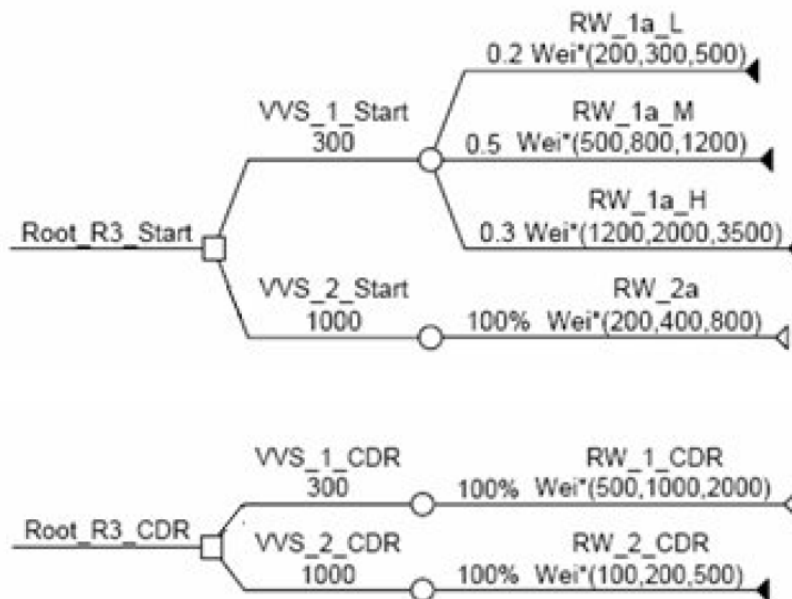
Figure 4a may be thought of as the prime contractor subcontracting the engineering and fabrication of a complex module. The prime is considering the following two options: (1) subcontract to a single contractor A, denoted by the branch PDR\_A associated with the initial node; (2) carrying two subcontractors and selecting the best one for fabrication at the Preliminary Design Review (PDR). The labeling is somewhat cumbersome because each branch needs to be uniquely identified. The PDR\_A sequence represents the decision to proceed with a single contractor. The PDR\_AB sequence represents the decision to proceed with two contractors and, at PDR, to select the best one for manufacturing. By selecting two different contractors with different offerings, the prime significantly reduces the probability of PDR failure. RW represents the cost associated with rework; it is modeled with a three-parameter Weibull distribution specified in terms of the 90<sup>th</sup>, 50<sup>th</sup>, and 10<sup>th</sup> percentiles provided by SMEs or historical data.

Figure 4b may be thought of a prime contractor who considers two different Verification and Validation (V&V) strategies as a means for risk reduction. The branch VVS\_1\_(Start or CDR) represents the use of the standard approach with planned expenditures of \$300K. The branch VVS\_2\_(Start or CDR) represents the use of a more

thorough V&V strategy with greater use of simulation and planned expenditure of \$1,000K. The branch RW\_1\_(PDR or CDR) represents the rework following the PDR and CDR, respectively. The rework is assumed to be inversely related to the V&V effort, and it is modeled with a three-parameter Weibull distribution specified in terms of the 90<sup>th</sup>, 50<sup>th</sup>, and 10<sup>th</sup> percentiles provided by SMEs or historical data.



**Figure 4a. Generalized Decision Tree for Risk #2 and Two Initial Candidate Risk Response Actions**



NOTE: The start (or PDR) and CDR periods are shown separately to simplify the representation of the sequence of events.

### **Figure 4b. Generalized Decision Tree for Risk #3 and Two Initial Candidate Risk Response Actions**

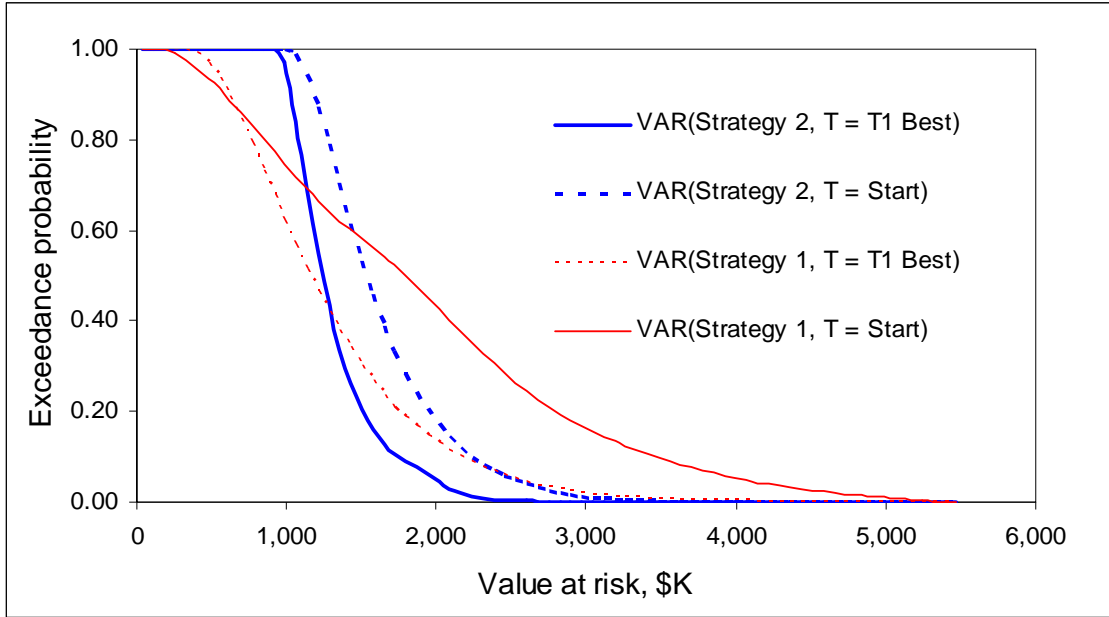
Given the above illustrative project—with three risks each with two potential RRAs—there are eight possible initial Total Project RRAs (TPRRA). As previously discussed, the risk picture is dynamic and gets quite complex as through time. Consider Risk #1 with development of a prototype as a risk reduction option. The prototype may fail or succeed, and the fabrication of the final module may fail or succeed. The full representation of the set of all possible outcomes for even this project is overwhelming and beyond the scope of a symposium paper. We, therefore, limit ourselves to reporting an interesting subset of the complete analysis as follows:

1. We consider only two of the eight TPRRAS.
  - a. Strategy 1. Use of the lowest cost-mitigation option for each risk, which is equivalent to proceeding as normal—i.e., no specific RRA for any of the three risks. This is the approach that a risk-seeker project manager would favor.
  - b. Strategy 2. Use the most effective RRA for each risk. This corresponds to: (1) developing a prototype for Risk #1, (2) proceeding with two contractors for Risk #2, and (3) implementing a more thorough V&V effort for Risk #3. This is the approach that a risk-averse project manager would favor.
2. For each strategy, we assume the best possible outcomes for the probabilistic nodes through time T1: the Risk #1 prototype and the Risk #2 review PDR\_AB succeed. Risk #3 has no gates; the risk reduction is directly accounted in the magnitude of the rework. Figure 5 compares the initial and residual risks under the two strategies.
3. For each strategy, we assume the worst outcomes for the probabilistic nodes through time T1: the Risk #1 prototype and the Risk #2 review PDR\_AB fail. Risk #3 has no gates; the risk reduction is directly accounted in the magnitude of the rework. Figure 6 compares the initial and residual risks under the two strategies.
4. For convenience, we also report the 50<sup>th</sup>, 80<sup>th</sup>, and mean values for the aggregated risks and individuals risks for strategies 1 and 2 in Tables 1 and 2, respectively.

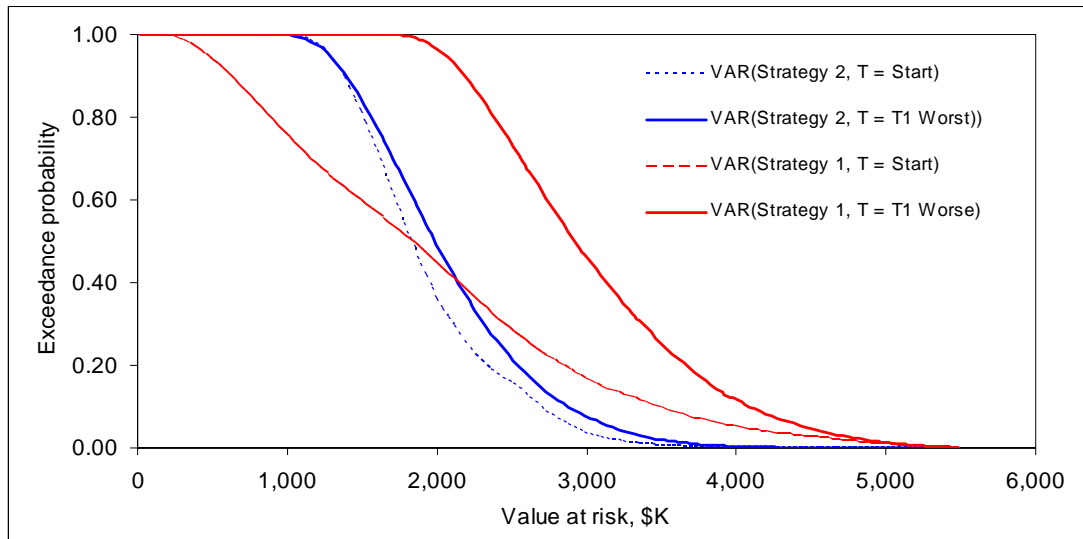
### Useful Information about Risk

We now make a few brief observations. By plotting the risk curves over time for each strategy, we can see from Figure 5 that if the best outcome is realized, both strategies reduce risk (as seen by the T1 curves moving left and becoming more vertical than the start curves over most of the range of analysis). Likewise, we see that if the worst outcome prevails as shown in Figure 6, then both strategies actually increase the cost risk exposure of the project. Graphing risk curves over time thus provides a metric to measure the success of risk mitigation efforts.





**Figure 5. Risk Exposure Characteristics for a Risk-seeking Strategy (Strategy 1) and a Risk-averse Strategy (Strategy 2), Assuming Good Luck Prevails on the Project**

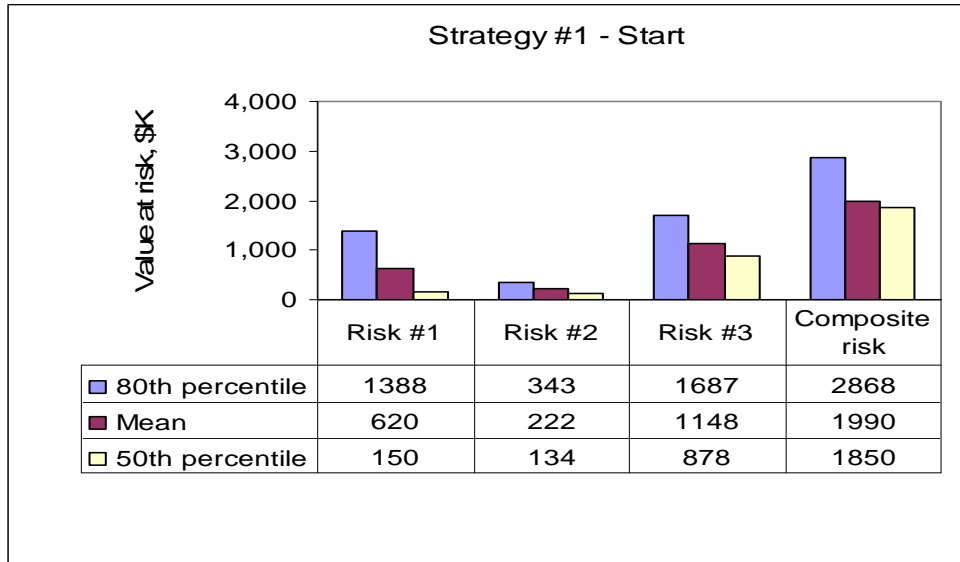


**Figure 6. Risk Exposure Characteristics for a Risk-seeking Strategy (Strategy 1) and a Risk-averse Strategy (Strategy 2), Assuming Murphy's Law Prevails on the Project**

But the graphs provide even more information. They allow us to consider the risk mitigation qualities of each strategy and to quantify our risk exposure. This information can be used to choose between the two strategies. Note that under the best-case scenario (Figure 5), at the start of the project, Strategy 1 offers a lower risk exposure below \$1,500K, while Strategy 2 offers a lower risk exposure above that value. Both strategies are equal in terms of exceedance probability (60 %) at the “breakeven” point of \$1,500K. What do we gain by extending the analysis to time T1? We see that the “breakeven” point is lower (\$1,200K), and the risk at that point is also lower (40%). So, which one is the best choice? If we were optimists and certain that the best outcome would be realized, we could make a choice based on the expected benefits. As long as the expected benefits of the RRA are greater than \$1,200, we would choose Strategy 2. But of course, we have no such assurance, so let's examine the worst-case scenario.

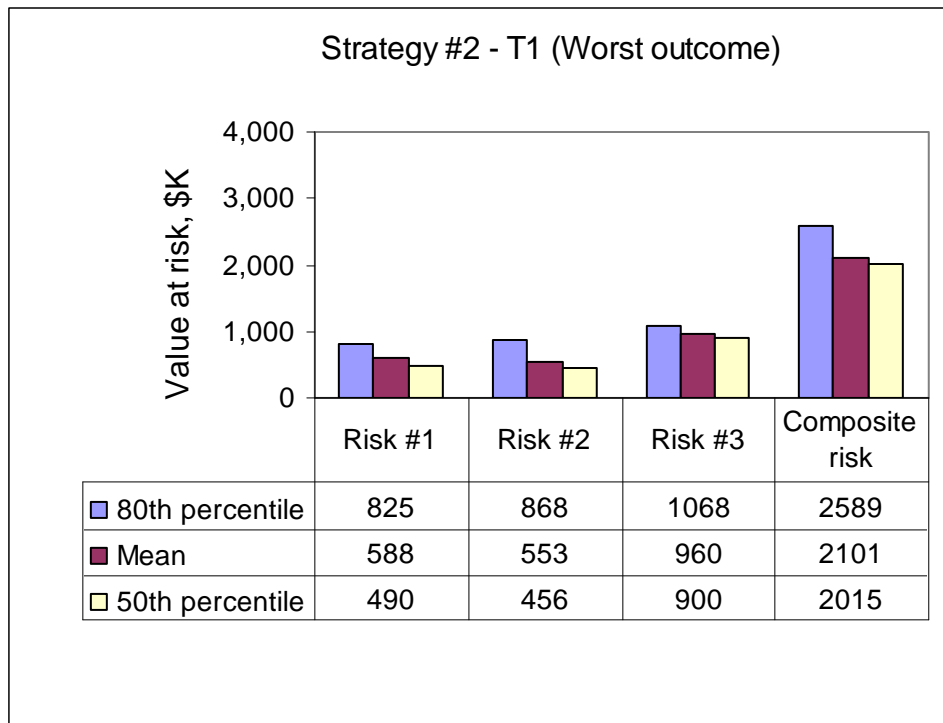
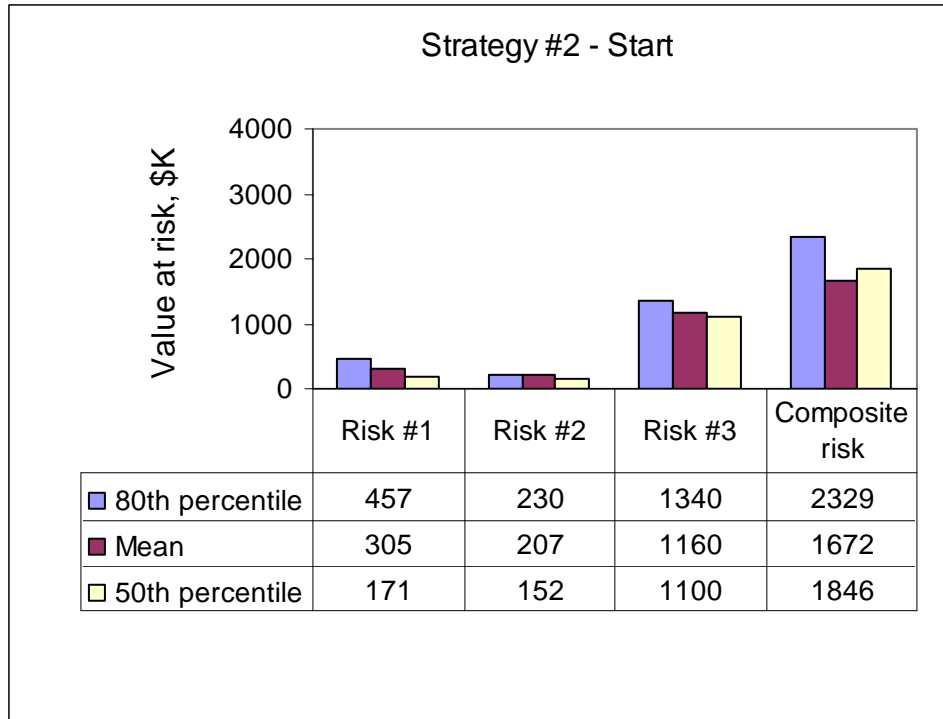
Figure 6 shows the results of implementing each strategy over time assuming the worst outcome (Murphy's Law). As expected, the risk-seeking Strategy 1 significantly increases our cost risk exposure when things go bad, but the more conservative Strategy 2 is much less sensitive to bad outcomes. In fact, at T1, Strategy 2 dominates Strategy 1—meaning it has a lower risk for any value. If we were pessimists, our choice would be simple: Strategy 2 is especially effective in providing insurance against the worst outcomes.

Which strategy is chosen depends on the decision-maker's risk aversion. Is he/she an optimist or a pessimist? In either case, if the expected benefits of risk mitigation exceed \$1,200K, Strategy 2 is the best choice. We believe examining risk information in this way provides useful insight and helps project managers make better choices.



**Table 1. Strategy 1 Risk Characteristics at Start and at T1, Assuming that Murphy's Law Prevails on the Project**





**Table 2. Strategy 2 Risk Characteristics at Start and at T1, Assuming that Murphy's Law Prevails on the Project**

Tables 1 and 2 suggest that the use of mean values is not necessarily a cautious approach for planning project contingency.



## Conclusions

We have presented a method for evaluating and tracking project-specific risks at the microscopic level. This type of analysis, as opposed to the macroscopic-level risk analysis, is essential for risk management. While the macro level provides some information about total cost risk, the micro level allows the project manager to plan and control risk response actions that influence total cost risk.

We demonstrated the use of risk decision trees to model the evolution of the potential RRAs, and we used risk curves to evaluate the risk. We believe risk curves are better than the expected-value results usually given by traditional DT analysis because they contain all the risk information both in terms of probabilities and value at risk. This thorough approach allows management to consider what they mean by “acceptable” risk and explicitly models the tradeoff between risk and benefits of any given RRA.

We recommend the use of risk curves to evaluate the performance of RRA and to track their performance over time. If the RRA is working (at reducing risk), we should see the corresponding risk curve move to the left and/or become more vertical. This tracking over time is key to understanding the dynamic nature of risk management and can reveal necessary changes in strategy.

Risk curves derived from Monte Carlo simulation on DTs are particularly useful when analysts are comparing different risk-mitigation strategies. The “breakeven” points help the risk manager understand the conditions under which each strategy is most appropriate. Combined with scenario analysis, it offers an opportunity to make cost-benefit tradeoffs among strategies.

We think that these results provide the detailed information that program managers need and want when they face hard decisions on programs. There is a cost for this type of analysis, but it is small considering the potential benefits. The proposed approach is both practical and mathematically valid and can be implemented using commercially available tools such as Crystal Ball and @Risk. The challenge is to start implementing these more refined cost models and risk management practices.

## List of References

- Arena, M.V., Blickstein, I., Younossi, O., & Grammich, C.A. (2006). *Why has the cost of Navy ships risen?* Report prepared for US Navy. Santa Monica, CA: RAND.
- Arena, M.V., Leonard, R.S., Murray, S.E., & Younossi, O. (2006). *Historical cost growth of completed weapon system programs.* Report prepared for US Air Force. Santa Monica, CA: RAND.
- Burgess, R.B. (2007, July). Clout: Navy takes steps to gain better control of acquisition process. *Seapower*, 40-44. Retrieved April 22, 2008, from <http://www.seapower-digital.com/seapower/200707/?pg=46>
- Hollmann, J.K. (2007). The Monte-Carlo challenge: A better approach. In *Proceedings of 2007 AACE International Transactions* (Risk .03.01-03.07). Morgantown, WV: AACE.
- Kujawski, E. (2002). Selection of technical risk responses for efficient contingencies. *Systems Engineering*, 5(3), 194-212.
- Kujawski, E., & Miller, G.A. (2007). Quantitative risk-based analysis for military counterterrorism systems. *Systems Engineering*, 10(4), 273-289.



OUSD(AT&L). (2006, August). Systems and software engineering, enterprise development. *Risk management guide for DoD acquisition* (6<sup>th</sup> ed). (Ver. 1.0). Retrieved April 12, 2008, from <https://acc.dau.mil/CommunityBrowser.aspx?id=108201>

Pennock, M.J., & Haimes, Y.Y. (2002). Principles and guidelines for project risk management. *Systems Engineering*, 5(2), 89-108.



# Using the Steel Vessel Material-cost Index to Mitigate Shipbuilder Risk

---

**Presenter: Edward G. Keating** is a senior economist at RAND specializing in applied and empirical issues in defense economics. He has worked on disparate research projects, including aircraft depot-level maintenance, replacement of aging aircraft, optimal contract design, outsourcing and privatization, and DoD working capital fund policies. He received a PhD in Economic Analysis and Policy from Stanford University.

Edward G. Keating  
RAND Corporation  
P.O. Box 2138  
Santa Monica, CA 90407-2138  
Phone: 310-393-0411, x6546  
Fax: 310-393-4818  
E-mail: [keating@rand.org](mailto:keating@rand.org)

**Author: Robert Murphy** retired as a member of the Senior Executive Service after a 33-year career in the US Navy's Nuclear Propulsion Program. He finished his career as the Director of Resource Management, responsible for budget, acquisition and logistic support for the Naval Nuclear Propulsion Program. Since retiring from public service, he has been consulting for commercial and government organizations regarding major system acquisitions.

**Author: John F. Schank** is a senior operations research analyst at RAND. He has been involved in a wide range of research issues, including shipbuilding acquisition and industrial base analyses, cost analyses, manpower, personnel, and training issues, and logistics. He holds a BS in Electrical Engineering from Drexel University and an MS in Operations Research from the University of Pennsylvania.

**Author: John Birkler** is a senior management system scientist at RAND. He is responsible for managing US Navy, US Coast Guard, and UK Ministry of Defence research projects. He holds a BS and MS in Physics and completed the UCLA Executive Program in Management in 1992. After completing his third Command tour, he retired from the Navy Reserve with the rank of Captain.

---

## Abstract

This paper describes how the US Navy structures fixed-price and fixed-price, incentive-fee shipbuilding contracts and how labor- and material-cost indexes can mitigate shipbuilder risk in either type of contract. The Navy frequently uses the Steel Vessel material-cost index, a Bureau of Labor Statistics-derived cost index based on the mix of materials in a typical commercial cargo ship constructed in the 1950s. The Steel Vessel Index has excessive weighting on iron and steel, thereby providing shipbuilders with a mismatch between their actual and the Index-assumed material-cost structure. We recommend the Navy use a material-cost index with more up-to-date weightings.

## Introduction

The Navy wants to provide its shipbuilders with appropriate incentives to produce militarily effective vessels at minimum cost to the Navy.



Fixed-price contracts provide incentive to a shipbuilder to produce at minimum cost. After contract award, cost savings the shipbuilder can implement flow directly to the shipbuilder, resulting in higher profit. Conversely, cost overruns are borne by the shipbuilder, resulting in lower-than-anticipated profits.

Fixed-price contracting becomes problematic, however, when a shipbuilder is forced to bear risk outside of its control. For instance, ship construction requires material inputs like steel, wire, cable, and myriad others. If the global prices of these commodities rise, a fixed-price shipbuilder will have lower profits (or increased losses) external to the shipbuilder's efforts.

Ultimately, the Navy can induce a shipbuilder to agree to any arrangement, including having the shipbuilder bear material-cost risk, by offering the shipbuilder a high enough price. But it is likely to be preferable, at least ex ante, for the Navy to dissipate risk external to its shipbuilder in order to pay less for the systems the Navy needs.

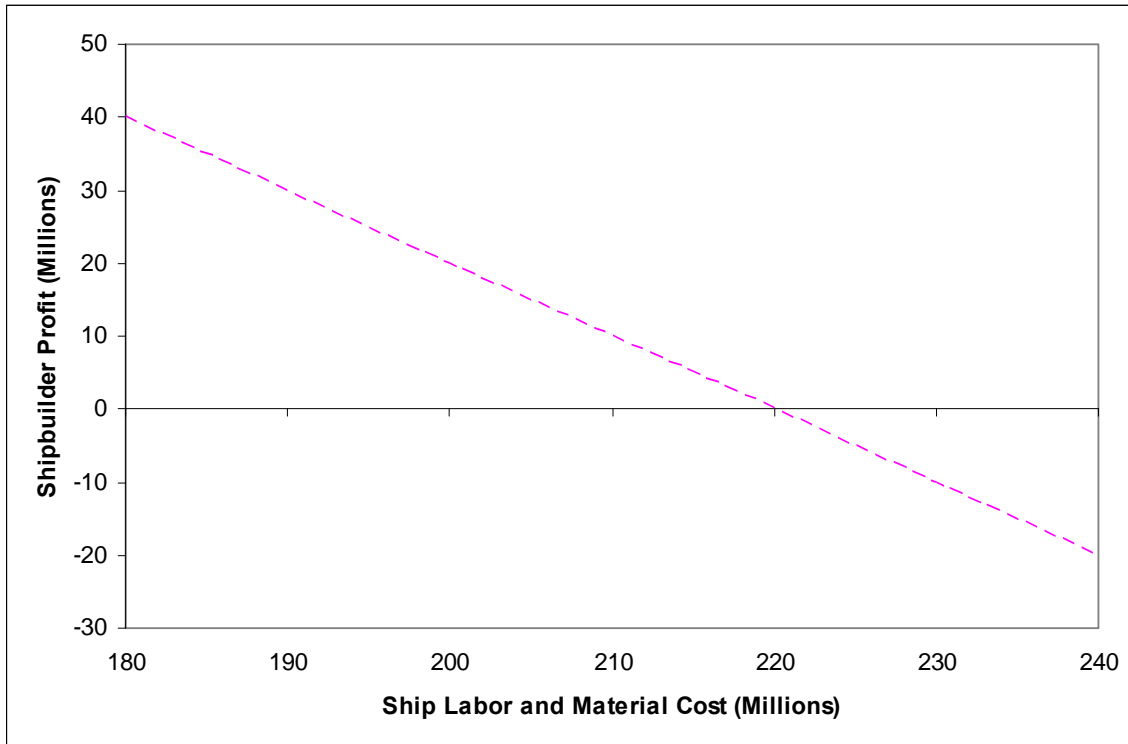
Conversely, the Navy should not fully immunize a shipbuilder against risks within the shipbuilder's control, e.g., if the shipbuilder's own failures cause a cost overrun. In such a case, the shipbuilder should incur at least a portion of the loss. Of course, it can sometimes be difficult to distinguish problems within a shipbuilder's control versus those caused or exacerbated by Navy decisions (e.g., changing requirements) versus those related to external issues (e.g., the rising global price of steel). The Navy uses labor- and material-cost indexes to attempt to correct for several significant cost risks outside its shipbuilders' control. The indexes reflect industry- or economy-wide costs, not the costs of the specific shipbuilder.

## How the Navy uses Labor- and Material-cost Indexes

In this section of the paper, we present illustrative examples of how the Navy uses labor- and material-cost indexes. We start with a highly oversimplified example of a fixed-price contract to illustrate the basic intuition. Subsequently, we turn to an enhanced (though still less complex than reality) example of a contract more in accord with current Navy practices. This latter example is a Fixed-Price, Incentive Fee (FPIF) contract. An FPIF contract is no longer a "pure" fixed-price contract in that it requires the Navy and the shipbuilder to share cost changes from the negotiated level with incentives and disincentives for underruns and overruns (whereas a textbook fixed-price contract would not). The shipbuilder's actual costs are considered in an FPIF contract; they are not in a fixed-price contract.

**A Very Simple Example.** Let us suppose the Navy signs a fixed-price contract for a \$220 million ship on January 1, 2007, with completion scheduled for January 1, 2010. If \$100 million of the payment is to cover expected labor costs, another \$100 million is to cover expected material costs, and the final \$20 million is intended to be contractor profit. Of course, the actual cost the shipbuilder incurs determines the shipbuilder's profit. Figure 1 shows the shipbuilder's profit as a function of the actual labor and material cost of the ship. Increasing costs reduce shipbuilder profits dollar-per-dollar.





**Figure 1. Shipbuilder Profit as a Function of Labor and Material Cost with a Fixed-price Contract**

Adding material-cost indexes to this fixed-price contract would protect the shipbuilder against exogenous cost risk.

Let us also suppose, during the period 2007-2010, the external labor-cost index designated in the contract goes up 5%, while the designated material-cost index goes up 20%. Then the Navy's actual payment to its shipbuilder would be \$245 million (\$105 million for labor, \$120 million for materials, \$20 million in intended or target profits—assuming the profit level does not increase with the indexes). The shipbuilder's actual profit would then go up and down based on whether their actual cost growth was above or below the indexes'. Obviously, it is of central importance that the cost indexes are agreed upon up front.

If, on the other hand, the labor-cost index had risen 5% while the material-cost index had fallen 10%, the Navy's payment to the shipbuilder would be \$215 million (\$105 million in labor, \$90 million in materials, \$20 million for target profit). Again, actual profit would depend on whether the shipbuilder's total costs had fallen less than or more than the indexes suggested.

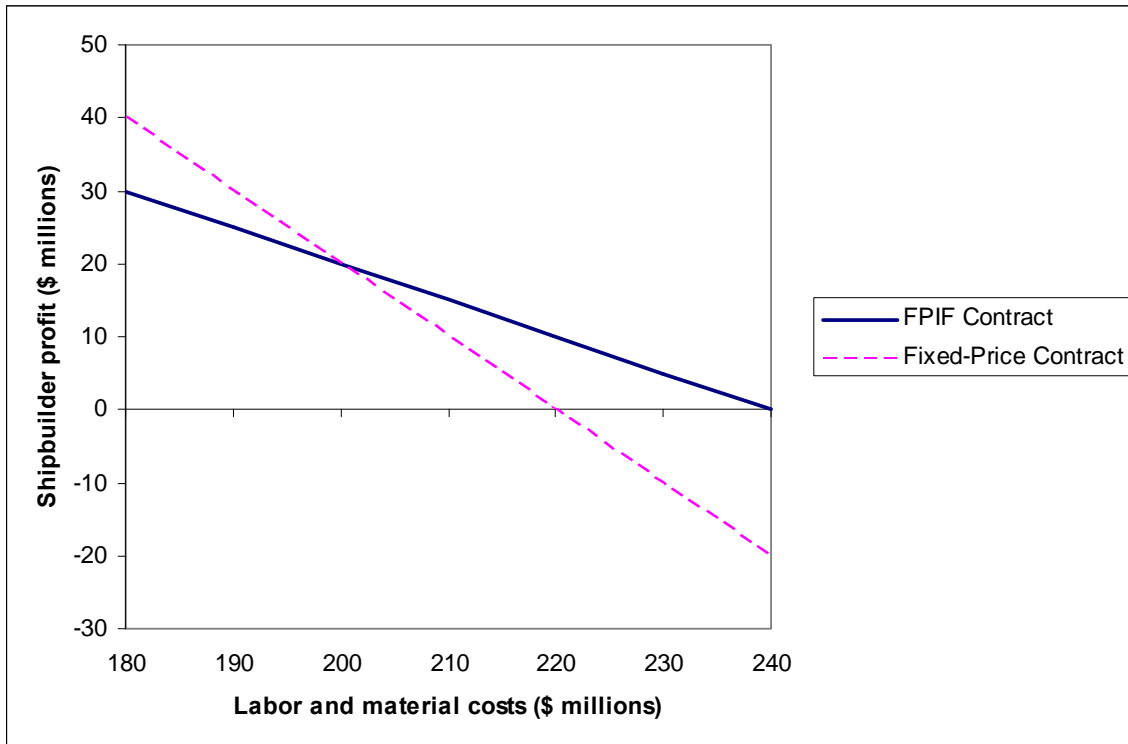
Both this example and the one that follows are over-simplified. Both examples assume all labor is incurred and material purchased on the last day of the contract. If one alternatively assumes the postulated inflation, labor hours, and material purchases occur uniformly between 2007 and 2010, the average inflation rate would be half as large. In reality, material purchases peak before labor hours are incurred, so there are two cost timing distributions to account for. Actual Navy escalation clauses calculate these effects on actual costs incurred monthly. The Appendix discusses such an enhancement.

**A More Realistic Example.** The Navy does not generally write shipbuilding contracts that are as simple as the preceding example. Instead, the norm is to use FPIF contracts with “compensation adjustment clauses” or “escalation provisions” to:

- Ensure the incentive provision operates independent of outside economic forces that impact shipbuilder costs.
- Keep the shipbuilder from including contingent amounts in its price to cover economic uncertainty associated with external cost pressure.

In this approach, subsequent changes in specified cost indexes result in payments (or refunds) tied to the shipbuilder’s actual labor and material costs incurred. Notice this approach is no longer a “pure” fixed-price contract; shipbuilders’ actual costs are considered. FPIF contracts actually operate as cost-type incentive contracts within a certain range of costs.

We can consider a similar example as above with the Navy signing a contract for a ship on January 1, 2007, with completion scheduled for January 1, 2010. It is anticipated \$100 million will be spent on labor and another \$100 million on material. Let us suppose the Navy also agrees to a 10% target profit rate and a sharing ratio of 50/50 for increases or decreases in cost. Figure 2 illustrates shipbuilder profit under this FPIF contract versus the preceding fixed-price case (prior to consideration of cost-index issues). Since this FPIF contract has cost-change sharing between the Navy and the shipbuilder, the FPIF line is flatter.



**Figure 2. Shipbuilder Profit as a Function of Labor And Material Cost with Different Contract Structures**



As above, it would enhance realism to include labor- and material-cost indexes into this contract.

Let us suppose, during the period 2007-2010, the labor-cost index designated in the contract goes up 5%, while the designated material-cost index is up 20%. We assume base period labor and material costs of \$100 million each. If the shipbuilder's actual labor cost was \$105 million, the Navy would pay a compensation adjustment of \$5 million ( $(0.05 \text{ divided by } 1.05) \text{ multiplied by } \$105 \text{ million}$ ).<sup>10</sup> If actual material costs turned out to be \$115 million, the Navy would make a material compensation adjustment of \$19.17 million ( $(0.20 \text{ divided by } 1.20) \text{ multiplied by } \$115 \text{ million}$ ). The "de-escalated base cost" of the ship would be \$195.83 million (the actual \$105 million plus \$115 million less the compensation adjustments of \$5 million and \$19.17 million). The \$4.17 million decrease between the initial base cost and the de-escalated base cost would translate into a \$2.08 million increase in profit for the shipbuilder given the assumed 50/50 cost change-sharing ratio. The shipbuilder is rewarded because actual material costs did not rise as rapidly (+15%) as the material-cost index (+20%).

The Navy's actual payment to the shipbuilder would be comprised of \$195.83 million in de-escalated base cost, \$5 million in labor escalation payments, \$19.17 million in material escalation payments, \$20 million in target profit, plus \$2.08 million in incentive profit—totaling \$242.08 million. Shipbuilder profit would be \$22.08 million.

By contrast, holding the shipbuilder's incurred costs the same as above, suppose the labor-cost index had again risen 5% while the material-cost index fell 10%. The labor compensation adjustment would remain \$5 million ( $(0.05 \text{ divided by } 1.05) \text{ multiplied by } \$105 \text{ million}$ ). The material compensation adjustment would now be a reimbursement from the shipbuilder of \$12.78 million ( $(-0.10 \text{ divided by } 0.90) \text{ multiplied by } \$115 \text{ million}$ ). The "de-escalated base cost" of the ship would be \$227.78 million (\$105 million plus \$115 million minus \$5 million plus \$12.78 million). This increase in the de-escalated base cost would result in a \$13.89 million profit penalty for the shipbuilder (50% of the difference between \$227.78 million and \$200 million). Then, the Navy would pay the shipbuilder \$226.11 million (\$227.78 million in de-escalated base cost plus \$5 million in labor escalation payments less a \$12.78 million material de-escalation reimbursement plus \$20 million in target profit less a \$13.89 million incentive profit penalty). The shipbuilder profit would be \$6.11 million.

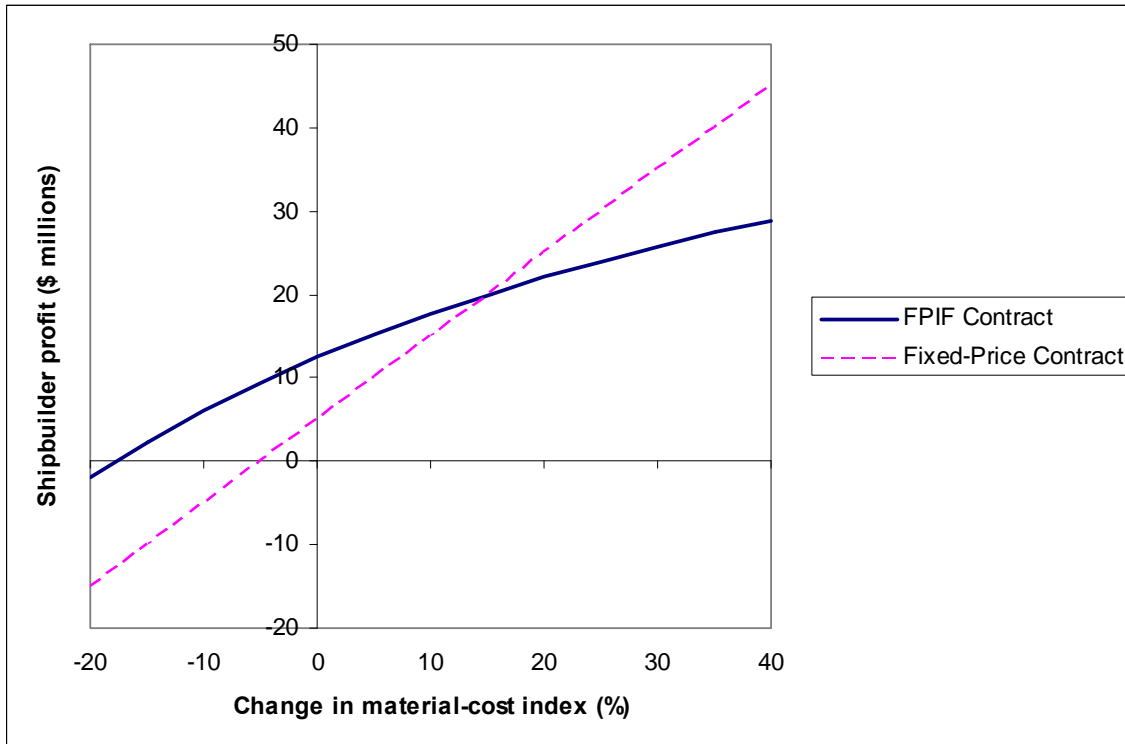
As in the "Very Simple Example," we have ignored realistic timing issues, e.g., the fact that median material cost probably precedes the median labor cost and that neither cost is incurred, on average, in 2010. The Appendix discusses the effects of incorporating labor and material-cost time-phasing.

Figure 3 summarizes the differential results of these examples, holding fixed that the labor-cost index increased 5%, while realized shipbuilder costs were \$115 million for material and \$105 million for labor. Not surprisingly, when the shipbuilder spends more on material than included in the original price while the overall material market has falling prices, the cost disincentive built into the contract reduces the Navy's payment and, hence, the shipbuilder's profit. (The shipbuilder would have performed very poorly if it paid \$115 million for material while material prices were, on average, falling.)

---

<sup>10</sup> For expositional simplicity, we are assuming actual labor costs match the increase in the labor-cost index, allowing us to concentrate on material-cost issues.





**Figure 3. Shipbuilder Profits Are Greater When the Material-cost Index Rises More, Realized Costs Held Constant**

The Fixed-price Contract line and the FPIF Contract curve cross at a 15% increase in the material-cost index. We have assumed the shipbuilder’s actual material-cost increase was 15% or \$15 million. If the shipbuilder can keep its actual material-cost growth below the index level, its reward is greater in the fixed-price case, in which there is no cost-change sharing with the Navy. Conversely, the shipbuilder’s profit does not diminish as rapidly if its actual material costs increase more than the Material-cost Index with the FPIF contract’s cost sharing.

If the shipbuilder’s skillful management kept ship costs from rising as much as similar costs in the general economy, greater profits are an appropriate reward. However, if greater profits result from escalation payments calculated by an external price index that does not accurately reflect what the shipbuilder purchases, then greater profit is not warranted. Conversely, it would be unfair to penalize a shipbuilder if an inappropriate cost index declines or increases less than the shipbuilder’s actual cost environment.

### The Steel Vessel Index

A longtime material-cost index in Navy shipbuilding is the “Steel Vessel Index.” Based on an estimate by the Maritime Administration of the mix of materials in a typical commercial cargo ship constructed in the 1950s (GAO, 1972), it is a weighted average of three Bureau of Labor Statistics (BLS) producer price indexes (45% Iron & Steel, 40% General Purpose Machinery and Equipment, and 15% Electrical Machinery and Equipment). If, for instance, the Iron & Steel price index increased 3% in a year, the General Purpose

Machinery index increased 2%, and the Electrical Machinery index fell 1%, the Steel Vessel Index would increase 2% ( $0.45*0.03+0.4*0.02-0.15*0.01$ ).<sup>11</sup>

One criticism of the Steel Vessel cost index is that it does not accurately cover the materials used in building a modern ship.<sup>12</sup> No modern US Navy ship, for instance, has 45% of its material costs in Iron & Steel. To combat this shortcoming, the DDG-51<sup>13</sup> and T-AKE<sup>14</sup> programs created their own material-cost indexes, using different weights on the same three underlying BLS indexes (DDG-51: 20% Iron & Steel, 43% General Purpose Machinery, 37% Electrical Machinery; T-AKE: 10% Iron & Steel, 60% General Purpose Machinery, 30% Electrical Machinery). See Pfeiffer (2006). In the preceding paragraph's example, whereas the Steel Vessel Index would increase 2%, the DDG-51 index would increase 1.09% ( $0.2*0.03+0.43*0.02-0.37*0.01$ ), and the T-AKE index would increase 1.2% ( $0.1*0.03+0.6*0.02-0.3*0.01$ ).

There is an additional challenge with any of these indexes: even if one correctly identified the mix of materials that went into the ship, the materials would be purchased at different stages of ship construction. Steel, for instance, is required early in the construction process. Conversely, combat systems and electrical equipment (perhaps more akin to General Purpose or Electrical Machinery) are not delivered to the shipyard and, consequently, do not become incurred costs until much later in construction. Time-phasing the mix of an overall material-cost index could provide greater fidelity. However, it is unlikely any material-cost index will completely dissipate a shipbuilder's exogenous material-cost risk.

Historically, BLS's Iron & Steel price index has been much more volatile than the General Purpose Machinery or Electrical Machinery indexes. Figure 4 displays these indexes' quarterly returns (with a positive "return" if the cost index value went up, negative if it fell) between the second quarter of 1947<sup>15</sup> and the fourth quarter of 2006. We also display the quarterly change in the Bureau of Economic Analysis' (BEA) Gross Domestic Product (GDP) price deflator, a measure of overall inflation in the economy.

---

<sup>11</sup>There does not appear to be an Air Force analog to the Steel Vessel Index. Air Force procurement contracts may include BLS-based labor- or material-cost indexing, but this is done on a case-by-case basis at the discretion of the program office. There is no standard aircraft material-cost index. An aircraft's construction duration is typically much briefer than that of a ship, so inflation issues are less prominent.

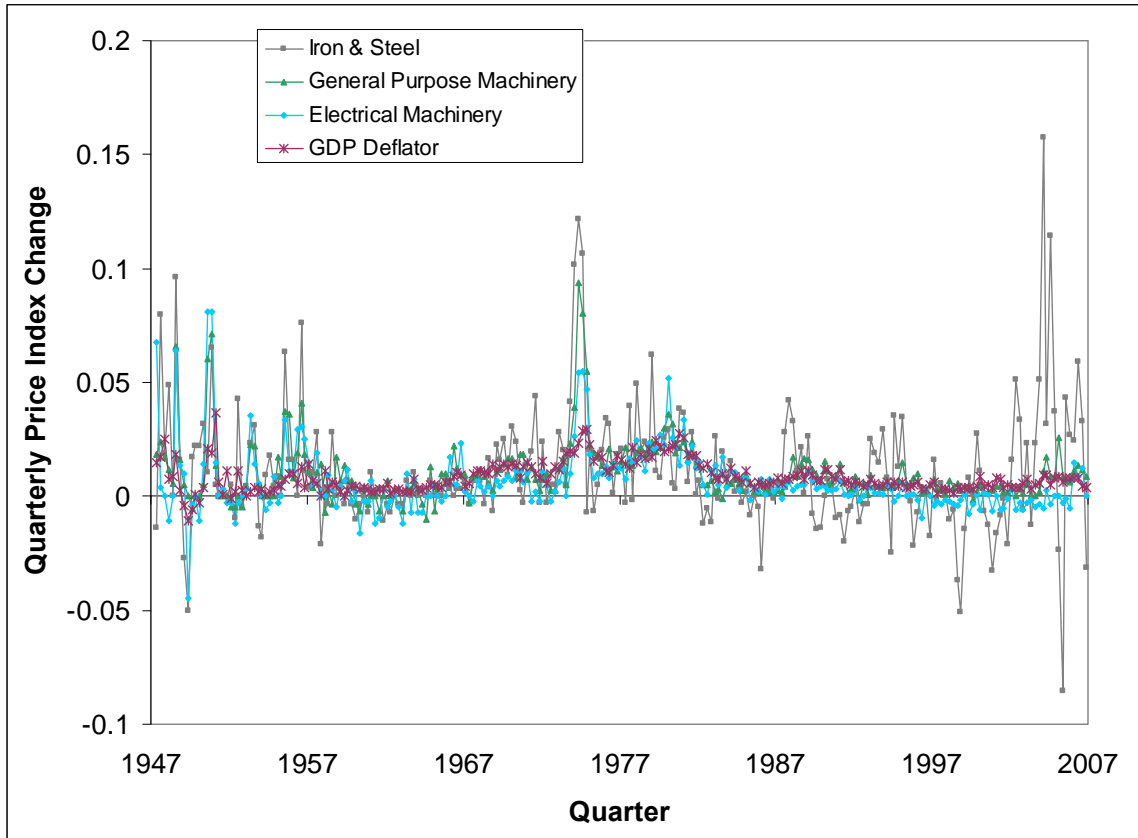
<sup>12</sup>Indeed, criticism of the Steel Vessel Index pre-dates what we might term "modern" ships. Geismar (1975) suggests the Steel Vessel Index was ill-suited to the DD963, Spruance Class destroyer, and the LHA, Marine amphibious assault ship—two 1970s-era ship programs. (Both of these ships were very late in delivering, implying inflation issues proved to be more important than would have been the case had their production been more timely.)

<sup>13</sup>The DDG-51, the *USS Arleigh Burke*, is a destroyer commissioned on July 4, 1991. The moniker "DDG-51" refers to the class of destroyers of which the *USS Arleigh Burke* was the first (US Navy, 2006).

<sup>14</sup>"T-AKE" refers to the *Lewis and Clark* class of dry cargo/ammunition ships. The *USNS Lewis and Clark*, the *USNS Sacagawea*, and the *USNS Alan Shepard* have been delivered to the Navy; the *USNS Richard Byrd* is under construction (US Navy, 2007; Bigelow, 2007).

<sup>15</sup>Monthly BLS data on these cost indexes are available back to January 1947. However, the BEA GDP deflator data are only available quarterly, so we aggregated the BLS data to the quarter level.

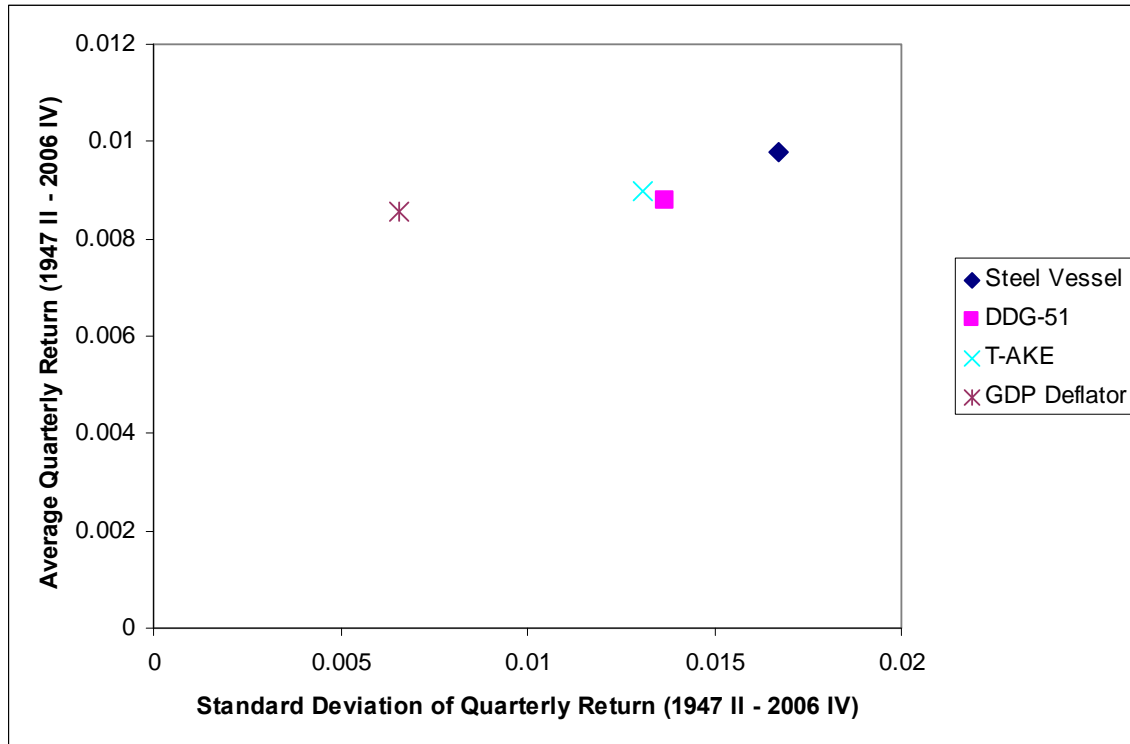




**Figure 4. Quarterly Changes in Different Cost Indexes**  
(US DoL, BLS, n.d.; US DoC, BEA, n.d.)

Naturally, given the Steel Vessel Index's greater relative weighting of the Iron & Steel price index, it has been more volatile than the DDG-51 or T-AKE indexes. In Figure 5, we plot the standard deviation in the quarterly return and the mean quarterly return for the three ship material-cost indexes and the GDP deflator between the second quarter of 1947 and the fourth quarter of 2006.<sup>16</sup> The Steel Vessel Index has the greatest standard deviation in its quarterly return.

<sup>16</sup>None of the three ship material-cost indexes existed in 1947. But, we can use BLS data to retrospectively compute how they would have evolved.



**Figure 5. Quarterly Standard Deviation and Average Return of Different Material-cost Indexes**

What Figure 5 does not show is how closely correlated any of these indexes is with the actual cost variability a shipbuilder experiences. The best cost index is the one that minimizes a shipbuilder’s exogenous risk and, therefore, minimizes the risk premium the Navy must pay the shipbuilder. We know, however, the Steel Vessel Index over-represents iron and steel costs in current naval warship contracts.

The fact the Steel Vessel Index has had a mean quarterly return greater than the other indexes and greater than the economy-wide inflation rate is not *prima facie* bad news for the Navy. In a competitive setting, a shipbuilder will submit a lower bid up front if it expects super-normal escalation. Therefore, the Navy’s expected costs are not, in equilibrium, affected by the Index’s mean.

What is more problematic is the known mismatch between the Steel Vessel Index’s composition and a shipbuilder’s material-cost structure. The shipbuilder bears a risk, for instance, that the prices of iron and steel may tumble while the shipbuilder’s do not. A risk-averse shipbuilder will require a premium to bear this mismatch-driven risk.

This mismatch-driven risk could be reduced if the shipbuilder could take a short position on steel futures, i.e., hedge against the risk steel prices will fall. Currently, however, there is no functioning steel futures market.<sup>17</sup>

<sup>17</sup>There is an ongoing debate as to the feasibility and desirability of a steel futures market. See, for instance, Anderson (2006).

Paradoxically, if the shipbuilder locked in its steel input prices through a long-term, fixed-price contract with a steel mill, the shipbuilder's mismatch-driven risk could be exacerbated, not mitigated. If future steel prices fell, the shipbuilder would receive no advantage on the cost side while receiving reduced revenue from the Navy.

We do not know the "right" material-cost index to use to minimize a shipbuilder's material-cost risk. We do know, however, the Steel Vessel Index is imperfect due to its over-representation of iron and steel. As shown in Figure 5, there is little difference between the DDG-51 and T-AKE approaches; their quarterly returns are positively correlated at the 0.985 level. (By contrast, the Steel Vessel index has a 0.936 correlation with the DDG-51 index and 0.873 with T-AKE.)

Of the three Navy material-cost indexes, T-AKE (0.655) and DDG-51 (0.636) are more highly correlated with the GDP deflator than is the Steel Vessel Index (0.538). The explanation for the Steel Vessel Index's relative lack of correlation with overall inflation in the economy is that the Iron & Steel cost index has a much lower correlation (0.360) with the GDP deflator than the General Purpose Machinery (0.634) and Electrical Machinery (0.609) cost indexes. So, a material-cost index that over-samples Iron & Steel moves away from representation of economy-wide costs.

The foremost argument in favor of the Steel Vessel Index is its familiarity and, consequently, the comfort some shipbuilders have with the Index. Almost everyone we met in the nautical construction industry knows of the Steel Vessel Index, and most have experience with contracts tied to it. The Steel Vessel Index is, perhaps, akin to the Dow Jones Industrial Average in that one would not invent it anew (or at least not with its current weightings), but its fame and tradition keep it in use.<sup>18</sup>

If shipbuilders are familiar and comfortable with the Index, the Navy and the government benefit, as this may imply shipbuilders can be paid less when the Index is in use. The best material-cost index minimizes the exogenous risk shipbuilders perceive they face so as to therefore minimize Navy ship acquisition costs. Unless one believes familiarity is extremely important, however, the manifest cost structure mismatch of the Steel Vessel Index suggests its usage does not minimize the Navy's expected costs.

## Conclusions

We do not think the Navy should use the Steel Vessel Index to adjust for material-cost changes in future shipbuilding contracts. The Steel Vessel Index clearly puts excessive weight on Iron & Steel relative to the materials actually used in constructing a modern ship. Usage of the Steel Vessel Index does not appropriately mitigate contractor material-cost

---

<sup>18</sup>Discussing an earlier version of this paper, Jim Jondrow of the Center for Naval Analyses raised the following analogy to the Navy's continued use of the Steel Vessel Index: let us suppose one owned a portfolio that mirrored the NASDAQ Composite Index, but one observed the Dow Jones Industrial Average (or vice versa). On March 10, 2000, the NASDAQ Composite Index closed at an all-time high of 5046, but then fell precipitously, ultimately hitting a bottom of 1114 on October 9, 2002. See "Nasdaq Composite" (n.d.). Meanwhile, the Dow Jones Industrial Average closed at 9929 on March 10, 2000, and at 7286 on October 9, 2002. See Yahoo! Finance (n.d.). The indexes were positively correlated with one another, but the magnitudes of the changes were sharply different.





risk. Indeed, from a shipbuilder's perspective, a new risk is created: the risk the prices of what the shipbuilder actually buys will rise faster than the price of steel.

The shortcomings of the Steel Vessel Index have been known for many years. The DDG-51 and T-AKE programs created their own material-cost indexes with lower weight on Iron & Steel. Their material-cost indexes, which empirically have been highly correlated with one another, are doubtlessly better indexes than the Steel Vessel Index, though they still appear to put too much weight on Iron & Steel (DDG-51: 20%, T-AKE: 10%).

We urge the Navy to develop a "Modern Vessel Index" that more appropriately represents the material used in constructing ships. Movement toward a better index would also be an opportunity to explore a time-phased material-cost index—e.g., reflect the fact shipbuilders typically buy keel steel early in production, with on-board electronics procured much later in the construction process. The more accurately a material-cost index captures a shipbuilder's external material-cost risk, the less the Navy may expect to pay its shipbuilders.

## List of References

- Anderson, M.W. (2006, September/October). Steel in your futures. *Forward Online: Global Perspective from MSCI*. Retrieved March 4, 2007, from <http://forward.msci.org/articles/0906steelfutures.cfm>
- Bigelow, B.V. (2007, August 24). NASSCO makes deal for more navy cargo ships. *San Diego Union-Tribune*. Retrieved August 24, 2007, from <http://www.signonsandiego.com/news/business/20070824-9999-1b24nassco.html>
- Geismar, D.D. (1975). *Composition of material price indices for naval ship contract escalation* (Master's Thesis). Monterey, CA: Naval Postgraduate School.
- Nasdaq Composite. (n.d.). Wikipedia. Retrieved July 4, 2007, from [http://en.wikipedia.org/wiki/Nasdaq\\_Composite](http://en.wikipedia.org/wiki/Nasdaq_Composite)
- Pfeiffer, L. (2006). Steel vessel material index slides.
- US Department of Commerce, Bureau of Economic Analysis. (n.d.) National economic accounts. Retrieved July 17, 2007, from <http://www.bea.gov/national/nipaweb/Index.asp>
- US Department of Labor, Bureau of Labor Statistics. (n.d.). BLS web site. Retrieved July 17, 2007, from <http://www.bls.gov/data/home.htm>
- US GAO. (1972). *Feasibility of constructing price indexes for weapon systems* (B-159896). Report to the Joint Economic Committee Congress of the United States. Retrieved June 17, 2007, from <http://archive.gao.gov/f0302/096606.pdf>
- US Navy. (2006). *United States Navy fact file: Destroyers—DDG*. Retrieved August 22, 2007, from [http://www.navy.mil/navydata/fact\\_display.asp?cid=4200&tid=900&ct=4](http://www.navy.mil/navydata/fact_display.asp?cid=4200&tid=900&ct=4)
- US Navy. (2007). *United States Navy fact file: Dry cargo/ammunition ships—T-AKE*. Retrieved August 22, 2007, from [http://www.navy.mil/navydata/fact\\_display.asp?cid=4400&tid=500&ct=4](http://www.navy.mil/navydata/fact_display.asp?cid=4400&tid=500&ct=4)
- Yahoo! Finance. (n.d.). *Dow Jones Industrial Average historical prices*. Retrieved July 4, 2007, from <http://finance.yahoo.com/q/hp?s=%5EDJI&a=02&b=10&c=2000&d=09&e=9&f=2002&g=d&z=66&y=0>

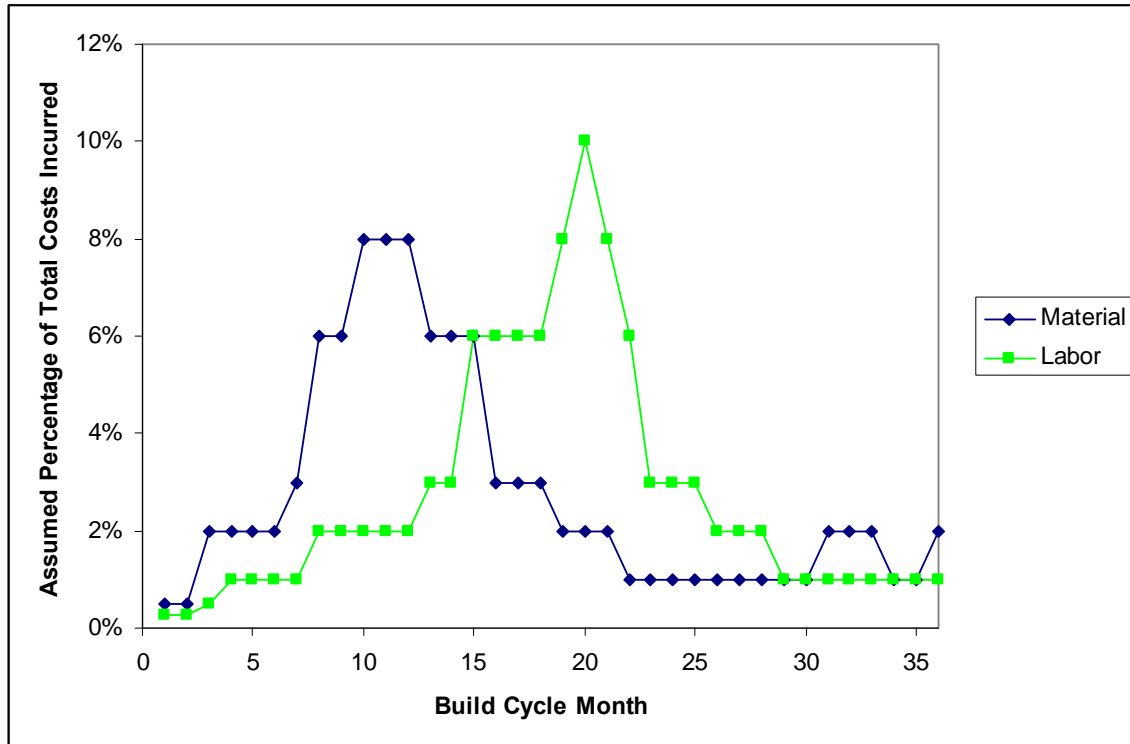




## Appendix 1. Time-phasing Material- and Labor-cost Indexes

In the examples in the body of this paper, we unrealistically assume all shipbuilder expenses are borne at the end of the three-year build cycle; we then use the material and labor-cost index values at the end of the build cycle to determine the Navy's payment to the shipbuilder.

In fact, actual Navy shipbuilding contracts are more sophisticated. Instead of assuming all costs are incurred at the end of the build cycle, a month-by-month expenditure pattern is assumed, an illustrative example of which is presented in Figure A.1.



**Figure A.1. An Illustration of Assumed Percentages of Total Costs Incurred by Month**

Figure A.1, like most Navy shipbuilding contracts, assumes the shipbuilder generally bears material costs (e.g., buying keel steel) in front of labor costs.<sup>19</sup>

The effect of this cost time-phasing assumption is to move forward the implicit median date of contractor expenditure and, therefore, to reduce (assuming the labor and material-cost indexes generally increase) the shipbuilder's inflation-related adjustment. This reduction is generally more marked for material costs because of the standard assumption material costs are borne sooner.

<sup>19</sup> Standard shipbuilding contracts do not, however, differentiate between types of material. An enhancement we urge the Navy to consider would be to break up material costs, e.g., assume steel expenditures for the keel precede electronics-type expenditures for onboard weapon systems.

**Revisiting a Very Simple Example.** As above, let us suppose the Navy signs a fixed-price contract for a ship on January 1, 2007, with completion scheduled for January 1, 2010. We assume the ship has \$100 million each in expected labor and material costs plus an additional expected or target profit of \$20 million. However, labor and material costs are expected to be borne in accord with Figure A.1's pattern.

Let us suppose, during the period 2007-2010, the external labor-cost index designated in the contract goes up 5% while the designated material-cost index goes up 20%. In addition, (though one need not make this pedagogically simplifying assumption) those increases occur uniformly over the 36-month build period. Then the effective increase in assumed labor costs (given Figure A.1's cost incurrence pattern) is 2.6%, while the increase in material costs is 8.1%. Notice the effective increase in labor costs is 52% of the 3-year total increase, while the effective increase in material costs is 40% of the 3-year total increase; this differential reflects the assumption that material costs generally precede labor costs.

In the "Very Simple Example's" contract, the Navy's actual payment to the shipbuilder would be \$230.7 million (\$102.6 million for labor, \$108.1 million for material, \$20 million for target profit).

Time-phasing contracts does not axiomatically imply reduced shipbuilder profits (though one might draw such an inference from juxtaposing this example to the body of the paper's "Very Simple Example"). The shipbuilder's initial bid will be made cognizant of how (and whether) labor and material costs are to be indexed. A less generous (but more accurate) indexing approach of this sort will doubtlessly cause the shipbuilder's bid to be greater.

**Revisiting a More Realistic Example.** In our "More Realistic Example," the Navy provided the shipbuilder with an FPIF contract with a 50/50 sharing ratio on increases or decreases in costs.

As noted above, if the labor-cost index designated in the contract goes up 5% in three years, while the designated material-cost index goes up 20%. The effective increases in the indexes are 2.6% and 8.1%, respectively, adjusting for Figure A.1's assumed expenditure pattern.

In "A More Realistic Example," we had actual labor costs of \$105 million. If we scaled this value down in accordance with Figure A.1, the "adjusted" actual labor costs would be \$102.6 million. Similarly, "adjusted" actual material costs would be \$106.1 million.

The labor compensation adjustment would now be \$2.6 million ((0.026 divided by 1.026) multiplied by \$102.6 million). The material cost adjustment would be \$8.0 million ((0.081 divided by 1.081) multiplied by \$106.1 million). The de-escalated base costs of the ship would be \$198.1 million (the "adjusted" actual \$102.6 million in labor and \$106.1 million in material less the compensation adjustments of \$2.6 million for labor and \$8.0 million for material). The shipbuilder profit would be increased by \$0.9 million.

As in the body of the paper, the shipbuilder's profit is greater, holding its actual incurred costs constant, when the material-cost index grows more. The effect of time-phasing is to roughly halve (more of a reduction for material than for labor) the measured indexed inflation rate. But the comparative static result that the shipbuilder is better off



when the material-cost index rises more, holding costs constant, remains. Again, such rewards are appropriate if shipbuilder management held costs down better than might have been expected. Conversely, if greater profits were received because an index used to calculate escalation payments is flawed, unwarranted profits may result.



THIS PAGE INTENTIONALLY LEFT BLANK



## Panel 15 - Key Issues in Defence Acquisition for the UK - Issues for other Nations?

<b>Thursday, May 15, 2008</b>	<b>Panel 15 – Key Issues in Defence Acquisition for the UK - Issues for other Nations?</b>
<b>1:45 a.m. – 3:15 p.m.</b>	<b>Chair:</b>  <b>Dr. Trevor Taylor</b> , Head of the Department of Defence Management and Security Analysis Cranfield University, Defence Academy of the United Kingdom  <b>Discussants:</b>  <b>Peter Tatham</b> , Commodore (ret.), Defence Acquisition Management Deputy Course Director, Cranfield University, Defence Academy of the United Kingdom  <b>Dr. David M. Moore</b> , Head of the Acquisition and Logistics Unit, Cranfield University, Defence Academy of the United Kingdom  <b>Paper:</b> <b><i>Five Key Changes for the Management of UK Defence—An Agenda for Research?</i></b>  <b>Peter Tatham</b> , Commodore (ret.), Defence Acquisition Management Deputy Course Director, Cranfield University, Defence Academy of the United Kingdom and <b>Dr. David M. Moore</b> , Head of the Acquisition and Logistics Unit, Cranfield University, Defence Academy of the United Kingdom

**Chair: Dr. Trevor Taylor** is Head of the Department of Defence Management and Security Analysis at Cranfield University 's faculty at the Defence Academy of the UK. He was previously Professor of International Relations at Staffordshire University, and between 1990 and 1993 was Head of the International Security Programme at the Royal Institute of International Affairs (Chatham House) in London. He is a past Chairman of the British International Studies Association, and has been Visiting Professor at the National Defence Academy in Tokyo.

Taylor takes a close interest in the UK Smart Acquisition initiative, and teaches defence acquisition on his Department's Master in Defence Administration, Defence Logistics Management and Defence Acquisition Management degrees. He contributes also to the seven-week and two-week courses on the Management and Governance of Defence that support the UK's Conflict Prevention initiatives.

In 1999, he facilitated the initial short courses in Smart Acquisition training for staff of the MoD's Equipment Capability Customer, and he was appointed in the summer of 2000 as the leader of the Non-Advocate Review Team for Project Bowman, a peer review group supporting the IPT Leader and reporting to the (former) Equipment Approvals Committee. He was elected to the Council of the Defence Manufacturers' Association in 2001 and re-elected in 2004. He was appointed as a member of the Markets sub-group of the Department of Trade and Industry Aerospace Innovation & Growth team in September 2002. In 2006, he formed part of the industrial consultation panel for the MoD's Sustained Armoured Vehicle Capability Pathfinder group, which was set up as part of the British Defence Industrial Strategy document of 2005.



He has published extensively on European security and defence industrial issues. His article entitled "The Delineation of Defense Equipment Projects in the UK Ministry of Defense" was published in *Defense and Security Analysis* in June 2004 (20(2)); his article "Governments and Industry" was published in *RUSI Defense Systems*, Summer 2004 (7(1)); and his article "The Place of Management in Defence (and Defence Education)" was published in the *RUSI Journal* April 2005 (150(2), 24-28).

Other recent publications and presentations include chapters on "The Functions of a Defence Ministry" and "Defence Acquisition" in L. Cleary & T. McConville (eds.), *Managing Defence in a Democracy* (London: Routledge, 2006); "Globalisation in the Defence Industry" in *Defence and Peace Economics* (12(3/4)); joint editorship of *A Comparison of the Defense Acquisition Systems of France, Great Britain, Germany and the United States* (VA: Defense Systems Management College Press, 1999); "Europe's Revolution in Defence Industrial Affairs," in R. Matthews (ed.), *Managing the Revolution in Military Affairs* (London: Palgrave, 2001); and "Arms Procurement" in J. Howarth & A. Menon (eds.), *The European Union and National Defence Policy* (London: Routledge, 1997). His writing on Smart Procurement includes pieces in the *RUSI Journal* in April 1998 (143(2)) and June 1999 (144(3)) and an article, "Smart Procurement and the Aerospace Sector," in the *International Journal of Aerospace Management*, June 2001 (1(2)).

**Discussant: Peter Tatham** joined the Royal Navy in 1970 and served in a variety of appointments during his career of some 35 years. Highlights include Logistics Officer of the Aircraft Carrier HMS INVINCIBLE in 1994/5 during Operations in Bosnia against the Former Republic of Yugoslavia and Chief Staff Officer responsible for all high-level Personnel and Logistics issues emanating from the 10,000 sailors and 30 surface ships in the Royal Navy (1999-2000). His final three years in the Service were spent in the Defence Logistics Organisation, where he was responsible for key elements of the internal programme of Change Management (2000-2004). During this period, he also gained an MSc in Defence Logistic Management. Following his retirement from the RN, he joined the staff of Cranfield University, where he lectures on Defence and Humanitarian Logistics. He is also carrying out his Doctoral research into the issues surrounding the role of shared values within military supply networks.

**Discussant: David Moore** worked in purchasing, logistics and supply chain management within public sector and commercial organisations before entering academia. With the University of Glamorgan, he developed and delivered Chartered Institute of Purchasing and Supply (CIPS) courses for organisations such as British Airways, London Underground and the Civil Service College. These were followed by the development and leadership of the MBA full-time and part-time programs, as well as the MBA "by Directed Learning in Bahrain." In 1996, he joined Cranfield University, where he initiated the BSc (Hons) Management and Logistics course and then the MSc Defence Logistics Management. Most recently, he designed, developed and delivered the MSc Defence Acquisition Management course for which he is now Course Director. He has undertaken extensive education, training, and consultancy assignments in the UK, USA, Europe, Middle East and Far East for organisations such as Shell, British Gas, NHS, Welsh Office, Coca Cola, Qatar Steel and the Arab Ship Repair Yard. He has also spoken at conferences around the globe. Particular interests include outsourcing, the use of contractors for service provision, and developing effectiveness through professionalism. He has written a number of books and book chapters plus conference and journal papers. Moore served in the RLC (TA) until 1999, and held both staff and CO appointments as Lt Colonel. His doctoral research was focused upon "Knowledge as the Basis of Professionalism in Procurement, Logistics and Supply Chain Management." He has been interested for some time in the commercialised approaches to logistics and their application in humanitarian aid scenarios, and especially the use of military logistics solutions within such situations.



# Five Key Changes for the Management of UK Defence—An Agenda for Research?

---

**Presenter: Peter Tatham**, Commodore (ret.), Defence Acquisition Management Deputy Course Director, Cranfield University, Defence Academy of the United Kingdom

Peter Tatham  
Department of Defence Management and Security Analysis  
Cranfield University  
DCMT Shrivenham, Swindon, Wilts, SN6 8LA, UK  
Phone: +44 (0) 1793 785286  
Fax: +44 (0) 1793 785771  
Email: [ptatham.cu@defenceacademy.mod.uk](mailto:ptatham.cu@defenceacademy.mod.uk)

**Dr. Trevor Taylor**, Head of the Department of Defence Management and Security Analysis  
Cranfield University, Defence Academy of the United Kingdom

Trevor Taylor  
Department of Defence Management and Security Analysis  
Cranfield University  
DCMT Shrivenham, Swindon, Wilts, SN6 8LA, UK  
Phone: +44 (0) 1793 785286  
Fax: +44 (0) 1793 785771  
Email: [ttaylor.cu@defenceacademy.mod.uk](mailto:ttaylor.cu@defenceacademy.mod.uk)

---

## Abstract

This paper is conceptual in nature and reviews five of the key management challenges facing those charged with the management of the UK Defence. It is argued that similar challenges face many Western governments, albeit the solutions are likely to be country-specific. Given the paucity of academic research into the general area of defence management, it is suggested that there is considerable potential for focussed application of ideas and concepts from a broad range of disciplines that will help improve the UK's ability to maintain its peacetime military capability efficiently whilst retaining its capacity to conduct operations effectively. Whilst the paper does not seek to recommend solutions for the issues identified, it does seek to expose the essential features as a means of broadening the understanding of the nature of the challenge—and, hence, to help shape the research agenda.

## Introduction

By any dispassionate measure, the management of a major state's defence needs is a hugely complex challenge. People, training, equipment, information, infrastructure and other resources have to be integrated to generate the required operational capability. Some spending makes an immediate and direct contribution to capability, while other investments—most notably in defence research and development—may not produce usable assets for a decade or more (Taylor, 2005). In a basic sense, the outputs of defence spending can be expressed in terms of units of forces at specified rates of readiness (with concomitant levels of manning, equipment, individual and collective training), but this disguises the range of missions for which forces may be expected to be ready. The then-British Prime Minister Tony Blair (2007) and General Sir John Kiszely (2006) have pointed out the challenges of maintaining forces that are ready both for high-intensity combat operations and for peace-support activities. In practice, things are even more complex—





within the area of UK defence planning assumptions, there is a seven-layer taxonomy of military operations from Deliberate Intervention to Evacuation of Non-combatants. Even more importantly, there are, increasingly, no hard and fast geographic or temporal divisions in the operational environment. Hence, as observed by the recently retired NATO Deputy Supreme Allied Commander for Transformation, we have the development of what is becoming known as the “three block war.” “In both theatres [Iraq & Afghanistan] we have had high tempo warfighting taking place in the same 50km square and at the same time as peacekeeping and humanitarian aid operations” (Forbes, 2004).

The aim of this paper is, based on the authors’ extensive experience of studying and implementing defence management, to consider some of the key managerial challenges that face those who are charged with planning, directing, organising, coordinating, monitoring and improving the use of the resources directed to the defence sector. The paper will not seek to identify any assured route to success; rather, given that a prior condition for any such prescription is awareness of the pitfalls, dilemmas and issues that need to be addressed, this paper offers a view of five of the most important challenges that will be faced by those charged with the higher management of defence. It has a UK focus and illustrates the challenges identified with British examples, but the dilemmas it identifies are of universal application. The paper is, therefore, of interest to a wider audience than just those in the UK.

Any consideration of defence management must take into account contextual factors in addition to the operational and capability issues noted above. In the UK (and in many other states) some important elements are:

The increasing complexity and capability of military platforms, equipment and information systems that, while bringing clear benefit in the actual prosecution of warfighting, involves extensive acquisition and support costs. These have been estimated by a recent authoritative report to account for 40% of the UK defence budget (MOD, 2006, June)—a figure that could rise by as much as 20% if it were to include the costs of the engineering and support Regiments within the field army, etc. It is unsurprising, therefore, that three of the five challenges considered by the authors lie in the acquisition and support arena.

Shrinking budgets and reducing “headcount” for the Armed Forces (and their civilian support staff). For example, the manpower strength of the Royal Navy has reduced, on average, by 2.25% year on year since 1950. In addition, the recent “Gershon” reforms require a reduction of 11,340 Civil Servants from the UK MOD by 2008 (MOD, 2006, p. 36).

An increasingly critical public which, whilst profoundly supportive of the individual soldier, sailor and airman, is unconvinced that the underpinning managerial structures are “fit for purpose.” This was underlined by the survey of external opinion reported in the *MOD Annual Report and Accounts for 2006/7* (MOD, 2007, Table 30)—in which those indicating a “favourable impression” of the Armed Forces was 76%, whereas those with a “favourable impression” of the MOD was just under half at 44%.

Given the breadth and depth of the management challenges in defence, it is surprising that, unlike the study of commercial management that has expanded rapidly since



the end of the Second World War, defence gets comparatively little attention from scholars.<sup>20</sup> This lack of academic interest in the management of defence may simply be because it is significantly different from everything else or because it requires too much specialistic background knowledge for the generic management expert to make sense of it without significant effort. Therefore, this paper, with the five challenges discussed below, is an effort to conceptualise some important defence dilemmas and choices.

## Challenge 1—Empowerment versus Coherence

Striking the right balance between achieving conformity without stifling potentially beneficial individualism is a major challenge in many areas of defence management. In wider (and mainly commercial) management thought, the empowering of individuals is seen as a key component of organisational success. As explained by Senge (1992, pp. 287-288), “localness means unleashing people’s commitment by giving them the freedom to act, to try out their own idea and be responsible for producing results.” He also added that, “localness is especially vital in times of rapid change,” when people lower down the organisation need a clearer sense of what is happening to them and how they can best respond. Similarly, Cole (2004, pp. 201-202) observes that, “the best practice is to be found in organisations that use delegation positively as an important employee motivator as well as a means of facilitating effective decision-making throughout the enterprise.”

In the operational military context, British Defence Doctrine<sup>21</sup> emphasises the concept of “Mission Command,” in which the high-level commander’s Strategic Intent is clearly spelled out. Subordinates are then encouraged and empowered to implement this objective as they see fit under the emerging operational circumstances.

A similar theoretical approach has been adopted in the UK’s Smart Acquisition<sup>22</sup> (SA) programme, which is designed—against the background of some 800 projects which are being developed through around 100 Integrated Project Teams (IPTs)—to ensure the introduction and support of defence equipment “Faster, Cheaper, Better and More Effectively Integrated.” The underlying SA philosophy was designed to “empower” the IPT Leaders (and, indeed, to judge them on their ability) to develop radical solutions to the delivery of military effect within a prescribed Performance, Cost and Time envelope.

---

<sup>20</sup> As an illustration, an examination of five major academic journals covering logistics and supply chain management showed that out of 1020 articles published between January 2000 and December 2007, only one discussed issues from a defence perspective.

<sup>21</sup> Doctrine is defined as “the best estimate of the way the UK’s Armed Forces [...] should go about their military business” (MOD, 2001, p. 3-1). However, as eloquently observed by the eminent historian Sir Michael Howard (1974, p. 7), the MOD cannot conduct experimentation to prove theories of warfare in the same way as a scientist; thus, inevitably, Doctrine represents an “educated guess.” He goes on to suggest that success will favour the military force that best develops “the capacity to adapt oneself to the utterly unpredictable, the entirely unknown.”

<sup>22</sup> When originally launched in 1999, the programme was called “Smart Procurement.” However, its title was changed in 2002 to “Smart Acquisition” as a means of better reflecting the whole-life implications of procurement decisions.

Unfortunately, this focus on the achievement of a successful outcome to an individual project means that IPT Leaders can be inherently reluctant to spend their budgets on managing important interfaces with other projects. It is extremely tempting to conclude that they should always be sorted out by the IPT responsible for the other side of the boundary! Furthermore, attempts to constrain IPT-level solutions in order to ensure that they allow a seamless interface with other IPTs (and virtual constructs such as the Defence Supply Chain) frequently result in an increase in the cost of the proposed solution.

The more complex<sup>23</sup> the battlefield becomes, the more prominent such project interfaces clearly become. For example, in the Army environment, a battle group will consist of the appropriate mixture of infantry, armour, and artillery to meet the threat of the moment; but the grouping is likely to be transient according to the nature of the threat faced. Integrating the logistic support for these so-called “Agile Mission Groups” in such a way that it does not constrain the commander’s freedom drives towards a unitary support solution for the operation as a whole—but this is in direct opposition to the Smart Acquisition business drive to deliver unique, optimised support targeted at a particular platform or equipment.

It is also becoming increasingly apparent that the integration problems associated with information systems are even more challenging, not least as the technology refresh rate here is measured in terms of 2-3 years (rather than the decades for, say, the transition from steam to gas turbine as a means of maritime propulsion). The challenge of integrating Information Systems is also exacerbated by both the internal demands of the UK’s Network Enabled Capability<sup>24</sup> (NEC) and the desire to link, on the one hand, to US systems and, on the other, to those of our European allies.

In order to resolve this conundrum, a number of concepts have been championed. For example, some look to the expert use of systems engineering techniques (see Stevens, Jackson, Brook & Arnold, 1998); others suggest that a central guidance and lobbying body such as the Integration Authority within the UK’s Defence Equipment and Support (DE&S) organisation can make the required impact. A further alternative prescribes defining “open system architectures” to allow easy integration and modification of modules—but none of these approaches has yet to prove entirely satisfactory.

Nevertheless, one procurement choice that is currently gaining attention recommends seeking out companies with generic systems integration expertise, as signalled by the UK selection of W.S. Atkins for the British Future Rapid Effects System (FRES) programme. That said, it has been observed that the Lead Systems Integrator role in the US has driven companies to seek to win contracts only in weapons areas in which they have little specialist expertise (Moon & Schoder, 2005).

Perhaps the optimum approach is a more modest one, in which separate systems are procured, then integrated through a series of *ad hoc* patches; these may be in the form of software and hardware, or they may involve putting a human in the loop. Indeed, such an approach aligns well with the concept of Incremental Acquisition in which the required

---

<sup>23</sup> Such complexity arises not only within an environment (e.g., Land, Sea or Air), but because current and future operations increasingly (indeed, probably, inevitably) require the joint effects of two (if not all three) Services.

<sup>24</sup> For a series of short articles dealing with the acquisition of Network Enabled Capability, see (2004, July). *RUSI Defence Systems*, 7(1), pp. 62-85.

capability is achieved through a number of relatively small (and, thus, from a scientific or engineering perspective, less risky) advances. This has the benefit of allowing adjustments in emphasis to be made as the nature of the threat unfolds, but invariably involves additional expense not provided for in the budgets of individual projects.

The centralisation-delegation pendulum has undoubtedly swung back and forth over the last five years with the initial development of a voluntary “Support Solutions Envelope” designed to curtail the more extreme approaches. However, this is now being modified, and the current trend is clearly towards constraining the IPT Leaders rather than giving them greater discretion, but this of course means that focus on and commitment to achieving the specific project goals may be weakened. Striking the right balance between empowerment of the IPT Leader to develop novel solutions and achieving coherence of support for, say, all the equipment in a Brigade Group is a fascinating, but extremely challenging, balancing act. Furthermore, as indicated earlier, the balance chosen is likely to reflect cultural and other environmental factors; for example, from an external perspective, the US defence machine, in both operational and managerial sectors, often appears more centrally directed and rule-bound than that found in the UK.

Another area in which the Empowerment v Coherence tensions can be readily observed is in the subtle balance between the role of the single Service Commanders-in-Chief and that of the Chief of Joint Operations. Current UK operational thinking, supported by recent experience in several theatres, emphasises the need for “jointery”—but, for good reason, the peacetime programme designed to ensure the maintenance of a particular capability tends to be undertaken on a component (i.e., Navy/Army/Air Force) basis. This leads, not least, to the reinforcement of cultural differences that need to be quickly overcome when a joint force is fielded. The UK is becoming increasingly aware of the need to approach both managerial and operational issues from a joint perspective, but this prescription may not be appropriate to every country. Nevertheless, many, if not all, will need to develop the appropriate mechanism to ensure the coherence of military output without diminishing the essential differences between the components.

## Challenge 2—What should the governmental defence sector do for itself, and what should it outsource from others?

Even in the US, in modern times, western governments do not develop and produce all the goods and services that their armed forces need. This is equally true of states such as France, Italy and Turkey, where notwithstanding the presence (even in the early 21<sup>st</sup> Century) of a large nationalised defence industrial sector, their Ministries of Defence still look to private firms for the provision of the sort of products used by the general population (such as food), as well as those emanating from high-technology sectors (such as electronics and aerospace). However, driven mainly by a belief that private firms working in a competitive environment are more efficient than publicly owned monopolies, some countries (with the UK in the lead) have undertaken a significant programme of privatisation of their state-owned, defence-related industries. For example, over the last two decades, the Royal Dockyards and Royal Ordnance Factories have become fully fledged businesses within the private sector; indeed, even the UK’s nuclear weapons plants, whilst still formally owned by the government, are managed and operated for the government by a private contractor.



Furthermore, the UK (along with the US and others) has increasingly outsourced the design, development and production of defence equipment to the private sector. In addition, the UK Ministry of Defence has not been immune from the general pan-Whitehall drive to implement the government's Private Finance Initiative (PFI) and Public-private Partnerships<sup>25</sup> (PPP). For example, a recent review (RUSI, 2004) indicated that between 1995 and December 2003, the MOD had signed contracts for 45 PFI projects and 6 PPP arrangements—involving some £3.5 billion of capital costs, and with the annual payments representing some 6% of the Defence budget. Furthermore, as an indication of the increasing momentum behind this approach, another 37 projects (worth some £12 billion) were at that time either under consideration or in the process of going to contract.

Unsurprisingly, the areas of business initially transferred out were those providing support services such as cleaning and catering. This was followed by a second wave of projects covering a broad swathe of training functions, including, for example, that for armoured vehicle drivers and for helicopter and fixed-wing aircraft pilots. However, recent initiatives have been significantly more ambitious and are increasingly linked with the overall model for the transition of defence support.

In essence, in developing this policy, the then-UK Chief of Defence Logistics (CDL) believed that in order to improve the reliability of military equipment—with the concomitant beneficial effects in terms of, for example, a reduction in both Through-life Costs and a reduced logistics footprint on operations—it was necessary to engage commerce and industry more closely in the delivery of military effect. The net result has been a developing generation of PFIs that sees the capital cost of military equipment being borne by industry—which also provides ongoing support in the shape of some or all of maintenance, training (of both operators and military engineering staff), management of obsolescence and provision of spare parts. Recent examples of this include the Skynet 5 satellite system, the £600 million contract for the provision of so-called “C” vehicles<sup>26</sup> announced in June 2005, and the Future Strategic Tanker Aircraft (FSTA) which requires industry to raise some £3 billion—making this, by far, the largest UK PFI ever contemplated.

Significantly, the use of contractors for many of these roles is not restricted to home activities, but also extends to deployed operations. As a result, there is now a real debate as to the extent to which governments should rely on Contractors on Deployed Operations (CONDO)<sup>27</sup>. For example, Ukrainian companies have become major suppliers of air

---

<sup>25</sup> Whilst there are financial and accounting distinctions between PFI and PPP programmes, the essence of both is that private (i.e., non-government) funding is used to provide the capital cost of, say, a new building. This is paid back by defence over the long term (typically in excess of 20 years) by means of a stream of rental income. In all probability, the totality of these annual payments will exceed the cost of in-house provision, but this is tolerated not only because of the extent to which “spikes” in capital expenditure (which represents some 25% of the Defence budget) can be reduced, but also because of the beneficial effects on the Public Sector Borrowing Requirement (PSBR) and the reduced headcount that is directly funded from the government's payroll.

<sup>26</sup> Military vehicles can be broken down into generic groups: “A” vehicles include armoured platforms such as tanks. “B” vehicles cover the soft-skin group such as 4x4 vehicles. The “C” vehicle category includes engineering plant such as bulldozers and earthmovers. The final category is known as the “White Fleet,” which covers all forms of staff cars and minibuses which are already provided through a PFI contract.

<sup>27</sup> See, for instance, a series of articles in (2004, Summer). *Defence Studies*, 4(2).



transport to the UK defence establishment, while Kellogg, Brown & Root holds an enabling contract (known as “CONLOG”) to provide a whole range of services in support of UK operations, and the next generation of air-to-air refuelling aircraft is highly likely to be contracted under a CONDO arrangement. The leading edge of this generation of CLS initiatives is that of the Heavy Equipment (e.g., Tank) Transporter (HET) fleet, in which 1/3 of the drivers and maintainers are civilians who, as a condition of their employment, must accept Reservist status. The benefit of this approach is that the drivers can, at short notice, be “re-badged” as military personnel with minimal interruption to the level of support provided. A similar approach has recently been agreed for the RAPIER Ground-to-Air missile system; the operationally deployable 2<sup>nd</sup> Line test and repair facility formerly manned by military technicians is now being provided by the company (MBDA) using the “sponsored reserve” concept.

In pursuing the outsourcing route, the UK MOD is clearly following guidance from the literature of commercial management. For example, writers in this field such as Hamel & Prahalad (1994) and Johnson, Scholes and Whittington (2005) recommend that companies should seek to identify their “core competencies”—i.e., areas in which they excel and, thus, hold competitive advantage. These authors assert that companies should contract with others that have particular expertise for other necessary, but non-core, functions. Unfortunately, what is lacking currently in the UK (and, arguably in most Western nations) is any clear view about what the core competencies of the governmental defence sector are and need to be.

A further implication of outsourcing is that it changes the nature of one of the more significant challenges facing any organisation—namely how to select one’s suppliers. There are many prescriptions developed by academics and practitioners, but no sure route to success. Outsourcing should not be used to avoid a difficult problem, and defence, which buys complex products and services, is certainly taking on risk if it entrusts provision to prime contractors without detailed oversight of how those primes will deal with the supply chains below them. In many cases, the UK has little choice regarding a prime, since BAES is the supplier of 90% of land platforms and 80% of fixed-wing aircraft, and so cannot introduce supply chain management as a significant element in a competitive tendering activity.

One area in which the MoD (but not the Government as a whole) has drawn the line is in its refusal to place lethal force in the hands of contractors, though contractors are certainly being placed nearer to the front line.<sup>28</sup> However, it has been reported that the Royal Norwegian Navy’s Fridtjoff Nansen class frigates are taking outsourcing to novel territory. They will remain in the ownership of IZAR, their Spanish shipbuilders, who will be not only responsible for the support and maintenance of the ships, but will also provide one third of the crew (Cushway, 2006).

This increasing use of CONDO underlines two challenges. First, there is a need to ensure the integration of the output of potentially disparate groups of contractors to provide

---

<sup>28</sup> Interestingly, the US Department of Defense (DoD) has gone even further by accepting that private military companies can arm their personnel for such tasks as guarding oil fields and associated facilities such as pumping installations, etc. Indeed, there may be as many as 20,000 armed guards in Iraq under US contracts—albeit many are not of American or Iraqi nationality.



“joined up” logistics in support of the front-line troops. This requires greater imposition of common standards in many areas—including information systems, health and safety, and welfare/discipline, etc. Secondly, and perhaps even more importantly, it raises the question of how the services that they are delivering will be provided if a previously benign area becomes markedly more dangerous. This is a difficult balancing act in this era of asymmetric warfare— particularly if the UK follows the US lead and, for example, deploys contractors in direct support of armoured vehicles. This approach is used to support its Stryker Brigade, in which

“Approximately 120 specialized contractors are an integral part of the Stryker Brigade Combat Teams’ (SCBTs) highly complex systems maintenance, sustainment and technical support. [...] many contractors are actually operating in the forward areas of the SBCT” (Alderete, 2005; GAO, 2003, June).

A decision to outsource requires not just the confidence that an external supplier should be able to provide a capability or service more effectively and efficiently. There must be confidence that the contractor can be incentivised to perform reliably, even when the physical and/or political environment has become challenging. This is obviously most relevant in the military operational context, but there must also be a viable procurement strategy available that will give the outsourcing authority confidence that value can be obtained. This is increasingly leading to the development of “Partnering” solutions that combine elements of both PPP/PFI and Outsourcing.

### Challenge 3—How should support for equipment be arranged in a time of frequent and surprising operations?

Across the broad swathe of UK military commentators, there is a clear recognition that the current defence supply chain model needs to be significantly developed from that originally created to support the British Army when facing a potential Soviet threat on the plains of Northern Germany. In considering how it should be improved, planners are faced with exhortations that supply chains should be “lean” and use a “just-in-time” approach modelled on commercial operations such as those providing fast-moving consumer goods (FCMG). Such a prescription is potentially attractive, not least as it is believed that it will enable a reduction in the existing stockpiles and, hence, reduce financial overheads. However, the Armed Forces, whose lives depend on stocks of ammunition and spare parts being replenished promptly, have traditionally preferred a “just-in-case” approach. This feeling is well captured by the then-US Assistant Secretary for Defense who observed that, “In the absence of rock solid information regarding the availability of materiel, the warfighter will always buy readiness insurance in the form of excess local stocks” (Kaminski, 1996). On the other hand, carelessness or mismanagement can also lead to stocks being held for contingencies that have long become unthinkable. For instance, the establishment of the UK’s Defence Logistics Organisation (DLO) in 2000 led to the discovery of jigs and tools that would have supported the re-launched production of 2<sup>nd</sup> World War-type aircraft!

From an academic perspective, the reluctance to embrace the “just-in-time” (JIT) model is entirely logical, as this concept operates best when demand is relatively stable and, hence, predictable (Towill & Christopher, 2002). This, unsurprisingly, sits uncomfortably with the doubly unpredictable nature of warfare, in which we cannot be confident about the timing and location of military operations, or about precisely how they will unfold once they have begun. Thus, the alternative “Agile” supply chain management model would appear





more promising in a military context as it recognises that all forecasts are inherently imperfect and is, therefore, designed “to thrive and prosper in an environment of constant and unpredictable change” (Maskell, 2001).

The conflicts in Iraq and Afghanistan are exceptional and, since 1945, the requirement for the UK’s Armed Forces to prosecute the Queen’s enemies has been applied infrequently. Certainly, large numbers of UK troops are often engaged in hazardous missions, but the periods of time in which they are fighting in a major conflict (as distinct from Peace Support or Peace Enforcement Operations) are relatively short—perhaps for some six months during a ten-year window. Therefore, use of an efficient business model makes good sense in peacetime when the armed forces are, typically, engaged in routine training in order to ensure that they develop and maintain their expertise. The consequences of a vehicle breakdown, and any delay to its repair or replacement, may result in a waste of valuable resources and be very frustrating for all concerned—but rarely is life put at risk. Contrast this with the operational situation in which supply chain failures can, and regrettably do, lead directly or indirectly to death or injury. Thus, the operational supply chain must be optimised towards effectiveness (with its certainty of supply) rather than efficiency.

Thus, the Defence Supply Chain sits firmly on the horns of a dilemma: whether to reduce inventories in order to reap the peacetime efficiency benefits, or to continue to pay this “insurance” cost in order to help ensure the effectiveness essential for successful operations. In theory, there will be an optimum level of “leanness” (Christopher & Rutherford, 2004)—but ascertaining this for each of 1.7 million SKUs,<sup>29</sup> in the face of the uncertain future demand pattern that is the inevitable consequence of the uncertain nature of future warfare, may well be beyond even a significant investment in sophisticated modelling. Hence, it is unsurprising that the military response to a combination of uncertain demand and long-lead time supply characteristics is likely to continue to result in significant stockpiling—but it is just such stockpiling that then becomes a target for challenge in subsequent spending rounds.

To the stresses between JIT and Agile must be added the dimension of resilience: that supply chains should be able to avoid or absorb shock. Arguably, defence needs to take evaluate risks to effective supply, including reliance on single plants that may be destroyed in fires or other accidents. Stocks in different locations can clearly enhance resilience, but such strength rarely comes without cost. Costs must always be weighed against the perceived risks—but persuading those who control the defence purse strings of the merits of these observations generally remains an unmastered challenge.

Overall, however, the response of the UK MOD has been to enhance the importance of potential operations in the planning and management of the DE&S organisation. The UK also is giving increased recognition to security of supply in times of crisis—for instance in the 1998 *Letter of Intent with European States*<sup>30</sup> and the 2000 *Declaration of Principles with the United States*. Perhaps significantly, Switzerland—a relatively friendly country—placed an

---

<sup>29</sup> SKUs = Stock Keeping Units. The UK’s defence inventory should be compared with the 20-30,000 SKUs that might be found in a typical supermarket outlet (Fernie & Sparks, 1999).

<sup>30</sup> It is planned that this Letter of Intent will be developed through the introduction of *EU Code of Conduct on Defence Procurement* (MOD, 2005, p. 7).

embargo on the export of grenades to the UK as a reflection of its government's disapproval of the 2003 Iraq War (NAO, 2003). Fortunately, this had no tangible effect on the outcome as sufficient had been stockpiled, but it was a salutary lesson for planners.

It is suggested that the keys to the MOD's difficulty here are threefold. Firstly, there has been a solid record of recent operational success. It is argued, therefore, that "warts and all," the current system which, whilst clearly not perfect, may be just about as good as it will get given the variables in play. This "do nothing" (other than to continue to tune the system) approach clearly has advantages for those within the MOD and industry whose interests are well served by it. Challenging these power bases without a clear idea of what the successor system will look like is a career-threatening move in any arena!

Secondly, the lead time for a significant volume of materiel support is long and, in many cases, growing. This is generally the result of the niche-status of defence engineering (both mechanical and electronic) and its relative lack of players (as discussed above). Given that defence is generally recognised as not following the normal economists' model of a perfect market, there is only limited pressure that can be placed on those remaining companies to improve their performance—especially in the time dimension. This exacerbates the pressure on individual IPTs to take the easy (and generally risk-free) option of developing stockpiles rather than seeking more agile solutions. But as the move towards partnering takes greater hold with its metrics based around delivering an agreed-upon level of equipment availability, this decision is transferred to the industrial partner that must increasingly make such stock-level decisions. Experience to date would indicate that such partners are up to this task, but there is a large and diverse body of academic literature that raises fundamental concerns over the effectiveness of such collaboration arrangements (Kampstra, Ashayeri & Gattorna, 2006). Thus, the inevitable nervousness of operational commanders over this fundamental transference of risk may yet prove well-placed.

The final point is that the capability-based approach is rare, perhaps even unique to Defence. No other organisation spends almost the totality of its budget in the development of a capability (across equipment, communications, personnel, training, infrastructure, operational planning, etc) and then returns to its shareholders (in the MOD's case the Treasury) for additional finance when they are actually required to employ this capability. Even major public-sector ventures such as hospitals and schools aim to balance the supply (of operating theatres, nurses, classrooms, teachers) against steady state demand. Peaks can be accommodated through a number of mechanisms (geographic dispersion of the requirement, building temporary facilities, hiring agency staff) in relatively short order. Thus, unlike the MOD with its massive equipment lead times, the risk from adopting a surge (rather than a stockpile) model is relatively containable.

As a result, the MOD has no obvious commercial comparators against which it can benchmark its activities and is generally constrained by the extremely coarse level of public expenditure. That said, there is an implicit recognition that a country cannot undertake major military operations without the support of a capable industry. But, generally, there is a reluctance to confront too squarely the additional costs that have to be incurred in peacetime to ensure that sustainability can be assured in war.



## Challenge 4—In an era of rapid progress in civil technology, how does a Ministry of Defence assure its optimum inclusion into defence systems?

Forty years ago, research and development in the West was dominated by military spending. Today, this is no longer the case; technological advance in many sectors, including computing and IT and biotechnology, is almost entirely driven by civil spending. Even in the UK, where defence Research and Development (R&D) is comparatively important compared with other EU members (except France), defence accounts for only 11% of the national R&D effort (National Statistics, 2005). This increasing focus on the R&D requirements of commerce and industry raises the fundamental question of how defence can minimise the chances that it will not miss out on opportunities that may arise in the civilian context.

As part of its response to this challenge, the UK MOD devotes some time and resources simply to tracking progress in civil technology across the board and across the world. It also operates a small organisation within the DE&S (the Defence Suppliers' Service) that familiarises businesses seeking work in the defence sector with the contractual and other processes of the Ministry of Defence and, in this way, tries to ease the path of firms that wish to become suppliers. On the other hand, the US Department of Defense has particular accounting demands that it places on its suppliers; this has led to concerns that some generators of "civil" technology do not promote it in the defence sector simply because they do not want the trouble of complying with these accounting systems.

Little in this area is easy. Much contemporary technology—especially that which relies heavily on electronics—has a very short lifecycle and is kept in production for only a limited time. Culturally and procedurally, the UK MOD has developed an increasingly robust process for the careful assessment of equipment investment that is able to handle programmes with a planned lifetime of two or three decades (albeit many, with subsequent life extension programmes, have the period from Concept to Disposal often exceeding 50 years (DEG, 2005)). The Investment Approvals Board<sup>31</sup> (IAB) is, therefore, not accustomed to hearing that a piece of kit will be disposed of after perhaps three or four years—which is frequently shorter than the approvals process itself!

Furthermore, the building of modern computing and information technology into complex larger systems also raises questions about whether and how that technology can be updated without significant disruption to the system as a whole. For example, modern combat aircraft such as the F22 and the Eurofighter Typhoon contain several thousand obsolescent parts, but changing a 486 processor for a modern Pentium version is a risky business in such complex systems. To date, the UK Defence Ministry's answer to this issue has been twofold. In some cases, a lifetime supply of an item is bought at the time of procurement so that a failed component can be simply replaced from existing stock. However, this has the obvious downsides of the both the cost of maintaining such a stockpile (particularly when its usage rates may prove to be far lower than estimated at the pre-production stage), and also its vulnerability to the sort of obsolescence issues outline above.

---

<sup>31</sup> As its name implies, the IAB is the committee that sanctions proposals for major investment on behalf of the UK's Defence Management Board.



The alternative (and increasingly common) approach is to develop a support arrangement with a contractor who is obliged both to maintain the system and to update its elements under a so-called “Contracting for Availability” approach. This is particularly useful in the procurement of information systems and services and, as a result, the contractor shoulders the risk of difficulties associated with the introduction of new technology. Given that the contractor is usually the original equipment supplier, he should (in theory) understand the system better than anyone else. But, with the increasing importance accorded to the electronic dimension of a platform such as a tank, ship or aircraft, it is not surprising that some commentators have gone so far as to suggest that the electronics should lead the design: “In future, we will invite contractors to design C4ISTAR architectures and integrate platforms into them” (Blackham, 2003<sup>32</sup>).

## Challenge 5—Development of a Whole-life and pan-Organisation Cost mentality

In an overall “system of systems” as complex as Defence (which is designed to operate successfully at some distance from its home base in the most challenging and life-threatening of environments), it is inevitable that there will be overlaps and interfaces between those charged with the management, development and operation of each individual component. Thus, for example, the introduction of an improved equipment design is likely, whilst reducing the direct cost (of operation and/or spares provision), to incur additional costs in terms of infrastructure (e.g., more sophisticated diagnostic equipment) and in personnel (training of maintenance engineers to higher skill levels).

Indeed, in the UK, the military has recognized eight so-called Defence Lines of Development<sup>33</sup> (LoDs) as a means of helping ensure that the implications of equipment changes are well understood. The simplest approach sees equipment, at least after the signature of a development contract with a company, as the independent variable from which other LoDs follow: their management requires their timely and appropriate provision. A more complex line of thought presents the LoDs as interacting throughout the development process; for instance, a computer programme could be developed expensively with few training needs or more cheaply with extensive training needs. However, viewing the LoDs in this way presents significant challenges in the development of robust and meaningful contracts with industry. Intriguingly, as recognised by the UK’s Chartered Institute for Logistics and Transport, the LoD approach does seem to commend itself as a model in other areas—for example, in planning responses to Humanitarian Disasters in which the integration of many strands of support (against the backdrop of uncertainty, potentially devastated infrastructure and limited communications) has clear parallels with the military scenario.

---

<sup>32</sup> Vice Admiral Sir Jeremy Blackham was, until 2003, the officer responsible for the development of future equipment capability—the so-called “Customer 1,” whose role included the development of the User Requirements Document (URD) against which new platforms and equipment are procured.

<sup>33</sup> Known by the acronym “TEPIDOIL,” these encompass Training, Equipment, Personnel, Infrastructure, Doctrine & Concepts, Organisation, Information and Logistics.



A further twist to this multi-faceted integration problem is the increasing recognition that resource-expenditure decisions should be considered on a Whole-life cost<sup>34</sup> (WLC) basis. In many ways, it would seem to be entirely perverse not to approach such decisions from this perspective; however, there are many examples of procurement projects in defence in which the capital cost would appear to have been deliberately reduced without formally recognising the implications for the ongoing costs of support, and in the hope that the latter will be “lost in the noise” or that the corporate memory will have forgotten the original basis for the decision when it crystallises 20 years later.

It is fully accepted that Whole-life costing is an acknowledged challenge in many areas of commerce and industry, but the complexity of military equipment and the breadth of operational circumstances in which it can be (and is) used, make cost forecasting a particular challenge. As an example, many items of defence equipment are designed for use in one environment but, due to changed political or military circumstances, are actually operated in a markedly different way.<sup>35</sup> This complexity is exacerbated by the extent to which organisational structures influence the potential for “tribal” behaviour. Thus, in the UK MOD, there has been a clear separation between those who are charged with the procurement of new equipment, those who maintain it, and those who operate it in combat. Particularly in relation to the first two protagonists, this schism has reinforced the suspicion that—not least in the face of sustained criticism by the House of Commons Public Accounts and Defence Committees—misleading trade-offs between capital and support costs may be presented to scrutineers.

The merger during 2007 of the Defence Procurement Agency and the Defence Logistics Organisation—as well as wider responsibilities placed on the Equipment Capability Customer organisation—is meant to support the early adoption of realistic whole-life cost calculations. Robust methods for capturing and allocating such costs, however, will need further refinement. Nevertheless, to the extent that the need for Whole-life Costing across all the Defence LoDs has been recognised and will lead to greater attention, the Defence Industrial Strategy must be applauded.

## Conclusion

This paper has sought to review, from a largely UK perspective, some of the key challenges currently facing the management of defence and, in doing so, has addressed five inter-related questions to which there are no easy or final answers. But, this study has also suggested that the current relative paucity of academic endeavour presents a tremendous opportunity both for new insights, and also for the development and application of prescriptions that have been tried and tested in the commercial arena. Furthermore, whilst it

---

<sup>34</sup> A very useful and concise exploration of some of the key issues surrounding the development of robust WLC models is to be found in the Kirkpatrick (2000).

<sup>35</sup> A particularly clear example is the Royal Navy’s Type 23 Frigates that were designed for anti-submarine patrols to be conducted at slow (and, therefore, quiet) speed in the waters between Greenland, Iceland and Northern Scotland. Thus, given the predicted ambient temperatures, the air conditioning systems (for both equipment and crew) were limited, as was the endurance—reflecting a concept of operations that saw the vessels being accompanied by an oiler/stores support ship. Following the end of the Cold War, the ships are now seen as “General Purpose” frigates and have required expensive retrofitting to enable them to operate effectively in, say, the Persian Gulf.



is not appropriate to speak of a crisis in defence management, there is little doubt that major shortcomings in existing ways of doing business (competitive tendering, outsourcing, and relying on rather autonomous Integrated Project Teams in acquisition) are becoming ever clearer.

Finally, the authors are well aware that our selection does not cover all of the management challenges facing the UK MOD. For instance, it is not clear whether the benefits gained from the introduction of Resource Accounting and Budgeting (RAB) have exceeded the considerable implementation costs involved. That said, there is no doubt that the MOD has much to do if it is to better understand its own costs (on a Whole-life basis and across all aspects such as personnel, training, support and infrastructure) as a means of improving the significant balance of investment decisions that it faces. Also, the prevalence and successful achievement of Urgent Operational Requirements (UORs) before the Iraq War has raised questions about the actual outputs and outcomes of the peacetime defence budget, as well as the procurement process as a whole—how can the latter meet the demands of UORs but singularly fail to do so in regular procurements (especially in the absence of any clear price inflation)?

Hopefully, the issues raised in some detail will prompt some interest in the management challenges facing the defence community. They might even generate some sympathy for those charged with running a country's defence machine.

## List of References

- Alderete, G.L. (2005, March-April). Nonstandard logistics sustainment support in the Stryker Brigade combat teams. *Army Logistician*, 37(PB 700-05-2). Retrieved December 18, 2007, from [www.almc.army.mil/alog/issues/MarApr05/stryker.html](http://www.almc.army.mil/alog/issues/MarApr05/stryker.html)
- Blackham, J.J. (2003). NEC: Enabling the battlespace. *Defence Procurement Analysis*, Autumn, 15-17.
- Blair, T. (2007, January 12). Speech by Tony Blair on the role of the UK's Armed Forces in the 21<sup>st</sup> Century. Retrieved January 15, 2007, from [www.number10.gov.uk](http://www.number10.gov.uk).
- Christopher, M., & Rutherford, C. (2004). Creating supply chain resilience through agile six sigma. *Critical Eye*, June-August, 24-28.
- Cole, G.A. (2004). *Management theory and practice* (6<sup>th</sup> ed.). London: Thomson.
- Cushway, G. (2006). Availability contracting. *Defence Management Journal*, 32(1), 74-75.
- Defence Engineering Group (DEG), University College London. (2005). *Conquering complexity: Lessons for defence systems acquisition*. London: The Stationery Office.
- Fernie, J., & Sparks, L. (Eds). (1999). *Logistics and retail management*. London: CRC Press.
- Forbes, I. (2004). NATO: Equipment and transformation. *RUSI Defence Systems*, 7(1). 20-22.
- GAO. (2003, June). *Military operations: Contractors provide vital services to deployed forces but are not adequately addressed in DOD plans* (GAO-03-695). Report to the Subcommittee on Readiness and Management Support, Committee on Armed Services, US Senate. Washington, DC: Author.
- Hamel, G., & Prahalad. C. K. (1994). *Competing for the future*. Boston, MA: Harvard Business School Press.
- Howard, M. (1974, March). Military science in an age of peace. *Journal of the Royal United Services Institute*, 119, 4.



- Johnson, G., Scholes, K., & Whittington, R. (2005). *Exploring corporate strategy* (7<sup>th</sup> ed). Harlow: Pearson Education.
- Kaminski, P.G. (1996). Lean logistics: Better, faster, cheaper. *Defense Issues*, 11(99).
- Kampstra, R.P., Ashayeri, J., & Gattorna, J.L. (2006). Realities of supply chain collaboration. *The International Journal of Logistics Management*, 17(3), 312-330.
- Kirkpatrick, D. (2000, August). Whole life cost forecasting. *RUSI Journal*, 145(4), 25-29.
- Kiszley, J. (2006). Learning about counter-insurgency. *RUSI Journal*, 151(6), 16-21.
- Maskell, B. (2001). The age of agile manufacturing. *Supply Chain Management*, 6(1), 5-11.
- Ministry of Defence (MOD). (2001). *Defence Doctrine* (JWP0-01, 2<sup>nd</sup> ed). London: HMSO.
- Ministry of Defence. (2004). *The government's expenditure plans* (Cm6212). London: HMSO.
- Ministry of Defence. (2005). *Defence Industrial Strategy* (Cm6697). London: HMSO.
- Ministry of Defence. (2006). *Annual report and accounts 2005-6* (HC 1394). London: HMSO.
- Ministry of Defence. (2006, June). *Enabling acquisition change: An examination of the Ministry of Defence's ability to undertake Through Life Capability Management*. London: HMSO.
- Ministry of Defence. (2007, July 23). *Annual report and accounts 2006-7* (HC 697). London: HMSO.
- Moon, D., & Schoder, A. (2005, May 2). Give companies incentive to seek LSI role. *Defense News*.
- National Audit Office (NAO). (2003, December 11). *Report on operation TELIC* (HC60 Session 2003-2004). London: Author.
- National Statistics. (2005). *Expenditure on civil and defence research and development in the UK by sector of funding*. Retrieved June 14, 2005, from <http://www.statistics.gov.uk/STATBASE/tsdataset.asp?vlnk=533&More=N&All=Y>.
- Royal United Services Institute (RUSI). (2004). *The innovative use of private finance in defence acquisition* (Whitehall Paper No. 63). London: Author.
- Senge, P.M. (1992) *The fifth discipline: The art & practice of the learning organisation*. Sydney: Random House.
- Stevens, R., Jackson, K., Brook, P., & Arnold, S. (1998). *Systems engineering: Coping with complexity*. London: Prentice Hall.
- Taylor, T. (2005). The place of management in defence (and defence education). *RUSI Journal*, 150(2), 24-28.
- Towill, D.R., & Christopher, M. (2002). The supply chain strategy conundrum: To be lean or agile or to be lean and agile? *International Journal of Logistics: Research and Applications*, 5(3), 299-309.





THIS PAGE INTENTIONALLY LEFT BLANK



## Panel 16 - Public Procurement: Environment, Limitations and Innovations

---

<p><b>Thursday, May 15, 2008</b></p> <p><b>1:45 a.m. – 3:15 p.m.</b></p>	<p><b>Panel 16 – Public Procurement: Environment, Limitations and Innovations</b></p> <p><b>Chair:</b></p> <p><b>Dr. James T. Simpson</b>, Dean, College of Business Administration, The University of Alabama in Huntsville</p> <p><b>Papers:</b></p> <p><b><i>Public Procurement Stakeholders &amp; Aspirations</i></b></p> <p><b>Steve Schooner</b>, J.D. Senior Associate Dean for Academic Affairs Co-Director of the Government Procurement Law Program, <b>Daniel I. Gordon</b>, J.D., Professorial Lecturer in Law and <b>Jessica L. Clark</b>, J.D., Visiting Associate Professor of Legal Research and Writing The George Washington University Law School</p> <p><b><i>The Limits of Competition in Federal Contracting</i></b></p> <p><b>Gerald S. Koenig</b>, Attorney-at-Law</p> <p><b><i>Innovations in Defense Acquisition Auctions: Lessons Learned and Alternative Mechanism Designs</i></b></p> <p><b>Dr. Peter Coughlan</b>, Associate Professor, <b>Dr. William Gates</b>, Associate Professor, Naval Postgraduate School and <b>Dr. Jennifer Lamping</b>, Assistant Professor, University of Colorado</p>
--	---

---

**Chair: Dr. James T. Simpson** Dean, College of Business Administration, The University of Alabama in Huntsville

---



THIS PAGE INTENTIONALLY LEFT BLANK



## Panel 17 - Cost Estimating Initiatives in Defense Acquisition

---

<b>Thursday, May 15, 2008</b>	<b>Panel 17 - Cost Estimating Initiatives in Defense Acquisition</b>
<b>1:45 p.m. – 3:15 p.m.</b>	<p><b>Chair:</b></p> <p><b>Dr. Daniel A. Nussbaum</b>, Visiting Professor, NPS, former Director, Naval Center for Cost Analysis, Office of the Assistant Secretary of Navy (Financial Management and Comptroller)</p> <p><b>Discussants:</b></p> <p><b>Fred Hartman</b>, Research Staff, Institute for Defense Analyses, Studies and Analyses Center, Science and Technology Division</p> <p><b>Papers:</b></p> <p><b><i>A Non-simulation Based Method for Inducing Pearson's Correlation between Input Random Variables</i></b></p> <p><b>Eric R. Druker</b>, Operations Research Analyst, <b>Richard L. Coleman</b>, Director, Cost and Price Analysis Center of Excellence, <b>Peter J. Braxton</b>, Director of Training and <b>Joel B. Hughes</b>, Northrop Grumman</p> <p><b><i>Application of Transaction Cost Economics to Capabilities-based Acquisition: Exploring Single Service vs. Joint Service Programs and Single Systems vs. System-of-Systems</i></b></p> <p><b>Dr. Diana Angelis</b>, Associate Professor, <b>John Dillard</b>, Senior Lecturer, <b>Dr. Raymond (Chip) Franck</b>, Senior Lecturer, <b>Dr. Francois Melese</b>, Professor, Defense Resource Management Institute, Naval Postgraduate School, <b>Dr. Mary Maureen Brown</b>, Associate Professor, University of North Carolina, Charlotte and <b>Robert M. Flowe</b>, Office of the Deputy Under Secretary of Defense (Acquisition &amp; Technology), Software Engineering and Systems Assurance</p> <p><b><i>Transactions Cost Economics and Cost Estimation Methodology</i></b></p> <p><b>Dr. Raymond (Chip) Franck</b>, Senior Lecturer, <b>Dr. Francois Melese</b>, Professor, Defense Resource Management Institute, <b>John T. Dillard</b>, Senior Lecturer and <b>Dr. Diana Angelis</b>, Associate Professor, Naval Postgraduate School</p>

---

**Chair:** **Dr. Daniel A. Nussbaum** is a Professor at the Naval Postgraduate School in the Operations Research department in Monterey, California. His expertise is in cost/benefit analyses, lifecycle cost estimating and modeling, budget preparation and justification, performance measurement and earned value management (EVM), activity-based costing (ABC) and Total Cost of Ownership (TCO) analyses.



From December 1999 through June 2004, he was a Principal with Booz Allen Hamilton, providing estimating and analysis services to senior levels of the US Federal Government. He has been the chief advisor to the Secretary of Navy on all aspects of cost estimating and analysis throughout the Navy, and has held other management and analysis positions with the US Army and Navy, in this country and in Europe.

In a prior life, he was a tenured university faculty member.

Nussbaum has a BA in Mathematics and Economics from Columbia University, and a PhD in Mathematics from Michigan State University. He has held post-doctoral positions in Econometrics and Operations Research, and in National Security Studies at Washington State University and Harvard University.

He is active in professional societies, currently serving as the President of the Society of Cost Estimating and Analysis. He has previously been the VP of the Washington chapter of INFORMS, and he has served on the Board of the Military Operations Research Society.

He publishes and speaks regularly before professional audiences.

Finally, he is married, has two children and four grandchildren.

---



# A Non-simulation Based Method for Inducing Pearson's Correlation between Input Random Variables

---

**Presenter: Eric R. Druker** graduated from the College of William and Mary with a BS in Applied Mathematics in 2005, concentrating in both Operations Research and Probability & Statistics with a minor in Economics. He is employed by Northrop Grumman as a Technical & Research lead. He performs cost and risk analysis on several programs within both the Intelligence and DoD communities. He was a recipient of the 2005 NGIT President's Award for his work on Independent Cost Evaluations, during which he helped develop the risk process currently used by NGIT's ICE teams. As a member of Northrop Grumman's ICE working group, he has helped shape the cost and risk practices used on independent cost estimates and evaluations across the corporation. In addition to SCEA conferences, Druker has also presented papers at the Naval Postgraduate School's Acquisition Research Symposium, DoDCAS and the NASA PM Challenge. He has also performed decision tree analysis for NG Corporate law and built models for Hurricane Katrina Impact Studies and Schedule/Cost Growth determination.

Eric R. Druker  
Technical/Research Lead—Northrop Grumman IT (TASC)  
4584 Emerald View Ct.  
Eureka, MO 63025  
Office: (636) 587-2624  
Mobile: (703) 408-0589  
Email: [Eric.Druker@ngc.com](mailto:Eric.Druker@ngc.com)

**Richard L. Coleman** is a 1968 Naval Academy graduate. He received an MS with Distinction from the US Naval Postgraduate School and retired from active duty as a Captain, USN, in 1993. His service included tours as Commanding Officer of USS Dewey (DDG 45), and as Director, Naval Center for Cost Analysis. He has worked extensively in cost, CAIV, and risk for the Missile Defence Agency (MDA), Navy ARO, the intelligence community, NAVAIR, and the DD(X) Design Agent team. He has supported numerous ship programs including DD(X), the DDG 51 class, Deepwater, LHD 8 and LHA 6, the LPD 17 class, Virginia class submarines, CNN 77, and CVN 21. Coleman is the Director of the Cost and Price Analysis Center of Excellence and conducts Independent Cost Evaluations on Northrop Grumman programs. He has more than 65 professional papers to his credit, including five ISPA/SCEA and SCEA Best Paper Awards and two ADoDCAS Outstanding Contributed Papers. He was a senior reviewer for all the SCEA CostPROF modules and lead author of the Risk Module. He has served as Regional and National Vice President of SCEA and is currently a board member.

Richard L. Coleman  
Sector Director—Northrop Grumman Cost/Price Analysis Center of Excellence  
15036 Conference Center Dr.  
Chantilly, VA 20151  
Office: (703) 449-3627  
Mobile: (703) 615-4482  
Email: [Richard.Coleman@ngc.com](mailto:Richard.Coleman@ngc.com)

**Peter J. Braxton** holds an AB in Mathematics from Princeton University and an MS in Applied Science (Operations Research) from the College of William and Mary. He has worked to advance the state of knowledge of cost estimating, Cost As an Independent Variable (CAIV), Target Costing, and risk analysis on behalf of the Navy Acquisition Reform Office (ARO), the DD(X) development program, and other ship and intelligence community programs. He has co-authored several professional papers, including ISPA/SCEA International Conference award-winners in CAIV (1999) and Management (2005). Braxton served as managing editor for the original development of the acclaimed Cost Programmed Review of Fundamentals (CostPROF) body of



knowledge and training course materials and is currently undertaking to lead a large team of cost professionals in a comprehensive update thereof. He serves as SCEA's Director of Training and was recently appointed a Northrop Grumman Technical Fellow.

Peter J. Braxton  
Technical Fellow—Northrop Grumman IT (TASC)  
15036 Conference Center Dr.  
Chantilly, VA 20151  
Office: (703) 961-3411  
Mobile: (703) 944-3114  
Email: [Peter.Braxton@ngc.com](mailto:Peter.Braxton@ngc.com)

---

## Abstract

Several previously published papers have cited the need to include correlation in risk-analysis models. In particular, a landmark paper published by Philip Lurie and Matthew Goldberg presented a methodology for inducing Pearson's correlation between input/independent random variables. The one subject, absent from the paper, was a methodology for finding the optimal applied correlation matrix given a desired outcome correlation. Since the publishing of the Lurie-Goldberg paper, there has been continuing discussion on its implementation; however, there has not been any presentation of an optimization algorithm that does not involve the use of computing-heavy simulations. This paper reviews the general methodology used by Lurie and Goldberg (along with its predecessor papers) and presents a non-simulation approach to finding the optimal input correlation matrix, given a set of marginal distributions and a desired correlation matrix.

## Introduction

The Complete Correlation Algorithm (CCA) developed by Northrop Grumman and recently implemented in NG developed risk models is a product of more than two years of research and development. Several previously published papers have cited the need to include correlation in risk-analysis models; however, none present an optimization algorithm that does not involve the use of computing-heavy simulations. In particular, a landmark paper published by Philip Lurie and Matthew Goldberg (1998) presented a methodology for inducing Pearson's correlation between input random variables. This paper reviews the general methodology used by Lurie and Goldberg (along with its predecessor papers) and presents the Druker Algorithm: a non-simulation approach to finding the optimal input correlation matrix given a set of marginal distributions and a desired correlation matrix.

The CCA was deliberately created bearing in mind identified environmental factors that prevent easy implementation of commercially available models. No one on the team had any experience implementing correlation into Monte Carlo simulations beyond the use of COTS programs, such as @Risk™ and Crystal Ball™. To determine the best development method, the following factors were considered:

1. The Northrop Grumman risk models need to be of an easily transferable electronic size, as the models are often shared via email or network drives.
2. A diverse group of users must be able to run the software in a variety of work environments; Microsoft Office is the only platform that is transferable to all parties. Users include risk practitioners, program managers and members of pricing





organizations; locations include unclassified and classified Northrop Grumman facilities, unclassified and classified customer facilities and home offices.

3. Custom implementations are frequent; much of NGIT-TASC risk work requires risk simulations to be built into pre-existing cost and price models. These models are generally limited to Microsoft Excel and Access; however, Web-based platforms are not unheard of.

The above concerns drove the decision to use Visual Basic source code to develop *the CCA*.

Initially, the development was focused on an algorithm that could induce Pearson's correlation between typical distributions in risk analysis: Bernoulli (discrete), Triangular, Normal and Log-Normal. By limiting the problem to the most-common applications, in theory, the solution should have been easier to find. While attempting to ascertain the maximum correlation between any two Bernoulli distributions, however, the general solution was uncovered. The resulting algorithm induces Pearson's correlation between any set of random variables (while still preserving the marginal distributions) using the Lurie-Goldberg Method and without the use of simulation to find the optimal applied correlation matrix.

The *CCA* is a compilation of multiple algorithms (each named for their main author(s)) from several sources: existing papers, public source code and internally-developed code. Most of the algorithms used were taken from a variety of existing papers. Although these papers all provided complete algorithms, they sometimes lacked details in how to accomplish key steps; in cases such as these, gaps were filled with open-source code solutions. The optimization of the applied correlation matrix, the last step in the correlation algorithm, was developed entirely by the Northrop Grumman Team.

## Definitions and Assumptions

### Matrix Definitions:

1. **Consistent Correlation Matrix**—Consistent Correlation matrices have diagonal entries equal to 1.0, all other entries between [-1, 1] are symmetric and positive definite. Consistency is necessary for a viable correlation matrix, but a Consistent Correlation Matrix may not necessarily be viable given the **Parent Distributions**.
2. **Input Correlation Matrix (I)**—The user-inputted correlation matrix. This matrix may or may not be a consistent correlation matrix.
3. **Adjusted Correlation Matrix (L)**—The **Input Correlation Matrix** adjusted to be a **Consistent Correlation Matrix**. This matrix will, by definition, be positive definite. Additionally, the adjusted matrix will be viable as correlations between various distributions of random variables will be achievable. When (**L**) is generated, the differences between (**I**) and (**L**) are minimized.
4. **Applied Correlation Matrix (A)**—The correlation matrix used by the *grand algorithm* to generate correlated random number draws. This matrix may be the same, or very different from, the **Adjusted Correlation Matrix**; the extent of the differences will depend on the random variables to be correlated.
5. **Optimal Applied Correlation Matrix (A')**—The Applied Correlation Matrix optimized using the Lurie-Goldberg Method.



6. **Outcome Correlation Matrix (O)**—The correlation matrix of the simulated variables following the simulation run. The goal of the *grand correlation algorithm* is for (O) to be identical to (L).

#### Other Definitions:

1. **Parent Distribution**—The distributions correlated for use in the simulation. The distributions are simulated using the Inverse CDF technique. The goal is to induce a desired correlation between these distributions.
2. **Pearson's Correlation**—A parametric statistic that measures the *strength and direction of a linear relationship between two random variables* ("Correlation," 2008).
3. **Spearman's Rank Correlation**—A non-parametric statistic that measures the monotonicity of a function without making any assumptions as to the distribution of the variables.
4. **Eigenvalues**—A scalar (L) associated with a matrix such that if (A) is a matrix and (X) is a vector,  $AX = LX$ . The vector (X) is known as the **Eigenvector** that corresponds to the **Eigenvalue** (L).

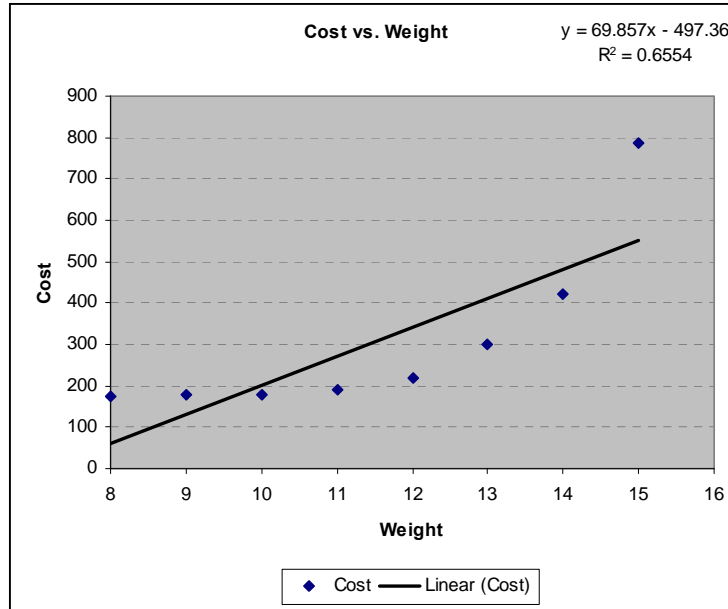
#### Assumptions:

1. **Normal Distributions**—Any reference to the normal distribution, whether in a univariate or bivariate case, is assumed to be the Standard Normal distribution (Mean of 0, Standard Deviation of 1).

#### Pearson's vs. Rank Correlation

Most COTS risk tools use Spearman's rank correlation as a substitute for Pearson's correlation between parent distributions. Spearman's rank correlation (a non-parametric statistic) differs from Pearson's correlation (a parametric statistic) in that it measures the monotony of a function, whereas Pearson's correlation measures the strength of the linear relationship between two functions (see Figure 1). Though studies have shown that, using the most common risk distributions, models using rank correlation yield similar results to those using Pearson's (Robinson & Salls, 2004), there is a distinct difference between the two. Although this paper will not detail all the differences between the two measures, a quick (and exaggerated) example is presented below. The *grand algorithm* supersedes the need to substitute for Pearson's correlation with Spearman's rank correlation.





<b>Pearson's Rho</b>	<b>0.81</b>
<b>Spearman's Rho</b>	<b>1.00</b>

**Figure 1. Pearson's vs. Spearman's Rank Correlation**

## Algorithm Overview

There are three main steps behind the *grand algorithm*. An outline of these steps follows, and the upcoming sections of this paper will review each individual step in detail.

1. Correct the **User-Input Correlation Matrix (I)**
  - a. Correct **I** so that it is consistent—both in terms of a general correlation matrix and the properties of the parent distributions being correlated.
  - b. Through these corrections, the Adjusted Correlation Matrix (**L**) will be generated.
2. Optimize the **Applied Correlation Matrix**
  - a. Find the **Optimal Applied Correlation Matrix (A')** such that when **A'** is run through the Lurie-Goldberg Method, the **Outcome Correlation Matrix (O)** is identical to **L**.
3. Correlate the Input Random Variables
  - a. Using **A'**, apply the Lurie-Goldberg Method to correlate the parent distributions.

For purposes of presenting the methodology, it is necessary to show how the input random variables are to be correlated before discussing how to find **A'**.

## Correcting the User-Input Correlation Matrix (Part I)

Giving users the ability to input their own correlation matrix allows for the possibility that the **User-Input Correlation Matrix (I)** may not be a viable correlation matrix. Correlation matrices, by definition, have diagonal entries of 1.0. All other entries between [-1, 1] are symmetric and are positive definite. The first step in inducing correlation between input random variables is checking whether **I** is a consistent correlation matrix. If it is not, it must be corrected that it is such.

The *Iman-Davenport Algorithm*, which is based on a paper by Ronald Iman and James Davenport (1982) is used to correct **I** in order to make it a consistent correlation matrix. While numerous other papers have been published describing methods to correct **I** such that it is altered as little as possible (Higham, 2002), the *Iman-Davenport Algorithm* is the most computationally efficient method the authors uncovered. Given that additional adjustment may be required based on the parent distributions being correlated; the resulting matrix is close enough to **I** to satisfy this requirement.

The algorithm corrects **I** in three main phases. First, the algorithm checks whether **I** is symmetric with diagonal entries of 1.0 and off-diagonal entries between [-1, 1]. If it is not, the user is prompted to re-input the matrix, correcting for the discrepancies.

Second, once the above conditions are satisfied, the algorithm checks whether **I** is positive-definite. One way to test this is to find the eigenvalues for **I** (positive-definite matrices have all positive eigenvalues). The paper referenced did not describe an approach for finding the eigenvalues of the matrix. After further research, the Jacobi Eigenvalue Algorithm was determined to be a sufficiently efficient way to evaluate a matrix's eigenvalues. As a result, the eigenvalues are produced as the diagonals of an otherwise zero-matrix. The Jacobi Eigenvalue Algorithm is computationally inexpensive and pre-existing source code was used in its implementation.

If all eigenvalues for **I** are positive and the other conditions have been satisfied, then **I** is a consistent correlation matrix. Otherwise, in the third phase, negative eigenvalues are changed to small, positive values (e.g., .000001). The diagonal matrix of adjusted eigenvalues is then multiplied by the associated matrix of eigenvectors (also produced using the Jacobi Eigenvalue Algorithm). That product is, in turn, multiplied by the inverse of the matrix of eigenvectors to arrive at a new matrix that is similar, but not equal to, **I**. Lastly, the diagonals are reset to 1.0 as they may have changed during the transformation. This third section of the algorithm is repeated until all eigenvectors of the adjusted matrix are positive. At this point, the user input matrix has been adjusted such that it is a consistent correlation matrix.

Though the **User-Input Correlation Matrix** is now a consistent correlation matrix, the transformation of **I** is not complete and the **Adjusted Correlation Matrix (L)** has not been determined. As will be shown later, depending on the parent distributions being correlated, there may be a maximum achievable correlation between any two of the variables. Determination of **L** will be covered later in the section: *Correcting the User-Input Correlation Matrix (Part II)*.



## Correlating Input Random Variables

In order to understand how the **Applied Correlation Matrix (A)** is to be optimized such that the **Output Correlation Matrix (O)** is identical to the **Adjusted Correlation Matrix (L)**, the method for correlating the parent distributions must first be discussed. It is a well-known fact that normal random variables can be correlated by multiplying a vector of uncorrelated normal random draws by the Cholesky decomposition<sup>36</sup> of the desired correlation matrix. The Lurie-Goldberg Method takes this one step further using normal random variates to generate correlated uniform random variates. These uniform random variates are then transformed via the inverse-CDF technique to generate draws from the desired parent distributions. In this method, although the correlations between the normal random draws are known, as these draws are transformed into other distributions, the correlations change. Hence, the core problem emerges: how can the **Optimal Applied Correlation Matrix (A')** be uncovered such that **O** matches **L**? Answering this question is key to implementing the Lurie-Goldberg Method. The authors have developed an algorithm that addresses this very question, without necessitating any runs of the simulation. Additionally, they have begun the process of optimizing this algorithm, finding heuristics that allow it to run with a minimal number of calculations.

## Implementation and Application of the CCA

The CCA's chief advantage is that it is non-recurring and its implementation requires no simulation. Furthermore, because the algorithm only requires looking at pairs of parent distributions, once the applied matrix has been found for a set of parent distributions, the algorithm must only be run when distributions are added or changed, and even then, only for the new/altered distributions. The algorithm also uses Pearson's correlation while COTS risk tools substitute Spearman's rank correlation.

The applications of the CCA reach beyond the Cost and Risk analysis community; this algorithm is useful anywhere there is a need to induce Pearson's correlation between input variables. For example, this algorithm can be applied to auto correlating, stock market projections in the financial arena and to traditional modeling and simulation situations when correlation is needed. The algorithm was designed with a focus on portability. Because the algorithm is coded with Visual Basic, it can be easily integrated in existing tools and models.

## List of References

Correlation. (2008). *Wikipedia*. Retrieved April 1, 2008, from <http://en.wikipedia.org/wiki/Correlation>

Iman, R., & Davenport J. (1982, June). *An iterative algorithm to produce a positive definite matrix from an "approximated correlation matrix" (With a Program User's Guide)*. Albuquerque, NM: Sandia National Laboratories.

Higham, N. (2002, July). Computing the nearest correlation matrix—A problem from finance. *IMA Journal of Numerical Analysis*, 22, 329-343.

---

<sup>36</sup> The Cholesky Decomposition Matrix of any matrix  $M$  is  $L$  such that  $M = LL^T$



Robinson, M., and Salls, W. (2004, June). *More on correlation accuracy in crystal ball simulations (or what we've now learned about Spearman's R in cost risk analyses)*. Remarks delivered at the 2004 SCEA Conference, Manhattan Beach, CA.

Goldberg, M. S., & Lurie, Philip M. (1998, February). An approximate method for sampling correlated random variables from partially-specified distributions." *Management Science*, 44(2).

**Open Source Code References:**

The Foxes Team, Italy—<http://digilander.libero.it/foxes>

Axel Vogt, Germany—[http://www.axelvogt.de/axalom/bivariateNormal\\_Series.zip](http://www.axelvogt.de/axalom/bivariateNormal_Series.zip)



# Application of Transaction Cost Economics to Capabilities-based Acquisition: Exploring Single Service vs. Joint Service Programs and Single Systems vs. System-of-Systems

---

**Authors:** **Dr. Diana Angelis**, Associate Professor, **John Dillard**, Senior Lecturer, **Dr. Raymond (Chip) Franck**, Senior Lecturer, **Dr. Francois Melese**, Professor, Defense Resource Management Institute, Naval Postgraduate School, **Dr. Mary Maureen Brown**, Associate Professor, University of North Carolina, Charlotte and **Robert M. Flowe**, Office of the Deputy Under Secretary of Defense (Acquisition & Technology), Software Engineering and Systems Assurance

---

## 1. Introduction

The US Department of Defense (DoD) is in the process of radical transformation—transformation to a national security strategy predicated on joint Service purchases and complex System-of-Systems (SoS) capabilities.<sup>37</sup> This paper contributes to a broader study that eventually needs to be conducted to evaluate the benefits and costs of increased reliance on joint Service SoS programs.

The DoD's increasing emphasis on joint Service SoS capabilities has created both opportunities and challenges for materiel acquisition. In terms of improving the *effectiveness* of warfighting capabilities, the opportunity exists for joint, interoperable, multi-function, multi-mission systems that leverage information dominance and improve decisions and outcomes by making US and coalition forces not only better informed, but more coordinated, faster and more adaptive. In terms of *efficiencies*, multiple opportunities exist for joint programs to cut “economic production costs”—for instance, by reducing duplication, by exploiting learning curves, and by achieving economies of scale and scope in manufacturing, and in operations and support activities (e.g., joint training and logistics).

However, there is a dark side. A key barrier needs to be overcome for the DoD to achieve the promises of joint Service SoS programs. This involves the challenge of “transaction (coordination and motivation) costs.” These are the less visible, but nonetheless significant, costs of negotiating, managing and monitoring transactions.

There are a variety of categories of joint Service programs. These range from relatively simple, single-system, single-Service programs to which other Services sign on to use the end product, to fully integrated, multi-Service SoS programs. Examples of the latter include the Joint Strike Fighter (JSF) and the Joint Surveillance Target Attack Radar System (JSTARS). Clearly, the latter (joint Service SoS) acquisitions are considerably more challenging than the former. The reason can be traced to greater interdependence, manifested in greater complexity and uncertainty.

---

<sup>37</sup> As defined in the DoD *Defense Acquisition Guidebook* (2004), an SoS is “a set or arrangement of systems that results when independent and useful systems are integrated into a larger system that delivers unique capabilities.” Joint Program Management is defined as “Any defense acquisition system [...] or technology program that involves formal management or funding by more than one DoD Component during any phase of a system's life cycle” (DAU, 2004, p.1). *DoD Directive 5000.1, The Defense Acquisition System*, dated 12 May 2003, indicates a policy preference for joint development programs over Component-unique development programs (USD(AT&L)).





Joint Service SoS acquisitions involve more stakeholders, multiple users and funding sources, divergent and competing requirements, and conflicting objectives that lead to difficult and contentious tradeoffs, diffused authority, negotiated budget arrangements, complex project management structures, etc. This increased interdependence is generally reflected in greater transaction costs: higher “coordination costs” from increased complexity and uncertainty, and higher “motivation costs” from greater asset specificity and limited market contestability.

The higher the transaction costs, the greater economic production cost efficiencies need to be to offset them. As recently emphasized by Melese, Franck, Angelis and Dillard (2007), if initial cost estimates focus exclusively on economic production costs and ignore transaction costs, the result can be systematic cost overruns.

According to a recent RAND study of major acquisition programs, the average cost overruns of weapon systems in the development phase ranged from 16% to 26%. Procurement cost growth over initial estimates averaged between 16% and 65%, while total weapon program cost overruns averaged from 20% to 54% (Arena, Leonard, Murray & Younossi, 2006).

Since the official “acquisition program baseline” (APB) estimates for these programs reflect the best current understanding of the cost, schedule, and performance objectives at the time the baseline is established (typically at Milestone B decisions), Congressional funding of these programs represents an implicit contract with the Executive Branch. When incomplete or unrealistic cost estimates lead to significant cost and schedule overruns relative to expectations established in the APB, administrative sanctions, such as statutory (Nunn-McCurdy<sup>38</sup>) unit cost breaches, can be triggered. In turn, these breaches can

---

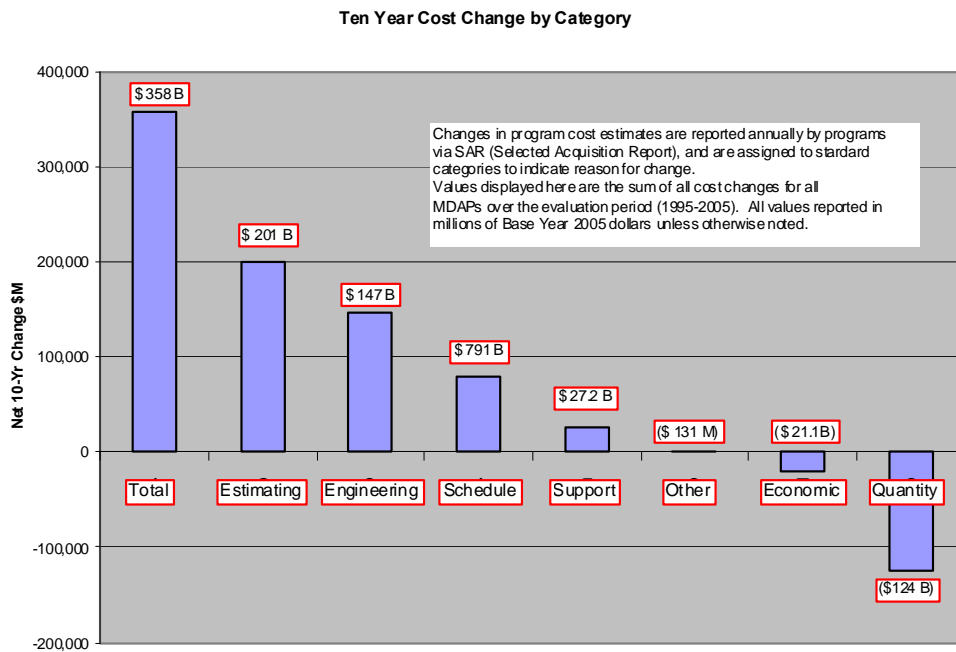
<sup>38</sup> Since the law was enacted in 1982, Title 10 USC Section 2433, a “Nunn-McCurdy” unit cost breach occurs when a major defense acquisition program experiences an increase of at least 15% in program acquisition unit cost or average procurement unit cost above the unit costs in the acquisition program baseline. Through 2006, the DoD had the ability to administratively change the acquisition program baseline for the purposes of unit cost reporting, and so was able to reduce the number of apparent Nunn-McCurdy breaches, despite apparent cost growth that would otherwise trigger the Nunn-McCurdy sanctions. In 2006, the Nunn-McCurdy law was amended. The FY 2006 *National Defense Authorization Act (NDAA)* severely restricted the DoD’s ability to change unit cost reporting criteria. As a result of this change, Nunn-McCurdy unit cost breaches are incurred at 15% (“Significant”), and 25% (“Critical”) above the current unit cost threshold. Additionally, a “Significant” Nunn-McCurdy breach is incurred at 30% of the Milestone B unit cost threshold, and a “Critical” Nunn-McCurdy breach is declared at 50% growth above the Milestone B unit cost threshold. Thus, the ability of the DoD to mask unit cost growth through changes to unit cost thresholds is restricted. The sanctions imposed by Congress on programs breaching Nunn-McCurdy criteria are noteworthy: For “Significant” breaches, the Service Secretary must notify Congress within 45 days of the report (normally program deviation report) upon which the determination is based (normally a program deviation report initiated when the Program Manager becomes aware of the breach). The program must submit a Selected Acquisition Report (SAR) with the required unit cost breach information. For “Critical” breaches, the Defense Secretary (usually delegated to the Under Secretary of Defense for Acquisition, Technology, and Logistics) must certify to Congress within 60 days of notification that:

- 1) the program is essential to national security,
- 2) there is no alternative which can provide equal capability at less cost,
- 3) the updated estimates of unit cost (calculated independently by the OSD Cost Analysis Improvement Group) are reasonable, and
- 4) the management structure is adequate to control unit cost going forward.



dramatically impact program execution; they also jeopardize relations between the Legislative and Executive Branches of government.

A study conducted by the DoD in 2007 to develop a business case for improving system cost estimating in the DoD (Brown, Flowe & Hamel, 2007b) examined the cost growth of all major defense acquisition programs (MDAPs) from 1995 to 2005 to determine the source and relative magnitude of cost growth and schedule breaches. See Figure 1.



Source SAR Data 1995-2005 All MDAPs

**Figure 1. Cost Growth by Category for All MDAPs 1995-2005**  
(Brown, Flowe & Hamel, 2007b)

As shown in Figure 1, the largest source of cost growth as reported in the Selected Acquisition Reports (SAR) is “Estimation.” This indicates that estimates made in establishing MDAP acquisition program baselines were often in error, and thus program costs appeared to grow despite very little change in the objective content of the program. This “Estimation” error accounted for approximately \$201 billion in apparent cost growth over the 10-year period examined across all major programs.

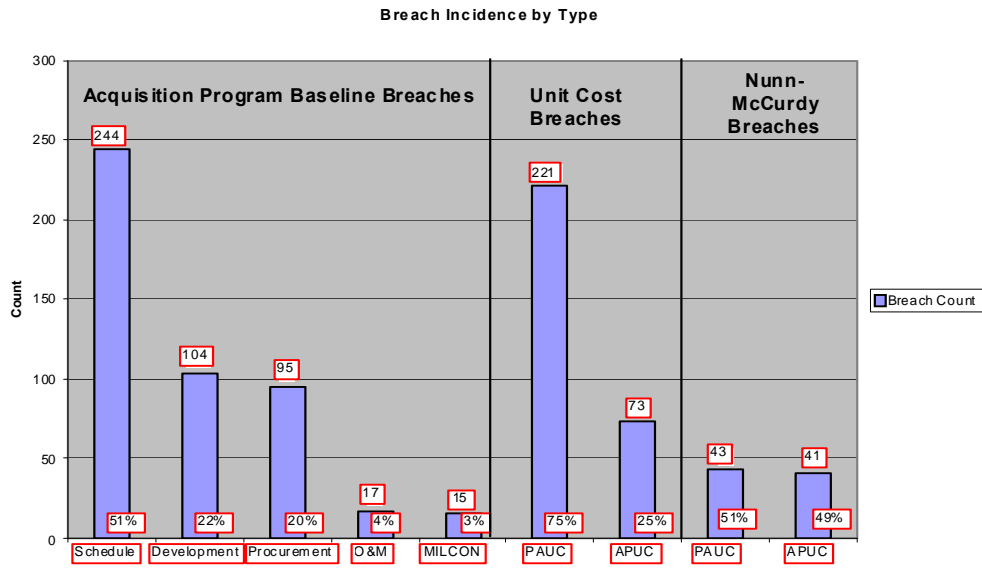
Figure 2 is a related analysis that examines the quantity and sources of breaches for 108 MDAPs over the same 10-year period (1995–2005). With respect to the Acquisition Program Baseline (APB), schedule breaches were the most common; occurring 244 times

---

Failure to certify within the 60-day timeframe will result in suspension of obligations for major contracts until 30 days of continuous session of Congress, beginning from the date of receipt of SAR/Certification.



over the 10-year period examined, suggesting that multiple schedule breaches is a relatively common occurrence in many programs.



Source SAR Data 1995-2005 All MDAPs

**Figure 2. Breaches Reported by SAR All MDAPs 1995-2005**  
(Brown, Flowe & Hamel, 2007b)

Development and procurement cost breaches occur with less frequency than schedule breaches, but still occur sufficiently frequently that on average, each MDAP can expect to have one of each. Program Acquisition Unit Cost (PAUC) breaches occur nearly as frequently as schedule breaches, indicating that the confluence of development and procurement cost increases conspire to increase unit costs at least 10% above that established by the APB. Nunn-McCurdy breaches are notably less common, suggesting that only about 20% of programs that breach their APB unit costs will grow substantially beyond that. Overall, the raw quantity of breaches indicate that expectations regarding costs and schedules are usually unmet, to the extent that for the 108 MDAPs examined, each breached on average more than twice for schedule and unit cost, and at least once for development cost.<sup>39</sup>

This paper investigates cost and schedule breaches in a subset of MDAPs that includes a sample of 84 programs, divided into “Joint Service” and “Traditional” (single Service) acquisition programs, and “Single System” and “System-of-Systems” (SoS) programs. (The data is available upon request from the authors.) The results reported in Appendix I suggest there is a statistically significant higher risk of cost and schedule breaches in SoS programs than in single system acquisition programs. Interestingly, while

<sup>39</sup> This is not to imply that every program was equally troubled. A subset of particularly troubled programs, approximately 30% of the total, breached in some way every year they reported.



“Joint Service” programs in general have a weak statistically significant greater risk of schedule (and RDT&E cost) breaches than “Traditional” (single Service) programs, there is no significant difference between the two in terms of Program Acquisition Unit Cost (PAUC) breaches or Average Procurement Unit Cost (APUC) breaches. (See Tables 1 & 2 in Appendix I.)

Based on our sample, SoS programs tend to take relatively longer and cost more than single system acquisitions. This preliminary empirical evidence of cost and schedule breaches suggests initial cost (schedule) estimates of SoS programs may not be adequately capturing transaction costs. In fact, since production cost breaches are significantly greater, the transaction costs experienced by SoS programs may be overwhelming any potential economic production cost savings (Melese et al., 2007). If this is indeed the case, then the anticipated warfighting benefits of SoS solutions need to be sufficiently large to compensate for the extra costs and schedule delays experienced by these programs.

Meanwhile, it appears that while “Jointness” contributes to schedule overruns, it only weakly contributes to development cost overruns, and by itself, does not explain production cost overruns. While our results suggest joint programs tend to breach their schedules relatively more often than single Service programs (“every event in a joint program takes longer [...] extra time needs to be included in the program schedule” (DAU, 2004, p. 20)), joint programs in our sample only experienced a few more cost breaches than single Service programs in the early development (RDT&E) stages. There does not appear to be any statistical difference in production cost breaches (PAUC or APUC) between joint Service and single Service programs.

One explanation for this is that the joint Service programs in the sample encompass a spectrum that includes both single systems and SoS, and that the complexity and uncertainty associated with SoS is so significant as to overwhelm any additional complexity and uncertainty that might be experienced by joint Service programs. Another possibility is that built-in checks and balances tend to offset the extra transaction costs of joint Service programs.

For instance, “joint programs require special attention to multi-service funding requirements and to acquiring the right mix of joint expertise for the source selection process”; indeed, “full consultation and coordination with the participating components” is required (DAU, 2004, pp. 12, 21). The ultimate outcome may be to help anticipate and mitigate the extra transaction costs, and to avoid requirements creep in production stages of the program. Guidance for joint program managers is designed to inhibit any changes in scope, stating that “substantive changes to [...] program documentation, such as the acquisition strategy or the contract [need to be] negotiated with the participating Components prior to making changes” (p. 12).

With weapon system investments expected to capture a significant, and perhaps growing, share of defense budgets, unprecedented attention has been devoted to clarifying the determinants of risk, failure, and success in the joint arena (Pracchia, 2004). The defense department’s apparent inability to avert or even predict adverse program outcomes such as cost and schedule breaches is not only a source of external criticism (GAO, 2006) and internal attention (Krieg, 2005), it has undermined confidence in the time-honored practices of program management and oversight.



To date, there is significant debate regarding the factors that influence the outcomes of programs. Thus, the search for root causes and potential solutions of program cost growth, schedule delay, and capability shortfall have received increased attention. To help explain potential pitfalls associated with joint programs, this study leverages “Transaction Cost Economics” (TCE), which has recently been applied to generate new insights into defense cost overruns (Melese et al., 2007).

## 2. System-of-Systems (SoS) and a Declining Acquisition Workforce

In 2003, the Joint Capabilities Integration and Development System (JCIDS) replaced the “Requirements Generation System” that had identified warfighter needs for nearly 30 years (recently updated in CJCS, 2007, May 1). Providing a new, substantive role for Combatant Commanders, the JCIDS process reflects a significant shift in the focus of defense programming toward joint system capabilities. But an emerging concern is that DoD technology investments are becoming increasingly concentrated in very large, very complex system-of-systems.

In several recent cases, the size and complexity of undertaking SoS programs has overwhelmed the DoD’s ability to effectively manage them. According to a recent Congressional Research Service report, “management and oversight of acquisition programs increases as the value of the program increases” (Chadwick, 2007, p. 12). The larger the program, “the more difficult it is to sustain communications among staff members. In general, if there are “n” people in a program, the potential number of pair-wise channels is  $n(n-1)/2$  [...] larger teams [...] have a greater chance of communications breakdown” (DAU, 2004, p. 16). *Ceteris paribus*, the bigger the program, the larger the transaction (coordination) costs.

Compounding the challenge was a steep decline in the professional acquisition workforce available to negotiate, manage, monitor and enforce contracts. The post-Cold War draw-down, and the Acquisition Reform initiatives of the mid 1990s saw dramatic declines in the defense acquisition workforce, with a corresponding “brain drain of organic government program management capability, particularly in specialized acquisition-related fields such as systems engineering.”<sup>40</sup> The combination of the dramatically increased size

---

<sup>40</sup> The consequences of this “brain drain” have been noted by Congress, such that HR1585 (bill as passed by the House and Senate) FY08 National Defense Authorization Act SEC. 852. DEPARTMENT OF DEFENSE ACQUISITION WORKFORCE DEVELOPMENT FUND stated as follows:

—Chapter 87 of title 10, United States Code, is amended by inserting after section 1704 the following new section: “§ 1705. Department of Defense Acquisition Work force Development Fund” (a) ESTABLISHMENT.—The Secretary of Defense shall establish a fund to be known as the “Department of Defense Acquisition Workforce Fund” (in this section referred to as the “Fund”) to provide funds, in addition to other funds that may be available, for the recruitment, training, and retention of acquisition personnel of the Department of Defense.

(b) PURPOSE.—The purpose of the Fund is to ensure that the Department of Defense acquisition workforce has the capacity, in both personnel and skills, needed to properly perform its mission, provide appropriate oversight of contractor performance, and ensure that the Department receives the best value for the expenditure of public resources.”



and complexity of SoS programs coupled with a reduced DoD acquisition workforce offers one explanation for adverse programmatic outcomes that can be informed by TCE (Krieg, 2005).

To compensate for its declining internal expertise, the DoD devised and increasingly relied upon external “Lead Systems Integrators” to manage complex programs. Based on several recent, highly publicized failed attempts to outsource the integration of complex systems to private “Lead Systems Integrators” (LSI), Congress passed HR 1585 for 2008 defense authorizations, which formally issues a “Prohibition on the Use of Lead Systems Integrators” (Sec. 802). This effectively brings what are considered to be “inherently governmental” responsibilities (such as Lead Systems Engineer, Lead Cost Analyst, Program Manager, Deputy Program Manager, Systems Architect) back into the public domain by 2011.<sup>41</sup>

To the extent the foregoing legislation drives the responsibilities and functions back into the public sector (versus simply reasserting Government oversight), it bears noting that vertically integrating the responsibility for systems integration within the DoD is not without

---

<sup>41</sup> **FY07 NDAA SEC. 820. GOVERNMENT PERFORMANCE OF CRITICAL ACQUISITION FUNCTIONS.**

(a) **GOAL.**—It shall be the goal of the Department of Defense and each of the military departments to ensure that, within five years after the date of the enactment of this Act, for each major defense acquisition program and each major automated information system program, each of the following positions is performed by a properly qualified member of the Armed Forces or full-time employee of the Department of Defense:

- (1) Program manager.
- (2) Deputy program manager.
- (3) Chief engineer.
- (4) Systems engineer.
- (5) Cost estimator.

(b) **PLAN OF ACTION.**—Not later than six months after the date of enactment of this Act, the Secretary of Defense shall develop and begin implementation of a plan of action for recruiting, training, and ensuring appropriate career development of military and civilian personnel to achieve the objective established in subsection (a). The plan of action required by this subsection shall include specific, measurable interim milestones.

(c) **REPORTS.**—Not later than one year after the date of the enactment of this Act and each year thereafter, the Secretary of Defense shall submit to the congressional defense committees a report on the progress made by the Department of Defense and the military departments toward achieving the goal established in subsection (a).

(d) **DEFINITIONS.**—In this section:

(1) The term “major defense acquisition program” has the meaning given such term in section 2430(a) of title 10, United States Code.

(2) The term “major automated information system program” has the meaning given such term in section 2445a(a) of title 10, United States Code (as added by section 816 of this Act).





its own set of risks. Transaction cost economics (TCE) suggests vertical integration leads to internal bureaucratic coordination and motivation issues. These include the risk of internal opportunistic behavior (costly lobbying for promotions or budgets), multi-tasking (“what gets measured gets done”), and sub-optimization (success achieved at lower levels at the expense of the overall success of the program).

To mitigate these internal transaction costs, Kelman (2005) emphasizes three key features of a “bureaucratic organization”: “the extensive use of rules, hierarchy, and specialization.” (p. 10). DoD procurement activities are governed by several sets of federal government rules/regulations. For contracting, the *Federal Acquisition Regulation (FAR)* applies to the entire federal government. The *Defense FAR Supplement (DFARS)* applies only to the DoD. A subordinate set of governing regulations, outlined in Component-unique *FAR Supplements*, apply to individual DoD Components. Still another set of regulations, the *DoD 5000 series*, pertains to the acquisition of materiel— derived from the 1977 *OMB Circular A-109, Major System Acquisitions*. Another layer of complexity is imposed by several provisions within Titles 10 and 40 of the US Code, which impose specific additional requirements for the procurement of information technology in general, and business systems in particular<sup>42</sup>.

While these bureaucratic structures are imposed to address transaction costs, some argue the “cure is worse than the disease,” in that the layers of often obscure and conflicting guidance introduce new transaction costs beyond what would have been experienced in their absence. These transaction costs can be experienced as delays in procuring needed operational capability, in which case the “discipline” of the regulated bureaucracy translates into a lack of agility that imposes “time to market” penalties.

In light of the competing requirements for governance mechanisms to mitigate transaction costs—arising from vertical integration versus requirements for acquisition agility and the dramatically increasing complexity of large-scale systems—acquisition policies and procedures are undergoing intense scrutiny for their ability to support joint capabilities (DAU, 2004, Chapter 1, “Joint Program Management Introduction”). Many other changes are underway in the acquisition arena. Recognizing that single system acquisition methods may not readily apply to joint SoS capability-based acquisition efforts, the search is on for a clearer understanding of how various acquisition strategies either support or impede joint efforts. Transaction Cost Economics (TCE) offers a valuable framework to guide the way forward.

---

<sup>42</sup> Notably, the *Clinger Cohen Act of 1996*, 40 USC §1401 et seq., and 10 USC § 2222, *Defense Business Systems: Architecture, Accountability, and Modernization*, establish specific requirements for procurement of information technology that, in several key respects, differ from the procurement of weapon systems and other major defense acquisition programs, the responsibility for which is established by 10 USC §133, *Under Secretary of Defense for Acquisition, Technology, and Logistics*. The *Clinger-Cohen Act* effectively establishes a separate “chain of command” for IT acquisition programs, which runs from the Director of the Office of Management and Budget to the DoD Chief Information Officer (CIO), established by 44 USC §3506 as the “Senior official of the Department of Defense” for IT matters.





### 3. Transaction Costs = Motivation Costs + Coordination Costs

In business, two costs are typically factored into strategic acquisition decisions: production costs and the costs of managing the transaction—or “transaction costs” (Coase, 1937). Conventional strategies tend to focus on economic production costs (input costs, learning curves, economies of scale and scope, etc.). TCE emphasizes another set of costs—coordination and motivation costs. Economic production (opportunity) cost advantages tend to guide companies to specialize in “core” activities in which they have a comparative advantage, and to “transact” with outside suppliers to acquire other goods and services. A key contribution of TCE is to formally introduce and fully reveal the nontrivial costs of managing those transactions.

Transaction costs include coordination and motivation costs, such as search and information costs, decision, contracting, and incentive costs, and measurement, monitoring, and enforcement costs. TCE predicts these costs will vary across weapon system acquisition programs to the extent there are differences in certain key characteristics of the transaction—complexity, uncertainty, frequency, and asset specificity—as well as market contestability, and the choice of governance (contracting, etc.) mechanisms. A central point from TCE is that the choice of contract, organization, and incentives, along with key characteristics of the transaction (complexity, uncertainty, frequency, and asset specificity) and market contestability, must be considered in order to obtain reliable cost estimates of joint programs (Melese et al., 2007).

One of the key insights of TCE is that capital (and human capital investments) that are specific to a transaction (e.g., made to support a joint program acquisition) can generate cost savings, but also carry the risk of increasing transaction costs from opportunistic behavior. The role of relation-specific investments (“asset specificity”) is an important consideration that needs to be anticipated and factored into any analysis of joint Service SoS programs.<sup>43</sup>

### 4. Motivation Costs: The Role of Asset Specificity

Having made a specialized investment in location, physical, human, or other specific assets, a supplier often becomes the most efficient provider, which is good from a production-cost perspective, but provides incentives for the supplier to look for opportunities to extract more from the transaction (perhaps by demanding steep prices for any modifications to the contract). After investments in specific assets are made, the relationship is transformed from a customer having the choice of a number of competing suppliers to a bilateral monopolistic relationship between a buyer and seller.

---

<sup>43</sup> Williamson (1996) identifies six types of asset specificity: 1) site, 2) physical asset, 3) human asset, 4) dedicated asset, 5) brand-name capital, and 6) temporal. These are specialized investments that generate high returns within a specific relationship, but offer little value outside it. Site specificity refers to the co-location of facilities to minimize inventory or production costs. Physical asset specificity refers to the use of customized assets such as specialized dies and equipment. Human asset specificity refers to firm-specific knowledge and skills (e.g., “specific” as opposed to “general” training). Dedicated asset specificity refers to additional investments in plant and equipment made to sell the extra output to a specific customer. Brand-name capital specificity refers to investments in reputation. Temporal asset specificity refers to investments that facilitate timing and coordination of projects (e.g., investments in critical-path activities).



Similar to “sunk costs,” investments in relationship-specific assets (“asset specificity”) are potentially valuable, but can increase risks to both parties in a transaction (Klein, Crawford & Alchian, 1978). Close-in bilateral bargaining (a principal-agent type game) replaces the competitive marketplace. This entails a transformation of the supplier from competitive bidder (prior to source selection) to monopoly supplier (after source selection), especially if there are no close substitutes. Accordingly, the customer (government) is now vulnerable to “opportunistic behavior” from the supplier.

Unforeseen contingencies, combined with newly inelastic demand, may prompt the supplier to extract more of the surplus created in the relationship.<sup>44</sup> In this case, suppliers can exploit their power in the relationship by renegotiating a basic agreement to their advantage, otherwise threatening to dissolve the agreement. The TCE literature refers to this as a “hold-up”<sup>45</sup> (Klein, Crawford & Alchian, 1978).

Conversely, a supplier (defense contractor) that makes specific investments in assets that are only valuable in the context of the relationship with a specific customer (government), can find itself vulnerable to any changes in demand from that customer (i.e., the supplier suffers from “demand uncertainty”). Given the government is the only buyer (or one of only a few) of joint SoS weapon systems, and given its limited ability to commit as a result of the annual nature of most budgetary processes, defense industry sellers often face a monopsony buyer that cannot make credible multi-year commitments. This leads to sellers facing substantial demand uncertainty and the real risk of strategic renegotiation.

Whereas relation-specific investments can increase the total gains to both parties, the risk exists of opportunistic behavior; either party can hold up the other, for instance, by threatening to change the terms of the contract (e.g., the government’s sovereign right to terminate a contract for convenience as well as default). The danger is that if neither party feels it can recover the full costs of its investment in the relationship/transaction (say through

---

<sup>44</sup> Williamson (1975), Besanko, Dranove, Shanley and Schaefer (2000), and others have labeled the transition from one prospective buyer and many sellers to one buyer and one seller, or from competitive market to bilateral monopoly, as the “fundamental transformation.” To some extent, this transformation occurs after the completion of every military source-selection process.

<sup>45</sup> According to Besanko et al. (2000), a holdup problem arises when a party in a contractual arrangement exploits the other party’s vulnerability due to relationship-specific assets).



a continuation or renewal of the contract—“frequency”),<sup>46</sup> then efficiency-generating, specific investments will not be made, resulting in higher costs.<sup>47</sup>

It is important to note at this point that whereas TCE has traditionally examined the customer-supplier relationship in the context of a contractual arrangement, the domain of joint capabilities acquisition is distinctive (though not exclusively so) in the establishment of partnerships among government entities (such as between DoD Services or Agencies), as well as teaming arrangements among private-sector enterprises within the defense industrial base (e.g., product development contractors and their first- and second-tier suppliers). These internal relationships also incur transaction costs related to coordination and motivation costs, search and information costs, decision, contracting and incentive costs, etc. This notion is explored further below.

Whereas defense acquisition has traditionally focused on economic production costs, joint programs expose the DoD to the potentially greater costs of managing the relationship, and more importantly, to the risks of opportunistic behavior on the part of contracting partners—a critical “transaction cost.” Given the multiple competing stakeholders in a joint SoS acquisition, the principle of self-interest suggests all sides have incentives to behave opportunistically and may not necessarily have the motivation to cooperate to make cost-saving investments—particularly when specific assets are involved, and information is imperfect (incomplete or uncertain) and asymmetric.<sup>48</sup> Clarification of the risks of “opportunism” (i.e., motivation costs) is one of the key advantages of TCE.

If it turns out that joint Service SoS programs require a significantly greater ratio of specific assets to total investments, then this increases the risk of bilateral dependency and “hold-up.” Moreover, given the difficulty of writing complete contracts for joint SoS programs that will cover every contingency, with incomplete contracts the hold-up problem poses

---

<sup>46</sup> In terms of “frequency,” past experience with similar programs appears to have a significant impact on a supplier’s costs and capabilities. So, if source selection and strategic partnership decisions recognize this and clearly favor past performance, the acquisition process will be converted from a one-shot game into a repeated game, allowing suppliers to earn a return on their investment in reputation. In this way, increasing frequency through strategic partnerships and recurrent transactions can mitigate opportunistic behavior and build trust in the contracting relationship. By identifying key characteristics of transactions such as frequency, and fully understanding their implications, decision-makers could mitigate cost, schedule and performance breaches.

<sup>47</sup> Scope for opportunistic behavior may lead to adverse selection, choice of an (ex ante) inferior option (or technology), or moral hazard. Such scope increases risks that if a relationship-specific investment is made, the other party will exploit the terms of the contract to “hold them up.” For example, changes in specifications are frequently used by contractors as a reason to raise prices and profits under government contracts—especially when those investments by the contractor create barriers to the entry of competitors.

<sup>48</sup> In order to combat this tendency, and in the spirit of resolving the principal-agent problem, an interesting incentive clause is included by the US Air Force in its “National Polar-Orbiting Operational Environmental Satellite System.” When establishing top executives’ salaries and bonuses, the contract requires TRW’s corporate board to consider contract performance. By tying senior executive pay directly to contract performance, decision-makers can help align incentives, increase accountability and reduce cost overruns (Graham, 2003).



additional risks for the government—such as contractors charging excessively high prices for change orders, and strategic renegotiations.

## 5. Governance Issues

TCE suggests the degree of completeness of a contract is an optimizing decision by the parties involved, one that reflects tradeoffs between ex-ante investments in contract design and the risk of ex-post costs of opportunistic renegotiation. In reality, contracting offers an imperfect solution to opportunism. What may be required are additional governance mechanisms (rules and regulations, reputation mechanisms, termination agreements, government-furnished equipment, Government-owned, Contractor-operated (GOCO) facilities, warranties, etc.) to shift risks to safeguard and protect transaction-specific investments, settle disputes, and adapt to new conditions. Ex-ante efforts may also be necessary to screen for reliability and reputation (e.g., pre-award contract surveys of potential vendors). These structures can include anything from agreements to share and verify cost and performance information through incentive contracts, to the careful crafting of dispute-settlement mechanisms (e.g., alternate dispute resolution, proactive management councils, etc.). Among government entities in joint acquisition programs, memoranda of understanding or agreement (MOUs or MOAs)<sup>49</sup> reflect a “quasi contractual” relationship among ostensibly sovereign entities. The enforceability of these is always questionable, but they nevertheless serve to make the particulars of agreements among the parties explicit and provide both implicit and explicit dispute-resolution mechanisms to reduce the risk of hold-up.

In general, the less complex and uncertain a transaction, and the lower the requirement for specific assets, the easier it is to write an explicit contract that covers all contingencies. Also, the lower the administrative and enforcement costs of that contract, the lower the risk of hold-up. These favorable characteristics are more likely to exist in established, traditional (single Service), single system acquisition programs, and contribute to lower costs (or cost overruns), and better performance and schedules.<sup>50</sup>

---

<sup>49</sup> The Air Force F-35 Joint Strike Fighter (JSF) program featured elaborate memoranda of agreement among domestic and international partners to reduce the risk of hold-up. Despite these structures, the sovereignty of partner governments limited the enforceability of these instruments, and hold-ups did occur—notably when the legislatures of the partner governments imposed changes to the agreements articulated in the MOAs, upon which program plans were based. The consequential impact of program cost, schedule, and performance outcomes have not been fully characterized, but would be a worthwhile subject of future TCE research.

<sup>50</sup> If a transaction requires little in the way of specific assets (no hold-up problem), and involves a product or service that is: a) well-defined and homogeneous, b) easy to measure (limited complexity and mild information asymmetry), c) routinely used (recurring/frequent purchases), d) not subject to change (limited demand uncertainty), and e) is offered by competing suppliers, then there is little room for negotiation (price and performance are market-driven), and the marginal benefit of unproductive bargaining is near zero. With little room for bargaining over such routine and uncomplicated transactions, substantial production and transaction cost stability can be expected in the acquisition. Moreover, since administrative, incentive, and enforcement costs tend to be low for acquisitions in more contestable (competitive) markets, the marginal cost of engaging in the transaction is relatively smaller for the military, and there exists an incentive for the supplier to invest in the transaction that generates opportunities for cost savings. International competition for standard



Evidence uncovered by Bajari and Tadelis (2001) in construction contracts reveals that in cases in which a transaction is easy to define and measure (i.e., there is little complexity), and only a few minor changes are expected (i.e., there is little uncertainty), fixed-price type contracts tend to dominate. However, the more complex the transaction—the more difficult/costly it is to define and measure performance, and the more uncertain—the more likely it is that a change in the contract will be required, and the more severe the adversarial relationships experienced ex-post when fixed-price contracts are chosen. In the latter case, fixed-price type construction contracts often end in costly renegotiations—in which any surplus generated was dissipated in the course of those negotiations through unproductive bargaining and influence activities. Thus, *complexity* and *uncertainty* can force parties to turn away from fixed-price type contracts and towards cost-reimbursement type contracts (e.g., costs plus a award/incentive fee), and to rely heavily on reputation and other enforcement mechanisms to avoid ex-post opportunistic behavior that threatens to dissipate the gains generated by a transaction.

In reality, joint Service acquisition programs often involve highly interdependent, complex system-of-systems (SoS) that usually end up in a bilateral monopoly contractual setting.<sup>51</sup> In this case, assuming no specific assets are required, the outcome depends on the degree of contractual ambiguity governing the transaction, as well as on any administrative and enforcement costs involved. However, as complexity, uncertainty, and opportunism due to specific investments increase, so does the risk of hold-up and so do the coordination and motivation (transaction) costs required to measure, monitor, and govern both the internal relationships among the Components and the external relationship with the contractor. These less-favorable characteristics of joint SoS programs can discourage productive efforts and investments in both internal Component relationships and external contractor relationships, and thus contribute to more serious cost overruns, schedule breaches, and performance shortfalls.

## 6. Coordination Costs: Interdependency yields Complexity and Uncertainty

Interdependency is typically defined as the degree to which the performance of one activity (or system) relies on an external activity (or system) for its success (Thompson, 1967). Under conditions in which organizations are allowed to seek the most efficient path to

---

(off-the-shelf) commercial components of weapon systems might be an example. By unbundling large, complex weapons systems into sub-systems, decision-makers might reveal opportunities to enjoy the benefits of lower transaction costs and greater competition, leading to lower production costs. These favorable characteristics generally lend themselves to more accurate cost estimating.

<sup>51</sup> Many factors conspire to create this bi-lateral monopoly. On the buyer side, monopsony power partly derives from the fact the military value of most systems depends solely on their performance relative to the systems of adversaries. This is specific to a country and the defense environment it faces at a particular point in time, effectively making it the sole buyer of a highly differentiated product. The appearance of a superior alternative results in what might be termed military obsolescence. Response to new threats can require redesign during development, and modifications during the system's operational life. This cause-and-effect relationship conspires to reduce the number of buyers of a particular weapon system, since these weapon systems are often evolving products (spiral acquisition). Thus, in addition to technical uncertainty, there is a significant degree of demand uncertainty.





task accomplishment, interdependent relationships will be established as long as the benefits exceed the costs. Private entities typically make technology investments and seek interdependencies to achieve the benefits of synergy and economies of scale based on measurable effects on the “bottom line.” In contrast, government agencies are often guided and constrained by legislative requirements for cross-organizational integration to establish interdependent relationships. Consider, for example, the increased emphasis on “jointness” since the *Goldwater Nichols Department of Defense Reorganization Act of 1986*. The intent of this legislation was clearly to increase interoperability, and hence interdependency, in the DoD. Combined with recent reforms that reinforce joint solutions to defense capability needs (such as JCIDS) and that simultaneously encourage SoS, the result is increased interdependency reflected in increased complexity and uncertainty, and correspondingly higher coordination costs.<sup>52</sup>

For most systems, interoperability is pursued as a means to leverage the collective assets of various organizations located at different points along the value chain. For example, in the command and control (C2) process, military operations benefit when commanders can seek, synthesize, and disseminate several types of information derived from different organizations. Experts in a variety of areas must collaborate during the C2 process to effectively create and execute battle plans. These experts may come from different disciplines (or specialties), different branches of the military, or even different countries. In short, interoperable systems promote interdependent actions. In turn, increased interdependency is reflected in increased complexity and uncertainty and higher coordination costs.

*Complexity* is a key component of transaction costs. When advanced (immature) technologies are combined with systems integration challenges across diverse organizations in the scale of joint Service SoS programs, the resulting complexity leads to higher coordination costs. Marshall and Meckling (1962) were among the first to discover that variability in the size of cost-estimating errors in defense contracts could at least partly

---

<sup>52</sup> Interdependent activities are not new to the DoD or to government in general. However, what is new is the scale in which interdependent actions are applied. Prior to the information technology revolution of the 1990s, spatial and temporal distances tended to impede communication and the sharing of information among partners. Hence, tightly coupled activities were generally restricted to small groups of geographically co-located groups where coordination costs could be minimized. The advent of advanced information and communication technologies eroded many of the spatial and temporal barriers that once thwarted collaboration. The potential benefits of information-sharing enabled by interoperability were then quickly realized and became a major thrust for many organizations, the DoD included. Network externalities were increasingly recognized—the value of the network to individual participants increased with the number of participants connected to the network. This refers to “Metcalfe’s Law,” which proposes that the value of a network varies as the square of the number of users or “nodes.” The foundation of Metcalfe’s law is the observation that in a communications network with  $n$  members, each can make  $(n-1)$  connections with other participants. If all those connections are equally valuable, the total value of the network is proportional to  $n(n-1)$ , that is, roughly,  $n^2$ . The law was named in 1993 by George Gilder, publisher of the influential *Gilder Technology Report*. Like Moore’s Law, which states that the number of transistors on a chip will double every 18 to 20 months, Metcalfe’s Law is a rough empirical description, not an immutable physical law (information derived from Briscoe, Odlyzko & Tilly, 2006).



be attributed to technological complexity, with larger errors associated with greater technological advances sought in different systems.<sup>53</sup>

*Uncertainty* is another key component of transaction costs. The reconciliation of competing requirements of different players in joint programs can lead to design changes and implementation challenges (demand uncertainty). Similarly, the “free rider problem” (in which none of the players want to sacrifice their budgets to cover costs that might benefit others), combined with changes in Congressional priorities (political uncertainty), can lead to funding instability (budget uncertainty). Besides demand, political, and budget uncertainty, joint programs face measurement uncertainty, technological uncertainty, supplier performance uncertainty, etc.<sup>54</sup>

An interesting avenue for future research would be to investigate if increased emphasis on “jointness” since the *Goldwater Nichols Department of Defense Reorganization Act of 1986* or the advent of the JCIDS in 2003 has increased the complexity and uncertainty of joint programs relative to others and, consequently, raised coordination and motivation costs. The possibility exists that other characteristics inherent in many joint programs might offset these higher transaction costs.

On the one hand, a joint program manager that manages a program that is technologically mature, that does not require strict military specifications, in which funding and requirements are relatively stable, and where a contestable market exists for the product or service, may in fact experience lower transaction costs. On the other hand, if the program is facing immature technologies, rigid specifications, funding and requirements instability, and monopolistic suppliers, joint program managers and other key decision-makers should recognize the potential for high transaction costs and opportunistic behavior.

---

<sup>53</sup> Adler (1995) examines the complex and interdependent relationship between product design and manufacturing, describing four possible governance mechanisms to improve coordination (standards, schedules, mutual adaptation and teams). McNaugher (1989) provides evidence that costs rise rapidly with system complexity, as does the variance of costs around expected costs (p. 128). Consider the increase in complexity in the US Navy’s new Littoral Combat Ship (LCS) class, which has experienced a 128% cost growth and which was designed to avoid costs through smaller crews (substituting capital for labor). It is unclear whether the substantial increase in transaction costs and scope for opportunism introduced with the increased complexity (capital investment in complex onboard systems) justifies the anticipated labor-cost savings.

<sup>54</sup> A dynamic programming model by Womer & Terasawa (1989) finds that under demand uncertainty, a rational defense contractor must prepare for various contingencies, and will, for example, restrict investments in specific assets, which drives costs higher than they would be if demand were certain. This tends to increase information and contracting costs, and as the authors demonstrate, threatens investments in specific assets. The authors show that the higher the probability the contract will be canceled, the less the contractor will invest in capital equipment (relation-specific investments), which results in relatively more labor-intensive production, raising costs. Thus, demand uncertainty increases contracting costs and also raises issues related to asset specificity. Under demand uncertainty, the rational contractor will restrict investments in specific assets (such as capital tooling or specialized expertise), unless they are reasonably sure to recover these costs via overhead. The allowability of “Facilities Capital Cost of Money” as an expense is a mechanism by which the Government reduces the risk to the contractor by allowing recovery of costs associated with specific capital assets (buildings, tooling, etc.) through overhead. Critics argue this encourages Defense contractors to over-capitalize, which increases costs DoD-wide.





## 7. Conclusion

Transaction Cost Economics (TCE) suggests investigating the specific characteristics of transactions that make up joint Service programs (like SoS) could help anticipate (and perhaps mitigate) cost and schedule breaches. Since increases in interoperability/interdependence tend to increase complexity and uncertainty, and complexity and uncertainty increase coordination and motivation costs, it is likely that cost and schedule breaches partly depend on decisions regarding the extent of bundling or unbundling of the many interdependent parts of joint systems,<sup>55</sup> and on the particular phase of development or production of those weapon systems.

Historically, fixed-price contracts are usually prescribed in later stages of product development when complexity and uncertainty have been resolved, and the contract is complete. In contrast, cost-reimbursement contracts are usually prescribed in earlier stages of product development when complexity and uncertainty have not been resolved, and the contract is incomplete.<sup>56</sup> Today cost-reimbursement contracts are phased out, and fixed-price contracts phased in, as complexity and uncertainty issues are resolved. However, complexity and uncertainty must be characterized in the context of TCE for this strategy to succeed. Note that while these prescribed contracts focus on the characteristics of *complexity* and *uncertainty*, often overlooked is the vital role of *asset specificity*—a key component reflected in the motivation cost component of transaction costs.

The main strategy of reducing cost and schedule breaches is employed to identify ways to cut coordination and motivation costs. Specific recommendations include: a) reducing complexity by investing in a more complete contract—e.g., setting realistic baselines (entailing higher search and information costs) or using more mature technologies (recently emergent in acquisition policies); b) reducing uncertainty through multi-year contracts (reducing demand uncertainty) or investing in a more complete contract (reducing relationship uncertainty); c) increasing measurement (CAIG) and monitoring (GAO) of performance and both production and transaction costs to reduce information asymmetries and the associated risks of moral hazard and adverse selection; d) placing credible deterrents to bad behavior in place—such as penalty clauses, warranties and bonding; e)

---

<sup>55</sup> For instance, an extremely complex interoperable system is envisioned for the Coast Guard's new "integrated deepwater system program." The system is intended to include cutters and small boats, a new fleet of fixed-wing aircraft, a combination of new and upgraded helicopters, and land- and cutter-based unmanned aerial vehicles (UAVs)—all linked with Command, Control, Communications and Computers, Intelligence, Surveillance and Reconnaissance (C4ISR) systems and supported by integrated logistics. According to a recent Coast Guard press release (2007, June 25), "Deepwater is a 25-year, \$24 billion effort that will produce more than 91 new cutters; 195 new aircraft" and C4ISR equipment. The lead systems integrator is a joint venture between Lockheed Martin and Northrop Grumman that has recently been in the news for major cost overruns, schedule slippages, and quality issues—the latter involving several modified ships that were determined un-seaworthy.

<sup>56</sup> "Complexity" and "technological uncertainty" (as opposed to "demand uncertainty") are usually correlated. Ignorance about what buyers want and what contractors can do result in large up-front search and information or Research and Development (R&D) costs. R&D is similar to a real option in the sense that real options models are learning models (Kogut & Kulatilaka, 2001). The problem that gives rise to high transaction costs in the case of complex weapon systems is that this characteristic of the transaction leads to market failure (missing markets). From a TCE perspective, the classic market failures—natural monopoly, negative externalities, public goods, etc.—have information analogues: missing markets, adverse selection, and moral hazard.



using multi-year contracts to gather information and to reward good reputations (Kelman, 1990); f) mitigating opportunistic behavior introduced by asset specificity through careful use of incentives, proper bundling (or task-partitioning) of joint programs, and strategic investments in government-furnished equipment or government-owned and contractor-operated assets; and finally g) increasing market contestability through investments in real options (e.g., government-controlled standby capacity—credible threat of vertical integration, or second sourcing—credible threat of entry).<sup>57</sup>

We believe any evaluation of joint Service—and particularly SoS—acquisition programs would benefit from an analysis of the characteristics of the corresponding bundles of transactions through the lens of TCE. An inspired effort to collect and analyze data guided by TCE (as described in this paper) could help DoD decision-makers to anticipate and mitigate cost and schedule breaches and to avoid future performance shortfalls.

## List of References

- Adler, P. (1995). Interdepartmental interdependence and coordination: The case of the design/manufacturing interface. *Organization Science*, 6(2), 147-167.
- Anton, J., & Yao, D. (1987). Second sourcing and the experience curve. *RAND Journal of Economics*, 18(1), 57-75
- Arena, M., Leonard, R., Murray, S., & Younossi, O. (2006). *Historical cost growth of completed weapon system programs*. RAND Technical Report. Santa Monica, CA: RAND.
- Bajari, P., & Tadelis, S.. (2001). Incentives versus transaction costs: A theory of procurement contracts. *RAND Journal of Economics*, 32(3), 387-407.
- Besanko, D., Dranove, D., Shanley, M., & Schaefer, S. (2000). *Economics of strategy* (2nd ed.). New York: Wiley.
- Brown, M., & Flowe, R. (2005, April-July). Joint capabilities and system-of-systems solutions. *Defense Acquisition Review Journal*, 12(2), 139-153.
- Brown, M., Flowe, R., & Hamel, S. (2007a). *Developing a business case for improving system cost estimating in DoD*. Unpublished manuscript.

---

<sup>57</sup> Since full-scale competition can involve duplicating high fixed costs and can require significant investments in specific assets, reliance on multiple sources is often prohibitively costly. Instead, duplicative supply has often been a way to hedge against technical uncertainty. For example, in the crash effort to develop ICBMs, two fully duplicative, concurrent programs were used to cut lead times—the Atlas and Titan projects. In more limited attempts to secure competition, parallel efforts can be applied in early stages of acquisitions (such as in systems development), with production then being allocated to a single source (“fly before you buy”). In practice, however, the greater the degree of asset specificity and fixed costs required in these design competitions, the less effective they are; indeed, knowledge is not easily transferred and close integration is needed between design and production. As witnessed in the Air Force’s F-22 program (GAO (2006) reports 200% cost overruns), the bulk of costs in most programs occur in the post-design stages. The threat of second sourcing (turning to another supplier) may be one way to inject discipline into the supply process. But if this threat is perceived by the seller to increase the risk of opportunistic behavior by the government buyer, then this added risk will raise the initial bids. Assuming effective competition existed for the initial contract, program managers cannot gain overall efficiency by using such tactics (Anton & Yao, 1987). Another possibility is inter-generational competition, or to inject some competition between a new system and its predecessor. The extension of existing systems provides some insurance against delays in the availability of the next-generation systems.



- Brown, M., Flowe, R., & Hamel, S. (2007b). The acquisition of joint programs: The implications of interdependence. *CrossTalk—The Journal of Defense Software Engineering*, 20(5), 20-24.
- Briscoe, B., Odlyzko, A., & Tilly, B. (2006, July). Metcalfe's Law is wrong. *IEEE Spectrum*. Retrieved April 8, 2008, from <http://spectrum.ieee.org/print/4109>
- Chadwick, S. (2007, June 20). *Defense acquisition: Overview, issues and options for congress*. Washington, DC: Congressional Research Service.
- CJCS. (2007, May 1). *Joint capabilities integration and development system* (CJCSI 3170.01F). Washington, DC: Author.
- DAU. (2004). *Joint program management handbook* (3rd. ed.). Ft. Belvoir, VA: DAU Press.
- DAU, DoD. (2006, July-August). DoD releases selected acquisition reports. News Release on April 7, 2006. *Defense AT&L Magazine*, 66-67.
- GAO. (2006). *Best practices: Better support of weapon system program managers needed to improve outcomes* (GAO-06-110). Washington, DC: Author.
- Graham, R. (2003). *The transformation of contract incentive structures*. *Acquisition Review Quarterly*, 10(Summer), 235-259.
- Kelman, S. (1990). *Procurement and public management*. Washington, DC: The American Enterprise Institute Press.
- Kelman, S. (2005). *Unleashing change: A study of organizational renewal in government*. Washington, DC: Brookings Institution Press.
- Klein, B., Crawford, R., & Alchian, A. (1978). Vertical integration: Appropriable rents and the competitive contracting process. *Journal of Law and Economics*, 21(2), 279-326.
- Kogut, B., & Kulatilaka, N. (2001). Capabilities as real options. *Organization Science*, 12(6), 744-758.
- Krieg, K. (2005, April 20). *Defense reforms*. Washington, DC: Library of Congress. Retrieved April 8, 2008, from [http://www.globalsecurity.org/military/library/congress/2005\\_hr/050421-krieg.pdf](http://www.globalsecurity.org/military/library/congress/2005_hr/050421-krieg.pdf)
- Marshall, W., & Meckling, W. (1962). Predictability of the costs, time and success of development. In R. Nelson (ed.), *The rate and direction of inventive activity: Economic and social factors* (pp. 461-475). Princeton, NJ: Princeton University Press.
- McNaugher, T. (1989). *New weapons, old politics: America's military procurement muddle*. Washington, DC: Brookings Institution Press.
- Melese, F., Franck, R., Angelis, D., & Dillard, J. (2007). Applying insights from transaction cost economics to improve cost estimates for public sector purchases: The case of U.S. military acquisition. *International Public Management Journal*, 10(4), 357-385.
- Pracchia, L. (2004, April). Improving the DoD software acquisition processes. *Crosstalk: The Journal of Defense Software Engineering*, 17(4), 4-7.
- Thompson, J. (1967). *Organizations in action: Social science bases of administrative theory*. New York: McGraw-Hill.
- US Coast Guard. (2007, June 25). *Coast Guard announces new contract for integrated Deepwater System program*. Press Release. Washington, DC: Author. Retrieved April 10, 2008, from <http://www.piersystem.com/go/doc/786/162067/>.
- USC. (1982). Title 10, Chapter 2433. Washington, DC: US Government Printing Office.
- USC. (2006a, January 2). Title 10, §133, *Under Secretary of Defense for Acquisition, Technology, and Logistics*. Washington, DC: US Government Printing Office.
- USC. (2006b, January 2). Title 10, § 2222, *Defense business systems: Architecture, accountability, and modernization*. Washington, DC: US Government Printing Office.



- USC. (2007). Title 10, *FY 2007 National Defense Authorization Act*, Section 820, *Government performance of critical acquisition functions*. Washington, DC: US Government Printing Office.
- USD(AT&L). (2003, May 12). *The defense acquisition system* (DoD Directive 5000.1). Washington, DC: Author.
- Williamson, O. (1975). *Markets and hierarchies: Analysis and antitrust implications*. New York: Free Press.
- Williamson, O. (1996). *The mechanisms of governance*. New York: Oxford University Press.
- Womer, N., & Terasawa, K. (1989, December). The effect of defense program uncertainty on cost, schedule, and capital investment. [\*Journal of Productivity Analysis\*, 1\(3\)](#), 193-228. Springer, Netherlands.
- United States Code. Title 10, Chapter 87, FY08 National Defense Authorization Act. SEC. 852. '§ 1705 Department Of Defense Acquisition Workforce Development Fund.

## APPENDIX I

The 84 DoD weapon system programs first divided into “Single Service” and “Joint Service” programs by Brown, Flowe & Hamel (2007b) were further divided into either “single system” or “system-of-systems” (SoS) programs. (Data available upon request.) The SoS designator was used as a proxy for complexity. Of course, SoS programs are not necessarily joint Service programs. For example, an aircraft carrier qualifies as SoS, but is managed by a single service. Another example is the F-22 managed exclusively by the Air Force. Of course, “single systems” can also qualify as joint programs if they are either managed or procured by more than one service. The tests below focused on four categories of breaches: Schedule, RDT&E, Program Acquisition Unit Cost (PAUC), and Average Procurement Unit Cost (APUC).

Because the subdivided samples were not normally distributed, we ran a Kruskal-Wallis (H) test to determine if there was a significant difference in the mean ranks of the groups, testing Single Service vs. Joint Service and Single Systems vs. System-of-Systems (SoS). The H test is particularly robust as it does not make any assumptions about the underlying distribution of the samples.



**Table 1. Kruskal-Wallis (H) Test**

<b>Variable</b>	<b>Single System</b>	<b>System of Systems</b>		<b>Single Service</b>	<b>Joint Service</b>	
	Mean Rank (n=39)	Mean Rank (n=45)	p-value	Mean Rank (n=58)	Mean Rank (n=26)	p-value
Schedule breaches	34.36	49.56	0.0039	38.56	51.31	0.0246
RDT&E breaches	32.44	51.22	0.0002	39.34	49.56	0.0631
PAUC breaches	39.14	45.41	0.2244	41.70	44.29	0.6418
APUC breaches	39.60	45.01	0.2633	42.09	43.42	0.7977

**Variables and Definitions**

<b>Variable</b>	<b>Variable Definition</b>
Schedule Breach	When schedule exceeds most recent APB schedule estimate by six months.
RDT&E Breach	When the program’s research, development, test, and evaluation costs exceed 15%.
PAUC Breach	When the Program Acquisition Unit Cost exceeds the most recent Acquisition Program Baseline threshold by 15%. This is a congressionally reportable breach.
APUC Breach	When the Average Procurement Unit Cost exceeds the most recent APB threshold by 15%. This is a congressionally reportable breach.

The results reported in Table 1 suggest significantly greater schedule breaches and RDT&E cost breaches in SoS than in Single Systems, with a weaker result for Joint Service vs. Single Service. The null hypothesis is that there is no significant difference.

The results overall are consistent, but somewhat weaker considering the difference in the average number of breaches between development and production programs using a Mann-Whitney (U) test (which also makes no assumptions about the underlying distribution of the samples). We examined the difference in mean ranks for schedule breaches, cost breaches (including RDT&E, procurement, PAUC and APUC) and total breaches. The results are shown in Table 2.



**Table 2. Mann-Whitney Test**

Variable	Single System vs. System-of-Systems		Single Service vs. Joint Service	
	Development	Production	Development	Production
	n=48	n=36	n=48	n=36
Schedule breaches	0.0104	0.1558	0.0624	0.2126
Cost breaches	0.0414	0.0225	0.2603	0.5703
Total	0.0276	0.0289	0.1632	0.4497

These findings should be interpreted with a note of caution. For example, the limited sample, the method for categorizing the degree of interdependence or “jointness” and SoS, and the failure to include and control for other important factors may be significant. Though preliminary, these results offer evidence to support further investigations on the role of jointness and SoS in program acquisition.



THIS PAGE INTENTIONALLY LEFT BLANK





## Panel 18 - International Perspectives on Acquisition

---

<p><b>Thursday, May 15, 2008</b></p> <p><b>3:30 p.m. – 5:00 p.m.</b></p>	<p style="text-align: center;"><b>Panel 18 - International Perspectives on Acquisition</b></p> <p><b>Chair:</b></p> <p style="text-align: center;"><b>John F. Schank</b>, Senior Operations Research Analyst, RAND Corporation</p> <p><b>Papers:</b></p> <p><b><i>Summary of Echo's Across the Pond: Understanding EU-US Defense Industrial Relationships</i></b></p> <p style="text-align: center;"><b>Dr. Raymond (Chip) Franck</b>, Senior Lecturer, <b>Dr. Ira Lewis</b>, Associate Professor, Naval Postgraduate School and <b>Dr. Bernard Udis</b>, Professor Emeritus, University of Colorado (Boulder)</p> <p><b><i>Australian Naval Procurement Cycles: Lessons for Other Small Countries</i></b></p> <p style="text-align: center;"><b>Dr. Stefan Markowski</b>, Associate Professor, School of Business, University of New South Wales, Australian Defence Force Academy</p> <p><b><i>Defense Acquisition Policy and Defense Industrial Base Reinforcement Strategy—Enhancing the International Competitiveness of the Korean National Defense Industry</i></b></p> <p style="text-align: center;"><b>Dr. Dae Ok Lee</b>, Principal Researcher, Head of Administration Management Division, Agency for Defense Development in Korea</p>
--	--

---

**Chair: John F. Schank** is a senior operations research analyst at RAND. He has been involved in a wide range of research issues, including shipbuilding acquisition and industrial base analyses, cost analyses, manpower, personnel, and training issues, and logistics. He holds a BS in Electrical Engineering from Drexel University and an MS in Operations Research from the University of Pennsylvania.

---



## Summary of Echoes Across the Pond: Understanding EU-US Defense Industrial Relationships

---

**Presenter: Raymond (Chip) Franck**, PhD, Senior Lecturer, Graduate School of Business & Public Policy, Naval Postgraduate School, retired from the Air Force in 2000 in the grade of Brigadier General after 33 years commissioned service. He served in a number of operational tours as a bomber pilot; staff positions—which included the Office of Secretary of Defense and Headquarters, Strategic Air Command; and was Professor and Head, Department of Economics and Geography at the US Air Force Academy. His institutional responsibilities at NPS have included the interim chairmanship of the newly formed Systems Engineering Department from July 2002 to September 2004, teaching a variety of economics courses and serving on a number of committees to revise curricula for both the Management and Systems Engineering disciplines. His research agenda focuses on defense acquisition practices and military innovation.

Raymond (Chip) Franck  
Senior Lecturer  
Graduate School of Business & Public Policy  
Naval Postgraduate School  
Monterey, CA 93943  
Phone: (831) 656-3614  
E-mail: [refranck@nps.edu](mailto:refranck@nps.edu)

**Author: Ira Lewis**, PhD, is Associate Professor of Logistics, Graduate School of Business and Public Policy, Naval Postgraduate School, Monterey, CA. His interests include transportation, public policy, and the impact of information technology on logistics.

Ira A. Lewis  
Associate Professor  
Graduate School of Business & Public Policy  
Naval Postgraduate School  
Monterey, CA 93943  
Phone: (831) 656-2464  
E-mail: [ialewis@nps.edu](mailto:ialewis@nps.edu)

**Author: Bernard Udis**, PhD, is Professor Emeritus of Economics at the University of Colorado at Boulder and Visiting Research Professor at the US Naval Postgraduate School at Monterey. He has also served as Distinguished Visiting Professor of Economics at the US Air Force Academy, and as William C. Foster Fellow at the US Arms Control & Disarmament Agency. His NATO Research Fellowship examined the costs and benefits of offsets in defense trade.

Professor Udis' published work includes three books: *The Economic Consequences of Reduced Military Spending* (editor, 1973), *From Guns to Butter: Technology Organizations and Reduced Military Spending in Western Europe* (1978), and *The Challenge To European Industrial Policy: Impacts of Redirected Military Spending* (1987). In addition, he has published numerous articles in scholarly journals on defense industries and military power. These include "Offsets as Industrial Policy: Lessons from Aerospace" (with Keith Maskus, 1992), and "New Challenges to Arms Export Control: Whither Wassenaar?" (with Ron Smith, 2001). A number of his works are considered classics in defense economics and have been reprinted in collections such as *The Economics of Defence* (Todd Sandler &



Keith Hartley, 2001) and ARMS TRADE, SECURITY AND CONFLICT (Paul Levine & Ron Smith, 2003).

Professor Udis' current research focuses upon competition and cooperation in the aerospace industries of the US and the EU.

Bernard Udis  
Professor Emeritus  
Graduate School of Business and Public Policy  
13 Camino Real  
Sandia Park, NM 87047  
(505)286-2789  
E-mail: [Bernard.Udis@colorado.edu](mailto:Bernard.Udis@colorado.edu)

---

## Abstract

This report represents the authors' efforts to provide a useful, albeit partial, understanding of the international defense marketplace—which we view as growing increasingly complex. In pursuit of that objective, we provide a brief overview of international defense markets in the context of both changes in military affairs and the various defense industrial bases.

In analyzing the defense market, we essay multiple analytical frameworks (along the lines of *Essence of Decision*). Our analytical models are: (a) a sophisticated view of offsets in a public policy context with market imperfections, (b) transaction cost economics, with our unit of analysis being the nation-state instead of the firm, and (c) two standard corporate strategy models.

To test the models' explanatory powers, we consider three ongoing “cases”: F-35 Joint Strike Fighter, the UK Defense Industrial Strategy, and the Northrop-Grumman-EADS KC-30 proposal. Interestingly, we find all three hypotheses have some explanatory power, but none of the three is demonstrably better than the others (in this small sample).

## Summary

This is a summary of the report cited above for inclusion in the *Proceedings of the Fifth Naval Postgraduate School's Annual Acquisition Symposium* (2008, May). (The report itself greatly exceeds the length guidelines for the *Proceedings*. The topics raised here are discussed in greater detail within the body of that report.)

The motivation for this particular project was our conviction that standard explanatory paradigms for understanding global defense trade, e.g., offsets and related subjects, have been strained—perhaps to the breaking point. Accordingly, we hypothesized that analysis of this increasingly complex market system would be improved by the application of multiple models (as was done by Graham Allison in *Essence of Decision*).

Section I is a brief introduction.

Section II is an interpretative discussion of ongoing developments in the international defense market place. In this section, we discuss the following.



- A. **Military Affairs.** There are two ongoing Revolutions in Military Affairs—one lead by the US DoD, the other by contemporary terrorist and insurgency movements. Accordingly, the international defense market has been significantly affected by the ongoing competition between between two groups that are deliberately engaged in processes of rapid military innovation (both underpinned by contemporary information technology).
- B. **Developments in the Global Defense Marketplace (in general)**—including acquisition reform and the globalization of defense industrial production. We noted in particular the systemic tension between globalization and national sovereignty—an issue that’s especially acute for defense-related goods.
- C. **US and EU Defense Industrial Developments (in particular).** These include the role of US and European defense firms in the world market, recent trends in defense budgets, and patterns of reorganization (generally consolidation). We noted the dangers of relying solely on detailed quantitative analysis to analyze a complex and changing system in the absence of well-defined analytic paradigms.

Section III presents multiple analytical frameworks as a basis for the analysis of complex systems. We then present our three paradigms.

- A. We first summarize Allison’s use of multiple analytical frameworks.
- B. *Offsets* and International Industrial Participation. We hypothesize that although the offsets perspective was not able to offer comprehensive understanding of the international defense market, we believe it still has explanatory power (and are, in any case, obliged to assess its usefulness).
- C. *Transaction Cost Economics* (TCE): TCE was originally developed to study vertical boundaries of firms (the make-or-buy decision in particular). We summarize the relevant considerations for that decision. We expand the standard TCE model somewhat and consider the nation-state as a military enterprise. (One would then view a decision to buy military equipment as a decision to import—as opposed to a decision to rely on domestic sources.)
- D. *Corporate Strategy*: Finally, we introduce two standard models of corporate strategy: Five Forces (Porter, 1980) and “Co-opetition” (Brandenburger & Nalebuff, 1996).

*Section IV* provides narratives of three ongoing “cases”: the Joint Strike Fighter (JSF), the UK Defense Industrial Strategy, and the KC-30 Proposal. For all three cases, we provide an interpretive narrative (up to report publication) and then provide explanations based on the three frameworks (from Section III).

### ***Joint Strike Fighter***

**Offsets:** The JSF seems structured to operate in an offsets-free model. Among other things, the JSF consortium is intended to change foreign military sales customers to stakeholders (who share both in risks and rewards). This arrangement, in turn, is intended to drive the consortium’s focus toward productive efficiency rather than the side payments negotiated in offset agreements. The viewpoints of the JSF



stakeholders (expressed in anonymous interviews) is not fully consistent with that objective.

**Transaction Cost Economics:** From the prime contracting firm's perspective, international trade in defense goods frequently involves the formation of long-term relations—the consequences of which are one of the main concerns of the TCE literature. The JSF strategy is, in a very real sense, intended to delay the “fundamental transformation” from competitive market to something similar to bilateral monopoly.

**Corporate Strategy:** The JSF model addresses every defense industrial firm's concern with buyer power—sovereign entities in this case. The aim is to mitigate this threat to profits by recruiting stakeholders who are well placed to influence the sovereign buyers' behavior—in this case, domestic defense firms in a number of countries.

### ***UK Defense Industrial Strategy (DIS)***

**Offsets:** Taken at face value, the DIS is intended for a post-offsets trading regime. However, a more in-depth reading reveals a careful preparation for negotiations over industrial participation (as tacit offsets). For example, the DIS identifies core industries in which there must be domestic defense participation.

**Transaction Cost Economics:** One of the major purposes of the DIS is protection from the costs and risks associated with outsourcing (importing) major portions of the UK's defense equipment. From this perspective, there are many serious areas of concern associated with importing modern defense systems. The DIS' insistence upon “appropriate sovereignty” in the lifecycle management (and operational use) of this imported equipment is a serious effort to manage and mitigate those risks.

**Corporate Strategy:** The contemporary defense marketplace poses significant threats to the profits (and, therefore, viability) of the British defense industrial base. The DIS first reserves certain categories of defense products to domestic firms. It also insists upon the ability to upgrade, modify and generally manage defense systems throughout their operational life. This is well understood as a strategy for mitigating (foreign) supplier power.

### ***KC-30 Proposal***

**Stealthy Offsets:** The details of the KC-30 proposal, which included provisions for extensive US industrial participation, were really intended to insert offsets into a proposal to a customer who ostensibly did not engage in offset agreements. The evolution of the KC-30's industrial participation component is best understood as a tacit negotiation over offsets.

**Corporate Strategy:** Standard models of corporate strategy clearly reveal the rationale for EADS' entry to the US defense market—with a view to changing its environment by redefining its market niche. The USAF's KC-X project provided EADS with a high degree of market power relative to both its rival and its prospective buyer. The buyer (the US government) insisted upon competition, with EADS being the only reasonable competitor other than Boeing. Hence, the success of the KC-30



in the initial Air Force source-selection process is the result of a very well-crafted corporate strategy (regardless of final outcome).

Transaction Cost Economics: The risks the US would assume in choosing the KC-30 include an international politics of a “holdup”—denying support to KC-30s in US military operations because of source-country disapproval. Hence, the partnership with Northrop-Grumman and extensive KC-30 production work located in the US are readily understandable as means to assure the US government that such risks are not serious.

## Some Conclusions

Basically, we found support for our hypothesis about the international defense market being an increasingly complex system, the study of which usefully involves the application of multiple analytical frameworks.

We conclude, first, that all three of our perspectives have explanatory power in all three cases considered. Second, and also interesting, is that relative explanatory power varied over this small sample. We concluded that the offsets paradigm was best for understanding the Joint Strike Fighter project; that TCE did best for the UK’s DIS; and corporate strategy models provided especially good insights into the KC-30 proposal.

## References (cited in this summary)

- Allison, G.T. (1971). *Essence of decision*. New York: Little, Brown.
- Allison, G.T., & Zelokow, P. (1999). *Essence of decision* (2nd ed.). New York: Longman.
- Brandenburger, A.M., & Nalebuff, B.J. (1996). *Co-opetition*. New York: Doubleday.
- Porter, M.E. (1980). *Competitive strategy: Techniques for analyzing industries*. New York: Free Press.



# Australian Naval Procurement Cycles: Lessons for Other Small Countries

---

**Presenter: Stefan Markowski**

School of Business, The University of New South Wales at the Australian Defence Force Academy, Canberra, Australia

E-mail: [s.markowski@adfa.edu.au](mailto:s.markowski@adfa.edu.au)

**Authors: Peter Hall and Robert Wylie**

School of Business, The University of New South Wales at the Australian Defence Force Academy, Canberra, Australia

---

## Abstract

Defence procurement agencies in smaller countries, such as Australia, face a difficult challenge when seeking to acquire new weapons systems that are either intrinsically complex or idiosyncratically tailored to local needs. If they seek to rely on production in-country, they must draw on domestic infrastructure almost certainly too limited in its technological breadth and depth for the task of efficiently producing a wide range of sophisticated military products, which are likely to be internationally uncompetitive, into the bargain. If they “leave it to the market” and award contracts on the basis of a competitive process and set up arms-length relationships to pursue compliance, they may find themselves hostage to suppliers that cannot be replaced once the contract is under way. If, instead, they seek supplies from government-owned arsenals and shipyards, they may find it difficult to resist political pressures to preserve legacy sectors, facilities and products. And, if they look to overseas suppliers to meet their requirements, they usually lack the market power to negotiate favourable terms and sometimes to have their requirements met at all.

These challenges, and the related issue of whether to use defence acquisitions to support domestic industry, are discussed in the context of procurement of naval vessels and support services in Australia. The country has long had domestic warship building and maintenance capabilities, and its shipbuilding sector “is the jewel in the defence industry crown. Naval vessels are the only major platforms built in Australia, and firms that build them are the highest profile and most prestigious element of defence industry” (ASPI, 2002, p. 8). In this paper, we consider Australia’s three post-WWII shipbuilding cycles to illustrate how successive federal governments have grappled with these perennial procurement challenges. We draw lessons from the first two cycles to explain why and how the government has been driven to increase its responsibility for managing key shipbuilding projects following a period of seeking to rely more heavily on the forces of competitive industrial supply and after nearly a decade of “smart procurement” rhetoric.

Many lessons apparent in the context of Australian naval shipbuilding and repair are relevant to other defence industry sectors. They illustrate a range of problems typical of many Defence-Industry relationships in small countries: local production vs. imports, political and economic vs. strategic aspects of in-country sourcing of materiel, the role of competition, the management of procurement risks, and business models used to engage suppliers and mitigate the risks of inadequate supplier performance.





## Introduction

Naval shipbuilding has consistently captured the attention of the Australian public more than any other area of defence procurement—from the troubled government shipyards of the 1950s and 1960s through to the Collins submarine project of the 1990s (ASPI, 2002). This is partly because naval vessels are the only major platforms built in Australia. And, partly, because the procurement of naval assets and the disposition of industry facilities have long been highly politicised, with the federal government balancing the competing interests of different states, services and industries. As a result, the Australian naval shipbuilding and repair sector has consistently presented governments of the day “with a series of interwoven (procurement) challenges” (p. 1). The response to such challenges has been embedded for 20 years or more in economic and institutional reforms applying to Australian defence industry overall, and the sector has benefited particularly from reforms to the defence supply chain. However, while considerable improvements have been achieved, accounts of project delays and cost overruns still attract media attention and embarrass successive governments.

By the standards of older maritime nations, the industry may not have a long history but it has had its share of both failure and success. Within the former, arguably the most publicised has been the procurement of the Collins Class submarines in the 1980s and 1990s. No other Australian defence acquisition in recent years has had a more profound impact on how the government goes about the acquisition of major strategic capabilities and on the mechanics of the defence acquisition process. As the latest cycle of naval acquisitions has started to unfold, the key question is what lessons have been learned and with what implications for new process.

This would become clear as the Australian government seeks to handle two forms of competition. On the one hand, prime contractors, main systems integrators and some original equipment manufacturers (OEMs) compete *for* a market—the market in new capability elements—by offering alternative specifications of weapons systems sought by Defence (i.e., different platform designs and combat systems). On the other hand, lower-tier contractors compete *in* a market, the market for work subcontracted by primes and higher-tier contractors. In each case, local content requirements and defence procurement policy have a role to play.

This paper is structured as follows. First, we briefly review the history of naval shipbuilding and repair in Australia. We discuss the three post-World War II ship acquisition cycles, which are critical to the understanding of how successive Australian governments have approached naval acquisitions and defence procurement in general. Second, we consider the in-country maritime industry (i.e., shipbuilders and maintainers, facilities and industry disposition, the changing division of labour and the associated supply chains). Finally, we draw some lessons from the Australian naval shipbuilding experience.

## Naval Shipbuilding in Australia

### Post-war shipbuilding cycles

During World War II, Australia became a significant builder and repairer of naval vessels. In total, 113 naval ships were built for the Royal Australian Navy (RAN) at ten Australian dockyards. Also, 4,000 ship repairs were completed for the RAN, 500 for the US Navy (USN) and nearly 400 for the Royal Navy (Parliament of Australia, 2006, p. 41). The



scale of activity declined significantly during the post-war period. Since 1945, Australia has experienced two major naval building cycles separated by a 15-year period of low activity and a third was under way by 2008 (ASPI, 2002).

In the 1950s and 1960s, the first cycle saw nine destroyers built at the government-owned dockyards. The cycle also included an afloat support ship, hydro vessels and patrol boats. In the 1970s and early 1980s, no surface combatants were built in Australia; although, four large naval support and hydrographic vessels were completed, as well as eight heavy landing craft (LCH) craft and 14 patrol boats.

The second naval combatant building cycle began in 1984 with an order for two guided missile frigates (FFGs). This was followed by orders for six Collins Class submarines, ten ANZAC Class frigates (involving workshare arrangements with New Zealand), six minehunters and other ships (e.g., patrol boats and two hydrographic ships). The second cycle will end with the commissioning into service of the last Armidale Class patrol boats in the early 2000s.

The third cycle (much smaller by volume) began in the late 2000s, with tenders for the construction of three air warfare destroyers (AWD), two large landing helicopter dock (LHD) ships, afloat support ships and the watercraft element of the amphibious deployment and sustainment (ADAS) project. This cycle of naval shipbuilding is expected to end around 2016-17, with the next cycle expected to start around 2018.

### **The first cycle: The troubled years**

The construction of destroyers in the 1950s and 1960s was notorious for its cost overruns, schedule slippages and industrial disputes. As noted by the Australian Senate inquiry into naval shipbuilding, “Australia’s increasing resort over the 1960s and 1970s to purchasing foreign naval vessels for the RAN reflected the poor performance of domestic naval shipbuilding projects” (Parliament of Australia, 2006. p. 41). Apart from two oceanographic ships, the government-owned dockyard at Williamstown in Melbourne did not commission a naval vessel between 1971 and 1991 (p. 42). And, after launching HMAS Torrens in 1968, the other major government-owned dockyard at Cockatoo Island in Sydney did not commission another naval vessel until 1986. Thus, no warships were launched in Australia for over 20 years. This preference for imports left Australian naval shipyards with mostly repair and (limited) refit work (p. 42).

An example of local construction problems in the 1970s was the ill-fated DDL (light) destroyer project approved in 1972. Starting in 1975, three locally designed ships were to be built at the Williamstown dockyard. While it was accepted that cost premia for local build were to be incurred, they were justified on the grounds that local shipyards would later be best positioned to provide logistic through-life support and battle damage repairs. Also, investments needed to pump-prime local shipbuilding capabilities were aimed at enhancing the in-country skill base and technological know-how. The project was cancelled in 1973 as the Navy and the Department of Defence found the initial cost estimates to be grossly over-optimistic and a Joint Parliamentary Committee took the position that risks inherent in a local design were excessive (p. 43). A lesson drawn from this experience was “the need for tighter controls on Navy’s design requirements. Part of the problem was that those involved with the specifications for the project were without responsibility for cost and schedule” (p. 43).

Following the cancellation of the DDL project, the government turned to overseas shipyards to initiate the acquisition of guided missile frigates. In 1974, the purchase of two imported FFGs was approved by the government. The vessels were to be built in the USA and acquired under Foreign Military Sales (FMS) arrangements managed by USN. The purchase of a third FFG was approved in 1977 and a fourth in 1980. The ships were delivered between 1980 and 1984, mostly on schedule, but the cost of acquisition ballooned (Parliament of Australia, 2006, pp. 43-44). In part, the cost overrun was due to higher-than-anticipated inflation and exchange rate re-alignment. But the purchase also revealed systemic problems in Australian defence procurement. As new technologies emerged, the first three frigates had to be retrofitted with long-range sonar systems and more capable helicopters. The design of the fourth FFG was altered to incorporate several modifications requested by the RAN. It was argued that some cost overruns might have been avoided “had the RAN seized opportunities to incorporate modifications during the construction phase” (p. 44). The procurement process was thus, apparently, neither sufficiently flexible nor agile to cope with changes in the technical specification of the deliverables.

There were also problems with the use of FMS arrangements. A 1974 Memorandum of Agreement with the US allowed Australia to withdraw from the project if the ships failed to meet the RAN’s requirements or turned out to be “unacceptably costly.” However, the USN and the US Department of Defense resisted changes requested by Australia (p. 44). The Agreement also included a limited “offset-type” provision to make Australian industry manufacture and supply components for the RAN and the USN FFGs. The actual FMS arrangement, as opposed to what was initially envisaged, frustrated all such local content initiatives and restricted the scope for Australian industry participation. A lesson drawn from this experience was that “in future, it was necessary to sign deeds of agreement with the prime contractors before negotiating a Letter of Offer and Acceptance with the US government” (p. 44). Another lesson drawn was that Australian industry was not competitive enough to win work on its own merit and that earlier participation of potential suppliers was needed at the project planning stages if any in-project import substitution was to be achieved (p. 45).

By the end of the 1970s, it was apparent that the naval shipbuilding sector in Australia was suffering from deeply ingrained systemic problems. Industrial relations were particularly bad as naval shipyards were seen by both the unions and the shipyard management as Defence-funded sheltered workshops (Parliament of Australia, 2006). The Department of Defence lacked the ability to specify its needs precisely enough to prevent endemic requirements creep. It also lacked effective contracting skills. This was an important limitation as changing technologies, especially the growing use of electronics and information technology, made naval vessels increasingly complex and knowledge-intensive. Project management skills were also lacking in defence and there were shortages of critical shipbuilding skills at naval yards.

## **Fresh start**

The *1976 Defence White Paper* foreshadowed aspirations to develop local defence industry capabilities to enhance Australia’s defence self-reliance. In line with this aim, the Australian Frigate Project (AFP) was initiated in 1978. The FFG-7 Class frigate would be constructed locally to an imported design that was seen as flexible enough to accommodate high local content requirements. In 1980, the government decided to build two FFG-7 frigates at the Williamstown dockyard, providing that the shipyard “demonstrated its capacity to build the ships to the RAN’s requirements” (pp. 46-47).



The arrival of a new Labor government in 1983 brought with it the re-affirmation of the self-reliance objectives, accompanied by a commitment to microeconomic reform aimed at increasing the competitiveness of Australian manufacturing industry. The government was keen to build warships in-country providing that significant improvements in shipyard productivity could be negotiated and delivered. Preferably, this was to be achieved through transferring ownership to the private sector. Privatisation of government factories and shipyards, including naval shipbuilding facilities, was seen by the government as an essential part of its broader package of “microeconomic” reform. The new government was also ready to confront unions by resisting their demands to build a tanker at Cockatoo Island “ultimately condemning the yard to extinction” (p. 47).

The two FFGs were to be built at the Williamstown dockyard providing that its productivity could be lifted, cost and schedule discipline imposed, and a series of enforceable agreements concluded to tighten work practices and restrict the drift of product specifications. A contract between the Department of Defence (customer) and the Department of Defence Support (contractor) was signed in 1983 for the two ships to be delivered between 1992 and 1994. The contract was to facilitate extensive local industry involvement to enhance national defence self-reliance and navy preparedness. As revealed by the 1986 review of the project by the Joint Committee of Public Accounts, the project budget included a cost premium for the local build of about 30% (p. 48). In 1987, the government sold the Williamstown naval dockyard, with the FFG arrangement, to the Australian Marine Engineering Corporation (AMEC). The privatisation of the yard turned out to be a very successful initiative. Both ships were launched by AMEC ahead of their initially agreed schedule and within the original cost estimates (in real terms). The only real cost increase was attributed to the privatisation process *per se*. Further, local industry content accounted for 90% of the AMEC-borne cost and 75% of the total project cost (Parliament of Australia, 2006).

### **The second cycle: Back on track**

While the beginning of the second shipbuilding cycle may be associated with the FFG project, it really unfolded in the late-1980s. The *1987 Defence White Paper* reaffirmed the Labor government's commitment to the development of competitive local defence industry capabilities, particularly in the shipbuilding sector, and to the policy of defence self-reliance. The second cycle got under way following the government's decision to build six Collins Class submarines, awarding the contract to the Australian Submarine Corporation in 1987; and ten ANZAC (Meko 200 Class) frigates, the contract going to the AMEC-Blohm+Voss consortium in 1989. In 1994, another major contract was awarded to the then Australian Defence Industries (ADI)—now Thales—this time to build, to an Italian design, six Huon Class coastal minehunters. The final contract in the second cycle was signed in 2003 with Defence Maritime Services Pty (DMS), a joint venture between P&O Maritime Services and Serco Australia for the delivery of 14 Armidale Class patrol boats. The fleet was built by Austal Ships Ltd., Australia's largest commercial shipbuilder, and is to be fully supported by DMS throughout its service life (Kerr, 2008a). The second cycle also included some minor naval construction (e.g., Freedom Class patrol boats and hydrographic ships). In contrast to previous periods, nearly all ships required by the RAN during the second cycle were built in-country. The main projects of the second cycle are discussed below.

## ***Collins Class submarine project***

To facilitate building submarines in Australia, the Australian Submarine Corporation (ASC) was established in 1985 as a joint venture between Sweden's Kockums (as shipbuilder and designer holding 49% of the company's shares), the Australian government-owned Australian Industry Development Corporation (49%) and Wormalds International and Chicago Bridge and Iron (holding the 2% balance of shares). In 1987, ASC was chosen as the prime contractor for the fixed cost Aus\$3.9 billion (1986 prices) project to deliver six submarines. With over 73% local content for the six platforms, at least 3,500 suppliers, and 1,600 individual contracts (Parliament of Australia, 2006, p. 56), the project was "Australia's most ambitious and technically advanced defence project ever" (McIntosh & Prescott, 1999, p. 5).

The submarines experienced much publicised teething problems but were eventually acclaimed as "world class" (Parliament of Australia, op. cit.). The main early problem was attributed to a decision to acquire a sophisticated combat data system (CDS) independently of the platform design when the most straightforward approach would have been to select a design with the CDS fitted as standard (Woolner, 2006, p. 72). This was compounded by Navy's preference for the CDS to be developed in order to meet its unique requirements rather than purchased as a military-off-the-shelf (MOTS) system (Woolner, 2001, p. 9). "By including the combat system with the platform in the single prime contract, with a unique military specification, Defence left itself wide open to [...] technological problems" (McIntosh & Prescott, 1999). By 1993, it had become apparent that Rockwell, the CDS sub-contractor and designer, was not able to meet Navy's specifications. Nevertheless, Defence did not authorise a replacement MOTS system. The first submarine was provisionally accepted into service in 1996 with the combat system incomplete and, by the late 1990s, the Collins Class project had become a major embarrassment for Defence and the government.

In 1999, the government terminated the failed CDS sub-contract and sought another CDS contractor through open competition. In 2001, however, the government decided to scrap the tender process and awarded the contract to the US firm Raytheon. Later that year, the RAN and the USN signed an agreement to cooperate in equipment-sourcing and logistic support and to enhance Collins Class interoperability with US ships. The German STN Atlas was also awarded a contract for sonar and navigation equipment (Parliament of Australia, 2006, pp. 59-60).

The sequence in which the six hulls were constructed allowed for little learning by doing. As a former high-ranking naval officer argued during a 2006 parliamentary inquiry, "there is a need to have an increased gap between the lead ship of a class and its successor. The lead ship needs to be evaluated and give the all clear before the successor is completed" (Parliament of Australia, 2006, footnote 31, p 59). Instead, the ships were largely batch-manufactured and batch-constructed. While economies of scale and scope are unavoidably lost through fragmenting the sequence of ship construction, there is more opportunity to alter the specifications of successor ships by learning from the in-service performance of their predecessors. This principle of "spiral" or incremental new capability



formation was well understood and practiced in Sweden where the Collins Class design originated.<sup>58</sup>

Criticism has also been directed towards how the project was commissioned and managed by Defence. A fixed-price contract was used to avoid cost overruns associated with traditional cost-plus contracts, and to shift most product- and (construction) process-related risks from the Commonwealth to the contractor. However, the use of a fixed-price contract for that reason was flawed on three accounts:

- for a country lacking experience as the builder of modern, sophisticated weapons systems, the magnitude of the technological challenge inherent in this project was grossly underestimated by both by the ASC as a contractor and by Defence as a customer. There was too much reliance on Kockums' expertise as a builder of submarine platforms and a rather poor understanding of technological challenges posed by the development of the bespoke CDS. In such circumstances, the Commonwealth (Defence) might have realised the limitations of risk-shifting between the parties and, instead, relied on risk-sharing mechanisms such as those provided by incentive contracts and risk mitigation through more collaborative management of the project;
- given the developmental nature of the project, the use of a fixed price contract provides little effective protection for the buyer (Defence) since contract variations are inevitable. An *ex-ante* fixed-price contract may in reality, become an *ex-post*, cost-plus arrangement. If contract variations are regularly approved, there is no incentive for the contractor to seek cost efficiencies. It would have been preferable to use a flexible form of contract to allow for learning, to provide incentives to improve and share risks rather than to end up with the *de facto* cost-plus arrangement dressed up as a fixed-price contract; and
- a belief that project risk could be shifted to the contractor to reduce the Commonwealth's exposure was naïve, given the ASC equity structure. With its 49% share of equity, the Commonwealth was both the sole buyer of the ships and a key shareholder on the supply side. In 2000, when Kockums was acquired by the German submarine builder HDW, the Australian government stepped in to buy the Kockums' share of ASC equity.

This contractual debacle was summarised by an Australian parliamentary researcher thus:

The most compelling lesson that can be learnt from the Collins submarine program is the importance of selecting the procurement strategy to suit the nature of the project. In hindsight, the point where it was decided to develop a unique design for the new submarines was the time to change the procurement strategy. (Woolner, 2001, p. 47)

The nationalisation of ASC was an embarrassment for a government overtly committed to the privatisation process: "There was more than a touch of irony in the fact that

---

<sup>58</sup> Sweden has traditionally ordered its submarines in very small batches to allow for benefits of learning-by-doing and technological change to be continuously absorbed into subsequent designs—even though it has been well understood that cost premia would be incurred as a result of fragmented production.

after decades of effort to transfer all defence production capability to commercial industry, the Government finds itself the owner of ASC" (ASPI, 2002, p. 24). But, the nationalisation of ASC also exposed a more serious flaw in the procurement philosophy that was inherent in the Collins Class acquisition. Under the original contract, Kockums retained much IP in the vessel's design. The ASC shareholding arrangement made it difficult to determine the ownership of various IP changes to the original design, new IP elements and the associated body of design data that were critical to access if ASC was to carry on as the ship's maintainer and modifier. The resultant legal dispute took until 2004 to resolve. Under the new arrangement, Kockums owns the legacy IP but ASC has full access to it (Parliament of Australia, 2006, p. 55).

The introduction of sensitive US technology into the vessels and the involvement of the US firm Electric Boat as a capability partner with ASC added another degree of complexity to the IP dispute. The inadequacies of the Collins Class technology management highlight the critical importance of access to proprietary technological know-how and IP in all knowledge-intensive projects. This is often poorly understood in large, technologically complex, developmental projects in which a detailed design does not exist at the time a contract to proceed with the project is signed. Thus, a classic "hold-up" relationship may emerge between the parties as the buyer belatedly realises that its ownership of an asset is incomplete without the transfer of all IP. The incompleteness of ownership rights imposes severe limitations on who is allowed to maintain the asset and who has the right to modify it. By the time the buyer becomes aware of such problems, the cost of contract re-negotiation may be prohibitive and opportunities for switching suppliers limited. This problem is compounded when the product design incorporates "black boxes," which can only be accessed by the original supplier or its agent and which are subject to technology restrictions imposed by the supplier's home government.

In sum, the Collins Class project "exposed serious flaws in defence's procurement processes" (Parliament of Australia, 2006, p. 57). Its well-publicised difficulties were not only embarrassing for the government but also made the government determined to change the nature of its principal-agent relationship with Defence. Following yet another review of new capability formation and procurement management by Defence (*Kinnaird Report*), the government decided to restructure the Defence Materiel Organisation (DMO—its procurement agency) into a "prescribed agency" (partially detached from Defence and reporting directly to the government) to handle defence procurement and through-life capability support. In particular, DMO was to foster the kind of professional project management expertise required to bring rigour and experience into the procurement process and to end the long tradition of well-intended and energetic but sometimes amateurish project management.

### ***ANZAC frigate project***

At Aus\$7 billion (2006 prices), the ANZAC Frigate project, was the largest *single* Defence design and construction contract awarded in Australia in the closing decades of the 20th century. It was also the only European-style naval "workshare" contract. There were two customers, the navies of Australia (eight ships) and New Zealand (two ships) and the industry workload was shared between the two countries. It was expected that neither navy would cross-subsidise the shipbuilding costs of the other; sub-contractors were to be selected competitively; and the achieved workshare between the two countries was to reflect the overall cost shares. The frigates were assembled at the recently privatised AMEC





shipyard at Williamstown with modules built at this and other shipyards in Australia and New Zealand. During the contract life, the shipbuilder changed its name twice to finally become Tenix Marine Division of Tenix Defence Pty Ltd. (Parliament of Australia, 2006). By the early 2000s, Tenix Defence—incorporating the marine division—had become one of Australia’s largest defence contractors.

Despite its initially limited experience as a shipbuilder, Tenix completed the project on schedule and on budget. This outcome was helped by the modular ship construction and by a collaborative and highly synergistic arrangement with SAAB, the combat system supplier, to test the combat system prior to installation (Tasman Asia Pacific, 2000, p 9). A requirement for the project was to achieve high levels of local content (the then government policy of *Australian Industry Involvement, All*). This was in part accomplished through effective sub-contracting with the help of the Industrial Supplies Office (ISO), an agency set up to assist small and medium sized enterprises (SME) in broadening their customer base. The search for subcontractors to meet the All target sometimes involved what a Tenix manager described<sup>59</sup> as “reverse garage sales,” i.e., components were put on display and SMEs were invited to decide which of these products could be made locally. This approach to sub-contracting has been acclaimed as a factor contributing to the project’s cost and schedule discipline and copied by other projects (Tasman Asia Pacific, 2000).

In 2001, Tenix, SAAB and the DMO (Defence) signed a tripartite long-term alliance agreement (the first of its kind) to provide in-service support for the ANZACs and to collaborate in future modifications and capability enhancements of the class (Parliament of Australia, 2006). This agreement concluded Tenix’ involvement in the second shipbuilding cycle and positioned the company favourably as a bidder for construction work in the third cycle (see below).

### ***Minehunter coastal project***

In 1989, Australian Defence Industries (ADI) was formed as a corporatised, government-owned entity set up to consolidate major defence industry facilities still in government ownership. This included naval engineering at the Garden Island dockyard in Sydney. ADI was awarded the prime contract for the Huon Class minehunters, based on an Italian design but with ADI as the designated design authority to modify and Australianise the design. The Aus\$ 917 million (1994 prices) project was the first Australian-sourced naval project in which the local prime contractor was given design authority (p. 67). The six ships were built on schedule at a greenfield site facility employing new, ‘greenfield’ labour force (Parliament of Australia, 2006). The first composite hull was made in Italy and the remaining five in Australia. The key to tight schedule success was an onshore facility that integrated and tested the combat system prior to installation (Tasman Economics, 2002, p. 9). As with ANZAC frigates, the Huon Class also complied with a high local content target of nearly 70%.

In 1999, the French Thales and Australian company Transfield bought ADI from the Federal Government as a 50-50 venture (Parliament of Australia, 2006. p. 71). In 2006, Thales Australia was granted government permission to acquire the Transfield’s share and consolidate it with its other Australian assets. This acquisition has turned Thales into one of

---

<sup>59</sup> During one of the authors’ visit to the Williamstown shipyard in the mid-1990s.

Australia's largest defence contractors and a key naval repair, maintenance and upgrade contractor.

### ***FFG upgrade project***

In contrast with the very successful minehunter project, ADI's Aus\$1 billion upgrade of four FFGs has been plagued with problems. This project, commissioned in 1999, involves the upgrade of ships' combat systems. Initially, it was to cover six ships but as the first ship was delivered three years late (in 2006) and over budget, the project scope was reduced to four vessels. The upgrade is very extensive and has required advanced design and engineering work, including the ADI-designed and developed Australian Distributed Architecture Combat System (Parliament of Australia, 2006, p. 69). However, "the Department of Defence noted that while ADI is viable in the ship repair and upgrade activity, it is having problems in meeting schedule and performance specifications" (p. 69). Comments such as this cast doubt on Thales' chances of success in the next shipbuilding cycle, even though in 2007, it was Australia's largest defence contractor (Hinz, 2007-2008).

### ***Armidale patrol boats and multihulls***

In Australia, there are two relatively small but internationally competitive commercial builders of aluminium multi-hulls: Austal Ships Ltd (Austal) and Incat. While they have no experience building large steel vessels, both companies have established market niches in wave piercing multi-hulls, fast multi-hull ferries and luxury motor yachts. Both companies have also been successful exporters and are well regarded internationally for their innovative designs.

In 2003, Austal won an Aus\$553 million project to build 14 *Armidale* Class patrol boats—the last major contract of the second shipbuilding cycle. This contract was innovative in that Defence's requirements were framed in terms of operational performance specifications (e.g., operational availability) rather than set as detailed technical guidelines for ship designers.

In 2001, Austal also opened a US shipbuilding facility in Mobile, Alabama. From this foothold in the US shipbuilding market Austal operates as part of the General Dynamics team building prototype littoral combat ships (LCS) for the US Navy. Austal's role is to design and build the LCS platform for USN.<sup>60</sup> Austal is the only Australian naval shipbuilder to be involved in foreign direct investment in offshore construction facility while retaining its core design team in Australia.

In the early 2000s, Incat sold and leased out high-speed catamarans to naval users, including the Australian Defence and the US Department of Defense. However, while the adaptability of these civil ship designs to military uses provides an example of dual-technology opportunities inherent in civilian designs, the company has no intention to expand its operations into naval shipbuilding (Parliament of Australia, 2006, p. 74). Other small shipbuilders and repairers include Forgas with its facilities in Newcastle and Brisbane, and NQEA based in Cairns.

---

<sup>60</sup> If the LCS program proceeds, the US LCS trimaran project may involve the building of 60 vessels at a cost of US\$15 billion (Parliament of Australia, 2006, p. 72).



### Third post-war cycle

Based on the 2006 *Defence Capability Plan* (DCP) and anticipated upgrades and maintenance, Defence intends to spend about Aus\$30.5 billion (2006 prices) on naval construction and sustainment programs between 2006 and 2025 (ADO, 2006b, para. 3.4). While the proportion of local content differs from project to project, about Aus\$19 billion (63%) could be spent in Australia.

At the start of the third construction cycle in 2007, much Defence demand for naval construction and through-life support work over the subsequent period was committed under supply arrangements already in place or soon to be finalised. These included:

- the sustainment contracts for ANZAC frigates (Tenix Marine with SAAB as the combat systems integrator), Collins Class submarines (ASC with Raytheon as the combat systems integrator), and Armidale Class patrol boats (Defence Maritime Services);
- a construction contract for three air warfare destroyers (AWD) awarded to ASC, based on the Spanish Navantia design (see below), and a contract with Raytheon for the AWD combat system, which is likely to be followed by a future contract for through-life support with the two companies; and
- a contract for two landing helicopter dock (LHD) ships awarded to Tenix Marine, again based on Navantia design, which is also well positioned to win a future contract for the LHD sustainment support.

The early commitment of such a large proportion of the 2006-2018 spend limits the scope available to Defence to attract new competition into the domestically located market before the onset of the fourth shipbuilding cycle around 2018. Although the support arrangements for the AWDs and LHDs are yet to be decided when their construction phase draws to a close (the first ships are expected to be delivered in 2012-2013), the logic of Defence sustainment requirements favours the existing supplier consortia.

Also, with the resource export boom in the late 2000s and, thus, tight labour markets, Defence has an incentive to build non-combatant vessels overseas. At an international level, competition is already strong and the competitiveness of the market could be reinforced by the availability of second-hand civil ships that could be adapted locally or overseas for Australian use.

Defence continues to source overseas designs for its major platforms (e.g., AWDs and LHDs). However, past schedule slippages and cost overruns have reduced its appetite for extensive Australianisation. As the success of the Spanish Navantia in winning the AWD and LHD contracts has demonstrated, overseas shipbuilders with successful designs adopted by a foreign parent navy will be able to compete for work in Australia by teaming with Australian prime contractors. Over the past 20 years, this preference for imported designs has produced competition between design-based consortia of shipbuilders, integrators and OEMs, fronted by domestic prime contractors but also including overseas designers and suppliers. This form of competition, and the increased market contestability resulting from the threat of foreign entry, has benefited Defence in that it has produced greater market rivalry and increased scope for benchmarking alternative delivery arrangements.

## Naval Maritime Industry

### Shipbuilders and ship repairers

The traditional concept of “naval maritime industry” focuses essentially on shipyard-based shipbuilding and ship repair/maintenance activities. In this narrowly focused approach to defining the industry, ship assembly and module manufacturing are included as long as module building and component manufacture are undertaken by specialised shipbuilders. Second-tier suppliers of major maritime equipment such as power plants or navionics, normally OEMs, and maritime service providers such as naval architects and surveyors are also included. However, jobbing firms supplying components made-to-order are likely to be excluded as are most third-tier subcontractors.

Another distinction has traditionally been drawn between *shipbuilding*, including capability upgrades and *ship sustainment* (maintenance and repair, including battle damage rectification). These two sub-sectors are essentially shipyard-based, using specialised infrastructure such as dry docks and sea lifts. In Australia, these two sectors have tended to operate in parallel, with the yards involved in ship repair and maintenance separated from those used in shipbuilding (e.g., the Garden Island dockyard specialising in ship repair while the Williamstown dockyard is used to integrate new vessels). This division of labour has evolved to allow platforms, once constructed by specialised and often overseas-based shipbuilders, to be maintained and repaired by “jobbing” repair yards with on-board equipment supported by OEMs and jobbing contractors. This division of labour often required long supply chains linking OEMs to maintenance shipyards and led to delays in the availability of parts and long repair turnaround times.

Changes to the traditional division of labour between shipbuilding and ship repair/maintenance were driven by the growing complexity of platforms: ships were becoming increasingly automated, requiring the integration of on-board equipment into larger, network-based and knowledge-intensive systems. Sophisticated ships such as modern submarines and AWDs are increasingly maintained by their builders, companies that retain the IP they have created in platform design and/or work closely with the design authority to protect and support the integrity of ship design. The retention of or access to design IP, the use of dedicated facilities and the tacitness of ship-specific knowledge gained during the construction phase underpin the shipbuilders’ competitive advantage in through-life upgrade and maintenance work. Thus, strong synergies (economies of scope) have come to exist between the construction and sustainment phases of naval capability. Also, when ships are built in small batches with long gaps between shipbuilding cycles, resources used in construction (e.g., specialised labour, docking facilities) may subsequently be redeployed in fleet sustainment.

In Australia, this synergistic relationship between ship construction and sustainment phases was first exploited in the Collins Class submarine project: the Osborne construction facility in South Australia is dedicated to the production and deep maintenance (full docking) cycles of the class. However, routine maintenance work is undertaken in Western Australia, where the ships are home-ported. This model of “construction-enabled” ship maintenance

has now been adopted in the sustainment of other vessels (e.g., the ANZACs) and is also likely to be used in support of future additions to the fleet (e.g., AWDs and LHDs).<sup>61</sup>

Australia's naval shipbuilding activity is largely confined to four main shipbuilders: ASC, Tenix Marine, Thales (ADI) and Austal. Of these, ASC and Austal are currently Australian-owned while Thales is a fully owned subsidiary of the French parent company and, in 2008, BAE Systems was finalising the acquisition of Tenix Marine.<sup>62</sup> As the third post-war building cycle began to unfold, three of these companies were involved in the construction of the AWDs, LHDs, and afloat support ships; the progressive upgrades of ANZAC and FFG frigates, the Collins Class submarines, minehunters and other minor war vessels; and maintenance of the fleet-in-being. Defence Maritime Services (DMS) are responsible for the maintenance of Armidale Class patrol boats built by Austal. (Some module building and consolidation work and maintenance activity has been undertaken by smaller maritime suppliers such as Forgacs, with facilities in Newcastle and Brisbane, and NQEA in Cairns.) The three shipbuilders and DMS are also the main providers of naval sustainment support the submarine deep and intermediate maintenance cycles, ANZAC and FFG frigate sustainment, support for minehunters, patrol boats, and other minor war vessels.

### Facility disposition and ownership

In the 2000s, Defence's preferred industry disposition reflects the RAN's fleet basing strategy, which envisages the maintenance and home-porting of major surface ships on the east coast of Australia (Sydney) at Fleet Base East (FBE) and on the west coast (near Perth) at Fleet Base West (FBW). The submarines are home ported and maintained at FBW but all full-cycle dockings (deep maintenance) are carried out in South Australia. Minor war vessels are mostly home-ported and supported in Darwin and Cairns.

The home-porting of naval vessels at FBW has spawned the development of navy-preparedness-related industries in close proximity to the ships they support. Thus, in addition to major shipbuilders and repairers (e.g., Tenix Marine, ASC, Austal), other designers and builders of aluminium boats and ships and engineering firms supporting resource projects have clustered in Western Australia, in particular at the Australian Marine Complex (AMC) in Henderson. There appear to be strong *agglomeration economies* that naval firms can gain by locating at AMC. There is also more scope for forging direct business links between firms that operate in close proximity.

In the previous naval shipbuilding cycle, ownership of capital-intensive facilities (e.g., shiplifts and dry docks) was a key characteristic of naval shipbuilders. This is still largely the case; however, the high cost of establishing and maintaining such facilities constitutes a formidable barrier to entry into the Australian market for naval shipbuilding and repair. The

---

<sup>61</sup> Under this model of construction-enabled ship maintenance, two major contracts were let. In 2001, Defence signed a long-term alliance agreement, underpinned by a through-life support contract, with Tenix Marine (shipbuilder) and SAAB (system integrator) covering the development of all future capability change packages for the ANZAC ships. In 2003, it signed another long-term contract with ASC for the 25-year, through-life support for the *Collins* Class submarines.

<sup>62</sup> However, in 2007, Tenix Defence, including its Tenix Marine Division, was offered for sale and BAE Systems Australia was rumored to be the most probable buyer. Also, as ASC is likely to be offered for sale in the late 2000s, Australian subsidiaries of major foreign companies may be invited to bid for it.



provision of these facilities involves high-fixed costs, which can only be recouped over the long term and which even the largest marine companies have difficulty absorbing in the relatively small Australian market. An example of such a facility is the shiplift/transfer system operated by Tenix Marine's facility also located at Henderson, WA. This facility was initially funded by Defence and the WA State Government but subsequently sold to Tenix Marine (Tenix, 2001). Apparently dissatisfied with this arrangement, the West Australian (state) government developed, adjacent to the Tenix facility, a protected deepwater harbour—a 15,000 tonne service and heavy lift wharf, and several other facilities, including offices, workshops and other amenities. This investment, completed in mid-2003, is owned by the State Government and operated by AMC Management (WA) Pty Ltd as a common user facility (CUF). While Tenix' Henderson facility is maintained by the company for its own use, the CUF is deliberately designed for multiple users, including the oil and gas, resources, marine and defence industries and is sufficiently large to accommodate several projects simultaneously. Parties using the facility provide their own management and workforce and accept normal project accountabilities. They use the CUF only when their projects require it and are charged only for the specific facilities they use for a particular period. This arrangement greatly reduces project set-up costs and company overheads, thereby enhancing CUF-users' potential ability to win contracts.

Initial infrastructural investments in the Henderson CUF attracted complementary private investment on land adjacent to the marine complex (e.g., ASC is establishing its submarine maintenance facility there). In response to these developments, the West Australian government invested an additional Aus\$81.5 million in a floating dock to launch and dock large ships and a rail transfer system to allow construction and repair within the CUF's undercover facilities; an extension and upgrade of the existing wharves to accommodate all types of naval and commercial vessels; and the installation of marine services such as power, seawater fire main, wharf communications and sewerage off-take.

The South Australian government followed suit with plans to invest Aus\$300 million in Techport Australia, including a CUF adjacent to ASC in Osborne (Kerr, 2008b, p. 2). The SA CUF is scheduled for completion in 2010 and, like its WA counterpart, is intended to support multiple projects concurrently. The nearest equivalents to such infrastructure on the east coast are the Captain Cook Dock (leased by the Commonwealth to Thales at Garden Island, Sydney).

The introduction of CUFs funded by state governments and, subject to leasing arrangements, on-going Commonwealth ownership of the Captain Cook Dock combine to reduce the significance of facilities ownership as a barrier to entry, particularly in the market for naval ship repair. As an indicator of policy trends, they also suggest a reappraisal of the value of public ownership of assets which governments were so determined to privatise in the late 1980s and 1990s.

## **Changing division of labour**

The impact of defence procurement on industry was traditionally viewed in terms of the relationship between an agency responsible for defence procurement and the prime contractors with which it negotiated. These days, however, it is recognised that effective procurement depends on the activities and performance of a much wider range of industry players, domestically and overseas.

Defence considers the naval maritime industry in broad terms that embrace not only shipbuilders and maintainers but also a myriad of second- and third-tier SME suppliers (ADO, 2006a, paras. 1.18-1.20). The latter reportedly account for some 70% of the total cost of a shipbuilding project.<sup>63</sup> As noted in the Defence submission to the 2006 Senate Inquiry, a typical frigate comprises some 170,000 parts and components provided by 600 suppliers and sub-contractors and takes 1.2 million person-hours, spread over 22 months, to construct. A large conventional submarine may consist of some 500,000 parts provided by 1,600 suppliers and takes 2.5 million person-hours and 60 months to construct (ADO, 2006a, Figure 1).

**Table 1** shows the stylized breakdown of typical warship production costs that includes all on-board combat systems but excludes capability elements that are shore, rather than ship-based. In the table, the platform element of capability accounts for 33% of the total production cost for a more technologically complex naval combatant: a 3,500 tonne frigate costs about Aus\$600 million to build, while on-board combat systems account for 42% of the cost. The other two cost items are largely platform-related and represent the cost of logistic support acquired during the construction phase and the cost of project (delivery process) management. By way of comparison, for a large naval support ship constructed closer to commercial standards, on-board combat systems account for only 15% of all costs and the platform for 47% of the total. For a naval combatant capability, therefore, the combat systems component of the overall system is the most important element, both in cost and functional terms. This is reversed in the case of the naval support capability. For a typical combatant ship, imported combat systems and other major equipment account for 50% of the construction cost (para. 2.5). For technologically complex vessels, such as the submarines and the AWDs, the proportion is likely to be much higher.

**Table 1 Percentage Cost Breakdown in Warship Production**  
(Based on ADP, 2006a, Table 1, para. 2.2)

Production cost element	Surface combatant ship	Support ship
	%	%
Platform design, hull, machinery and equipment	3	47
Combat systems	41	15
Logistics support and training (mostly platform-related)	17	25
Project management	9	13
<b>Total</b>	<b>100</b>	<b>100</b>

In Australia, combat systems integrators (e.g., Raytheon, Thales, BAE Systems) and OEMs (e.g., STN Atlas) are either subsidiaries or agents of major overseas companies (with

<sup>63</sup> These suppliers are said to contribute “70% by value of a project” (ADO, 2006a, para. 1.18). However, the third-tier contractors, as well as other tiers of suppliers, should not be seen as a reflection of a hierarchical industry structure. These relationships are project-specific. Thus, a large firm that is engaged as a prime contractor in one project may be a third-tier, sub-contractor in another.



the notable exception of CEA Technologies). In the early 2000s, the Australian industrial footprint of these multinational companies varied from significant (Raytheon, Thales) to small (Lockheed Martin). The footprint could, in most cases, be flexibly expanded or shrunk, depending on the quantity of in-country work in hand. Much has been claimed by these subsidiaries for their direct access to the parent company's global network and technology. However, Defence has at times observed, "experience indicates that they have difficulty obtaining suitable licensing and intellectual property rights which in turn may have time and cost implications particularly in providing sustainment" (ADO, 2006a, para. 2.9). For this reason, the Commonwealth sometimes facilitates technology transfers using government-to-government arrangements (e.g., the US FMS framework) to secure access to sensitive foreign equipment, military technologies and IP (e.g., the direct purchase of the US Aegis combat system for the AWDs by Defence from the US Navy under the FMS arrangement). Such Commonwealth action has direct implications for the role of prime contractors, an issue we address below.

Critical to the provision of through-life support is access to the IP behind the *ship design*. At the smaller-vessel end of the naval market, Austal is, arguably, the only Australian shipbuilder offering world competitive naval design expertise for multi-hull aluminium vessels.<sup>64</sup> For larger and/or more complex ships, Australia has been an importer of ship design, usually from parent navy ship designers such as the German Blohm+Voss for Meko 200 Class frigates (ANZAC ships) and the Swedish Kockums for the Collins Class submarines. However, design adaptation to meet the Australian Navy's unique requirements and political pressures to increase local content have resulted in considerable Australianisation of original designs. In the Collins Class case, this was further complicated by the transfer of ASC ownership to the Commonwealth. It was only when the Commonwealth negotiated full access to the Kockums-owned IP that ASC became the *de facto* design authority for the class of which the RAN is the parent navy. Similarly, Tenix Defence is the *de facto* design authority for ANZAC ships. The Huon Class minehunter was "the first Australian-sourced naval defence project in which the prime contractor (ADI now Thales) *was given* design authority" (para. 4.39, our italics). This is in marked contrast to the ANZAC ship and Collins Class projects, in which Tenix and ASC effectively became design authorities by default.

Defence appears to be determined to avoid excessive Australianisation in ship design in the next generation of vessels to be constructed in Australia: the AWDs, LHDs and afloat support ships. For example, in the case of AWDs, the government overruled Navy's reported preference for the unproven Gibbs & Cox adaptation of the Arleigh Burke destroyer in favour of the already-operational Spanish design based on the Navantia-built F100 destroyer (Walters, 2007, 1 March, p. 8).

## Marine Industry Supply Chains

Defence's broader approach to what constitutes the naval marine industry has also shifted the emphasis from functionally based naval industry sectors, such as shipbuilders, OEMs and ship repairers, to capability-centered supply chains that include combat systems integrators and the plethora of second- and third-tier suppliers, many straddling sectoral

---

<sup>64</sup> This is reflected in its aforementioned involvement as a ship designer and potential builder in the General Dynamics-led bid for the US Navy Littoral Combat Ship.

divisions and serving different customers in different industries. While the functional representation is helpful in identifying firms largely dedicated to shipbuilding and fleet sustainment, the supply chain framework sheds more light on the competitive dynamics of defence capability supply.

Two types of prime contractor arrangements and, thus, supply chain structures, have dominated the interface between Defence and Australian naval shipbuilders:

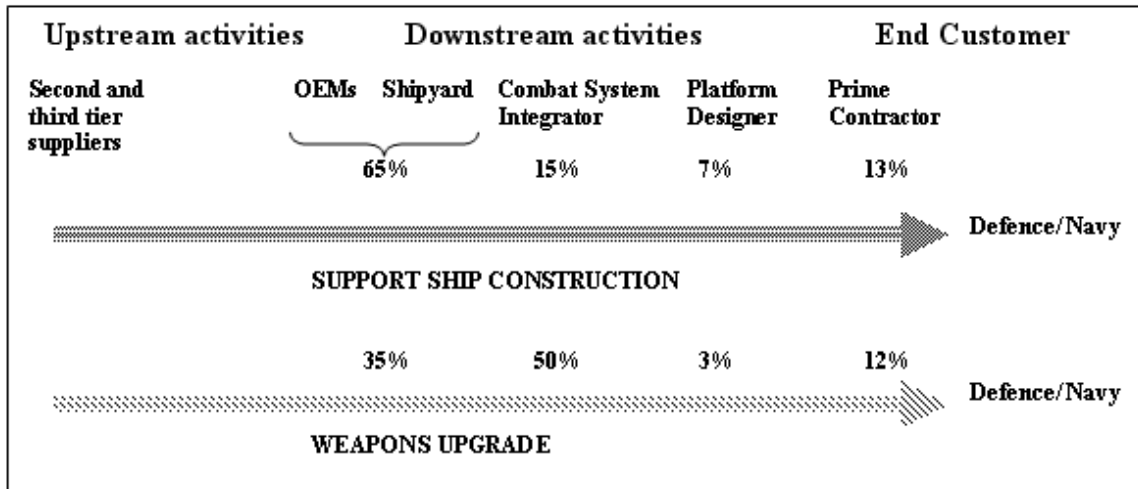
- a *traditional single channel model*, under which a single prime contractor is engaged by Defence to lead and manage the supply chain and to orchestrate all the back-to-back contracts with upstream suppliers of systems, equipment, components and services; and
- a *complex multi-channel model*, in which two or more prime contractors are engaged by Defence to lead and manage parallel supply channels that jointly produce the required capability element.
- These two models are used both in shipbuilding and through-life fleet sustainment.

To illustrate, consider Figure 1, in which two stylized traditional supply chain management (SCM) models are shown: one for the construction of a support ship and another for a major weapons upgrade.<sup>65</sup> In the shipbuilding case, the shipbuilder is also a prime contractor who engages a system integrator and OEMs as well as a large number of small second- and third-tier subcontractors to produce the end product: a platform with all systems and equipment integrated into it or on it. Although the ship design is likely to be imported and Australianised, it is a relatively simple design. Given its role in the process, the prime contractor, as the project's manager, accounts for about 13% of the total project cost. In the weapons upgrade case, much greater weight (and cost share) is assigned to combat system integration but project management by the prime contractor still accounts for about 12% of the total project cost.

---

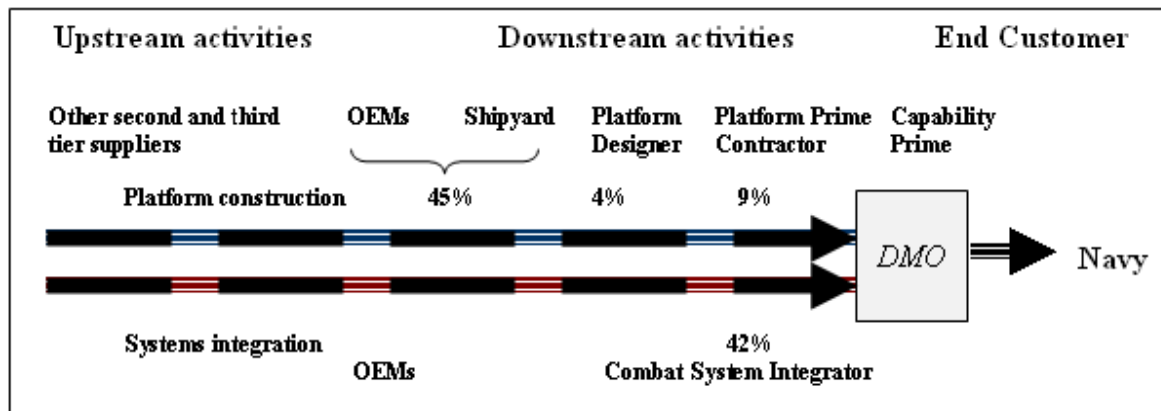
<sup>65</sup> The figure has been stylized using total project cost breakdown by project elements shown in ADO (2006a, Table 1, p. 8). Thus, the cost of "platform design" is imputed to Platform Designer; the cost of "combat systems" is imputed to Combat System Integrator; and the cost of "project management" to Prime Contractor. The cost of "hull, machinery, equipment" and "logistics support, including training" is attributed to Shipyard (operator) and OEMs. Other second- and third-tier suppliers are included in OEM, Shipyard and Combat Integration cost elements.

**Figure 1 Conventional Value Chains for Support Ship and Weapons Upgrade:  
Total Project Cost Breakdown by Supplier Category**  
(Based on ADO, 2006a, Table 1, p. 8)



The conventional prime contracting model has traditionally been used by Defence as a risk management arrangement under which the prime contractor is expected to manage and mitigate risks associated with the operation of the supply chain. This model was used by Defence during the second building cycle in all major shipbuilding projects, initially including the Collins Class submarines. But the conventional model failed the test when the Collins Class project ran into problems with combat system integration. By 1993, Rockwell, the combat systems integrator, was not able to comply with Navy’s specifications and “ASC effectively lost control of the Rockwell sub-contract” (Parliament of Australia, 2006, para. 4.18). As noted earlier, the solution involved replacing the original combat system integrator and Defence awarding the contract to Raytheon in 2001 (Parliament of Australia, 2006). Under this arrangement, Raytheon became a parallel prime contractor for system integration. To complicate the model further, “*Defence itself has essentially primed*” the subsequent Aus\$500 million combat data system replacement program by purchasing the FMS-mediated software and working *with* ASC, Raytheon, Atlas Electronics and Thales Underwater Systems to integrate all combat systems (para. 4.20, our italics).

**Figure 2 Complex Supply Chain for a Naval Combatant: Total Project Cost Breakdown by Supplier Category**  
(Based on ADO, 2006a, Table 1, p. 8)



The resulting structure is represented in Figure 2, which shows a complex, multi-channel supply chain (say, for a frigate-type naval combatant). In the figure, the stylized supply chain involves two *parallel channels* of progressive value-adding activity: platform construction and systems integration. The figure highlights downstream activities (close to the end customer) such as project management, design, and platform integration along the platform construction supply channel and combat system integration along the systems integration channel. Further upstream are OEMs that provide equipment and subsystems for downstream platform and systems integrators and other second- and third-tier subcontractors who provide inputs for OEMs and downstream integration activities. Some of these smaller second- and third-tier contractors are specialised naval suppliers but most tend to be broadly based manufacturers and service providers. Also, some apparently small subcontractors (in terms of quantities and dollar value of supplies) are subsidiaries or agents of large producers of generic products. As we move from right to left along each supply channel, from downstream to upstream activities, suppliers are less likely to be dedicated to the production of naval systems. The reduced role of the prime contractor for the platform is indicated by the smaller proportion of the total project cost (9%).

This representation of the naval construction supply chain for complex projects emphasises the changing concept of the prime contractor. In this case, there are two prime contractors operating *in parallel*, the shipbuilder (prime contractor for the platforms) and the systems integrator (prime contractor for the combat system). Shipbuilding activity accounts for nearly 60% of the total project cost and systems acquisition and integration for over 40%. The figure highlights an important aspect of complex naval ship construction: the *management of the multi-channel supply chain is distributed between two or more prime contractors*, each responsible for the orchestration/management of construction/integration activities along its particular supply channel. This at once raises a higher-level coordination problem: Defence, through its procurement agency DMO (shown in Figure 2 as a “capability prime”), is now responsible for coordinating the activities of the two (channel-specific) prime contractors. This necessarily implies that Defence cannot (as it has often sought to) adopt and maintain an arms-length relationship with its suppliers. The new model has already been applied in the acquisition of the AWDs via an alliance-based contracting strategy (Australian DoD, 2008). This strategy is given practical effect through an *Alliance-based Target Incentive Agreement* signed in October 2007 by the Defence Materiel Organisation,

ASC as the designated builder and prime contractor for the Navantia-designed AWD platform and Raytheon Australia as the combat system integrator.<sup>66</sup> Defence is also directly involved in the supply chain management as it purchased directly from the US Navy the Aus\$1 billion US Lockheed Martin Aegis combat system, which Raytheon is to integrate with the platform and other on-board systems.

## Competition for Large, Complex Projects

During the second shipbuilding cycle, the competitive conduct of defence naval suppliers was assigned a pivotal role in achieving “value for money” for the Commonwealth and became a mantra of Defence procurement. Competition to take on the role of prime contractor for larger, complex naval projects took the form of rivalry among consortia formed between Australian shipbuilders, overseas designers, and Australian subsidiaries of overseas systems houses. The competitive process led to the award of contracts to successful consortia (e.g., AMEC-Blohm+Voss for the ANZAC Ships) using the conventional model of engagement between the prime contractor and Defence. This mode of engagement had worked reasonably well for projects involving less complex deliverables (e.g., the ANZAC ships). However, as the experience of the Collins project demonstrated, the conventional model based on the arm’s-length relationship between Defence and prime was not suitable for procuring complex capabilities such as submarines or technologically challenging systems upgrades (re: the troubled FFG upgrade). A key reason for the difficulty lies in elements of hold-up present in the relationship between the incumbent prime contractor and Defence.

While competition is normally used to engage prime contractors fronting competing overseas designs, competitive pressure on prime contractors, combat systems integrators and often key OEMs tends to fall away once the prime contract is signed. If the prime contractor fails to deliver contracted performance, slips behind schedule, or runs over the budget, Defence is heavily constrained in its option for remedial action. Switching prime contractors and/or main sub-contractors is often technologically infeasible, financially prohibitive or politically embarrassing. Even for a medium size naval project, such as the FFG upgrade, the prime contractor was allowed to continue with the project, despite public expressions of dissatisfaction from the client and an adverse national audit report. Despite tough rhetoric in public, Defence has only limited scope to bring a contractor into line. A financial penalty for contractual default, for example, may be no more than a slap with the business equivalent of a feather. And, when the worst comes to the worst—as in the case of Rockwell’s failure to deliver the CDS system for the Collins Class submarines—Defence decided against re-competing the requirement and, instead, *appointed* a substitute, Raytheon, to take over as system integrator.

---

<sup>66</sup> The arrangement takes the form of Alliance-based Target Incentive Agreement (ABTIA) between the Commonwealth, represented by the Defence Materiel Organisation, ASC, as the shipbuilder and Raytheon Australia as the mission systems integrator. “The broad AWD procurement principles articulated by the Alliance comprise value for money, efficient and effective process, ethics and probity, accountability and transparency, good faith and fair dealing and *competition*” (Kerr, 2008b, pp. 2-3; our italics). Under this arrangement, major equipment is already specified by Navantia SA—the Spanish designer—and the Alliance will utilise Navantia’s established supply chain. Navantia will perform all the required design modifications and will maintain design configuration control. Raytheon will undertake the Australianisation of the combat system around the fully imported Aegis core sourced by the Commonwealth via the US FMS (2008b, pp. 2-3).

In the third naval procurement cycle, much of the competitive process for major naval projects was completed early on, with winning consortia announced for AWDs and LHDs and large, long-term support contracts for ANZACs and Collins submarines given to Tenix and ASC. It seemed unlikely that any prime contractor would subsequently be dumped and replaced by another contractor. However, there was a key difference between the second and the third shipbuilding cycles. Defence had become aware that lack of effective competitive pressure, following contract award had deprived it of effective market power vis-a-vis its larger prime contractors. The complex, multi-channel procurement model described above can be viewed as an evolutionary adaptation responding to Defence's recognition that, to maximise the likelihood of success for its projects, it would have to embrace fully its ultimate responsibility as "prime contractor of the last resort." It had been obliged to accept that the prospects for shifting project risk to primes in large, strategically important projects were at best limited and, realistically, often unachievable. For successful outcomes, Defence would have to manage projects more proactively and build close, synergistic relationships with primes rather than relying on contract specifications, impracticable penalties for non-performance and arm's-length dealings with contractors.

## Lessons Learnt

In a microcosm of naval shipbuilding activity, this case study shows in detail how various defence industry policies and procurement initiatives have worked in Australia over the past 30 years. By focusing on naval shipbuilding and repair, we have not only selected a sector that is seen in Australia as the jewel in the defence industry crown but also one that comprises a wide variety of business entities—from diversified large contractors to highly specialised small firms, including new forms of government shipyards such as CUFs and technologies such as mechanical (platforms), IT (combat systems, specialised equipment). We conclude this paper by highlighting what are, in our view, key lessons to be drawn from Australian naval shipbuilding experience. These concluding comments focus, respectively, on the demand and supply sides of the market and the demand-supply interface.

### **Demand**

#### *Lumpiness of demand*

For reasons associated with durability, cost and changes in military technology, most defence systems, including those embedded in naval capabilities, tend to be replaced at relatively widely spaced intervals rather than continuously. This applies to simple weapons systems, such as small arms, but particularly to large and chunky elements of capability such as naval ships that tend to be replaced as fleets. This batching of demands can be smoothed by Defence to the extent that fleet replacements can be staggered, but some lumpiness of demand seems unavoidable. Long-term forward plans, such as the Australian DCP, make it easier for industry to anticipate forthcoming demand and ramp up for future tenders. But the scope for demand smoothing is limited as Defence has to be flexible enough in its forward commitments to respond to changing strategic and economic circumstances, sometimes at very short notice.

#### *Asset ownership*

The complete control of "use rights" is necessary for key combat assets such as naval combatants. This can be achieved through the conventional full ownership of ships, or through leasing arrangements, particularly the leasing of vessels from foreign governments.





However, more flexible arrangements can be used to procure the services of secondary assets such as patrol boats, which tend to operate in peacetime in more stable roles and predictable circumstances. As demonstrated by the Armidale patrol boat arrangement, the procurement of ship services from a private consortium of maritime service providers rather than the full ownership of vessels is feasible and attractive. And, in the event of war, the nature of the relationship can be changed by placing the vessels under complete naval control.

### *Local content requirements*

The history of Australian naval shipbuilding and repair highlights often-encountered trade-offs between local and overseas sources of supply and naval preparedness. In Australia, as in other small countries, it is increasingly accepted that building ships in country is politically as much as strategically driven. In modern warfare, there is no time to replace combat assets, such as ships, and nations are unlikely to engage in wars of equipment attrition. It is thus perceived as more important to have domestic industry capability on hand to undertake ship repair and modification, including battle damage rectification. The LHDs project, incorporating hull construction at Navantia's Ferrol shipyard in Spain and superstructure by Tenix in Australia, departs from the recent tradition of building ships in-country to an imported design. However, the procurement of the AWDs follows the conventional path, with expectations that substantial premia will be paid for the political decision to construct them in South Australia (Dodd, 2008).

Australia continues to import naval ship designs and the recent tendency is to minimise design Australianisation (Kerr, 2008a; 2008b). To reduce risks of "design parentage," the approach is to incorporate MOTS components in imported systems and make considerable use of the design authority's established supply chain (e.g., the AWD and LHD arrangements with Navantia). Political pressures are likely to support ongoing high levels of local content in platform construction, but strategic issues may be more important in influencing levels of local content in combat systems maintenance and modification. Defence may be worried about the risk of relying on local supply for developmental components. For example, the locally developed CEA FAR active phased array radar for the AWDs has not been included in the baseline specification as it is still under development by its maker—a small but high profile Australian firm CEA. But, the new technology is likely to be incorporated as it matures (Kerr, 2008b).

### *Business models*

A range of new business models has evolved in Defence to engage suppliers in the most effective way. These models tend to be tailored to the nature of the product and the characteristics of the supplier. When mature products are supplied by established contractors, the inherent risks of performance degradation and schedule slippages are low and traditional fixed/firm price models can be used. An evolved model of this kind has been used to acquire the services of the Armidale Class patrol boats. When the developmental content of the product increases and if the supplier's track record also inspires less confidence, various forms of incentive and incremental contracting are more likely to be used (e.g., the acquisition of the electronic warfare system for the AWDs—Kerr, 2008b, p. 6). And, for technologically sophisticated, complex and politically high-profile acquisitions, such as the AWDs, it is now accepted that the Commonwealth cannot divest itself of its ultimate responsibility for strategic capability formation. In the emergence of the multi-prime contractor model (in which DMO has entered a "prime alliance" with shipbuilder and systems supplier), it has been recognised that the buyer's procurement agency must engage in

*relationship management* and that even a very detailed contract cannot shift all risks away from the Commonwealth to commercial prime contractors.

## Supply

### *Facility ownership*

It was widely claimed in the 1980s and 1990s that privatising government shipyards and factories, and related 'private finance initiatives', was a necessary precondition for their improved productivity and dependability. In 2000s, however, it became increasingly apparent that the private sector would not invest in capital intensive assets such as shipyards unless it could reasonably expect an adequate return on its investment. Commercial owners would only invest in new shipbuilding facilities if their order books justified the heavy capital commitment. This in turn depended on owners' confidence in a continuing flow of potentially profitable orders - hard to create in the face of a history of long intermissions in demand and the competitive processes for allocating work. It has, thus, been recognised that competitive sourcing might have to be abandoned in favour of sole or dual sourcing if local platform builders and maintainers are to be encouraged to invest in capital-intensive facilities. But, it also seems increasingly accepted that *lack of competition and not the public ownership per se* was the main cause of poor performance of government shipyards and factories. The designation of a private contractor as sole source provider to Defence is likely to lead to many problems previously experienced with government-owned enterprise.

As the third post-war building cycle unfolded, the competition between the States for defence orders has resulted in renewed public investment in capital infrastructure in shipbuilding and repair (re: the CUF model was pioneered by Western Australia and adopted by South Australia). And, the Commonwealth of Australia (federal government) has retained its ownership of the Garden Island dock leased to Thales. Under CUF arrangements, governments attract and sustain private naval investment by investing in complementary infrastructure and engaging in a form of quasi-vertical integration under which the publicly owned asset is then leased to a private contractor for the period it requires to supply goods and services to Defence.

The 1990s and 2000s have also witnessed increased penetration of the Australian shipbuilding sector by overseas capital. Of the three largest naval shipbuilders, two (ADI and Tenix) have become subsidiaries of foreign companies (Thales and, subject to satisfactory negotiations, BAE Systems, respectively). The third, ASC, is to be sold in the late 2000s, and may yet end up in overseas ownership. All systems integrators and nearly all major OEMs (except CEA) are subsidiaries of overseas companies. And P&O Maritime Services and Serco Australia have pioneered the provision of fully supported services for minor naval vessels (the Armidales). This trend is very much in keeping with global developments in defence industry. Few small countries can support indigenous systems integrators and OEMs while exporting of defence-related products from small countries poses well-known difficulties.

### *Structure*

The 1990s and 2000s have also seen the increased consolidation of ship assembly in fewer hands and, in a clear break with the past, a growing integration between shipbuilding and repair. In part, the latter trend reflects the changing global division of labour as systems houses and OEMs become increasingly involved in the provision of through-life



support for their products. In part, it also reflects the shift of emphasis in Australian industry policy from a focus on platform construction to through-life capability support. The three large projects of the second shipbuilding cycle have also had implications for the size distribution of firms in the sector. The building of the ANZACs, Collins submarines and Huon minehunters attracted a large number of firms to third-tier naval subcontracting. As a result, the size distribution takes a Pareto form with a small number of large naval firms operating in the first and second tiers, downstream in the supply chain; a large number of third-tier sub-contractors are engaged in the upstream segments of the chain.

### *Conduct*

In the 1990s and 2000s, firms have increasingly made efforts to collaborate along the supply chain rather than to do business with each other at arm's length. On the other hand, firms also appear to have been competing with increasing frequency and intensity for markets opening up for all segments of the naval supply chain. Firms' awareness of their mutual dependence in the network of supply arrangements appears to be driving a tendency to greater collaboration once the principal contract has been awarded.

### *Performance*

The second shipbuilding cycle saw a marked increase in shipyard productivity and less severe budget overruns and schedule slippages. The Collins Class project was the most troublesome acquisition of the period but by no means because of problems restricted to the supply side. The FFG upgrade project appears to have suffered from the classic syndrome of supplier overconfidence: ADI seems to have lacked awareness of its capability limitations and underestimated the importance of technical challenges that were likely to arise in a project of such complexity. As the third shipbuilding cycle unfolded, Defence (and indirectly the government) appeared reluctant to risk quality-budget-schedule outcomes by trying to over-Australianise designs and aiming at high, local-content targets. "Buying MOTS" and minimising the local developmental content characterised its strategy to head off poor performance.

## **Demand-supply interface: Competition for and in the market**

Arguably the most striking development since the end of the second shipbuilding cycle, particularly in the aftermath of the Collins project, has been much better understanding by Defence of competitive processes, especially the difference between *for-* and *in-*the market competition. This reflects the growing maturity of Defence as an investor in new capability elements and buyer of military materiel. It is increasingly accepted that different competitive processes operate for different segments of the naval supply chain. Creating a competitive environment in downstream segments of the chain in a small country calls for opening the market to overseas participants. When this is done, the range of competing designs and combat systems is broadened as overseas consortia of platform builders, system integrators and OEMs (sometimes combining with local firms) come to contest the market. Once a preferred package has been selected, competition in the market follows, and sub-contractors vying for various elements of the package emerge. Domestic subcontractors can be assured a major role in this part of the process if local content requirements are in force.

Finally, it appears that Defence has become more aware of the difference between the pre- and post-contract opportunities open to it in sourcing supplies. That is, it is better understood that, once the contract is signed, switching suppliers and supplies may be



impossible for technological, budgetary or political reasons. As a project progresses through the tendering process, the scope for product and supplier substitution decreases and, for major projects, there may be no realistic way of returning to *status quo ante*. Post contract, competition in the market is largely restricted to upstream segments of the supply chain in which third-tier suppliers are easier to replace if their contractual performance is inadequate.

Also, applying a one-size-fits-all business model can often be a recipe for failure in defence procurement. But, to tailor different models to different acquisitions, it is necessary to acquire good understanding of supply conditions and commercial business processes. Following its designation as a prescribed agency, the DMO has become increasingly professionalised as a procurement agency and as a hands-on equity partner in major acquisition projects.

## Conclusion

Faced with the challenge of efficiently procuring naval vessels of increasing technological sophistication, the Australian government has learned over recent decades that contract arrangements alone are often insufficient to allow it to address and remedy problems, especially when developmental issues are at stake. While fixed-cost contracts, for example, apparently offer the Defence customer the prospect of shifting all risk to its industry suppliers, the experience of the Collins Class submarine clearly showed that when the success of the project was seriously threatened, the government felt it had little option but to intervene directly to re-organise supply-side production arrangements. As the nature of the naval warship has changed with technological innovation, it has also become clear that government must take on an overarching prime responsibility if the production tasks involved are to be effectively coordinated. A warship is a sea-borne platform carrying weapons. But the business of designing and building sea-worthy and battle-ready vessels is altogether different from the enterprise of designing and producing the highly sophisticated, often network-integrated weapons systems that the warship must support. We have shown that the Australian government has recognised the force of this reality by creating different industry primes for platform-building and weapons production and adopting the coordinating role for itself. Despite past rhetoric to the contrary, innovation and complexity in design and production appear to create conditions in which governments find themselves obliged to form close and durable relationships with suppliers if they wish to maximise the likelihood of project success. It may neither be realistic, given the industry structure, nor wise, given the alternatives available to suppliers, for governments to threaten competitive recontracting as their sole, or even principal, means of discipline and performance control.

For political reasons familiar in most countries (smaller ones being no exception), governments routinely find themselves under pressure to favour domestically located supply. If the depth and breadth of expertise and capabilities in local defence industry is limited, there is the potential of conflict with the goals of successfully procuring increasingly sophisticated systems, especially if tailored idiosyncratically to national requirements. As this paper has shown, Australia has at times focused heavily on local content requirements in naval shipbuilding and, whatever the benefits, has sometimes paid a high cost premium for doing so. The issues around such requirements are not likely to disappear in Australia or in other countries in the foreseeable future.

In relation to naval ships, it may appear eminently sensible and potentially efficient to provide sustainment, repair and maintenance for warships domestically but more problematic to justify actually building the vessels in-country. On the other hand, it can be

argued that such a large fraction of through-life costs relate to post-delivery support that any cost premium on domestic construction can be discounted as relatively unimportant. If local through-life support is more efficient when ships are also built locally in the first place, the argument is reinforced. Analogous arguments may also be applied to other sorts of platform and weapons system. No simple generic solution indicates when *make* domestically should be preferred to *buy* overseas in such cases. But the historic experience of substantial cost premia on local content in small country environments suggests that a critical eye should always be applied to *ex ante* predictions of large expected *net* benefits from locally producing the more innovative and idiosyncratic weapons systems.

## List of References

- ADO. (2006a). Defence submission to the senate inquiry into naval shipbuilding. Canberra: Australian Defence Organisation. Retrieved December 10, 2007, from [http://www.aph.gov.au/Senate/committee/fadt\\_cte/shipping/submissions/sub20.pdf](http://www.aph.gov.au/Senate/committee/fadt_cte/shipping/submissions/sub20.pdf)
- ADO. (2006b, August 18). *Defence demand for naval shipbuilding and in-service support*. Defence submission to the senate inquiry into naval shipbuilding, Section 3 update. Canberra: Australian Defence Organisation.
- ASPI. (2002). *Setting a course for Australia's naval shipbuilding and repair industry*. An ASPI Policy Report. Canberra: Australian Strategic Policy Institute.
- Australian DoD. (2008, February). Projects SEA 4000 air warfare destroyer. Retrieved February 28, 2008, from <http://www.defence.gov.au/dmo/awd/sea4000/sea4000.cfm>
- Dodd, M. (2008, January 7). Downsized fleet "the way to go"; Navy cost sinking budget, *The Australian*. Retrieved March 2008, from [www.theaustralian.news.com.au](http://www.theaustralian.news.com.au)
- Hinz, J., & Ziesing, K. (2007-2008). ADM's Top 40: Thales takes top spot in growing Australian defence business sector. *Australian Defence Magazine*, 16(1), 34-35.
- Kinnaird, B., Early, L., & Schofield, B. (2003). *Defence procurement review 2003*. Retrieved March 2008, from [www.defence.gov.au/dmo/dpr/dpr\\_report.pdf](http://www.defence.gov.au/dmo/dpr/dpr_report.pdf)
- Kerr, J. (2008a). Armadales back at work. *Australian Defence Magazine*, Pacific 2008 Insert, 16(1), 30-31.
- Kerr, J. (2008b). Mobilising the naval industry. *Australian Defence Magazine*, Pacific 2008 Insert, 16(1), 2-6.
- McIntosh, M., & Prescott, J. (1999). *Report to the minister for defence on the collins class submarine and related matters*. Canberra: Commonwealth of Australia.
- Parliament of Australia. (2006). *Blue water ships: Consolidating past achievements*. Senate inquiry into naval shipbuilding in Australia, Senate Foreign Affairs, Defence and Trade Committee. Canberra: Commonwealth of Australia.
- Tasman Asia Pacific. (2000). *Impact of major defence projects: A case study of the ANZAC ship project*. Final Report. Canberra: Tasman Asia Pacific, Economic, Management and Policy Consultants.
- Tasman Economics. (2002). *Impact of major defence projects: A case study of the minehunter coastal project*. Final Report. Canberra: Author.
- Tenix. (2001). *Drydocking and shiplifting service*. Retrieved from <http://www.tenix.com/Main.asp?ID=426&ListID=21>
- Walters, P. (2007, March 1). Spain leads for \$7bn navy contract. *The Australian*. Retrieved March 2008, from [www.theaustralian.news.com.au](http://www.theaustralian.news.com.au)



- Woolner, D. (2001). *Getting in early: Lessons of the collins submarine program for improved oversight of defence procurement* (Research Paper No. 3, 2001-02). Canberra: Parliamentary Library.
- Woolner, D. (2006). The air-warfare destroyer: Managing defence procurement. *The business of defence: Sustaining capability* (CEDA Growth No. 57). Melbourne: Committee for Economic Development of Australia.





# Defense Acquisition Policy and Defense Industrial Base Reinforcement Strategy—Enhancing the International Competitiveness of the Korean National Defense Industry

---

**Presenter: Dae Ok Lee**, PhD, is the head of the Administration Management Division within the Agency for Defense Development (ADD). Dr. Lee joined the ADD in 1979 as a researcher in the Ground Weapon Systems Development Center. He served as a project manager of the Tank Development Division, a team leader of the Policy Planning Department, and the head of the Administration Management Division in the ADD.

He holds Doctor of Philosophy in Mechanical Engineering from Jeonbuk National University and a Master of Business Administration from Korea University. He holds a Bachelor's and a Master's degree in Mechanical Engineering, respectively from Jeonbuk National University and Hanyang University.

Dr. Lee has wide research and development experiences in the field of army weapons and has prescribed many technological solutions and policy decisions in that field. He won the Gold Medal of Defense Science Award from the ADD for his contribution on the turret drive and control system of the Main Battle Vehicle. He has published more than 130 research papers on defense research and development. Recently, he has been interested in defense acquisition policy and international competitiveness.

Dae Ok Lee, PhD/MBA, Principal Researcher  
Head of Administration Management Division  
Agency for Defense Development  
Yuseong PO Box 35, Daejeon 305-600, South Korea  
Phone: 82-42-821-3701, Fax: 82-42-821-2223  
E-mail: daeoklee@add.re.kr

---

## Abstract

With the rapid evolution of the global defense management environment, an innovative strategy to reinforce the international competitiveness of the National Defense Industry (NDI) through competitiveness analysis is required. Thus, it is necessary to develop appropriate models for analyzing the Korean NDI and to conduct competitiveness analysis by using the developed model.

For the purpose of analyzing the international competitiveness of the Korean NDI, the researcher reviews the characteristics and problems for various existing models and the competitiveness analysis results for other civil industries. He then compares the attributes of the NDI with civil industries and analyzes the critical technology competitiveness of the NDI for major nations. In addition, he examines the defense policies under the worldwide reform of the defense management environment and the global change of the international defense market.

The researcher develops the Pentagon-Defense 8 Factors (P-D8F) model, a proposed optimum analysis model for the NDI, by applying the results of the analysis for various existing models while considering the unique characteristics of the NDI. He then analyzes the international competitiveness of the Korean NDI by using the P-D8F model, and derives the reinforcement strategy to enhance the global competitiveness for the Korean NDI. Finally, he suggests a possible defense acquisition policy to promote the desired technological innovation and to improve the management environment effectively.



**Keywords:** National Defense Industry (NDI), International Competitiveness, Industrial Cluster, Pentagon-Defense 8 Factors (P-D8F) Model, Defense Acquisition Policy, Technology Innovation

## Introduction

Since the cessation of the Cold War, most nations have focused their energies on enhancing their economic and technological powers instead of on reinforcing their military power. In particular, the powerful military nations—such as the US, France and Russia—steadily carry out various projects, transforming military companies into civil companies. They have also effectively accomplished the military transformation based on the Effect-based Operation (EBO) to transform the defense industrial base (DoD, 2003).

With the rapid transition of the global defense management environment, along with the reinforcement of the WTO system and the increase of global competition, the NDI can't be maintained by the long-sustained government control and support anymore. Many defense companies try to make a good profit and survive in the global environment. For the past 40 years, the government in Korea has played a leading role in producing and supplying military materiel. The NDI has been promoted strongly by government initiatives, but the most advanced military materiel hasn't been researched or developed with domestic technology, capabilities and resources. The critical military technologies haven't been acquired yet, and the international competitiveness of the Korean NDI is very low in comparison with that of developed countries. Therefore, Korean companies don't have the capabilities to research and develop the most advanced weapons to be competitive internationally (Lee, 2007).

For these reasons, a great deal of extensive research must be conducted in an effort to discover the proper strategy to strengthen the international competitiveness of the NDI. However, due to the lack of a competitiveness analysis model, there haven't been any considerable efforts to research or to develop the systematic improvement methodologies to solve the above-mentioned problems. To overcome these problems effectively, an original analysis model, which fully takes into account the defense characteristics based on the civil industries model, is required. Thus, the researcher has developed an innovative analytic strategy for promoting the international competitiveness of the NDI.

The purposes of this study are as follows. The first purpose is to develop and validate the optimum analysis model for the Korean NDI, based on the analytic results for various existing models and the consideration of the NDI's unique characteristics. The second purpose is to analyze and review the international competitiveness of the Korean NDI and to compare it with the competitiveness of the NDIs in other major nations by applying the proposed model. The final objective is to suggest the reinforcement strategy that may enhance the global competitiveness of the Korean NDI.

## Development of International Competitiveness Analysis Model for the Korean National Defense Industry

### 1. Characteristics of the Korean National Defense Industry

The Korean NDI has several different characteristics than do other civil industries or the NDIs of developed countries. First, the NDI is a government-dependant industry



contributing to national security and showing monopolistic and oligopolistic characteristics under government control and support. Second, the NDI is an industry that contributes and enhances the national military power and fosters the national economy. Therefore, its economical efficiency isn't considered, and one-sided investment is mandated by government policy. As a result of this policy, high national economic growth is unintentionally achieved in the confined fields of the shipbuilding, aviation, and automobile industries. Third, the military authorities require the military materiel with the best quality rather than at the lowest cost. And the government controls the demand and supply within the scope of the defense budget and the quantity of each service's request. The law of supply and demand does not work in the NDI. There is always a balance of supply and demand in the market. Finally, excessive plant investment and the long-term diversion of capital from the defense industry are required. Thus, the operating rate is very low, and the quantity is unstable and limited depending upon the government policy and the surrounding environment. It's hard to estimate demand for just 5-plus years.

## 2. Korean Acquisition Process of Defense Materiel

In 2006, the restructuring of the entire acquisition system in Korea was completed. One of the goals of this was to redirect the government acquisition policy to *Defense Reform 2020* (MND, 2005), stressing self-reliant defense based on the Korea-US alliance. Other goals were to pursue the transformation for Technological Forces and to effectively increase the investment in the defense R&D (research and development) budget (6.5% average). The guidelines for this key acquisition reform were to: require transparency, increase efficiency, secure expertise and professionals, enhance competitiveness, and strengthen international cooperation.

Acquisition flow has been reorganized, as shown in Figure 1. Formerly, requirement and procurement were driven by the services (JCS, Army, Navy, and Air Force). The acquisition organizations such as MND (Ministry of national Defense), DPA (Defense Procurement Agency), PMOs (Army-Navy-Air Force Project Management Office), T&EO (Test and Evaluation Office), DQAA (Defense Quality Assurance Agency), and ADD (Agency for Defense Development) weren't well connected organically. The PPBEES (planning, programming, budgeting, execution, and evaluation system) did not work continuously and systematically during the lifecycle of materiel acquisition. The ADD, along with other organizations, used to be at the center of acquisition. Presently, requirements come from services. But the DAPA (Defense Acquisition Program Administration)—into which 8 organizations related to defense acquisition have merged—is now at the center of acquisition, while the ADD has remained at the center of R&D activities.

Figure 2 shows the acquisition process—including the system development flow, which is somewhat similar to that in the US. Requirements come from the services and the MND. After preliminary studies, the DAPA decides the mode of development. Figure 2 also shows the flow of system development from S&T to deployment. Preliminary studies are dedicated to concept development, alternative analysis and interoperability analysis to establish acquisition trade-offs. The exploratory development phase is composed of concept exploration and technology development stages; engineering efforts are dedicated to authorizing the operational concepts and required capabilities and to eliminating technical risks before a program enters the system development phase. The system development phase is composed of system integration and system demonstration stages. Constructive and virtual simulation models are utilized for design and system verification. System and



subsystem performance analysis tools are used for verifying that designs are compliant with the requirements (DAPA, 2007).

The DAPA organization is shown in Figure 3. The Commissioner (at the Vice Minister level) is the head of DAPA. At the next lower level, the Vice Commissioner oversees Acquisition Planning, Defense Industry Promotion, Analysis/T&E, and Policy & Public Relation Management Bureaus. There is also the Program Management Agency, which controls several programs with the help of IPTs.

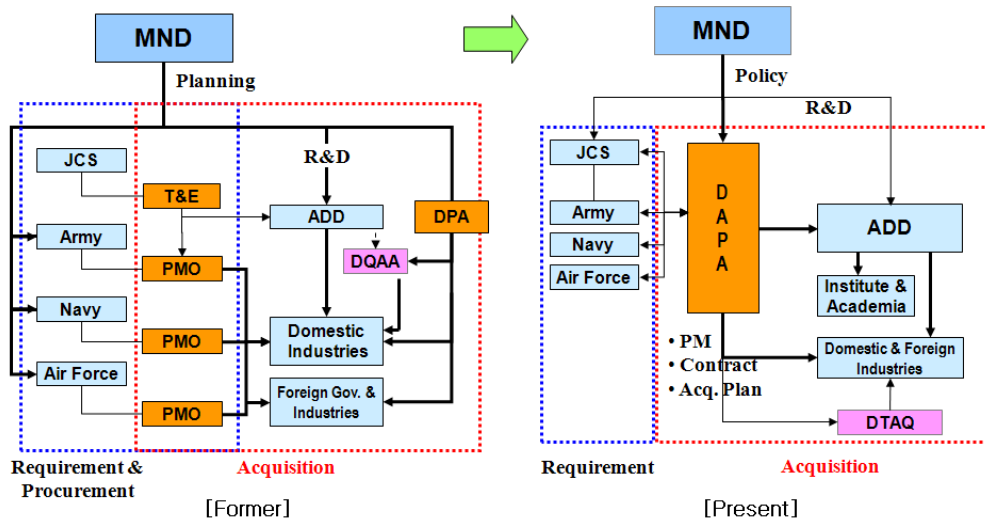


Figure 1. Key Thrusts for Acquisition Reform (Reorganization)

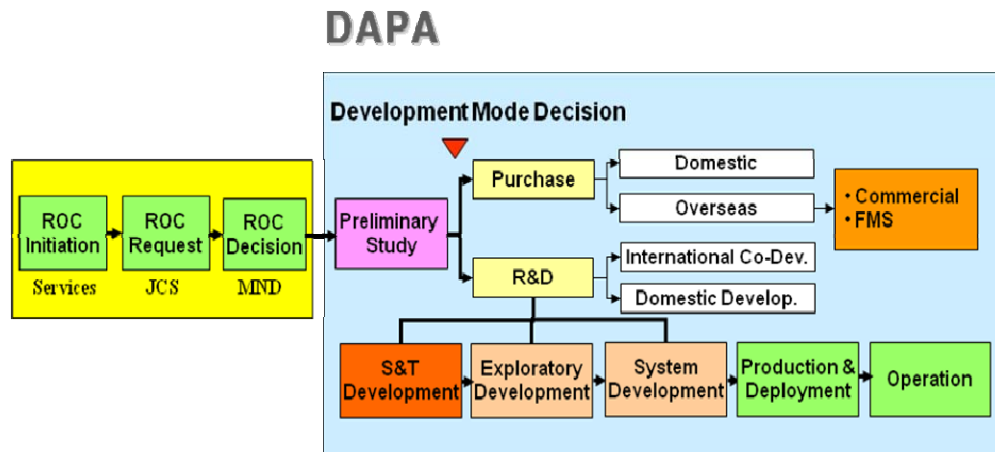
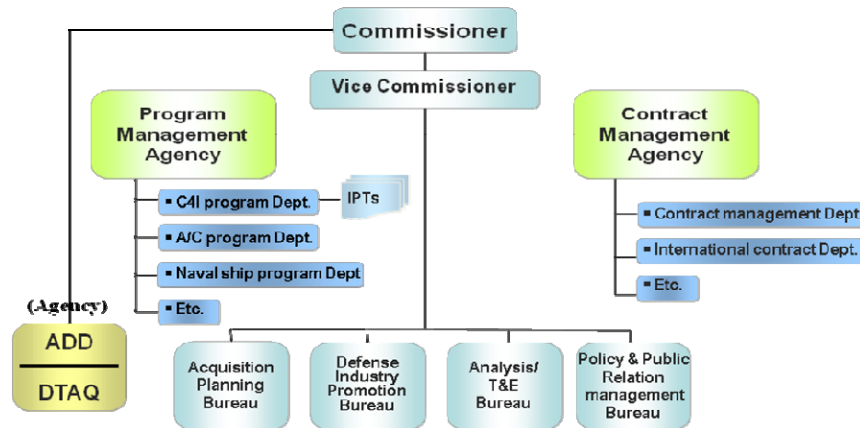


Figure 2. Acquisition Process, Including System Development Flow



**Figure 3. Organization of Defense Acquisition Program Administration (DAPA)**

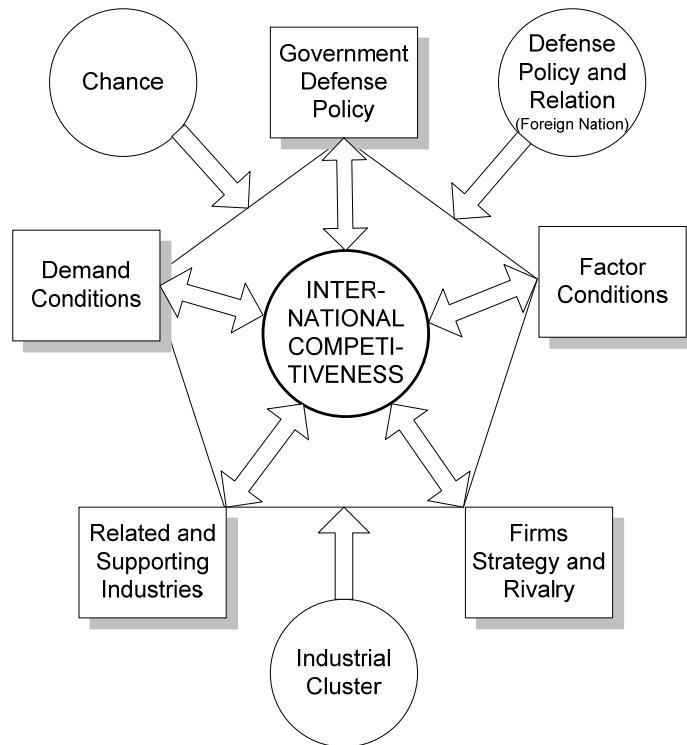
### 3. International Competitiveness Analysis Model for the Korean National Defense Industry

The existing civil competitiveness models (Porter, 1998) are insufficient for analyzing the Korean NDI because of its different characteristics. The rule of market economy doesn't work, as the operations of most firms are under the government's control. In the NDI, the economy system is governed rather by the government-initiated economy than the private-initiated economy. The sole consumer is the government, and the NDI's supply and the government's demand always meet in the market. Government programs, instead of the mechanisms of market economy, decide demand.

As for Korea, all competitiveness factors in the NDI are dictated by the government's intention and policy. The foreign policy and international relations of the major powerful nations, such as the US, China, and other surrounding nations, are also important factors with which to analyze the competitiveness of the NDI. And chance is important because it creates discontinuities and plays its role partly by altering conditions in the competitiveness models. These characteristics must be considered as the optimized models are built (Lee, 2000).

By applying the analysis results for various existing Policy models and considering the unique characteristics of the Korean NDI, the researcher was able to develop the optimum analysis model for the Korean NDI. In case of the Korean NDI, 5 determinants to achieve the national competitive advantages among the nations exist: factor conditions, the strategy and rivalry among the firms, related and supporting industries, demand conditions, and the government defense policy. And 3 influencers of true competitiveness are: the industrial cluster, the defense policy and the relations of foreign nations, and chance.

Figure 4 shows the Pentagon-Defense 8 Factors Model (P-D8F)—with 5 determinants and 3 influencers for competitiveness of the Korean NDI. The factors of the national competitive advantage according to determinants and influencers are shown in Table 1.



**Figure 4. The Pentagon-Defense 8 Factors Model for the Korean NDI**

**Table 1. Determinants and Influencers of Pentagon-Defense 8 Factors Model for the Korean NDI**

Determinants and Influencers		Factors for National Competitiveness Advantage
Determinants	<b>Factor Conditions</b>	<ul style="list-style-type: none"> <li>· Human, physical, knowledge, and capital resources</li> <li>· Infrastructure</li> <li>· Mechanisms creating competitive advantage</li> </ul>
	<b>Demand Conditions</b>	<ul style="list-style-type: none"> <li>· Demand size and pattern of growth</li> <li>· Internationalization of domestic demand</li> <li>· Home demand composition</li> </ul>
	<b>Related and Supporting Industries</b>	<ul style="list-style-type: none"> <li>· Presence of internationally competitive supplier and related industry</li> <li>· Competitive advantage of supplier and related industry</li> </ul>
	<b>Firms Strategy and Rivalry</b>	<ul style="list-style-type: none"> <li>· Management strategy and structure of domestic firms</li> <li>· Vision, goals, and leadership</li> <li>· Rivalry among existing competitors and threat of a new entrant</li> </ul>
	<b>Government Defense Policy</b>	<ul style="list-style-type: none"> <li>· Policies toward defense acquisition and capital market</li> <li>· Product standard and regulation</li> <li>· Capital market regulation, tax policy, and antitrust law</li> </ul>
Influencers	<b>Industrial Cluster</b>	<ul style="list-style-type: none"> <li>· Presence of industrial park and complex, high-technology park, and evolutionary process of cluster</li> <li>· Existence of cluster for several industries</li> </ul>



<b>Defense Policy and Relation (Foreign Nation)</b>	<ul style="list-style-type: none"> <li>· Political decision by foreign government</li> <li>· Variations of international defense environment and military expenditure</li> <li>· Regulations of arms export and technology transfer</li> </ul>
<b>Chance</b>	<ul style="list-style-type: none"> <li>· Invention, technology innovation, and oil shock</li> <li>· Significant shift in world financial market</li> <li>· International dispute and regional war</li> </ul>

## International Competitiveness Analysis of the Korean National Defense Industry Using the Pentagon-Defense 8 Factors Model

### 1. Factor Conditions

In 2007, the Korean NDI was composed of 88 companies producing diverse systems and components of 10 fields of defense materiel. Yet, they show very low operating rates of 50% to 60%, low profit margins of 8.1%, and very low revenue per capita of \$240 million (KDIA, 2007). All data hardly come up to those of Korean civil industries and foreign countries. The international competitiveness of the Korean NDI in the world market is very weak. The continuous-growth strategy must be propelled by defense reform and self-reliant cooperation.

**Table 2. Variations of Operating Rate for the Korean NDI**

Year	1990	1992	1994	1996	1998	2002	2003	2004	2005	2006
Operating Rate (%)	58.2	59.8	56.1	55.7	57.4	54.5	57.3	56.1	57.8	60.6

**Table 3. Productivity & Technology Capability for the Korean NDI in 2005**

Item	Return On Equity (%)	Revenue Per Capita (\$M)	Operating Rate (%)	Tech. Level (%)
Figures	8.1	240	57.8	67
Remarks (civil industries)	12.2	500	79.8	80

Table 4 shows the variations of full-time employees of the Korean NDI. Since 2000, the number of total employees of the NDI has been decreasing gradually due to factory automation and reduction in demand for conventional weapons. Furthermore, expert research engineers are no more than 2,000, 10% of full-time NDI employees. In addition, the number of Korean defense R&D employees in the government—including the associated Institutes and Agency—is just 4,000, quite small compared to 200,000 of the US, 25,000 of Germany, and 18,000 of Taiwan. Lacking expert manpower, the technical level of the NDI can't improve and is still far from that of developed countries.



**Table 4. Variations of Full-time Employees for the Korean NDI**

Year	1988	1991	1996	2002	2003	2004	2005	2006
Number	23,418	27,794	29,640	23,179	23,184	23,007	22,226	20,912

According to the US *Military Critical Technologies List (MTCL)*, which shows country-by-country estimates of the general status of technological capabilities, Korea doesn't retain the critical technologies of Aeronautics Systems, Energy Systems, Sensor and Laser, and Space Systems. On the other hand, Korea's technology levels of Information Systems, Materials, and Nuclear Systems come more or less close to those of the developed countries (DoD, 2004). In this regard, the Korean government tries to enhance its defense technology competitiveness through technology interactions (spin-off and spin-on) with commercial sectors, and lay-out schemes fostering the high technology areas strategically.

The defense R&D budget is about \$1,060 million. That was 4.7% of the defense budget of \$22,513 million and 14.1% of the defense materiel improvement budget of \$7,499 million in 2006 (MND, 2007). It is gradually increasing every year, but the defense R&D budget in 2005 (\$740 million) was quite small compared to major nations—\$82,250 million in the US, \$4,690 million in the UK, and \$4,850 million in France (SIPRI, 2006). The Defense budget in 2006 national GDP is still low; just 2.6% compared with the US, 3.7%, China, 3.9%, and Russia, 4.9% (Hackett, 2007). The defense budget versus the GDP and the defense R&D budget versus the defense budget have to be increased gradually up to developed countries' levels.

**Table 5. Variations of Defense Budget and Defense R&D Budget**

Year	1990	1992	1996	1998	2002	2003	2004	2005	2006
Defense Budget (\$M)	6,608	8,309	12,243	13,800	16,364	17,515	18,941	20,823	22,513
Defense R&D Budget (\$M)	143	235	374	479	723	739	797	929	1,060
Rate (%)	2.1	2.8	3.1	3.5	4.4	4.2	4.2	4.5	4.7

**Table 6. Defense R&D Budget for Major Nations (2005)**

(at constant 2003 prices)

Country	US	UK	France	Italy	Japan	Russia	Korea
Defense Budget (\$100M)	4,782	483	462	272	421	210	162
Defense R&D Budget (\$100M)	822.5	46.9	48.5	6.8	15.2	23.7	7.4
Rate (%)	17.2	9.7	10.5	2.5	3.6	11.3	4.5



## 2. Demand Conditions

Demand is decided within the scope of requirements of the services and the defense budget. It is difficult for the NDI to estimate the demand for even 5 years. The materiel improvement programs of the Armed Forces are established by the MND and the DAPA through a 5-year, mid-term plan. However, the procurement budget is finally set with the adjustment and deliberation of the government (Ministry of Strategy and Finance) and the National Assembly annually. Therefore, it quite restricts the NDI from establishing a mid- and long-term management plan.

Recently, Korean domestic demand for defense materiel has been limited because services want the cutting-edge weapon systems, yet the NDI lacks critical technologies. Industry promotion is restricted due to the insufficient domestic demand, and the creation of a new market is ineffective. The core technology level compared to that in leading countries is 67% in 2004; most areas of cutting-edge technology are even more vulnerable.

Table 7 shows the variations of gross sales of the Korean NDI. Total sales in 2006 reached \$5,452 million—45 times greater than the total sales in 1988, \$120 million. But, the growth rate of total sales (2.5%) is very low compared with the 6.3% of civil industries in 2006. The operating income increases to \$267 million—4 times greater than the \$61 million in 1988. On the other hand, the operating profit margin of 4.9% reaches 5.3% of civil industries, while the ordinary profit margin of 3.0% is lower than 5.7% of civil industries.

**Table 7. Variations of Gross Sales for the Korean NDI**

Year	2001	2002	2003	2004	2005	2006
Total Sales (\$M)	3,705	4,366	4,269	4,644	5,317	5,452
Growth Rate (%)	11.1	17.8	-2.3	8.8	14.5	2.5
Operating Income (\$M)	221	151	154	141	250	267
Ordinary Income (\$M)	-115	25	56	86	149	163

The export of defense materiel by the NDI alone is difficult. To make it possible, the cooperation of the government, military, and the NDI is required. As for the exports of defense materiel, the training and education programs and logistics are transferred to the purchasing country. The establishment of the export marketing strategy by the NDI is restricted because customers are foreign governments.

The number of major conventional weapons being exported and imported is decreasing steadily, whereas the demand for advanced materiel systems is increasing gradually. In 2006, Korea's arms imports amounted to about \$600 million (the 9th largest in the world market), while Korean arms exports were numbered at about \$255 (the 20th largest, taking just 0.2% in the world market) (KDIA, 2007). In the period 2001 through 2005, Korean arms exports ranked the 17<sup>th</sup> largest (\$337 million), and arms import ranked the 9<sup>th</sup> largest (\$2,561 million) (SIPRI, 2006). Thus, this severe imbalance of the trade leads to the shrinking of the Korean NDI. Domestic development of advanced weapons must increase if the defense economy is to improve.

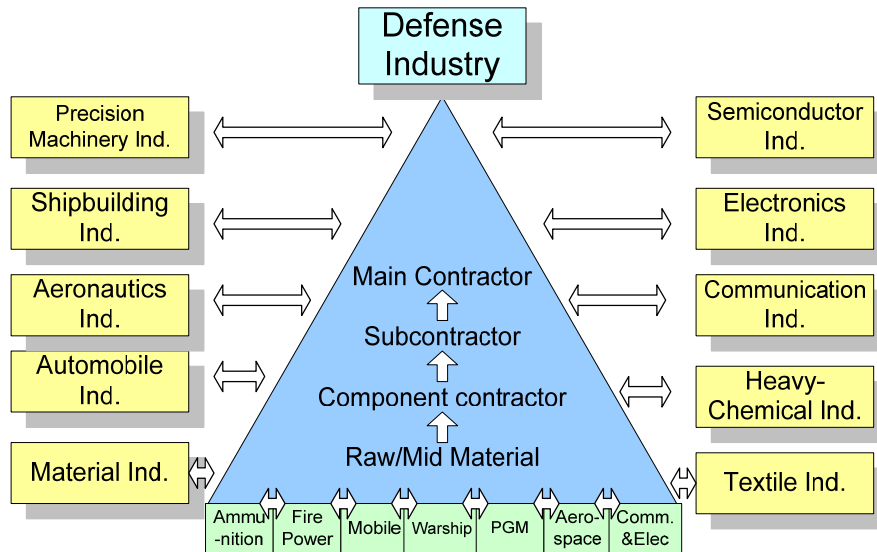
**Table 8. Variations of Arms Export Sales for the Korean NDI**

Year	1991	1995	1999	2001	2002	2003	2004	2005	2006
Export Sales (\$M)	90.6	77.0	196.6	237.2	143.9	240.6	417.8	262.3	255.2

**3. Related and Supporting Industries**

The Korean NDI is composed of 88 main companies, producing the 373 kinds of defense materiel. And 20 to 100 subcontractors work with these main contractors. There are also some defense-related organizations and civil-related industries that interconnect to develop and produce the defense materiel. The Korean NDI is classified into two structures with vertically and horizontally specialized relations. The pyramidal configuration of the Korean NDI is constructed with the vertical relations among main contractors, subcontractors, and components suppliers, and the horizontal relations among weapon industries producing particular weapons such as fire power, automobiles, aeronautics, warship, and missile systems, etc.

Figure 5 shows the pyramidal configurations of related and supporting industries for the Korean NDI. Generally, the vertical and horizontal structure of pyramidal configurations is the best solution to optimizing the effectiveness of the NDI. That is, when the lower members (such as material and component suppliers) are strong and solid, raw materials and components are supplied quickly and inexpensively. This structure has the advantage of maximizing technology development through competitive activities. Furthermore, interactions and exchanges among weapon systems industries in the horizontal structure can foster the competition of other weapon systems industries; likewise, interaction with civil industries can bring out critical technology innovation in civil industries.



**Figure 5. Pyramidal Configuration of Related and Supporting Industries for the Korean NDI**

#### **4. Firms Strategy and Rivalry**

Most Korean defense firms lack competitiveness due to the monopolistic and oligopolistic systems of the Korean NDI. Most defense acquisition programs are still classified, and much information is still limited to the public. The firms have difficulty establishing mid- and long-term management plans due to this limited access to detailed information. The entry barrier of newcomers is very high, and most firms make few efforts to develop the advanced critical technologies.

Defense revenue was only 7.8% of the defense industry's total sales in 2005, and the low productivity of most firms impedes the progress of the defense industry. Firms are faced with excessive financial cost due to their lack of budget compared to initial investment in large-scale R&D projects. Every year, the investment of firms decreases—by \$7.6 million in 2000, \$5.1 million in 2002, and \$4.5 million in 2004.

In this environment, the aggressive management strategy of industries isn't established enough. Entrepreneurs and employers don't formulate great visions and goals for their companies because there is almost no rivalry among existing competitors or threat of new entrants.

#### **5. Government Defense Policy**

Despite numerous attempts to improve the Korean acquisition system, the issues of inefficiency and noncompetitiveness within the defense industry are not yet resolved. In recent years, the government has tried to initiate drastic improvement in defense acquisition policy. The domestic R&D of advanced military materiel takes precedence over overseas acquisition. In addition, the government has tried to establish acquisition plans that ensure the balanced development of advanced military materiel, in accordance with the requirements of the Joint Military Strategy and within the limits of the national budget.

The government has also discontinued the current specialization and grouping system of the defense companies to improve industry competitiveness. Thus, technology innovations among associated companies will be induced. And the technology level of defense companies can be raised up to the level of the developed countries.

The government has endeavored to work in close cooperation with defense companies to enhance exports, and has reinforced the export administration to support them. To help establish vision and goals within defense companies, the government has expanded its disclosure of information on defense investment projects to the public.

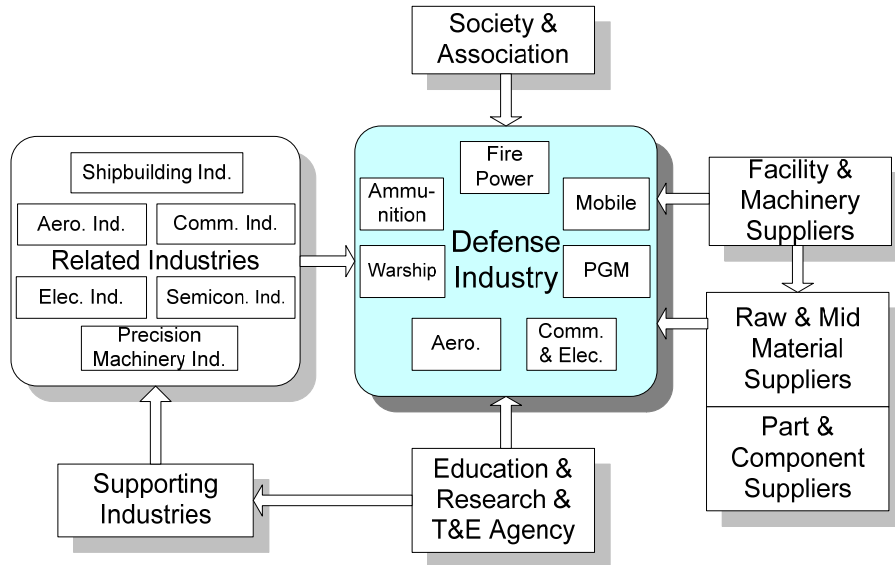
#### **6. Industrial Cluster**

National competitive advantage is generally more remarkable in industrial clusters than in individual industries. Industrial clusters often emerge and begin to grow naturally, such as Silicon Valley in the US. But, in Korea, governmental policy initiated many industrial clusters, such as industrial parks, complexes, and high-technology parks in several areas. The government has established some special industrial and R&D regions by providing specialized infrastructures and technical centers.

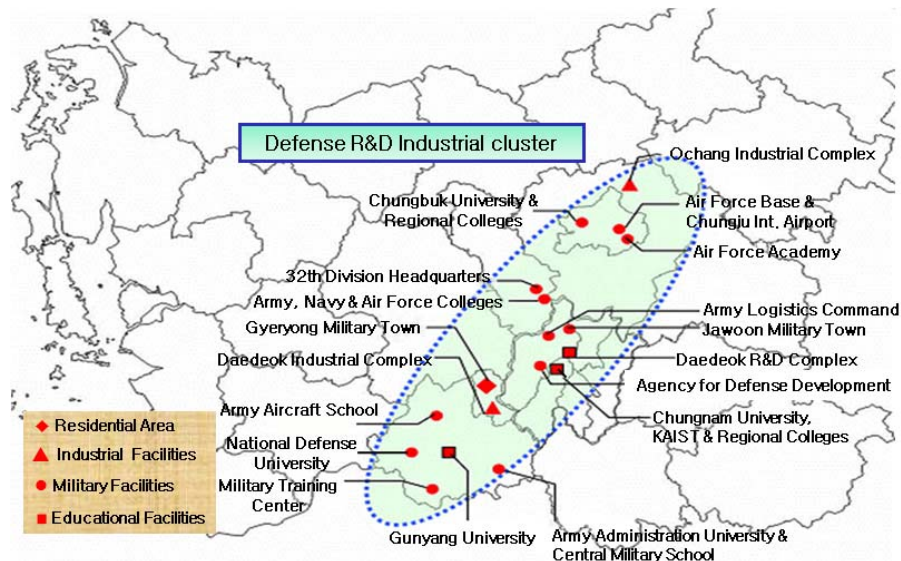
Figure 6 shows one of industrial clusters of the Korean NDI in Changwon City. Related and supporting industries, agencies, institutes, academia, research centers, society



and associations, and suppliers are interconnected to research, develop, produce, and operate the defense materiel. Another type of cluster, the defense R&D industrial cluster in Daejeon City and Chungcheong Province, is shown in Figure 7. It is a unique one in Korea in the respect that most institutes, agencies, and universities related with R&D—in military, government, and civil fields—are centralized in this region. Nevertheless, the Industrial Clusters are not yet complete, as they are not creating the necessary high value-added products due to the lack of the proper establishment of knowledge-based networks.



**Figure 6. Defense Industrial Cluster for the Korean NDI in Changwon City**



**Figure 7. Defense R&D Industrial Cluster in Daejeon City and Chungcheong Province**



## 7. Chance

Chances unexpectedly appear that have little to do with specific circumstances in a nation. They are important because they incur discontinuities that allow shifts in the competitive position. In the history of modern Korean economy, chances that have been particularly important in influencing competitive advantage are as follows: technology innovation, oil shocks, world financial crises, high volatility of exchange rate, international disputes and regional wars. Chances play a role partly by altering the determinants in the Pentagon-Defense 8 Factors Model.

Korea, like other nations, is facing significant changes in its defense outlook. Since the 2000 Joint Declaration (Pyeongyang in North Korea, June 15), South Korea and North Korea have promised proactive exchanges and cooperation. However, the Cold War structure is still lingering, with factors of potential regional friction (such as the North Korean nuclear issue). Countries in Northeast Asia are engaged in constant competition to expand their influence in this region while continuing to make efforts to modernize and transform their military forces.

In recent years, as a result of dramatic development in science and technology, the Korean defense companies have been subject to sweeping changes. There has been also a significant qualitative change in the nature of technology because civil technology has become increasingly important for weapon systems. The technological cooperation of the Korean NDI with civil industries is underway, and it presents the NDI with a chance to enhance its technological competitiveness. The oil shocks greatly reduce the defense budget in energy-dependent nations such as Korea, and downscale the size of the worldwide defense market. However, the US's Global War on Terror and the local wars in the Middle East and Asia have shown the sudden increase in demand.

## 8. Defense Policy and Relation (Foreign Government)

During the post-Cold War period, developed countries have gained military superiority by protecting their national critical technological capabilities. They have significantly increased their defense R&D budget to develop new technologies independently, and have reinforced their control over and prohibit the divulgement of critical military technologies and products to foreign countries. In addition, they have expanded the development of dual-use technology, a spin-on of civil technology and spin-off of military technology.

Most nations control and monitor the transfer of sensitive technologies to other nations while improving the export-control processes to promote and protect their domestic defense companies. With armaments cooperation programs to strengthen their military and industrial relationships, they bind other nations as their partners in strong security coalitions. In recent years, the restrictions of arms export and military technology transfer to competing countries are much more stringent.

To cope with the international defense environment, Korea has increased military expenditures to develop critical technologies independently, and has participated in cooperative programs with foreign advanced companies to introduce and co-develop advanced technology and to foster its arms exports. Korea has even tried to increase its arms exports in order to improve demand conditions within the NDI.



# Defense Acquisition Policy and Defense Industrial Base Reinforcement Strategy

## 1. Enlargement of Defense Budget

Korea's defense budget in its GDP is still low compared to other countries. In 2006, the ratio of the defense budget to the GDP was just 2.6%, obviously quite low compared to other nations' ratios: 3.7% of US, 3.9% of China, and 4.9% of Russia. Most nations engaged in inner- and outer-conflicts usually allocate an average of 5-6% of their GDP to the defense budget. The annual growth rate of Korea's defense budget is expected to increase up to about 9% through 2015, making the budget share out of GDP go up gradually to 3% in 2015 (MND, 2005). However, the budget share has to increase gradually up to the level of developed countries.

In addition, R&D financial resources must be expanded in order to support the acquisition policy. The defense R&D budget has to increase to 10% of the defense budget to enhance the international competitiveness of the NDI in 2015 from just 4.7% in 2007. The dual-use technology programs are reinforced to share effectively the limited defense R&D budget with the civil sectors.

## 2. Reinforcement of Factor Conditions

In planning its acquisition strategy, Korea must give the utmost priority to domestic R&D of Arms if it is to both enhance the critical technology capabilities of the NDI to the level of developed countries, and to raise the operating rate of the NDI to the level of civil industries. The NDI must participate more in R&D if it is to lead advanced arms development and to enlarge its technological capabilities. The ADD also has to be transformed into a core technology and system-of-systems-centric institute, and the NDI's role in developing general weapon systems has to be expanded.

As mentioned previously, the number of expert research engineers within the NDI is just about 2,000. Furthermore, the number of Korean defense R&D manpower under the government side is just 4,000, which is far less than the 200,000 in the US. Due to insufficient expert manpower, the technical level of the NDI cannot be as good as other developed countries. To ensure comparative advantages over developed countries, more expert researchers and engineers are necessary.

## 3. Innovation of Defense Technology

In the US, revolutionary innovations in military technology traditionally come from subcontractors or niche firms, and these firms frequently go on to dominate the markets. These monumental leaps are infrequently developed by the prime firms of their time. This paradigm has been observed frequently in many other industries as well.

In Korea, the ADD has taken the lead in developing innovative defense technology. But, it is difficult for the ADD to play a leading role anymore. The ADD has to cooperate with academia, institutes, research centers, and industries, and to transfer acquired technologies and support them steadily to innovate defense technologies. If necessary, the government has to change the acquisition strategy to ensure a competition-driven innovation. Also, the government must stimulate competitions through incentives, and designate multiple sources



to produce the desired technology. Probably the most important thing for improving and developing innovative technologies is to ensure robust funding.

#### **4. Establishment of Competitive Environment**

The Specialization and Affiliation System that the companies are designated to participate in the acquisition (R&D or purchase) programs was introduced to stimulate technology development and to save financial resources by preventing excessive competition. On account of the excessive preferential authority of designated companies, strong barriers are formed that block new entries and obstruct technological innovation.

To enhance the NID's industrial competitiveness and to induce technological innovation, the above system is expected to be abolished by the end of 2008. On the other hand, in order to promote technological development and efficiency, Korean decision-makers must prepare some criteria and processes to prevent excessive competition and to institutionally ensure the entrances of small- and medium-sized companies.

In addition, reasonable designation and management of defense materiel and companies have to be established; likewise, to promote competition efficiency, appropriate criteria for timing, scope and items in designating the defense materiel have to be set. The government has to prevent inefficiency by reviewing requirements periodically, and must consider appropriate measures to designate and manage the defense materiel and companies for the competitive system.

#### **5. Improvement of Management Condition**

The government should cover some key expenses to help the companies reform themselves and actively carry out additional activities. The supporting funds to promote the competitiveness of the NDI have to be secured, and enough subsidies to develop critical technologies and construct infrastructures of the NDI have to be granted. The cost-based-contract system of defense materiel should be improved to enhance competitiveness for exports by reflecting more expenses.

The government has to establish mid- and long-term strategies to reinforce the industrial base through regular investigation; it must also induce the rational supply system and promote the efficiency of resources through continuous analysis of the defense industry's demand and supply status. The government also has to expand industrial stratum by fostering defense-specialized small and medium-sized business. Small and medium-sized defense firms have to participate in defense R&D. In addition, the government must establish technology-innovation support programs for the small and medium-sized defense firms.

#### **6. Reinforcement of Arms Export Sales**

The establishment of an improved export marketing strategy by the NDI is restricted because customers are foreign governments. Thus, the government-wide networks to support defense exports must be strengthened. Potential and promising items have to be selected and developed to ensure competitive advantages over other countries, and the basis of cooperation among governments has to be strengthened by additional agreements.



Korea's defense imports ranked the 7th to the 9<sup>th</sup> largest in the world, while Korea's export market share was just 0.2% (the 20<sup>th</sup> largest) in recent years. In the period of 2001 through 2005, Korea's arms exports ranked the 17<sup>th</sup> largest (\$337 million), while Korea's arms imports ranked the 9<sup>th</sup> largest (\$2,561 million). This severe unbalance of the trade has led the Korean NDI to shrink. Operational support systems have to be established with trustworthy, importing countries, and measures have to be prepared to enhance price competitiveness—such as financial and tax support. Active cooperation with leading countries also has to be pursued aggressively in order to acquire their advanced systems and technologies.

## Conclusions

This study was conducted to investigate the international competitiveness of the Korean National Defense Industry. The characteristics and problems of various existing competitive models for other civil industries were reviewed and analyzed to develop a new optimized analysis model.

The new analysis model, the Pentagon-Defense 8 Factors model, fully takes into account the defense characteristics that have been derived to suggest the innovative strategy enhancing the international competitiveness of the Korean NDI. As for the Korean NDI, this model is composed of 5 determinants (factor conditions, demand conditions, firms strategy and rivalry, related and supporting industries, and government defense policy) and 3 influencers (defense industrial cluster, defense policy of foreign nation and mutual relation, and chance).

The researcher studied the international competitiveness of the Korean NDI by applying the P-D8F model. He then suggested a possible reinforcement strategy and defense acquisition policy to enhance the global competitiveness for the Korean NDI and to effectively achieve the desired technological advancement.

From this study, the researcher concluded that the proposed analysis model is a useful and practical one for analyzing and enhancing the international competitiveness of the Korean NDI.

## List of References

- Defense Acquisition Program Administration (DAPA). (2007, August). *DAPA acquisition policy*. Yongsan-gu, Seoul: Author.
- DoD. (2003, February). *Transforming the defense industrial base: A roadmap*. Retrieved March 31, 2008, from [http://www.acq.osd.mil/ip/docs/transforming\\_the\\_defense\\_ind\\_base-report\\_only.pdf](http://www.acq.osd.mil/ip/docs/transforming_the_defense_ind_base-report_only.pdf)
- DoD. (2004). *The Military Critical Technologies List*. Retrieved March 31, 2008, from <http://www.dtic.mil/mctl/MCTL.html>
- Hackett, J. (2007). *The military balance*. London: The International Institute for Strategic Studies.
- Korea Defense Industry Association (KDIA). (2007). *Annual management review of Korean Defense Industry*. Seoul: Author.
- Lee, D.O. (2000). International Competitiveness Analysis of Korea National Defense Science Industry. *Journal of International Trade Association*.



Lee, S.J., & Lee, D.O. (2007). Defense transformation and defense policy. *Journal of Defense & Technology*.

Ministry of National Defense (MND). (2005). *Defense reform 2020*. Seoul: Author.

Ministry of National Defense (MND). (2007). *Defense white book*. Seoul: Author.

Porter, M.E. (1998). *The competitive advantage of nations*. New York: Free Press.

Stockholm International Peace Research Institute (SIPRI). (2006). *SIPRI yearbook*. London: Oxford University Press.



## Panel 19 - Exploring the Boundaries of Outsourcing

---

<b>Thursday, May 15, 2008</b>	<b>Panel 19 - Exploring the Boundaries of Outsourcing</b>
	<b>Chair:</b>  <b>Lenn Vincent, RADM USN (ret.),</b> Industry Chair, Defense Acquisition University  <b>Papers:</b>  <b><i>Contracting Out Government Procurement Functions: An Analysis</i></b>  <b>Dr. David V. Lamm,</b> Associate Professor Emeritus and <b>E. Cory Yoder,</b> Lecturer, Naval Postgraduate School  <b><i>The Design Agent Phenomenon: A Post Acquisition Reform Cost-Benefit Analysis</i></b>  <b>Kathlyn H. Loudin,</b> Cost & Affordability Group, Naval Surface Warfare Center, Dahlgren Division  <b><i>The Evolving Private Military Sector: A Survey</i></b>  <b>Dr. Nicholas Dew,</b> Assistant Professor, and <b>LT COL Bryan Hudgens,</b> USAF, Lecturer, Naval Postgraduate School

---

**Chair: Lenn Vincent, RADM USN (ret.)** is the Industry Chair at the Defense Acquisition University (DAU). He uses his Defense and Industry experience, expertise and perspective to advise the DAU management team, OSD, and the uniformed services on matters relative to contracting and program management issues. As a professor at DAU, he presents views to foster a more viable and effective defense acquisition management system. He serves on various DAU advisory councils and its academic review committee. Additionally, he provides independent consulting services to a variety of industry clients relative to procurement, contract management, logistics and supply chain management.

As a Vice President at CACI International, Vincent was responsible for working with senior Department of Defense and Industry leaders to build long-term CACI relationships and to help identify solutions to acquisition, logistics, and financial management challenges. His strategic focus was an initiative to create an integrated digital environment that will extend the DoD's automated procurement system into industry and into the DoD program management offices, in addition to implementation and training strategies for new products and services.

As a Vice President at American Management Systems, he led a 130-member business unit responsible for the deployment and launch of government and industry procurement and contract management software solutions. His acquisition business solutions profit center was responsible for implementing the DoD's Standard Procurement System currently being





used by over 23,000 procurement personnel and for launching of a commercial contract management system for industry, which was purchased by The Boeing Company.

Prior to entering civilian life, Vincent completed a distinguished career in the United States Navy, serving at both sea and ashore. He has over 30 years of broad-based and in-depth leadership and management experience in acquisition, supply chain management, logistics and financial management.

When he retired on August 1, 1999, at the rank of Rear Admiral, he was the Commandant, Defense Systems Management College (DSMC), where he led a graduate-level DoD College with a faculty and staff of 300 people and an annual budget of \$25 million. While in this position, he began an overhaul of acquisition education to include reform principles and technology-based distance learning.

Prior to leading DSMC, Vincent had served as the Logistics, Ordnance and Fleet Supply Officer for Commander-in-Chief Pacific Fleet, where he established policy and coordinated logistics requirements to support supply chain operations in the Pacific Fleet and Indian Ocean.

Vincent was the Commander of the Defense Contracts Management Agency (DCMA), a diverse worldwide organization of 19,000 people responsible for administration and oversight of over 400,000 contracts valued at \$800 billion. Concurrently, he also served as the senior acquisition executive responsible for procurement policy within the Defense Logistics Agency (DLA).

His afloat tours included Supply Officer on both USS Pensacola (LSD 38) and USS Dixon (AS 37). Some of his other shore-based assignments included: Assistant Commander for Contracts at the Naval Air Systems Command; Commander, Defense Contract Management Command International; Commander, Defense Contract Administration Services Region, Los Angeles; Director, Contracts Director at Navy Inventory Control Point, Mechanicsburg; Contracting Officer, SUPSHIP Bath, Maine; and Director, Contracts Navy Supply Center, Puget Sound.

Vincent holds a Master's in Business Administration from George Washington University. He also is a Certified Navy Material and Acquisition Professional, and is *DAWIA* Level III certified in both Contracting and Logistics.

He is President-elect of the National Contract Management Association and serves on its Board of Directors and Board of Advisors. He also serves on the Board of Directors, Navy League National Capital Council; Board of Directors, NDIA Washington, DC, Chapter; Board of Visitors, Defense Acquisition University; Board of Directors, Procurement Round Table; and as a member of AFCEA and AUSA.



# Contracting Out Government Procurement Functions: An Analysis

---

**Presenter: Dr. David Lamm**, Professor Emeritus from the Graduate School of Business and Public Policy (GSBPP), served at NPS as both a military and civilian professor from 1978 through his retirement in January 2004, teaching a number of acquisition and contracting courses, as well as advising thesis and MBA project students. During his tenure, he served as the Academic Associate for the Acquisition & Contracting Management (815) MBA Curriculum, the Systems Acquisition Management (816) MBA Curriculum, the Master of Science in Contract Management (835) distance-learning degree, and the Master of Science in Program Management (836) distance-learning degree. He created the latter three programs. He also created the International Defense Acquisition Resources Management (IDARM) program for the civilian acquisition workforce throughout the country. Finally, in collaboration with the GSBPP Acquisition Chair, he established and served as (PI) for the Acquisition Research Program, including inauguration of an annual Acquisition Research Symposium. He also developed the Master of Science in Procurement & Contracting degree program at St. Mary's College in Moraga, CA, and served as a Professor in both the St. Mary's and The George Washington University's graduate programs.

He has researched and published numerous articles and wrote an acquisition text entitled *Contract Negotiation Cases: Government and Industry*, 1993. He served on the editorial board for the *National Contract Management Journal* and was a founding member of the editorial board for the Acquisition Review Quarterly now known as the *Defense Acquisition Review Journal*. He served as the NPS member of the Defense Acquisition Research Element (DARE) from 1983-1990.

Prior to NPS, he served as the Supply Officer aboard the USS Virgo (AE-30) and the USS Hector (AR-7). He also had acquisition tours of duty at the Defense Logistics Agency in Contract Administration and the Naval Air Systems Command, where he was the Deputy Director of the Missile Procurement Division.

He holds a BA from the University of Minnesota and a MBA and DBA both from The George Washington University. He is Fellow of the National Contract Management Association and received that association's Charles A. Dana Distinguished Service Award and the Blanche Witte Award for Contracting Excellence. He created the NCMA's Certified Professional Contracts Manager (CPCM) Examination Board and served as its Director from 1975-1990. He is the 1988 NPS winner of the RADM John J. Schieffelin Award for Teaching Excellence.

**Author: Commander (Ret) Cory Yoder** is a faculty member of the Naval Postgraduate School, Graduate School of Business and Public Policy (GSBPP). Assigned to NPS in July 2000, he accepted an appointment as Academic Associate (Program Manager) for the 815 (MBA) and 835 (MSCM) programs in December 2002. Commander Yoder has accepted a civilian position at NPS/GSBPP as Lecturer and Academic Associate (Program Manager). Yoder has strong acquisition and contracting experience, combined with several challenging acquisition, logistics, industrial, headquarter, and combat support operations.

Commander (Ret) Yoder entered the United States Naval Service in 1984. Since his commission, he has performed in numerous assignments, including, but not limited to:

- Director and Chief of Logistics, Headquarters, Allied Forces Southern Command (AFSOUTH), Naples, Italy (logistics, contracting, finance within NATO)
- Post Commander and Support Group Commander, Kosovo Verification Coordination Center (KVCC), Kumanovo (Skopje), Macedonia
- Officer-in-Charge, Fleet and Industrial Supply Detachment, Long Beach, California
- Stock Control Officer, USS TARAWA (LHA-1)



- Aviation and Surface Stores Officer, USS TARAWA (LHA-1)
- Naval Acquisition and Contracting Officer (NACO) internship, Naval Regional Contracting Center (NRCC), Washington, DC
- Supply Officer, USS FANNING (FF-1076)

CDR (Ret) Yoder holds the following degrees and certifications:

- MA in National Security and Strategic Studies, Naval War College (NWC), Newport, Rhode Island, 1997
- MS in Management, Naval Postgraduate School, Monterey, CA, 1993
- BS in Business Management, Indiana University "Kelly" School of Business, 1983

CDR (Ret) Yoder is professionally certified and/or a member of:

- DAWIA Contract Level III certified
- Institute for Supply Management (ISM), Direct National Member
- Beta Gamma Sigma international honor society for graduate degree holders

Cory Yoder  
Lecturer  
Graduate School of Business and Public Policy  
Naval Postgraduate School  
Monterey, CA 93943-5197  
Tel: (831) 656-3619  
E-mail: [ecyoder@nps.edu](mailto:ecyoder@nps.edu)

---

## Abstract

The Deputy Assistant Secretary of the Navy for Research, Development & Acquisition (DASN (RDA) (Acquisition Management)), asked the Naval Postgraduate School (NPS) to analyze the contracting out of procurement functions currently being accomplished by Navy, Marine Corps, and other Department of Defense (DOD) Activities. The request specifically focused on assessing the degree of effectiveness and shortcomings of such contracting out efforts. This research sought to answer these questions: Which contracting functions are now being contracted out by Navy and other DOD organizations? How effectively have contractors performed on these contracts? What metrics are being used and could be used to assess the quality of contractor performance? Although the primary focus of this study is the effectiveness of contracts used to procure contracting services, several interrelated subjects have been explored. Aspects of inherently governmental functions, personal service relationships, conflicts of interest, and legal/ethical issues were included. Further, questions regarding the impact on the contracting system, the development of Contracting Officers, the participation of competing companies in the marketplace, training and experience qualifications, and agency procurement decision-making and policies were also examined.

## Introduction

Several factors have led to an increased reliance upon the private sector to provide services. One of the most critical factors has been the lack of adequate numbers of civil servants to perform the functions required of buying organizations. The number of DOD employees has been significantly reduced due to retirements or transfers to other agencies



and, in certain metropolitan areas, the number of qualified applicants available to fill vacant positions has fallen to a seriously low level. Another of the principal factors has been to reduce the cost of providing services. With competition and a more efficient process of producing services, it is widely believed that significant savings have accrued. Another factor has been the ability to obtain certain skills which the Government does not possess. This has become more critical as agencies have reduced the size of their workforce. Yet another factor is to obtain services on an emergency or surge basis. DOD has come to rely more and more extensively on service contractors during military conflicts. For these reasons, some organizations have begun to contract out selected contracting functions associated with the acquisition process. Further, some have actively promoted contracting out efforts and see this as an integral part of their corporate strategy. But, for various reasons explored herein, some organizations have taken no action to contract out procurement functions.

## Methodology

Sources involved in acquisition research were consulted, including the following: reports issued by the Government Accountability Office (GAO); theses and master's degree projects from students at the Naval Postgraduate School (NPS) and the Air Force Institute of Technology (AFIT); student reports from the Naval War College, Army War College, and Air War College; reports and studies from the RAND Corp., the Project on Government Oversight (POGO), the Defense Science Board (DSB), the Contract Management Institute (CMI), the Professional Services Council (PSC) and the Logistics Management Institute (LMI); papers presented at the NPS Annual Acquisition Research Symposium; and student and faculty reports from the Defense Acquisition University (DAU) and the University of Maryland. Various periodicals were examined, including the *Defense Acquisition Review Journal*, *Contract Management*, *Defense AT&L*, and the *Journal of the National Contract Management Association*.

Two survey questionnaires were used. The first focused on participants at the policy and senior management levels and asked questions about the broader issues involved in contracted procurement services. The second survey focused on management and operating level personnel and, although some of the same questions on the first survey were also posed, it mainly asked questions regarding the effectiveness of contracts that are being or had been used to procure contracting support services. Surveys were completed by a total of one hundred contracting professionals and thirty-two program management and technical personnel. A comparison of organizational affiliation and category of survey participants is presented in Table 1. All thirty-two program management and technical personnel are from the Air Force located at Tinker Air Force Base, Oklahoma. In some instances, the senior managers of a major acquisition organization provided collective views. Thus, the number of individuals participating in the survey are greater than the number of questionnaires received.



**Table 1. Survey Participants**

<b>Organization</b>	<b>Policy and Senior Management</b>	<b>Management and Operating Level Personnel</b>	<b>Total Survey Participants</b>
Army	5	11	16
Navy/Marine Corps	18	17	35
Air Force	5	2	7
Defense Agencies	13	25	38
Non-Federal Agencies	4	0	4
Air Force Prgm Mgmt & Tech Personnel	0	32	32
<b>Totals</b>	<b>45</b>	<b>87</b>	<b>132</b>

Personal (face-to-face) interviews were conducted with nineteen senior contracting personnel (over 80% of whom are from the Navy Department) many of whom also completed a survey. Phone interviews were conducted with fifteen individuals and generally included those who had indicated willingness on their survey responses to clarify or expand upon their answers. Throughout the study, the terms “procurement” and “contracting” are used interchangeably, as are the terms “function,” “task” and “duty.” The terms “contracted services,” “contracted support services” and “procurement services” refer to those contracting functions or tasks that are typically performed by civil servants and are now, or could be, performed by contractor employees. “Outsourcing” refers to accomplishment by contractors and does not include other Federal Agencies. This research work was undertaken with the intent of exploring and evaluating only those actions and efforts taken by the Government in the buyer-seller relationship. Although there are a significant number of companies that provide contracted support services as well as industry and professional associations that have intimate knowledge and understanding of the process, the present research was limited to the issues and problems experienced only by Government personnel.

A few situations arose which impeded the numbers of surveys and interviews that might otherwise have been obtained. One situation was the impression that this study was looking for those contracting functions which could be prime targets for contractor performance, which in turn could lead to a reduction in contracting workforce personnel. A second situation occurred in which agencies are contracting out some functions that other agencies consider to be inherently governmental, and those agencies’ officials felt that they would be criticized for having placed these functions on contract. A third situation involved a general feeling that top agency management was against placing contracting functions on contract, which made our study a moot point. Lastly, some organizations simply said they were too busy to participate in the research.

## Discussion

### **Inherently Governmental Functions**

Survey questions concerning inherently governmental functions (IGF) focused on whether respondents were aware of any functions considered to be inherently governmental or exempt from competition that are, in fact, being contracted out and the extent to which



capability deficiencies forced organizations to identify their interpretation of inherently governmental. Also, from a very limited list of functions, survey participants were asked to distinguish those they felt were inherently governmental as opposed to those that were not. Forty percent of the respondents stated that a capability deficiency had caused their organization to assess whether or not a contracting function was inherently governmental. The shortage of Full-Time Equivalents (FTEs) due to various forms of attrition has been exacerbated in recent years. Retirements and personnel transfers with the resultant loss of corporate knowledge and expertise have forced organizations to rethink their position regarding tasks contractors can perform. The 60% that said they had not made this assessment are from organizations that long ago decided that certain contracting tasks were non-IGF and were placed on contract, had decided the entire function is off limits to contracts, or had sufficient resources to meet workload demands. When asked if they knew about inherently governmental functions being contracted out, slightly fewer than 20% acknowledged that this is happening. Although this may seem like a small number, it points out that there are functions being acquired on contract that some view as violating the rules. A large part of this could be due to the disparity between those who believe that some contracting tasks are IGFs and those who do not.

Policy survey respondents were presented with a limited list of contracting functions and asked to classify them as either IGF or non-IGF. From the replies, three categories were established: (1) “unanimously” or predominantly IGF, (2) predominantly non-IGF, and (3) “middle ground.” Table 2 displays the three categories.

**Table 2. Senior Contracting Personnel Views of Inherently Governmental vs Non-Inherently Governmental Functions**

<b>Predominantly Inherently Governmental</b>	<b>“Middle Ground”</b>	<b>Predominantly Non-Inherently Governmental</b>
Requirements determination		
	Developing Statements of Work	
	Structuring market research	
		Conducting market research
	Performing acquisition planning	
	Developing solicitation documents	
	Issuing solicitation documents	
	Developing and applying evaluation criteria	
	Member of Source Selection Evaluation Board	
	Evaluation of proposals/offers	
	Performing cost and price analysis	
Negotiating contract prices, terms & conditions		
Structuring & approving incentive plans		
	Preparing price negotiation memoranda	
Awarding contracts		
Negotiating contract modifications		
Determining cost allowability		
Exercising options		
	Assessing contractor performance	
Implementing action based on		





contractor performance		
Accepting or rejecting goods & services		
Terminating contracts		
		Preparing contracts for closeout

If no more than 75% or no fewer than 25% selected a function as either IGF or non-IGF, the function was placed in the “middle ground” and open to interpretation. All of the IGFs involve some type of Contracting Officer determination and/or decision which are considered by almost everyone to be within the Government’s purview. The two functions identified as essentially non-IGF have been performed by contractors for several years and now seem to be the accepted norm. The “middle ground” functions are basically the area of debate. Functions listed close to the left of the box received the majority of IGF responses, while those functions close to the right received the majority of non-IGF responses. Structuring market research is closely related to conducting market research and developing solicitation documents is often distinguished as a support effort. These two functions could have easily slipped into the non-IGF category. Performing cost and price analysis is the function that seems to generate the most heated debate. Many believe it to be integrally involved in either the negotiation process or a Contracting Officer’s determination of price reasonableness, or both, and should not be contracted out. Further, considered by several to be a core capability, it is also judged to be one of the weakest skills held by the Government and badly in need of significant training and hands-on experience. Although tending toward the IGF side, acquisition planning, evaluation of offers and preparing price negotiation memoranda are just as easily viewed by many as non-IGF.

### Personal Services Relationships

Over 85% of the respondents felt that there are potential problems with personal services relationships when contracting for procurement services. On the one hand, there is an overwhelming feeling that contractor employees need to be co-located with Government contracting personnel in order to effectively accomplish their work. On the other, this close proximity presents the very ingredients that lead to personal services situations. Many of the respondents felt that because Government and contractor specialists had to work together so intimately, such a relationship was inevitable. Not directly causing a personal services dilemma but linked to the close working relationship are the circumstances involving “acceptance” of the service or work product performed by contractors. Products or goods have a very definitive acceptance or rejection process that requires specific Government action. Services do not have similar acceptance procedures. In the case of contracting functions, who accepts the contractor’s work product and how formal is the process? If the Government proceeds to use work packages submitted by contractors, de facto acceptance has probably occurred without an overt action. At this point, the Government could certainly be liable for the decisions made based on the contractor input that might later prove to be faulty and damaging. None of the respondents voiced an opinion that the prohibition on personal services contracts should be eliminated; however, if asked, it is suspected that a majority would willingly agree with the removal of certain aspects of the personal services restriction.

### Conflicts of Interest

Survey participants responded with numerous conflict of interest situations they believed could easily occur unless precautionary measures were instituted. Access to company proprietary and business sensitive information, competing in cases where firms



participated in developing requirements, an actual or perceived ability to influence procurement actions, biases against certain companies for obvious or even unknown reasons, insight into the Government's requirements process, mergers and acquisitions that cause questionable affiliations, and other similar opportunities to inappropriately affect Government procurement were cited as potential problems with contractors. Some respondents remarked that conflicts of interest could also easily occur with civil servants working so closely with contractor employees. Differences in compensation, future employment opportunities, and personal friendships with contractor employees that may even have originated when both worked for the Government were observed as some of the conflict of interest situations in which civil servants could easily become embroiled. A recent Government Accountability Office (GAO, 2008) report concluded that when contractors are performing duties closely supporting inherently governmental functions, risks exist that could result in loss of Government control and decision-making. The Government and contractors are both responsible for ensuring that measures are in place to prevent conflicts of interest.

### **Legal and Ethical Issues**

This research asked if there are any legal issues or impediments to which over 85% responded in the affirmative. Respondents are concerned about three primary areas: (1) violating the prohibition against placing inherently governmental functions on contract, (2) averting personal services relationships, and (3) avoiding conflicts of interest. They state that proper non-disclosure agreements, financial disclosure statements, and vigorous application of safeguards and security mechanisms are critical to prevention. It is well known that civil and criminal penalties await Federal employees if they violate statutes prohibiting unethical and improper behavior in the execution of their responsibilities. This is generally not true if contractor employees performing procurement functions for the Government act in this manner. Several situations concerning contractor personnel involved with financial conflicts of interest, impaired impartiality, misuse of information, misuse of authority and misuse of Government property have transpired. There has been some discussion about the suitability of changing the laws to make them applicable to contracted employees when they are working on behalf of the Government. Some suggest that instead, contract clauses should incorporate such requirements. At the very least, contractor personnel should be held liable and accountable for actions taken in their capacity as "Government agents." Whether this is accomplished statutorily or through contractual clauses, some action in this direction is absolutely crucial.

Ethics was brought up on the Policy and Senior Management questionnaire and a significant majority of the respondents believe that ethical issues are associated with contracting for procurement services. To some, this took the form of organizational conflicts of interest while to others it involved contractor access to procurement sensitive information and the opportunity to take unfair advantage of the system. Most of the respondents expressed concern about contractor loyalties and motivations which might impair their objectivity and impartiality when acting as an "agent" for the Government. The judgment and interpretation of the laws and regulations by Government employees should not be replaced by contractor personnel. The best interests of the Government should be foremost in any action taken by someone in the contracting process. Misgivings can easily arise when contractor employees take these actions. Trust in the system can be easily and seriously jeopardized.



## Procurement Functions Contracted Out

Over recent years, the numbers and types of functions contracted out has greatly increased. Some organizations have become concerned that too great a percentage of workforce positions are filled with contractor employees and have begun to develop plans to reduce that percentage. Close to 60% of survey participants indicated that at least some procurement functions are being contracted out. Policy and Senior personnel have fewer situations of contracting out while Management and Operating Level Personnel are predominantly from organizations that are contracting out procurement functions. When isolating the Defense Agencies from the Services and others, however, that number exceeded 85%. When looking only at Navy and Marine Corps organizations, that number dropped slightly below 35%. These findings are consistent with other studies, which found the Defense Agencies with the highest ratio of contracted support services and the Navy and Marine Corps with the lowest. When asked which functions are involved, contract closeout was identified with the greatest frequency. This was true for all Services and the Defense Agencies. Policy and Senior Management personnel tended to cite market research, acquisition planning, drafting policy, developing evaluation criteria, evaluation of offers, and requirements development as the predominant functions contracted out. Some policy/senior personnel did state, however, that all functions performed by 1102s, except for inherently governmental functions, are placed on contract. The percentage of Management and Operating Personnel who reported functions contracted out in their organizations was much higher and included all contract specialist functions in support of the Contracting Officer in both pre-award and post-award phases. Most were careful to explain that the approvals, determinations and decisions made by Contracting Officers were not included.

The most prevalent reasons cited for contracting out are the lack of organic resources to meet workload demands and the lack of needed skills or expertise in certain areas. The continual downsizing and freezes on hiring new personnel over the last several years, together with an increase in the workload, has severely strained the contracting community. In certain geographical areas, there is constant turnover and an inability to fill 1102 vacancies with qualified applicants. In some cases, contractors are used to obtain exposure to business concepts and insight into commercial practices and technology. Some stated that hiring contractors is generally easier and faster than trying to obtain Federal employees through the cumbersome civil service personnel process. Contractors provide greater flexibility in adjusting to workload fluctuations, particularly due to surge situations. They can also provide continuity to those cases in which organizations are experiencing a very high turnover of contract specialists.

The most common reason for not contracting out procurement functions is that the organization believes all aspects of contracting are inherently governmental. Even if the organization did not consider contracting inherently governmental, there was a preference against contracting out, especially if interchangeability of personnel or adaptability was threatened. In smaller offices, Contracting Officers are performing most contract specialist functions that would be difficult to untangle from their decision-making functions. In some cases, the organization claimed that sufficient resources existed to meet workload requirements or that outsourcing the functions did not provide any additional advantages. A few organizations indicated that the potential for conflicts of interest or other ethical problems had steered them away from using contractors. In a couple of cases, respondents felt that contractors were more expensive than Government employees. One scenario that has been cause for concern is contractor default. Buying offices that have turned over contract specialist workload to contractor employees may be in a difficult situation if the



contractor is terminated for default. It would be arduous to explain to the buying office's customers that procurement actions are delayed because the contractor(s) defaulted. If a significant portion of that office's workforce consisted of contractor employees, the added burden may be too overwhelming for the civil servants in the office.

## **Effectiveness of Contracted Services**

Management and Operating Level Personnel expressed overwhelmingly that contracts for procuring contracting functions were highly effective or somewhat effective. A deeper analysis of the results, however, shows that most of the respondents indicating a positive effectiveness of contracts based their evaluation on a simple objective set of metrics. First, did contractor performance allow the command to meet its mission, and second, was overall performance good enough to consider the contractor for future work. The heart of the rudimentary metric gets at the most basic rationale for contracting out any function, getting the job done and doing it satisfactorily. Responses are based primarily on criteria that find their basis in whether the contractor allowed the activity or business unit to achieve its mission or productivity goals, and additionally, whether the contractor had any significant performance problems that would preclude them from being considered as a candidate for future award of similar work. No other criteria for measuring effectiveness were being systemically applied. What is challenging for contract managers is that metrics are difficult to capture in any detailed objective format. The subjective nature of this type of assessment by the population surveyed is very common. It is, however, a measure that can be captured by Past Performance Information (PPI) systems, and the Contractor Performance Assessment Reporting System (CPARS) currently in use within DOD.

## **Limitations on Effort Contracted Out**

Three aspects of limitations on contractors performing procurement functions were explored: (1) the duration of contracted support effort, (2) whether contractors should be physically located with Government personnel performing the same tasks, and (3) percentage limitations on the amount of procurement effort that could be contracted out. The first area was presented on the policy survey while the latter two areas were presented on the management/operating level personnel surveys.

### **Duration**

Over 60% of the respondents believed these contracts should be of a temporary nature. Organizations which tended to currently have more procurement functions contracted out were split over the idea of temporary versus permanent. The proponents for temporary contracts felt it should only be used for surge or emergent requirements while the Government recruits and trains organic resources. Those advocating a more permanent duration felt it will be several years, if ever, before Government resource requirements are met, thus a lasting contractual relationship should be established. Some feel that certain tasks, such as contract closeout, have such a low priority they might never be appropriately completed without contractor support and should be made permanent regardless of in-house resource levels. It appears to the researchers that almost all the reasons cited in the *Federal Acquisition Regulation (FAR)* as valid alternatives for the use of advisory and assistance services (A&AS) contracts seem to imply temporary situations. Obtaining advice, points of view, opinions, special knowledge, alternative solutions, support to improve operations, and assistance with more efficient and effective operation of managerial or hardware systems all give the impression that agency management would acquire these



“consultant” services on an as-needed basis. Further, the language does not give the impression that the performance of routine tasks on a day-to-day basis is the intent of employing this capability. If management policy is to utilize contracted support only if we must, then certainly all contracts for this support should be viewed as temporary until no longer required. If management policy is to leave this up to each individual organization to decide, then the types of functions they perform and their overall view of the procurement responsibility will drive their choice.

### **Co-location**

Closely related to the matter of personal services relationships during contract performance is the location of contractor employees when they are carrying out their duties. An overwhelming 75% majority of respondents emphatically expressed the need for close communications on a face-to-face basis between all members of the acquisition team. The professional interaction that will occur through physical proximity outweighs any risks that might surface. The day-to-day working conditions requiring communication, efficient interaction, responsive feedback/input, and professional interface to advance learning and understanding all support a blended workforce. Past attempts at separation have shown this to severely hinder smooth accomplishment of the contracting functions. The 25% who said contractor employees should not be in the same spaces as civil servants were not denying the benefits of personal interaction but rather were implying that the risks are more than should be accepted. Access to sensitive and proprietary data, security considerations, and the potential for conflicts of interest was of real concern. Personal service concerns appear to be diminishing.

### **Percentage of Contracted Services**

The last area related to restrictions on the extent of contractor participation is the idea of confining the percentage of effort that activities can place on contract. A Defense Acquisition University (DAU) report recommended that each contracting activity be limited to no more than 25% of their workforce that may be contracted out. The researchers decided to ask not only where the percentage limitation on the workforce should be established, but also what percentage of the workload should be limited to outsourcing. Regarding workforce, just over 50% of the respondents said that it should be under 25% and the total reaches three-fourths of the respondents when one goes to a 50% limitation. Just over 45% of the respondents believe that contracting out should be constrained to under 50% of the total workload while that percentage increases to 65% if half of the workload is the limitation.

### **Experience and Training Requirements**

The DOD acquisition workforce has been criticized over the years for its lack of skills, knowledge and abilities to execute its responsibilities. The Report of the Commission on Government Procurement, the Packard Commission report and several other studies from similar groups have pointed to the need for a professional workforce meeting minimum standards established for education, training and experience. Recommendations from these studies served as the impetus that created the *Defense Acquisition Workforce Improvement Act (DAWIA)* and led to the standards in place today. It would be justifiable to expect that anyone performing contracting functions for DOD should meet these standards and qualifications. Should this expectation be extended to contractor personnel performing procurement functions for the Government? And if so, how difficult would it be to impose and enforce DAWIA standards on contractors? This was the issue explored in both surveys.





The Policy and Senior Management survey asked about DAWIA implications and whether DAWIA should be imposed on contractors, while the Management and Operating Personnel survey queried participants as to the level of difficulty encountered if an attempt were made to compel contractors to comply with DAWIA. Seventy percent of the policy survey respondents felt there are DAWIA implications whereas about 65% felt that DAWIA or DAWIA-like requirements should be imposed. Forty-five percent of the management/operating personnel said it would be difficult or very difficult to impose and enforce DAWIA requirements, while, in contrast, over 45% noted that it would be easy. Although not an overwhelming majority, most participants felt that DAWIA is important to the issue of using contracted employees.

The argument for application of DAWIA includes the beliefs that these requirements are critical elements in the performance of complex functions to ensure individuals have the ability to think logically, act competently, stay current in the field, meet contractual expectations, and perform in a proficient manner. Proponents believed that contractors should be held to the same standard of competence as DOD personnel. Those opposing application of DAWIA claim: it will cost the Government an additional expense for contractors to meet the standards; most contractor employees are former Government personnel and probably already have these certifications; DAWIA is a statutory requirement placed on the Government and not industry; some are already using DAWIA standards as an evaluation criterion in source selections or use DAWIA language in statements of work to describe desired labor categories, and it will inhibit competition. There appear to be valid arguments on both sides. It seems as if the argument for DAWIA focuses primarily on the level of skills and competencies personnel should hold, while the argument against mainly suggests that DAWIA qualifications are already being used to a certain extent and to push any further would be costly to the Government. One might conclude that if DAWIA is already being used in this environment to one extent or another, full application of this qualification should not be a difficult stretch. Further, although there may be added expense to the Government to bring contractor employees up to a certain level of competence, failure to do so may be even more costly in the less-than-satisfactory performance of contracting functions, even though there might be Government oversight.

### **Impact on the Contracting System**

The research examined the affect contracted procurement services might have on the contracting system by looking at three aspects: (1) the development of future Contracting Officers, (2) the development of procurement options by agency management, and (3) the extent to which companies might not want to participate in Government procurement. The first two areas were addressed on both surveys while the last was asked only on the policy survey.

#### **Contracting Officers**

Over 65% of the respondents felt that contracting out procurement functions could have a damaging impact on the development of future Contracting Officers, slightly over 20% felt it would not have any affect, and less than 10% thought it might have a beneficial impact. Respondents believing a damaging impact could occur pointed to the critical need to nurture and cultivate a competent and professional workforce. Significant contract specialist experience is needed to progress through the basic and intermediate levels to ultimately reach the advanced and expert proficiency levels required of Contracting Officers. One needs to be exposed to the broadest cross-section of contracting tasks that permits





development of the critical thinking skills and competencies so fundamental to making complex Contracting Officer decisions. It was argued that contract specialists need to experience the various avenues one might pursue in accomplishing a particular objective. They need to grasp the underlying mechanics and inner workings and, in fact, they need to fail from time-to-time to discover the weaknesses and risks surrounding particular courses of action. They need to rotate through various assignments in contracting to undergo and be exposed to the specific facets these duties offer. Contract specialists need to be mentored. Not only must they eventually acquire strong managerial skills but they must also develop leadership capabilities. The Government acts through its Contracting Officers and, by extension, its contract specialists. They are the “face to industry” with which the Government speaks and acts. They exhibit authority, execute responsibilities, create relationships and perform duties all as part of the Government’s side of the buyer-seller relationship. All of these abilities are accumulated on the job, integrated with appropriate levels of training and education. Many would argue that the “culturing” acquired through mentoring must be achieved by interaction with a Government workforce, while others would assert that capable and adept contractor personnel can greatly assist to the same degree. It can be rationalized that the existence of contractor personnel working as contract specialists in a Government organization can bring new dimensions to the performance of procurement duties. An important ingredient frequently missing in buying offices is the sensitivity and understanding of commercial and industrial procurement practices that work well, or do not function well, in the business world. Sound business methods and the decisions that result from genuine business thinking are vital to any “business” even if it is the business of Government procurement. The research has suggested, however, that most of the contractor staff employed to perform contracting functions are former Government acquisition personnel who have had little, if any, industry experience to bring to the procurement table. Some have even complained that the Government contracting knowledge they do bring is outdated and lacks currency. The business manager’s role required of contracting professionals today differs from the contracting technician’s role of even a few years ago. The research thus far has suggested that contractor employees performing procurement functions are dedicated, trustworthy and reliable. Their loyalty to the US is unquestioned. However, because their livelihood is derived from a private entity, there could be an inkling of suspicion on the part of Government managers that these employees might not always be placing the best interests of the Government ahead of all others. This thought could carry into the interactions between Government contract specialists and contractor personnel where proposed courses of action might not be the most beneficial to the Government. Ruling out ignorance or incompetence for the moment, some would question that contractor employees would investigate all viable alternatives before coming forth with a proposed solution, particularly if one or more alternatives were perceived as detrimental to their company.

### **Procurement Options**

One of the major concerns regarding procurement of contracting functions is the long-term affect this would have on the ability of agency management to develop and consider procurement options. Over 40% of the respondents believed that this will expand the procurement options while less than 25% believed it will limit such options. Almost 30% felt it would neither limit nor expand the procurement options. Most notably, Policy and Senior Management personnel mostly believed that it will enhance options. Arguments can be made for both the notion that options are expanded and the concern that options are limited. Several valid points support the former. Contractors can free up Government personnel to perform more complex or value added tasks; they can come with specific skills



and expertise to supplement Government weaknesses; they usually operate in a competitive environment and, therefore, have developed innovative approaches that can be shared with the Government; they are not as stove-piped in their thinking and training, and they come at a time when in-house resources and capabilities appear to be extremely low. One of the chief reasons set forth by proponents of the “expand” position is that contractor employees bring knowledge of industry best practices and business concepts that can be shared with contract specialists. This could be a way of introducing commercial procedures and actions, which might greatly assist in executing a more effective and efficient procurement system. Consider, however, the sources from which these contractor personnel might come. Many buying organizations claim that their contractors use former Government civil servants and military personnel, which increases their ability to perform contracting functions. But this almost assures that they will have had little industry experience. Even those individuals who have previously worked for companies holding prime contracts with the Federal Government have been in the Contracts Division and interfacing directly with their Federal counterparts. Not until you get to someone with experience in the Procurement or Subcontracts Department of a company will you find an individual likely to be immersed in business practices. If employees come from outside this realm, they probably have had little “Government” experience with which to execute their contracting responsibilities and will most likely have a significant learning curve in becoming familiar with the Federal procurement world. The prime reasons set forth by those who claim it will limit options involve: (1) a belief that a contractor’s objectivity will be questioned because they might not always have the Government’s best interests at heart; (2) the restrictive nature of firewalls and other safeguards necessary to ensure prevention of conflicts of interest; (3) a denial of valuable training and experience for junior Government personnel; (4) contractual limitations placed on organizations as to how they can use contractor employees; (5) experience with contractors where little assistance with options was provided; and (6) fewer experienced civil servants available to adequately assess and evaluate contractor performance. Those who felt there would be no affect on the ability to develop procurement options essentially believed that talented individuals will make a considerable contribution regardless of their origin: Government or contractor. Further, they point out, it really is up to management to decide how to act on specialists’ input, no matter what the source

### **Market Participation**

The extent to which companies are willing to participate in procurements when one or more other companies are involved in performing contracting functions for the Government should be of some concern. The health of the industrial base is often measured by the amount and nature of competition. If companies become suspicious of their treatment in Government competitions, their eagerness to continue may be dampened. The result could be that less information is forthcoming, particularly confidential and private data, or worse, that companies withdraw from Government competitions altogether. The “large” contractor dependent on Government contracts, particularly if it is a sole source, is less likely to disengage but could potentially restrict the flow of information. Companies with a significant amount of commercial business in addition to public contracts could very well decide to no longer stay connected with Government procurement. Over one-half of the respondents are concerned about a negative impact. Most of the respondents from the Services, over 75%, believed that a negative affect could occur, but no one from the Defense Agencies held this belief. Many of those from the Defense Agencies have had experience with contracted procurement services and can report their views from actual situations. The primary concern from those expressing a negative impact centers on the fairness and objective treatment of competing firms. The inappropriate use of proprietary



data, biased evaluations, and undue influence by private companies all can lead to distrust in the integrity of the contracting process. Some would point out that all of these abuses could occur with Government personnel as well but Federal laws impose civil and criminal sanctions on these individuals which is not the case with contractor employees. This affect is subtle and difficult to measure because it entails industry perceptions. It is unlikely that most companies, if questioned, would cite their distrust of the system as the reason for non-participation.

### **Integrity of the Contracting Process**

This area was brought out on both surveys. Although some of the respondents asserted that the best way to ensure integrity is to completely avoid using contractors, most provided thoughts and ideas they felt would help to maintain a robust contracting system. Many pointed to proactive efforts that will maintain necessary components of integrity. Sensible policies that discuss the legal, ethical, and practical aspects are critical. Integrity has to do with the image and reputation of the system. The actions, or inactions, resulting from “challenges” to the system, such as fraudulent or abusive events, shape the character and personality of the system. How the Government handles a breach of our laws and ethics policies, both by civil servants and contractors, is highly visible and reaches to the heart of our moral fiber. It is the responsibility of every member of the acquisition team to do his or her utmost to preserve the highest quality of our collective personality and culture. Certainly, safeguards and precautions are vital. Methods to discourage or prevent conflicts of interest, illegal actions, and other similar activities must be in place. Internal Government efforts, such as oversight, audits, reviews, surveillance, awareness training, and firewalls can and should be used. External efforts focused on contractors are also important and could include non-disclosure statements to protect sensitive data, financial disclosure, and ethical and integrity certifications. Going a step further, it could be argued that contractor employees who have been entrusted with the same responsibilities as civil servants should face the same consequences for contraventions of that trust. Civil and criminal sanctions should apply equally to all who are accountable for public endeavors. A very recent (March 2008) GAO report cited the need for additional conflict of interest safeguards for contractor employees who work alongside DOD civil servants.

### **Procurement Policy**

This topic was broached to the Policy and Senior Management personnel in both the surveys and interviews. Over 60% believe that a policy statement would be extremely helpful in clarifying top management’s position on all aspects of this issue. Their main concern is the range in difference of opinion concerning the definition of inherently governmental functions and a more direct application to contracting functions is needed. The 35% who do not believe a policy statement is necessary believed that sufficient policy and guidance already exists and any further language on the subject would probably serve to make things more restrictive. Key elements that should be included if such a policy were published varied. Respondents felt a policy should be very flexible and include some or all of the following: (1) identify those to whom the policy applies, (2) identify functions that are considered acceptable for contracting out, (3) cite safeguards to be used, (4) identify sanctions for failure to comply with the policy, (5) provide conflict of interest mitigation strategies, (6) establish approvals and approval levels, (7) emphasize that contractors have no decision authority, (8) specify that contractors cannot commit the Government, (9) suggest best practices in using contractors, (10) identify risks and how to manage them, (11) identify what contract types should be used, (12) require non-disclosure agreements and



financial disclosure statements, (13) suggest metrics to be used in evaluating contractor performance, (14) enumerate required contractor credentials or qualifications, and (15) outline the extent to which contractors can participate in Government events outside the workplace.

## Conclusions

**Contracting out of procurement functions has been effective, however, robust metrics to measure and assess contractor performance are lacking.** Almost all respondents stated that contracting out of procurement functions was effective, however, most utilized mission attainment and perceptions of overall contractor performance as metrics. These measures should not be discounted, as they are clearly important to the end user. However, they represent a fuzzy account of effectiveness without clear criteria. There were no comprehensive or universal metrics nor framework utilized for determining effectiveness across process, workforce, and outputs with regard to quantitative measures (objective) and qualitative measures (subjective). Any specific metrics cited were generally being utilized in an ad hoc and inconsistent manner. In light of capacity and capability shortfalls, the ability to utilize contractors to complete essential missions is considered a success. However, long-range assessment of effectiveness against established criteria is not occurring.

**The phrase “inherently governmental function” continues to be inconsistently interpreted and applied throughout DOD.** The blurred distinctions between inherently governmental and non-inherently governmental functions caused by the discretionary ability of agencies to decide its borders will continue to trouble the acquisition process until clarification has occurred. The Acquisition Advisory Panel has recommended that OFPP update the principles agencies use in determining which functions must be performed by Government employees. This study has served to confirm that such a recommendation is valid and pressing.

**Personal services relationships are almost inevitable in the close working circumstances required between Government contracting employees and contractor personnel performing procurement functions.** The lines between the buyer-seller relationship and the employer-employee relationship have become more distorted than ever. Contract award requires much higher-level review and interaction with the author of documents. These exchanges, if done between Government Contracting Officers and contractors could be interpreted as personal services. The co-location of contractor employees in Government facilities certainly creates the appearance that they are Government employees if not actual treatment as such. The contracting functions that might be contracted out are frequently so closely intertwined with functions that must be performed by Government personnel that a personal services relationship will almost certainly develop.

**The contracting community is seriously concerned about the potential for conflicts of interest, both organizational and personal, when contractors are used to perform contracting functions.** The issue of conflicts of interest has come up on numerous occasions during this research. Legal concerns almost always turn into a discussion of conflicts of interest and ethical considerations frequently result in the same scenario. Government employees have been so carefully trained over the last several years regarding not only inappropriate but also illegal behavior that they are very sensitive to not only actual situations but also the perception of conflicts. One step to lessen the potential



for conflicts of interest would be to establish firewalls within the organization that prevent contractor employees from operating outside the specific boundaries of their particular project. In reality, this becomes very expensive to structure and enforce. One drawback is that this does not allow contractor personnel to transfer knowledge and freely interact with Government contract specialists outside their firewall, which has been cited as a benefit to having contractors present in the first place. The Acquisition Advisory Panel believes that because the *FAR* provides considerable leeway to agencies in addressing actual or potential conflicts of interest and because there is a lack of guidance in mitigating such conflicts leading to inconsistent application of the regulations, uniform regulatory language is needed.

**Specific measures must be taken to ensure ethical standards are maintained and the integrity of the contracting process is protected.** One might assume that so much education has gone into shaping the ethical character and identity of the acquisition workforce in recent years, that this conclusion would be unnecessary. The Darleen Druyun affair caused considerable consternation within the acquisition workforce, particularly contracting community. This situation came up during interviews in the context of ethical principles and an imperative need to protect the integrity of the acquisition and contracting processes. It caused acquisition organizations to “pull back” and reexamine the fundamental structure of their ethical climate. Are the right checks and balances in place to prevent or discourage such events? Does the senior leadership put correct and suitable emphasis on ethical principles and moral values? Are instances of ethical and standards of conduct transgressions handled in a vigorous fashion? Are subtle indiscretions and instances of wrongdoing dealt with promptly and aptly? Have we assured industry, with overt measures, that such irresponsible actions will not be repeated? A majority of survey respondents deem that ethical issues are clearly associated with contracting for procurement services and that specific actions are necessary to protect the integrity of the contracting process.

**Contracting out of procurement services will have a negative affect on the ability of the Federal Government to develop Contracting Officers but may expand the ability of Government agencies to develop procurement options.** Over 65% of the respondents maintained the former. Contracting Officers grow from the experience of having worked as contract specialists. They need to grasp the underlying fundamentals, concepts and basics; understand the implications of particular courses of action; and experience various assignments that require critical thinking, interpretation of regulations and policies, judgment skills, cultural awareness and the ability to make trades. All of these skills and abilities are acquired on the job, interspersed with appropriate levels of training and education. As the decision is made to increase the number of contractors in the workforce, there will be fewer full time civil servants hired, which ultimately reduces the pool of potential Contracting Officers. If lower level functions are contracted out, they may be ill-prepared to do the more complex tasks later in their careers. Over 40% of the respondents felt procurement options would be expanded. They cited that contractors can bring new ideas to the discussion, they can interject industry business methods, they allow Government personnel to perform more difficult tasks, they can come with specific skills and expertise, and they may have innovative approaches which can be shared with the Government. Government procurement has long been reproached for its lack of understanding of commercial methods and sound business concepts and practices. Contractors may, for example, be able to accomplish and supply market research and planning alternatives that would be more difficult for Government personnel to provide.





**There is mixed opinion regarding the affect contracting out of procurement services would have on companies participating in the marketplace for Government contracts.** This research started with the premise that there could be a negative affect on the willingness of some companies to either compete for Government contracts or to be open with information, technology and data if contractors were performing Government contracting functions. If companies become suspicious of their treatment in Government competitions, their eagerness to continue may be dampened. Firms are more likely to question the integrity of the process if non-Government personnel handle proprietary information and participate in or influence acquisition strategies and source selections. Vendors could lose confidence in the fairness and objective treatment of offerors. Although a majority held this view, several respondents, with many years of experience in using contracted procurement services believed that there would not be a negative affect on market participation. In all of their dealings with industry, they have not seen any perceived or real impact on market participants. They felt that offerors are very willing to do business with the Government even though other companies are performing contracting functions.

**Government contracting functions are being performed by contractors because buying organizations lack sufficient human resources to accomplish mission requirements.** Time and again throughout the surveys and interviews, the chief response to a question about the need to use contractors was that the levels of Government personnel are too low to permit adequate performance of the workload. Contracting Officers and contract specialists are overwhelmed and feel they are working in sweat shops. In certain geographical areas, the same positions in other Federal agencies are far less demanding and provide the same level of compensation. Openings in these agencies are very attractive. It is literally impossible to fill vacant positions with qualified applicants. Downsizing actions taken in the acquisition workforce over the last several years, large numbers of retirements, hiring freezes, slowly developing intern programs and a cumbersome personnel recruitment system all have added to the problem. Although hiring authority has improved in very recent years, there is a significant gap between the entry level and the journeyman level employee. All of these conditions have caused some supervisors to solve their human capital dilemma by contracting out.

**A majority of senior contracting personnel believe that contracts for procurement services should be of a temporary nature.** Over 60% of senior contracting personnel believe it should be on a temporary basis and limited to surge or emergent demands while the Government recruits and trains organic resources. There is recognition that a periodic reevaluation of need and internal capability should be the deciding point to continue under contract. Although these contracts are viewed as “temporary,” if the long-term plan is to convert back to the Government any functions contracted out after sufficient staff has been recruited and hired, then the timeframes could be in years. If the contracts are for certain functions, such as market research or requirements development, in which the contractor is typically engaged in a specific acquisition under a task order, then these are of a more temporary nature. There is not a unanimous opinion that they be temporary. Some felt they were recognizing reality by pointing out the long-term problem of getting additional Government billets, and that contracts should be placed on a permanent basis until and unless a cadre of trained Government 1102s is in place, which will take years. Contract closeout is an example of a recurring need in which organizations may never be caught up and contracted services are, out of necessity, integrated into the normal workload.





**Contractor personnel performing procurement functions should be co-located with Government contracting personnel.** There is a need for close communications on a face-to-face basis between all members of the acquisition team. Contractor personnel must be an active part of the Government team, building solid working relationships and learning from each other. Physically separating Government and contractor employees hampers communication and would not create a very conducive work environment or atmosphere and might tend to develop an “us” versus “them” mentality. With multi-functional Government teams, it could be detrimental to segregate out the contractor employees. Services involve personal interaction and relationships. Physical separation simply artificially complicates performance of a cohesive objective. The interface that occurs through physical proximity outweighs most risks that might surface. Professional interaction and synergy are needed to efficiently perform the functions. There is a need to be close to the customer for effective support and to reap the efficiencies of real-time decision-making. Also, co-location will aid in the performance of the Government’s responsibility for contractor oversight. Examples exist in which contractor employees were physically separated but were relocated to the Government facility because the ability of Government personnel to interact with contractors was very difficult. It is true that there is the potential for direction by the Government leading to personal services, and physical separation would assist in the perception that the services are not personal. Additionally, access to sensitive and proprietary data, security considerations, and the potential for conflicts of interest is of real concern. Safeguards and security measures must be taken to protect against such occurrences.

**The percentage of the contracting workforce and/or the percentage of the contracting workload placed on contract for performance by contractor employees should not exceed an established maximum.** This study evaluated a limitation in terms of workforce and workload. The surveys indicate that most individuals advocate a maximum somewhere between 25% and 50% of either measure of effort. Although full time equivalents are easy to measure and a percentage of an activity’s end strength is easy to calculate, it is the view of this research that the percentage limitation be applied to workload as opposed to workforce. Individual contracting members of a buying organization perform a range of tasks and duties. Cutting them out of the organization slices through these tasks without regard to the complexity or nature of the tasks involved. Further, when focusing on workload, an activity can group various tasks that are candidates for performance by contractors, such as contract closeout duties, and apply the percentage to the grouped tasks. Government contract specialists do not perform just one set of duties, such as contract closeout, but are typically engaged in a fuller range of responsibilities. Workload considerations also permits the organization to think in terms of grouped tasks that can easily be described in statements of work, are fairly homogeneous, may be of low risk, and might be easily severable and require far less interaction with Government personnel, thereby potentially even allowing performance at the contractor’s facility.

**Requirements similar to those found in the Defense Acquisition Workforce Improvement Act (DAWIA) could be imposed on contractor employees performing Government procurement functions without difficulty.** Sixty-five percent of the senior contracts leadership believed that DAWIA or DAWIA-like certification requirements should be imposed on contractor personnel performing contracting functions for the Government. There is a feeling that these requirements are critical elements in the performance of complex functions and that contractors should be required to have the same level of competence as Government personnel. Contracting tasks have become more complicated, of a high-risk nature, and demand intellectually capable personnel who can reason through



the issues with common sense and wisdom. Many of the contractor personnel working in Government offices are former civil servants or military who achieved DAWIA certification while in the Government. They most likely already hold the requisite credentials. If serious thought is given to requiring DAWIA, the extent to which standards already exist that are comparable to DAWIA-type requirements should be explored. Professional association certification programs, industry association and corporate training programs, and academic certificate programs are all examples of existing or potential methods for alternatively meeting DAWIA-type standards.

**There is general opposition among Navy and Marine Corps contracts leaders to the notion of contracting out procurement functions.** Through interviews and from the surveys, it has become apparent that most of the Navy and Marine Corps contracting leadership are generally opposed to contracting out procurement functions. Although they will acknowledge that some contracting functions, such as contract closeout, are being effectively performed by contractors and might not otherwise be accomplished in a timely fashion, the vast majority of tasks are, in their estimation, so closely intertwined with inherently governmental functions that they must be performed by Government civil servants. Even in those cases in which a buying organization is utilizing contractors fairly extensively, there is a feeling that if sufficient qualified personnel were available they would rather accomplish all mission requirements with Government employees.

**A policy regarding the contracting out of procurement functions is needed.** Sixty percent of the senior leadership believed a policy is needed to set the general boundaries for contracting out and would be extremely helpful in clarifying top management's position on all aspects of this issue. Their main concern is that there is too much difference of opinion concerning the definition of inherently governmental functions and a more direct application to contracting functions is needed. This is coupled with the perceived need for an identification of conflict of interest mitigation strategies, metrics to be used in evaluating contractor performance, appropriate sanctions for contractor transgressions, the qualifications and credentials that should be required of contractors, the hidden risks involved, and best practices in using contractors, to name just a few.

## Recommendations

**Metrics should be developed and robustly utilized to monitor and assess contractor performance of Government contracting functions.** This research has found that the acquisition workforce believes that the procurement of contracting functions have been relatively effective based on only two primary factors: (1) was the mission accomplished in that the contracting functions were performed, and (2) did the contractor perform well enough to be considered for future contracts. As was discussed earlier, there are obvious shortfalls in the existing means to determine effectiveness, in that it lacks clearly defined criteria and the degree to which the value of effectiveness is determined. To aid in the development of valid metrics to determine effectiveness, it is recommended that organizations use the model depicted in Appendix 1. This study suggests specifics that could be used as a starting point for creation of organization-unique metrics and measures for local application that can be inserted into the appropriate sections of the model. Data requirements should be tailored within the model framework for each unique application and should strike a proper balance to ensure that they can elicit contractor performance consistent with strategic organizational performance goals. Activities should utilize this model framework as the basis of construct for any contracting action for procurement



functions. Higher level management and policy personnel can use this model to gather and disseminate informational and actionable metrics within their organizations. The value of this model is that it brings together the quantitative (objective) and qualitative (subjective) dimension together with the three types of metric categories (process, workforce, and outputs) and overlays these on the six phases of the contracting process. The contractor's work effort must be evaluated and assessed. Government contracting personnel will have the principal responsibility for performing these evaluations. In actuality, assessing the performance of a contractor performing Government contracting functions is not unlike the assessment that must occur when Government managers and supervisors are evaluating their own civil servant workforce. Many of these judgments are highly subjective in nature but nonetheless must be performed. It is suggested that this model will assist in that difficult task.

**The Department of Defense should issue a policy regarding the contracting out of procurement functions.** There is overwhelming evidence, as brought out in surveys and interviews, that some type of policy should be disseminated from the Office of the Secretary of Defense that will guide the Services and Defense Agencies through the challenges created by utilizing contractors to perform Government contracting functions. This is not to say that organizations have not already successfully carried out the responsibility of awarding and administering contracts under which contractors are effectively and productively executing these duties. At a minimum, the policy should address the areas brought out earlier in this paper. Such a policy will go a long way in helping to clarify many of the issues currently plaguing DOD acquisition organizations.

**Safeguards to protect the integrity of the contracting process when using contractor support to accomplish contracting functions should be strengthened and rigorously enforced.** Utilization of contractor employees to perform Government contracting functions is relatively new and has posed a new set of complex challenges. This research has confirmed the existence of serious challenges to the procurement process that have already been known on a fairly widespread basis. Not the least of these is conflicts of interest, both organizational and personal. Other challenges that may increase as more and more contractors become involved in performing contracting actions are ethical problems, personal services issues, legal issues, and general overall threats to the integrity of the contracting process. Several measures are already in place to protect the Government from improper and unethical behavior on the part of both civil servants and contractors. In many cases, however, experience has shown that these have not been enforced with the thoroughness and as meticulously as they should be imposed. Contracting personnel interviewed and surveyed for this research have repeatedly pointed to the potential for biased and less-than-objective action on the part of contractor employees whose loyalties and motivations may, from time to time, be at odds with the best interests of the Government. The public image and reputation of the procurement process is vital. The "fishbowl" environment within which this process takes place sets an even greater responsibility for preserving an untarnished image on all members of the acquisition workforce.

**The prohibition on the use of personal services contracts should be removed.** Throughout this study, references to the difficulties encountered by Government organizations attempting to avoid personal services situations have continually arisen. Although a contract may have been carefully crafted to eliminate any potential for such a relationship, including a precisely defined statement of work, actual contract execution may be riddled with instances where the line has been crossed. Some organizations have taken



extreme measures, at some expense, to structure working relationships that meticulously avert any opportunity for personal services. Other organizations have essentially ignored the rules because they are too unrealistic and unworkable. It has been demonstrated in this study that the close working relationship so important to effective execution of contracting duties requires a significant amount of interaction and direction that is of a personal services nature. This recommendation is consistent with a recommendation by the Acquisition Advisory Panel, which called for removal of the restriction regarding supervision of contractor employees by Government personnel. All of the other aspects of the employer-employee relationship, such as hiring, firing, performance appraisal, compensation, promotion, etc., remain exclusively within the contractor's area of responsibility.

**Civil and criminal penalties currently applicable to Federal employees should be extended to contractor employees who are performing contracting functions for the Government.** It has been noted in this study that contractor personnel performing procurement functions on behalf of the Government are not subject to the same penalties and consequences that would be enforced upon civil servants for violations of statutes, standards of conflict and ethical principles. The Government is potentially at significant risk for unlawful or dishonest actions taken by contractor employees acting on its behalf. Contractor employees are not liable for the work they perform or the recommendations they make. Sanctions do exist for illegal or improper contractor behavior, such as suspension or debarment, but this generally fails to recognize employee misbehavior. Companies that may have been injured by the unauthorized and prohibited actions of a contractor employee performing contracting actions may have recourse against the Government to obtain a remedy for an offense, but the Government, in turn, does not currently have recourse against that employee except to complain to the contractor and seek removal. It has been expressed by many that contractor personnel performing Government contracting actions should be held to the same standards and consequences for wrongdoing as civil servants. This could occur by extending appropriate civil and criminal penalties to those contractor individuals performing contracting functions.

**A hierarchy of contracting functions should be developed as a classification of tasks that can be used to support various decisions and reporting requirements.** Appendix 2 presents a proposed "Hierarchy of Contracting Functions" as a conceptual method of arraying and evaluating contracting tasks or functions that are typically performed by Government buying organizations. The hierarchy can be uniquely tailored to each organization to reflect their specific duties at the micro level. The hierarchy can also be used by DOD and the Services/Defense Agencies as a macro-level approach to categorizing and distinguishing tasks and duties by specific characteristics. This taxonomical approach to classifying functions permits organizations to identify characteristics that differentiate functions from one another. Once an organization has defined the objectives of its classification, e.g., candidates for contracting out, individual tasks can be placed in the hierarchy according to the interpretation it has made about each task. Explicit justification for the category of placement should be maintained. The hierarchy can then be used by an organization as an inventory of functions for a variety of purposes. One such purpose would be to support submission of function designations under the *FAIR Act*. The hierarchy could also be used by organizations as a common framework to compare the classification of tasks and supporting rationale with each other. Additionally, capability gaps in skill levels identified by the DOD Competency Model could be overlaid on this hierarchical model to determine where a particular function under examination resides in the overall classification scheme.



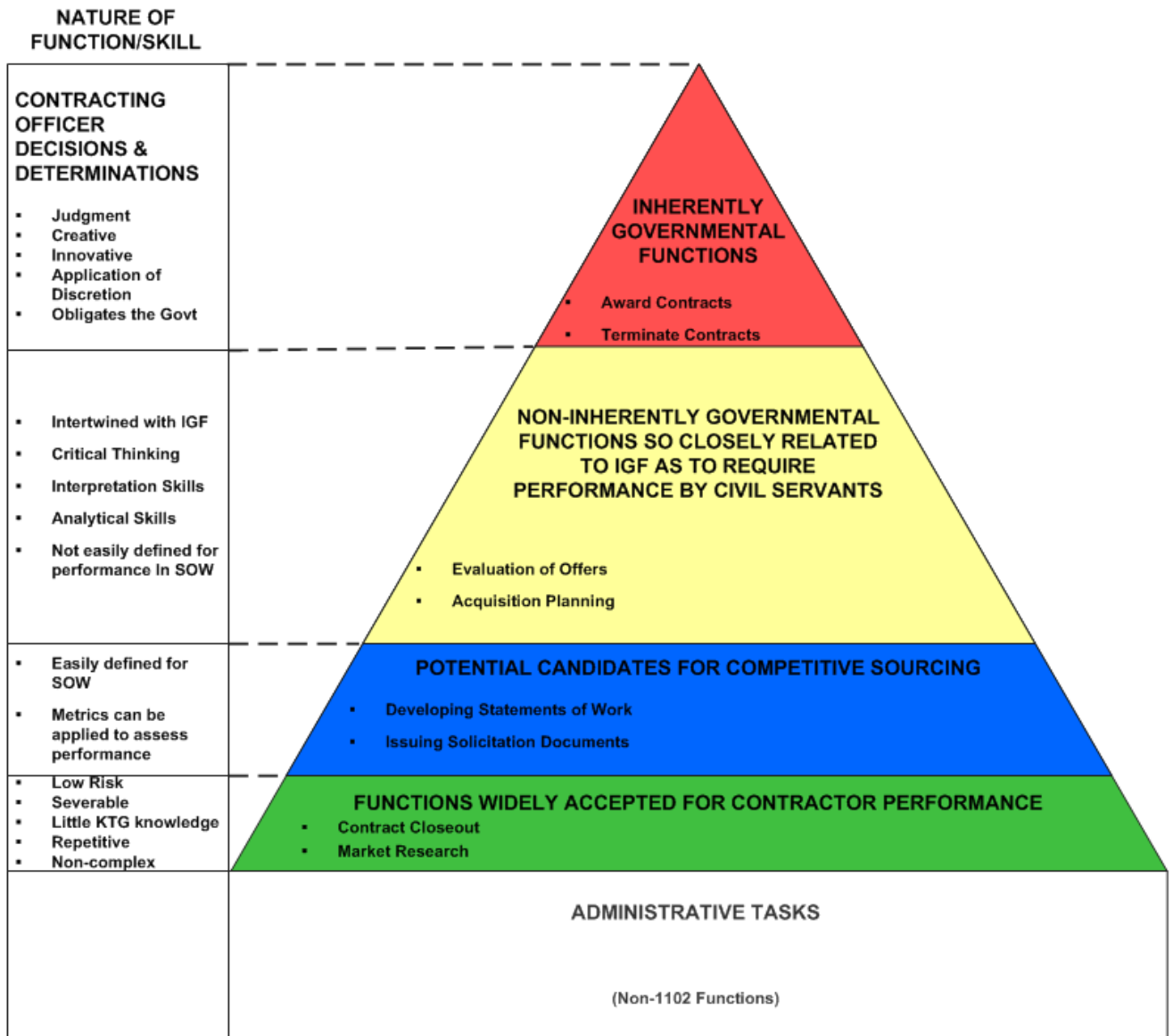
## List of References

- Acquisition Advisory Panel (AAP). (2007, January). *Report to the Office of Federal Procurement Policy and the US Congress*. Washington, DC: US Government Printing Office.
- Federal Acquisition Regulation (FAR)*. (2005). Washington, DC: US Government Printing Office.
- GAO. (1991, November). *Government contractors: Are service contractors performing inherently governmental functions?* (Report GGD 92-11). Washington, DC: US Government Printing Office.
- GAO. (2008, March). *Defense contracting: Army case study delineates concerns with use of contractors as contract specialists*. (GAO-08-360). Washington, DC: US Government Printing Office.
- Harry, B., Williams, J.S., Gilbreth A., & Kankey, R. (2005, November). *Contracting out procurement functions: An analysis*, Defense Acquisition University (DAU) (Research Report 06-001). Fort Belvoir, VA: Defense Acquisition University. Press.

## Appendix 1. Metric Analytical Model

Phase	ACQ Planning	Solicitation	Evaluation	Negotiation	Award	MGT & Admin
Application						
Process						
Workforce						
Outputs						

## Appendix 2. Hierarchy of Contracting Functions





# The Evolving Private Military Sector: A Survey

---

**Presenter: Dr. Nick Dew** is an assistant professor in the Graduate School of Business and Public Policy at the Naval Postgraduate School, Monterey, CA. Nick has a Ph.D. in management from the University of Virginia, and an MBA from the Darden Business School, as well as a BA in history from the University of York in the U.K.

Before joining academia, Nick worked in strategic management and sales & marketing for British Petroleum, Europe's largest company, including a two year assignment in BP headquarters and a three-year international assignment in Southeast Asia.

Nick joined the faculty at the Naval Postgraduate School in 2003 where he teaches strategic management in the MBA program. He researches the evolution of the RFID (radio frequency identification) industry and entrepreneurial decision making. His work has appeared in the *Journal of Evolutionary Economics*, the *Journal of Business Venturing*, the *International Journal of Entrepreneurship and Innovation* and the *Scandinavian Journal of Management*. For more information on entrepreneurial decision making, go to [www.effectuation.org](http://www.effectuation.org).

Nick Dew  
Assistant Professor  
Graduate School of Business and Public Policy  
Naval Postgraduate School  
Monterey, CA 93943-5197  
Tel: (831) 656-3622  
E-mail: [ndew@nps.edu](mailto:ndew@nps.edu)

**Author: Lt. Col. Brian Hudgens, USAF**  
Lecturer  
Graduate School of Business and Public Policy  
Naval Postgraduate School  
Monterey, CA 93943-5197  
Tel: (831) 656-2039  
E-mail: [bjhudgen@nps.edu](mailto:bjhudgen@nps.edu)

## 1. Introduction

“Because they remain uncategorized by any formal measure, the exact number of PMFs [private military firms] that have entered the market is difficult to establish and it most definitely remains in constant flux. The global number is estimated to be in the mid-hundreds.” (Singer, 2003, p. 79)

The purpose of this research is to help the US Department of Defense and other government security communities better understand the evolving PM (private military) sector (Avant, 2005; Jager & Kummel, 2007; Singer, 2003). We anticipate our readers will be government agents, members of the international community, or others who wish to make informed decisions regarding the use of PMFs. This report discusses a beginning step in establishing a long-term program of research on the PM sector at NPS. It is expected that knowledge about the sector will be built incrementally through a series of individual studies; no one study will provide a complete picture of the relevant features of the sector. However, we believe a good starting point is to develop quantitative data about the industry, which this report attempts to do. We suggest three reasons why this is an appropriate place to begin.

First, while there are several conceptual and qualitative publications on the sector, there are very few quantitative studies. Therefore, there is an important gap in our knowledge that we propose to fill with rigorous quantitative data.

Second, without even rudimentary quantitative data, we have no way of knowing whether the firms that have been studied as individual cases (such as MPRI and Executive Outcomes) or those firms that have been given significant media attention (such as



Blackwater and Halliburton) are typical industry participants or outliers. Thus, our starting point is to ensure that we have a reasonably accurate picture of the sector by compiling quantitative data on it. We need rudimentary data about the industry's size in aggregate (i.e., the demography of firms—cf. Singer's quote above), which major public corporations (such as the prime US defense contractors) are active in the sector and in what capacity, and the major capabilities of firms. Much of the data presented in this report fulfills these needs. The data is basic, but since our collective understanding of the sector is also fairly basic, this information may well be of some utility to readers of this report. As well as giving us a sense of what we think we already know, the data also provides a platform on which further studies can be built; i.e., it provides a context in which future research can be set. To proceed to these more advanced topics, we must first pass through the entry gate; that is, we must ensure that the basic building blocks for comprehension and analysis are in place. We think that at least some of the data we exhibit is new and has—as far as we know—never been presented before.

Third—and perhaps most importantly—while most of our data lends support to already-published literature, the process of studying a large data set and attempting to analyze it has brought to light certain discrepancies, inconsistencies and anomalies between the way the sector is sometimes described and the reality of the empirical data. This has led us to attempt our own re-description of the sector in a way we believe is more congenial to the data we have collected.

## 2. Methodology Used and Background to this Study

The data used in this report was collected primarily by three NPS MBA students (Jared Mitchell, Don Robbins and Chuck Dunar) working on their thesis project in the fall of 2007 under the supervision of Nick Dew and Bryan Hudgens. The combined faculty and student input into the data collection effort approximates one man-year of work.

Data collection proceeded through three phases. We started by assembling a list of firms known to be active, or to have been active at one time, in the PM sector. We screened various publications about the industry for an initial list of PMFs (for example, Avant, 2005; Singer, 2003). Based on this initial list of names, we assembled further names of firms using a snowball method (Goodman, 1961); i.e., our searches for information on the initial names invariably turned up new firms, which we then added to the list. We kept working on the snowball until we exhausted the search for new names; i.e., further searches did not reveal any new firms. Almost all of this searching was conducted online, using various databases available through the NPS library and public resources available via online search engines. Using this methodology, we assembled a list of 550 firms “named” by one source or another as having been active in the sector.

Second, we found that many firms in the sector have a website which offers information about the organization. Using these and other resources, we assembled more detailed data on the firms in our sample—such as their founding date, founder background information, country of origin, and data on the capabilities these firms purport to have.

Third, one of us conducted follow-up and fill-in data gathering on specific firms as part of the writing of this report.



Further elements leading to the assembly of this report included coding data in our database, analyzing the raw and coded data, and presenting it in easily understood formats. Coding (for instance) of capabilities was conducted by two of us (one student, one author). This process was particularly lengthy and laborious, since it involved over 2,500 lines of data on capabilities, many redundant descriptions of capabilities, and much recoding work in order to get the data into a “clean” format. Individual fields were coded independently, and critical variables (such as codings of Singer’s “Tip of the Spear” schema and Avant’s categorization scheme for contract types) were coded by both coders. Though we have not yet measured inter-rater reliability of these codings, we estimate that more than 80% of codings are identical.

The analysis process involved several iterations in order to produce the final charts, graphs and data presented in this report. The final portion of the research process involved both finding ways to display the data in formats that are easy for the reader to understand and writing this report.

The limitations of this study are worth particular attention. For most data categories, the data on PMFs is incomplete. For instance, we managed to find data on the founding dates of approximately 230 firms (approximately 40% of our sample). We obtained data (at least in some rudimentary form) on capabilities for approximately 70% of firms, but the quality of this data (measured in terms of its comprehensiveness and trustworthiness) varies considerably. The bottom line of our data-collection effort is that we can only analyze the data available, doing our best to verify its reasonableness as we go. We cannot attest for the accuracy of some aspects of this data—for example, that the capabilities firms purport to have are “true.” Of course, the accuracy of self-reported data is a problem for researchers generally, and not for our study alone.

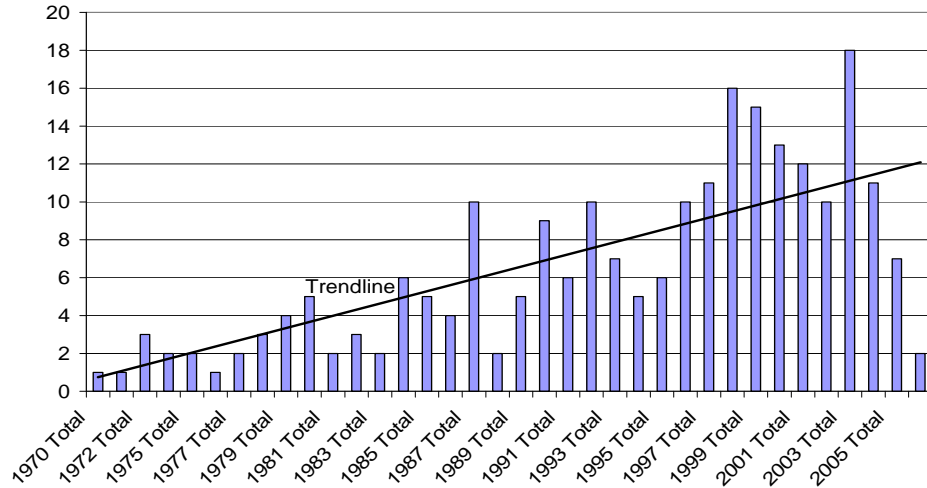
However, we do not know of any database on the industry that is more comprehensive than the one we have assembled. As far as we know, the sample size we have used is much larger than any other so far studied in the sector, and this should make our results more robust because of the (generally) favorable statistical properties of large samples.

### 3. Organizational Demographics of the PM Sector

#### **Founding Dates, Population and Industry Growth**

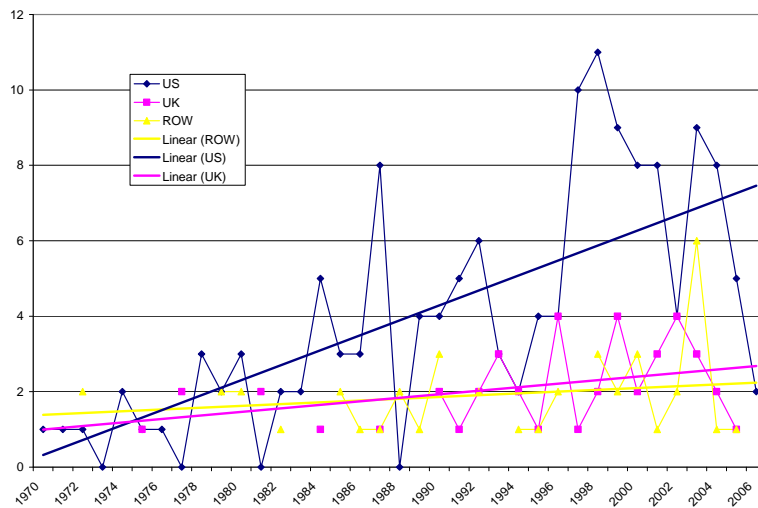
For this study, we traced data on 550 firms that appear to have been active in the PM sector. Of these, we were able to find data on the founding dates of approximately 230 firms. Based on this sample of 230 firms, the following pattern of industry entry emerges:





**Figure 1. Pattern of PMF Founding by Year 1970-2006**

Further examination of the data indicates that half the firms for which we managed to find founding dates were founded between 1995 and 2007; the other half were founded before 1995. This makes the PM sector a relatively young industry: half the industry is less than 13 years old; thus, the median age of firms is quite low. This fact is an interesting contrast to the history of mercenary companies, which, of course, has very deep roots—stretching back at least until the Early Modern period (15<sup>th</sup> and 16<sup>th</sup> Centuries) (Ortiz, 2007a).



**Figure 2. PMF Founding Pattern by Region**

Figure 2 suggests that the recent wave of entry of PMFs is predominantly a US effect. Note in particular the trend lines for firm foundings: the US trend line is rather steep, whereas the UK and ROW (rest of world) trend lines are almost flat. What this trend

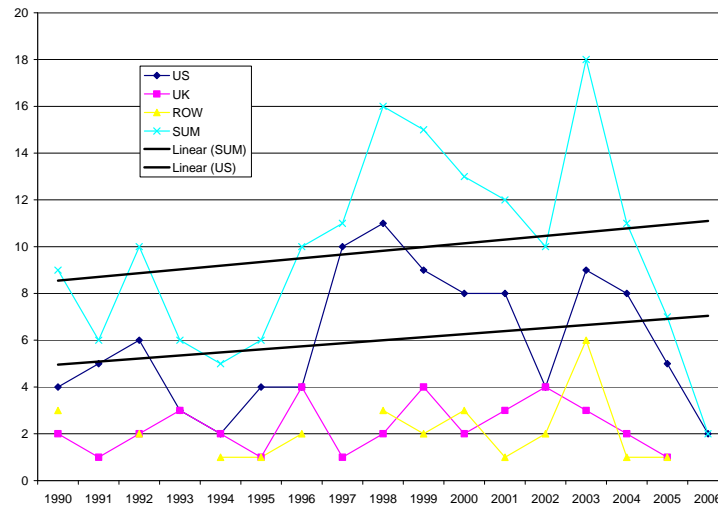
suggests is that PMF growth is being driven by US effects—such as outsourcing strategy in the late 1990s and the invasion of Iraq in 2003.

One possible way of thinking about entry into the PM sector is to categorize it as occurring in different “eras.” Table 1 indicates data on the average number of firms founded in three different eras.

**Table 1. Summary of PMF Foundings in Three Different “Eras”**

	SUM	YEARS	AVG
PRE-1970	35	25	1
1970-1989	64	20	3
1990-2001	120	12	10
2002-2006	48	5	10

If we examine this data graphically, we observe a different picture of the trends in PMF founding (note the trend lines are generally quite flat in Figure 3). Here, we can see that the surge in PMFs is a consistent feature of the post-Cold War era that is driven by new US firms entering the sector. This means that the sector growth is not a post-9/11 phenomenon (as is commonly thought), but a post-Cold War phenomenon.

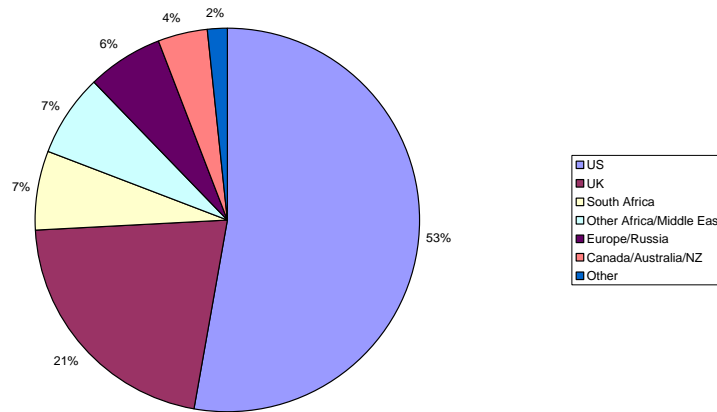


**Figure 3. PMF Foundings 1990-2006**

### Geographic Distribution of PMFs

We found it comparatively simple to retrieve data on the nationality of PMFs. We found data for over 500 firms (90%) of our population. Note that our data is very consistent with the IPOA’s (International Peace Operations Association) surveys (2006 and 2007) that were based on much smaller samples.





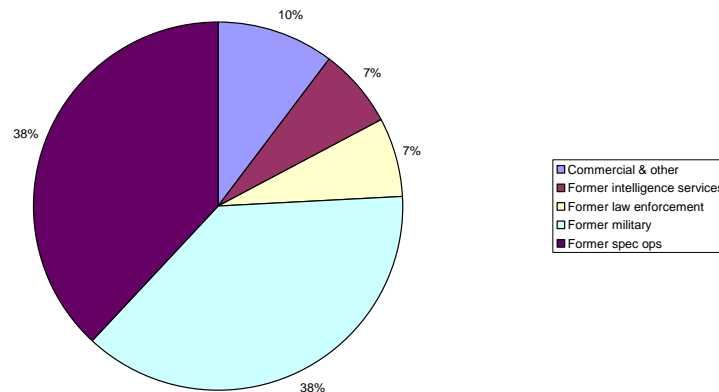
**Figure 4. Geographical Distribution of PMFs**

As is evidenced in the chart, the industry is a 50% US phenomenon and 20% UK. However, this was probably not always so. The tremendous growth in the number of US firms entering the industry in the past 10 years (see Figure 2) has probably changed the international composition of the industry. Prior to the burst of US entry, the industry was probably more cosmopolitan in its composition.

Several factors might explain this international distribution. One factor might be outsourcing and privatization, which may make PMFs more prevalent in the US and UK. Another factor may be demand factors—i.e., provision of surge capacity for the US and UK to meet their commitments in Iraq, Afghanistan and to the War on Terror. A further factor may come from the supply side—i.e., a distinct geographical pattern governing the distribution of skills required for establishing PMFs. This requires the *combination* of specialist military/security skills and generalist entrepreneurial skills. These may be more prevalent in the US and UK. Lastly, we have not yet tested this distribution for correlation with more general factors, such as defense spending in these particular geographies (PMFs per \$BN defense spend), population (PMFs per million), or economic scale (PMFs per \$BN GDP). Future research might endeavor to explore these and other possible relationships.



## Founder Background for PMFs



**Figure 5. PMF Founder Backgrounds**  
(based on Data on 116 firms)

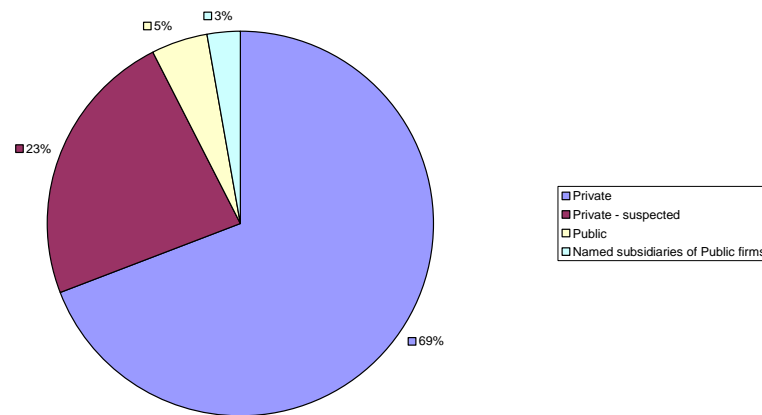
Figure 5 presents the data we managed to collect on founder characteristics for 116 PMFs (approximately 20% of our sample). What this reveals is initially unsurprising: most PMFs are founded by individual entrepreneurs or entrepreneurial teams that have prior military experience. However, the proportion of firms founded by individuals with special operations experience is a surprise: almost 40% of firms were founded by individuals with this background.

One possible explanation for this result is that our sample is skewed: perhaps firms founded by individuals with special operations experience are more likely to “tout” their qualifications. Other possibilities include both demand-side and supply-side factors. On the demand side, perhaps special operations skill sets are in particularly high demand in the PM sector, or these activities are seen as particularly good or easy targets for contracting-out.

On the supply side, one again wonders about the combination of skills required for running a successful PMF: perhaps individuals with entrepreneurial tendencies are more likely to select into special operations domains, or perhaps special operations experience tends to nurture particular organizational skills and self-confidence that lead individuals to participate in an entrepreneurial endeavor.

Based on our initial analysis, founder characteristics would make a good topic for future research on the PM sector.

## Private/Public Split



**Figure 6. Public-private: PMF Status**

Data we gathered indicates that well over 90% of the firms in the PM sector are privately held. Only a few firms (25) active in the sector are publicly held. This number is based on a generous definition of the industry and, therefore, includes the major defense contractors (the “primes”) and many firms that mainly supply IS/IT-related products and services to the DoD and other security agencies worldwide. The number of “pure play” public PMFs is, in fact, very low: only two firms in our sample meet this definition (DynCorp and ArmourGroup).

One important issue inherent in this analysis is the lack of transparency in the industry; this flaw is frequently highlighted by critics. PM-sector firms are perceived to be rather secretive (Avant, 2005). Our data points to the fact that there are two elements involved in this secrecy:

- First, private firms generally lack transparency to outsiders, regardless of their industry. Some of this is a systematic side-effect of being private, not the result of deliberate policy. After all, they are not required to be transparent, and they have no reason to be. If most PMFs are private, then one would expect the industry to lack transparency regardless of its activity type.
- Second, PMFs have other legitimacy-related concerns and sometimes security-related reasons for shying away from the public eye. Thus, their privacy, opaqueness, ambiguity and general lack of transparency may be a deliberate strategy. This element is over-and-above what is common to all private firms.

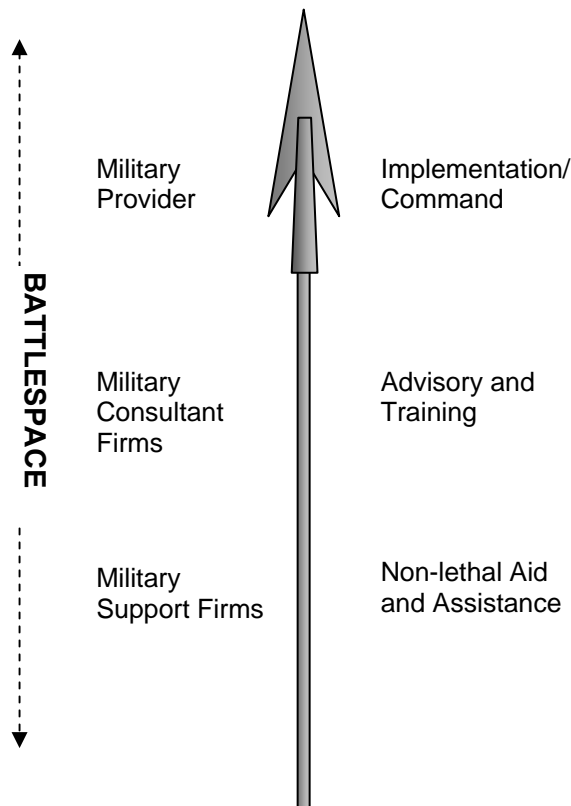
A second concern brought to light by our data is that—despite some claims to the contrary (for instance, Valero, 2008)—it seems rather unlikely that the PM sector will ever emerge as a significant aspect of the so-called military-industrial complex. The sector’s organization is quite dissimilar from that of equipment manufacturers; unlike the manufacturing sector, the PM sector simply has not the economies of scale that have driven a concentration of large players (the “primes”). Instead, the industry is highly dispersed—i.e., populated by firms that are generally quite small compared to the defense-equipment sector.

#### 4. Capabilities/Activities Analysis

Our database contains 2,500 lines of data on the capabilities/activities of 395 PMFs. The comprehensiveness of this data varies by firm; but as a starting point, we believe it is a useful approximation of what firms in the sector do. To help analyze the data, we began with the categorizations provided in the literature on the PM sector, i.e., Singer (2003) and Avant (2005).

##### **A Starting Point: Singer’s Categorization of PMFs**

One popular device that emerged from Singer’s (2003) book on the PM sector is the “tip of the spear” analysis. Singer used this tool to help explain the industry and then used case studies of particular firms in different places on the spear to illustrate the analysis in more depth. For instance, he posed EO (Executive Outcomes) as the quintessential “Military Provider Firm,” MPRi as an example in the “Military Consultant Firm” category, and KBR as an example of a “Military Support Firm.” See the figure below for a reproduction of Singer’s diagram:

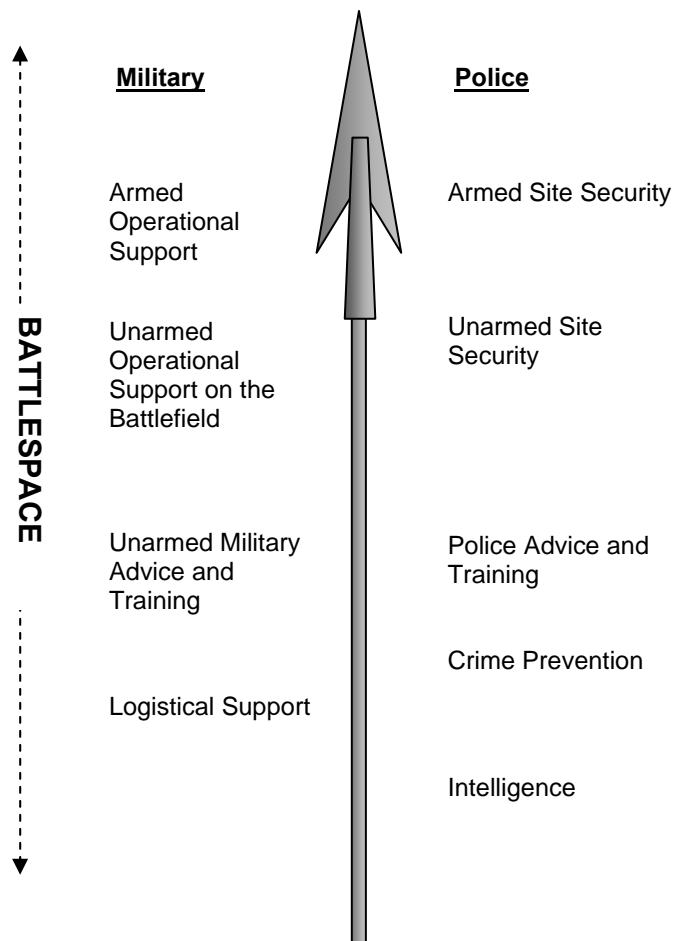


**Figure 7. Singer’s “Tip of the Spear”**

(Singer, 2003, p. 93)

## Avant's Refinements to Singer's Categorization Scheme: Form Firms to Contracts

Deborah Avant (2005) proposed a slightly different approach to the analysis Singer provided. She found that it was difficult to classify individual firms using Singer's typology because many firms are diversified, offering a variety of services that appear in different places on the spear (e.g., Blackwater does close protection, firearms training, has a parachuting training team and produces an armored vehicle, among its activities). Moreover, Avant found that firms move around the spear, offering different services to different buyers at different points in time. For these reasons, Avant proposed that *contracts* are a better tool for analyzing the sector. She categorized contracts according to five types, as follows:



**Figure 8. Avant's Analysis of the Spear**

(Avant, 2005, p. 17)

## A Further Revised “Tip of the Spear” Analysis: From Firms, to Contracts, to Capabilities

Singer’s analysis focused on firms; Avant’s analysis focused on contracts. In what follows, we offer an extension of these analyses that focuses on capabilities. This analysis is premised on the observation that firms are not only diversified and move around the spear, but that an analysis of what tasks firms *have been* performing over time does not capture firms’ *potential* movement around the spear. There is an even broader scope of latent activity. One way to investigate this latent potential is to collect data on the capabilities firms claim they have. The following section focuses on these capability sets.

Capabilities are critical because underlying contracts (transactions in the marketplace) are firm-level capabilities. The concept of capabilities is widely used for analysis in the strategic management literature because it focuses on the building blocks for activities that are present in a firm (and, therefore, an industry sector). Firms distinguish themselves by their capabilities—firms are able to get contracts others cannot access because they can either do things other firms cannot or can do them at a lower cost than their competitors can. Therefore, in strategic management, capabilities are often thought of as crucial underlying variables that explain the relative performance of firms (Barney, 1991; Teece, Pisano & Shuen, 1997).

*Based on our attempts to cluster the approximately 2,500 individual capabilities in our data set, a rather different image of the “tip of the spear” emerged. By our analysis, the spear is much more heterogeneous than either Singer or Avant’s analysis suggests. The key result of our analysis of individual capabilities is that the PM sector is by no means unitary. In fact, it is made up of quite different sub-sectors, which are probably better thought of as a patchwork quilt than as elements up and down the spear. This is particularly true for the category “Military support firms,” which contains a smorgasbord of sub-sectors. These sub-sectors are essentially unrelated to one another in terms of the underlying capabilities they require to support contracts in any particular area. This means that the firms competing for contracts in these sub-sectors tend to come from very different industries (for instance, some services are “add-ons” provided by major defense contractors, while other services are provided by firms with capabilities that are largely undifferentiated from civilian/commercial skill sets, such as logistics or many IS/IT security activities). This led us to present a revised “tip of the spear” diagram, displayed in Figure 9 below (in the figure, the individual elements are not sized or ordered to represent the data, but merely to convey an overall image of the sector).*



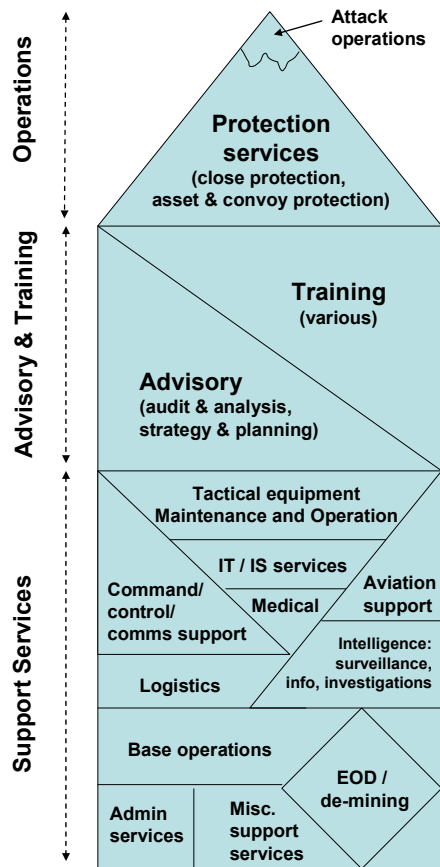
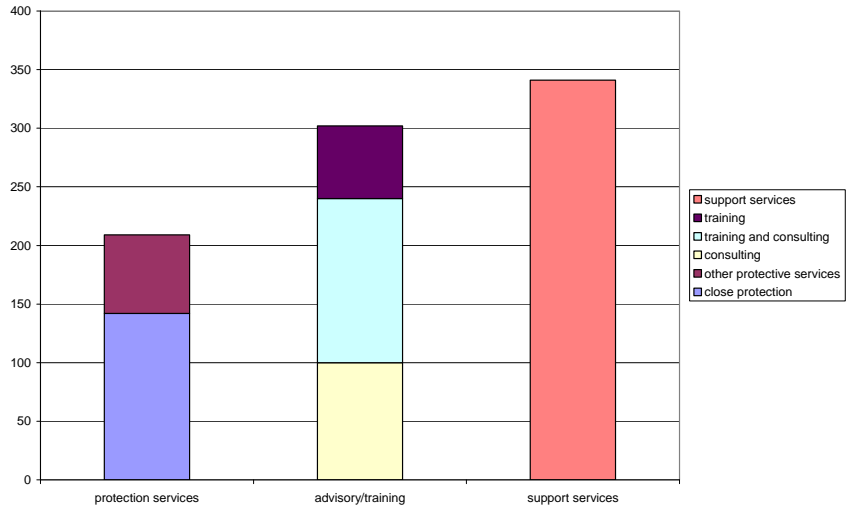


Figure 9. Revised "Tip of the Spear"

#### D. Capability Analysis

Our data suggests that approximately half of the firms in our sample of 395 are engaged in some kind of protective and security services; 75% do advisory and training work, and almost 90% are engaged in some kind of support services (variously defined). This data points clearly to the intermingling of service provisions up and down the spear that Avant and Singer (and others) have remarked on as a characteristic of the sector.





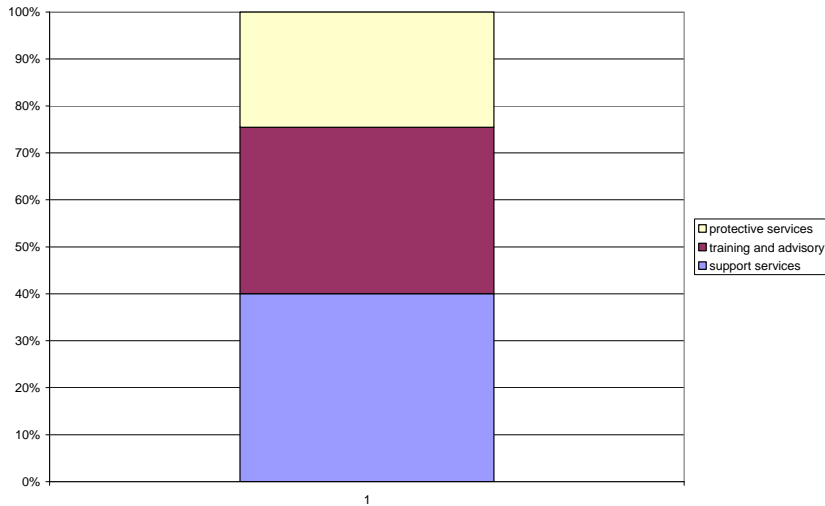
**Figure 10. PMF Activity Summary**  
(number of active firms)

For the exact percentages, see the table below:

**Table 2. Proportions of PMFs Active in PM Sub-sectors**

	% of Firms Active (Sample 396)
Protection Services	53%
Advisory/Training	76%
Support Services	86%

Another way to display this data is as proportions of the spear—i.e., to examine the number of firms active in different sub-sectors of the PM sector:



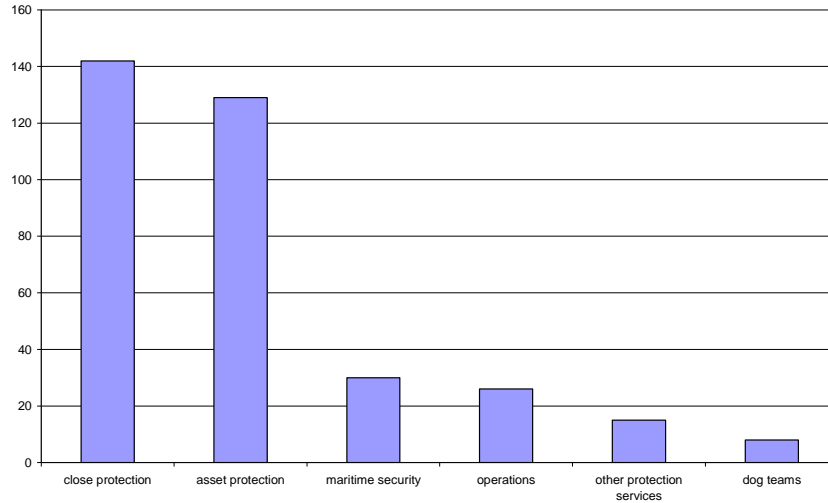
**Figure 11. Number of PMFs Active in Different Sub-sectors**

Viewed this way, about 25% of the different activities occurring in the sector can be classed as protective services, 35% as training and advisory, and 40% (almost half) as support services of various kinds.

Overall, we think this data will alarm some observers and satisfy others. Some people will be alarmed to find out that there are around 200 firms offering military competencies of various kinds for sale in the marketplace. From this perspective, it is rather worrisome that there is an industry that specializes in fielding various kinds of (private) mini-armies to the highest bidder. Others will find this fact reassuring rather than worrisome—for them, a significant number of firms means competition, which means efficiency.

### **Protective and Security Services**

We conducted further analysis of the content of each PM sub-sector. Results for the protective services segment are provided in Figure 12 below.



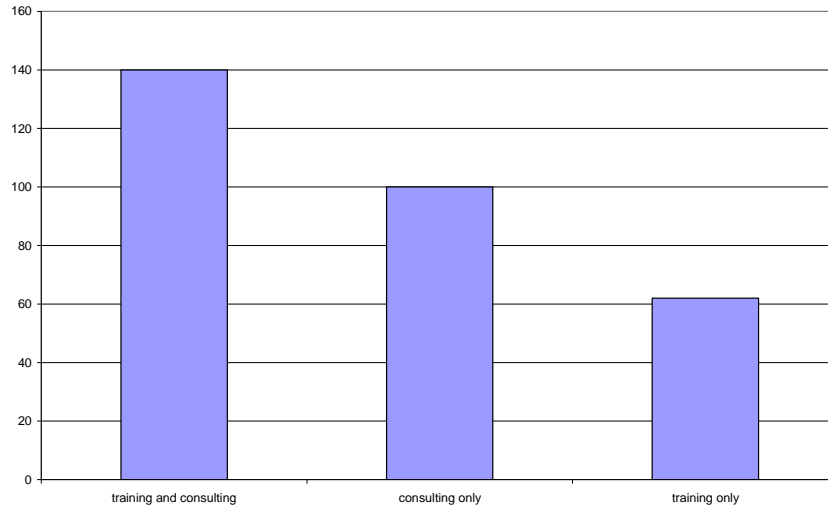
**Figure 12. PMFs Engaged in Protective Services**  
(209 total)

This data indicates that about 2/3 of firms who are active in the provision of protective services are involved in close protection of individuals and assets, i.e., stationary guarding and convoy protection. When an individual thinks of private military and security contractors, this is probably what comes to mind. Our data indicates that this role, indeed, is the mainstay of the protective services business.

However, there are other protective services activities. About 30 firms are known to be active or capable of providing protective services for marine assets. A similar number of firms have capabilities for conducting a variety of operations. The kind of services mentioned here include assault capabilities, rapid reaction forces, and special operations units. A variety of miscellaneous services were also mentioned, as well as the provision of dog teams by a handful of firms.

### **Training and Advisory Services**

Most firms that offer advisory (consulting) services also offer training services. There is considerable overlap between these services, as indicated in Figure 13:



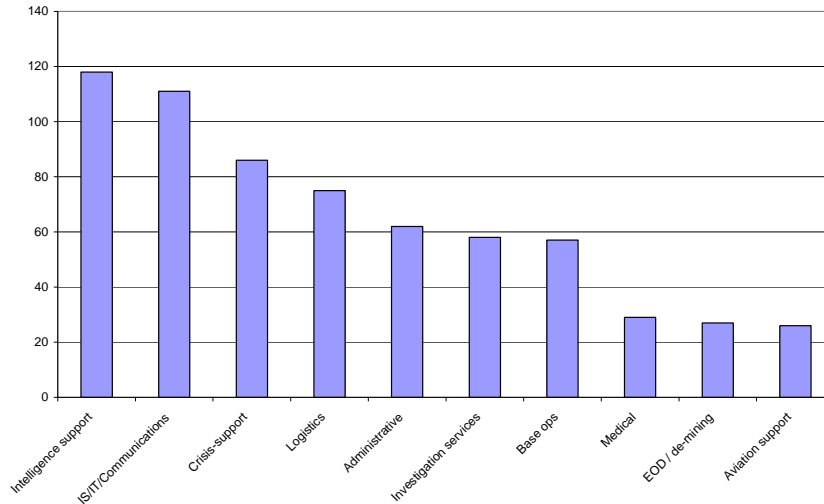
**Figure 13. PMFs Engaged in Training and Advisory Activities**  
(240 firms)

There is a wide range of advisory/consulting services. Commonly mentioned advisory services are risk/threat analysis, counter terrorism and current tactics. However, we found that a very diverse range of advisory capabilities are offered in the marketplace. This suggests that—globally, at least—this sector is quite well-developed and comprehensive in its offerings.

The same is true for training; our data indicates a very diverse range of training services are offered by firms—options too numerous to list. According to our data, approximately 200 firms are active in the training market to some degree or another.

### Support Services

Based on our earlier analysis displayed in Figure 9, it was apparent that diversity is also a hallmark of the support services offered in the PM sector. However, some services are more widely available than others, as indicated by Figure 14 below:

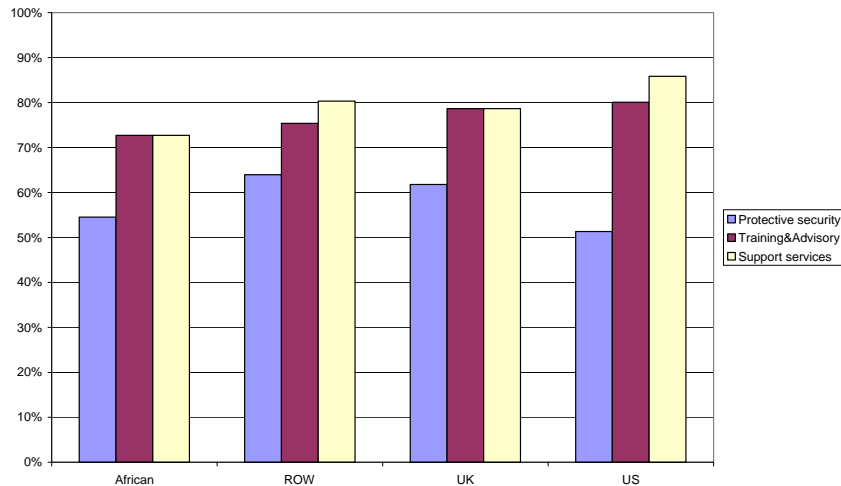


**Figure 14. PMFs Offering Support Services**  
(data from 335 firms)

Two pieces of data seemingly jump out of Figure 14. First, consistent with Avant’s analysis of contracts, intelligence support services are widely available in the sector. This category includes a range of services such as surveillance, intelligence analysis, various counter measures, and information gathering. The number of firms active in this service area indicates that significant competition exists. The second most available service is IS/IT/Communications. Again, the provision of these services appears to be highly competitive, with many firms offering a diverse range of activities in the marketplace.

### **Geographic Distribution of Capabilities: Do Different Geographies Have Different Capability Sets?**

Are some geographies “tipper” than others? Do some geographies have a preponderance of consulting or support services? Based on our data, the following patterns emerged:



**Figure 15. Regional Capabilities Distribution**  
 (% of firms offering services in sub-sectors)

When examining this data, we must remember first that the chart shows percentages, not absolute numbers of each geographic region’s firms active in each capability. This distinction is important because approximately half the industry is based in the US, and this would otherwise distort the data.

The pattern that emerges from Figure 15 is that US firms are slightly more likely to be involved in support services and slightly less likely to be involved in protection services. However, overall, there is little difference between regions when the service mix is analyzed at this level. Of course, the service mix might show a geographic bias in narrower capability segments. We have not yet studied this data.

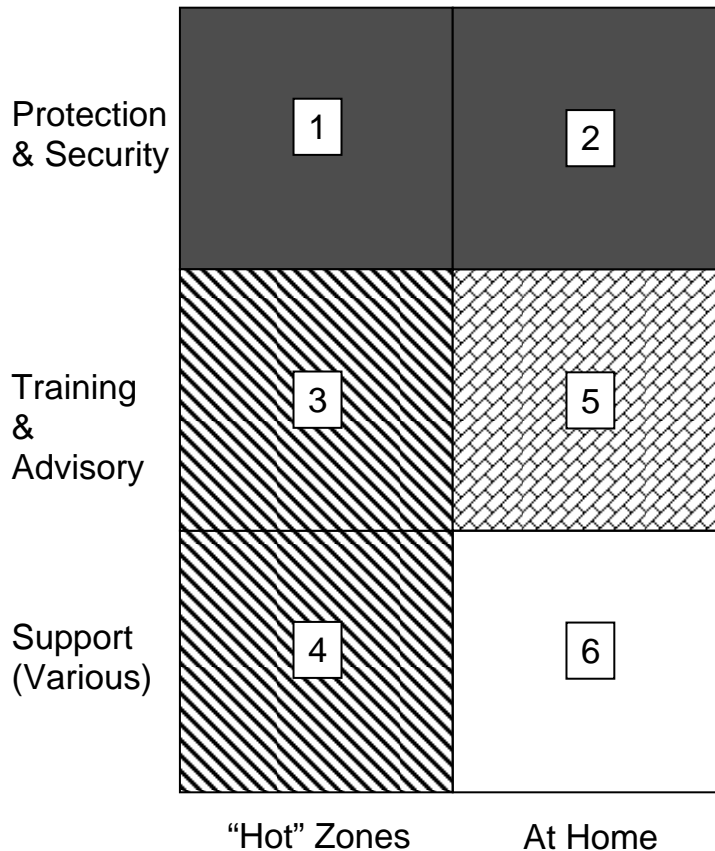
Two observations might be worth noting when we investigate the data on capabilities this way. First, a focus on this lower unit of analysis (i.e., a lower unit of analysis than whole firms) offers us the opportunity to examine clusters of capabilities (for instance, across different geographies) while temporarily ignoring firms. In principle, this might be a reasonable analytical strategy; it is well known that most firms recruit to fill contracts from databases on individuals, and that these individuals typically appear on the databases of more than one firm (Singer, 2003). Therefore, what might be important is the availability of these individuals and their capabilities to groups of firms, rather than what individual firms do. In other words, firms might merely be “shells” that hide underlying capability sets that are more important at the national and regional level than at the firm level.

Second, the overall similarity of the industry across geographic regions points somewhat to the international nature of the business. While there is significant variation in the specific offerings of individual firms, in general about 50% of firms offer protective services; this is true globally—regardless of a firm’s national origins. The geographic proportions hold steady for training/advisory services and support services.



## Reprise: Defining and Bounding the PM Sector

Analysis of PMF capabilities invariably leads us back to the question of what, and who, belongs inside the sector (Ortiz, 2007b). In conducting our survey, we initially used a generous definition of firms “active” within the PM sector in some form or another. But clearly, the definition of “sector” and “participant” is important here. Figure 16 summarizes the various ways we think the sector might be defined:



**Figure 16. Defining the PM Sector**

In this diagram, the vertical axis explains what activity is taking place. The activities are arrayed according to Singer’s “tip of the spear” heuristic. The horizontal axis illustrates where activities are occurring—either in hot zones (how hot, of course, varies) or at home (i.e., some other safe location).

The most restrictive definition of the “industry” would focus on Segments 1 and 2 in this figure. The 2006 IPOA survey used a somewhat restrictive definition of the sector—referring to firms engaged in armed security operations, which yielded a sample of 100 firms. In its report on PMFs, Human Rights First (2008, p. 1) used a similar definition, explaining that:

There is no universal, agreed definition of the term “private security contractor” [...] Human Rights First uses here an essentially functional definition of the term in light of the actual activities of such contractors fielded in Iraq and Afghanistan with a basic security mission—that is, a core mission to protect people (other than themselves) or

things, to include guarding government (and contractors) facilities, protecting government personnel (and other government contractors) and United Nations (U.N.) and other international organization staff as well, and providing security for convoys.

Interestingly, in its 2007 follow-on report to that discussed above, the IPOA broadened its survey to include an identified sample of 334 firms. While we can't be completely sure of the Institute's criteria for inclusion in its sample, we suspect that it reflects Segments 1 and 2 in the diagram above, plus Segments 3 and 4, and possibly some firms in Segment 5.

The two problem zones (or "gray areas") in analyzing the PM sector are Segments 5 and 6. Some elements of Sector 5 fall more easily inside what we believe most analysts would agree as defining the PM sector. For instance, Blackwater's North Carolina training range, which includes various weapons ranges, is sometimes touted as the best in the world for some types of military training. Many aspects of MPRI's (Military Professional Resources, Inc.) advisement activities would also clearly fall in this segment. However, where should we classify activities such as Cubic's virtual training systems? Should we include firms such as Cubic in the PM sector, or exclude it? We think there are arguments on both sides.

Even more problematic is Segment 6 in the diagram. There are two issues here. First, we often cannot tell where the activities of support firms take place based on reports on the industry or on declarations by the firms themselves. Second, there is the question of whether the activities themselves belong inside the industry. IS/IT/communications firms are particularly troublesome in this regard. Let's examine, for example, CACI. It is a major provider of support services to the DoD and to the intelligence communities. Or, we could study Mantech. It builds and maintains databases that track potential terrorists and provides a range of other IT-related support services to the intelligence communities. If these services are largely performed at home, should we define them as inside the PM sector? And what about the services themselves—the things these firms do certainly appear to be a very different kind of business than that performed by DynCorp and ArmorGroup. They are involved in non-traditional types of "warfare." However, according to some arguments, if these types of activities reflect the way conflict is evolving into the future, firms like CACI and Mantech are—arguably—critical precursors of a new wave of private defense-sector firms. Should they be included in our sample of the PM sector, or left out?

It is important to note that in reporting on PM-sector demographics, there are legitimate rationales for using different definitions of the industry. We used an expansive definition of the industry; we included all the segments above.

To conclude, our analysis points out that the private military sector is by no means a unitary industry: it actually is an amalgam of several different elements that have independent drivers and are developing along different trajectories. In our analysis, the evolution of the supply side of the industry is, therefore, rather complex and dynamic. This complexity is partly driven by a set of demand drivers we believe to be richer and more diverse than is often acknowledged. In our analysis, the demand factors driving the long-term evolution of the industry involve the private sector, non-governmental organizations (NGOs), non-military government departments, and international organizations. Short-term demand factors are more military-related and involve co-opting a sector that has, in large part, traditionally served other customers. These factors are dynamically shaping the evolution of a heterogeneous and adaptive industry sector.



## List of References

- ArmorGroup. (2004). *Annual report*. London: Author.
- ArmorGroup. (2007). *Interim report*. London: Author.
- Avant, D. (2005). *The market for force: The consequences of privatizing security*. New York: Cambridge University Press.
- Avant, D. (2007). NGOs, corporations and security transformation in Africa. *International Relations*, 21(2), 143–161.
- Barney, J.B. (1991). Firm resources and sustained competitive advantage. *Journal of Management*, 17(1), 99-120.
- Churchill, W. (2004). From the Pinkertons to the PATRIOT Act: The trajectory of political policing in the United States, 1870 to the present. *The New Centennial Review*, 4(1), 1-72.
- Clinton, W.J. (2007). *Giving*. New York: Knopf.
- Coff, R.W. (1999). When competitive advantage doesn't lead to performance: The resource-based view and stakeholder bargaining power. *Organization Science*, 10(2): 119-133.
- Collier, P. (2007). *The bottom billion: Why the poorest countries are failing and what can be done about it*. Oxford: Oxford University Press.
- DynCorp. (2007). *Annual report*. Falls Church, VA: Author.
- Drohan, M. (2004). *Making a killing: How corporations use armed force to do business*. Toronto: Random House.
- Fishman, C. (2006). *The Wal-Mart effect*. New York: Penguin.
- Fortune. (2007). *Fortune 500 listings*. Retrieved March 31, 2008, from <http://money.cnn.com/magazines/fortune/fortune500/>
- Geroski, P.A. (2003). *The evolution of new markets*. Oxford: Oxford University Press.
- Goodman, L.A. (1961). Snowball sampling. *Annals of Mathematical Statistics*, 32(1), 148-170.
- Hall, P.A. (1993, April). Policy paradigms, social learning, and the state: The case of economic policymaking in Britain. *Comparative Politics*, 25(3), 275-296.
- Human Rights First. (2008). *Private security contractors at war: Ending the culture of impunity*. Retrieved March 31, 2008, from [www.humanrightsfirst.org](http://www.humanrightsfirst.org).
- Jager, T., & Kummel, G. (Eds.). (2007). *Private military and security companies: Chances, problems, pitfalls and prospects—A second essay collection*. Wiesbaden: VS Verlag.
- KBR. (2006). *Annual report*. Houston, TX: Author.
- Kinsey, C. (2007). Private security companies: agents of democracy or simply mercenaries? In T. Jager & G. Kummel (Eds.), *Private military and security companies: Chances, problems, pitfalls and prospects—A second essay collection* (pp. 87-104). Wiesbaden: VS Verlag.
- Kuhn, T.C. (1962). *The structure of scientific revolutions*. Chicago: University of Chicago.
- Lakoff, & Johnson. (1999). *Philosophy in the Flesh*. New York: HarperCollins.
- Ortiz, C. (2007a). Overseas trade in early modernity and the emergence of embryonic private military companies. In T. Jager & G. Kummel (Eds.), *Private military and security companies: Chances, problems, pitfalls and prospects—A second essay collection* (pp. 11-22). Wiesbaden: VS Verlag.
- Ortiz, C. (2007b). The private military company: an entity at the center of overlapping spheres of commercial activity and responsibility. In T. Jager & G. Kummel (Eds.), *Private military and*



*security companies: Chances, problems, pitfalls and prospects—A second essay collection* (pp. 55-68). Wiesbaden: VS Verlag.

International Peace Operations Association (IPOA). (2006). *State of the peace and stability operations industry survey 2006*. Washington, DC: Author.

International Peace Operations Association. (2007). *State of the peace and stability operations industry*. Second annual survey. Washington, DC: Author.

Singer, P.W. (2003). *Corporate warriors: The rise of the privatized military industry*. Ithaca: Cornell University.

Singer, P.W. (2007, September). *Can't win with 'em, can't go to war without 'em: Private military contractors and counterinsurgency* (Brookings Policy Paper Number 4). Retrieved March 31, 2008, from <http://www.brookings.edu/papers/2007/0927militarycontractors.aspx>

Spender. J.C. (1989). *Industry recipes*. Oxford: Blackwell.

Teece, D.J., Pisano, G., & Shuen, A. (1997). Dynamic capabilities and strategic management. *Strategic Management Journal*, 18(7), 509-533.

Tertzakian, P. (2007). *A thousand barrels a second: The coming oil break point and the challenges facing an energy dependent world*. New York: McGraw Hill.

## Acknowledgements

We would like to thank Jim Greene for his sponsorship of this research. Further thanks go to our students Jared Mitchell, Don Robbins, Chuck Dunar, Ercan Sokman, Yusuf Alabarda, Rafal Lisoweic and Ercan Donmez.



THIS PAGE INTENTIONALLY LEFT BLANK



## Panel 20 - Issues in Supply Chain Management

---

<b>Thursday, May 15, 2008</b>	<b>Panel 20 - Issues in Supply Chain Management</b>
	<b>Chair:</b>  <b>Mr. David J. Berteau</b> , Director, Defense Industry, Center for Strategic and International Studies  <b>Papers:</b>  <b><i>Managing the Services Supply Chain in the DoD: An Empirical Study of Current Management Practices</i></b>  <b>Dr. Aruna Apte</b> , Assistant Professor, <b>Dr. Uday Apte</b> , Professor and <b>Dr. Rene Rendon</b> , Senior Lecturer, Naval Postgraduate School  <b><i>Joint Robotics Program</i></b>  <b>Joel Brown</b> , Defense Acquisition University and <b>Paul Varian</b> , Project Manager, Robotics Joint Project  <b><i>The Economic Impact of Open Architecture in the Life-Cycle of Reusable Assets</i></b>  <b>Dr. Geraldo Ferrer</b> , Associate Professor, Naval Postgraduate School

---

**Chair: Mr. David J. Berteau** is the Director of Homeland Security and National Defense for Clark & Weinstock, in place since 2003. The former Director of Syracuse University's National Security Studies Program, Berteau is a Senior Associate at the Center for Strategic and International Studies, an Adjunct Professor at Georgetown University's Security Studies Program and at Syracuse University's Maxwell School of Citizenship and Public Affairs, and a member of the Board of Visitors, Defense Acquisition University. A recognized expert on government and defense management and public-private issues, he regularly lectures and appears at conferences and seminars around the country. He is Fellow of the National Academy of Public Administration, a director of the Procurement Round Table, and a member of several Defense Science Board task forces. He chaired the National Research Council's 2005 study of printed circuit boards for national security.

From 1993 to 2001, Berteau was a Senior Vice President for Science Applications International Corporation (SAIC), the nation's largest employee-owned, high-technology research and development firm. He managed operations that focused on a variety of commercial and government customers. His areas of responsibility included cybersecurity and electronic commerce, software development and lifecycle maintenance, network support, privatization and outsourcing, and defense logistics.

Berteau served in the Defense Department for 12 years. He was Principal Deputy Assistant Secretary of Defense for Production and Logistics from 1990 to 1993. He was responsible for weapons production readiness, industrial base, base closures, defense logistics, installations, procurement, and environment. He also implemented numerous defense management reform initiatives and was responsible for oversight of the Defense Logistics Agency and two new agencies: the Defense





Contract Management Command and the Defense Commissary Agency. He was an acting Assistant Secretary of Defense in both 1990 and 1993.

As Chairman of the 1992 government-wide Defense Conversion Commission, Berteau's report to the Secretary of Defense, *Adjusting to the Drawdown*, developed ways to address the impact of defense reductions on the US economy, on military and civilian defense personnel, and on communities. Nearly all of the commission's recommendations were implemented.

From 1986 through 1989, Berteau was the Deputy Assistant Secretary of Defense for Resource Management & Support. He was responsible for military and civilian manpower and personnel requirements for all defense activities. He chaired the Federal Economic Adjustment Committee and directed the Office of Economic Adjustment, the Training and Performance Data Center, the Defense Manpower Data Center, and the Defense Productivity Program Office, and was the acting Assistant Secretary of Defense for Force Management and Personnel in 1989.

Berteau was Executive Secretary of the Packard Commission (the President's Blue Ribbon Commission on Defense Management) 1985-1986, covering defense acquisition, systems development, budgeting, and management. He was the Assistant to the Deputy Secretary of Defense from 1984 to 1985, serving as Executive Secretary of the DoD Council on Integrity and Management Improvement and the Defense Resources Board. From 1983 to 1984, he was Special Assistant to the DoD Comptroller. Berteau entered the DoD in 1981 as a Presidential Management Intern.

Berteau graduated with a BA from Tulane University in 1971 and subsequently ran several businesses and community organizations and taught in public schools. He received his Master's degree in 1981 from the LBJ School of Public Affairs at the University of Texas and was the Lyndon B. Johnson Congressional Fellow for 1980-81. Berteau received the Secretary of Defense Medals for Distinguished Public Service in 1991 and Outstanding Public Service in 1987 and 1989. His column for *Government Security News* received the Gold Award in 2005 from the American Society of Business Publications Editors. A native of Louisiana, he lives in Derwood, MD, with his wife, Jane Berteau; they have two grown children.

---



# Managing the Services Supply Chain in the Department of Defense: An Empirical Study of Current Management Practices

---

**Presenter: Dr. Aruna Apte** is an Assistant Professor in the department of Logistics, Graduate School of Business and Public Policy, at the Naval Postgraduate School, Monterey, California. She received her PhD in Operations Research from the School of Engineering at the Southern Methodist University in Dallas, Texas. Her earlier education includes a Master's in Mathematics and credits towards a PhD in Mathematics from Temple University, Philadelphia, Pennsylvania. She has taught in the Cox School of Business, School of Engineering and the Department of Mathematics at Southern Methodist University. She has over twenty years of experience in teaching operations management, operations research, and mathematics courses at the undergraduate and graduate levels in the resident and remote programs.

Aruna Apte  
Assistant Professor  
Graduate School of Business and Public Policy  
Naval Postgraduate School  
Monterey, CA 93943-5197  
Tel: (831) 656-7583  
E-mail: [auapte@nps.edu](mailto:auapte@nps.edu)

**Author: Dr. Uday Apte** is Professor of Operations Management at the Graduate School of Business and Public Policy, *Naval Postgraduate School*, Monterey, CA. Before joining NPS, Uday taught at *The Wharton School, University of Pennsylvania*, Philadelphia, and at the *Cox School of Business, Southern Methodist University*, Dallas. He teaches operations management and management science courses in the Executive and Full-time MBA programs. His earlier education includes B. Tech. in Chemical Engineering from *Indian Institute of Technology, Bombay*, MBA from the *Asian Institute of Management*, Manila, Philippines, and Ph.D. in Decision Sciences from *The Wharton School, University of Pennsylvania*, Philadelphia.

Uday has served as a founder and President of the College of Service Operations, Production and Operations Management Society (POMS), as Vice President of POMS, and as guest editor of *Production and Operations Management* journal. Prior to his career in the academia, Uday worked for over ten years in managing operations and information systems in the financial services and utility industries. Since then he has consulted with several major US corporations and international organizations. His recent consulting engagements have focused on process improvement using *Lean Six Sigma* and development of operations strategy.

Areas of Dr. Apte's research interests include managing service operations, supply chain management, technology management, and globalization of information-intensive services. He has published over 30 articles, five of which have won awards from professional societies. His research articles have been published in prestigious journals including *Management Science*, *Interfaces*, *Production and Operations Management*, *Journal of Operations Management*, *Decision Sciences*, *IIE Transactions*, *Interfaces*, and *MIS Quarterly*. He has co-authored two books, *Manufacturing Automation* and, *Managing in the Information Economy*.

Uday Apte, Ph.D.  
Professor  
Graduate School of Business and Public Policy  
Naval Postgraduate School  
Monterey, CA 93943-5197  
Tel: (831) 656-3598  
E-mail: [umapte@nps.edu](mailto:umapte@nps.edu)



**Author: Dr. Rene G. Rendon** is a nationally recognized authority in the areas of supply management, contract management, and project management. He is currently on the faculty of the United States Naval Postgraduate School where he teaches in the MBA and Master of Science programs. Prior to his appointment at the Naval Postgraduate School, he served for more than 22 years as an acquisition and contracting officer in the United States Air Force, retiring at the rank of lieutenant colonel. His Air Force career included assignments as a warranted contracting officer for the Peacekeeper ICBM, Maverick Missile, C-20 (Gulfstream IV), and the F-22 Raptor. He was also a contracting squadron commander for an Air Force pilot training base and the director of contracting for the Air Force's Space Based Infrared satellite system, and the Evolved Expendable Launch Vehicle rocket program.

Rene has taught contract management courses for the UCLA Government Contracts program and was also a senior faculty member for the Keller Graduate School of Management where he taught MBA courses in project management and contract management. He is a graduate of the U. S. Air Force Squadron Officer School, Air Command and Staff College, Air War College, and the Department of Defense Systems Management College. Rene is Level III certified in both Program Management and Contracting under the Defense Acquisition Workforce Improvement Act (DAWIA) program. He is also a Certified Professional Contracts Manager (CPCM) with the National Contract Management Association (NCMA), a Certified Purchasing Manager (C.P.M.) with the Institute for Supply Management (ISM), and a certified Project Management Professional (PMP) with the Project Management Institute (PMI). He has received the prestigious Fellow Award from NCMA, and he was recognized with the United States Air Force Outstanding Officer in Contracting Award. He has also received the NCMA National Education Award and the NCMA Outstanding Fellow Award. Dr. Rendon is a member of the ISM Certification Committee as well as on the Editorial Review Board for the ISM *Inside Supply Management* magazine. He is a member of the NCMA Board of Advisors as well as associate editor for its *Journal of Contract Management*. Dr. Rendon's publications include *Government Contracting Basics* (2007), *U. S. Military Program Management: Lessons Learned & Best Practices* (2007), and *Contract Management Organizational Assessment Tools* (2005). He has also published scholarly articles in the *Contract Management* magazine, the *Journal of Contract Management*, the *Program Manager* magazine, the *Project Management Journal*, and the *PM Network* magazine. He is a frequent speaker at universities and professional conferences and provides consulting to both government and industry.

Rene G. Rendon, D.B.A  
Senior Lecturer  
Graduate School of Business and Public Policy  
Naval Postgraduate School  
Monterey, CA 93945-5197  
Tel: (831) 656-3464  
E-mail: [rgrendon@nps.edu](mailto:rgrendon@nps.edu)

---

## I Introduction

Services acquisition in the US Department of Defense (DoD) has continued to increase in scope and dollars in the past decade. In fact, even considering the high value of weapon systems and large military items purchased in recent years, the DoD has spent more on services than on supplies, equipment and goods (Camm, Blickstein & Venzor, 2004). The acquired services presently cover a very broad set of service activities—including professional, administrative, and management support; construction, repair, and maintenance of facilities and equipment; information technology; research and development, and medical care.

As the DoD's services acquisition continues to increase in scope and dollars, the agency must give greater attention to proper acquisition planning, adequate requirements



definition, sufficient price evaluation, and proper contractor oversight (GAO, 2002). Recently, the Director, Defense Procurement and Acquisition Policy (DPAP) has identified inappropriate use of services contracts in the DoD (Director, DPAP, 2007, March 2) and is taking action to improve contracting for services throughout the Department (Director, DPAP, 2006, August 16). In many ways, the issues affecting services acquisition are similar to those affecting the acquisition of physical supplies and weapon systems. However, the unique characteristics of services and the increasing importance of services acquisition offer a unique and significant opportunity for conducting research in the management of the service supply chain in the Department of Defense.

We have addressed the need for research in the area of services acquisition by undertaking a series of research projects. Thus far, we have completed two research projects; the current research is our third research project in this area.

The first research project was exploratory in nature, wherein we tried to understand the major challenges and opportunities in the service supply chain in the DoD (Apte, Ferrer, Lewis, & Rendon, 2006). As a part of this research study, we conducted in-depth case studies on acquisition of services in three different organizations: Presidio of Monterey, Travis AFB and the Naval Support Detachment Monterey (NSDM). The major conclusions of that research are:

1. The Department of Defense's services acquisition has continued to increase in scope and dollars in the past decade. The GAO found that since FY 1999, the DoD's spending on services has increased by 66%; indeed, in FY 2003, the DoD spent over \$118 billion—or approximately 57% of the DoD's total procurement dollars—on services (GAO, 2005, March). The DoD procures a variety of services, including both the traditional commercial services and services unique to defense. In terms of amount spent, the following four service categories together represent over 50% of total spending on services: (a) professional, administrative, and management support services, (b) construction, repair and maintenance of structure and facilities, (c) equipment maintenance, and (d) information technology services.
2. Presidio of Monterey (POM) has contracted maintenance of about 155 buildings and structures to Presidio Municipal Services Agency (PMSA), a consortium of the cities of Monterey and Seaside. The PMSA agreement has allowed the two cities to apply their expertise to routine municipal services and the Army to focus on its military mission. Through this partnership and contract with PMSA, the POM has realized a 41% reduction in expenses when compared with previous base operation costs and private contracts. We recommend that the DoD explore and evaluate the possibility of establishing such synergistic contractual relations with cities adjacent to other bases in support of their respective operations.
3. Proactive and frequent communications are essential for a successful services contract. We found a successful example of this at Travis AFB, where 60th CONS uses Business Requirement Advisory Groups (BRAGs) as the mechanism for conducting such communications. BRAGs are cross-functional teams made up of personnel representing the functional organizations involved as customers in the services contracts. These cross-functional teams plan and manage the service contracts throughout the service's lifecycle. As the DoD increases the use of centralized contracting organizations and regional contracts, the use of proactive and



frequent communications will be even more essential for the successful management and performance of these contracts.

4. Our visits and interviews at Travis AFB, Presidio of Monterey (POM), Naval Air Station Whidbey Island (NAS WI), and the Naval Support Detachment Monterey (NSDM) confirmed the GAO's finding that: While the Army's and Navy's creation of centralized installation management agencies can potentially create efficiencies and improve the management of the facilities through streamlining and consolidation, implementation of these plans has so far met with mixed results in quality and level of support provided to activities and installations (GAO, 2005, June).
5. The centralization of contracting offices and the use of regional contracts will result in additional dynamics for the DoD's acquisition of services. The Department's use of centralized contracting organizations and regional contracts will require even more proactive and frequent communications between the contracting organization and the customer. Although it is still too early to assess the effectiveness and efficiency of centralized contracting organizations and regional contracts, this research has indicated that centralization and regionalization of services contracts are growing trends in the DoD and will significantly change how services contracts are managed.
6. Given the unique characteristics of services (such as intangibility, co-production, diversity and complexity), establishing service specifications, and measuring and monitoring the quality of delivered service are inherently more complex than with manufactured goods. Hence, it is critical to have onboard a "knowledgeable client" and the necessary number of skilled contracting personnel to define the requirements and to supervise vendors and assure quality of outsourced services. The DoD has been aggressively complying with OMB's *Circular A-76*, which directs all federal government agencies "to rely on the private sector for needed commercial services" (OMB, 2003). This has resulted in dramatic growth in DoD spending on services, with a simultaneous downsizing of the DoD civilian and military acquisition workforce. We believe that the downsizing trend is not in sync with the critical need to have a necessary number of skilled contracting personnel onboard. This could mean that in the DoD's outsourced services, either the needs are not being fully satisfied, or the value for the money spent is not being realized.
7. As the DoD acquires more services than goods, the acquisition of services and the use of service contractors are becoming increasingly critical aspects of the DoD mission. However, the management infrastructure for the acquisition of services is less developed than for the acquisition of products and systems. For example, there is a less-formal program-management approach and lifecycle methodology for the acquisition of services, which is confirmed by the lack of standardization in the business practices associated with the services acquisition process. This results from the fact that the functional personnel currently managing the services programs are not considered members of the DoD acquisition workforce and are typically not provided acquisition training under *Defense Acquisition Workforce Improvement Act (DAWIA)* requirements.

Review of the current literature also shows that the use of a well-defined, disciplined approach and infrastructure for the management of projects is critical for a project's success





in meeting cost, schedule, and performance objectives (Kerzner, 2006). In the absence of a well-defined management infrastructure, project teams are left to create an ad-hoc approach to managing the project. Based on our exploratory research, we believe that this is the current situation in many DoD services acquisition programs. Both the lack of a well-defined program management infrastructure and the lack of a lifecycle approach to services acquisition project management are putting the success of these critical services at risk. The risks of not meeting the service acquisition's cost, schedule, and performance objectives are, consequently, higher in critical DoD service projects. As the DoD increases its acquisition of services—particularly in light of anticipated budget cuts and dwindling resources—the Department must ensure that its service acquisition projects are effectively and efficiently managed.

The lack of a developed program management infrastructure for the acquisition of services was a critical research finding that warranted further study. Thus, our second research project was geared towards studying the program management infrastructure in service supply chain in the DoD. In this research, too, we conducted two additional in-depth case studies and developed a conceptual model of a service lifecycle that can be used to analyze and design the DoD's services acquisition process. In our project report (Apte & Rendon, 2007), we discuss the program-management approach, identify basic project-management concepts, describe how these concepts are being used in the acquisition of defense weapon systems, and recommend how they can be adapted in the acquisition of services in the DoD.

The program-management approach essentially consists of a well-defined, disciplined methodology and infrastructure. The program-management approach also includes a centralized, coordinated management of project activities. This includes the use of a project lifecycle, integrated processes, designated managers with project authority, integrated cross-functional teams, and an enabling organizational structure.

Our research on managing the service supply chain within the DoD, and specifically in the Air Force, has identified the following findings:

The traditional approach to managing services acquisition does not include a disciplined methodology and infrastructure. Nor does it include a centralized, coordinated management of project activities involving the use of the project lifecycle, a designated project manager, integrated cross-functional teams, and an enabling organizational structure.

However, our research did identify two innovative approaches to managing services acquisition programs. The Air Education and Training Command (AETC) approach incorporates a well-defined, disciplined methodology and infrastructure. Through the use of both the Program Management Flight and AETC Contracting Squadron, the AETC is able to provide centralized, coordinated, pre-award management of services acquisition programs. And although in the post-award management, the AETC approach does not maintain an on-site program manager, it does maintain an on-site administrative contracting officer. Thus, regardless of its success, this situation has the potential to result in disparate and broken communications between all parties involved in managing the services acquisition program.

On the other hand, the Air Combat Command (ACC) model for services acquisition management using the Acquisition Management and Integration Center (AMIC) approach includes a well-defined, disciplined methodology and infrastructure, as well as a centralized,





coordinated program-management approach. The AMIC approach is unique in that it provides a cradle-to-grave acquisition approach to services acquisition management. This integrated approach results in management efficiencies to include an effective process orientation, maximum resource availability and maximum training effectiveness.

## II Current Research Focus

The objective of this current research is to develop a more comprehensive understanding of how services acquisition is managed at a wide range of military bases throughout the Department of Defense. This current research is focused on answering the following research questions:

1. What types of services are typically procured at military installations, and what dollar amount is annually spent on these services?
2. What type of acquisition strategy, procurement method, and contracts are used in services acquisition?
3. How is the service acquisition process managed? What management concepts—such as a lifecycle, a program-management or a project-management approach—are used?
4. What type of organization/management structure is used to manage the services acquisition?
5. What training is given to contract and project/program management staff?
6. Are there any significant differences between the way services are acquired and managed in different DoD departments?

### **Development and Review of Survey Instrument**

The methodology for this current research involves the application of a survey instrument recently developed for this specific purpose. The MBA student team of Compton and Meinshausen, under the guidance of Apte, Apte, and Rendon, developed the survey instrument as part of their MBA research project (Compton & Meinshausen, 2007). The developed survey was pilot tested for validity and will be then used to collect additional empirical data regarding the current state of services acquisition management at the installation level across the military departments.

The services acquisition research survey consists of questions focusing on specific demographic data for each military department, major command, region, and military installation. The survey also asks specific questions related to the approach, method, and procedures used in the acquisition of services for specific categories of services. The specific categories of services included in this research are listed in Figure 1. These service categories are considered to be the most common services acquired by the various DoD departments. The 7 service categories included in this research accounted for more than \$83 billion spent on services in FY 2005 and accounted for roughly 87% of expenditures on services.



Service Category	Product/Service Classification (PSC) Code
Professional, administrative, and management support	R
Maintenance and repair of equipment	J
Data processing and telecommunications	D
Medical	Q
Utilities and housekeeping	S
Transportation and travel	V
Maintenance and repair of real property	Z

**Figure 1. Service Categories**

The survey instrument includes core questions related to the methods and procedures used in the acquisition of services for these seven categories of services. These core questions focus on the following areas (Compton & Meinshausen, 2007):

Contract Characteristics. The purpose of this category of questions is to gain insight into the dominant procurement method and contract type used in the acquisition of services at the installation. The characteristics examined in this section are degree of competition (competitively bid or sole-source), contract type (fixed-price or cost-type), and type of contract incentive (incentive-fee or award-fee or award-term).

Acquisition Management Methods. The purpose of this category of questions is to gain insight into the types of management methods and approaches used for the acquisition of these services at each phase of the contract-management process. For each of the contract-management phases, the survey asks whether the phase was conducted at a regional, installation, or some other organizational level. This core question category also focused on whether a project-team approach was typically used in the acquisition of the respective service category at the installation level.

Project-team Approach. The purpose of this category of questions is to explore the installations that identified a project-team approach in the services acquisition management method described above. The questions explore the position of the services acquisition project team leader, such as a Program/Project Manager or Contracting Officer. This category of questions also explored information on the owner, generator, and approving authority of the requirement (the specific service being acquired). This category of questions provides additional insight into how a project-management approach is being used in the acquisition of services.

Service Acquisition Leadership. The purpose of this category of questions is to explore services acquisitions in which a project-management approach was not dominantly used. The questions explore the position of the person leading the services acquisition. This category of questions also explored information on the owner, generator, and approving authority of the requirement (the specific service being acquired).

The last category of core questions is focused on the use of a lifecycle approach, length of assignments for services acquisition management personnel staff, use of market research techniques, level of staffing in services acquisition management, and level of



training of services acquisition management personnel. These questions use a Likert scale to measure the responses.

Finally, the last category of survey questions solicits feedback and any general comments regarding the topic of services acquisition. This survey instrument will also allow the researchers to collect data that will be subsequently analyzed to answer the research questions. This research will then require more sophisticated statistical analysis—as discussed in the next section of this paper.

### III Preliminary Hypothesis

The objective of this study, understanding acquisition of services at diverse military bases, is dependent on the survey responses. By designing the survey in a specific way, we have been able to guide the present and past direction of the study of the responses. We analyzed the preliminary results and recorded the findings. However, we plan to further quantitatively analyze the responses, based on the survey currently in progress, in order to provide rigor to and validation of our conclusions.

#### Planned Quantitative Techniques/Analysis

We plan to analyze the responses statistically to find the proportions of various characteristics and management approaches in principal nodes (depicted in rectangles in Figure 2 and Figure 3) across the seven categories described (Figure 1) in the previous section. In this analysis, an understanding of the causes of predominantly or seldom-used approaches will lead to better insight into the acquisition management methods of services. Figure 2 and Figure 3 describe our investigation of the data across the seven categories.

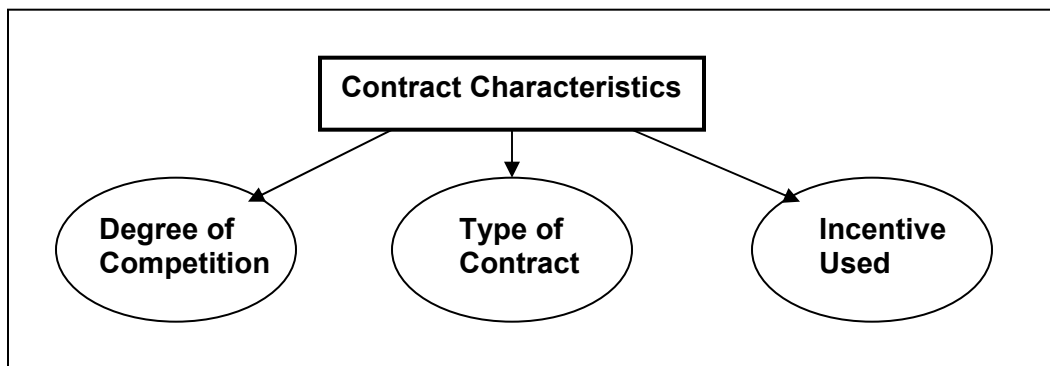
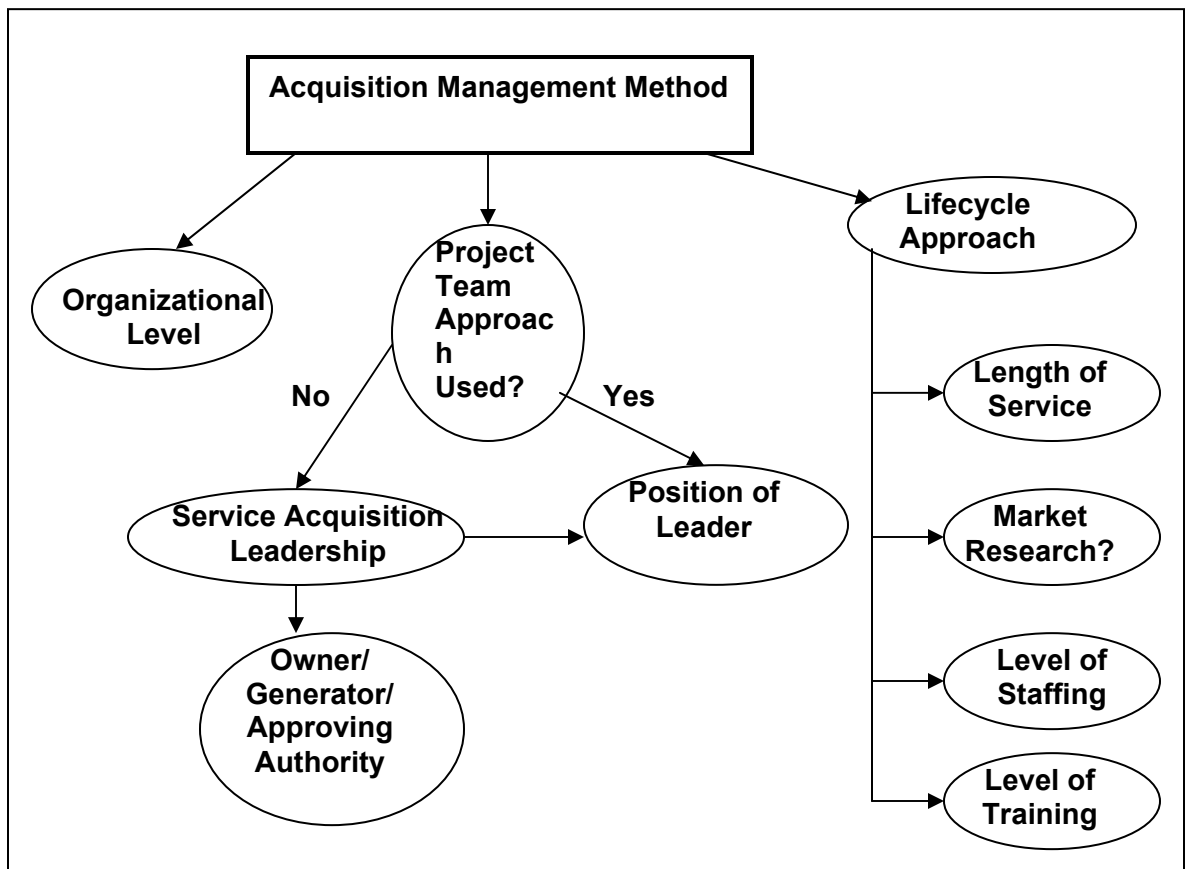


Figure 2. Dominant Procurement Methods



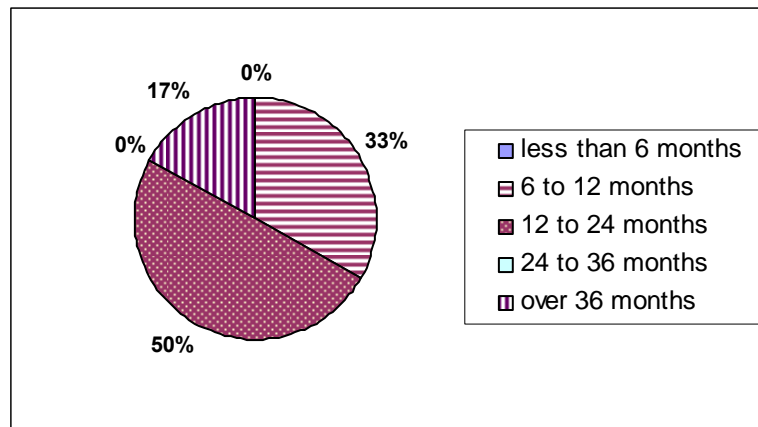
**Figure 3. Management Approaches**

Creation of an appropriate survey to guide the data collection and answer the research questions was a challenging task. Therefore, the responses from the preliminary feedback were time-constrained and, hence, minimal (Compton & Meinshausen, 2007). Currently, two student teams guided by Apte, Apte, and Rendon (one in the Air Force and the other in the Navy) are working with the existing survey engine. We believe these studies will result in sufficient data and will lead to substantial statistical analysis offering insight into the management of service acquisition.

The analysis will explore relations, if they exist, between the secondary nodes (depicted in circles in Figure 2 and Figure 3). We will be interested in finding the correlation between various independent and dependent variables that will represent these secondary nodes and other possible issues discovered. The analysis will also explore whether and how the dollar amount spent has any effect on the contract characteristics or different management approaches, the principal nodes. Based on the level of responses received, we plan to simulate the data if necessary. If the data turns out to be inconclusive in any of these aspects, then that in itself will be an important finding. It may suggest there is no efficient process in place for the acquisition of services—which may, in turn, lead to a recommendation for better management.

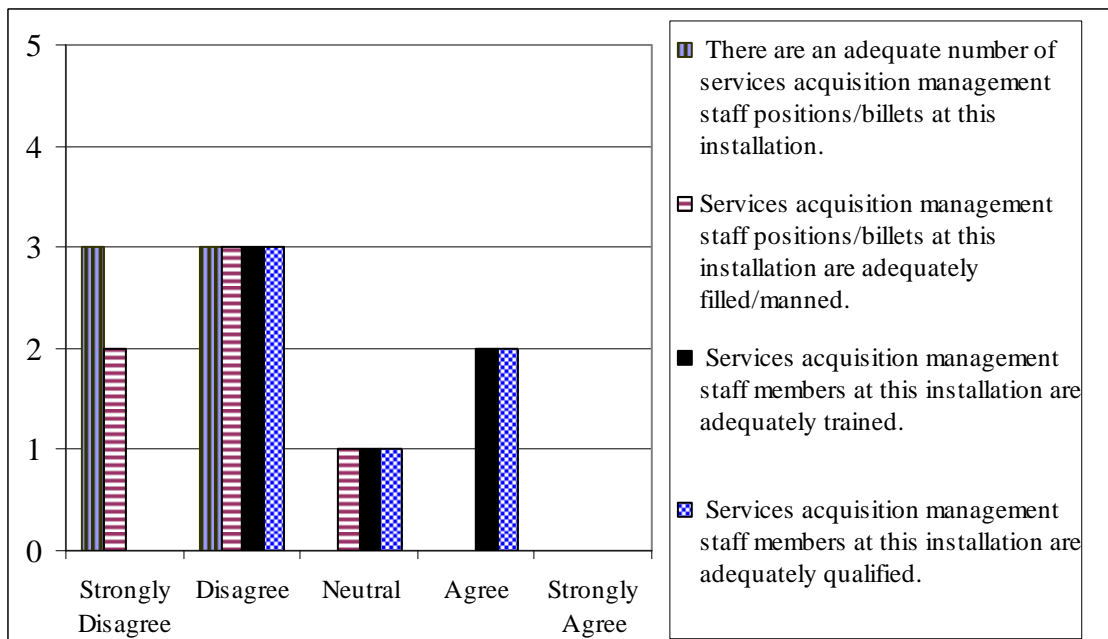
## Preliminary Findings

We now offer some of our findings based on the existing preliminary data. Data collected for the secondary nodes dealing with the length of service of Contracting Officer Representatives and Quality-assurance Evaluators shows that 83% of personnel serve in their billets 2 or less years. This is illustrated in Figure 4. We believe the 33% who serve a year or less imply a high turnover rate. This can negatively impact the quality of contractor surveillance.



**Figure 4. Length of Service**

Data collected for the level of staffing and training (for which results are shown in Figure 5) confirm GAO reports regarding the understaffed, under-trained and under-qualified services acquisition workforce (GAO, 2001). These findings clearly indicate that the acquisition process will not improve until the situation changes.



### Figure 5. Levels of Staffing, Training, and Qualification

As per the secondary node of lifecycle approach, the data collected shows that 50% of the respondents disagreed that a lifecycle approach is used at their respective installation for both routine and non-routine services. Based on this response, Compton and Meinshausen (2007) reached the conclusion that “the lack of a lifecycle approach for routine and non-routine services has the potential to place the government at a higher level of risk due to improper planning for the various phases in a service’s lifecycle” (p. 32).

Finally, Figure 6 shows that respondents primarily agree there is no inconsistency between requirements identification and Statements of Work/Objectives.

Therefore, we infer that the cost increase is not due to miscommunication of requirements and objectives. Data also shows that respondents agreed that market research was conducted for the acquisition of services.

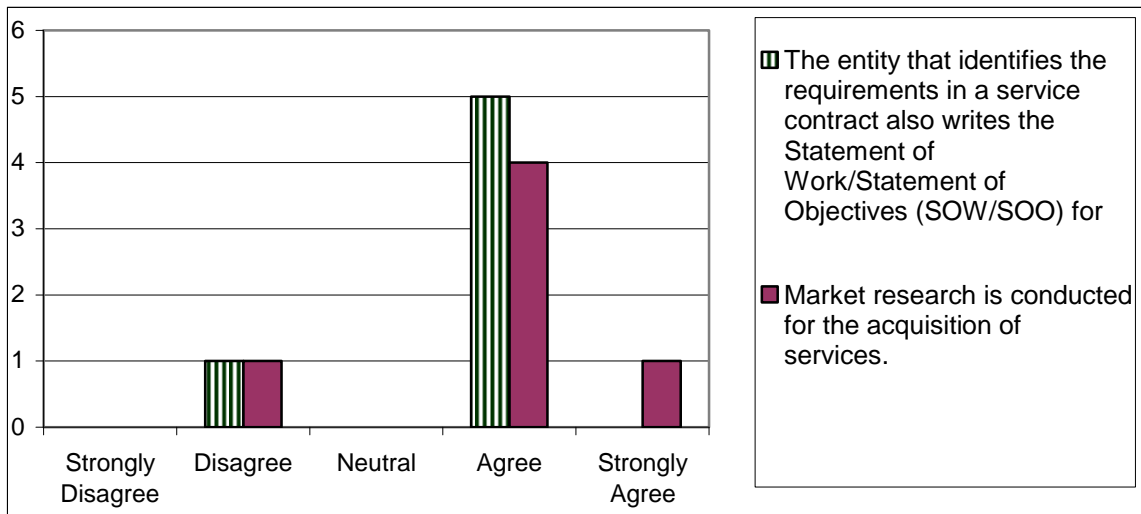


Figure 6. Positive Responses

Thus, based on the data collected so far, our preliminary observations suggest that the current state of services acquisition management at the installation level suffers from several deficiencies; these then result in increasing service contracts. Some of the key aspects are deficit billet and manning levels (which are further aggravated by insufficient training and the inexperience of acquisition personnel), and the lack of strong project-team and lifecycle approaches. Each of these contributes to ineffective and inefficient management.

### List of References

Apte, U., Ferrer, G., Lewis, I., & Rendon, R. (2006). *Managing the service supply chain in the US Department of Defense: Opportunities and challenges* (Technical Report NPS-AM-06-032). Monterey, CA: Acquisition Research Program, Naval Postgraduate School.

Apte, U., & Rendon, R. (2007). *Managing the service supply chain in the U.S. Department of Defense: Implications for the program management infrastructure* (Technical Report NPS-PM-07-126). Monterey, CA: Acquisition Research Program, Naval Postgraduate School.





- Camm, F., Blickstein, I., & Venzor, J. (2004). *Recent large service acquisitions in the Department of Defense*. Santa Monica, CA: RAND National Defense Research Institute.
- Compton, J.A., & Meinshausen, B.A. (2007). *The Department of Defense's management of services acquisition: An empirical analysis* (MBA Professional Report). Monterey, CA: Naval Postgraduate School.
- Director, Defense Procurement and Acquisition Policy (DPAP). (2007, March 2). *Contracts for services*. Memorandum. Washington, DC: Office of the Under Secretary of Defense (AT&L).
- Director, Defense Procurement and Acquisition Policy (DPAP). (2006, August 16). *Government Accountability Office high risk area of contract management*. Memorandum. Washington, DC: Office of the Under Secretary of Defense (AT&L).
- GAO. (2002, January). *Best practices: Taking a strategic approach could improve DOD's acquisition of services* (GAO-02-230). Washington, DC: Author.
- GAO. (2001, November). *Contract management: Improving services acquisition* (GAO-02-179T). Washington, DC: Author.
- GAO. (2005, March). *Contract management: Opportunities to improve surveillance on Department of Defense service contracts* (GAO-05-274). Washington, DC: Author.
- GAO. (2005, June). *Defense infrastructure: Issues need to be addressed in managing and funding base operations and facilities support* (GAO-05-556). Washington, DC: Author.
- Kerzner, H. (2006). *Project management: A systems approach to planning, scheduling and controlling*. Hoboken, NJ: John Wiley & Sons.
- OMB. (2003, May 29). *Performance of commercial activities* (OMB Circular A-76). Washington, DC: Author.



# Joint Robotics Program

---

**Presenter:** Joel Brown, Defense Acquisition University

**Author:** Paul Varian, Project Manager, Robotics Joint Project

---

## Introduction

Sun Tzu wrote first about the importance of logistics over two thousand years ago (Griffith, 1963, pp. 72, 74),<sup>67</sup> followed by Von Clausewitz 150 years ago—who again echoed the importance of logistics to overall mission success (Greene, 1943, pp. 136, 179)<sup>68</sup>; now, logistics is a *Defense Acquisition Workforce Improvement Act* functional area. Since Sun Tzu, much literature, many experiments, lessons learned, and the DoD’s continual searching for better logistics answers have stressed the continued importance of getting the right things to the right place at the right time. Much like human transportation history evolution—beginning first with people walking or running from point a to point b, followed by thousands of years being transported by real “horse” power, then automobiles, airplanes, and rockets—logistics too has progressed over the years: focusing first on Mass-based Supply, then Just-in-Time Supply Chain Management, and now on Sense and Respond logistics.

The Robotic Systems Joint Project Office (RSJPO), an Army-Marine Corps effort that supplies various robots to the AORs of Iraq and Afghanistan, has also evolved through the three logistics methods. During each approach, many positive benefits were discovered. Along with those benefits, there were and are still today challenges to be confronted and overcome. The Robotics Program’s experience and lessons learned since it began “real time” theater support in 2003 can aid all logistics programs by exemplifying the better ways to provide the best logistics with the knowledge, skills, and tools available today. All logistics functions, as shown by the Robotics Program, can be provided incredibly fast, quite inexpensively, and with superior quality and customer satisfaction.

## Mass-based Inventory

For many long years, logistics relied on provisioning and sparing as the logical answer to supporting any weapons system. Numerous logisticians were trained in the art and science of sufficient inventory and spares, which would keep systems functioning for the fielded units anytime and anywhere. Budgets were predicated against these projected numbers. Many logisticians established careers tracking, analyzing, projecting, adjusting, and readjusting Mass-based Support for all weapons systems. This logistics approach did provide weapons system support that could function appropriately in the field (Van Creveld, 1977, pp. 206, 214). Warfighters (customers) were required to learn which spares were critical and in what numbers, while also trying not to have too much inventory of all the wrong things lying about taking up needed space and expending too much available budget.

---

<sup>67</sup> Sun Tzu gives the projected costs for supporting war efforts as well as stating logistics for his time equated to 60% of the total costs incurred.

<sup>68</sup> Von Clausewitz surmises total war requires everything relates, including logistics, to providing the soldier at the right place at the right time to be perfectly effective.



The robotics program first began by utilizing Mass Based logistics to support the initial fielding of 162 robots. Since the majority of suppliers were small businesses (in DoD parlance, “Mom & Pops”) and were finding it difficult to spare or keep up with production, the Program Manager declared that a portion of the total available robots would function as spares. Central Command (CENTCOM) controlled all robots as theater-provided equipment (TPE), rather than granting one of the Services total ownership. However, as the robots were fielded, Command found that the robots worked exceptionally well and replaced warfighters in critical danger missions. The Services would not release critical robotic assets and demanded many more robotic platforms be sent into the field. Very quickly, CENTCOM and the Project Manager realized Mass Based Logistics would not support well the customer’s demand. Another logistics approach was quickly required. What support program would allow the small businesses to produce, supply, and keep up with an ever-increasing field demand?

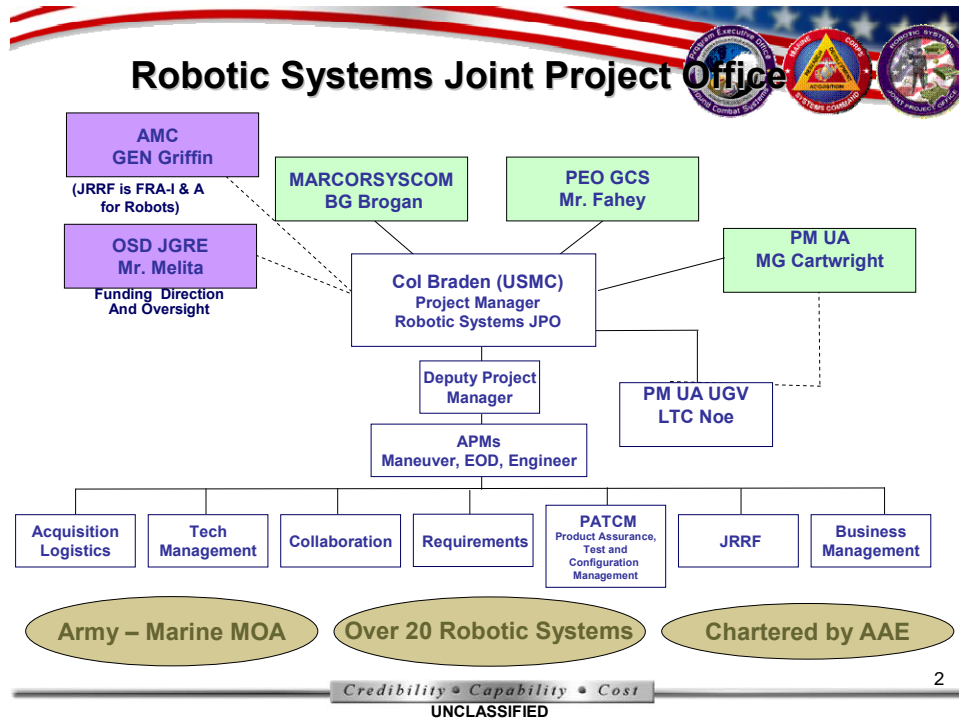
## Just-in-Time

Just-in-Time (J-I-T) logistics support promised to better align suppliers with customers in providing the right item at the right time in the right place. J-I-T also promised to reduce inventories and spares to near zero. In order to achieve these objectives, quality would need to be more strictly monitored; deliveries would need to be timed better; suppliers would need real-time communication with the customers’ system to better predict when they needed to provide needed items. Production needed to be stable so suppliers could more easily meet demand (Kotler, 1997, pp. 214-215). The Robotics program moved toward J-I-T within six months as Massed-based supply could not keep up. The Project Manager and Suppliers gathered data on which robotic parts lasted or failed and how often. Often, the same supply approach (one new robot for one damaged or eliminated robot) was carried over from the Mass-based Approach. Rebuilding damaged robots grew from the J-I-T approach. Both the Project Manager and the Robotic Suppliers needed faster and more accurate information each day. Tracking robots and their status and location in the field became a pressing point. No in-house DoD information system existed to provide this ever-increasing communication need. The Project Manager partnered with Avantix and T&W Communications to create the Catalog Ordering Logistics Tracking System (COLTS) program. The program utilizes UID formats and capabilities to provide the Project Office, as well as the suppliers, with critical, daily information to meet the warfighters’ demands. The J-I-T approach provided more accurate robot fielding. Separate warfighter units only received robots that were truly mission required, rather than potentially hoarding robots as back ups. The logistic footprint was reduced as robots were repaired, rebuilt, or supplied as needed. The biggest challenge for the Robotic Project with J-I-T was caused by interruptions or breaks in the transportation chain—disruptions to the process of getting required robots to their place of need. This is a story we’re all familiar with in air travel: one weather delay for the airlines causes a major ripple effect to all airlines and passengers trying to get to the right place at the right time. Once again, the Robotics Program needed another improved logistics solution!

## Sense and Respond

This Sense and Respond section will flow from a TAV brief given at TACOM in Winter 2007 by the current Robotics Program Manager (Varian, 2007). Sense and Respond logistics arose from the inability of J-I-T to completely satisfy the warfighter customer.





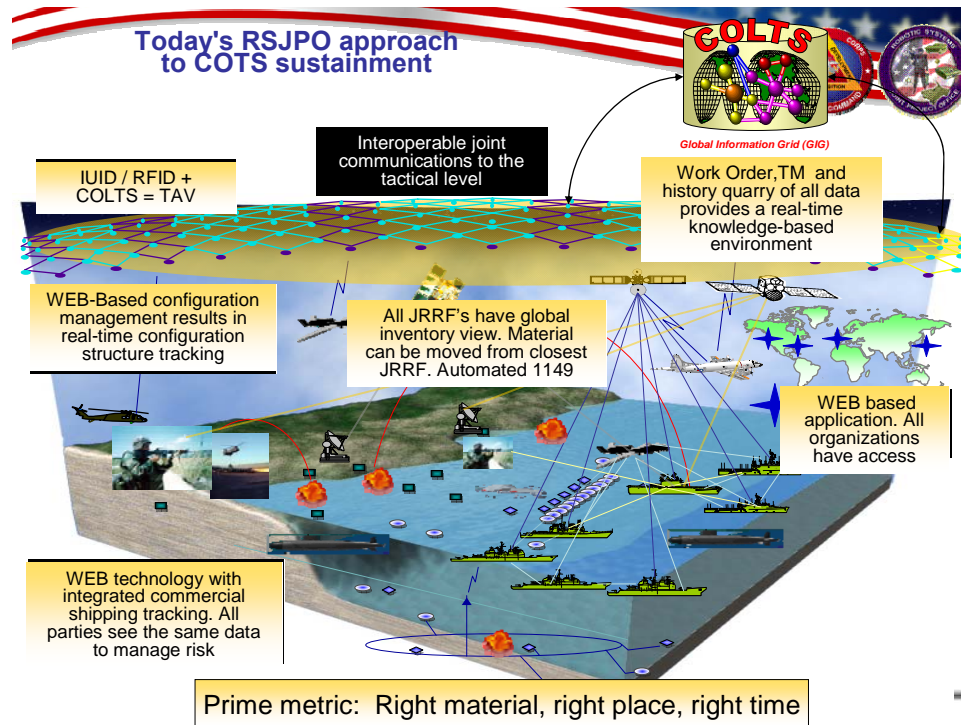
The relationship/JPO chart shows how the Robotics System Joint Program fits into the joint Army/Marine PEO. Joint Robot Repair Fielding (JRRF) is just one of the areas necessary for total Program success.

## Joint Robot Repair Fielding (JRRF)

- Provide in-Theater Support for Joint Service Theater Provided Equipment (TPE) Ground Robots.
- Single “Belly Button” for OIF/OEF Training, Sustainment, Assessment, and Accountability
  - 162 Bots (2004)    - 1800 Bots (2005)    - 4300 bots (Now)    - 6000+ est’d (2008)
- Pre-Deployment Training Sites; JRRTs; and Mobile Training Teams – *Joint Reserves (61%)*
- 4 Hour Robot Turn-Around Standard – *Leveraging “Joint Float Pool Concept”*
- Web-Accessible Real-time Supply Chain Management with integrated IUID/RFID – *Key step toward sense and respond logistics*
  - Accountability    - Parts Reordering    - Reliability Tracking    - Trouble Desk Info
- 2007 Robotic Measures of effectiveness – Robots save lives
  - 25,000 (+) IED Missions Conducted; 15,000 (+) found and cleared with ground robots; 150 Robots Destroyed



The above graphic relates the Robotic program and explains how the customers' needs continue to rapidly expand. The Program has instituted no more than four hours for any robotic replacement, anywhere, anytime.



The figure above relates how the COLTS software program specifically helps achieve the overall goals for Sense and Respond. It is the full implementation of COLTS that allows IUID/RFID to provide a Total Asset Visibility (TAV). To facilitate Sense and Respond, TAV and real-time information flow will be critical to sustainment of tomorrow. The following chart provides the driving tenets for all people involved with the Sense and Respond Robotics logistics support.



## What Joint Robotics Repair Facility Is Doing



1. Define the **WAR-FIGHTER** : As the private or crew member in the heat of it.

2. Understand what is important to the **WAR-FIGHTER**:

- Time
- Equipment that works
- Time

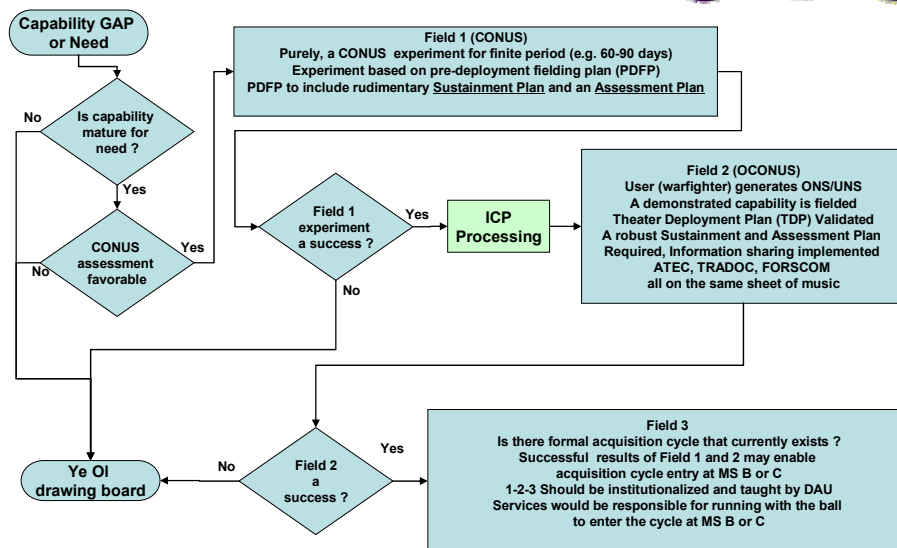
3. Define PBL in a term the **WAR-FIGHTER** understands.

We structure our support to be reactive to the private or crew member in the heat of it. The WAR-FIGHTER receives a robot in 4 hours or less. PERIOD

Credibility • Capability • Cost

By defining processes, the following charts illustrate how the Robotics Program office achieves the above program goals.

## 1,2,3, Process Flow

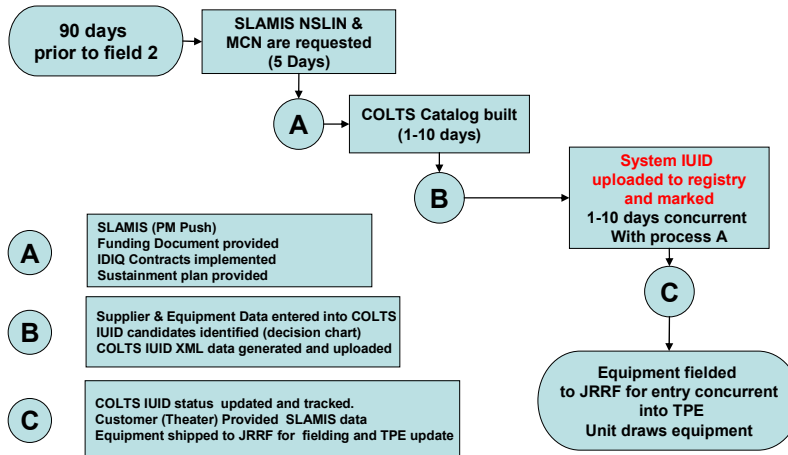


Credibility • Capability • Cost



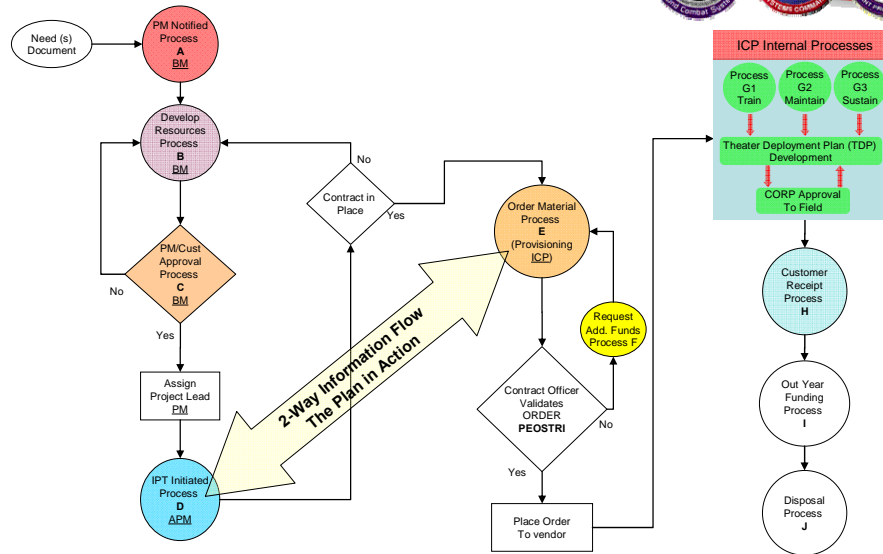


# Inventory Control Point (ICP) Pre-fielding process



Credibility • Capability • Cost

# The JRRF from 40,000 feet



Credibility • Capability • Cost

UNCLASSIFIED

The Robotics Program has completely embraced the IUID (Item-unique Identification) method and is continually discovering capability benefits from the warfighter all the way to the supplier and back again. The following presents just some of these capabilities.



## COLTS (SCM) value to the RSJPO



- Integrated IUID capability. COLTS **USES** the data not just generates the data.
  - Vendors see data and have “buy in” with the IUID process
  - Ability to mark equipment “on site” virtual IUID NOT REQUIRED
- WEB Based centralized database: There is no requirement to “exchange” between databases. It is one stop for common tasks
  - Email notification on trigger events
  - Equipment modification notification generated and tied to equipment
  - All stake holders have access to the data and all see the same thing
  - Data exportable to Excel™ and data interchange is possible i.e. DAASC, ULLS, etc.
  - Reports generation automatically or data mine to customize
- Configuration management up to 15 levels
- Consumption tracking:
  - Real-time parts usage and consumption data.
  - Real-time maintenance data (TTR, Man-hours, WO processing, etc)
- 100% Property accountability:
  - All items are assets. As such nothing is “forgotten” items are always “issued” or “transferred” but never forgotten

Credibility • Capability • Cost

We could spend a great deal of time relating what the Robotics program has achieved by presenting numerous charts and graphs of how improvements have been made over the course of the program. But rather than take up valuable time and space, we thought just the bare facts presented below say it all...



# Return on Investment



- A misplaced hyphen cost \$280K
- IUID enables Serialized Item Maintenance (SIM is a DoD Mandate)
  - IUID Enables real time configuration management
  - IUID Saves repair parts cost
    - Aug 06-Mar 07 \$29M for repair parts on 1 vendor
    - Aug 07-Mar 08 \$ 5M for repair parts on same vendor
- IUID eliminates human induced error
  - Average human has a typing error rate 5.47%. For every 100 key strokes 6 will be wrong

29

Credibility • Capability • Cost

UNCLASSIFIED

## Just the facts (1 Jan 07 – 1 Dec 07)



- COLTS Supply & Maintenance Data
  - 6073 Work orders completed
  - 26,375 maintenance actions
  - 64,419 Inventory events (Parts movement)
  - 78,467 Asset events (Robot actions/movement/repair, etc)
  - 4,816 Items shipped
  - 64 EOD/Engineer robots rebuilt from a destroyed condition. Cost savings approximately 3.2 million dollars.
- IUID integration saves the RSJPO time, money and ultimately lives on the battlefield.
  - No more “lost” data due to human error
  - Shorter repair cycle time as a result of IUID “scan in & scan out”
  - More fidelity of data tracked in COLTS due to IUID decision process.
  - Routine logistics processes streamlined with IUID and hand scanner.
  - Configuration management integrated with all SCM actions. SIM is a reality
- Operational rate on all NS-E/COTS supported platforms has been in excess of 98% since Apr 05.
- In excess of 3307 soldiers trained on robotics operation

Credibility • Capability • Cost

What more need we say about Sense and Respond logistics and the benefits it has provided to the warfighter?



## Conclusion:

Many presenters and numerous authors continue to assert the rate of change in our era will continue to geometrically expand. The Robotics Program since 2003 has rapidly traversed through Mass-based, Just-in-Time, and Sense and Respond logistics approaches, always trying to improve support to the warfighter. Each logistics approach provided benefits and challenges. Each moved into another logistics support scheme built on the previous lessons learned and added new features—with the final goal of reducing the logistics footprint, expending less dollars, and providing the best equipment (which works well when required) to the right warfighter at the right time. The next chart captures each logistic approach and explains why another approach was sought.



Even now, the Robotics Program's Sense and Respond approach is not the final logistics answer. New features (active and passive RFID among others) are being tested, data are being gathered and analyzed, and better processes are being implemented to continually improve the Program's logistics. Other DoD and industry programs should take note and seek out people from this Robotics Program in order to discover better ways to fully support the warfighter. The perfect logistics answer is still to come.

## List of References

- Greene, J.I. (1943). *The living thoughts of Clausewitz*. New York: Longmans, Green and Company.
- Griffith, S.B. (1963). *Sun Tzu. The art of war*. London: Oxford University Press.
- Kotler, P.M. (1997). *Marketing management: Analysis, planning, implementation, and control*. Upper Saddle River, NJ: Prentice Hall.



Van Creveld, M. (1977). *Supplying war: Logistics from Wallenstein to Patton*. Cambridge: Cambridge University Press.

Varian, P. (2007, November 7). *Robotic Systems Joint Program Office: Program manager's brief*. Warren, MI: TACOM.



## Additional Papers:

### Logical Decisions for Contracting: Integrated Decision Technology for Acquisition and Contracting

---

**Author: LCDR Roy Garrison, USN**

**Author: Professor Daniel Dolk, NPS**

**Author: Professor Albert Barreto, NPS**

---

## Abstract

Decision technologies in the form of decision-oriented software systems have proliferated dramatically over the past two decades. Most of these systems tend to be stand-alone systems that are focused on a relatively narrow set of analytical techniques for solving quite specific problems. Many applications, however, require a combination of these technologies to address complex decision-making problems. What is missing in the DSS landscape is an environment in which to create a *DSS Generator* that integrates requisite technologies flexibly and quickly to construct a robust application. We discuss the notion of an integrated decision technology environment (IDTE) in the context of Federal acquisition and contracting. Specifically, we show how the application of existing decision support technologies can assist Federal Government contracting personnel in determining which vendor proposal offers the best overall value to the customer in competitive solicitations. The intent is to establish a model that, when implemented, will ensure that contracting personnel evaluate proposals both consistently and fairly for simplified acquisition procedures (SAP). The proposed system, Logical Decisions for Contracting (LDC), integrates several decision support technologies—including a weight-based ranking model, a multi-criteria decision analysis software system, an expert system, data mining, and a data warehouse. We describe the data, model, knowledge, and user interface components of LDC, present a use case, and show how virtualization technology can facilitate the implementation of this DSS. We conclude by discussing how this approach can be generalized to embrace a fuller portfolio of decision technologies which can, in turn, address a wider array of more complex contracting applications.





# “Alternative Designs for a Joint Command, Control, Communications, Computers, and Intelligence (C4I) Capability Certification Management (JC3M) System”

---

**Author: Gregory A. Miller**

Naval Postgraduate School  
Systems Engineering Department  
777 Dyer Rd.  
Monterey, CA 93943  
Phone: (831) 656-2957  
Fax: (831) 656-3129  
E-mail: [gamiller@nps.edu](mailto:gamiller@nps.edu)

---

## Abstract

US DoD has tended to design Command & Control (C2) systems without consideration for them to interoperate for synergistic effects since each is designed for one warfighting function. As systems have grown biologically into a System of Systems, achievement of mission-level effects has disappointed. Architecting the C2 SoS as a whole is improbable. However, capabilities-based acquisition requires interoperability certification based on delivering a warfighter capability via SoS. Students at the Naval Postgraduate School examined this problem. Their result is the Joint Capability Command and Control Management (JC3M) system. This paper summarizes their efforts. A systems engineering process was applied to elicit requirements, create and simulate alternative solutions, and recommend a solution with lifecycle cost estimates. The simulation tools selected to support the project were CORE, to model function and data flow; Arena, for timing and resource utilization; and POW-ER (Project, Organization, Work for Edge Research), for organizational design and processes. The use of these tools to complement each other is unique. Results indicated that JTEM Capability Test Methodology (CTM) was projected to perform better than other alternatives, with the median LCC. The final recommendation is to monitor JTEM CTM for further maturation as it promises improvements in the utility of C4I SoS evaluations.

**Keywords:** interoperability assessment, modeling, systems engineering

## Introduction

Across the US Department of Defense (DoD), early C4I systems were designed, acquired, and fielded independently. Each addressed a single warfighting function, such as logistics, fire support, or intelligence. Over time, warfighting has grown in complexity, tempo, and scope. Complex endeavors are characterized by participants from not only different services but also from different functional areas. They must respond with agility across a spectrum of action and across smeared boundaries between tradition levels of warfare. The current scenario requires a network-centric force, which in turn requires true C2 interoperability.

Individual C4I systems, most not designed, acquired, or managed as a collective enterprise, are being integrated as such and are forming an interdependent entity—a System of Systems (SoS)—in which emergent behavior dominates and capability delivery cuts across system boundaries. System-level acquisition and testing only result in individual



systems meeting specific performance requirements. The Joint Interoperability Test Command (JITC) tests for end-to-end connections “in the most operationally realistic environment possible” (rather than delivery of desired capability) to assess interoperability. Successful information exchange results in “certification.” This is the baseline system for DoD interoperability certification. However, complex interactions of effects drive changing configurations of C4I SoS with no formally established requirements for performance evaluation. Capability-based testing of a SoS is not well understood. However, the principle to ensure interoperability through testing during development (National Research Council) is still valid.

The baseline interoperability certification process is inadequate because it does not address how the actual SoS supports complex endeavors. Recent revision to the Joint Capabilities Integration and Development System emphasizes that true interoperability is characterized by “end-to-end operational effectiveness [...] for mission accomplishment” (CJCS, 2007). Guidance for writing Capability Development Documents (CDD) requires Net-Ready Key Performance Parameters that assess “the net-ready attributes required for both the technical exchange of information and the end-to-end operational effectiveness of that exchange” (DoD, 2004). This is consistent with the NATO definition of interoperability (NATO, 2002) and that proposed by the Software Engineering Institute (Kasunic & Anderson). Capability Portfolio Managers (DEPSECDEF, 2006, September) and Functional Capabilities Boards (CJCS, 2007) play a role in capabilities-based, cross-program interoperability. Even so, no system can assess the capability of a SoS requiring integration of functions and interfaces across multiple systems. Thus, a JC3M system is important because it provides a process for test planning to verify true interoperability. It documents traceability between capabilities and construction, and it provides confidence that the C4I SoS works.

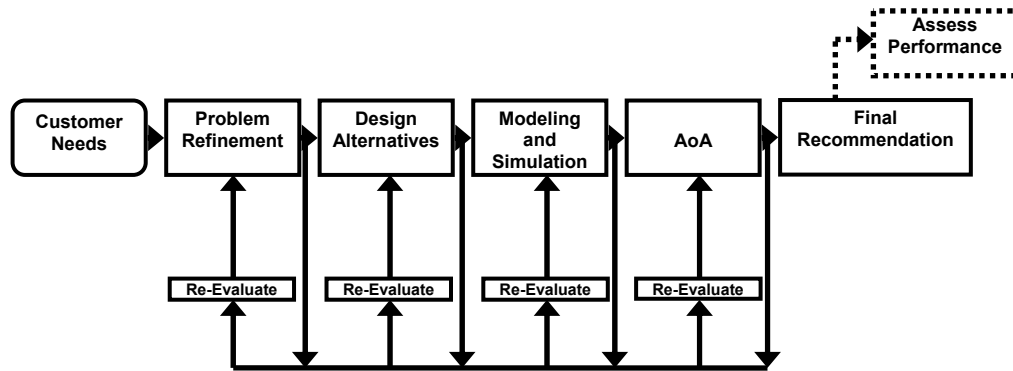
In response to this need, the Joint Test Evaluation Methodology (JTEM) team is addressing Joint SoS interoperability testing at the Office of Secretary of Defense (OSD) level. Marine Corps Systems Command (MARCORSYSCOM), the acquisition organization for the Marine Corps, is approaching the issue from a service perspective. MARCORSYSCOM has tasked the Marine Corps Tactical Systems Support Activity (MCTSSA) to develop Marine Air Ground Task Force (MAGTF) C4I Capability Certification Testing (MC3T), a methodology for managing the MAGTF C4I SoS as a single system. MC3M will manage the MAGTF C4I SoS as a set of SoS-level capabilities, rather than as a fixed hardware or software baseline.

NPS students assigned to the JC3M project team adopted a systems engineering approach to the problem of architecting a C4I SoS assessment system that will identify desired effects-based capabilities and ensure that the system being tested meets those requirements. The JC3M project sought a lifecycle balanced solution for existing test organizations. The processes can be utilized by service and joint test agencies.

## Approach Description

The student design team adapted several systems engineering process models (Acosta et al, 2007) and tailored them to this problem. As illustrated in Figure 1, it begins with identifying a customer’s needs and proceeds through several phases until a final solution is recommended. One can see this is a modification of INCOSE’s SIMILAR (state the problem, investigate alternatives, model the system, integrate, launch the system, assess performance, and re-evaluate) process model (INCOSE, 2007) that incorporates





elements of the Systems Engineering and Design Process (Paulo, 2005) taught at USMA and at NPS.

**Figure 2. A Tailored Systems Engineering Process**

During the problem refinement phase, research into the problem space was conducted, stakeholders were identified and interviewed, functional decomposition was started, and a value system was developed. Based on the preliminary functional analysis and value hierarchy, several alternatives were created. Those alternatives were screened, and ultimately, five alternatives entered the modeling and simulation phase. The predicted performance values generated by the models were used to objectively analyze those alternatives by comparing them to each other along with lifecycle cost estimates. The use of a LCCE as part of the analysis of alternatives in this problem domain is vital. Those testers and test planners must be paid for; it matters little if the final system provides the best solution if that solution is unaffordable. Finally, a solution was recommended, along with caveats. Both the JTEM project and MC3T project will make use of those recommendations.

It should be noted that this team did an excellent job connecting values identified early by stakeholders, supported by a thorough functional analysis. They integrated, into the value hierarchy, the values resulting from modeling and simulation that drove the final decision process.

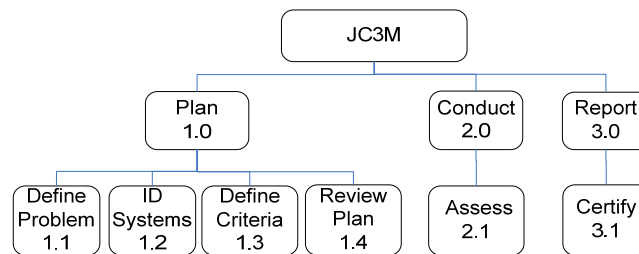
## Problem Refinement & Functional Analysis

Developing a real problem, or effective need, in this situation proved more challenging than anticipated. Stating the central issue so that the stakeholders would receive some utility from the final solution proved slippery. In fact, just identifying the “right” stakeholders was a challenge. From the perspective of C4I system users, any process to certify a system is interoperable within a SoS adds value when that certification signifies the SoS’ ability to support the complex endeavor. Verifying that it conforms to technical standards and that it can exchange data is a necessary, but not sufficient, prerequisite. Whereas, in the acquisition community, a program manager manages resources spent for certification. If test results are compared to criteria outside the scope of his or her program or are not explicitly stated in requirements documents, there is high risk with little gain. The test community, therefore, finds itself in the middle—being the honest broker representing users while still adding value to acquirers. The team focused on the test community, along

with in-house testers inside the acquisition community, as primary stakeholders. The final list included the Joint Interoperability Test Command (JITC), Marine Corps Operational Test and Evaluation Activity (MCOTEA), Army Test and Evaluation Command, Navy Operational Test and Evaluation Force, Air Force Operational Test and Evaluation Center, MCTSSA, and the JTEM Project team under the Director of Operational Test & Evaluation. As this team was mostly composed of MCTSSA employees, a major influence was the new MC3T project, which provided an initial primitive need for a “system that *defines and compares* System of Systems performance measures to warfighter needs in an objective and measurable way” (Finn, 2007). They needed a system that defined threshold values for C4I SoS performance in operational warfighting terms and then a way to obtain those performance measures.

The team examined the larger context of the problem to find the underlying need. The team researched the most up-to-date interoperability certification and the latest direction within the DoD that examines realizing desired capabilities. While the existing directives and instructions seem clear in identifying roles and responsibilities in a traditional sense, little light was shed on the root of the issue. All stakeholders were queried on how they plan a C4I SoS assessment, what resources they use to do so, how component systems under test are identified, how performance requirements are codified, how conflicts are resolved, and what metrics they use to assess their own performance (Acosta et al., 2007). The written questions sought to reveal how they knew they succeeded and what areas were most ripe for improvement. The responses from JTEM and JITC were professional, insightful and frank.

A basic functional hierarchy began to evolve around the three major functions: planning a C4I SoS evaluation, conducting the evaluation, and reporting results. The identification and definition of performance threshold values was of primary concern and all stakeholders seemed to be completely satisfied with their ability to execute and report on an evaluation event. Therefore, the problem scope was focused on the planning phases. Further decomposition resulted in a draft functional model, shown in Figure 2 (Acosta et al., 2007).

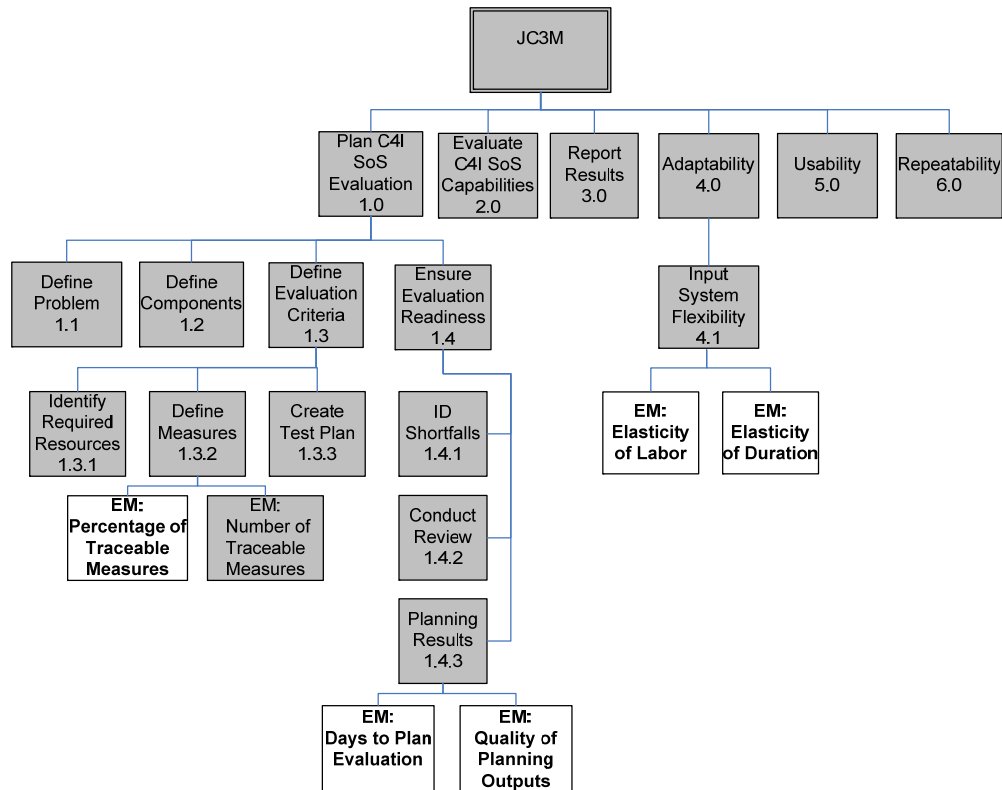


**Figure 3. Initial JC3M Functional Decomposition**

This project focused entirely on function 1.0, Plan a C4I SoS Evaluation. Further functional evaluation identified required inputs and outputs of the system, process activation and termination, and evaluation measures for each of the lowest level functions.

Eventually, several alternatives were to be compared objectively. The basis of that comparison was how well they achieved the functional and non-functional requirements. By combining a complete functional hierarchy with critical non-functional attributes and

assigning evaluation measures to each, a value system was created. This classic systems engineering paradigm completed the initial requirements analysis work. A part of that value hierarchy—with only the critical evaluation measures that were eventually used in the final comparison of alternatives—is in Figure 3. This is a small sample of the information gained through the analysis. However, it is telling because it codifies how designers will know if we “got it right.”



**Figure 4. Part of JC3M Value Hierarchy**  
(Acosta et al., 2007)

The lighter-colored boxes indicate the evaluation measures that defined the needs for a set of modeling tools and that would drive the final analysis. A more complete definition for those elements is provided in Table 1.

	Percentage of Traceable Measures	Days to Plan Evaluation	Quality of Planning Outputs	Elasticity of Labor	Elasticity of Duration
<b>JC3M Function</b>	Define Measures 1.3.2	Planning Results 1.4.3	Planning Results 1.4.3	Input System Flexibility 4.1	Input System Flexibility 4.1
Definition	Alternative generated measures, traceable to stakeholder requirements, divided by the number of measures generated by the alternative.  Ratio level data, from 0–100%	Elapsed time (in days) of planning for C4I SoS evaluation  Integer count $\geq$ 0 days	Assign an overall quality level to the planning documents produced.  Ordinal–Low, Medium, High	Divide percent change in labor hours to conduct planning phase of JC3M by the percent change in systems under test.  Ratio level data from 0– $\infty$	Divide percent change in duration to conduct planning phase of JC3M by the percent change in systems under test.  Ratio level data from 0– $\infty$
Rationale and Relevance	Identifies objectivity of performance measures.  Performance measures traceable to doctrinal references will be perceived as objective, increasing the value of the evaluation.	Predicts SoS evaluations that can be conducted in a year.  Alternatives that permit multiple SoS evaluations generate data to support fielding decisions sooner.	Identifies predicted utility of alternative.  Quality of the planning products drives the overall value of the alternative.	Predicts changes in cost of SoS evaluation based on size.  Can be used to determine most-effective alternative based on SoS size.	Predicts changes in duration of SoS evaluation based on size.  Can be used to determine most-effective alternative based on SoS size.

**Table 1. Evaluation Measure Details**

## Design Alternatives

There were three existing alternatives completed or in the final stages of development in response to the problem at hand. Additionally, the team sought to architect two additional systems. This would present the stakeholders a broad range of possibilities, while keeping the effort required for modeling and simulation manageable.

The first of the known alternatives was the Federation of Systems (FEDOS) system used at MCTSSA in 2005. FEDOS was designed to assess the performance of C4I systems when assembled into the MAGTF C4I SoS. FEDOS began at the order of the Deputy Commander for C4I Integration and Interoperability (C4II) at MARCORSSCOM, that tasked MCTSSA to assess SoS and systems interoperability. A working group of stakeholders in the system developer community decided which systems would participate, which requirements were to be tested, and the schedule of events to include test planning, test conduct, and results reporting.

Because the MAGTF C4I SoS was not designed in compliance with an architecture, there were no overarching SoS performance measures or threshold criteria. This lack of doctrinal performance criteria meant that MCTSSA test personnel had to engage in long, and at times, inconclusive negotiations with stakeholders to define threshold values that





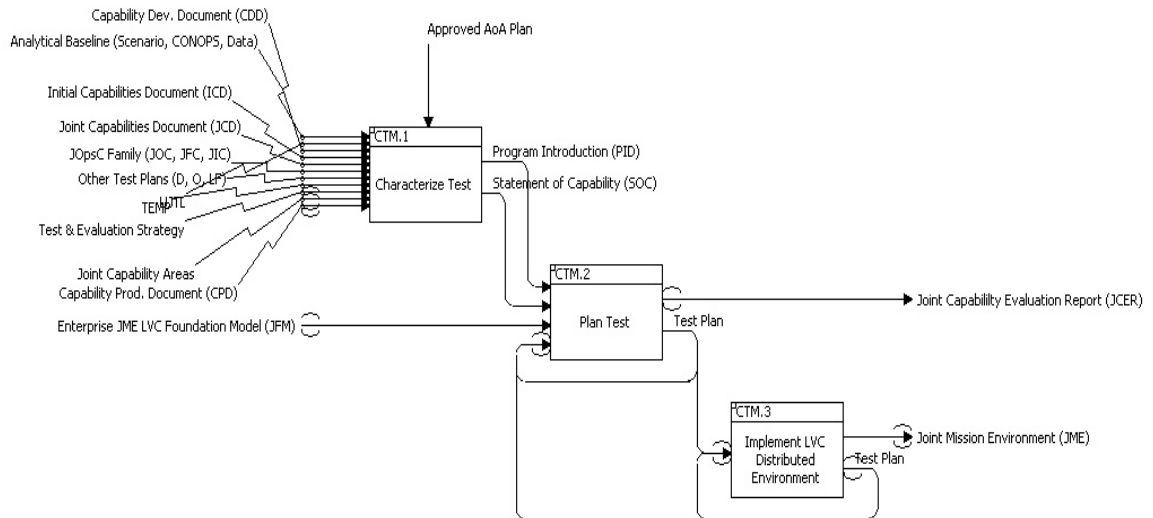
were used to measure performance and determine if components passed or failed the test. The MARCORSYSCOM Product Groups, responsible for developing, fielding, and supporting C4I systems, were not ordered to participate in FEDOS, and a passing grade was not required for a milestone decision. It was perceived as a no-win situation for Product Groups: after a system had successfully passed Operational Tests by demonstrating compliance with system-level performance requirements in their respective CDD or equivalent, FEDOS tested component systems in ways they had not been designed for, but would be used in the field. The acquisition community's perception was that FEDOS was a risk with no off-setting benefit. Despite this shortcoming, FEDOS was relatively successful as the first USMC event specifically designed from the beginning as a SoS evaluation

Because FEDOS is the only alternative solution that has been used by a C4I test organization for a true SoS event, it was considered the "status quo" or baseline JC3M alternative solution. As with all good analyses of alternatives, the first option to consider is "do nothing," or, in this case, "do it like FEDOS."

The second alternative was MAGTF C4I Capability Certification Test (MC3T) developed at MCTSSA as a replacement for FEDOS. Other participants in MC3T development include the Space and Naval Warfare Center (SPAWAR) Systems Center in Charleston, S.C., and the Marine Corps Combat Development Command (MCCDC). More importantly, representatives of the MARCORSYSCOM Product Groups actively participated. Product Group representatives defined a "Capabilities Package" complete with system requirements and DoD Architecture Framework documents that depict the systems under their cognizance. MCTSSA analyzed the Capabilities Package and produced a Consolidated Requirements Assessment (CRA). The CRA was an agreement between the stakeholders on what needed to be tested, the required resources, and the Information Assurance compliance requirements. Once the CRA was approved, MCTSSA produced a Technical Proposal. The Technical Proposal defined the technical solution that the IPT proposed in order to meet the requirements in the Consolidated Requirements Assessment (CRA), including staffing, C4I systems architecture design, monitoring network architecture design, test cases, data capture and analysis plan, information assurance plan, and risk assessment. The Technical Proposal is confirmed, becoming the Technical Solution, which makes up nearly 90% of the Test Plan, includes detailed test procedures with reference documentation. The most promising aspect of MC3T is that MCCDC and MARCORSYSCOM have developed truly integrated architecture framework products. The operational activities doctrinally defined in the Marine Corps Task List are explicitly supported by specific systems working together. The idea that form should follow function in designing for network-centric effects-based operations is consistent with the latest direction for architectures (DoD, 2007).

The third alternative was JTEM's Capability Test Methodology (CTM). The purpose of JTEM is to "develop, test, and evaluate M&P (Methods and Processes) for defining and using a distributed LVC (Live, Virtual, and Constructive) joint test environment to evaluate system performance and joint mission effectiveness [...] focus on developing and enhancing M&P for designing and executing tests of SoS" (JTEM, 2007b). Figure 4 is an IDEF0 representation of the CTM process.





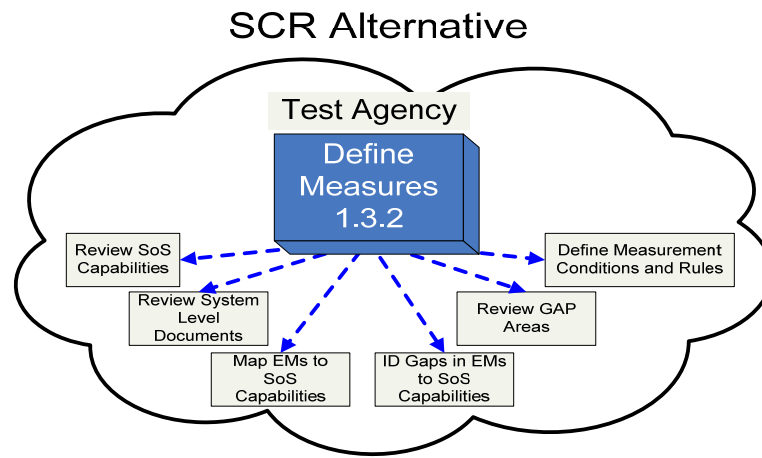
**Figure 5. JTEM CTM in IDEF0**  
(Acosta et al., 2007)

One of the more promising aspects of JTEM's CTM is that test characterization explicitly examines requirements from families of CDDs in the context of missions based on the Universal Joint Task List (UJTL) (CJCS, 2002) and Combatant Command standing operations plans and orders. More detailed descriptions can be found in JTEM's *Joint Test and Evaluation (JT&E), Capability Test Methodology (CTM) Method and Process (M&P) Model Description* (JTEM, CTM, M&P). The complexity of scenarios developed for the LVC test environment reflects real-world complex military action involving disparate forces executing closely linked complicated tasks, including operations other than war.

Two new alternatives that offer significant differences from the existing systems were developed. The classic morphological box (Zwicky process) was applied and guided by the high-level functions identified earlier and then used, in part, to identify evaluation measures. Nine alternatives were initially defined. Through several screening iterations and re-evaluation against the root problem, only two remained: "Systems Capabilities Review" (SCR Alternative) and "Functional Capabilities Board" (FCB Alternative).

The Systems Capabilities Review (SCR) alternative combines two of the original nine alternatives. It is composed of a group of stakeholders: C4I SoS user representatives, test agency representatives, system developers and program managers. The test agency representative chairs the group, which meets, as required, to support a C4I SoS evaluation, at the Systems Command level. Inputs to SCR include source documents such as Capabilities Development Documents (CDD), Operational Requirements Documents, Test and Evaluation Master Plans (TEMP), Concept of Operations documents, Joint Integrating Concepts, Joint Operating Concepts, and system level metrics. First, the SCR reviews SoS capabilities specifications, examines the systems engineering artifacts already created (such as supporting DoD Architecture Framework documents and technical performance measures) and creates a list of implied and stated SoS capabilities. Next, the SCR reviews system-level documents and creates a system-level capabilities list. Third, the SCR maps system-level capabilities to SoS evaluation measures. The SCR identifies gaps in the evaluation measure list and creates the balance of evaluation measures necessary to

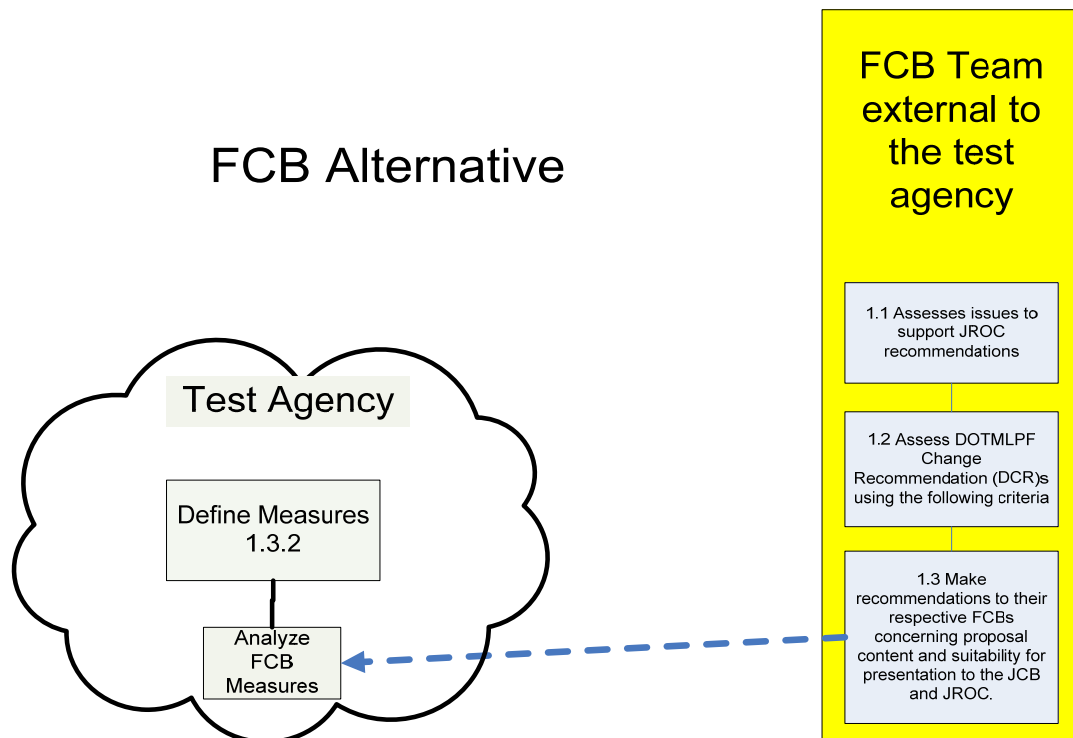
evaluate the performance of the C4I SoS. Figure 5 illustrates how SCR performs the JC3M subfunction 1.3.2 “Define Measures.”



**Figure 6. SCR Alternative Sub-functions**  
(Acosta et al., 2007)

The Functional Capabilities Board (FCB) alternative relies on an existing group—the JCIDS C2 Functional Capabilities Board—to define the performance measures of the SoS. The existing role of FCB is to perform “organization, analysis, and prioritization of joint warfighting capabilities within an assigned functional area” (CJCS, 2007). Inputs to the FCB Alternative include the UJTL and subsets, Concept of Operations (CONOPS) documentation, acquisition program documentation, and system trouble reports. The additional effort proposed in this alternative represents an increase in the work performed by the C2 FCB but is in the same functional area and engages in the similar tasks. Unlike the SCR, the FCB meets on demand, rather than as required, to support SoS evaluations. First, the FCB will identify the configuration of the SoS by determining the component systems. Next, the FCB will identify the SoS capabilities. SoS CONOPS are reviewed to determine evaluation measures. Finally, the FCB will generate the SoS evaluation measure list for use in C4I SoS evaluations. As the systems under the cognizance of the Joint Command & Control Capability Portfolio Manager are explicitly listed (DEPSECDEF, 2006, September), their participation in this alternative would be required. The FCB, under JCIDS, has a long-term mandate, and provides a short-term solution to the lack of SoS performance measures. The relationship between the FCB and C4I test organizations and the list of subtasks needed to complete the Define Measures task, is illustrated in Figure 6. Because the FCB is external to the test organization, some analysis of the performance measures generated by the FCB will be necessary. Additionally, it is understood that a working group within the FCB would perform the required analysis.

## FCB Alternative



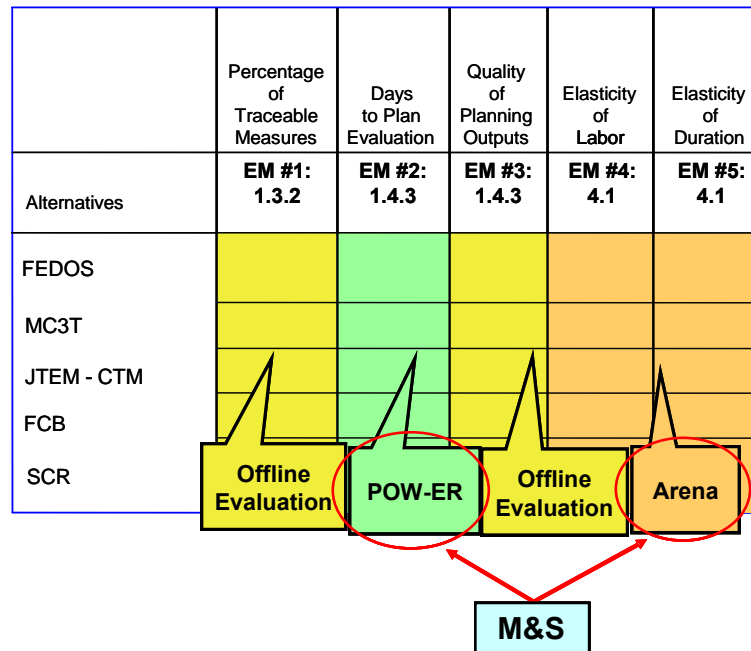
**Figure 7: FCB Alternative Sub-functions**  
(Acosta et al., 2007)

Both of these new alternatives developed by the JC3M team rely on supporting integrated architectures and CONOPS documentation, in addition to documentation normally examined as part of C4I interoperability test preparation. The difference between these alternatives is in the approach taken to complete process 1.3.2 “Define Measures” in the JC3M Functional Hierarchy. The SCR alternative incorporates all tasks as part of the test planning process. The FCB Alternative utilizes an external team that meets year-round to provide capability measures to the test agency.

Five alternatives had now been defined in some detail, as well as evaluation measures to be used to compare those alternatives. Only determining the actual values or values obtained from simulation models for each alternative remained.

## Modeling & Results

Modeling and simulation were used extensively in this project. With the exception of FEDOS, no other alternative under consideration existed. The only means to gather performance data in support of decision-making, short of “building” each alternative, was through simulation. It was the most cost-effective means to obtain the required evaluation measures in a repeatable and objective fashion. Several modeling tools were used to generate the necessary data. Figure 7 illustrates which tools were used to obtain the evaluation measures, which in turn supported later cost-benefit analysis.



**Figure 7: JC3M M&S Supporting Evaluation Measures**  
(Acosta et al., 2007)

Models of each alternative were built based on the functional architectures already created. Elements unique to their physical instantiations were added. In other words, complete functional models in IDEF0 were created with Vitech’s CORE to support the simulation models built in Arena and POW-ER (Project, Organization, and Work for Edge Research). Within Arena and POW-ER, the attributes that differentiated the alternatives from each other—organizational structure, relationships with external systems, and processing of certain inputs—were included. The IDEF0 view of the systems actually proved insightful in terms of explicitly describing the relationship between the functions, at all levels of abstractions, in terms of their inputs and outputs. The models were executed by providing input to simulate a system under test along with its supporting information. The results of several iterations with variations in the input data sets were gathered and used to populate the table of evaluation measures with raw data. The “off-line evaluation” indicated the use of desk-top evaluation by test and development community representatives, similar to the JTEM Rock Drills. It could be considered a kind of human-in-the-loop simulation or just another kind of model or prototype that has been used successfully in this problem domain (JTEM, 2007b).

POW-ER is a project organization modeling and simulation tool that integrates organizational and process views. POW-ER was developed via the Virtual Design Team (VDT) computational modeling research at Stanford University. POW-ER addresses organizational elements that impact the ability to work effectively, including policies and structures (culture, communication, decisions, meetings); staffing, hiring, and training needs for workforce plans. Using POW-ER, the team modeled the organizational structure, the relationship between individuals within those organizations, and individual task allocations. Use of CORE to support functional analysis proved most helpful as it allowed the modelers

to represent the same functional architecture in the refined IDEF0 models as a functional flow in FFBD format. That allowed the creation of PERT-like sequencing of tasks required when modeling work processes in POW-ER. POW-ER's ability to predict and analyze backlogs proved useful designing and troubleshooting alternative models because it allowed the team to identify backlogs in the workflow of models. The analysis of backlogs in the workflow enabled the team to identify the optimized arrangement of tasks and personnel for FCB and SCR since they were created for this project. No such changes were made to the other alternatives. Based on modeler-defined parameters, such as the amount of effort required for each task, the number of full-time equivalents available with appropriate skills and number of hours in a work-week, the POW-ER simulation tool can calculate a project's duration based on simulated duration. Simulated duration factors the "hidden work" that traditional Critical Path Method does not. The "hidden work" associates an amount of rework that delays into each task based upon random variables described for each task by the modeler. The simulated duration provided the number of days to plan an evaluation for each alternative (Acosta et al., 2007).

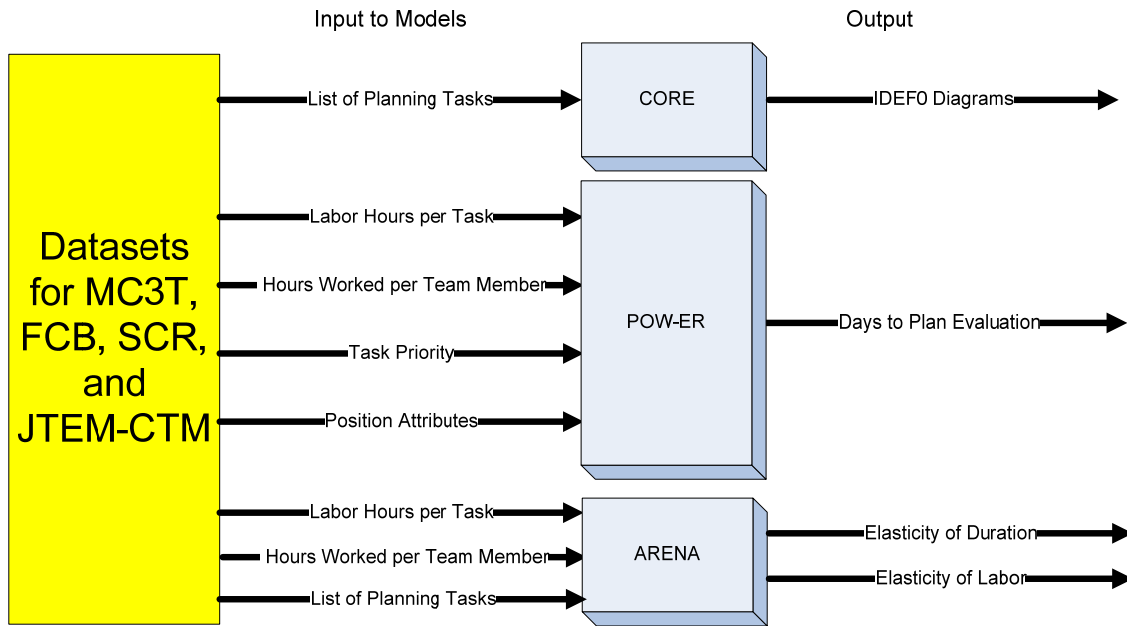
Arena is a commercial tool available from Rockwell Automation. It provides a numerical evaluation of a system by imitating the system's operations or characteristics over time. Arena allowed the team to conduct numerical experiments in order to predict the behavior of an alternative, given a set of conditions. Two evaluation measures required assessing the changes in output as a function of the changes in inputs: Elasticity of Labor and Elasticity of Duration. Arena allowed the team to run simulations on the alternative models with varying sets of inputs. Those input data sets represent the number of systems with their associated documentation that a SoS test event would typically cover. The baseline data set was the group of systems used during the FEDOS event. It included over 90 systems, which included AFATDS, EPLRS, GCCS-J, SINCGARS and TBMCS. There were 14 SoS capabilities examined, including blue force common operational picture, call for fire, common logistics and theater ballistic missile tracking. Variation in the input data set was accomplished by changing the number of individual systems, the number of old SoS capabilities, and the number of new SoS capabilities under test for each data set. The same input data set was used for one run of each alternative, enabling a true head-to-head comparison. The model in Arena was designed so that the subprocess tasks would vary in duration, based on varying the input systems under test. Thus, Arena displayed the output changes of the entire alternative process that corresponded to each of the varying inputs. The output changes (as a percent of the baseline), compared to the percent change of the input became the values for elasticity of duration and elasticity of labor (Acosta et al., 2007).

The models were validated against actual data from the FEDOS event of 2005. Since the original labor hour timesheets for planning that event were available, validating the models was relatively simple. The FEDOS process model was built in CORE, which supported the more elaborate models in POW-ER and Arena. Then, the outputs were compared to the appropriate actual data from FEDOS. The number of labor hours and calendar day predictions from Arena and POW-ER were within 1% of the actual values (Acosta et al., 2007).

Figure 8 summarizes the entire simulation process, including inputs and output values.







**Figure 8. JC3M Modeling Overview**  
(Acosta et al., 2007)

This study represents the first time these modeling tools were used together to complement each other. The simulations predicted key parameters of each alternative design. Without such an approach, no objective or repeatable means to compare the alternatives against the requirements in those areas would have been possible. There is a high degree of confidence in the computer-based measures because the results for the FEDOS models were validated against known historical data and the other models used elements from the data, based on a task mapping from each alternative back to the FEDOS process.

There were still two evaluation measures that could not be determined by computer-based simulation: percent traceable measures and quality of planning outputs. The team was able to engage SMEs from several NAVSEA and NAVAIR field activities to participate in assigning a value for quality of planning products. The team assembled and then presented with all five alternatives. They were then allowed to ask questions in order to ensure clear understanding of how each process worked along with built-in limitations. Each SME responded to specific questions about the predicted quality of planning products coming from each process, with regard to their effectiveness in examining interoperability within a SoS, conformance to standards, and usability. The responses were based on a 4-point Likert scale for each alternative. Percent of traceable measures was more simple to determine once a key assumption was accepted. A proxy was defined as the number of authoritative sources considered, divided by the total number of authoritative sources available. This assumption is valid if there is a linear relationship (as a set) between the number of measures created and the number of sources used in creating those measures.

The final listing of the raw scores is provided in Table 2.

	Percentage of Traceable Measures (%)	Days to Plan Evaluation (Days)	Quality of Planning Outputs (1-4 Likert Scale)	Elasticity of Labor (unit less)	Elasticity of Duration (unit less)
Ideal Value	100%	Less is better	4 is Ideal	Less is better	Less is better
FEDOS	0	140	3.17	0.87	0.87
MC3T	72	121	3.25	0.78	0.78
JTEM CTM	92	73	3.42	1.04	0.83
SCR	92	158	3.00	0.98	0.98
FCB	88	127	2.75	0.72	0.72

**Table 2. Raw Evaluation Measures**

The extremely short duration to plan an event for the JTEM CTM process should be noted. This is to be expected because of that system’s reliance on SMEs in so many different fields, which minimizes cross-checking with multiple stakeholders. On the other hand, the JTEM CTM elasticity of labor was the worst.

Considering so many measures, how could a single “best” alternative be found? The team chose to apply classic multi-attribute utility theory (MAUT). While MAUT has its well-documented limitations, it presents a means to compare the alternatives on a single weighted sum of utilities associated with each evaluation measure. Raw scores are converted to a value or utility score; that value is then multiplied by its global weight, and the resulting weighted values are summed to an overall value. The same SMEs who participated in the process to obtain planning, product-quality figures also participated in the process to determined value functions and swing weights. It should be noted that this team used the mathematically rigorous Wymorian standard scoring functions for value curves to convert raw scores to utility. Additionally, they were very precise about their application of swing weights and rigor of the analytical hierarchy process to obtain weights (Acosta et al., 2007). So, the weaknesses inherent in MAUT were minimized via these tools and techniques. The final total scores are shown in Table 3.

	Percentage of Traceable Measures	Days to Plan Evaluation	Quality of Planning Outputs	Elasticity of Labor	Elasticity of Duration	Overall Utility (0 – 1)
FEDOS	0.00	0.04	0.39	0.06	0.14	0.63
MC3T	0.02	0.05	0.39	0.07	0.16	0.71
JTEM CTM	0.24	0.06	0.40	0.04	0.15	0.89
SCR	0.24	0.02	0.37	0.05	0.10	0.79
FCB	0.22	0.05	0.34	0.08	0.18	0.87

**Table 3. Overall Utility of the Alternatives**

The last step in the process to consolidate the elements of the alternatives was to create a lifecycle cost estimate (LCCE) for each alternative. All costs associated with development, implementation, operations and support through disposal and transition were estimated. Actual data from the FEDOS event, to-date actual costs and to-completion estimates (directly from their respective project managers) for development of JTEM CTM and for development of MC3T were relatively easy to capture, once complete definitions for those phases and cost-breakdown structures were developed. Because the SCR and FCB



alternatives were similar to MC3T in scope and effort, development costs were based on the MC3T numbers. As operations and support for such a system is dominated by labor costs, the annual cost for each alternative was based on applying the prevailing man-hour rates to the labor hour counts from the POW-ER models. Disposal and transition costs were assumed to be the same for each alternative because those efforts were practically identical in terms of level of effort and duration. Table 4 summarizes the LCCE for each alternative.

Alternatives	Lifecycle Year					Total Cost (\$)
	1	2	3	4...9	10	
<b>FEDOS</b>						
Development	0	0	0	0	0	0
Implementation	1,052,527	0	0	0	0	1,052,527
Operational & Maint.	0	419,497	419,497	419,497	2,200	3,908,178
Transition and Disposal	0	0	0	0	50,000	50,000
<b>Total Cost</b>	<b>1,052,527</b>	<b>419,497</b>	<b>419,497</b>	<b>419,497</b>	<b>52,200</b>	<b>5,010,706</b>
<b>MC3T</b>						
Development	0	0	0	0	0	0
Implementation	1,169,414	0	0	0	0	1,169,414
Operational & Maint.	0	525,537	525,537	525,537	2,200	4,756,500
Transition and Disposal	0	0	0	0	50,000	50,000
<b>Total Cost</b>	<b>1,169,414</b>	<b>525,537</b>	<b>525,537</b>	<b>525,537</b>	<b>52,200</b>	<b>5,975,913</b>
<b>JTEM CTM</b>						
Development	1,030,000	2,470,000	0	0	0	3,500,000
Implementation	0	0	1,169,414	0	0	1,169,414
Operational & Maint.	0	0	0	558,535	2,200	2,253,410
Transition and Disposal	0	0	0	0	50,000	50,000
<b>Total Cost</b>	<b>1,030,000</b>	<b>2,470,000</b>	<b>1,169,414</b>	<b>558,535</b>	<b>52,200</b>	<b>6,972,824</b>
<b>FCB</b>						
Development	1,021,835	0	0	0	0	1,021,835
Implementation	1,301,282	0	0	0	0	1,301,282
Operational & Maint.	0	650,223	650,223	650,223	2,200	5,753,985
Transition and Disposal	0	0	0	0	50,000	50,000
<b>Total Cost</b>	<b>2,323,117</b>	<b>650,223</b>	<b>650,223</b>	<b>650,223</b>	<b>52,200</b>	<b>8,127,101</b>
<b>SCR</b>						
Development	952,007	0	0	0	0	952,007
Implementation	1,169,414	0	0	0	0	1,169,414
Operational & Maint.	0	624,451	624,451	624,451	2,200	5,547,811
Transition and Disposal	0	0	0	0	50,000	50,000
<b>Total Cost</b>	<b>2,121,421</b>	<b>624,451</b>	<b>624,451</b>	<b>624,451</b>	<b>52,200</b>	<b>7,719,232</b>

**Table 4. LCCE Summary**

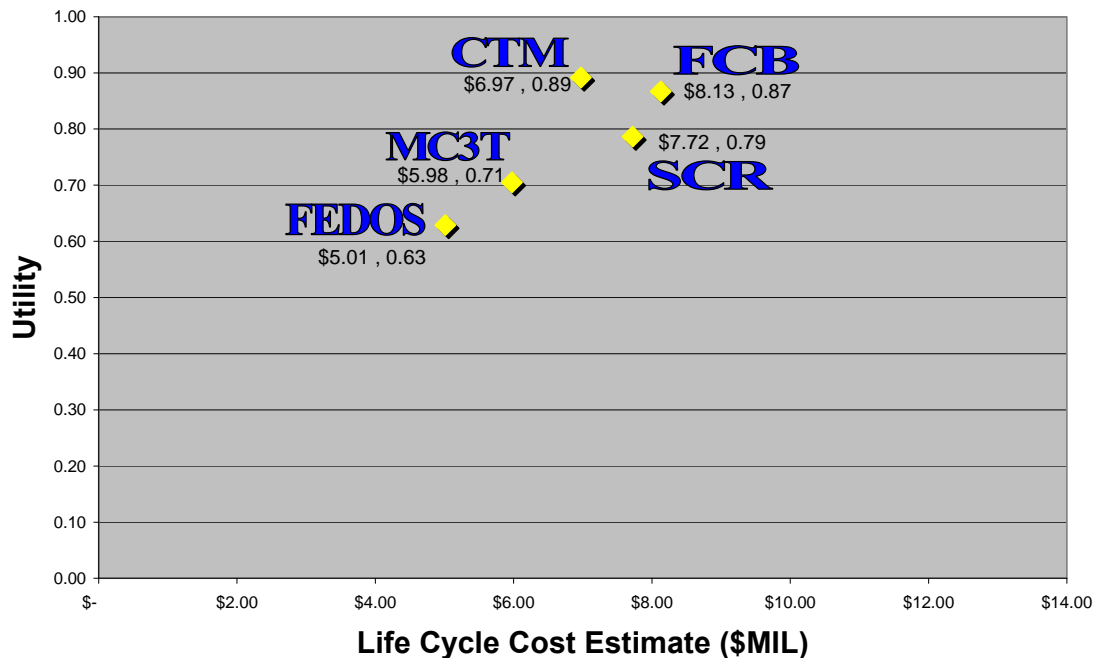
The JC3M team determined the most expensive alternative was the FCB Alternative, at a cost of \$8.13 million over the 10-year projected lifecycle. The team calculated the cost of FCB as a cost to the DoD. While the senior SMEs who generate the performance measures do not charge their efforts directly to a C4I test organizations, their time and effort is a cost to the DoD. The team determined that MC3T was estimated to cost approximately \$960,000 more than FEDOS, which it replaced. While this is nearly a 20% difference, the increase can be directly attributed to the increase in scope, duration, and level of effort



involved in MC3T, which anecdotally supported the increased cost of MC3T (Acosta et al., 2007). More importantly, the development cost for JTEM-CTM is the largest (its development is spread over several years). However, the O&S costs are the lowest. This result is significant because a test agency (or test branch within a development agency) deciding between these options would incur only the costs to implement such an option and then would reap the benefit of keeping annual costs very low.

## Recommendations

A complete analysis of the alternatives based on the preceding data was conducted to determine the “best” alternative. That is, which alternative is projected to provide the greatest utility for the cost? Figure 9 summarizes the results. Again, the utility is a weighted sum of several different attributes, all tied directly to the overall goal of ensuring testing for true interoperability, which is a pre-requisite for any C2 SoS supporting a disparate networked force.



**Figure 9. Utility versus LCC**  
(Acosta et al., 2007)

The JTEM CTM process is projected to perform slightly better than the other options and maintains a LCCE less than the two other alternatives with the closest utility scores. The attributes that drive this performance are the number of days to plan an evaluation, the quality of planning products and the percentage of traceable measures. It should also be noted that a nearly straight line could be drawn between FEDOS, MC3T and FCB. That leaves the SCR Alternative below the line and JTEM CTM above it. However, the better way to examine this figure is to consider an efficient frontier of utility for every cost value. A linear frontier is formed by a line connecting the points for FEDOS, MC3T, and CTM. Thus, the FCB and SCR points are “below” that line—meaning they are less efficient and dominated by CTM.



It must be noted that there is some difference in the confidence we have in the performance measures. Because FEDOS and MC3T were used in actual full-scale SoS test events, their performance is based on historical documentation. JTEM CTM's performance measures are based on desk-top simulations called "rock drills," in which test community personnel exercised certain aspects of the system in an artificial scenario. Additionally, members of the JTEM team participated in this study, which validates nearly every aspect of JTEM CTM that was considered and confirms the expected simulation output. The results from the SCR and FCB alternatives were purely from the simulation. However, the simulation was based on modifying parts of models validated through FEDOS data.

With regard to cost, similar logic can be applied. Those numbers from FEDOS and MC3T are based on actual costs. The cost estimates for the other alternatives, dominated by the labor of annual operations, were driven by the simulation output for number of labor hours.

In spite of the differences in confidence levels, the overall results should be considered valid. The JTEM CTM had the median LCCE, with the lowest O&S cost. This is significant because O&S is a recurring cost, borne by every C4I test organization that implements one of the alternatives. Development costs of JTEM CTM are the largest portion of its LCCE—a nonrecurring cost borne by OSD and not borne by any single C4I test organization.

## Summary & Next Steps

This team was the first to apply a disciplined systems engineering process to the problem of re-engineering the business of testing for C4I interoperability certification. The JTEM project is the only other organization to examine this issue from the perspective of optimizing a lifecycle-balanced solution to meet explicitly stated and quantifiable needs. No group has applied an integrated set of computer-based simulation tools to quantitatively predict the performance of competing options and compare that performance to lifecycle cost. Knowing that C4I systems never perform in a vacuum, but always interoperate as part of a larger SoS, developers and testers will benefit from the results of this study. Ensuring interoperability across services and between civil authorities and multinational organizations begins with an effects-based approach. Only by testing for interoperability against performance measures that are linked to desired effects in the battle-space can C2 SoS support warfighters engaged in complex endeavors.

Based on the insights into the problem domain and potential solutions, there are areas that need further study. The team believed the C4I acquisition and testing communities would benefit from a dedicated Joint C4I SoS manager to provide consistency in an evolving environment. Their role could include documenting C4I SoS capabilities, long-range SoS capabilities planning, and testing requirements management; supporting developmental and operational testing; and addressing ad hoc SoS configuration, resulting from new threats and concepts (Acosta et al., 2007). These roles represent overlap between the acquisition community and those responsible for communicating needed capabilities to them. It is hoped that codifying the relationship between the Joint C2 Capability Portfolio Manager and the C2 FCB will be a move in this direction.

Next, as changes to the SoS configuration are made, the likelihood of capability failures increases. The JC3M team believes risk management strategies should be developed and applied to the C4I SoS. The JC3M team's preliminary list of risks includes



the lack of a single entity responsible for SoS performance; the lack of an objective, repeatable, and methodical approach to address individual system problems impacting SoS functionality; varied levels of maturity of systems within the C4I SoS architecture; and varied interfaces between individual systems.

Finally, systems that are components of the C4I SoS have their capabilities defined as if they exist in a vacuum, and their impact on C4I SoS capabilities is generally not considered. The DoD C4I SoS acquisition process should require component system sponsors to define C4I SoS level effects; establish a funding line for SoS testing; and include SoS effectiveness testing as part of operational testing (Acosta et al., 2007).

## List of References

- Acosta, J., Hoesley, S., Huseth, S., Krider, S., Lamb, J., Martin, C.(2007). *Architecting joint command and control system of systems capability certifications*. Monterey, CA: Naval Postgraduate School.
- CJCS. (2002, July). *Universal joint task list* (CJCS Manual 3500.04C). Washinton, DC: Author.
- CJCS. (2007, May). *Joint capabilities integration and development system* (CJCS Instruction 3170.01F). Washington, DC: Author.
- Command and Control Research Program. (2002). *NATO Code of Best Practice for C2 Assessment*. Washington, DC: Author.
- DoD. (2004, May). *Interoperability and supportability of information technology (IT) and national security systems (NSS)* (DoDD 4630.05). Washington, DC: Author.
- DoD. (2007, April). *Department of defense architecture framework version 1.5 (DoDAF)*. Washington, DC: Author.
- Deputy Secretary of Defense (DEPSECDEF). (2006, September). *Capability portfolio management test case roles, responsibilities, authorities and approaches*. Memorandum. Washington, DC: Author.
- Finn, I. (2007, May 4). [Interview with the JC3M team and Marine Corps Tactical Systems Support Activity]. San Diego, CA.
- International Council on Systems Engineering (INCOSE). (2007, January). *What is system's engineering?* Retrieved March 31, 2008, from <http://www.incose.org/practice/whatissystemseng.aspx>
- Joint Test and Evaluation Methodology (JTEM). (2007a). *Joint test and evaluation (JT&E), capability test methodology (CTM) method and process (M&P) model description*. Washington, DC: Author.
- Joint Test and Evaluation Methodology (JTEM). (2007b). *Joint test and evaluation (JT&E), rock drill event final report*. Approved by Colonel Eileen A. Bjorkman, USAF.
- Kasunic, M., & Anderson, W. (2004, April). *Measuring systems interoperability: Challenges and opportunities* (Technical Note CMU/SEI-2004-TN-003). Pittsburg: Carnegie Mellon University/Software Engineering Institute.
- National Research Council of the National Academy of Sciences. (1999). *Realizing the potential of C4I: Fundamental challenges*. Washington, DC: National Academy Press.
- Paulo, E.P. (2005). Notes for SI4001 (Systems Engineering and Architecture). Monterey, CA: Naval Postgraduate School.





THIS PAGE INTENTIONALLY LEFT BLANK



## 2003 - 2008 Sponsored Research Topics

### **Acquisition Management**

- Software Requirements for OA
- Managing Services Supply Chain
- Acquiring Combat Capability via Public-Private Partnerships (PPPs)
- Knowledge Value Added (KVA) + Real Options (RO) Applied to Shipyard Planning Processes
- Portfolio Optimization via KVA + RO
- MOSA Contracting Implications
- Strategy for Defense Acquisition Research
- Spiral Development
- BCA: Contractor vs. Organic Growth

### **Contract Management**

- USAF IT Commodity Council
- Contractors in 21st Century Combat Zone
- Joint Contingency Contracting
- Navy Contract Writing Guide
- Commodity Sourcing Strategies
- Past Performance in Source Selection
- USMC Contingency Contracting
- Transforming DoD Contract Closeout
- Model for Optimizing Contingency Contracting Planning and Execution

### **Financial Management**

- PPPs and Government Financing
- Energy Saving Contracts/DoD Mobile Assets
- Capital Budgeting for DoD
- Financing DoD Budget via PPPs
- ROI of Information Warfare Systems
- Acquisitions via leasing: MPS case
- Special Termination Liability in MDAPs

### **Human Resources**

- Learning Management Systems
- Tuition Assistance
- Retention
- Indefinite Reenlistment



- Individual Augmentation

### **Logistics Management**

- R-TOC Aegis Microwave Power Tubes
- Privatization-NOSL/NAWCI
- Army LOG MOD
- PBL (4)
- Contractors Supporting Military Operations
- RFID (4)
- Strategic Sourcing
- ASDS Product Support Analysis
- Analysis of LAV Depot Maintenance
- Diffusion/Variability on Vendor Performance Evaluation
- Optimizing CIWS Lifecycle Support (LCS)

### **Program Management**

- Building Collaborative Capacity
- Knowledge, Responsibilities and Decision Rights in MDAPs
- KVA Applied to Aegis and SSDS
- Business Process Reengineering (BPR) for LCS Mission Module Acquisition
- Terminating Your Own Program
- Collaborative IT Tools Leveraging Competence

A complete listing and electronic copies of published research are available on our website:  
[www.acquisitionresearch.org](http://www.acquisitionresearch.org)





ACQUISITION RESEARCH PROGRAM  
GRADUATE SCHOOL OF BUSINESS & PUBLIC POLICY  
NAVAL POSTGRADUATE SCHOOL  
555 DYER ROAD, INGERSOLL HALL  
MONTEREY, CALIFORNIA 93943

[www.acquisitionresearch.org](http://www.acquisitionresearch.org)