



Calhoun: The NPS Institutional Archive

Theses and Dissertations

Thesis Collection

1989

Closed loop pole placement and cost analysis.

Reaves, Joel C.

Monterey, California. Naval Postgraduate School

<http://hdl.handle.net/10945/26914>



Calhoun is a project of the Dudley Knox Library at NPS, furthering the precepts and goals of open government and government transparency. All information contained herein has been approved for release by the NPS Public Affairs Officer.

Dudley Knox Library / Naval Postgraduate School
411 Dyer Road / 1 University Circle
Monterey, California USA 93943

<http://www.nps.edu/library>



NAVAL POSTGRADUATE SCHOOL

Monterey, California



THESIS

R257

CLOSED LOOP POLE PLACEMENT AND COST
ANALYSIS

by

Joel C. Reaves

December 1989

Thesis Advisor

Dr. George J. Thaler

Approved for public release; distribution is unlimited.

Unclassified

Security classification of this page

REPORT DOCUMENTATION PAGE

Report Security Classification Unclassified		1b Restrictive Markings	
Security Classification Authority		3 Distribution Availability of Report	
Declassification Downgrading Schedule		Approved for public release: distribution is unlimited.	
Performing Organization Report Number(s)		5 Monitoring Organization Report Number(s)	
Name of Performing Organization Naval Postgraduate School	6b Office Symbol (if applicable) 32	7a Name of Monitoring Organization Naval Postgraduate School	
Address (city, state, and ZIP code) Monterey, CA 93943-5000		7b Address (city, state, and ZIP code) Monterey, CA 93943-5000	
Name of Funding Sponsoring Organization	8b Office Symbol (if applicable)	9 Procurement Instrument Identification Number	
Address (city, state, and ZIP code)		10 Source of Funding Numbers	
		Program Element No	Project No
		Task No	Work Unit Accession No
Title (include security classification) CLOSED LOOP POLE PLACEMENT AND COST ANALYSIS			
Personal Author(s) Joel C. Reaves			
Type of Report Master's Thesis	13b Time Covered From To	14 Date of Report (year, month, day) December 1989	15 Page Count 96
Supplementary Notation The views expressed in this thesis are those of the author and do not reflect the official policy or position of the Department of Defense or the U.S. Government.			
Cosati Codes		18 Subject Terms (continue on reverse if necessary and identify by block number)	
Field	Group	Subgroup	word processing, Script, GML, text processing.
Abstract (continue on reverse if necessary and identify by block number)			
A study was made of Type I linear control systems, and cost functions, the integral of error squared, and the integral of error squared plus a weighting factor times the control effort squared. The effects of cost function minimization on characteristic root movement for specific third and fourth order systems are investigated to determine if they move into any recognizable patterns. The effects on the unit step response of the minimized systems are also determined. Performance of these minimized systems in the presence of saturation is evaluated specifically to determine if the system response can be improved beyond that of function minimization alone. By minimizing the integral of error squared, IES, the characteristic roots do tend toward the pattern of the IES standard form. Also, by weighting the control effort while minimizing the system error, the characteristic roots do tend toward the Butterworth pattern. Systems designed in this manner do perform better in the presence of saturation.			
Distribution Availability of Abstract <input checked="" type="checkbox"/> unclassified unlimited <input type="checkbox"/> same as report <input type="checkbox"/> DTIC users		21 Abstract Security Classification Unclassified	
2a Name of Responsible Individual Dr. George J. Thaler		22b Telephone (include Area code) (408) 646-2134	22c Office Symbol 62TR

FORM 1473,84 MAR

83 APR edition may be used until exhausted
All other editions are obsolete

security classification of this page

Unclassified

T245546

Approved for public release; distribution is unlimited.

Closed Loop Pole Placement and Cost Analysis

by

Joel C. Reaves
Lieutenant, United States Navy
B.S., U.S. Naval Academy, 1981

Submitted in partial fulfillment of the
requirements for the degree of

MASTER OF SCIENCE IN ELECTRONIC SYSTEMS ENGINEERING

from the

NAVAL POSTGRADUATE SCHOOL
December 1989

ABSTRACT

A study was made of Type I linear control systems, and cost functions, the integral of error squared, and the integral of error squared plus a weighting factor times the control effort squared. The effects of cost function minimization on characteristic root movement for specific third and fourth order systems are investigated to determine if they move into any recognizable patterns. The effects on the unit step response of the minimized systems are also determined. Performance of these minimized systems in the presence of saturation is evaluated specifically to determine if the system response can be improved beyond that of function minimization alone. By minimizing the integral of error squared, IES, the characteristic roots do tend to the pattern of the IES standard form. Also, by weighting the control effort while minimizing the system error, the characteristic roots do tend toward the Butterworth pattern. Systems designed in this manner do perform better in the presence of saturation.

111313
R254
C.1

TABLE OF CONTENTS

I. INTRODUCTION	1
II. SYSTEM DEFINITIONS AND STANDARDIZATION	4
A. PLANT DEFINITIONS	9
1. PLANT 1	9
2. PLANT 2	12
III. THE INTEGRAL OF ERROR SQUARED	14
A. THIRD ORDER SYSTEM	15
B. FOURTH ORDER SYSTEM	17
IV. WEIGHTING THE CONTROL EFFORT	20
A. PLANT 1	21
B. PLANT 2	30
V. SYSTEM PERFORMANCE WITH SATURATION	39
A. MINIMIZED SYSTEM SATURATION RESPONSE	39
1. Third order system	40
2. Fourth Order System	43
B. COMPARISON WITH BODE DESIGN	46
1. Third order system	47
2. Fourth order system	57
VI. CONCLUSIONS	68
APPENDIX	71
REFERENCES	86
INITIAL DISTRIBUTION LIST	87

LIST OF TABLES

Table 1.	CHARACTERISTIC EQUATIONS AND ROOTS	17
Table 2.	THIRD ORDER SYSTEM DESIGN SUMMARY $Q = 0.0005$	26
Table 3.	THIRD ORDER SYSTEM DESIGN SUMMARY $Q = 0.0002$	27
Table 4.	THIRD ORDER SYSTEM DESIGN SUMMARY $Q = 0.000005$	30
Table 5.	CHARACTERISTIC ROOT LOCATIONS $Q = 0.001$	35
Table 6.	CHARACTERISTIC ROOT LOCATIONS $Q = 0.0001$	36
Table 7.	CHARACTERISTIC ROOT LOCATIONS $Q = 0.00001$	38
Table 8.	VALUE OF COST AT DIFFERENT SATURATION LEVELS	43
Table 9.	VALUE OF COST AT DIFFERENT SATURATION LEVELS	46
Table 10.	SATURATION COST SUMMARY BODE AND MINIMIZED DESIGNS	57
Table 11.	IES SATURATION COST SUMMARY BODE AND MINIMIZED DESIGNS	57
Table 12.	SATURATION COST SUMMARY BODE AND MINIMIZED DESIGNS	67
Table 13.	IES SATURATION COST SUMMARY BODE AND MINIMIZED DESIGNS	67

LIST OF FIGURES

Figure 1.	Basic system diagram.	4
Figure 2.	Feedback control arrangement	5
Figure 3.	Common characteristic equation standard forms	6
Figure 4.	Implementation of function minimization	8
Figure 5.	Third order system	11
Figure 6.	Fourth order system	13
Figure 7.	Third order system minimized response	16
Figure 8.	Fourth order system minimized response	18
Figure 9.	Butterworth pattern of characteristic roots	21
Figure 10.	Symmetric root locus for third order system	23
Figure 11.	Third order system minimization results	24
Figure 12.	Third order system minimized unit step response	25
Figure 13.	Third order system minimized unit step response	27
Figure 14.	Third order system minimized unit step response	29
Figure 15.	Symmetric root locus fourth order system	31
Figure 16.	Fourth order system minimization results	32
Figure 17.	Fourth order system minimized unit step response	34
Figure 18.	Unit step response minimized system	36
Figure 19.	Fourth order minimized system	37
Figure 20.	Saturation study system block diagram	40
Figure 21.	Third order system saturation step response	41
Figure 22.	Third order system control effort changes	42
Figure 23.	Fourth order system saturation response	44
Figure 24.	Fourth order system control effort changes	45
Figure 25.	Implementation of Bode design	47
Figure 26.	Bode and minimized design unit step response	48
Figure 27.	Control effort for Bode and minimized design, no saturation	49
Figure 28.	Bode design limiter placement	50
Figure 29.	Bode and minimized designs, saturation level	51
Figure 30.	Control effort changes, saturation level	52
Figure 31.	Bode and minimized system response, saturation level	53

Figure 32.	Control effort changes, saturation level	54
Figure 33.	Bode and minimized system response, saturation level	55
Figure 34.	Control effort changes, saturation level	56
Figure 35.	Bode and minimized design unit step response	59
Figure 36.	Control effort for Bode and minimized designs, no saturation	60
Figure 37.	Bode and minimized design step response, saturation level	61
Figure 38.	Control effort changes saturation level	62
Figure 39.	Bode and minimized design step response, saturation level	63
Figure 40.	Control effort changes, saturation level	64
Figure 41.	Bode and minimized design step response, saturation level	65
Figure 42.	Control effort changes, saturation level	66

ACKNOWLEDGEMENTS

To extend a most gracious thanks to God for providing me with the health, will, and understanding to complete this task. To the United States Navy for affording me the opportunity to attend the Naval Postgraduate School. To my advisor and friend Dr. George J. Thaler for his patience and guidance. Without his help completion of this thesis would not have been possible. And, last but not least to my wife, Madelyn, for her assistance in typing and moral support while completing this requirement.

I. INTRODUCTION

There are numerous methods which can be used to design linear control systems. The primary objective of the different techniques available is to give accurate control of the system output in steady state. However, the transient response of these systems represents the brunt of the problem for the design engineer. Of course the system must be stable, but more important it must reach steady state in an acceptable fashion. Hence, system performance criteria are given to the designer which dictate desired system performance during the transient and steady state portions of system operation. In general, these specifications, particularly maximum overshoot, settling time and steady state accuracy determine the ease or difficulty in designing a given system. In some cases they may make one method of design more suitable than another, but in all cases the dynamic response of a linear control system is determined by the roots of the characteristic equation.

The classical methods for control design (i.e., Bode, root locus and parameter plane) give a dominant pair of complex roots and involve trial and error. More direct methods such as pole placement or the use of standard forms can significantly reduce the amount of time required to complete the design. But in all cases, no matter what design method is used, the roots of the characteristic equation are placed to give the desired system performance. Using the classical methods, the specific locations of the systems characteristic roots are not known. One simply designs a compensator, be it cascade or feedback, and tests the system to see if it meets specifications. However, using the more direct methods, be it by standard form or pole placement, each of the characteristic roots are moved about specific locations in the s -plane until desired dynamic performance is achieved.

For more complex systems, it may not be reasonably possible to place all the characteristic roots in specific locations, or it may take an unrealistic number of trials to achieve the desired dynamic response using the trial and error classical methods. How then is this system to be synthesized? One way is through the use of performance indices otherwise known as cost functions. Since the primary objective of most control systems is to give accurate control of the system output in steady state, if we minimize or control some function of the system error, E , the best possible system performance can be obtained. Some of the more common cost functions include

$$J = \int_0^{\infty} E^2 dt \quad (1.0)$$

or

$$J = \int_0^{\infty} |E| t dt \quad (1.1)$$

where the best system is defined to be that which provides the minimum value of the integral.

If full state feedback is used, given that all states are available, each coefficient of the characteristic equation would be variable, and this would allow complete minimization of the given cost function. Hence, a particular closed loop root pattern would result, producing a particular transient response which may or may not meet specifications.

In order to gain a better appreciation of these cost functions a more common form given as

$$J = \int_0^{\infty} (X^T Q X + U^T R U) dt \quad (1.2)$$

where X is defined as the state vector. The vector U is defined as the control input vector, and Q and R are symmetric matrices, called weighting matrices. By considering only the time variation of the states, the transient response, the cost function is reduced to

$$J = \int_0^{\infty} X^T Q X dt \quad (1.3)$$

Defining the states such that

$$X_1 = E \quad (1.4)$$

$$X_2 = \frac{dE}{dt} \quad (1.5)$$

$$X_3 = \frac{d^2E}{dt^2}, \dots \quad (1.6)$$

and giving zero weight to all derivatives, the cost function reduces to

$$J = \int_0^{\infty} X_1^2 dt = \int_0^{\infty} E^2 dt \quad (1.7)$$

Better transient response can be obtained by weighting some or all of the other states. It must be pointed out, however, that the process of choosing values for the weighting matrix is arbitrary and the transient response obtained will depend on the values chosen for the weighting matrix. This in turn reduces the procedure to a trial and error method where the best design must be chosen by inspection of the simulation results. [Ref. 1]

The main thrust of this study is to examine the relationships, if they exist, between specific cost functions and the closed loop roots of arbitrarily chosen plants. That is to say, for a given cost function, do the closed loop characteristic roots tend to a particular pattern? How does weighting the control effort of a given cost function affect the system root pattern? How does the system perform in the presence of saturation? Can any specific conclusions or generalizations be reached? In order to answer these questions third and fourth order systems will be studied.

II. SYSTEM DEFINITIONS AND STANDARDIZATION

The results obtained from the study of a particular control system are in most cases unique to that system. Performance requirements can make the design of one system easy to engineer in one case and difficult in another, even though the same performance requirements are used. In order to obtain data which can be compared, the methods used to derive this data will be common to all systems studied. These systems, which will be defined later, are all pole plants and are arbitrarily chosen so that actual system performance is not known beforehand.

This case study is concerned with the closed loop roots of subject systems. Even though the characteristic roots are not placed in specific locations as a matter of procedure, this is precisely what is done. A block diagram of a typical closed loop system is shown in Fig. 1. Here R is the system input, which will be a unit step function. E is the system error, U is the control effort, and C is the system output. K is a scalar gain and $G(s)$ is the open loop transfer function.

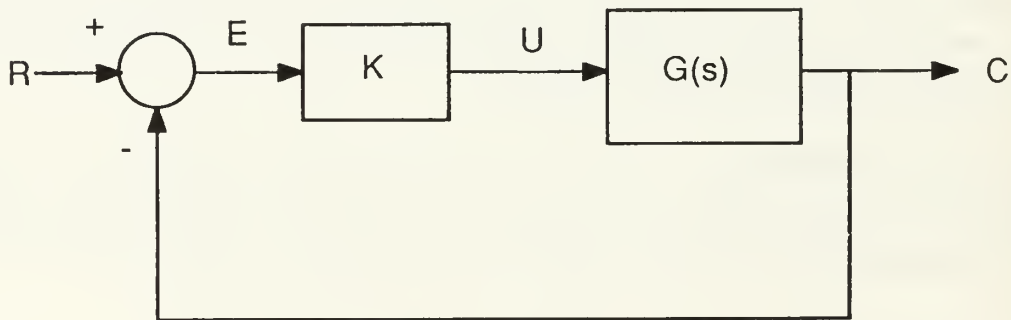

Figure 1. Basic system diagram.

Feedback control is used in this study as a matter of convenience. Simply put, feedback control is the use of a present system condition to influence its condition in the

future. It is used here to shape the system's transient response. Again it is pointed out that, in shaping the system's transient response, the characteristic roots are moved about the s-plane until a location is found which gives the desired response. The basic form of feedback control to be used is shown in Fig. 2.

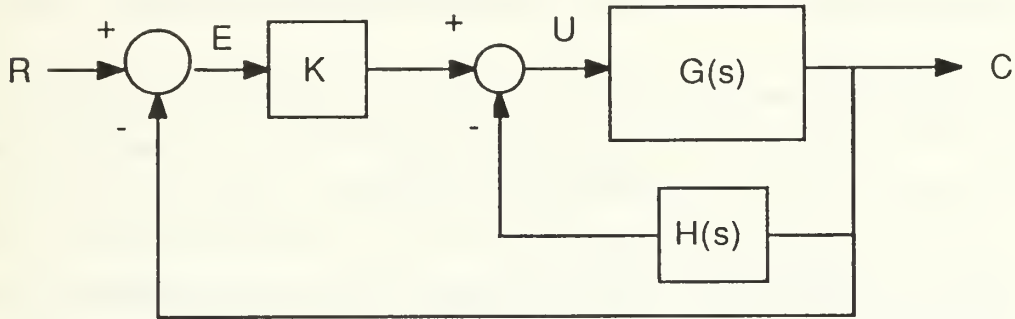

Figure 2. Feedback control arrangement: Unity feedback is preserved.

Consider an all pole plant in the general form

$$G(s) = \frac{K}{s^n + A_{n-1}s^{n-1} + A_{n-2}s^{n-2} + \dots + A_1s + A_0} \quad (2.1)$$

Using full state feedback, the feedback transfer function is

$$H(s) = k_{n-1}s^{n-1} + \dots + k_1s + k_0 \quad (2.2)$$

Then the characteristic equation is

$$1 + G(s)H(s) = 0 \quad (2.3)$$

$$s^n + (A_{n-1} + Kk_{n-1})s^{n-1} + \dots + (A_1 + Kk_1)s + (A_0 + Kk_0) = 0 \quad (2.4)$$

Since the roots of the characteristic polynomial are a function of the polynomial's coefficients, it is obvious that every root of the system can be located by adjusting the feedback coefficients. In doing this, the systems transient response is changed. There

are many methods which can be used to adjust the feedback gains of these systems. However, cost functions and function minimization will be used here.

When one considers the use of cost functions in system design, this use can be thought of as a way of finding the best possible combination of system parameter values to minimize the value of the integral. It must be noted that the use of cost functions in system design does not guarantee that the design will meet specifications. However, by minimizing the value of a given cost function, the best value for each coefficient in the characteristic polynomial is specified. This in turn defines the locations or pattern for the characteristic roots.

The characteristic root pattern for many design methods have been categorized into standard forms for the characteristic equation. Some of the more common standard forms have been used quite extensively in system design. They include the Binomial form, Butterworth form, and the Integral of time times absolute error form to name a few. Examples of these standard forms are shown in Fig. 3. These forms define the desired characteristic equations. State variable feedback can be used to obtain the required coefficients.

Table III. The Binomial Standard Forms

$$\begin{aligned}
 & s + \omega \\
 & s^2 + 2\omega s + \omega^2 \\
 & s^3 + 3\omega s^2 + 3\omega^2 s + \omega^3 \\
 & s^4 + 4\omega s^3 + 6\omega^2 s^2 + 4\omega^3 s + \omega^4 \\
 & s^5 + 5\omega s^4 + 10\omega^2 s^3 + 10\omega^3 s^2 + 5\omega^4 s + \omega^5 \\
 & s^6 + 6\omega s^5 + 15\omega^2 s^4 + 20\omega^3 s^3 + 15\omega^4 s^2 + 6\omega^5 s + \omega^6 \\
 & s^7 + 7\omega s^6 + 21\omega^2 s^5 + 35\omega^3 s^4 + 35\omega^4 s^3 + 21\omega^5 s^2 + 7\omega^6 s + \omega^7 \\
 & s^8 + 8\omega s^7 + 28\omega^2 s^6 + 56\omega^3 s^5 + 70\omega^4 s^4 + 56\omega^5 s^3 + 28\omega^6 s^2 + 8\omega^7 s + \omega^8
 \end{aligned}$$

Table IV. The Butterworth Standard Forms

$$\begin{aligned}
 & s + \omega \\
 & s^2 + 1.414\omega s + \omega^2 \\
 & s^3 + 2.0\omega s^2 + 2.0\omega^2 s + \omega^3 \\
 & s^4 + 2.0\omega s^3 + 3.464\omega^2 s^2 + 2.0\omega^3 s + \omega^4 \\
 & s^5 + 3.211\omega s^4 + 5.211\omega^2 s^3 + 5.211\omega^3 s^2 + 3.211\omega^4 s + \omega^5 \\
 & s^6 + 3.801\omega s^5 + 7.416\omega^2 s^4 + 0.13\omega^3 s^3 + 7.40\omega^4 s^2 + 3.801\omega^5 s + \omega^6 \\
 & s^7 + 4.5\omega s^6 + 10.1\omega^2 s^5 + 11.0\omega^3 s^4 + 11.0\omega^4 s^3 + 10.1\omega^5 s^2 + 4.5\omega^6 s + \omega^7 \\
 & s^8 + 5.12\omega s^7 + 13.11\omega^2 s^6 + 21.81\omega^3 s^5 + 25.00\omega^4 s^4 + 21.81\omega^5 s^3 + 13.11\omega^6 s^2 + 5.12\omega^7 s + \omega^8
 \end{aligned}$$

Table V. The Minimum ITAE Standard Forms, Zero-Displacement-Error Systems

$$\begin{aligned}
 & s + \omega \\
 & s^2 + 1.4\omega s + \omega^2 \\
 & s^3 + 1.75\omega s^2 + 2.15\omega^2 s + \omega^3 \\
 & s^4 + 2.1\omega s^3 + 3.4\omega^2 s^2 + 2.7\omega^3 s + \omega^4 \\
 & s^5 + 2.8\omega s^4 + 5.0\omega^2 s^3 + 5.5\omega^3 s^2 + 3.4\omega^4 s + \omega^5 \\
 & s^6 + 3.25\omega s^5 + 0.60\omega^2 s^4 + 8.00\omega^3 s^3 + 7.45\omega^4 s^2 + 3.95\omega^5 s + \omega^6 \\
 & s^7 + 4.475\omega s^6 + 10.42\omega^2 s^5 + 15.08\omega^3 s^4 + 15.51\omega^4 s^3 + 10.61\omega^5 s^2 + 4.58\omega^6 s + \omega^7 \\
 & s^8 + 5.20\omega s^7 + 12.80\omega^2 s^6 + 21.60\omega^3 s^5 + 25.75\omega^4 s^4 + 22.20\omega^5 s^3 + 13.30\omega^6 s^2 + 5.15\omega^7 s + \omega^8
 \end{aligned}$$

Figure 3. Common characteristic equation standard forms: (From Ref. 1.)

The cost functions considered in this study are

$$J = \int_0^{\infty} E^2 dt \quad (2.5)$$

and

$$J = \int_0^{\infty} (E^2 + QU^2) dt \quad (2.6)$$

where E is the system error, U is the control effort, Q is a weighting factor chosen by the designer based on the relative importance of E and U in the specific application.

Algebraic evaluation of these integrals is a labor intensive procedure even for lower order systems. For higher order systems, the number of variables is further increased and algebraic evaluation of these integrals is a near impossibility. Evaluation of these and other cost functions can be completed readily by using computer simulation and function minimization. This method of cost function evaluation is straight forward. The scheme is shown in Fig. 4.

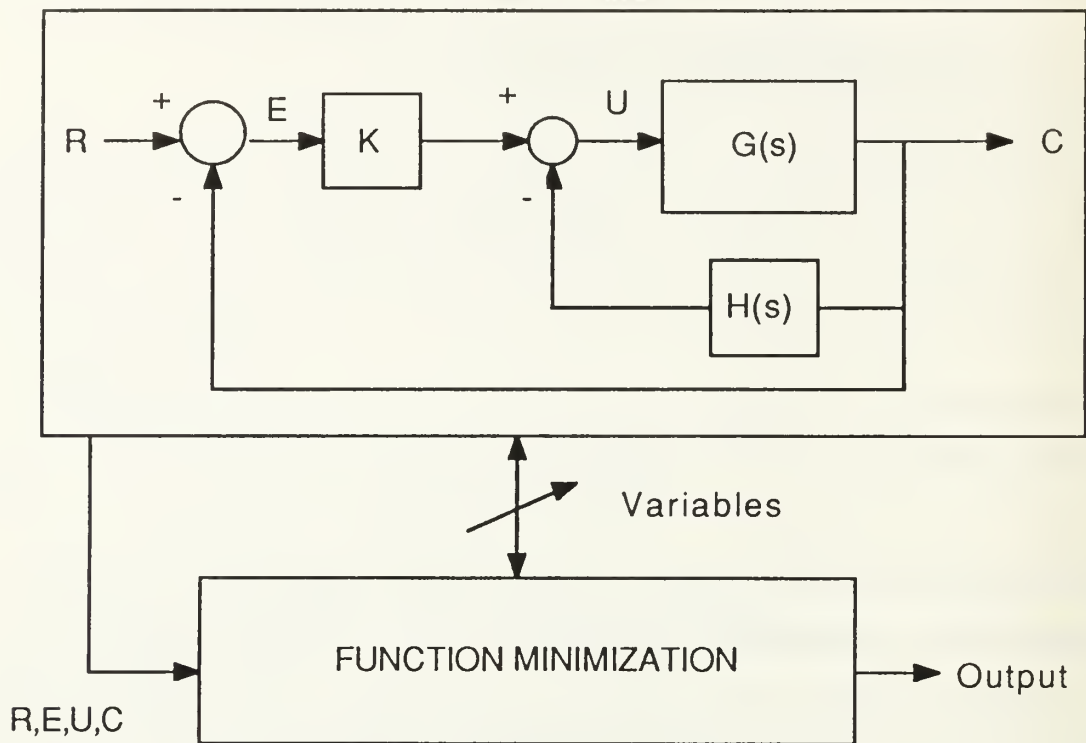

Figure 4. Implementation of function minimization: (From Ref. 1.)

Dynamic Simulation Language, DSL, was used to implement this design method. This method works by using a program and a subroutine. The system to be simulated is implemented in the program and variables are passed to the subroutine where the cost function is evaluated. This process is repeated iteratively until the cost function is minimized. The operator must give initial values to start this procedure. While this method of system design is quite useful, one must be aware of constraints that its use places on the problem. It must be pointed out that the integral cannot be evaluated for an infinite period of time. Hence, a final time must be picked for the simulation. This does not present a real problem for the evaluation of the integral. One must simply understand that error will exist in the solution. The amount of error in the solution due to simulation time is a function of the plant under study and how much CPU time is available. For most control systems, CPU time is not a problem. However, a compromise can usually be reached between CPU time and solution accuracy such that the error is insignificant.

Additionally, in using this approach the parameters which are to be optimized must be independent and initial values for these parameters must be established. These initial values must be picked such that the initial system is stable. If the initial system response is not stable, the minimization routine may not converge. Prudent choices for initial values will usually satisfy this criteria without difficulty. Other advantages of function minimization are

1. Nonlinear cost functions can be evaluated.
2. The nonlinear characteristics of the system are easily implemented in the simulation.
3. Limitations such as amplifier saturation can be included in the simulation.
4. Nonlinear compensators can be used and their parameters adjusted by the function minimization subroutine.

By using function minimization a minimum, if desired, can be found for most cost functions. Even though some systems designed using this method will not be optimal, they will be the best system available given the allowable parameter adjustments. [Ref. 1]

A. PLANT DEFINITIONS

In an attempt to study systems which are some what complex, third and fourth order plants are considered. Second order plants are not considered because treatment of these systems is quite common in design literature. Type one systems are used because they give no steady state error to a unit step input.

One of the problems which comes to light in a study of this nature is that for the systems which are to be studied, how can the data be generated so that it can be compared equitably? That is to say, how can a comparison of *apples and oranges* be avoided? In order to establish a common starting point, each of the plants are initially placed at the limit of stability. This forward gain value is decreased slightly if necessary in order to ensure that the function minimization subroutine will converge.

1. PLANT 1

The plant transfer function is

$$G(s) = \frac{K}{s(s+2)(s+6)} \quad (2.7)$$

Since we desire that the value of K be such that the plant is at the stability limit, the characteristic equation must be determined and the value of K found. The closed loop transfer function is

$$G_{eq}(s) = \frac{G(s)}{1 + G(s)H(s)} \quad (2.8)$$

and since unity feedback is used

$$H(s) = 1 \quad (2.9)$$

Therefore the characteristic equation is

$$1 + G(s)H(s) = 0 \quad (2.10)$$

$$1 + \frac{K}{s(s+2)(s+6)} = 0 \quad (2.11)$$

$$s^3 + 8s^2 + 12s + K = 0 \quad (2.12)$$

To determine the required value for K substitute $s = j\omega$ into the characteristic equation to obtain

$$-j\omega^3 - 8\omega^2 + 12j\omega + K = 0 \quad (2.13)$$

Separating the imaginary parts of this equation and solving for ω

$$-\omega^3 + 12\omega = 0 \quad (2.14)$$

and

$$\omega = \pm 3.464 \quad (2.15)$$

Substituting this value of ω into the remaining real part of equation (2.13)

$$-8(3.464)^2 + K = 0 \quad (2.16)$$

and

$$K = 96 \quad (2.17)$$

The final plant transfer function is

$$G(s) = \frac{96}{s(s+2)(s+6)} \quad (2.18)$$

The unit step response is shown in Fig. 5. This plant is clearly at the stability limit. The reason for testing the plant at this point serves two purposes. First, it verifies the calculations made so far, and second, it validates the computer simulation program.

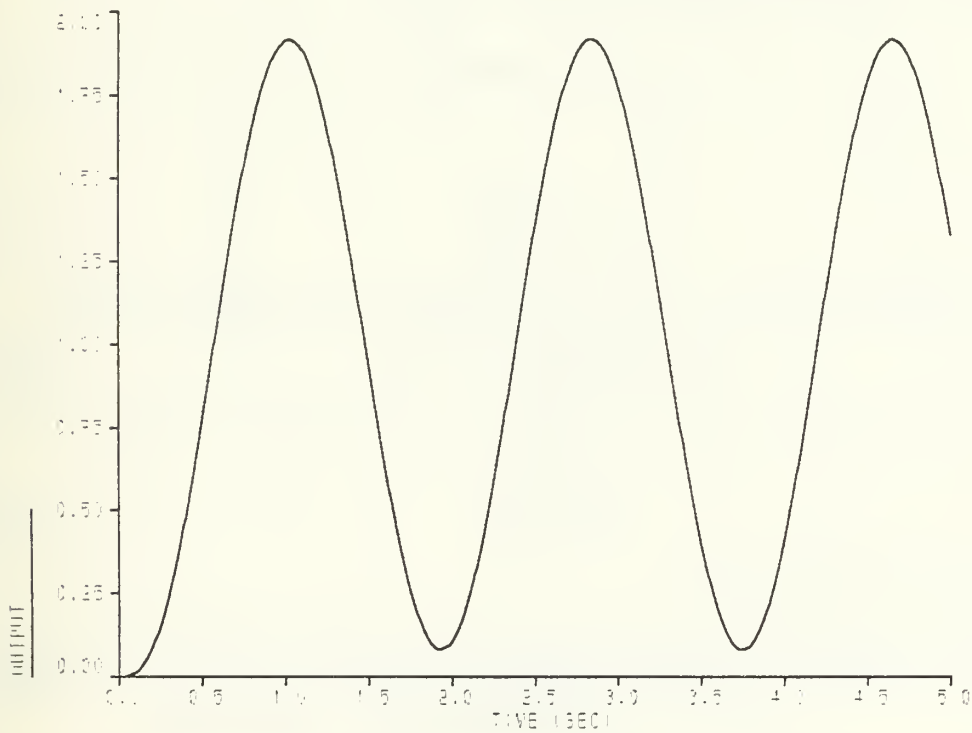

Figure 5. Third order system: Unit step response before cost function is minimized. Characteristic roots are located at $s = \pm j 3.464$.

2. PLANT 2

The plant transfer function is

$$G(s) = \frac{K}{s(s+2)(s+6)(s+9)} \quad (2.19)$$

Repeating the procedure used for plant 1, the characteristic equation is

$$1 + \frac{K}{s(s+2)(s+6)(s+9)} = 0 \quad (2.20)$$

$$s^4 + 17s^3 + 84s^2 + 108s + K = 0 \quad (2.21)$$

Substituting $s = j\omega$ and separating the imaginary portion

$$-17\omega^3 + 108\omega = 0 \quad (2.22)$$

and

$$\omega = \pm 2.52 \quad (2.23)$$

Again substituting this value of ω into the remaining real part of equation (2.21)

$$(2.52)^4 - 84(2.52)^2 + K = 0 \quad (2.24)$$

and

$$K = 493.1 \quad (2.25)$$

The final plant transfer function is

$$G(s) = \frac{493.1}{s(s+2)(s+6)(s+9)} \quad (2.26)$$

The unit step response and closed loop root locations for this plant are shown in Fig.6. The reason for using this method to determine the value of K to place the system at the stability limit is two fold. First, it gives the gain value required, and second, it gives the value of ω where the $j\omega$ axis is crossed. Again, it is obvious that this system is at the stability limit. The results obtained from simulating the system agree with calculations. Hence, as explained earlier, the calculations and the simulation program are validated.

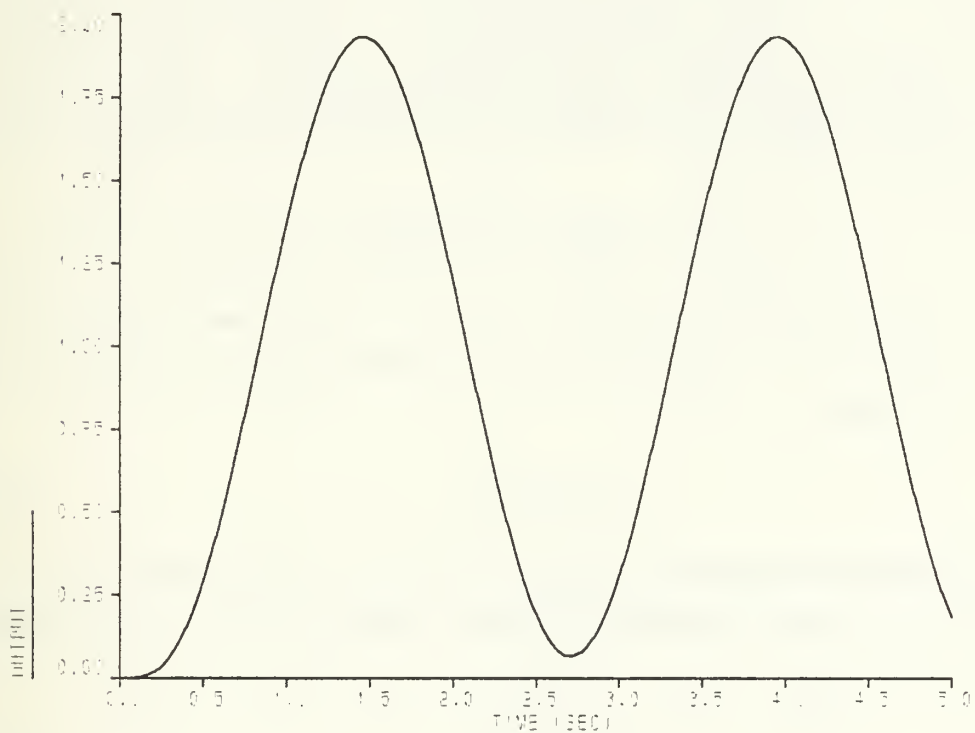

Figure 6. Fourth order system: Unit step response before plant is minimized. Characteristic roots are located at $s = \pm j 2.52$.

III. THE INTEGRAL OF ERROR SQUARED

If full state feedback is used to compensate the system, all coefficients of the characteristic equation become variable and a minimum of the integral of error squared exists only at $\omega = \infty$. To obtain a finite optimization the physical nature of the system requires that a constraint be placed on the bandwidth of the system. This is defined by specifying that the coefficient of the s^0 term in the characteristic equation should be ω_0^N where N is the order of the system.

For this study, the specified systems are constrained so that ω_0 is equal to 20 rad/sec. This value was chosen as a matter of convenience. In order to do this one simply must keep in mind the relationship between the feedback gain k_0 and the plant forward gain value k_v for the equivalent system. Mathematically, this relationship for the third order system is

$$(k_0 k_v)^3 = \omega_0^3 \quad (3.0)$$

Because it is desired that the system frequency be 20 rad/sec, and the forward gain value k_v is equal to 96, one simply substitutes the known values and solves for the required value for k_0

$$96k_0 = 8000 \quad (3.1)$$

$$k_0 = 83.333 \quad (3.2)$$

Repeating this procedure for the fourth order system we obtain

$$(k_0 k_v)^4 = \omega_0^4 \quad (3.3)$$

$$493.1k_0 = 160000 \quad (3.4)$$

$$k_0 = 324.477 \quad (3.5)$$

This common value of ω_0 is not chosen so that the third and fourth order systems can be compared. The two systems cannot be compared, and an attempt to do so would be like comparing apples and oranges. This value is used to help standardize each system while under study.

A. THIRD ORDER SYSTEM

Carrying out the minimization procedure described earlier, it is found that the system's unit step response is significantly improved. This response is shown in Fig. 7. In order to see how well cost function minimization works, the minimized response is compared to the unit step response obtained by implementing the standard form for the integral of error squared, IES. This response is also shown in Fig. 7. There is no difference in the unit step response for the two design methods. The fact that there is no steady state error is an expected result. In order to investigate the reasons for no difference in the response for the two design methods, the characteristic equations and roots for both designs are shown in Table 1.

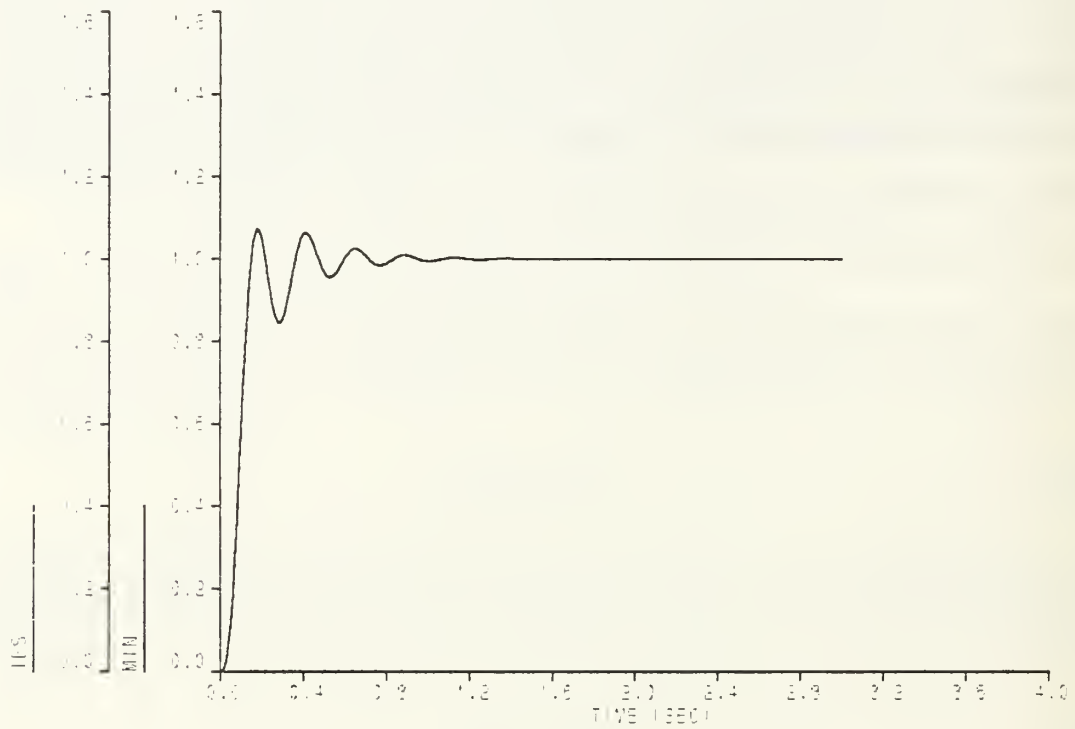

Figure 7. Third order system minimized response: Unit step response for minimized and IES standard form designs.

Table 1. CHARACTERISTIC EQUATIONS AND ROOTS

DESIGN	CHARACTERISTIC EQUATION	r_1	$r_{2,3}$
MINI-MIZED	$s^3 + 20s^2 + 800s + 8000 = 0$	-11.397	$-4.30 \pm j 26.14$
IES	$s^3 + 20s^2 + 800s + 8000 = 0$	-11.397	$-4.30 \pm j 26.14$

The results shown in Table 1 are expected since the systems unit step response are identical. Looking further into the results of the minimization process, an explanation is found that might further explain the similarities in the unit step response. During the minimization process initial guesses were made for the values of feedback gains required to minimize the cost function. After execution of the program, the values of the feedback gains generated were iteratively placed in the minimization program. This process was repeated until the minimum was obtained. To see how well this worked, the final cost for the minimized and IES methods of design both equal 0.075. The simulation cost also equals 0.075. Each of the three values for cost is obtained by a different method. The minimization cost is the value determined from the function minimization program. The simulation cost is the value determined by placing the feedback gains generated in the function minimization program into a different simulation program. In this simulation program the cost function was again evaluated while generating the unit step response shown in Fig. 7. The integral of error squared cost value was also determined in the simulation program, but it is the cost determined from evaluation of the cost function for the standard form method of design. These values given for cost have no significance or real meaning. They simply represent the numerical value obtained from evaluation of the integral. Observing these cost, it is seen that the minimization and simulation cost are equal. The fact that they are equal serves to check the minimization and simulation programs for proper performance. The point is made by noting that the cost value for the IES method of design is equal to the cost for the minimization method of design.

B. FOURTH ORDER SYSTEM

The same basic steps carried out for the previous system are repeated for the fourth order system. It is understood that the actual results will not be the same, but the trends

should be continued. As pointed out earlier, the value of ω_0 for this system is constrained in order to control the system bandwidth. The value of k_0 which gives $\omega_0 = 20$ rad/sec was determined to be 324.477. Only the feedback gains k_1 , k_2 , and k_3 are allowed to be changed by the function minimization subroutine. Once the cost function is minimized and the final values for the feedback gains are determined, the minimized system is simulated and the unit step response obtained. This minimized system is again compared to a system designed by using the standard form for the integral of error squared. The unit step response for these two designs are shown in Fig. 8.

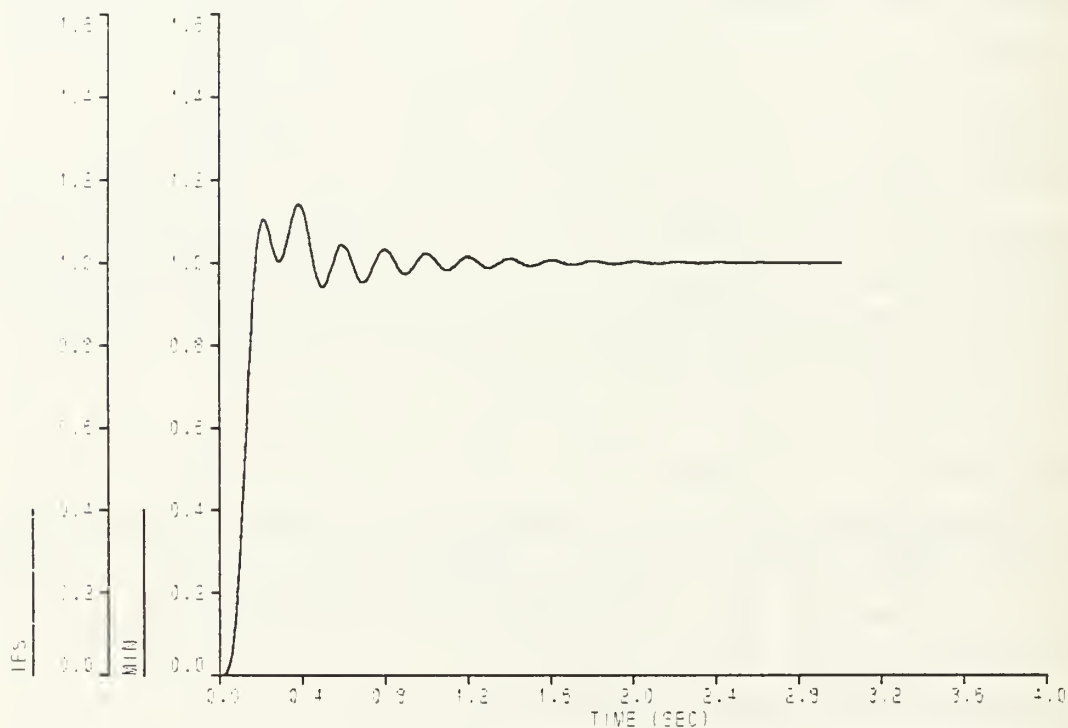

Figure 8. Fourth order system minimized response: Unit step response for minimized and IES standard form design.

Again, the unit step response for these two methods of design are identical. The characteristic equation and closed loop roots for each method of design are also identical;

$$s^4 + 20s^3 + 1200s^2 + 1600s + 160000 = 0 \quad (3.6)$$

Roots are located at $s = -2.10 \pm j 31.1$ and $s = -7.90 \pm j 10.14$. On examination of the cost for these two designs it is found that they are again equal, 0.100.

IV. WEIGHTING THE CONTROL EFFORT

In some practical applications, the number of adjustable parameters may be limited due to cost, weight, or space limitations. The design engineer must, taking these limitations into account, design the best possible system. As an example, if cascade compensation is used for the design, the compensator may be limited to one zero and one pole, where only the gain is adjustable. For higher order systems it may or may not be possible to determine an optimal system defined by a cost function such as

$$J = \int_0^t (E^2 + QU^2)dt \quad (4.0)$$

However, by using simulation and function minimization a minimum can be found for the cost function. It must be kept in mind that the system designed using this method will not be optimal, but will be the best available system given the parameters which are variable. This design may or may not meet specifications. [Ref. 1]

For the plants considered in this case study, how does the cost function affect the closed loop root locations? Does its use enhance or degrade system performance? Where do the closed loop roots of the characteristic equation tend as the weighting factor, Q , is changed? Specifically, Chang [Ref. 2] points out that as the weighting factor is decreased, the roots of the characteristic equation should tend to a Butterworth pattern. Shown in Fig. 9 is the Butterworth configuration for the characteristic roots. It is seen that the characteristic roots are equally spaced along the circumference of a circle whose radius is equal to ω_0 .

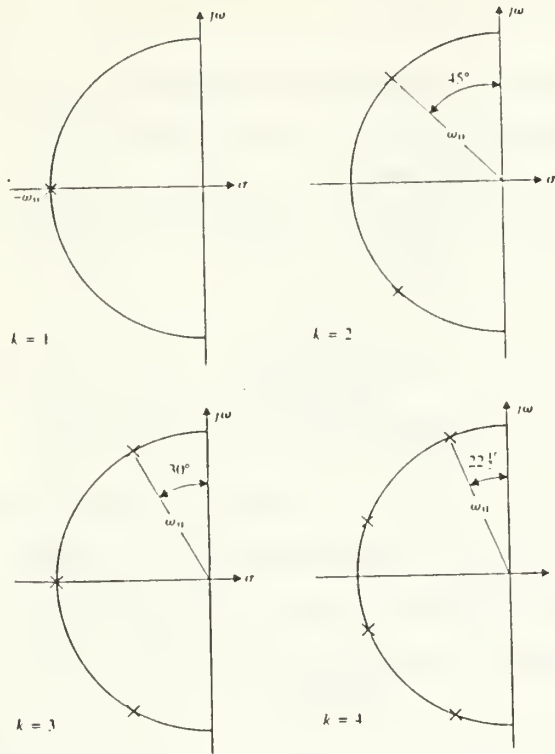

Figure 9. Butterworth pattern of characteristic roots: Here k is the system order. (From Ref 3.)

A. PLANT 1

The open loop transfer function for this plant is given as

$$G(s) = \frac{96}{s(s+2)(s+6)} \quad (4.1)$$

This system is implemented using the simulation and function minimization method introduced earlier. In this case the cost function is changed. Three basic steps are used to study this cost function. First, the system is simulated and the cost function is minimized with specific weights placed on the control effort, U . Second, the minimized systems' closed loop roots are determined and tabulated. Finally, the systems' unit step response is obtained. This procedure is repeated with different weights placed on the control effort.

Because the cost function will affect a given plant in a unique manner, there is no way of knowing if the system designed as a result of minimizing the cost function will

meet specifications. Further, because there is no method to determine how to choose values for the weighting factor, Q , it is normally chosen arbitrarily. However, since it is known that, as the weighting factor is decreased, the characteristic roots should tend to a Butterworth pattern, the symmetric root locus is used to help make an educated guess for the proper value of the weighting factor, Q .

For this system the symmetric root locus is determined by placing the characteristic equation in the form

$$G(s)G(-s) = \frac{K^2}{Q^2} \frac{1}{(s)(-s)(s+2)(s-2)(s+6)(s-6)} \quad (4.2)$$

This symmetric root locus, shown in Fig. 10, was generated using the computer program EWALD. The symmetric root locus for this third order system shows how the root locations radiate outward and tend asymptotically towards the Butterworth configuration. The process of minimizing the cost function for various values of Q causes the roots of the characteristic equation to move outward along the locus to a specific value of ω_0 . For each chosen value of Q , the minimum reached forces the characteristic roots into a closer approximation to the Butterworth pattern. It must be pointed out that as Q is decreased and the cost function is minimized, the value of ω_0 is increased.

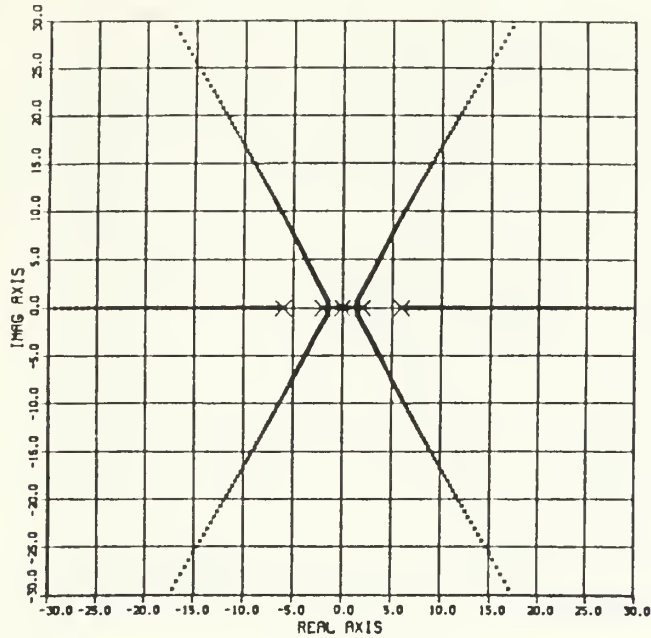

Figure 10. Symmetric root locus for third order system: Used to assist finding values for weighting factor, Q .

Using this procedure, the true Butterworth pattern is reached only when $\omega_0 = \infty$. Shown in Fig.11 is the symmetric root locus with minimization results plotted. It is shown that the closed loop roots tend to a circular pattern. One of the unique features found during the minimization process was that for some values of the weighting factor, the characteristic roots did not plot on the symmetric root locus as expected. Efforts to determine why this happened were inconclusive. However, this behavior may be attributed to reaching a local minimum during the minimization process.

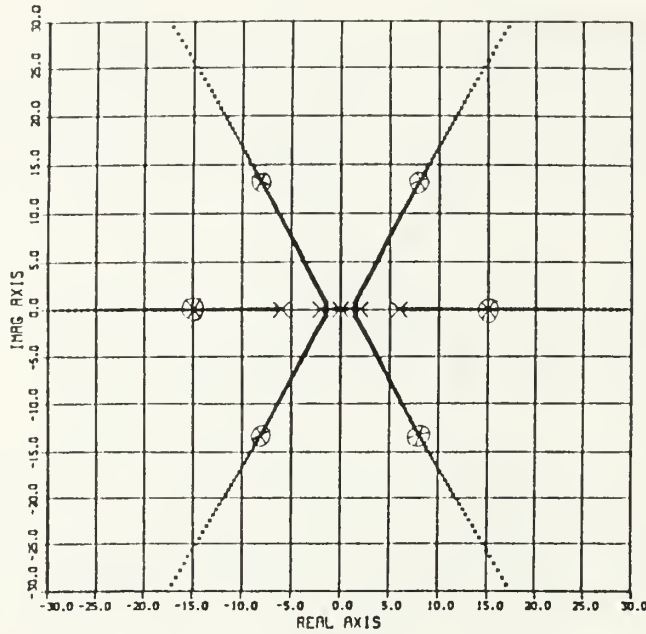

Figure 11. Third order system minimization results: Characteristic root locations plotted on symmetric root locus shows root movement towards Butterworth pattern.

Since the system characteristic roots are expected to tend towards a Butterworth pattern, the unit step response for the true Butterworth configuration is determined and compared to the minimization results. The true Butterworth unit step response was obtained by using the standard form for the third order system. This standard form was implemented using the same value of ω_0 as those determined from minimizing the subject cost function. The Butterworth standard form for the third order system is

$$s^3 + 2\omega_0 s^2 + 2\omega_0^2 s + \omega_0^3 \quad (4.3)$$

The form of the system open loop transfer function is

$$G(s) = \frac{\omega_0^3}{s^3 + 2\omega_0 s^2 + 2\omega_0^2 s} \quad (4.4)$$

The system was simulated using ω_0 equal to 15.96, 17.12, and 26.72 rad/sec. As pointed out earlier, it is desired to make as true a comparison as possible. Therefore, frequency, time of simulation, and system type are the same. Figure 12 shows the results for each design when the weighting factor is equal to 0.0005. This establishes ω_0 at 15.96 rad/sec. Comparing the minimized results to the standard form results it is seen that the systems' unit step response are identical. Table 2 shows the characteristic equation and closed loop roots for $Q = 0.0005$.

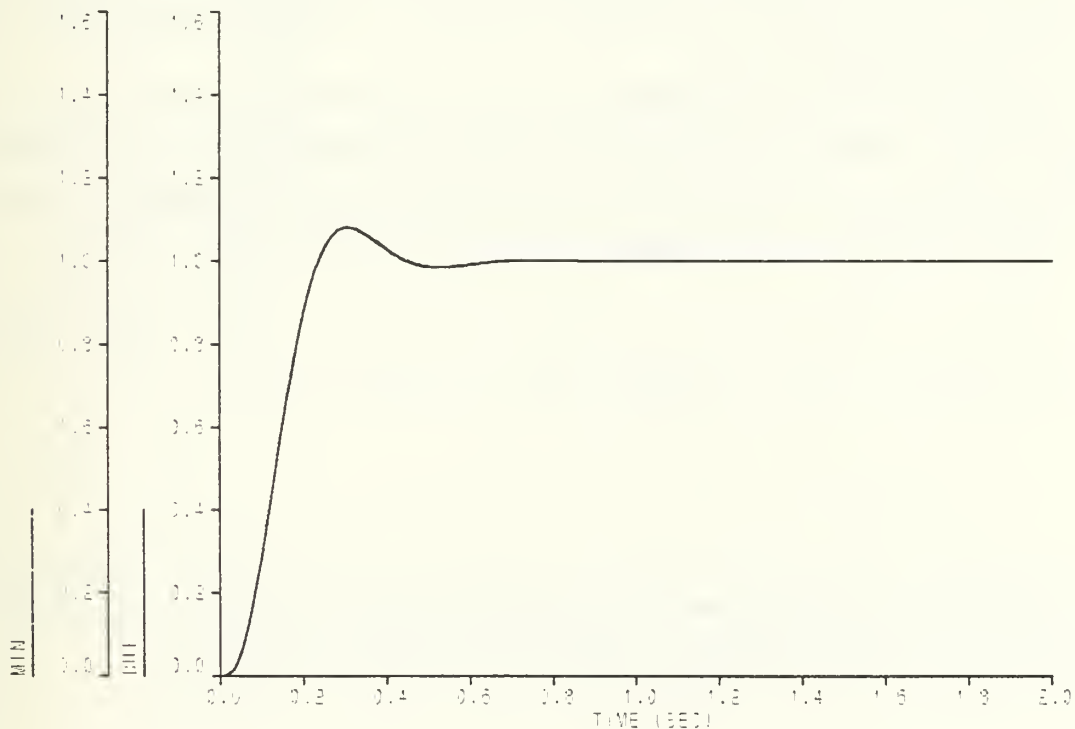

Figure 12. Third order system minimized unit step response: Comparison of Butterworth standard form design and minimized design, $Q = 0.0005$.

Table 2. THIRD ORDER SYSTEM DESIGN SUMMARY $Q = 0.0005$

METHOD	CHARACTERISTIC EQUATION	r_1	$r_{2,3}$
BUTTERWORTH	$s^3 + 31.98s^2 + 514.74s + 4124 = 0$	-15.92	$-8.03 \pm j13.95$
MINIMIZED	$s^3 + 31.92s^2 + 509.57s + 4066.9 = 0$	-15.96	$-7.98 \pm j 13.82$

As expected, it is shown that the characteristic equation and roots are essentially the same. Further investigation of these designs show that the cost incurred by minimizing the cost function is 0.104 for the Butterworth design and 0.125 for the minimized design. Only the integral of error squared was evaluated for the Butterworth design. The subject cost function was evaluated for the minimized response. This explains the difference in the two values obtained for cost.

The second value of the weighting factor for which the subject cost function was minimized is $Q = 0.0002$. Shown in Fig. 13 is the unit step response for each method of design. Again, it can be seen that the response for the two design methods are fairly close. Table 3 shows the characteristic equations and closed loop root locations.

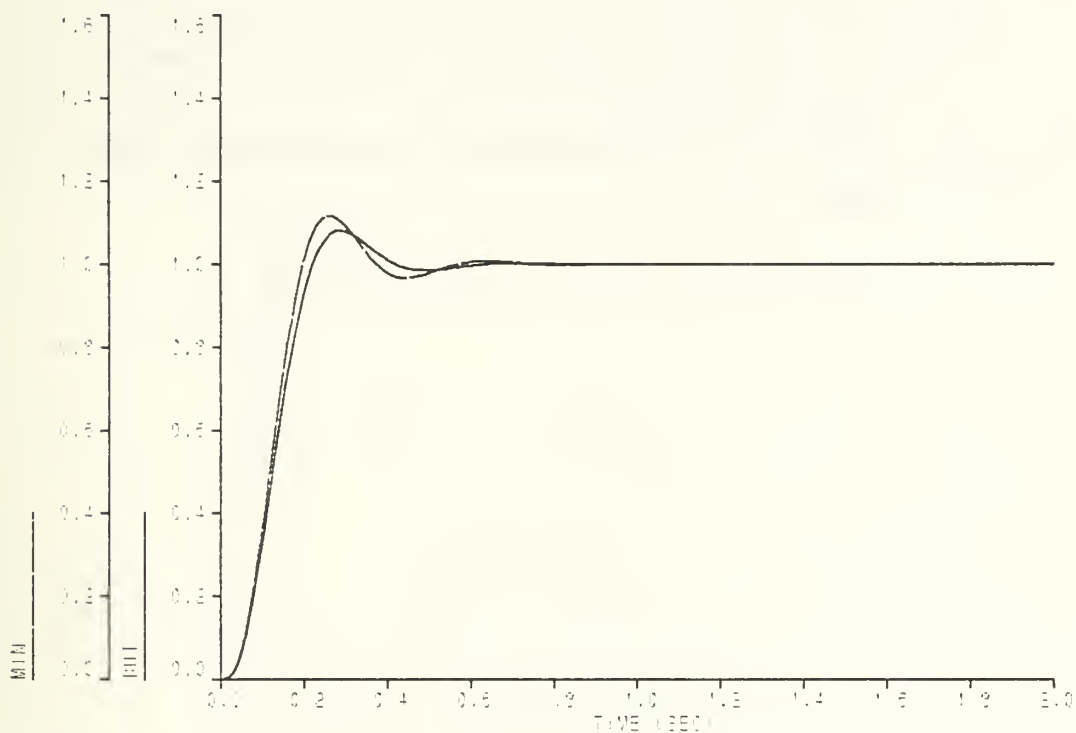

Figure 13. Third order system minimized unit step response: Comparison of Butterworth standard form design and minimized design, $Q = 0.0002$.

Table 3. THIRD ORDER SYSTEM DESIGN SUMMARY $Q = 0.0002$

METHOD	CHARACTERISTIC EQUATION	r_1	$r_{2,3}$
BUTTERWORTH	$s^3 + 34.24s^2 + 586.19s + 5017.8 = 0$	-17.12	$-8.56 \pm j 14.83$
MINIMIZED	$s^3 + 30.92s^2 + 564s + 5271 = 0$	-16.19	$-7.36 \pm j 16.47$

Again, as expected the characteristic equations and closed loop root locations are very close. Clearly, the trend established earlier is continued. Investigating the value of the cost function, it is found that the cost equals 0.0574 for the Butterworth design and 0.169 for the function minimization design.

Repeating this process for the third and final value of the weighting factor, $Q = 0.000005$, similar results were obtained. Figure 14 shows the unit step response for these two design methods. Observing these results, it is seen that there is significantly more overshoot in the minimized design response for this case. Also, the minimized response is slightly faster. Table 4 shows the characteristic equations and closed loop root locations for these designs.

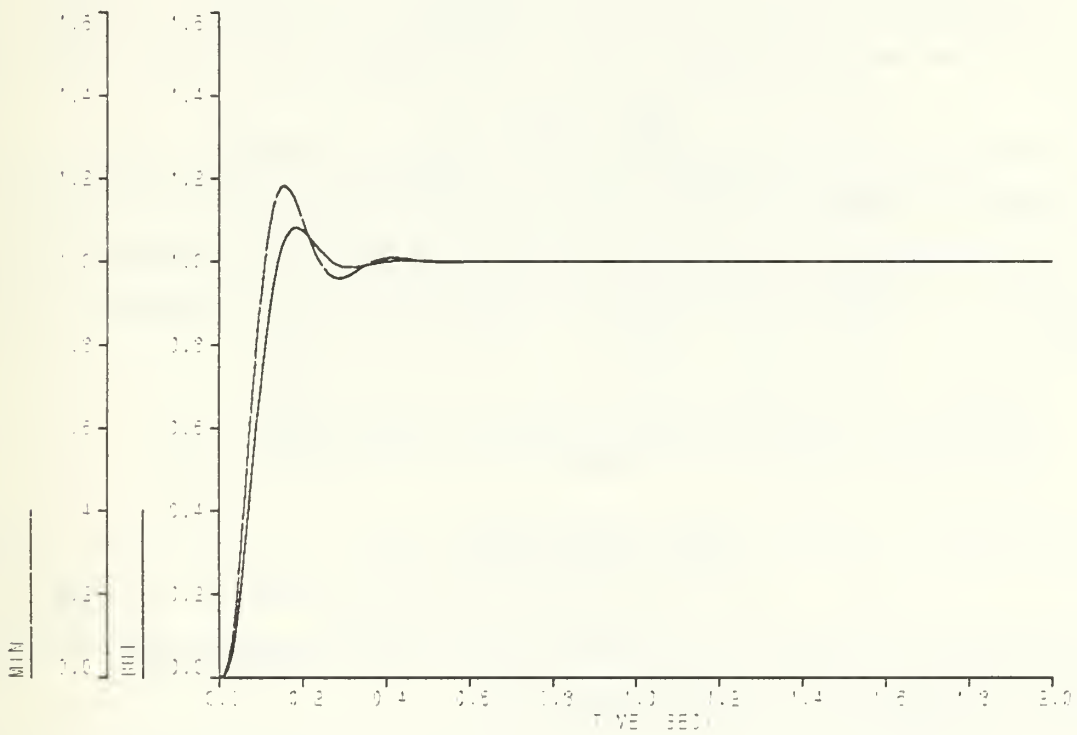

Figure 14. Third order system minimized unit step response: Comparison of Butterworth standard form design and minimized design, $Q = 0.000005$.

Table 4. THIRD ORDER SYSTEM DESIGN SUMMARY $Q = 0.000005$

METHOD	CHARACTERISTIC EQUATION	r_1	$r_{2,3}$
BUTTERWORTH	$s^3 + 53.44s^2 + 1427.92s + 19076.97 = 0$	-26.72	$-13.36 \pm j$ 23.14
MINIMIZED	$s^3 + 69.75s^2 + 1779.9s + 33000.64 = 0$	-46.78	$-11.48 \pm j$ 23.95

Observing the characteristic equations and closed loop roots for this case, it is seen that significant differences exists. These differences are responsible for the differences in the unit step response for the two design methods for this case. The values of the cost functions are 0.062 for the Butterworth design and 0.060 for the minimization design method.

B. PLANT 2

Repeated here is the transfer function for the fourth order system.

$$G(s) = \frac{493.1}{s(s+2)(s+6)(s+9)} \quad (4.5)$$

The same basic steps carried out for the third order system are again completed for this system. The symmetric root locus is realized from

$$G(s)G(-s) = \frac{\frac{K^2}{Q^2}}{(s)(-s)(s+2)(s-2)(s+6)(s-6)(s+9)(s-9)} \quad (4.6)$$

Figure 15 shows the symmetric root locus for this system.

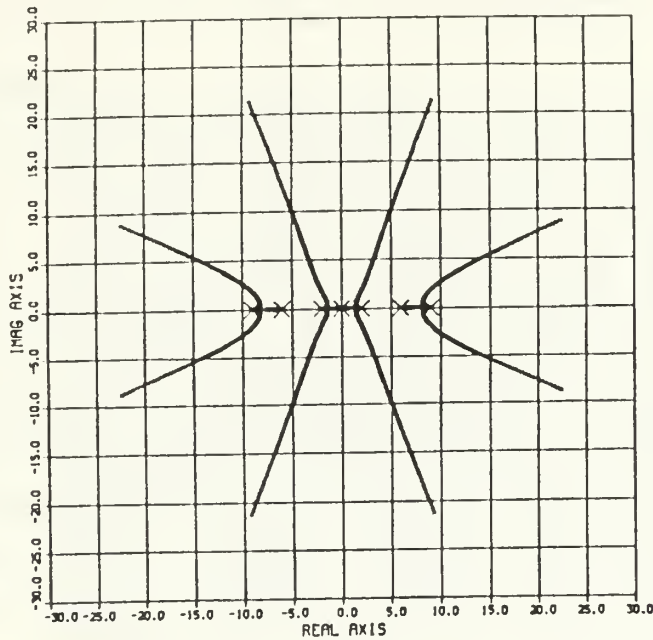

Figure 15. Symmetric root locus fourth order system: Used to assist in determining values for weighting factor, Q .

Again, the characteristic roots of this system move outward asymptotically towards a Butterworth configuration as the forward gain constant is increased by decreasing Q . As the cost function is minimized when Q is decreased, the Butterworth configuration is achieved as ω_0 approaches infinity. For this case study ω_0 approaching infinity is the result of very light weighting on the control effort, U . One can obtain the Butterworth pattern for small values of ω_0 by using pole placement.

The results for the minimized system are shown in Fig. 16. As the control effort is decreased, the closed loop roots move outward along the root locus. Even though the closed loop root locations shown in Fig. 16 do not form a true Butterworth pattern, the roots do tend towards a very rough circular pattern. It must be pointed out that the process of minimizing the cost function is very tedious. Simply because a minimum is reached does not guarantee that the root locations will match the symmetric root locus when plotted. Numerous values of Q were chosen and the system was minimized, but

all points did not match the root locus. An explanation for this behavior is not offered and is a subject for future study.

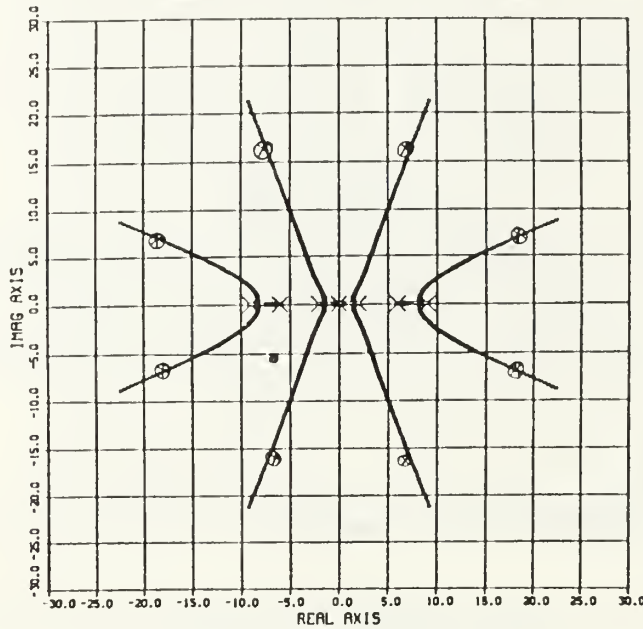

Figure 16. Fourth order system minimization results: Characteristic root locations plotted on symmetric root locus shows that roots do tend roughly to a circle.

In order to gain further insight into the results obtained by minimizing the cost function, the unit step response for the true Butterworth configuration is determined and the two are compared. The true Butterworth unit step response was obtained by using the standard form for the fourth order system. This standard form was implemented using the same values of ω_0 as those determined by minimizing the subject cost function. The Butterworth standard form for the fourth order system is

$$s^4 + 2.6\omega_0s^3 + 3.4\omega_0^2 + 2.6\omega_0^3s + \omega_0^4 \quad (4.7)$$

Since the subject plant is Type I, the system realized from the standard form is also Type I. The open loop plant transfer function is

$$G(s) = \frac{\omega_0^4}{s^4 + 2.6\omega_0 s^3 + 3.4\omega_0^2 s^2 + 2.6\omega_0^3 s} \quad (4.8)$$

This system was simulated using ω_0 equal to 11.15, 14.89, and 19.85 rad/sec.

In order to complete as true a comparison as possible all system parameters which could be made equal are so. That is to say, frequency, time of simulation, and system type are the same. The difference is the method in which these systems are designed. Figure 17 shows the results for each design when the weighting factor, Q, is equal to 0.001. This establishes an ω_0 equal to 11.15 rad/sec. Comparing these two systems it is evident that the system which was minimized with the weighting factor $Q = 0.001$ is a very close approximation to the Butterworth standard form. The transient portion of these two systems is essentially over in approximately 0.75 seconds. The maximum overshoot of the Butterworth standard form system is slightly higher than that of the minimized system. However, taking these minor differences into account, the Butterworth standard form and the minimized systems' step response are approximately the same.

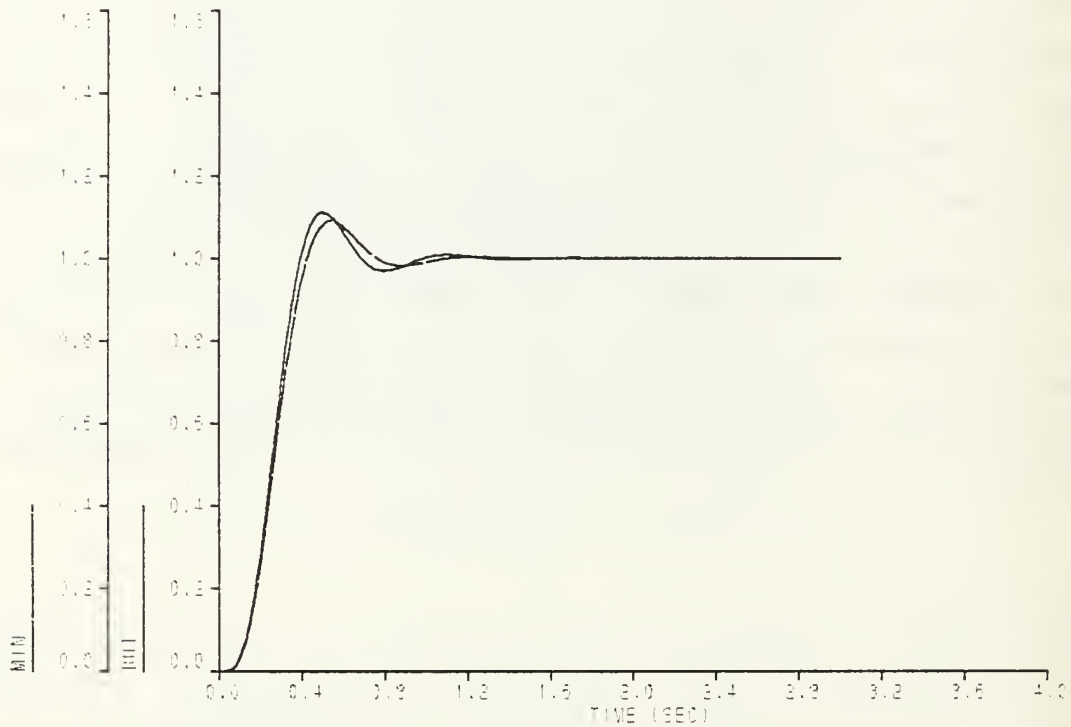

Figure 17. Fourth order system minimized unit step response: Unit step response for Butterworth standard form and minimized design.

Earlier in this study, it was pointed out that the design of linear systems is an exercise in positioning the roots of the characteristic equation. Even though this is not done here as a matter of procedure, this is precisely what is achieved by evaluating the cost function or using the standard form to realize a particular design. Where do the characteristic roots go for these systems? Table 5 shows the results for these systems.

Table 5. CHARACTERISTIC ROOT LOCATIONS $Q = 0.001$

METHOD	$r_{1,2}$	$r_{3,4}$
BUTTERWORTH	$-4.25 \pm j 10.31$	$-10.25 \pm j 4.39$
MINIMIZED	$-4.77 \pm j 9.13$	$-11.36 \pm j 4.08$

From Table 5 the root locations for the Butterworth design and the minimized design are nearly the same. This further explains the similarity in the unit step response for these two designs.

The second value of the weighting factor for which the subject cost function was minimized is $Q = 0.0001$. At this weighting, the frequency of the system was found to be 14.89 rad/sec. Again using the Butterworth standard form, the characteristic equation for this system is

$$s^4 + 38.714s^3 + 753.821s^2 + 8583.362s + 49156.255 = 0 \quad (4.9)$$

The characteristic equation which was determined from the minimization of the subject cost function is

$$s^4 + 41.35s^3 + 799.53s^2 + 8844.96s + 49054.96 = 0 \quad (4.10)$$

Note the values of the coefficients for the Butterworth characteristic equation, equation (4.9) and the minimized system characteristic equation, equation (4.10). The unit step response for these two designs are shown in Fig. 18. The same characteristics stated earlier for the previous design are again true with one exception. The systems overall response is faster, as expected, because of the increased value of ω_0 . Table 6 shows the characteristic root locations for these systems.

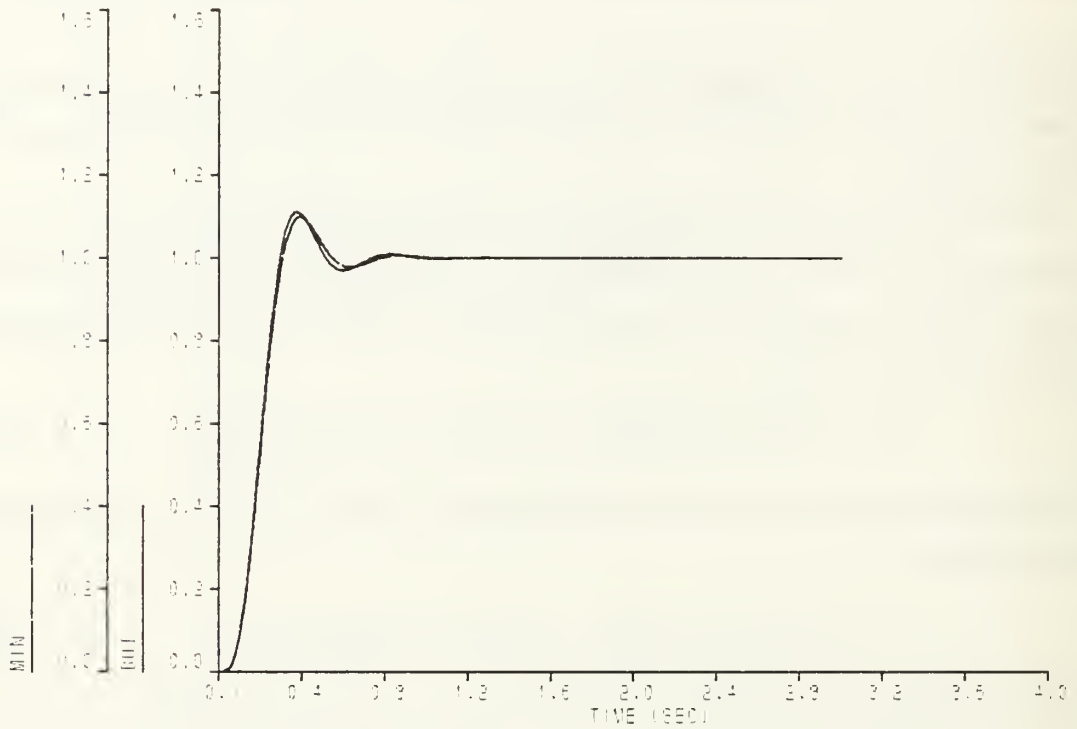

Figure 18. Unit step response minimized system: Butterworth and minimized systems unit step response weighting factor $Q = 0.0001$.

Table 6. CHARACTERISTIC ROOT LOCATIONS $Q = 0.0001$

METHOD	$r_{1,2}$	$r_{3,4}$
BUTTERWORTH	$-5.67 \pm j 13.77$	$-13.69 \pm j 5.86$
MINIMIZED	$-6.09 \pm j 12.85$	$-14.56 \pm j 5.52$

Again, the characteristic root locations for the Butterworth and the minimized designs are very close. This explains the similarity in the unit step response for these two systems.

The unit step response for the remaining weighting factor $Q = 0.00001$ is shown in Fig. 19. The trends established earlier are maintained and agree with expected results. Table 7 shows the characteristic root locations for these systems.

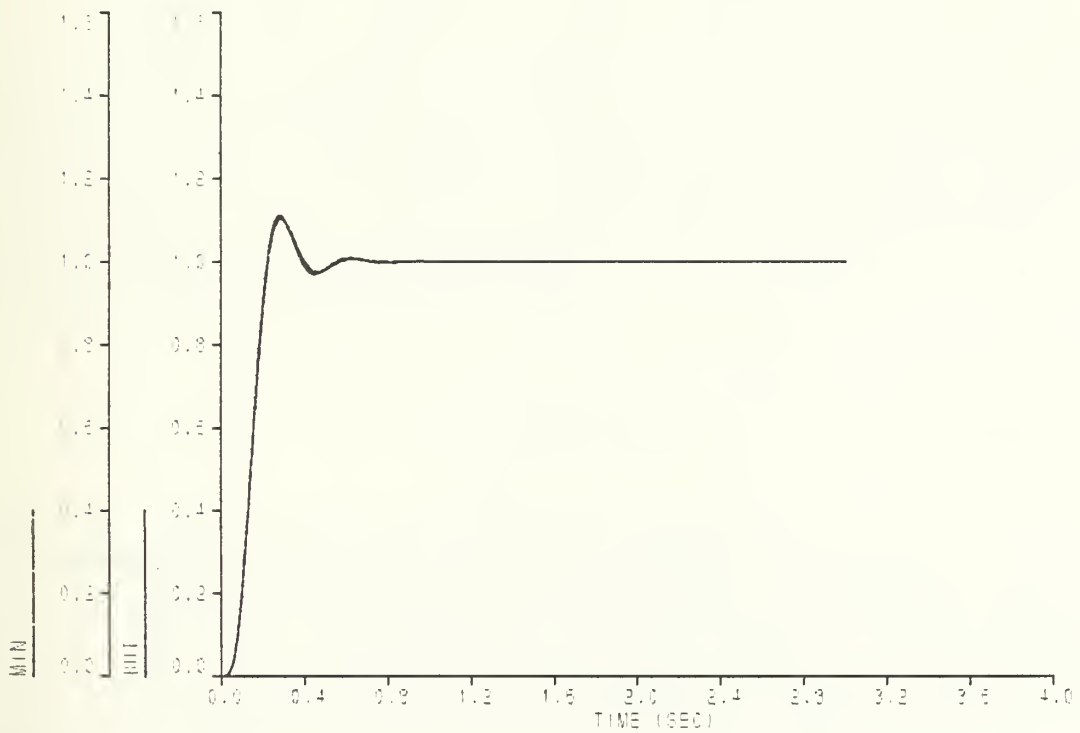

Figure 19. Fourth order minimized system: Butterworth, and minimized systems unit step response. Weighting factor $Q = 0.00001$.

Table 7. CHARACTERISTIC ROOT LOCATIONS $Q = 0.00001$

METHOD	$r_{1,2}$	$r_{3,4}$
BUTTERWORTH	$-7.56 \pm j 18.35$	$-18.25 \pm j 7.81$
MINIMIZED	$-8.05 \pm j 17.74$	$-18.31 \pm j 8.22$

Viewing the results shown in Table 7, it is obvious why the unit step response for these two design methods are in such close agreement. For all practical purposes, these results can be considered equal.

V. SYSTEM PERFORMANCE WITH SATURATION

For most practical linear control systems, there are limits on the linear operating range. These limits are usually given in the desired performance specifications for each system. In some cases, these limitations place severe constraints on the system to be designed, especially the dollar cost and physical weight of the desired system. In most cases, the size of the power source for the desired system will determine how well the system performs when pushed to extremes. How well a system performs when in saturation is of particular concern. Large inputs can be damaging to mechanical components for control systems. These inputs can cause electrical components to fail. For these reasons most control systems are designed such that they will saturate at lower input power levels. Friedland [Ref. 3] points out that the effect of occasional control saturation is usually not very serious, and systems which never saturate are probably over-designed. However, if the system almost always saturates it probably will not perform satisfactorily. Of course, bang-bang control systems are not included here. The cost function considered for saturation study is

$$J = \int_0^{\infty} (E^2 + QU^2)dt \quad (5.0)$$

A. MINIMIZED SYSTEM SATURATION RESPONSE

In order to determine the system performance in the presence of saturation a limiter is placed in the system as shown in Fig. 20. For this system, it is desired to limit the control effort. The procedure used to determine how well the system performs when in saturation is to note the unit step response for the system when the plant is not in saturation, just into saturation, and well into saturation. The limiter levels which give these results are not particularly important. It is desired to obtain the overall system performance.

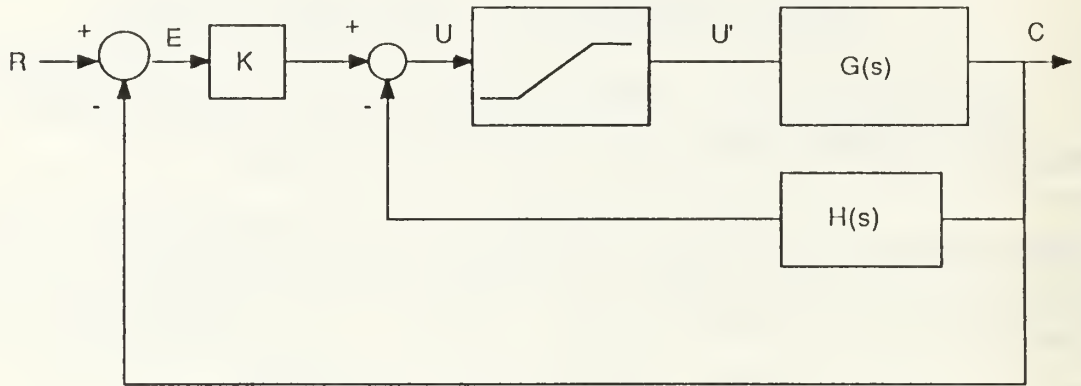

Figure 20. Saturation study system block diagram: Simulation method used to study system saturation performance.

1. Third order system

Figure 21 shows the unit step response for the minimized system when in saturation. Output MIN represents the system response without saturation. Output MINA represents the systems response with a small amount of saturation, and output MINB represents the system response when well into saturation. It is known that this or most other systems will not perform satisfactorily when allowed to saturate heavily. This system was placed far enough into saturation to illustrate how the system's performance begins to deteriorate. Clearly the system performs satisfactorily with a small amount of saturation, even though the response is slower. However, when the system is driven into heavy saturation the system's performance begins to deteriorate. Note the marked increase in the peak overshoot for this case. The system is beginning to go so far into saturation that it cannot respond to changes in the control input. To illustrate this point, Fig. 22 shows the output of the limiter.

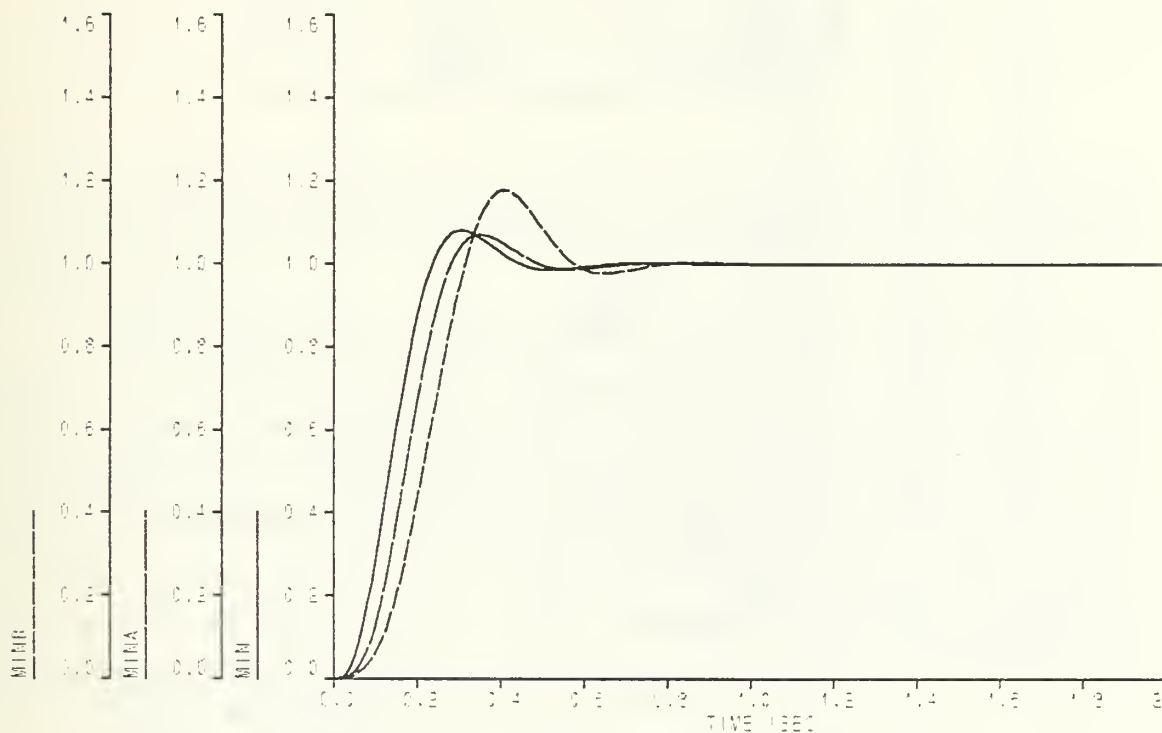

Figure 21. Third order system saturation step response: Outputs MIN, MINA, and MINB represent the system response with no saturation, mild saturation, and heavy saturation respectively.

Here U is the system control effort previously defined. LIMUA and LIMUB are limiter outputs for mild and heavy saturation respectively. These results indicate for mild saturation that the control effort is limited on the peak of the positive going portion of the control effort only, as seen in output LIMUA. When the system is driven into heavy saturation the control effort is limited on both the positive and the negative-going peaks. In each case where the system is allowed to saturate, the control effort to the system is less than the normal no-saturation value. Thus, when in saturation, the system receives power at a lower rate and cannot respond as fast as the unsaturated system.

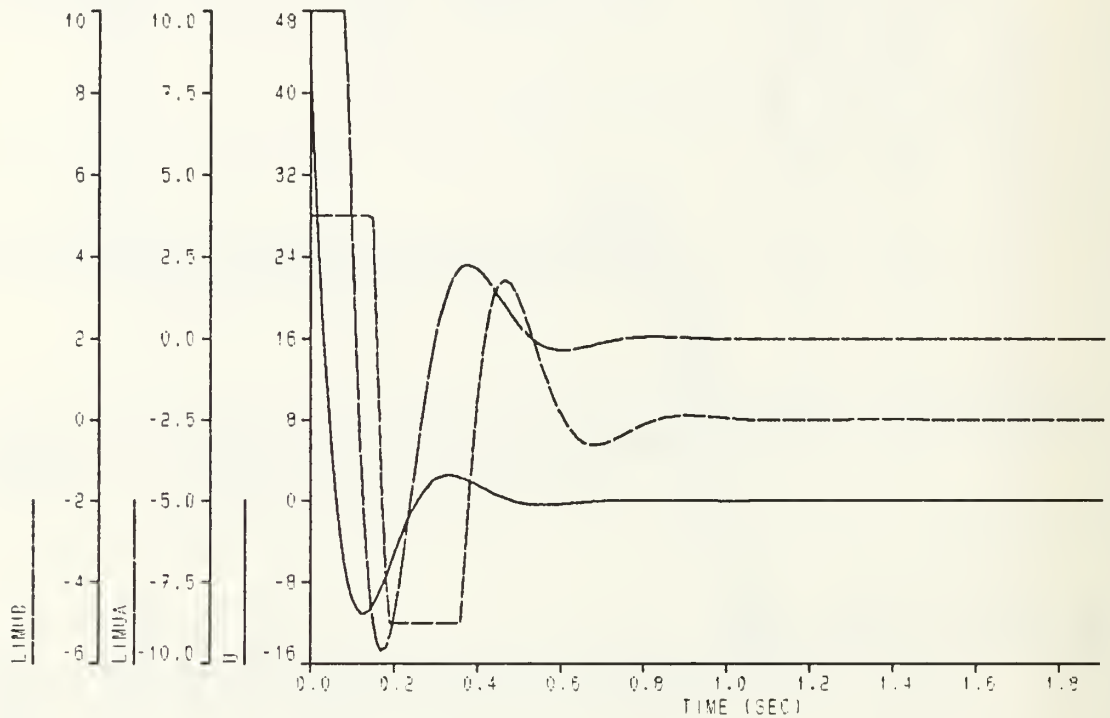

Figure 22. Third order system control effort changes: Variation of control effort, U and limiter output with mild saturation, LIMUA, and heavy saturation, LIMUB.

If minimizing the cost function, equation (5.0), is viewed as determining the area under the error and control effort curves, when the system is allowed to saturate this area increases. Hence, the cost of operating the system should increase. This point is verified by evaluating the cost function as the saturation level is increased. Shown in Table 8 are the results obtained.

Table 8. VALUE OF COST AT DIFFERENT SATURATION LEVELS

SATURATION LEVEL	COST
None	0.10386
Mild	0.13650
Heavy	0.17411

The results seen in Table 8 illustrate that the value of the cost function does increase as the saturation levels are increased. Hence, the area beneath the error and control effort curves is increased.

Chang [Ref. 2] proposed for the subject cost function, that the system performance can be improved when the system is allowed to saturate at low levels. This point is verified by viewing the system's step response shown in Fig. 21. Observe in the system output for the mild saturation case, MINA, the peak overshoot is slightly less than that for the unsaturated case, MIN. Additionally, the speed of system's response is reduced. However, this is expected. Whether a slower system with less overshoot is more desirable than a faster system with more overshoot is a question to be answered by considering the design specifications.

2. Fourth Order System

The same procedure used for the third order system is repeated for the fourth order system. Also, the same cost function, equation (5.0), is considered. Shown in Fig. 23 is the unit step response for this system. Outputs MIN, MINA, MINB represent the system performance for no saturation, mild saturation, and heavy saturation respectively. Even though the third and fourth order systems performance cannot be compared, the trends found for the third order system are also displayed by the fourth order system. Viewing Fig. 23 for the mild saturation case, output MINA, the system's response is slower and has a lower peak overshoot than the no saturation case, output MIN. For the heavy saturation case the system response is even slower than the mild saturation case. However, note that the peak overshoot is higher. If the system is driven further into saturation than that shown for the heavy saturation case, the system output becomes oscillatory.

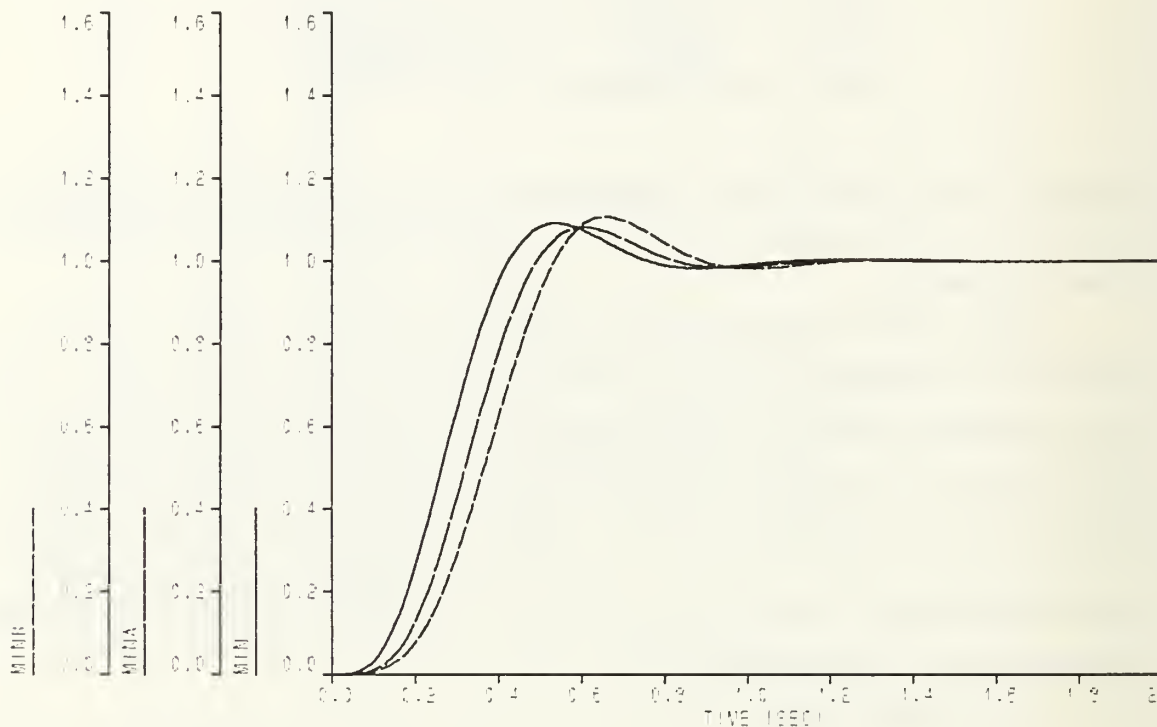

Figure 23. Fourth order system saturation response: Outputs MIN, MINA, and MINB represent the systems' response with no saturation, mild saturation, and heavy saturation respectively.

To further illustrate how the system performance is affected by saturation, the limiter output is shown in Fig. 24. System outputs U, LIMUA, and LIMUB represent the system's performance for no saturation, mild saturation, and heavy saturation respectively. Again it is shown how saturation affects the system control input. For the mild saturation case the control input is limited only during the highest positive peak. For the heavy saturation case, the control input is limited on both positive and negative peaks. Clearly, the system's control effort is limited to illustrate that the system is operating at maximum capacity. Hence the reason for the system outputs shown in Fig.

23 is illustrated. When the system is in saturation, output is produced at a slower rate than when no saturation is present.

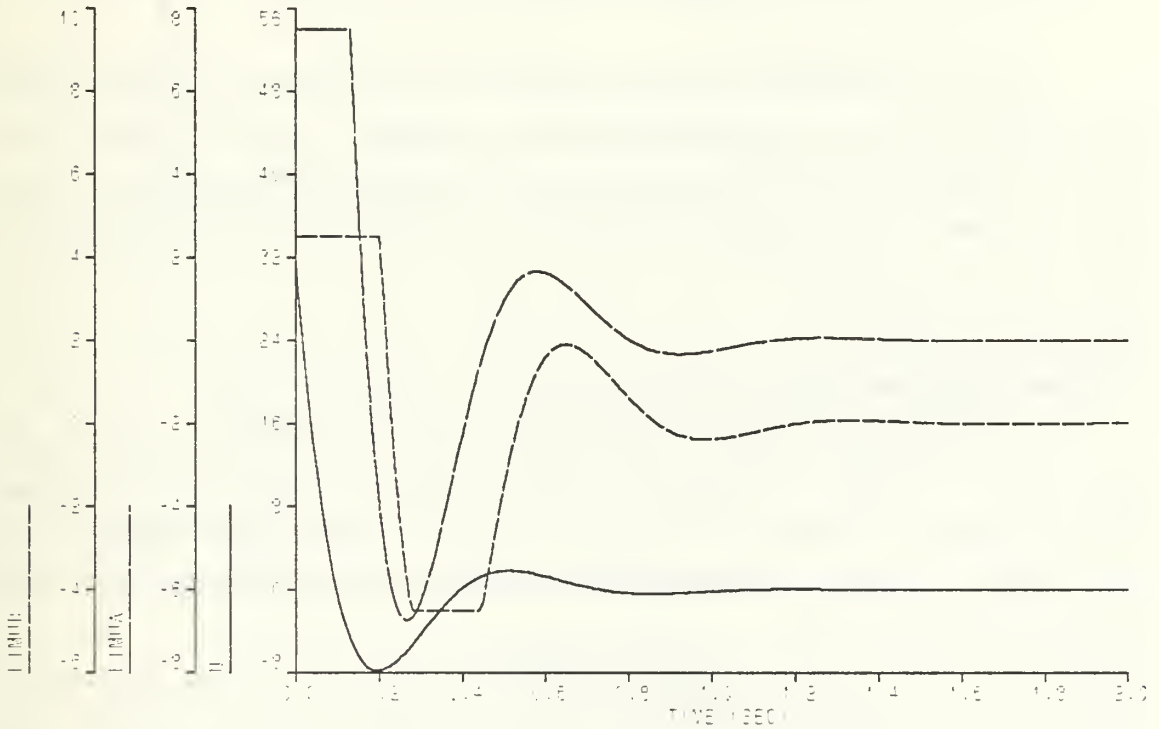

Figure 24. Fourth order system control effort changes: Variation of control effort, U and limiter output with mild saturation, LIMUA, and heavy saturation, LIMUB.

By evaluating the value of the cost function for the saturation levels shown in Fig. 24, it is expected that the cost will increase as the system is driven further into saturation. These results are shown in Table 9. These results show that the value of the cost function does indeed increase as the system is driven further into saturation.

Table 9. VALUE OF COST AT DIFFERENT SATURATION LEVELS

SATURATION LEVEL	COST
None	0.21214
Mild	0.26211
Heavy	0.30079

In order to determine if the system performance is improved when operated with mild saturation, the design specifications must be considered. Figure 23 shows that for the case of mild saturation the system does have a lower peak overshoot but its response time is increased. A determination of whether or not this response is more desirable than the no saturation case, faster but with more overshoot, is based on the desired system performance specifications.

B. COMPARISON WITH BODE DESIGN

In order to further investigate system performance in the presence of saturation, the system which was designed by weighting the control effort is compared to a Bode design. This comparison is completed for one specific reason. Chang [Ref. 2] states that a system design by weighting the control effort is less affected by saturation. This effect is investigated and verified.

Design of the Bode system is completed by simply designing a cascade compensator, or filter to give the desired output. In this case, the desired output is that which is similar to the output of the weighted minimized design. Only two specific designs are implemented, one each for the third and fourth order systems. For each of these systems only one value of the weighting factor was chosen to be designed. The third order Bode system was designed to approximate the minimized design for $Q = 0.005$, and the fourth order system was designed to approximate the minimized design for $Q = 0.001$. A block diagram of this implementation is shown in Fig. 25.

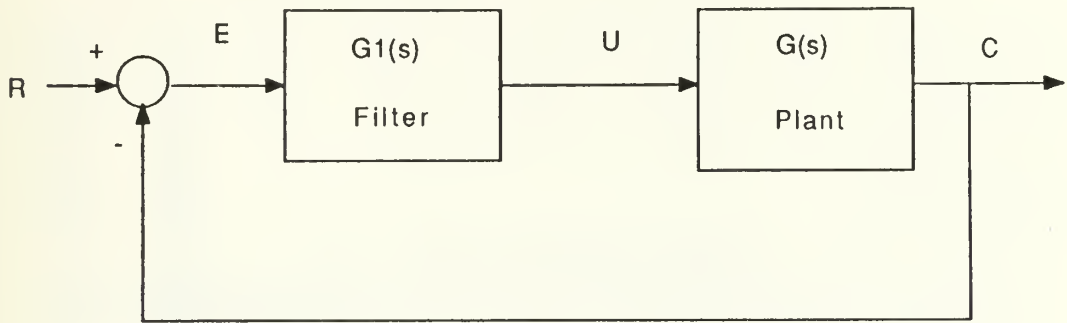

Figure 25. Implementation of Bode design: System arrangement for Bode design study. Note that the control effort, U , is generated by the filter.

1. Third order system

The transfer function for the filter of this design is

$$G_1(s) = \frac{104.17(s + 2)(s + 6)}{(s + 20)(s + 50)} \quad (5.1)$$

The plant transfer function is

$$G(s) = \frac{96}{s(s + 2)(s + 6)} \quad (5.2)$$

Upon completion of the design, the system was simulated and the output compared to that of the weighted minimized design. Shown in Fig. 26 is the unit step response for the Bode and minimized designs. Even though the response of the two designs are not identical they are close enough to illustrate the main objective. Figure 27 shows the control effort variations for both design methods.

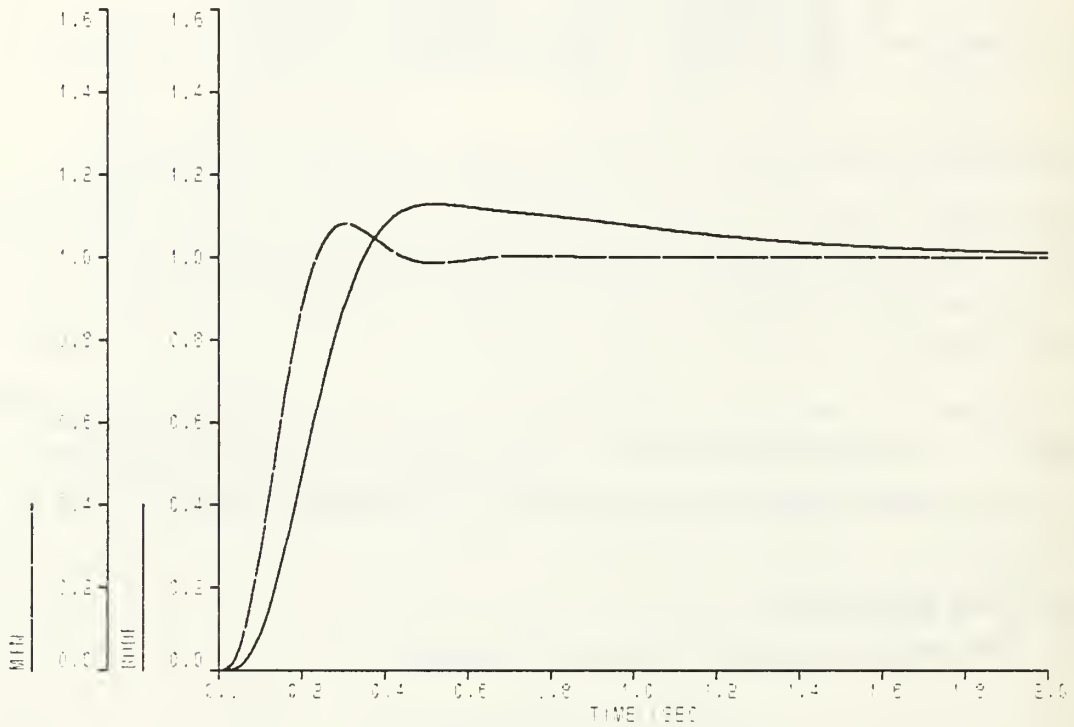

Figure 26. Bode and minimized design unit step response: Outputs BODE and MIN represent Bode and minimized response respectively.

While the overall shape of the control effort for both designs are basically the same, there are significant differences. Note that for the minimized response, UM, the control efforts starts at a maximum value and goes to zero. For the Bode design however, the control effort, UB, starts at zero, increases to a maximum, and decays to zero. These differences are expected because of the two different designs used.

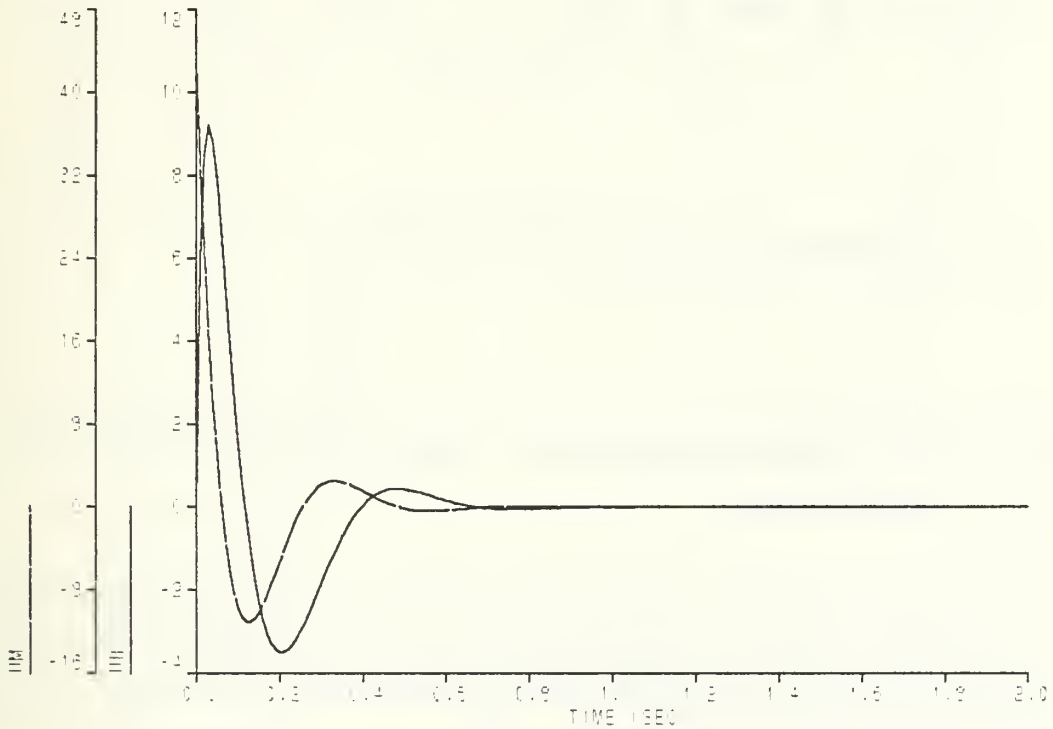

Figure 27. Control effort for Bode and minimized design, no saturation: UB and UM represent control effort for the Bode and minimized designs respectively.

Since it is desired to determine how saturation affects the weighted minimized design, the Bode design is used as an alternative design for comparison purposes. In order to introduce saturation into the Bode design, Figure 28 presents a block diagram illustrating limiter placement. Limiter placement for the minimized system is shown in Fig. 20. Three different levels of saturation were introduced: ± 10 V, ± 5 V, and ± 2 V. A unit step input was applied to both systems for all saturation cases studied.

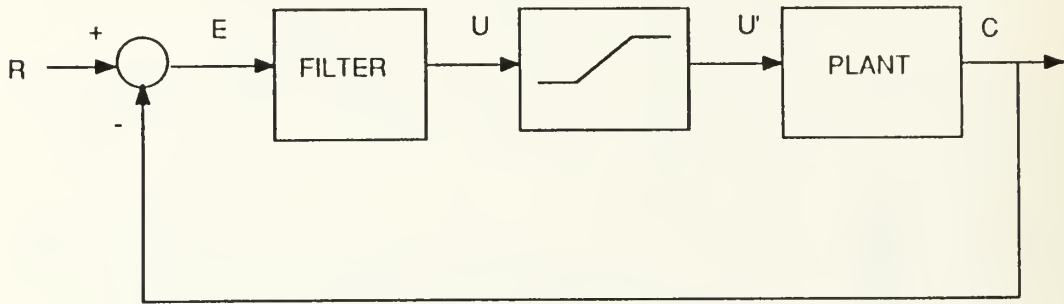

Figure 28. Bode design limiter placement: Limiter placed at plant input to simulate saturation.

Figure 29 presents the unit step response for these two designs with saturation set at a ± 10 V level. At this saturation level there is no noticeable change in outputs for either designs. Figure 30 shows the changes in the control effort. Note that the Bode design control effort, LBUA, is not yet affected by saturation. Therefore, its unit step response is unchanged. However, saturation does effect the minimized system's control effort, LMUA. However, there is no noticeable change in the system's step response.

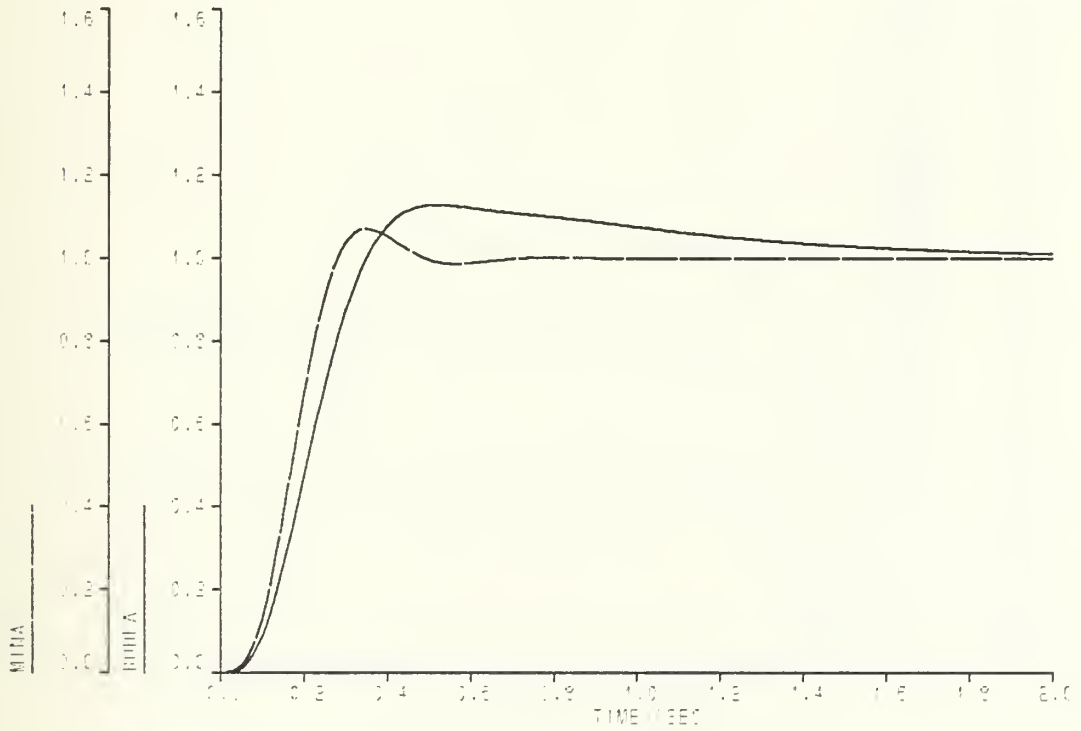

Figure 29. Bode and minimized designs, saturation level ± 10 V: Output BODEA, and MINA represent the Bode and minimized designs respectively.

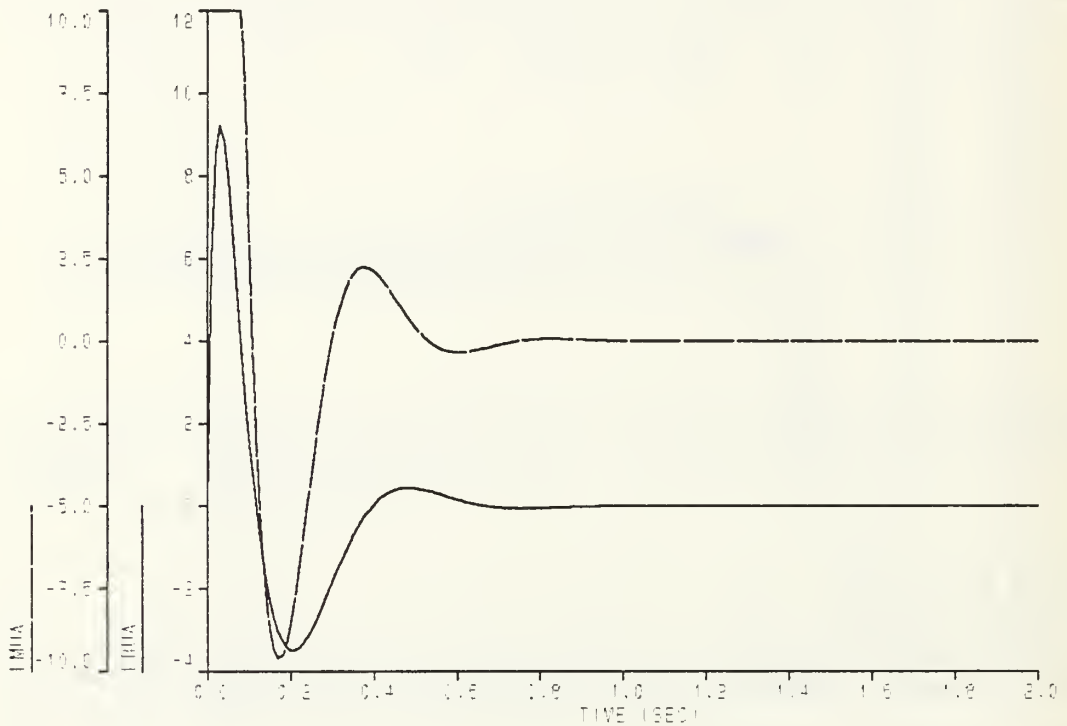

Figure 30. Control effort changes, saturation level ± 10 V: Outputs LBUA, and LMUA represent limiter output for the Bode and minimized designs.

Placing the system further into saturation is accomplished by reducing the limiter levels. Shown in Fig. 31 is the unit step response for the systems with saturation set at ± 5 V. Clearly, there are noticeable differences in the output for the minimized design. However, the changes in the Bode design are more drastic. Again, the system outputs are BODEA and MINA for the Bode and the minimized designs respectively. Note that, while the minimized design has slightly more overshoot, its overall shape is maintained. The Bode design, however, shows significant changes. Clearly the overshoot is no longer present and the system has become critically damped. Variations in the systems control effort are shown in Fig. 32.

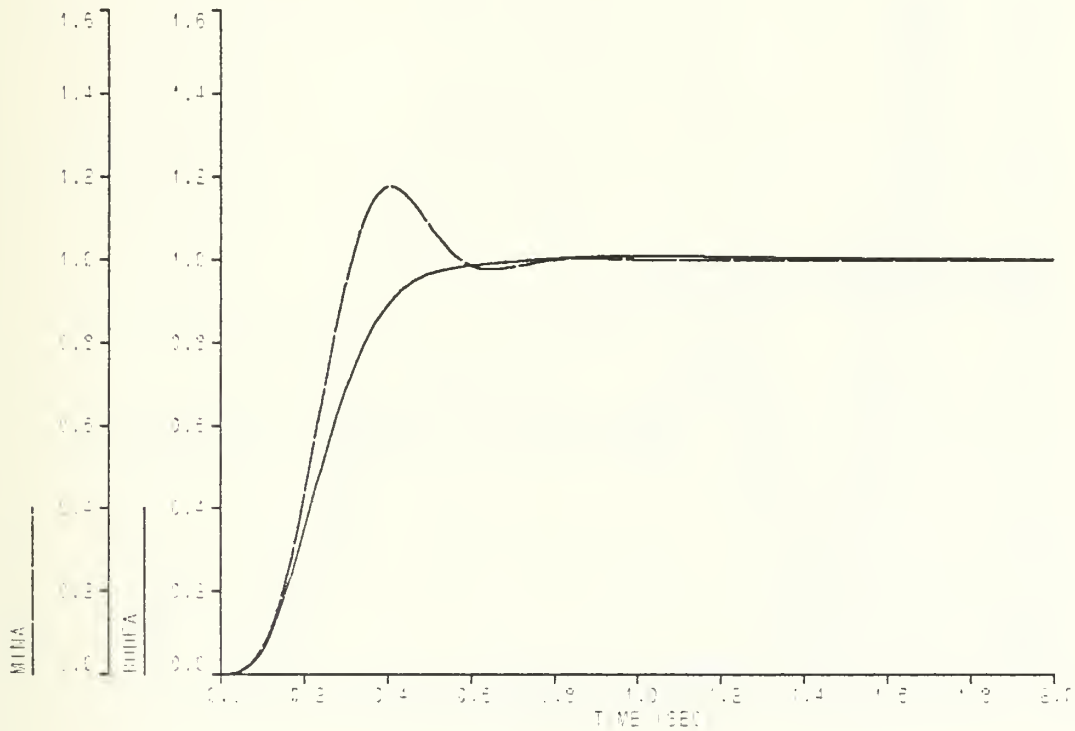

Figure 31. Bode and minimized system response, saturation level ± 5 V: Outputs BODEA and MINA represent Bode and minimized design response respectively.

System outputs are as previously noted. Clearly, the effects of the limiter is illustrated. For the minimized system saturation takes place on positive and negative peaks of the control effort. Saturation takes place on only the positive peaks however for the Bode design. Note the difference in the response as seen in Fig. 31. The Bode design is more significantly degraded than the minimized design for the same saturation.

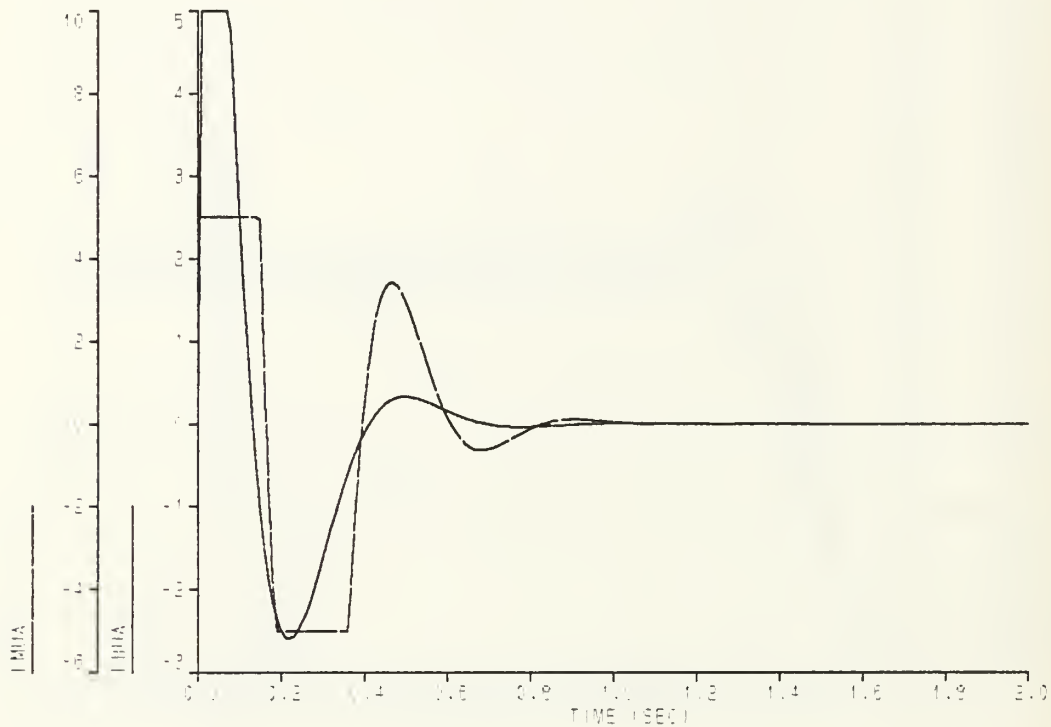

Figure 32. Control effort changes, saturation level ± 5 V: Outputs LBUA and LMUA represent Bode and minimized designs respectively.

In order to see if this trend is continued, Fig. 33 shows the unit step response for these systems when saturation is set at ± 2 V. Clearly, there are significant differences in the response for both designs. The Bode design is clearly over damped. The minimized response has maintained its original shape even though its peak overshoot is significantly higher. Figure 34 shows the changes in the control effort for these two designs. It is obvious that the minimized system is further into saturation than the Bode design.

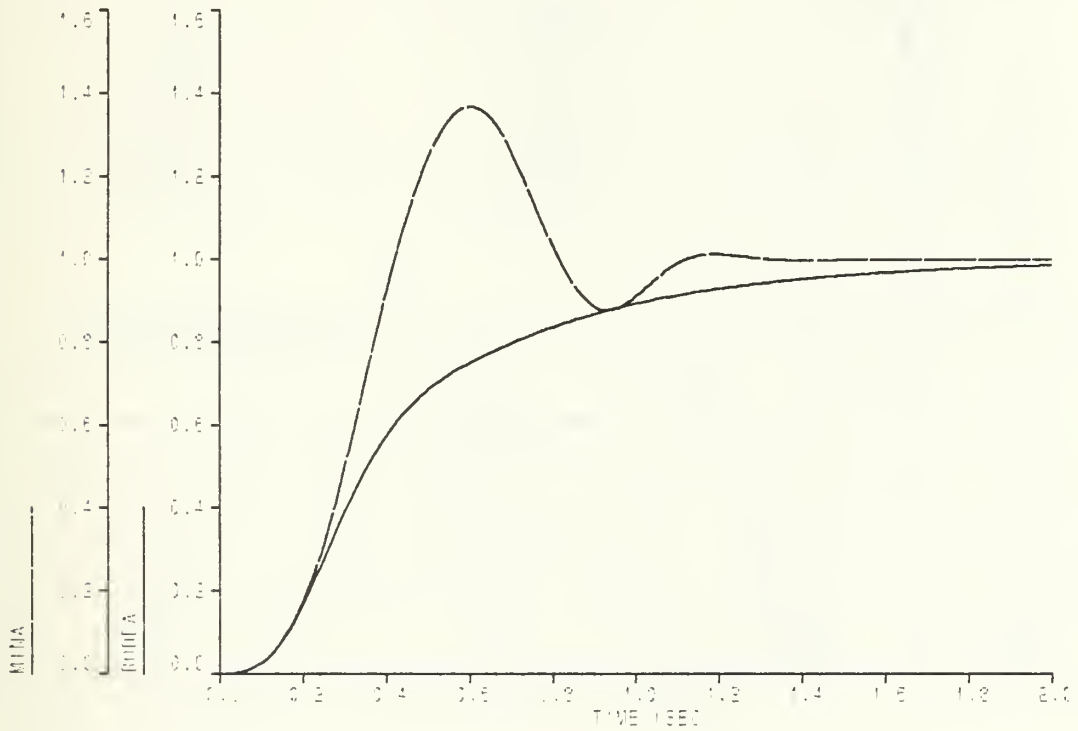

Figure 33. Bode and minimized system response, saturation level ± 2 V: Outputs BODEA and MINA represent Bode and minimized designs respectively.

Note output LMUA; it swings from positive to negative and back into positive saturation. The Bode design however, output LBUA, is only saturated on the positive peak. Based on the amount of time each system is in saturation, the minimized system response is better than the Bode design. In order to gain further appreciation of how saturation effects these two designs, Table 10 presents the cost for each design at each saturation level.

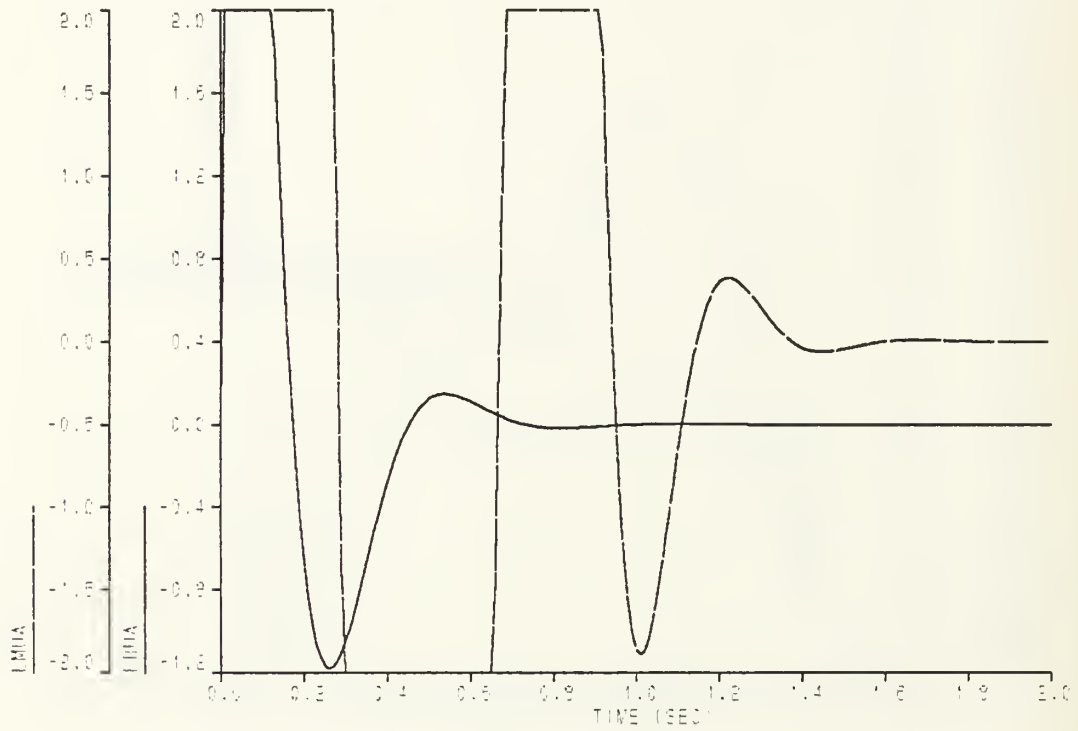

Figure 34. Control effort changes, saturation level ± 2 V: Output LBUA and LMUA represent Bode and minimized designs respectively.

Table 10. SATURATION COST SUMMARY BODE AND MINIMIZED DESIGNS

SATURATION LEVEL	BODE DESIGN COST	MINIMIZED DESIGN COST
NONE	0.174	0.125
$\pm 10 V$	0.174	0.137
$\pm 5 V$	0.194	0.174
$\pm 2 V$	0.300	0.267

Here the weighted cost function shown in equation (5.0) is evaluated. Viewing these results it is clear that as each system is driven farther into saturation the cost increases. Even though there is a more significant cost increase for the minimized design, its response is clearly more acceptable than the Bode design. If the cost is computed only for the integral of error squared, IES, for these two designs totally discounting the effects of weighting the control effort, these trends are continued. Table 11 shows these costs. Note that for each level of saturation the cost increases, but the cost for the minimized system is less than that for the Bode system in all cases. Hence, the effects of saturation are less.

Table 11. IES SATURATION COST SUMMARY BODE AND MINIMIZED DESIGNS

SATURATION LEVEL	BODE DESIGN COST	MINIMIZED DESIGN COST
NONE	0.171	0.104
$\pm 10 V$	0.171	0.137
$\pm 5 V$	0.192	0.174
$\pm 2 V$	0.298	0.267

2. Fourth order system

Repeating this process for the fourth-order system, the trends established earlier are clearly evident and maintained. The transfer function for the final filter design for this system is

$$G_1(s) = \frac{811.64(s+2)(s+6)(s+9)}{(s+15)(s+20)(s+200)} \quad (5.3)$$

The plant transfer function is

$$G(s) = \frac{493.1}{s(s+2)(s+6)(s+9)} \quad (5.4)$$

Again the system is simulated and the response of the Bode design is compared to that of the weighted minimized design response. Figure 35 presents the unit step response for each design method. Clearly the response for these two designs are close enough for the saturation study to be conducted. The Bode design has more overshoot, but this will help illustrate the desired effects. Also shown in Fig. 36 is the changes in the control effort for these two designs.

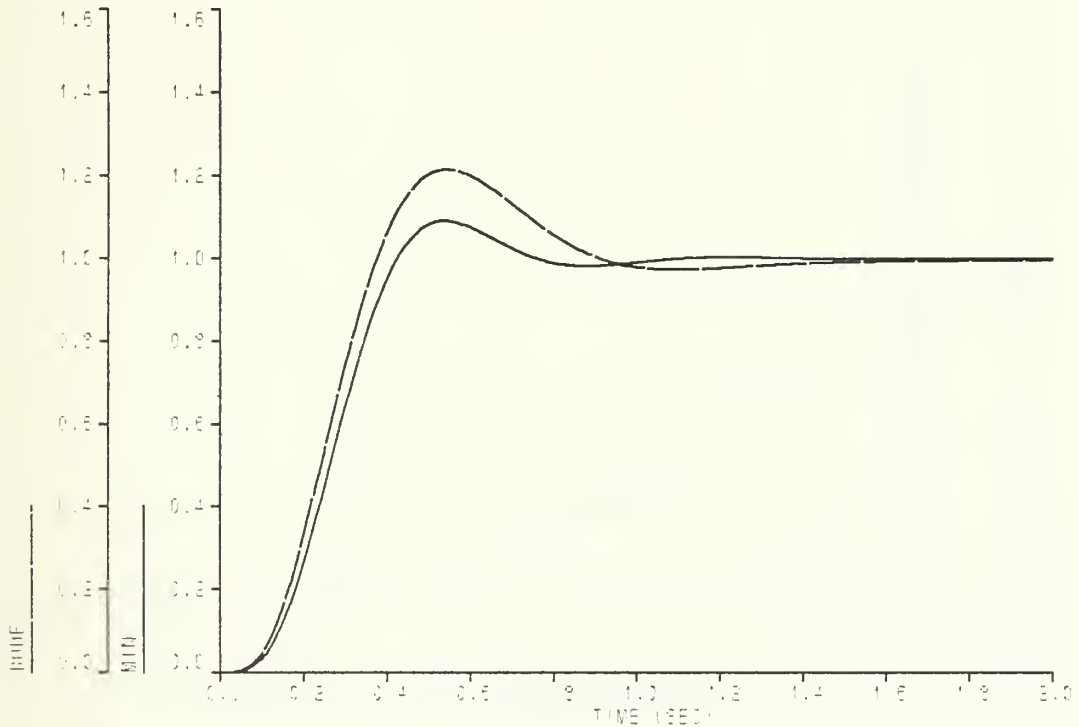

Figure 35. Bode and minimized design unit step response: Output for these designs are reasonably close; no saturation is present.

Clearly the shapes of the transient portion of the response are the same with one exception. The control effort for the Bode design, output UB, starts at zero builds to a maximum and proceeds to zero. However, the minimized design starts at a maximum value and proceeds to zero. These differences are due to the poles and zeros of the filter transfer function for the Bode design. Even though these differences exist in the control effort for the two designs, the output for each is as desired.

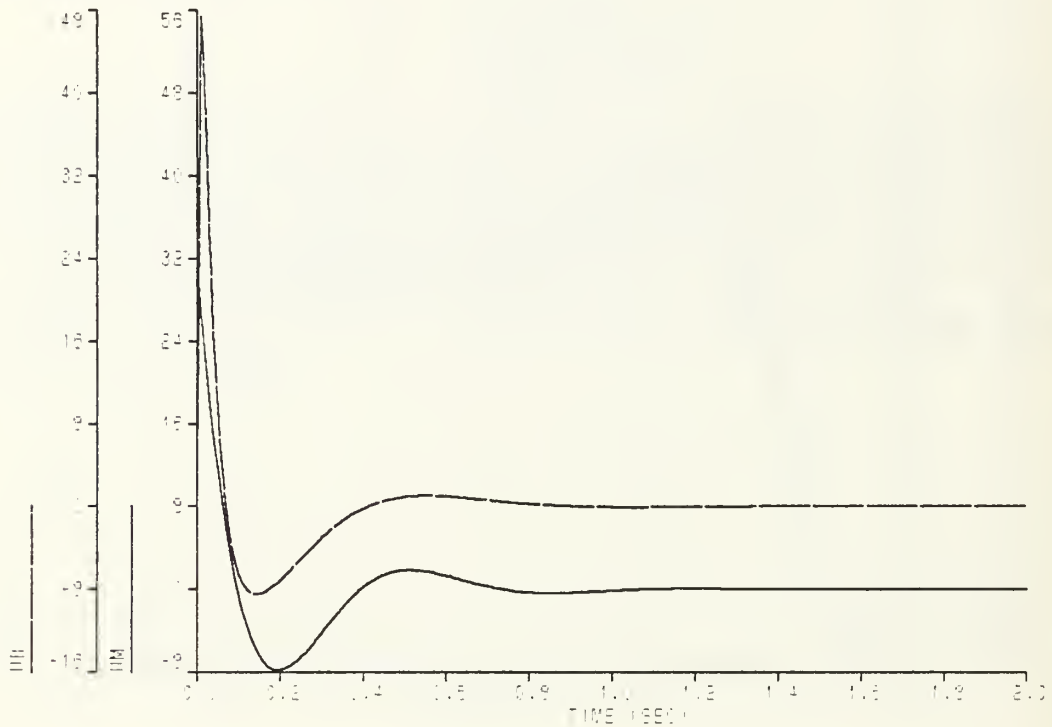

Figure 36. Control effort for Bode and minimized designs, no saturation: Outputs UB and UM represent Bode and weighted minimized designs respectively.

Shown in Fig. 37 is the unit step response for these designs when saturation is introduced at a level of ± 10 V. Clearly the effects of saturation are obvious. Note the drastic change in the Bode response. Even though it finally reaches steady state, it is clearly over damped. Figure 38 presents the control effort for these two designs.

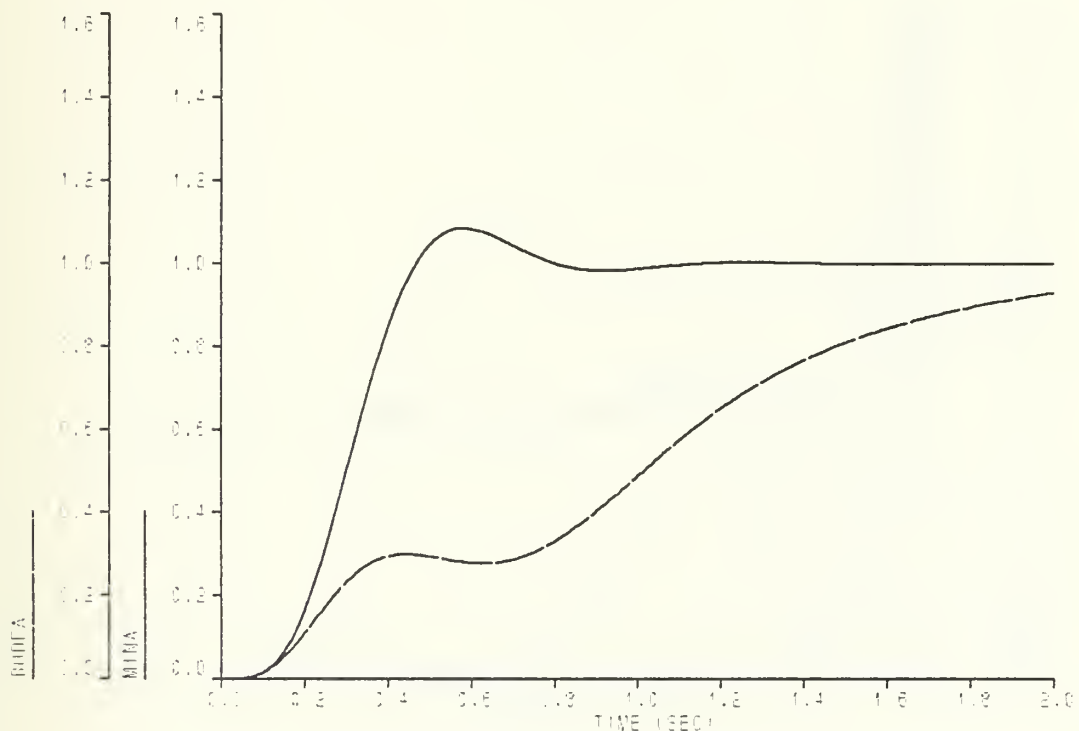

Figure 37. Bode and minimized design step response, saturation level ± 10 V:
 Effects of saturation are obvious. Note how significantly the Bode response, output BODEA, is affected. The minimized response remains unchanged.

By limiting the maximum excursion of the control effort to 10 V, it is never allowed to reach its maximum value. Saturation clearly has a significant effect on the Bode design.

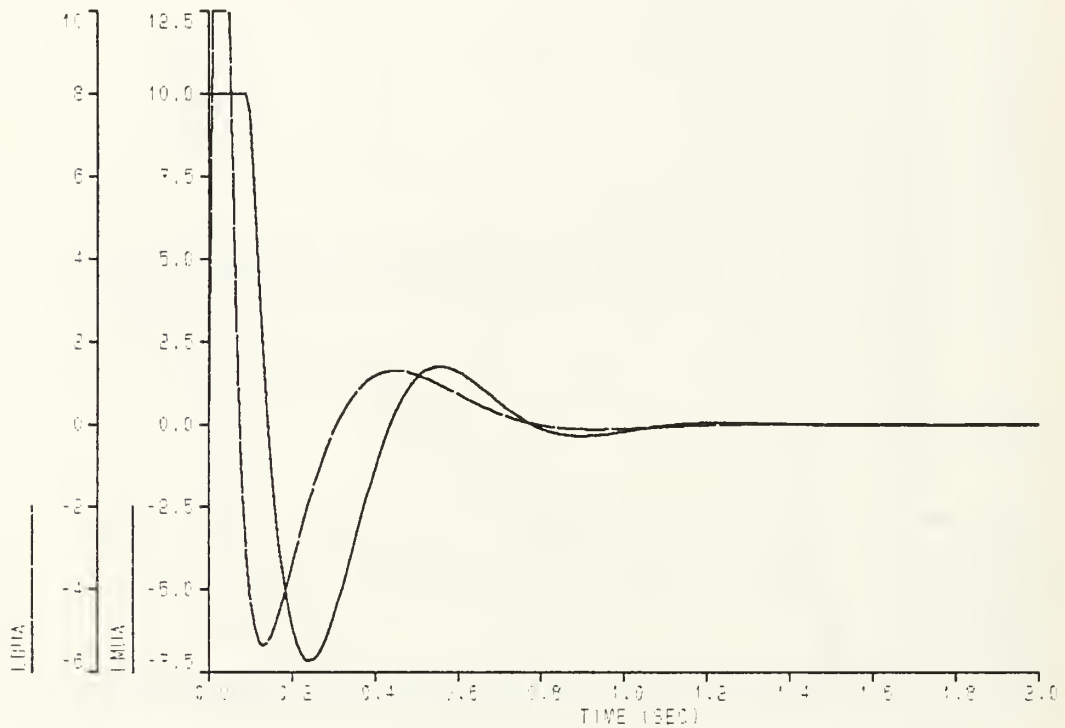

Figure 38. Control effort changes saturation level ± 10 V: Saturation at this level does not allow the control effort for the Bode design, output LBUA, to reach its maximum value.

By allowing this system further into saturation the Bode response is further deteriorated. Shown in Fig. 39 is the step response for a saturation level of ± 5 V. As expected the Bode response is further degraded. Note that the minimized design response maintains its shape with only a minor increase in maximum overshoot. The control effort variations for this level of saturation are shown in Fig. 40.

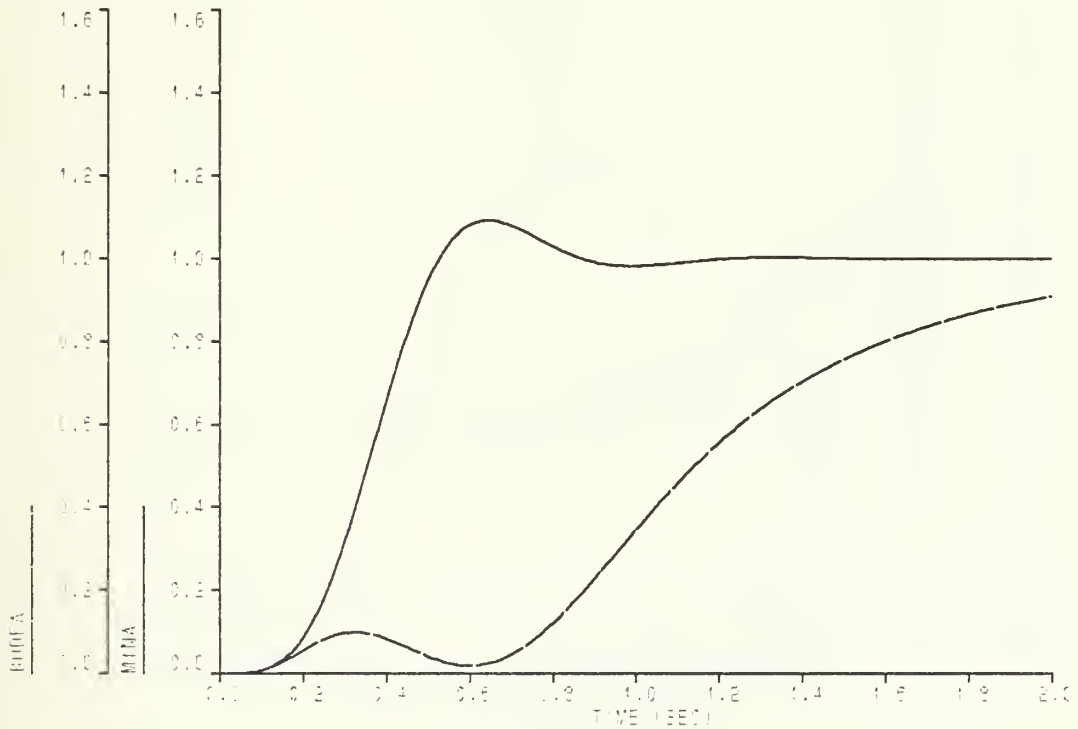

Figure 39. Bode and minimized design step response, saturation level ± 5 V:
 Bode response, output BODEA, significantly affected. Minimized response maintains its shape with only a minor increase in maximum overshoot.

Note that the control effort for the minimized design, output LMUA, is in saturation on both positive and negative peaks. The effect on the step response is minimal. However, the control effort for the Bode design is saturated only on its positive peak, output LBUA, and for less time, but its effect on the step response is clearly more significant.

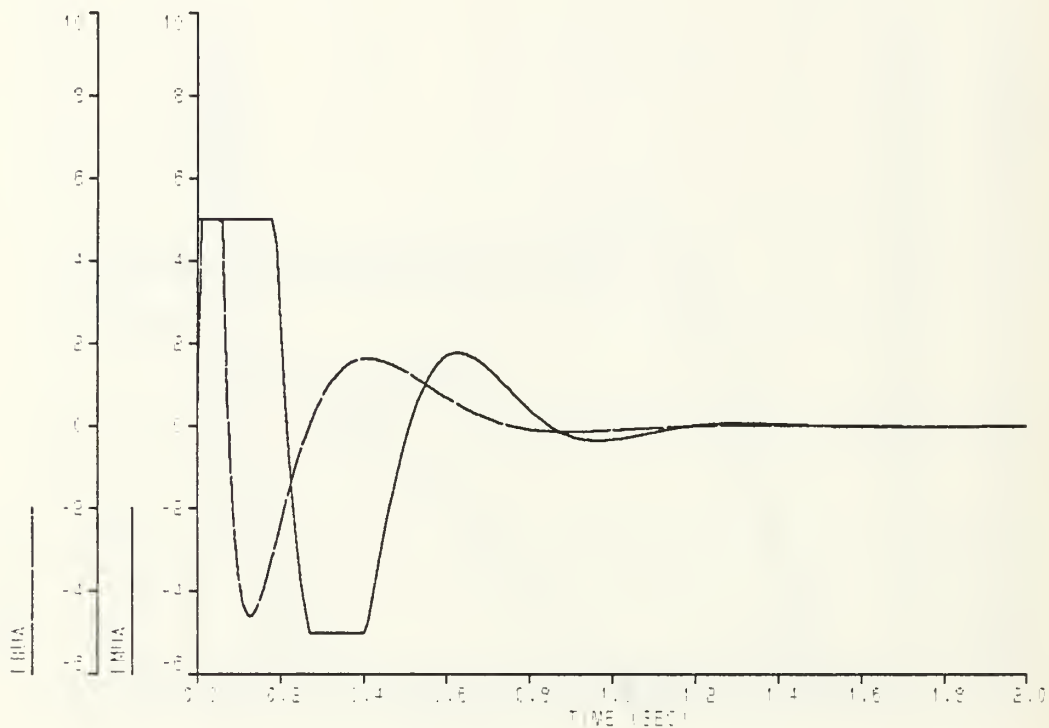

Figure 40. Control effort changes, saturation level ± 5 V: Control effort for Bode design, LBUA, is in saturation for only a short period, but its effect is significant.

The unit step response for a saturation level of ± 2 V is shown in Fig. 41. Again the Bode design is significantly affected by saturation. But note the changes in the minimized design response, output MINA. Even though there is more overshoot, this design response is clearly more acceptable. Figure 42 shows the changes in control effort for ± 2 V level of saturation.

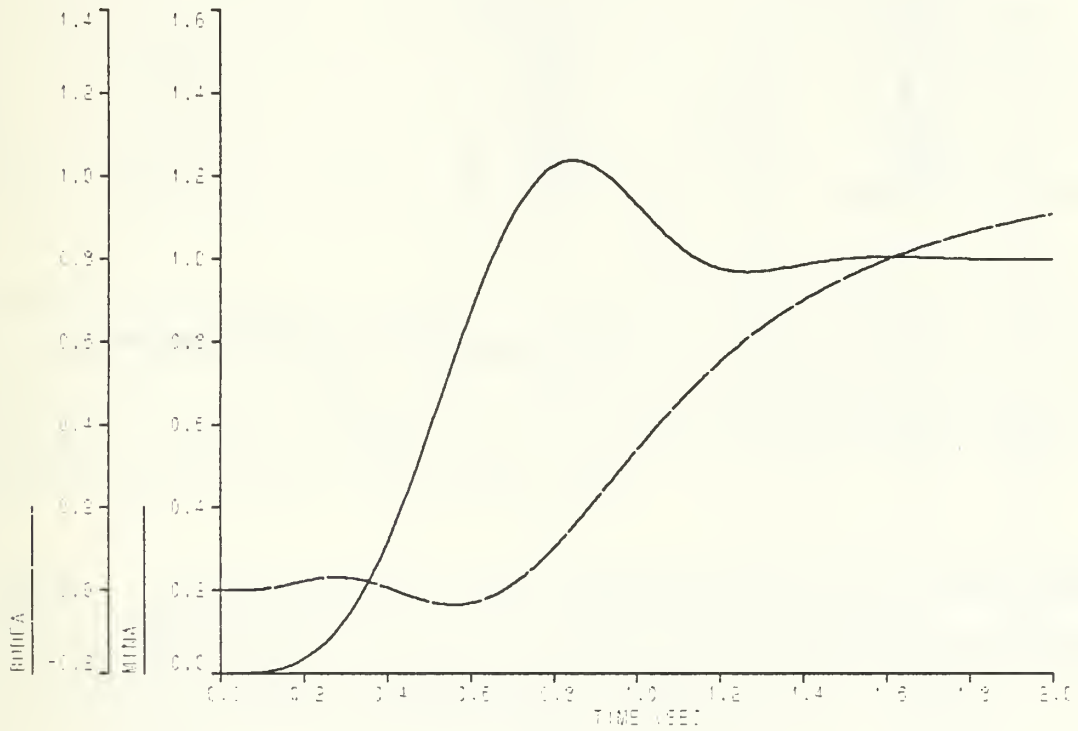

Figure 41. Bode and minimized design step response, saturation level ± 2 V: Bode design is severely affected by saturation, output BODEA. Minimized design response deteriorated but less than Bode design.

Note that for the first time the control effort for the Bode design is saturated on both positive and negative peaks, output LBUA. Also note that the minimized design is limited on positive peaks for considerably more time, output LMUA, but the effect is not as significant as for the Bode design.

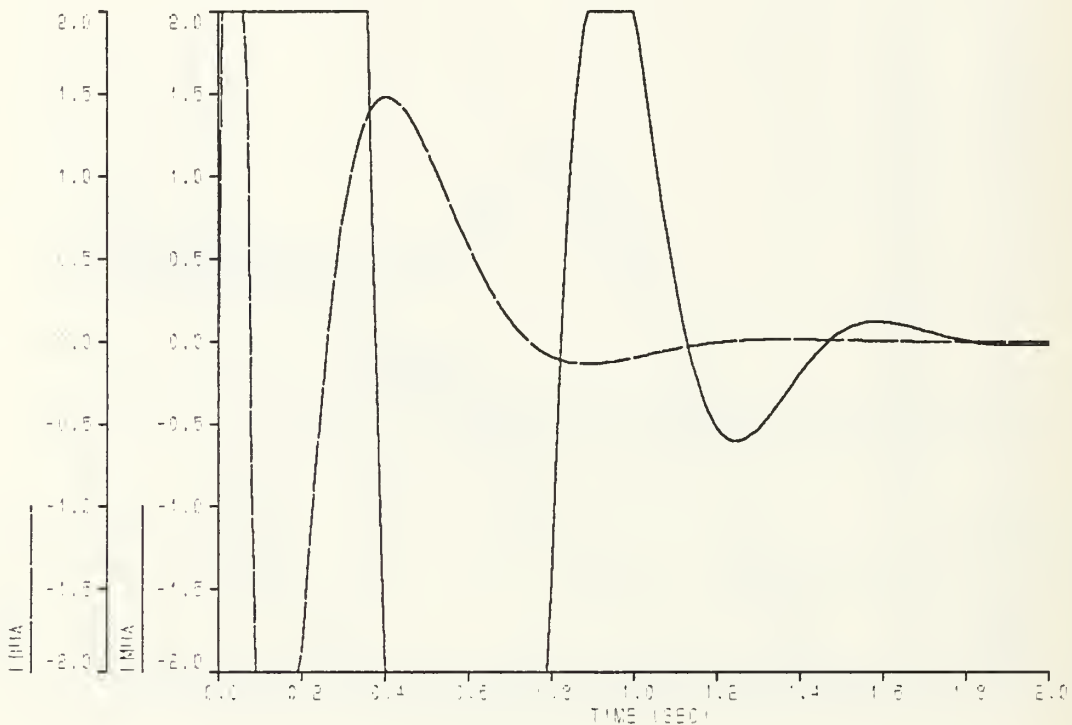

Figure 42. Control effort changes, saturation level ± 2 V: Bode design significantly affected by saturation, output LBUA. Minimized design is clearly deteriorated but not as significantly as Bode the design.

Clearly the minimized design response is more acceptable even though its response is slower than the no saturation case. The speed of the response is slower, as expected, because each system receives power at a lower rate.

In order to determine how saturation affects the cost for each design while in saturation, Table 12 presents the cost for each design at each saturation level.

Table 12. SATURATION COST SUMMARY BODE AND MINIMIZED DESIGNS

SATURATION LEVEL	BODE DESIGN COST	MINIMIZED DESIGN COST
NONE	0.265	0.246
$\pm 10 V$	0.657	0.245
$\pm 5 V$	0.953	0.291
$\pm 2 V$	1.022	0.397

Note that for each level of saturation there is a cost increase. However, the cost for the minimized system is considerably less than the cost for the Bode designed system. If cost is evaluated for only the integral of error squared, IES, for both design methods, totally discounting the effect of weighting the control effort for the minimized design, these trends are repeated. Table 13 shows these results.

Table 13. IES SATURATION COST SUMMARY BODE AND MINIMIZED DESIGNS

SATURATION LEVEL	BODE DESIGN COST	MINIMIZED DESIGN COST
NONE	0.204	0.212
$\pm 10 V$	0.649	0.245
$\pm 5 V$	0.949	0.292
$\pm 2 V$	1.021	0.397

As expected, these results show that as the amount of saturation is increased, the cost is also increased. By evaluating the IES cost for both design methods, the difference in cost for the two design methods are more pronounced. However, only the minimized design was specifically designed for minimum cost. The Bode design was completed with no consideration given to cost.

Based on these results for both the third and fourth order systems, the minimized design response is clearly superior to that of the Bode design when operated in the presence of saturation.

VI. CONCLUSIONS

As stated in the introduction, the purpose of this study was to examine the relationships, if they exist, between the cost functions

$$J = \int_0^{\infty} E^2 dt \quad (6.0)$$

and

$$J = \int_0^{\infty} (E^2 + QU^2) dt \quad (6.1)$$

and the closed loop roots of arbitrarily chosen Type I all-pole plants. First, a determination was made on how the cost functions affected the characteristic roots for the plants

$$G(s) = \frac{96}{s(s+2)(s+6)} \quad (6.2)$$

and

$$G(s) = \frac{493.1}{s(s+2)(s+6)(s+9)} \quad (6.3)$$

Specifically, it was desired to determine if the characteristic roots tend to a particular pattern as a result of minimizing these cost functions. Second, the effect of weighting the control effort on the characteristic roots was considered in order to determine if the characteristic roots again formed a unique pattern. Finally, the effect on system performance in the presence of saturation was considered to determine if the systems' response could be improved.

As a result of minimizing the cost function shown in equation (6.0), the integral of the error squared, the characteristic roots do tend to the same locations found by using the standard form for the integral of error squared. However, in order to reach this re-

sult, using function minimization, a specific technique must be used. First, the desired system bandwidth must be known. This value will usually be dictated by the given system specifications. Second, special consideration must be given to the initial values used in the function minimization program. If they are chosen arbitrarily, the minimization program may converge to a local minimum, or it may not converge at all. After numerous attempts were made at choosing initial values using many different methods, all of which failed to give satisfactory results, a successful method was finally determined. Since no prior knowledge of system behavior was known, the standard form for the integral of error squared was used to help pick these initial values successfully.

To illustrate this procedure, the standard form for the third order integral of error squared system is

$$s^3 + \omega_0 s^2 + 2\omega_0^2 s + \omega_0^3 \quad (6.4)$$

For this study the value for ω_0 was chosen arbitrarily. This value, 20 rad/sec, was substituted into the standard form giving

$$s^3 + 20s^2 + 800s + 8000 \quad (6.5)$$

Since full state feedback was used to implement the function minimization program, the characteristic equation for this system was placed in the form

$$s^3 + (8 + 96k_2)s^2 + (12 + 96k_1)s + 96k_0 \quad (6.6)$$

Equating coefficients, the feedback gains are

$$k_0 = 83.33 \quad (6.7)$$

$$k_1 = 8.21 \quad (6.8)$$

$$k_2 = 0.125 \quad (6.9)$$

Using these values as initial guesses, the function minimization program converges rapidly. Finally, the amount of time chosen to run the simulation must be carefully determined. If it is not, considerable time can be spent minimizing the cost function and, hence, the dollar cost for computer CPU time is increased significantly. System performance specifications should help determine a good choice for simulation run time.

As a consequence of these results, for linear control systems in which it is desired to minimize system error, the standard form can be used to complete the design. If this

design meets specifications no further work is required. However, if this design does not meet specifications other design methods must be used.

As a result of weighting the control effort, the characteristic roots were found to tend to the Butterworth pattern as pointed out by Chang [Ref. 2]. However, there is no technique for choosing the weighting factor, Q . The symmetric root locus was used in this study to help determine values for the weighting factor. However, its use was limited and only served to indicate that the system characteristic roots were moving in the proper direction. For some choices of the weighting factor the characteristic roots did not always agree with the root locus as expected. The actual reason for this behavior is unknown. This behavior *may* indicate that a local minimum was determined. This behavior is recommended for further study.

As a result of evaluating the system performance in the presence of saturation it was determined that the system performance may be improved. If the system is allowed to saturate moderately, the performance is not significantly affected. Even though the system response time is increased, it is usually acceptable. However, if the system is heavily saturated, the performance rapidly deteriorates and is unsatisfactory.

The comparison of Bode and minimized designs gave interesting results. These results show that the system designed by weighting the control effort when minimizing the cost function does perform better in the presence of saturation. However, it must be noted that the Bode design was completed using cascade compensation, and the minimized design was completed using state variable feedback. The fact that different methods were used to implement each design may have affected the results. However, the results obtained do support Chang's proposal [Ref. 2] that systems designed by minimizing the cost function in which the control effort is weighted, equation (6.1), perform better in the presence of saturation. Comparison of the minimized design with systems designed using other methods is recommended for future study.

Saturation studies for the integral of error squared were not conducted and are recommended for future study. Also, the saturation response for the systems studied was limited to a single value of the weighting factor in order to keep the study manageable. It is understood that generalizations should not be made based on insufficient information. It is not put forth that these conclusions apply to all linear systems. These results do indicate trends in system performance. Before they can be applied categorically to all linear control systems, they do require and are recommended for further study.

APPENDIX

The following programs were used to produce the data used in this case study. These programs were written for use with Dynamic Simulation Language/VS, DSL. Other programs used but not listed were ALCON and EWALD/VS.

```
*****
*   THESIS RESEARCH : FUNCTION MINIMIZATION 3RD ORD SYS   *
*   THIS PROGRAM MINIMIZES THE COST FUNCTION, THE INTEGRAL*
*   OF ERROR SQUARED AND RETURNS FEEDBACK GAINS REQUIRED.  *
*   THE VARIABLE K0 IS CONSTRAINED IN THIS PROBLEM       *
*   SO THAT W0 IS FIXED.                                  *
*****
*
D      COMMON/HANDJ/FLAG,COST,K1,K2
TITLE MINIMIZATION OF INTGRL(E**2),3RD ORD SYSTEM  K0 FIXED
*
*   X(2) = K1, X(3) = K2
INCON  IC0=0.0
CONST  K10=1.9583333,  K20=.02083333
CONST  K0 = 10.41677
INITIAL
      IF(FLAG.GE.0.0)GO TO 5
      K1 = K10
      K2 = K20
      5  CONTINUE
      FLAG = FLAG + 1
*
*
DERIVATIVE
      R = 1.0 * STEP(0.0)
      E = R - OUTPUT
      I = K0 *E - K2 * X2D
      U = I - K1*XD
      X3D = 96 * U - 8 * X2D - 12 * XD
      X2D = INTGRL(IC0,X3D)
      XD = INTGRL(IC0,X2D)
      OUTPUT = INTGRL(IC0,XD)
      FCNER = E**2
      E1 = INTGRL(IC0,FCNER)
CONTROL FINTIM = 5.0
TERMINAL
      COST = E1
END
STOP
*
*
FORTRAN
*   INITIALIZATION OF PARAMETERS FOR HOOKE SUBROUTINE
```

```
IMPLICIT REAL*8(A-H,O-Z)
DIMENSION X(2),STEP(2),Q(2),QQ(2),W(2)
STEP(1) =0.001
STEP(2) = .0001
N = 2
ITMAX = 500
CFTOL = .0001
ALPHA = 2.0
BETA = 0.5
IPRINT = 0
MINMAX = -1
CALL HOOKE(X,STEP,N,ITMAX,CFTOL,ALPHA,BETA,CF,Q,QQ,W,
1IPRINT,MINMAX)
STOP
END
```



```

*****
*   THESIS RESEARCH : FUNCTION MINIMIZATION 4TH ORD SYS   *
*   THIS PROGRAM MINIMIZES THE COST FUNCTION, THE INTEGRAL*
*   OF ERROR SQUARED AND RETURNS FEEDBACK GAINS REQUIRED.  *
*   K0 IS CONSTRAINED TO LIMIT W0.                        *
*****
*
D      COMMON/HANDJ/FLAG,COST,K1,K2,K3
TITLE  MINIMIZATION OF INTGRL(E**2),4TH ORD SYSTEM, K0 FIXED
*
*   X(2) = K1, X(3) = K2,X(4) = K3
INCON  IC0=0.,K10=32.2287568,K20=2.2632000,K30=6.0839586E-03
CONST  K0 = 324.477793
INITIAL
      IF(FLAG.GE.0.0)GO TO 5
      K1 = K10
      K2 = K20
      K3 = K30
5      CONTINUE
      FLAG = FLAG + 1
*
*
DERIVATIVE
      R = 1.0 * STEP(0.0)
      E = R - OUTPUT
      M1 = K0 *E - K3 * X3D
      I = M1-K2*X2D
      U = I - K1*XD
*
      X4D =493.1*U-17*X3D-84*X2D-108*XD
      X3D = INTGRL(IC0,X4D)
      X2D = INTGRL(IC0,X3D)
      XD = INTGRL(IC0,X2D)
      OUTPUT = INTGRL(IC0,XD)
      FCNER = E**2
      E1 = INTGRL(IC0,FCNER)
CONTROL FINTIM = 3.0
TERMINAL
      COST = E1
END
STOP
*
*
FORTRAN
* INITIALIZATION OF PARAMETERS FOR HOOKE SUBROUTINE
      IMPLICIT REAL*8(A-H,O-Z)
      DIMENSION X(3),STEP(3),Q(3),QQ(3),W(3)
      STEP(1) = .001
      STEP(2) = .0001
      STEP(3) = .00001
      N = 3
      ITMAX = 500
      CFTOL = .0001
      ALPHA = 2.0
      BETA = 0.5
      IPRINT = 0

```

```
MINMAX = -1  
CALL HOOKE(X,STEP,N,ITMAX,CFTOL,ALPHA,BETA,CF,Q,QQ,W,  
1IPRINT,MINMAX)  
STOP  
END
```

```

*****
*   THESIS RESEARCH : FUNCTION MINIMIZATION 3RD ORD SYS   *
*   THIS PROGRAM MINIMIZES THE COST FUNCTION, THE INTEGRAL*
*   OF ERROR SQUARED PLUS A WEIGHTING FACTOR (Q) TIMES   *
*   THE CONTROL EFFORT SQUARED AND RETURNS FEEDBACK      *
*   GAINS REQUIRED TO MINIMIZE THIS COST FUNTION.         *
*****
*
D      COMMON/HANDJ/FLAG,COST,K0,K1,K2
TITLE  MINIMIZATION OF INTGRL(E**2+Q*U**2),3RD ORD SYSTEM
*
* X(1) = K0, X(2) = K1, X(3) = K2
INCON  ICO=0.
CONST  K00=42.698049 , K10=5.2332549 , K20=.30510201
CONST  Q = 0.00001
INITIAL
      IF(FLAG.GE.0.0)GO TO 5
      K1 = K10
      K2 = K20
      K0 = K00
5      CONTINUE
      FLAG = FLAG + 1
*
*
DERIVATIVE
      R = 1.0 * STEP(0.0)
      E = R - OUTPUT
      I = K0 *E - K2 * X2D
      U = I - K1*XD
*
      X3D = 96 * U -8*X2D - 12 *XD
      X2D = INTGRL(ICO,X3D)
      XD = INTGRL(ICO,X2D)
      OUTPUT = INTGRL(ICO,XD)
      FCNER = E**2+Q*U**2
      E1 = INTGRL(ICO,FCNER)
CONTROL FINTIM = 3.00
TERMINAL
      COST = E1
END
STOP
*
*
FORTRAN
* INITIALIZATION OF PARAMETERS FOR HOOKE SUBROUTINE
  IMPLICIT REAL*8(A-H,O-Z)
  DIMENSION X(3),STEP(3),Q(3),QQ(3),W(3)
  STEP(1) = .001
  STEP(2) = .00001
  STEP(3) = 0.000001
  N = 3
  ITMAX = 500
  CFTOL = .00001
  ALPHA = 2.0
  BETA = 0.5
  IPRINT = 0

```

```
MINMAX = -1  
CALL HOOKE(X,STEP,N,ITMAX,CFTOL,ALPHA,BETA,CF,Q,QQ,W,  
1IPRINT,MINMAX)  
STOP  
END
```

```

*****
*   THESIS RESEARCH : FUNCTION MINIMIZATION 4TH ORD SYS   *
*   THIS PROGRAM MINIMIZES THE COST FUNCTION, THE INTEGRAL*
*   OF ERROR SQUARED PLUS A WEIGHTING FACTOR TIMES THE   *
*   CONTROL EFFORT SQUARED AND RETURNS THE FEEDBACK     *
*   GAINS REQUIRED TO MINIMIZE THIS COST FUNTION.        *
*****
*
D      COMMON/HANDJ/FLAG,COST,K0,K1,K2,K3
TITLE  MINIMIZATION OF INTGRL(E**2+Q*U**2),4TH ORD SYSTEM
*
* X(1) = K0, X(2) = K1, X(3) = K2, X(3) = K3
CONST  IC0=0.,K00=793.83674 , K10= 87.119566,K20=4.0852083
CONST  K30 = .093384059
CONST  Q = 1.0E-06
INITIAL
      IF(FLAG.GE.0.0)GO TO 5
      K0 = K00
      K1 = K10
      K2 = K20
      K3 = K30
5     CONTINUE
      FLAG = FLAG + 1
*
*
DERIVATIVE
      R = 1.0 * STEP(0.0)
      E = R - OUTPUT
      M1 = K0 *E - K3 * X3D
      I = M1 - K2 * X2D
      U = I - K1 * XD
*
      X4D = U * 493.1 - 17 * X3D - 84 * X2D - 108 * XD
      X3D = INTGRL(IC0,X4D)
      X2D = INTGRL(IC0,X3D)
      XD = INTGRL(IC0,X2D)
      OUTPUT = INTGRL(IC0,XD)
      FCNER = E**2+Q*U**2
      E1 = INTGRL(IC0,FCNER)
CONTROL FINTIM = 3.0
TERMINAL
      COST = E1
END
STOP
*
*
FORTRAN
* INITIALIZATION OF PARAMETERS FOR HOOKE SUBROUTINE
  IMPLICIT REAL*8(A-H,O-Z)
  DIMENSION X(4),STEP(4),Q(4),QQ(4),W(4)
  STEP(1) = .01
  STEP(2) = .001
  STEP(3) = .001
  STEP(4) = .0001
  N = 4
  ITMAX = 500

```

```
CFTOL = .000001
ALPHA = 2.0
BETA = 0.5
IPRINT = 0
MINMAX = -1
CALL HOOKE(X,STEP,N,ITMAX,CFTOL,ALPHA,BETA,CF,Q,QQ,W,
1IPRINT,MINMAX)
STOP
END
```

```

*****
*   THESIS RESEARCH: UNIT STEP RESPONSE 4TH ORDER SYSTEM   *
*   THIS PROGRAM PRODUCES THE UNIT STEP RESPONSE FOR THE   *
*   MINIMIZED SYSTEM DESIGN AND THE BUTTERWORTH DESIGN.   *
*****
*
*
TITLE: BUTTERWORTH,MINIMIZED SYSTEM UNIT STEP RESPONSE
*
INCON  ICO = 0.0
PARAM  KO = 99.482787 ,K1 =17.718436 ,K2 =1.45109580
PARAM  K3 = .49327812E-01,W0 = 14.89,Q = 0.0001
*
DERIVATIVE
      R = 1.0*STEP(0.0)
      EB = R-BUT
      EM = R-MIN
*
* BUTTERWORTH DESIGN FROM STANDARD FORM
      X4B = W0**4*EB-2.6*W0*X3B-3.4*W0**2*X2B-2.6*W0**3*XB
      X3B = INTGRL(ICO,X4B)
      X2B = INTGRL(ICO,X3B)
      XB  = INTGRL(ICO,X2B)
      BUT = INTGRL(ICO,XB)
      EB1 = EB**2
      BCOST = INTGRL(ICO,EB1)

*
*MINIMIZED DESIGN FROM FUNCTION MINIMIZATION
      M1 = EM*KO - K3 * X3D
      I  = M1 - K2 * X2D
      U  = I - K1*XD
      X4D = 493.1 * U - 17 * X3D - 84 * X2D - 108 * XD
      X3D = INTGRL(ICO,X4D)
      X2D = INTGRL(ICO,X3D)
      XD  = INTGRL(ICO,X2D)
      MIN = INTGRL(ICO,XD)
      EM1 = EM**2 + Q*U**2
      MCOST = INTGRL(ICO,EM1)

*
CONTROL FINTIM = 3.00
SAVE .01,TIME,BUT,MIN,BCOST,MCOST
PRINT .1 ,BUT,MIN,MCOST,BCOST
GRAPH (G1,DE=IBM3279,LOGO=N) TIME(UN=SEC),BUT,MIN
LABEL (G1)UNIT STEP RESPONSE 4TH ORDER SYSTEM ,Q =0.0001,W0=14.89
END
*
PARAM W0=19.85,K0=309.94665,K1=41.110310,K2=2.6116583,K3=.072434062
PARAM Q = 0.00001
CANCEL LABEL(G1)
LABEL(G1)UNIT STEP RESPONSE 4TH ORDER SYSTEM ,Q =0.00001,W0=19.85
END
*
PARAM W0=11.15,K0=31.353198,K1=7.4873020,K2=.77970130,K3=.030946171
PARAM Q = 0.001
CANCEL LABEL(G1)

```



```
CABEL(G1)UNIT STEP RESPONSE 4TH ORDER SYSTEM ,Q =0.001,W0=11.15  
END  
STOP
```

```

*****
*   THESIS RESEARCH: UNIT STEP RESPONSE 4TH ORDER SYSTEM.   *
*   THIS PROGRAM PRODUCES SATURATION RESPONSE FOR COMPARISON *
*   OF BODE AND MINIMIZED DESIGNS.                           *
*****
*
*
TITLE: SATURATION STUDY BODE, MINIMIZED SYSTEM DESIGNS, STEP RESPONSE
*
INCON  ICO = 0.0
ARRAY  FN(4),FD(4),PN(1),PD(5)
TABLE  FN(1-4)=811.64,13812.,68248.,87748
TABLE  FD(1-4)=1,240,8375,75000
TABLE  PN(1)=493.1
TABLE  PD(1-5)=1,17,84,108,0
CONST  W0=11.15,K0=31.353198,K1=7.4873020,K2=.77970130,K3=.030946171
CONST  M=1.0 ,Q = .001
*
DERIVATIVE
      R = 1.0*STEP(0.0)
      EBA= R-BODEA
*      EM = R-MIN
      EMA = R-MINA
*      EMB = R-MINB
* BODE DESIGN NO SATURATION
*      UB= TRNFR(3,3,0.0, FN,FD,EB)
*      BODE = TRNFR(0,4,0.0, PN,PD,UB)
*      X1 = EB**2 + Q*UB**2
*      CB = INTGRL(ICO,X1)
*      IEB = EB**2
*      IUB = UB**2
*      IEEB = INTGRL(ICO,IEB)
*      IUUB = INTGRL(ICO,IUB)
* BODE DESIGN WITH SATURATION
      UBA= TRNFR(3,3,0.0, FN,FD,EBA)
      LBUA = LIMIT(-2.00,2.00,M*UBA)
      BODEA = TRNFR(0,4,0.0, PN,PD,LBUA)
      X1A = EBA**2 + Q*LBUA**2
      CBA = INTGRL(ICO,X1A)
      IEB = EBA**2
      IUB = LBUA**2
      IEEB = INTGRL(ICO,IEB)
      IUUB = INTGRL(ICO,IUB)
*
*MINIMIZED RESPONSE NO SATURATION
*      M1 = EM*K0 - K3 * X3D
*      I = M1 - K2 * X2D
*      UM = I - K1*XD
*      X4D = 493.1 * UM- 17 * X3D - 84 * X2D - 108 * XD
*      X3D = INTGRL(ICO,X4D)
*      X2D = INTGRL(ICO,X3D)
*      XD = INTGRL(ICO,X2D)
*      MIN = INTGRL(ICO,XD)
*      E3 = EM**2 +Q*UM**2
*      CM = INTGRL(ICO,E3)
*      IEM = EM**2

```

```

*      IUM = UM**2
*      IEEM = INTGRL(IC0,IEM)
*      IUUM = INTGRL(IC0,IUM)
*
*MINIMIZED DESIGN WITH SATURATION
M1A = EMA*K0 - K3 * X3DA
IA = M1A - K2 * X2DA
UA = IA - K1*XDA
LMUA = LIMIT(-2.00,2.00,M*UA)
X4DA = 493.1 * LMUA - 17 * X3DA - 84 * X2DA - 108 * XDA
X3DA = INTGRL(IC0,X4DA)
X2DA = INTGRL(IC0,X3DA)
XDA = INTGRL(IC0,X2DA)
MINA = INTGRL(IC0,XDA)
E3A = EMA**2
CMA = INTGRL(IC0,E3A)
IEM = EMA**2
IUM = LMUA**2
IEEM = INTGRL(IC0,IEM)
IUUM = INTGRL(IC0,IUM)

*
*
*
CONTROL FINTIM = 2.00
SAVE .01,TIME,MINA,BODEA,CMA,CBA,LMUA,LBUA,IEEB,IUUB,IEEM,IUUM
PRINT .1 ,MINA,BODEA,CMA,CBA,LMUA,LBUA,IEEB,IUUB,IEEM,IUUM
GRAPH (G1,DE=IBM3279,LOGO=N) TIME(UN=SEC),MINA,BODEA
LABEL (G1)STEP RESPONSE 4TH ORDER SYSTEM ,Q =0.001,W0=11.15,L=2
*
GRAPH (G2,DE=IBM3279,LOGO=N) TIME(UN=SEC),LMUA,LBUA
LABEL (G2)STEP RESPONSE 4TH ORDER SYSTEM ,Q =0.001,W0=11.15,L=2
END
STOP

```

```

*****
* THESIS RESEARCH: UNIT STEP RESPONSE 3RD ORDER SYSTEM      *
* THIS PROGRAM PRODUCED THE UNIT STEP RESPONSE FOR          *
* COMPARISON OF BUTTERWORTH AND MINIMIZED DESIGNS.         *
*****
*
*
TITLE: BUTTERWORTH,MINIMIZED SYSTEM STEP RESPONSE,COMPARISON
*
INCON  ICO = 0.0
PARAM W0=17.12,K0=54.906603,K1=5.7501480,K2=.23870600,Q = .0002
PARAM W0=26.72,K0=343.75667,K1=18.415644,K2=.64320603,Q = .000005
PARAM W0=15.96,K0=42.958667,K1=5.2368362,K2=.24983330,Q = .0005
*
*
DERIVATIVE
      R = 1.0*STEP(0.0)
      EB = R-BUT
      EM = R-MIN
*BUTTERWORTH DESIGN
      X3B = W0**3*EB-2.0*W0*X2B-2.0*W0**2*XB
      X2B = INTGRL(ICO,X3B)
      XB = INTGRL(ICO,X2B)
      BUT = INTGRL(ICO,XB)
      EB1 = EB**2
      BCOST = INTGRL(ICO,EB1)
*
*MINIMIZED DESIGN
      I = EM*K0 - K2 * X2D
      U = I - K1*XD
      X3D = 96 * U - 8 * X2D - 12 * XD
      X2D = INTGRL(ICO,X3D)
      XD = INTGRL(ICO,X2D)
      MIN = INTGRL(ICO,XD)
      EM1 = EM**2 + Q*U**2
      MCOST = INTGRL(ICO,EM1)
*
CONTROL FINTIM = 2.00
SAVE .01,TIME,BUT,MIN,BCOST,MCOST
PRINT .1,BUT,MIN,BCOST,MCOST
GRAPH (G1,DE=IBM3279,LOGO=N) TIME(UN=SEC),BUT,MIN
LABEL(G1)UNIT STEP RESPONSE 3RD ORDER SYSTEM ,Q =0.0005,W0=15.96
END
*
PARAM W0=17.12,K0=54.906603,K1=5.7501480,K2=.23870600
CANCEL LABEL(G1)
LABEL(G1)UNIT STEP RESPONSE 3RD ORDER SYSTEM ,Q =0.0002,W0=17.12
END
*
PARAM W0=26.72,K0=343.75667,K1=18.415644,K2=.64320603
CANCEL LABEL(G1)
LABEL(G1)UNIT STEP RESPONSE 3RD ORDER SYSTEM ,Q =0.000005,W0=26.72
END
STOP

```

```

*****
* THESIS RESEARCH: UNIT STEP RESPONSE 3RD ORDER SYSTEM *
* THIS PROGRAM PROVIDES SATURATION RESPONSE FOR BODE AND *
* MINIMIZED DESIGNS FOR COMPARISON. *
*****
*
*
TITLE: BODE, MINIMIZED SYSTEM SATURATION RESPONSE 3RD ORDER SYS.
*
INCON ICO = 0.0
CONST Q = 0.0005
CONST KO = 42.958667, K1 = 5.2368362, K2 = .24983330, W0 = 15.96, M = 1.0
ARRAY FN(3), FD(3), PN(1), PD(4)
TABLE FN(1-3) = 104.17, 833.33, 1250.04
TABLE FD(1-3) = 1.0, 70.0, 1000.0
TABLE PN(1) = 96
TABLE PD(1-4) = 1, 8, 12, 0

*
*
DERIVATIVE
R = 1.0*STEP(0.0)
EB = R-BODE
EM = R-MIN
* EMA = R-MINA
* EMB = R-MINB
*

*BODE DESIGN NO SATURATION
UB = TRNFR(2, 2, 0.0, FN, FD, EB)
BODE = TRNFR(0, 3, 0.0, PN, PD, UB)
X1 = EB**2 + Q*UB**2
CB = INTGRL(ICO, X1)
IEB = EB**2
IUB = UB**2
IEEB = INTGRL(ICO, IEB)
IUUB = INTGRL(ICO, IUB)
* MINIMIZED DESIGN NO SATURATION
I = EM*KO - K2 * X2D
UM = I - K1*XD
X3D = 96 * UM - 8 * X2D - 12 * XD
X2D = INTGRL(ICO, X3D)
XD = INTGRL(ICO, X2D)
MIN = INTGRL(ICO, XD)
E1 = EM**2 + Q*UM**2
CM = INTGRL(ICO, E1)
IEM = EM**2
IUM = UM**2
IEEM = INTGRL(ICO, IEM)
IUUM = INTGRL(ICO, IUM)

*
* BODE DESIGN WITH SATURATION
* UBA = TRNFR(2, 2, 0.0, FN, FD, EBA)
* LBUA = LIMIT(-2.00, 2.00, M*UBA)
* BODEA = TRNFR(0, 3, 0.0, PN, PD, LBUA)
* X1A = EBA**2 + Q*UBA**2
* CBA = INTGRL(ICO, X1A)

```

```

*      IEB = EBA**2
*      IUB = LBUA**2
*      IEEB = INTGRL(ICO,IEB)
*      IUUB = INTGRL(ICO,IUB)
*

```

```

*MINIMIZED DESIGN WITH SATURATION

```

```

*      IA= EMA*KO - K2 * X2DA
*      UA = IA - K1*XDA
*      LMUA = LIMIT(-2.00,2.00,M*UA)
*      X3DA = 96 * LMUA - 8 * X2DA - 12 * XDA
*      X2DA = INTGRL(ICO,X3DA)
*      XDA = INTGRL(ICO,X2DA)
*      MINA = INTGRL(ICO,XDA)
*      E2 = EMA**2
*      CMA = INTGRL(ICO,E2)
*      IEM = EMA**2
*      IUM = LMUA**2
*      IEEM = INTGRL(ICO,IEM)
*      IUUM = INTGRL(ICO,IUM)
*
*

```

```

CONTROL FINTIM = 2.00

```

```

SAVE .01,TIME,BODE, MIN,UB,UM,CB,CM,IEEB,IUUB,IEEM,IUUM

```

```

PRINT .1 ,BODE,MIN,UB,UM,CB,CM,IEEB,IUUB,IEEM,IUUM

```

```

GRAPH (G1,DE=IBM3279,LOGO=N) TIME(UN=SEC),BODE,MIN

```

```

LABEL (G1)UNIT STEP RESPONSE 3RD ORDER SYSTEM ,Q =0.0005,W0=15.96,L=NO*
*

```

```

GRAPH (G2,DE=IBM3279,LOGO=N) TIME(UN=SEC),UB,UM

```

```

LABEL (G2)UNIT STEP RESPONSE 3RD ORDER SYSTEM ,Q =0.0005,W0=15.96,L=NO*

```

```

END

```

```

STOP

```

REFERENCES

1. G. J. Thaler, Notes for EC4320 (Performance Indices, Standard Forms, Cost Functions, Weighting Matrices), Naval Post Graduate School, 1989 (unpublished)
2. S. S. L. Chang, *Synthesis of Optimum Control Systems*, pp. 22-29, McGraw-Hill Book Co., 1961
3. B. Friedland, *Control System Design*, pp. 243-258, McGraw-Hill Book Co., 1986

INITIAL DISTRIBUTION LIST

	No. Copies
1. Defense Technical Information Center Cameron Station Alexandria, VA 22304-6145	2
2. Library, Code 0142 Naval Postgraduate School Monterey, CA 93943-5002	2
3. Chairman, Code 62 Department of Electrical and Computer Engineering Naval Postgraduate School Monterey, CA 93943-5000	1
4. Dr. George J. Thaler, Code 62Tr Department of Electrical and Computer Engineering Naval Postgraduate School Monterey, CA 93943-5000	2
5. Professor Harold A. Titus, Code 62Ts Department of Electrical and Computer Engineering Naval Postgraduate School Monterey, CA 93943-5000	1
6. LT. Joel C. Reaves 533 21st Street N. E. Washington, D. C. 20002	2
7. CPT. Darrel Davis SMC 2025 Naval Postgraduate School Monterey, CA 93943-5000	1

Thesis
R257
c.1

Reaves
Closed loop pole place-
ment and cost analysis.

Thesis
R257
c.1

Reaves
Closed loop pole place-
ment and cost analysis.



thesR257

Closed loop pole placement and cost anal



3 2768 000 87142 0
DUDLEY KNOX LIBRARY