



Calhoun: The NPS Institutional Archive

Theses and Dissertations

Thesis Collection

1992

Tilt-up construction

Crompton, Richard E.

Gainesville, Florida: University of Florida

<http://hdl.handle.net/10945/23792>



Calhoun is a project of the Dudley Knox Library at NPS, furthering the precepts and goals of open government and government transparency. All information contained herein has been approved for release by the NPS Public Affairs Officer.

Dudley Knox Library / Naval Postgraduate School
411 Dyer Road / 1 University Circle
Monterey, California USA 93943

<http://www.nps.edu/library>



TILT-UP CONSTRUCTION

BY

RICHARD E. CROMPTON

A REPORT PRESENTED TO THE GRADUATE COMMITTEE
OF THE DEPARTMENT OF CIVIL ENGINEERING IN
PARTIAL FULFILLMENT OF THE REQUIREMENTS
FOR THE DEGREE OF [MASTER OF ENGINEERING]

UNIVERSITY OF FLORIDA

SPRING 1992

T256878

10000
C 87473
c. 1

TABLE OF CONTENTS

LIST OF FIGURES	iii
CHAPTER ONE - INTRODUCTION TO TILT-UP CONSTRUCTION	1
Definition of Tilt-up Construction	1
Advantages of Tilt-up Construction	1
History of Tilt-up Construction	3
Typical Uses for Tilt-up Buildings	3
CHAPTER TWO - PLANNING THE TILT-UP BUILDING	5
When to Use Tilt-up Construction	5
Will There be Enough Casting Space?	6
Other Considerations for Tilt-up	10
CHAPTER THREE - THE FLOOR SLAB AND CASTING SURFACE	12
The Concrete Floor Slab	12
Cure Coats and Bondbreakers	12
CHAPTER FOUR - CONSTRUCTING THE TILT-UP PANELS	16
Edge Forms	16
Reinforcement	18
Sandwich Panels	18
Lifting Systems and Inserts	20
CHAPTER FIVE - ARCHITECTURAL TREATMENTS	25
Types of Architectural Treatments	25
Exposed Aggregate Finishes	25
Form Liners	27
Rustication and Paint	29
Stucco and Insert Decorative Rocks	30
CHAPTER SIX - RIGGING, LIFTING, AND PLACING TILT-UP	33
Preplanning	33
Rigging for the Lift	33
Making the Lift	39
Plumbing Panels	41
Temporary Bracing	43
CHAPTER SEVEN - CONNECTIONS FOR TILT-UP CONSTRUCTION	48
Design Considerations	48
Types of Connections	49
Foundation Connections	50
Panel to Panel Connections	52
Roof and Floor Connections	54
CONCLUSION	62
REFERENCES	63
BIBLIOGRAPHY	64

LIST OF FIGURES

Figure 1: Panels Placed in Rows	7
Figure 2: Casting Slab for Building with Small Footprint .	8
Figure 3: Typical Panel Layout	9
Figure 4: An Example of How to Form the Edge of a Panel . .	17
Figure 5: Sandwich Panels Have a Core of Insulation Surrounded by Concrete	19
Figure 6: Ground Release Hardware Before Attaching to Panel	22
Figure 7: Ground Release Hardware attached to panel	22
Figure 8: Exposed Aggregate Finishes Can be Cast Two Ways .	26
Figure 9: Typical Form Liner	28
Figure 10: Rustication Used to Highlight Painted Areas . . .	30
Figure 11: An Example of a Panel using Trompe L'oeil	32
Figure 12: Crane Rigged With 4 Rows Across and 2 Rows High .	35
Figure 13: Crane Rigged With 4 Rows Across and 1 Row High . .	35
Figure 14: An Easy Way to Switch From a 3 Hi to a 2 Hi Rigging Configuration	37
Figure 15: Changing From a 4 Hi to a 2 Hi Rigging Configuration	38
Figure 16: Crane Performing a "Suicide Lift" or a "Blind Pick"	40
Figure 17: Crane Operator Can See the Rigging When Panel Lifted This Way	41
Figure 18: Plumbing Blocks Can be Used to Hold a Panel Upright	43
Figure 19: Temporary Panel Bracing	45
Figure 20: Knee Bracing, Lateral Bracing, and End Bracing . .	46
Figure 21: Panel to Foundation Connection	51
Figure 22: Panel to Foundation Connection	52
Figure 23: Rigid and Nonrigid Connections	53
Figure 24: Welded Panel-Panel Connections	54
Figure 25: Recessed Floor/Roof Connection	55
Figure 26: Angle Seat Used to Support Metal Joist	56
Figure 27: Wood Joist Supported on Wood Ledger	57
Figure 28: Wood Beam Supported in Steel Shoe	58
Figure 29: Steel Beam on Pillaster	60
Figure 30: Double Tee on Concrete Ledger	61

CHAPTER ONE INTRODUCTION TO TILT-UP CONSTRUCTION

1.1 Definition of Tilt-up Construction

Tilt-up construction is a special form of precast concrete construction. The technique is used for constructing buildings by prefabricating concrete wall sections (panels) in a horizontal position on either the building's floor slab or on a temporary casting slab. Once the wall sections have cured, they are tilted to a vertical position using a mobile crane, they are temporarily braced in their final upright position, and finally, they are tied into the building's roof and floor system to become an integral part of the finished structure.

Tilt-up is a fast, simple, and economical technique of construction which, in the past, has been used most commonly on one-story buildings. Today, however, buildings as high as six stories are being cast and tilted into position.

1.2 Advantages of Tilt-up Construction

The economic advantage of tilt-up lies in its simplicity and speed of construction. Compared to other forms of precast concrete construction, tilt-up eliminates the need for expensive transportation of building components from the precast plant to the job-site. By casting panels at the project site, panels can be designed much larger than those that must be transported from a precast concrete plant. By

spending time up front in the planning stage of a project, the critical factors of constructing a tilt-up building are carefully considered to minimize total construction time. By applying skillful panel casting layout plans, the panel erection sequence can be accomplished very quickly in an assembly line type operation. Additionally, since the panel erection sequence can be set up to run quickly, the total time required for renting an expensive crane is minimized. Since the panels are cast horizontally at ground level, there is no expensive vertical formwork, and the formwork that is required is accomplished quickly and safely since the carpenters and steelworkers can work at ground level.

Tilt-up buildings are inherently low maintenance since the concrete surfaces can be left unpainted and are not affected by moisture or weathering. Although the typical early generation tilt-up buildings tended to be simple and plain boxlike structures, today's tilt-up buildings have a limitless freedom of design for both shape and architectural treatments. In fact, it is difficult to tell that many recently constructed buildings are made by using the tilt-up technique. Tilt-up buildings can be very flexible since panels can be easily removed and relocated if future building expansions become necessary. Finally, tilt-up panels of 5-1/2 to 6 inches thick have the inherent fire safety rating of concrete buildings and "will provide a fire endurance of two hours or more" (1:3).

1.3 History of Tilt-up Construction

The earliest recorded case of "job-site precasting began as early as 1906 when a railroad bridge, which had been precast [on site], was successfully set in place by a railroad crane" (2:5). Following the first successful use of the tilt-up technique, several small tilt-up structures were built over the next two decades by using tilting platforms or by using railroad cranes. Due to the high expense of laying railroad track for the heavy railroad crane or the expense of constructing the tilting platforms, tilt-up did not catch on as a practical technique until 1946. The significance of this date is simple: modern mobile cranes were developed during the period from 1941-1945 during World War II. After the war, tilt-up construction became a more popular construction technique since panel erection could be rapidly accomplished by the use of mobile cranes.

1.4 Typical Uses for Tilt-up Buildings

Tilt-up construction can be used for any type of low- to mid-rise building. The most common applications are found in warehouses. Warehouse buildings are typically 22 to 30 feet high, they are rectangular in shape, and they have a large floor area. These design aspects of warehouses readily lend themselves to tilt-up construction since the wall heights allow economical panel thicknesses, and the large floor areas provide plenty of room for casting the precast walls. By

using load-bearing tilt-up walls with a light roof system, the needs of a typical warehouse can be realized economically with tilt-up.

Many of today's mid-rise office buildings are constructed using tilt-up. By applying the myriad architectural treatments available, designers can provide buildings that project the professional image desired by any company, and the building can be constructed quickly and economically. A few of tilt-up's most recent markets are in constructing shopping malls, mid-rise apartments, condominiums, townhouses, and hotels.

CHAPTER TWO
PLANNING THE TILT-UP BUILDING

2.1 When to Use Tilt-up Construction

The decision of which method of construction to use for a building is influenced by several factors. The most significant factor is the cost of the building. A building's owner typically will not be as concerned with his new building's construction method as he will be with the building's bottom-line cost. Tilt-up construction is not a technique that a contractor can arbitrarily decide to use on any reinforced concrete structure. The designer must specifically design the building from the very beginning with the intention of having it constructed using the tilt-up method. Since tilt-up panels typically experience stresses from three to four times higher during lifting than they do once they are placed into position, it is extremely important for the designer to consider the critical lifting loads during the design process. The overall cost of the building is going to be controlled by more than just the total material cost. For vertical concrete construction, a major portion of the total building cost can be spent in formwork and labor. If the owner and the designer decide concrete is the material of choice for a building, then tilt-up's potential savings for expensive formwork, labor, and time may become an attractive alternative.

2.2 Will There be Enough Casting Space?

In addition to cost considerations, there are other site dependant considerations that must be weighed. A crowded job-site in an area like New York City would not readily lend itself to using tilt-up construction. The problems with a site that is bordered by other buildings and busy roads are the limited working room for the crane and the limited casting area. It is easy to visualize a building that is relatively tall with a small footprint, and a building with these dimensions in a crowded location cannot economically be constructed using tilt-up since the floor slab is too small to be used for casting the wall panels. Actually, there are two solutions for using tilt-up construction on a project where the building's floor slab is too small for casting wall panels that are tall enough to span from the ground to the roof. One solution is to construct smaller wall panels and then actually place panels on top of each other in their final position as shown in figure 1. The drawback of this system is the difficulty in safely bracing the panels during the construction. The second solution is to construct separate concrete casting slabs on the job site, and then use these slabs for constructing the building's wall panels.

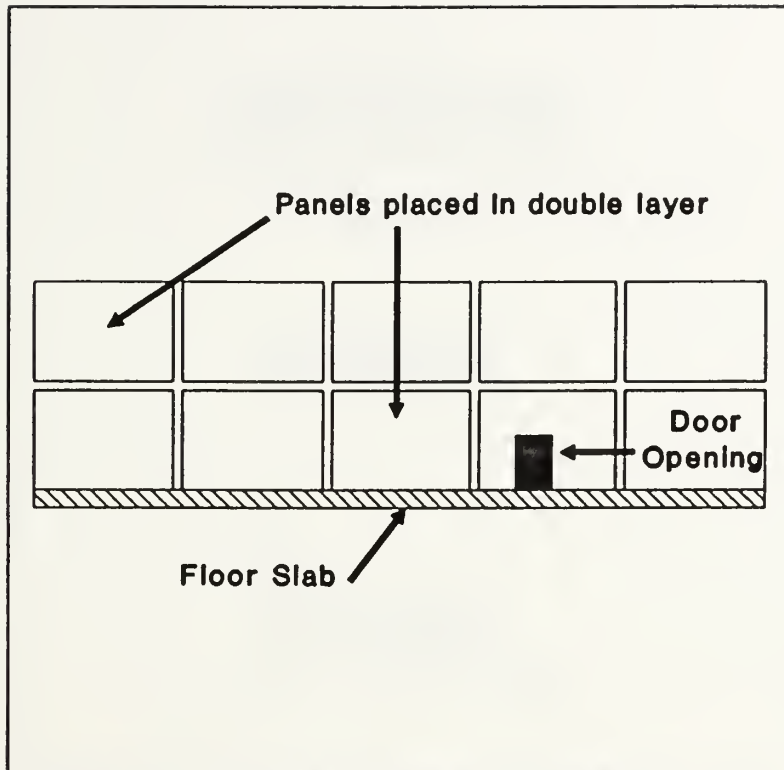

Figure 1: Panels Placed in Rows

To minimize the number of additional casting slabs required, the wall panels can be stack cast on top of each other which means that wall panels are actually poured on top of one another similarly to stacking a deck of playing cards on top of each other one card at a time as shown in figure 2. The major problems with using a separate casting slab are the additional expense required for constructing the additional casting slabs, and the panels are not cast near their final position which means more time and effort must be used to move the panels to their final position along the building's wall.

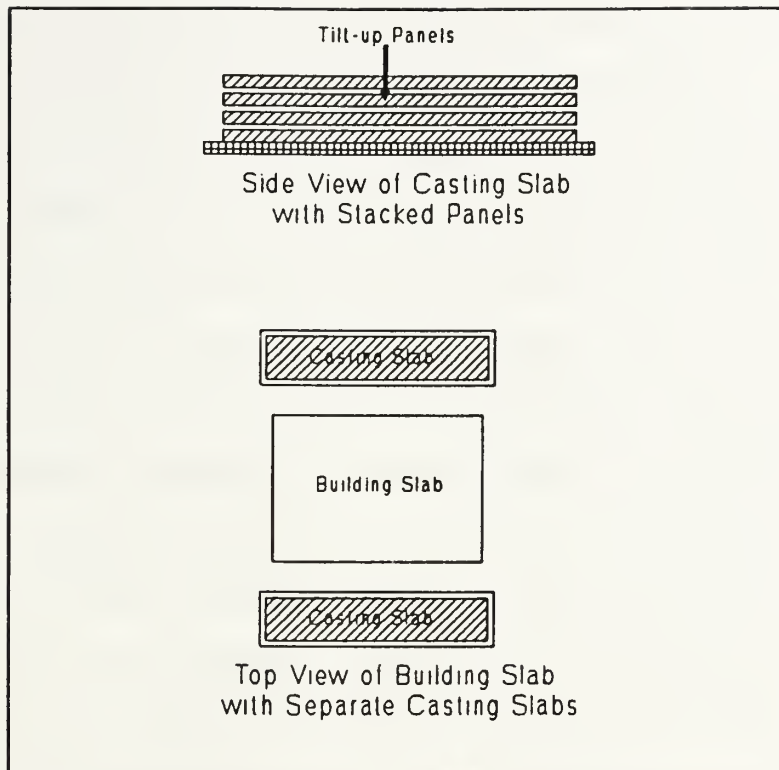

Figure 2: Casting Slab for Building with Small Footprint

A typical tilt-up building will not be affected by nearby buildings or by a floor slab that is too small to be used as a casting bed. For a typical tilt-up building, the floor slab will be constructed first, and then the individual wall panels will be formed and poured directly on top of the floor slab. "A successful tilt-up project depends on proper planning to avoid unnecessary delays and to provide maximum safety. Layout of panels on the casting slab, placement of erection and bracing inserts, movement of the crane, and rigging of the crane to the panel must all be carefully coordinated" (3:23). Figure 3 shows a typical layout for tilt-up panels on a building floor slab. The panels are cast as close to their

final upright position as possible to make the actual lifting operation as quick and efficient as possible. A few items need to be considered while planning the layout for casting the wall panels. It is critical to leave a space along the edge of the building slab to allow the crane access to the middle portion of the floor slab when the crane arrives to lift the panels. This is not necessary if the panels will be lifted from the outside of the building, but usually the crane will lift panels from the inside of the building to take advantage of the firm operating surface of the floor slab. Corner panels are usually stack cast on top of each other to keep them as close as possible to their final position. Finally, any overhead power lines, adjacent construction, or weak areas in the slab must be considered before the lifting can safely begin.

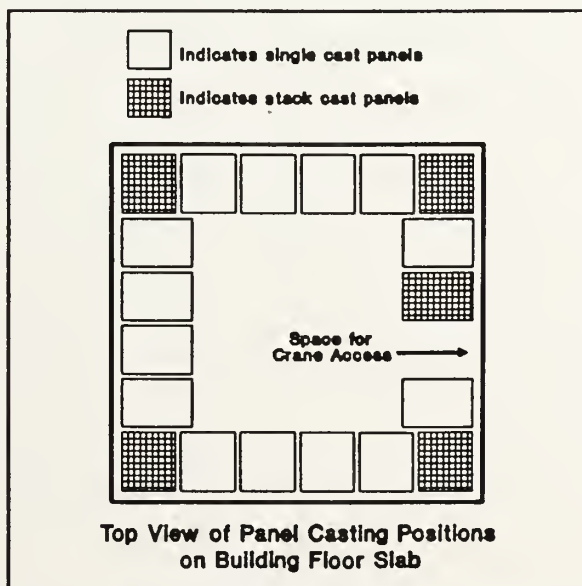

Figure 3: Typical Panel Layout

2.3 Other Considerations for Tilt-up

There are many items that must be considered when planning a tilt-up building in addition to site location considerations and panel layout. When the panels are being cast on either the floor slab or the casting bed, a bondbreaker must be used to keep the concrete panels from sticking to the casting surface. Also, most panels are poured with the exterior face down, so any architectural treatments for the outside of the building must be placed as part of the panel forming process before the concrete is poured. A critical part of all tilt-up projects is the exact location of the inserts that will be used for attaching the crane lines to the panel. Today, the required number and location of inserts required to safely lift tilt-up panels are almost always determined by computer analysis. The designer, however, must have an idea of where the lifting points should be located beforehand since computer solutions are not infallible. The crane company that will be used to perform the lifting should be consulted before the project begins. In addition to preparing the proper sling configurations for the job, the crane experts can provide valuable advice on organizing a particular job-site to minimize expensive crane time.

After the panels are poured and lifted into place, each panel must be temporarily braced to safely hold it in a vertical position. The bracing is a very critical part of every tilt-up project because the crane cannot release a panel

until the panel is properly braced. Obviously, proper planning for bracing the panels can significantly affect the savings on a tilt-up project. Tilt-up panels can be either welded or cast into the buildings footer, and both the type of connection and the timing of connecting the panels to the footer must be considered.

The final items that need to be considered on a tilt-up building are the connections between adjacent panels and the design of the buildings roof. These two items are particularly important because they both give a tilt-up building its structural integrity. In particular, these connections must be capable of withstanding fires, because the building panels can collapse and cause additional damage if the connections fail due to a fire.

CHAPTER THREE THE FLOOR SLAB AND CASTING SURFACE

3.1 The Concrete Floor Slab

Typically, the wall panels are cast directly on top of a tilt-up building's floor slab, so the floor slab must be constructed with great care. The floor slab should be level, and since the slab will become the form for the exterior face of the walls, any faults or imperfections will be identically reflected on the wall panels. The fabrication of a proper floor slab always begins with the subgrade. "The subgrade must provide non-sagging support for the concrete slab. Because the floor slab must bear the weight of the heavy panels and the mobile crane, it is important that it be well supported at all points by a thoroughly compacted subgrade" (4:15). Typical tilt-up building concrete floor slabs range from five to six inches thick. In addition to strength considerations, the quality of the finished surface is very important. Proper vibration, screeding, finishing, and curing are essential to provide an adequate casting surface.

3.2 Cure Coats and Bondbreakers

"One of the least considered items...can also be one of the most important and is crucial to a successful tilt-up project. That is the type, use, and application of the curing compound and bondbreaker" (3:16). Since concrete tilt-up panels will "mirror" the finish on the floor slab, a proper

curing process for the floor slab is extremely important. Properly curing the floor slab will prevent cracks and other imperfections that may occur on the casting surface due to improper rates of hydration. Equally important as the use of a proper curing compound for the slab is the use of a bondbreaker between the slab and the concrete tilt-up panels to allow the panels to break free of the slab without any adhesive forces being developed. A tilt-up panel poured directly on a concrete floor slab without a bondbreaker would adhere to the slab and could not be lifted. The common practice for curing compounds and bondbreakers is to use one compound that will perform both functions. The American Concrete Institute recommends using a combined curing agent and bondbreaker to insure "compatibility between these materials and [to] eliminate the possibility of the wrong product being used for either one of the functions" (3:16). Under extreme conditions such as hot, windy conditions where the maximum curing efficiency would be required to limit hydration, separate chemicals may be required to obtain the required curing effect. Whenever a separate curing compound and bondbreaker are used, the manufacturer of the bondbreaker should be consulted to ensure the bondbreaker will still be effective when used in conjunction with the different curing compound.

Curing compounds and bondbreakers are simple to apply. The curing compound should be applied to the floor slab as soon as the final finish work is completed. Since the final strength and surface quality of the floor slab are dependant on the maximum moisture retention, the curing compound should be applied thick enough to form an impenetrable water barrier to hold in moisture. Once the floor slab has cured and construction of the tilt-up panels has begun, the bondbreaker coat should be applied after the panel edge forms are set and before placing the panel's reinforcing steel and lifting inserts. Typical coverage for the bondbreaker ranges from 350 to 400 square feet per gallon. "Coverage may be tested by sprinkling water on the surface. Water should bead up. If it spreads and soaks in, an additional light application is indicated. Avoid over application. Do not spray the bondbreaker on inserts or reinforcing steel" (4:22).

The following are several factors that need to be considered when selecting a curing compound and bondbreaker:

- The bondbreaker should be placed on a clean and dry surface. Rain, excessive heat, and dirt may diminish the bondbreaker's effectiveness. Some manufacturers produce bondbreakers that are specifically designed for adverse conditions, and these special compounds should be used when necessary.

- Some bondbreakers oxidize quicker than others, and their effectiveness is diminished shortly after being exposed to the elements. If there will be long delays between the bondbreaker application and the pouring of panels, a bondbreaker resistant to the elements should be chosen.
- Will the panels be painted? Some bondbreakers leave a residue on the tilt-up panels, and this residue must be removed before paint can be applied. If the panels will be painted, it is important to use a bondbreaker that will not need any special preparation prior to painting.
- If the wall panels are going to be left exposed, a bondbreaker that will not leave stains on the concrete must be used. Some bondbreakers will leave stains on the panels.
- If floor treatments will be applied to the floor slab after the panels are lifted, a curing compound and bondbreaker that will not leave any residue that will interfere with the bonding of the floor materials must be used.

Any time there are questions concerning the suitability of the casting surface, the curing compound, or the bondbreaker; the manufacturer of the product should be consulted. Once the concrete has been poured, it is too late to ask for assistance.

CHAPTER FOUR CONSTRUCTING THE TILT-UP PANELS

4.1 Edge Forms

Once the casting location of the panels on the building's floor slab has been determined, the panel edge forms can then be constructed. Edge forms are typically constructed out of 2x6 or 2x8-inch lumber. Several different methods can be used to fasten the forms to the floor slab to hold the forms firmly in place. The following techniques are typical for fastening forms to the floor slab:

- Bolts can be drilled into the floor to anchor the forms.
- Nails can be driven into the floor slab using a power actuated tool.
- Edge forms can be placed on wooden plates and then glued to the floor.
- Edge forms can be braced against each other.

Any of the above methods for attaching the panel forms can be used as long as the panels are held securely. Edge forms must be checked for square to ensure the panel is not deformed. Obviously, a deformed panel could be disastrous and more than likely would be unusable. To prevent spalling or marring of the bottom edges of the panel, a 3/4-inch chamfer strip should be placed along the bottom edge of the forms. Since a wooden form will swell if it absorbs moisture, edge forms should be moistened prior to placing the concrete. Doors, windows, or any other opening that will be cast into the panel are

typically formed out of steel. If these openings were cast out of wood, the wood could swell after the concrete is poured, and the forms would be very difficult to remove. Figure 4 shows a typical edge form. All forms should be coated with a bondbreaker to prevent concrete from sticking to the forms.

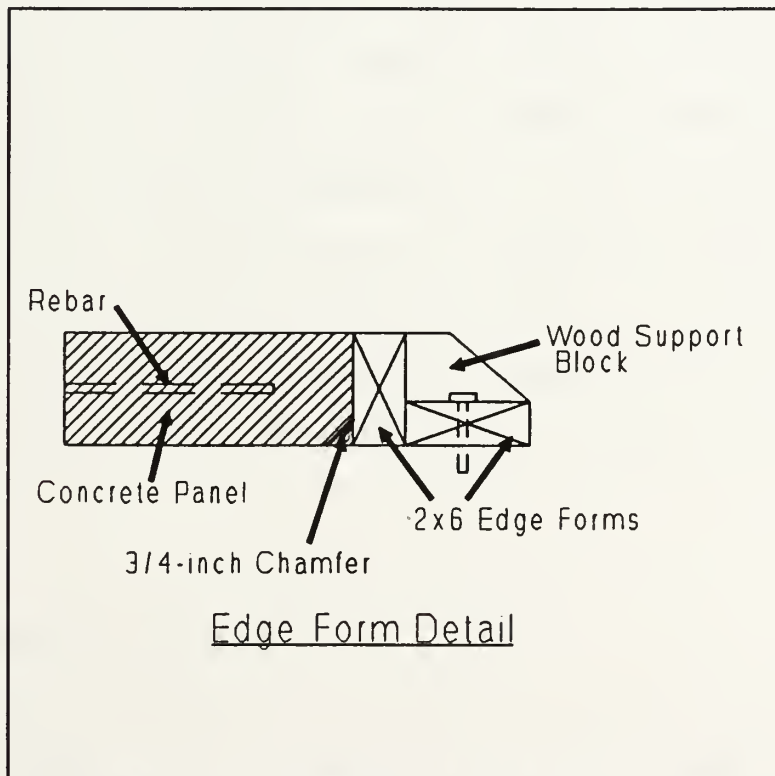

Figure 4: An Example of How to Form the Edge of a Panel

4.2 Reinforcement

Once the panels are formed and squared and the bondbreaker has been applied, the steel reinforcing or "rebar" can be placed inside the forms. Typically, building codes require tilt-up panels to have a steel area of "0.0015 to 0.0025 times the concrete's cross-sectional area" (1:6). A typical panel could be reinforced by No. 4 bars at 12-inch on center for a 6-inch thick panel. This configuration would have a total cross sectional area of 72 square inches per foot, and by multiplying this times 0.0025 yields a required bar size of at least 0.18 square inches. Since a No. 4 bar has a cross sectional area of 0.20 square inches, the typical panel configuration is reasonable. Extra reinforcement is required around openings such as doors and windows. Care must be taken to place the reinforcing steel in the center of each panel. Rebar chairs are used to keep the reinforcing steel off of the casting slab and properly placed in the panel's center.

4.3 Sandwich Panels

"Sandwich panels can be defined as panels which have an inner and outer layer of concrete with some form of insulation in between the two layers. The main advantage of these panels is that they have a low steady-state U-value yet retain the thermal mass properties associated with concrete" (3:59). Figure 5 shows a typical sandwich panel. There are other

options for insulating tilt-up panels: rigid insulation can be attached on the inside of the building and then covered with drywall, or rigid insulation can be glued to the exterior face and then covered with stucco. For energy efficiency, though, interior or exterior methods for insulating tilt-up panels "do not fully use the mass of the concrete in tempering temperature swings" (1:12).

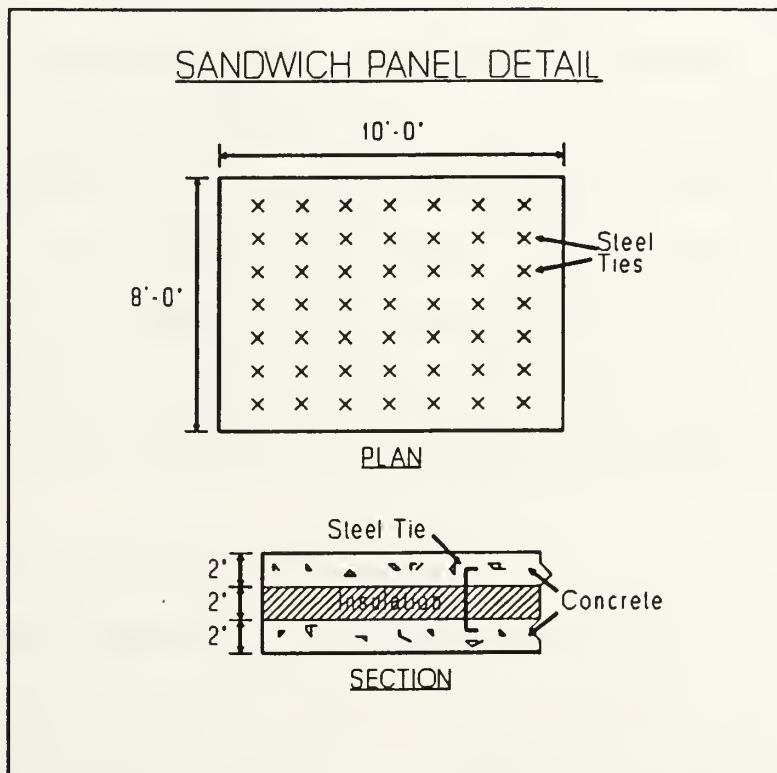

Figure 5: Sandwich Panels Have a Core of Insulation Surrounded by Concrete

"Designers have debated a great deal as to the need to make the two [load-bearing concrete] wythes act as a composite section or to allow them to act independently" (3:62). The debate over using composite or noncomposite construction for sandwich panels is due to concern about cracking caused by unequal thermal movement of the two concrete wythes in the wall panels. If in doubt, the designer should use noncomposite construction where the interior wythe is the load-carrying section, and the exterior concrete wythe is supported by the interior wythe. For noncomposite sandwich panels to effectively dissipate unequal thermal movement, a connection must be chosen that allows the exterior wythe to move independently in response to changes in temperature. In addition, "significant quantities of heat are lost through steel shear connectors [that connect the interior and exterior concrete wythes] due to thermal bridging" (3:65), therefore the steel penetrating the panel's insulation should be kept to a minimum.

4.4 Lifting Systems and Inserts

The most important rule when installing lifting inserts is to follow the manufacturers directions without variation. The consequences of making a mistake at any phase of the lifting insert installation could result in failure of the insert, and the panel could accidentally be released during the lifting operation. The location of pickup points (lifting inserts) should only be done by a qualified engineer.

Constructing panels without the pickup points properly located by an engineer may result in serious safety problems during the erection sequence. Many tilt-up accessories suppliers perform the service of properly locating lifting points. Lifting inserts can be mounted in two locations on a tilt-up panel: they can be located on the face of the panel, or they can be located along the narrow edge of the panel. A vast majority of tilt-up projects are completed using face lift configurations, and this paper will concentrate on face lift construction techniques. Although many manufacturers produce tilt-up panel lifting systems, the lifting systems can be separated into three categories.

The most sophisticated lifting system is the ground release system which uses specialized hardware that connects to the embedded lifting insert and can be detached from the panel by a worker standing at ground level after the panel is erected. The worker simply pulls a quick release line and the lifting line (from the crane) is automatically released from the panel, so the worker does not have to take the time to climb a ladder to disconnect the lifting lines. The advantage of the ground release system is it allows the panels to be connected and disconnected to the crane's lifting lines in the shortest amount of time and thus shortens the time and cost required for keeping an expensive mobile crane on the project site. Figures 6 and 7 below show how ground release hardware attaches to tilt-up panels. The only disadvantage of the

ground release system is it is the most expensive of all available lifting systems.

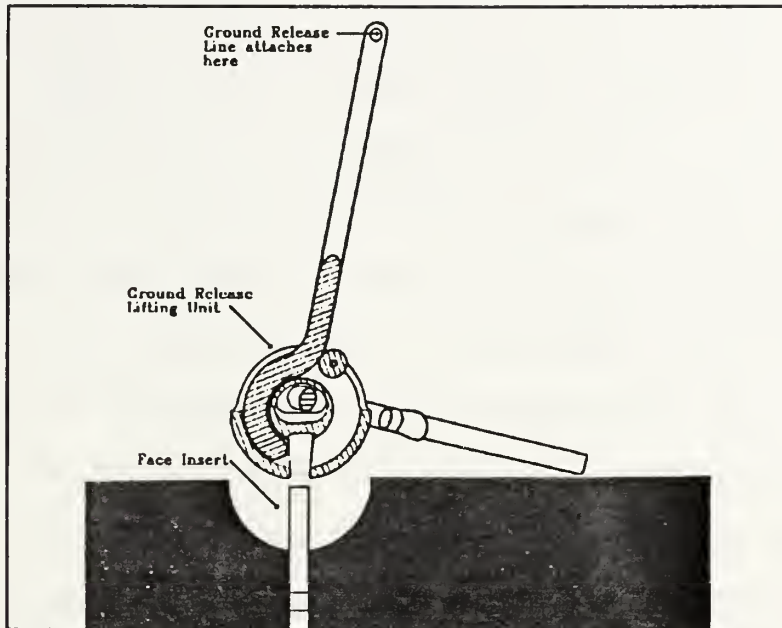

Figure 6: Ground Release Hardware Before Attaching to Panel

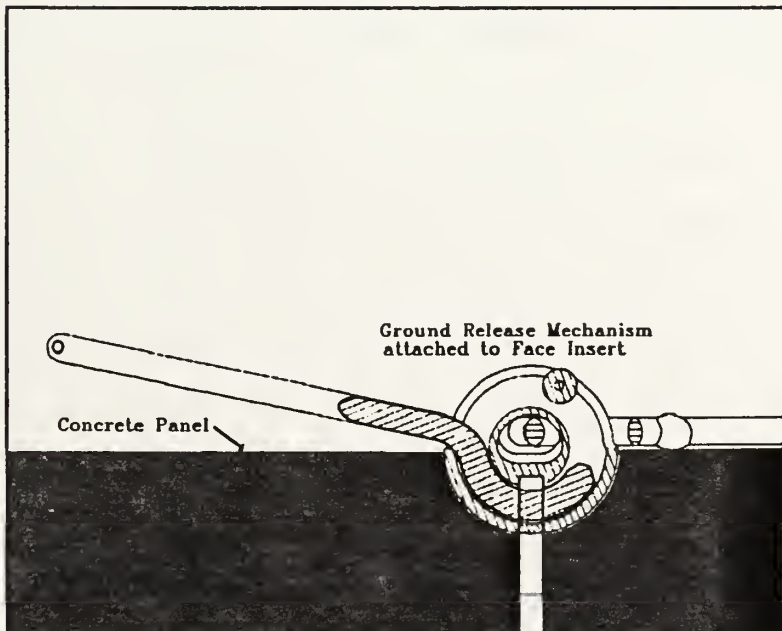

Figure 7: Ground Release Hardware attached to panel

The second lifting system is the twist-lift system. The twist lift system cannot be attached as easily as the ground release system, and the twist-lift systems requires a worker to climb a ladder to detach the lifting lines from the tilt-up panel after the panel has been set in place. The twist-lift system works by simply inserting the twist lift hardware into the embedded insert that is cast into the panel and "twisting" it about a half turn to lock it into position. No tools are required for connecting and disconnecting the twist-lift hardware, so connecting and disconnecting panels can be done relatively fast. When the twist-lift hardware is removed from an erect panel, the crane line actually remains attached to the lifting hardware. The twist-lift hardware is then simply twisted into the next panel, and since the crane lines are still attached to the lifting hardware, the next panel is ready to be lifted.

The least sophisticated lifting system is a simple shackle system that is bolted into a coil insert in the face of the tilt-up panel. The coil insert is cast into the panel, and a swiveling shackle is simply bolted into the insert. The crane line attaches to the swiveling shackle, and each individual lifting point must be attached and released by a laborer using a wrench. The basic shackle system is inefficient due to the large amount of time required for bolting and unbolting each lifting point on every panel.

The main advantage of the simple shackle system is it is the least expensive tilt-up lifting system available.

CHAPTER FIVE ARCHITECTURAL TREATMENTS

5.1 Types of Architectural Treatments

Originally, tilt-up construction was typically very plain and unimaginative when it came to aesthetics. Today, however, tilt-up architectural treatments are only limited by the imagination of the designer. "During the past 25 years, ...we have seen the beginnings of treatments for exterior finishes that are truly pleasing to the eye" (3:3). The earliest attempts at architectural treatments for tilt-up panels were simple exposed aggregate finishes. The concrete industry as a whole has made great strides in their use of architectural treatments over the past couple of decades, and tilt-up construction has directly benefitted from these advances. Today, common treatments include using form liners to produce patterns on the exposed face of the tilt-up panels, using sandblasting or waterblasting with retarders to get exposed aggregate designs, using rustication, using stucco, inseting decorative rocks in the panels, or using paint to produce a "trompe l'oeil" or "fool the eye" finish.

5.2 Exposed Aggregate Finishes

Exposed aggregate finishes can be accomplished by either the face up or the face down methods as shown in figure 8 on the following page. The face up method is accomplished by seeding the desired aggregate into the exposed top of a

freshly poured concrete panel. The aggregate then sets firmly in the concrete as the panel cures. The panel should only require minor cleaning to produce a clean finish.

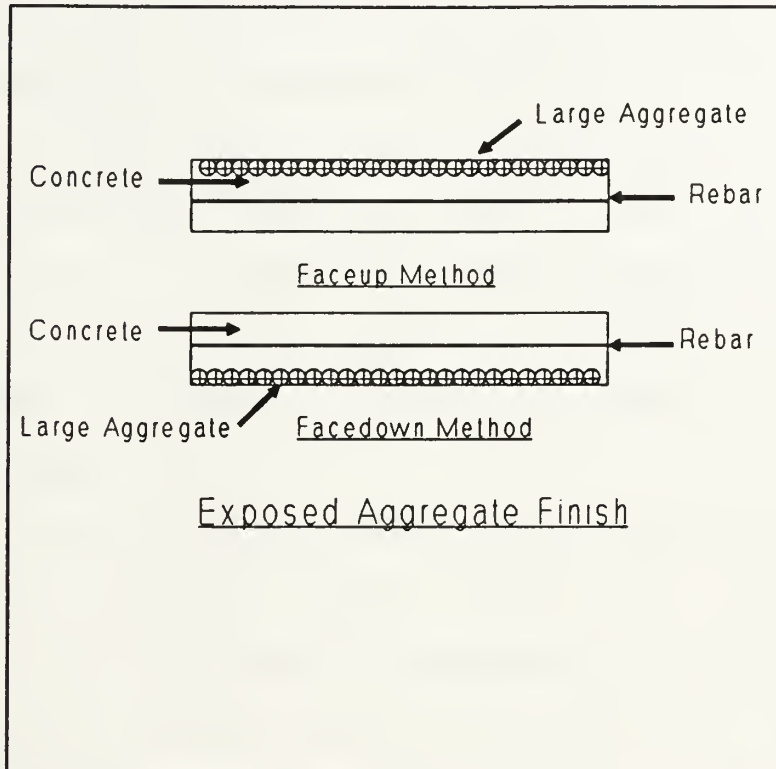

Figure 8: Exposed Aggregate Finishes Can be Cast Two Ways

The major disadvantage of the face up method is the marks from the lifting inserts must be patched after the panel is lifted into place if the panels are lifted with the face lift technique (in this instance, an edge lift system may be desirable). An advantage of the face up method for exposed aggregate finishes is the finish can be controlled to ensure

the aggregates are uniformly and neatly distributed. The face down method for exposed aggregate finishes can be accomplished by placing aggregate in a sand bed at the bottom of a panel before placing the concrete or by using retarders in the concrete and waterblasting or sandblasting the panels after they are lifted into position. The major disadvantage of the face down method is the aggregate finish is not seen until the panels are already lifted, and if there are any areas that were not constructed properly, these areas will not be discovered until it is too late. The face down method lends itself well to face lifts because the exposed face of the panel is left untouched by the lifting inserts.

5.3 Form Liners

Form liners can be made out of many different materials including wood, concrete, plastic, rubber, steel, plaster, and styrofoam. Form liners may be designed for a single use or for many different uses. A common technique for obtaining an interesting architectural treatment is to use molded or carved styrofoam as a form liner. Styrofoam is easily shaped, and it can provide very unique sculptured surfaces on the final tilt-up panels. Figure 9 shows a typical ribbed plastic form liner.

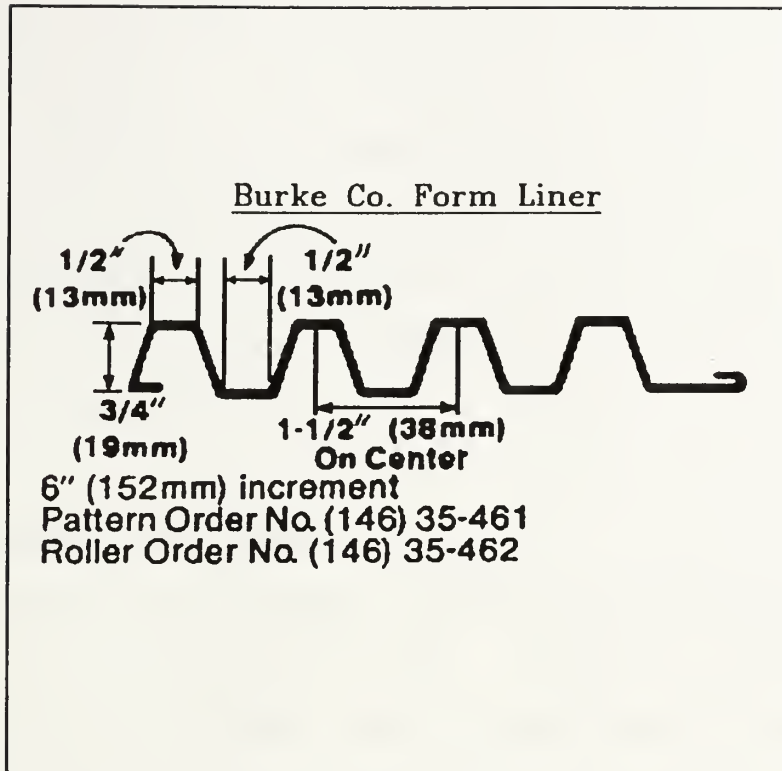

Figure 9: Typical Form Liner

Obviously, styrofoam would be a single use form liner since it does not have the strength to withstand the removal process after the panel is cast. For repeated patterns such as continuous vertical or horizontal ribs, plastic and rubber form liners are very common in today's tilt-up industry. Unlike wood, plastic and rubber form liners leave a smooth imprint, and they come preformed, so they can be simply assembled to fill a tilt-up form very quickly. Additionally, since plastic and rubber form liners are machine made, they assure a uniform reproduction of the desired visual effect over an entire building. With proper care, plastic and

rubber form liners can typically be expected to provide about five to ten reuses. With any form liner, it is important to remember that all joints between sheets of form liners will show in the finished concrete if the liners are not properly sealed. Additionally, as with all tilt-up panels, a quality bondbreaker must be used to prevent the concrete from adhering to the form liners.

5.4 Rustication and Paint

Rustication of any size and shape can be used to impart designs in tilt-up panel surfaces. Typically, wooden strips are used in tilt-up forms to achieve the desired rustication. Often, the rustication is simply a narrow groove about one inch wide used to delineate or separate sections or colors on the tilt-up panel's surface. Figure 10 shows a rustication and paint detail. There is no limit to the different uses for rustication, and any desired design can be constructed in tilt-up panels. As simple as it sounds, paint can be used to provide very pleasant architectural finishes. Often, paint is used in conjunction with rustication to achieve pleasing finishes. It is important to note that only special concrete paints should be used on tilt-up panels to ensure a durable finish.

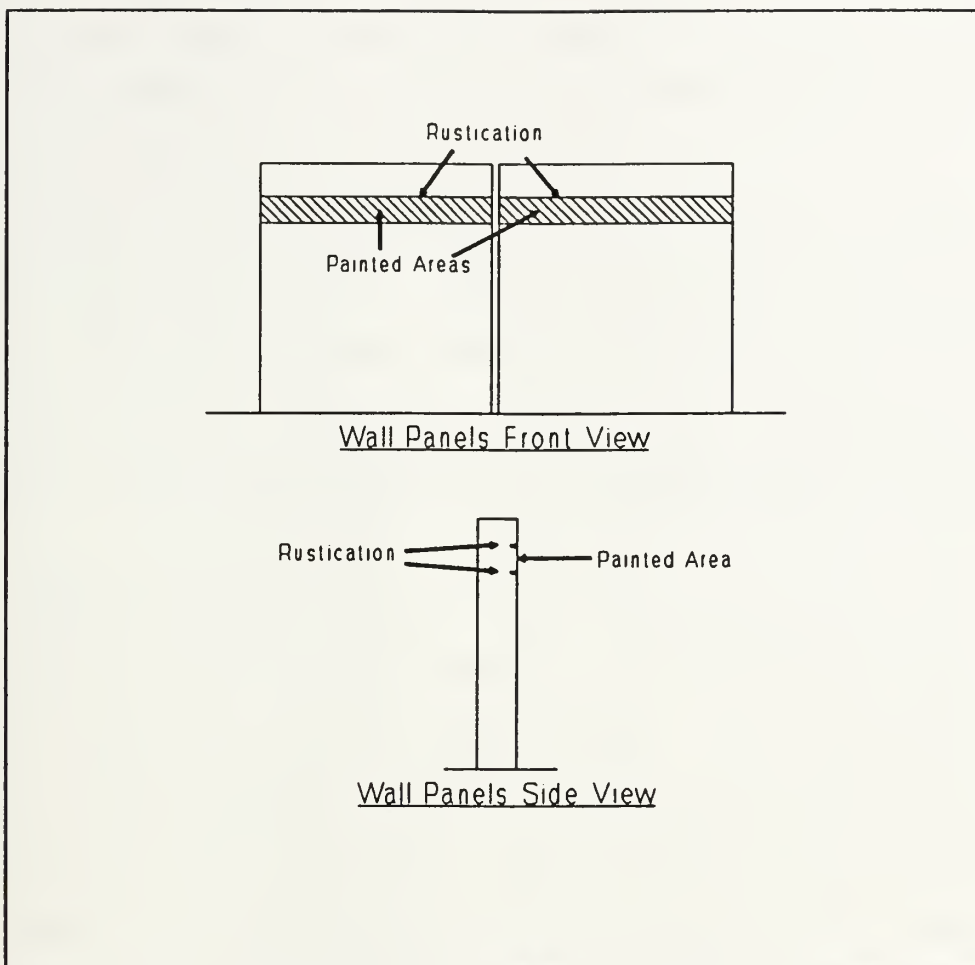

Figure 10: Rustication Used to Highlight Painted Areas

5.5 Stucco and Insert Decorative Rocks

Stucco can be used to provide a very attractive finish for tilt-up buildings. Stucco's textured finish can be used to hide the flat surfaces of tilt-up panels, and stucco can also be used to cover surface blemishes on panels. Also, stucco may be an alternate finish for a contractor who ends up with a tilt-up building with a poor exposed surface; the stucco finish could be applied over the contractor's "mistake"

to provide a final professional appearance. Stucco finishes are very popular in California, and they are becoming more popular in the Southeastern United States.

Insert decorative rocks are similar to a face down exposed aggregate finish. Flat stones are placed on a bed of sand in the tilt-up panel forms, and the concrete is poured over the stones. When the panels are tilted into position, the flat stones are visible on the exposed side of the panel.

5.6 Trompe l'oeil

Trompe l'oeil, or fool the eye, is a technique that lends itself well to tilt-up construction. "By combining the effects of strategically placed rustication strips and the use of various shades of paints, flat tilt-up panels can be made to appear to have depth" (1:10). It is much more cost effective to cast flat panels than to cast panels with deep reveals and textures. Trompe l'oeil combines the economy of flat panels while providing a very attractive aesthetics. Trompe l'oeil lends itself well to tilt-up construction and can be used to give panels the appearance of having recessed windows and recessed doors, and this technique can even be used to make the building appear to have exterior columns or exposed beams. Figure 11 on the following page shows an example of a trompe l'oeil finish.

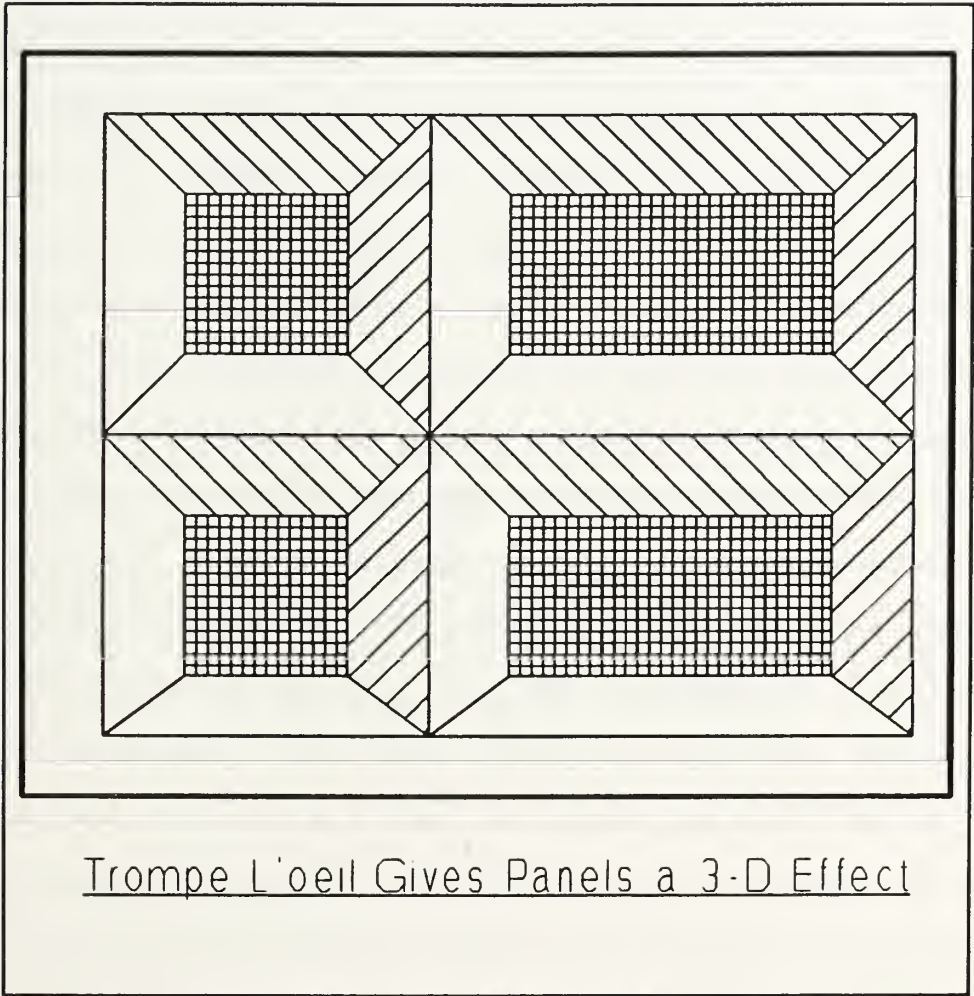

Trompe L'oeil Gives Panels a 3-D Effect

Figure 11: An Example of a Panel using Trompe L'oeil

CHAPTER SIX RIGGING, LIFTING, AND PLACING TILT-UP

6.1 Preplanning

As with any construction project, preplanning is critical for the proper execution of a tilt-up project. A well-designed schedule of operations is essential to provide the proper sequence for erecting the tilt-up panels. As mentioned earlier, a casting layout should be drawn prior to construction to ensure efficient and practical use of space, and the panels should be cast as near their final position as possible. "Recommended practices for quality concrete should be followed to ensure that panels attain a minimum strength of 2500 psi at the time of lifting" (5:13). Based on the lifting system chosen (ground release system, twist-lock system, or simple shackle system), the sequencing of attaching the lift lines, lifting the panels, plumbing the panels, bracing the panels, detaching the lift lines, moving the crane, and removing any form liners must be carefully coordinated. The entire lifting operation must be thoroughly understood by the entire construction crew to allow all phases of the lift to proceed smoothly and efficiently.

6.2 Rigging for the Lift

"As far in advance as possible, the erection contractor, crane supervisor, and rigging supervisor should make a thorough review of crane access to panels, slab thickness,

panel layout, type of lifting connections, and size and weight of panels. It is important to consider potential hazards such as overhead power lines, adjacent construction, or weak areas in the slabs" (3:23). Advance planning for crane rigging is also very important. The rigging configuration will be based on the number and location of the lifting inserts. The recommendations of the design engineer should never be altered or ignored, and the engineer should be consulted prior to making any seemingly simple changes. An important consideration for the lifting contractor is the minimum sling length for the project's lifting configuration. If sling lengths are too short, they can cause excessive side pull on the lifting inserts which may result in failed inserts or cracked panels. The minimum sling length is usually expressed as a function of the distance between the inserts that are connected by a single lifting cable. As an example, "the minimum length of a cable running through a single pulley from bottom to top of the panel [a '2 hi' configuration] is expressed as two times the distance between the panel inserts. In a '4 by 1 hi' configuration, where inserts are located side-by-side, minimum sling lengths are three times the distance between inserts; this minimizes side pull" (3:25). Figure 12 shows a simple "4 by 1 hi" configuration, and figure 13 shows a "4 by 2 hi" configuration.

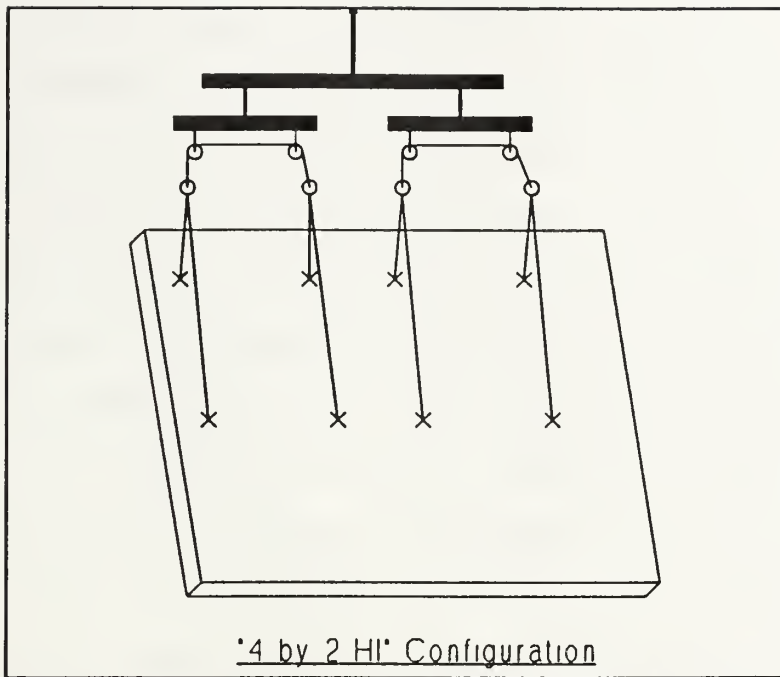

Figure 12: Crane Rigged With 4 Rows Across and 2 Rows High

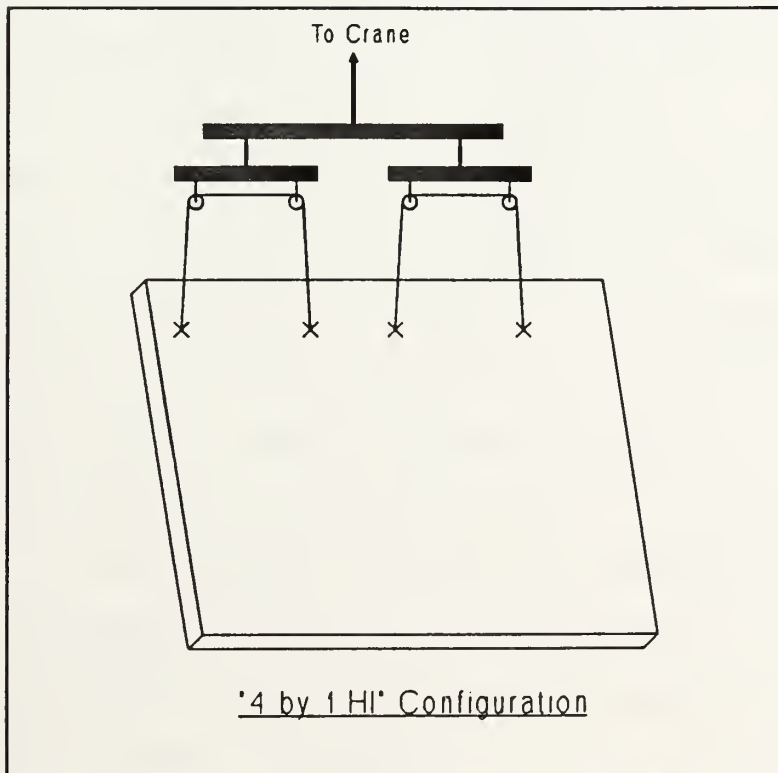

Figure 13: Crane Rigged With 4 Rows Across and 1 Row High

A standard rigging configuration should be chosen in advance and should be used as much as possible without change. Any changes to the rigging configuration should be kept to a minimum to avoid expensive crane delays. It may be economical to add more inserts than required in the lighter panels to keep the rigging configuration consistent with the large heavy panels. The additional cost of a few extra lifting inserts can easily be offset by avoiding expensive crane idle time while waiting for the rigging configuration to be changed. If rigging changes are unavoidable, lifting all panels with the same rigging configuration before changing to another configuration will avoid having to switch back again later. Some rigging changes can be made easier than others, and if altering existing rigging can accomplish the lift without having to change the rigging configuration, the simpler rigging method should be used. Figure 14 shows how to change between "3 hi" rigging to "2 hi" rigging, and figure 15 shows how to change between "4 hi" rigging to "2 hi" rigging. Also, it is important to attach all slings to an individual panel at two or more points, and the slings should be run through pulleys to balance the lifting stresses. For panels that are very tall and the lifting stresses are determined to be too great to be handled by the panel's own strength, a steel beam called a "strongback" can be temporarily attached to the panel to handle the lifting stresses.

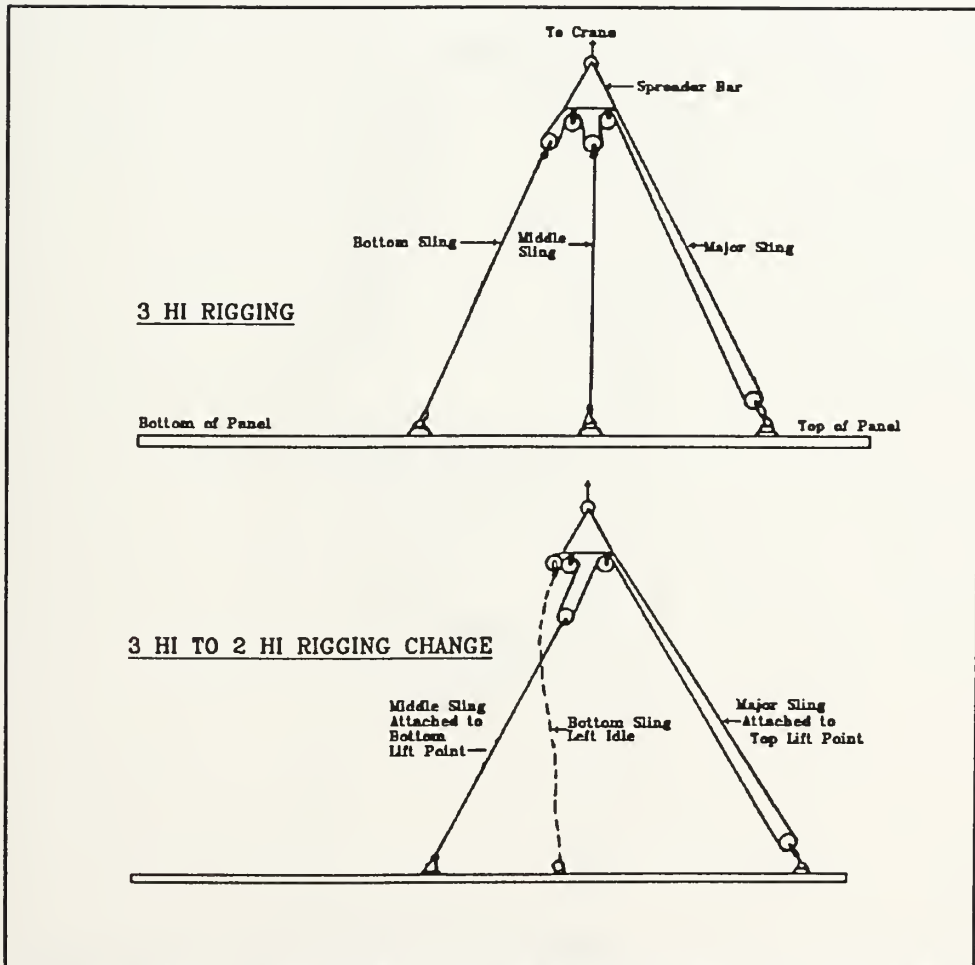

Figure 14: An Easy Way to Switch From a 3 Hi to a 2 Hi Rigging Configuration

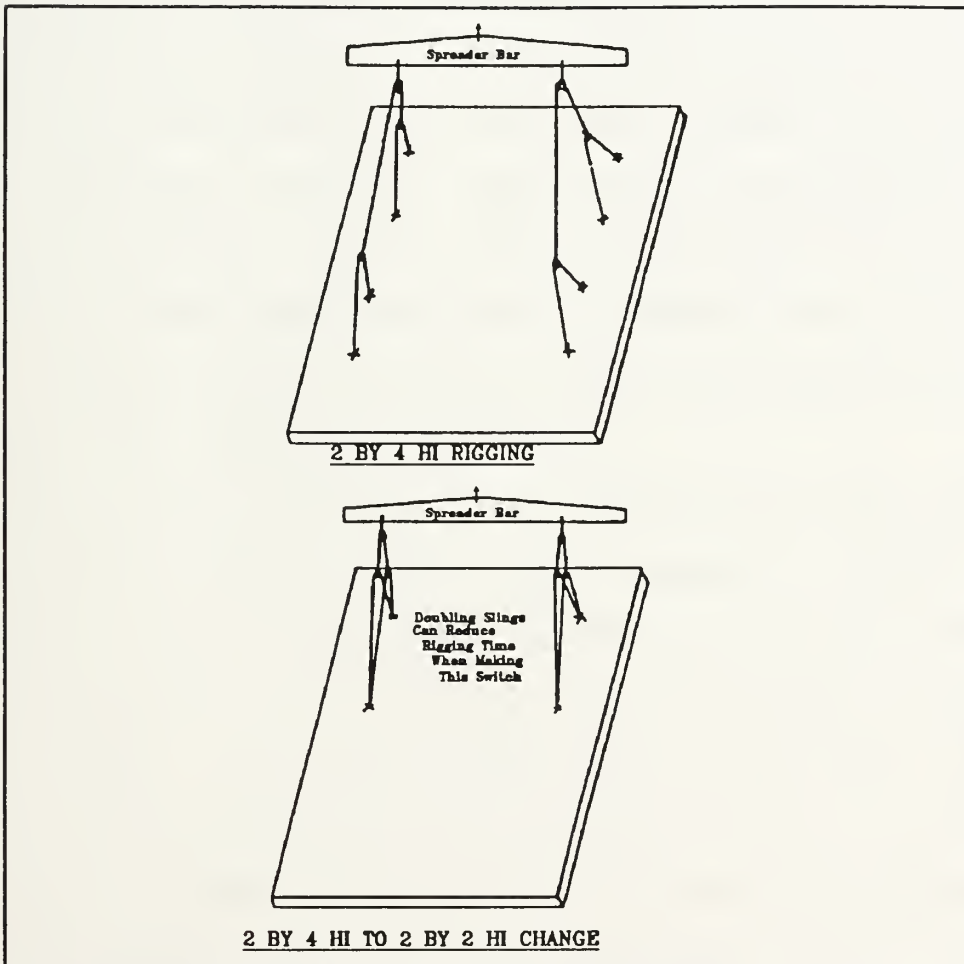

Figure 15: Changing From a 4 Hi to a 2 Hi Rigging Configuration

6.3 Making the Lift

Whenever possible, panels should be lifted with the rigging facing towards the crane. Lifts where the crane is on the opposite side of the panel from where the rigging is attached are called "blind picks" or "suicide" lifts. These types of lifts should be avoided because they do not allow the crane operator to visually check the rigging during the lift. If failure occurs during a suicide lift, the panel will fall towards the crane and could seriously damage the crane or injure the crane operator. There will be times when a blind pick is unavoidable, such as when placing the final panel on a building where the crane must be outside the building to avoid trapping itself in, but the use of blind picks should be used only when absolutely necessary.

"It is best to lift the inside face of the panel from the inside of the building. This allows [temporary] braces to be attached to the panels before lifting so that they can be quickly secured to the floor slab after the panel is set in place" (3:26). Lifting the inside face of the panel from the inside of the building allows the crane operator to see his rigging at all times. Additionally, the floor slab offers the crane a solid platform for operating during lifting operations. If space on the floor slab will be limited, stack casting the panels may provide adequate operating room for the crane. Assuming the crane will not be using blind picks, if the panels are lifted from outside of the building, the

lifting inserts on the panels would end up being visible on the exterior of the building. Also, the temporary braces would need to be attached to the interior face of the panel after the panel was lifted and still attached to the crane; or the braces could be attached to the exposed exterior face prior to the lift, but they would required special anchoring points constructed outside the building. Lifting from the inside face avoids using blind picks, it avoids having the lifting inserts visible on the exterior of the building, and it avoids any crane delays or extra labor to attach the temporary bracing. Figure 16 shows a blind pick, and figure 17 shows the proper technique for lifting panels from inside the building.

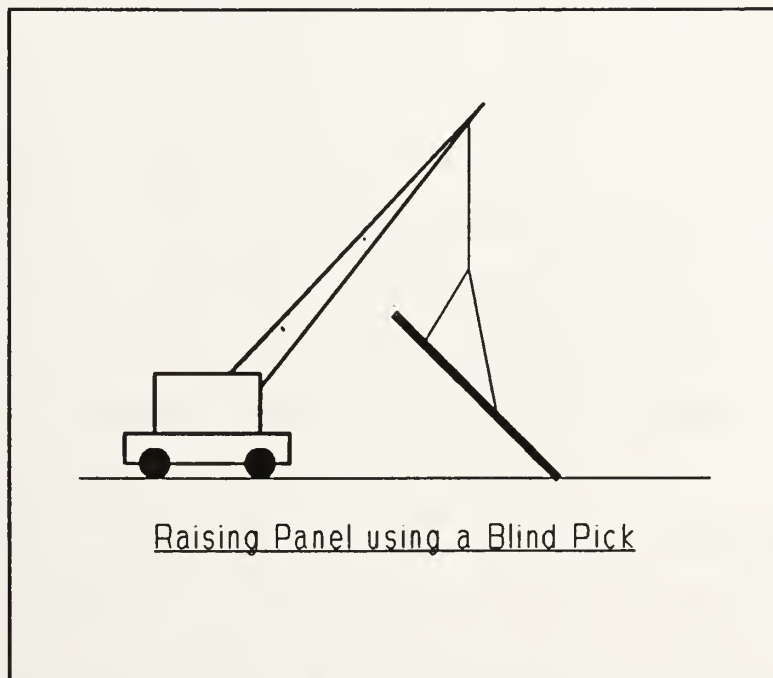

Figure 16: Crane Performing a "Suicide Lift" or a "Blind Pick"

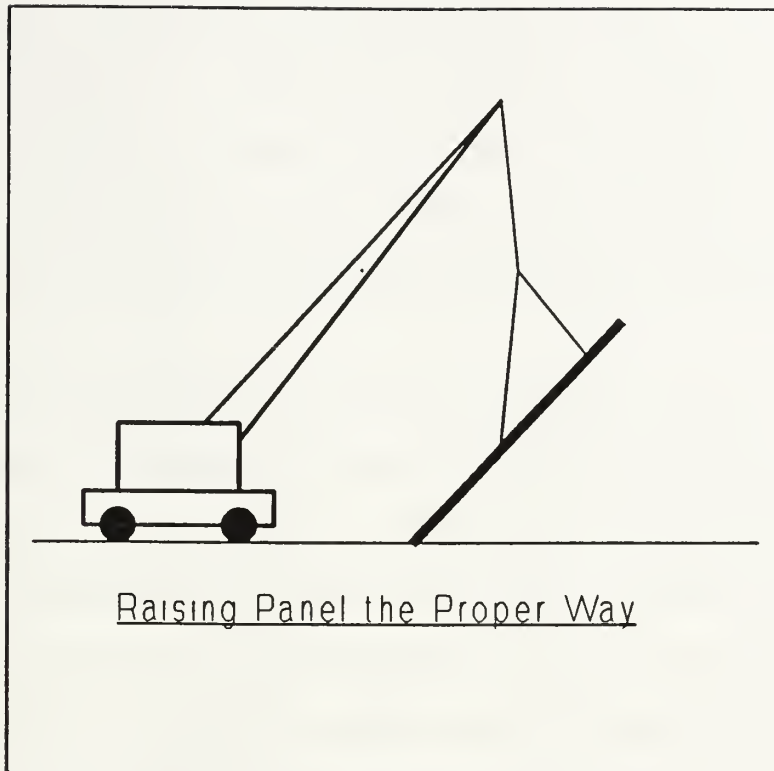

Figure 17: Crane Operator Can See the Rigging When Panel Lifted This Way

6.4 Plumbing Panels

The use of a face lift will cause a tilt-up panel to hang at an angle from vertical. To place the panel, however, it is necessary to have the panel hang straight up and down. There are two techniques for straightening panels during the erection process.

A second crane can be used to pull the panel into a vertical position by using lines attached to edge lift points in the top of the panel. The first crane uses the face lift points to lift the panel, and the load is then transferred to the second crane's lines so that the panel hangs from the edge

lift points. The advantage of using the face lift points to tilt the panel is to reduce the bending stresses during the lift (the bending stresses are highest when edge lifts from the top of the panel are used), and once the panel is upright, it can easily accept the vertical stresses from the edge lift points.

A simple technique that can be used in lieu of using a second crane is to use plumbing blocks to hold the panel in a vertical position. As shown in figure 18, plumbing blocks can be used to counteract the panel's tenency to hang at an angle. Plumbing blocks can be constructed out of 1/4 inch steel plate with a slot long enough to accommodate the panel thickness and the width of the crane sling. To install plumbing blocks, the panel is tilted up with the bottom resting on the ground. The panel is then tipped until the face of the panel is against the lifting sling. The plumbing blocks are then placed around the sling and hooked over the panel to keep the sling from pulling away from the panel. This simple technique will then keep the panel in a vertical position.

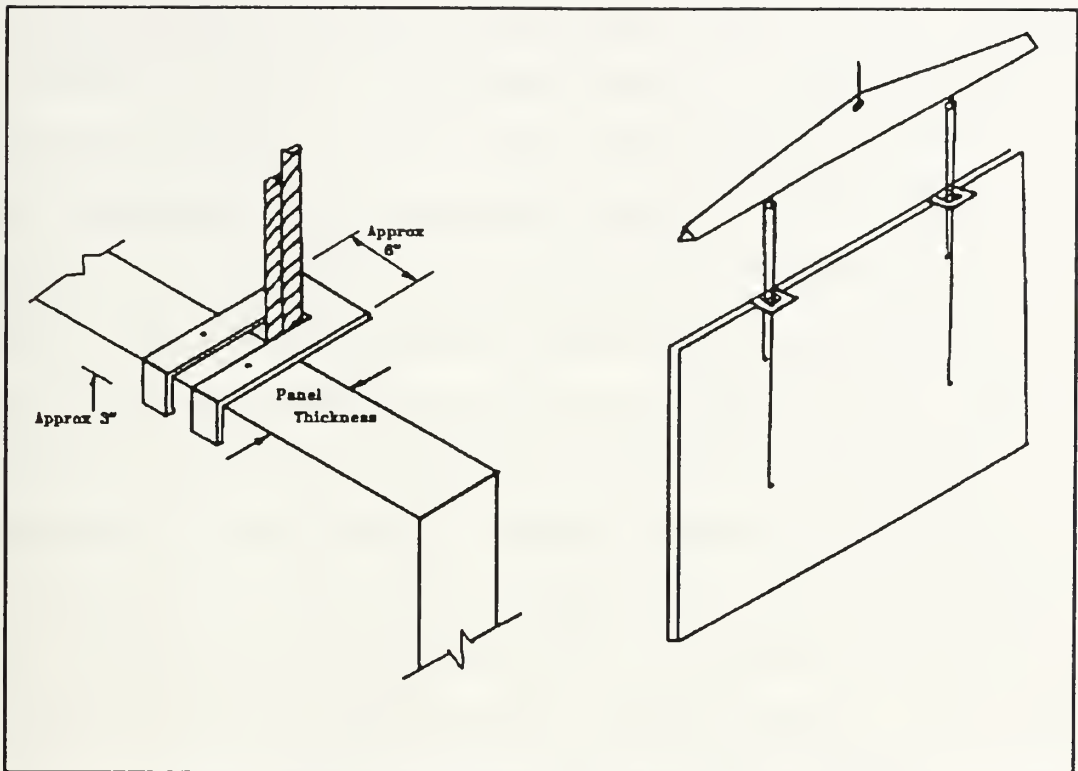

Figure 18: Plumbing Blocks Can be Used to Hold a Panel Upright

6.5 Temporary Bracing

Once a tilt-up panel is set into position, it is not yet a completed wall. An individual panel would be naturally unbalanced due to its tall and narrow shape. Also, wind forces would act on a newly erected panel to attempt to tip the panel. Temporary support in the form of bracing is necessary to keep the newly erected panels from tipping over. In effect, an unbraced tilt-up building would be like a house of cards.

"OSHA recommends that brace strength and spacing be able to withstand a minimum wind load of 10 psf which corresponds to a wind velocity of approximately 48 mph. Local conditions

and local agency recommendations may vary" (4:45). As shown in figure 19 on the following page, a tilt-up brace is generally attached to the wall and building floor slab by bolts threaded into pre-placed inserts. The brace can be attached to the panel before the panel is lifted off of the casting slab. The floor panel connection can be quickly made right after the panel is set into its final position, and this technique allows all temporary bracing connections to be completed at ground level. Typical braces can be adjusted by telescoping the brace in increments of about six inches. Finer adjustments can be made with an adjusting screw system to get the bracing to the exact required length. For taller panels, an additional knee brace must be installed between the main brace and the tilt-up panel. This additional knee brace is used to prevent the main brace from buckling under high wind loads. Additionally, when knee bracing is used, lateral bracing and end bracing must also be used. Knee bracing by itself will only prevent buckling in the vertical plane, but the addition of lateral and end bracing will also protect the main brace from buckling in the horizontal plane. Figure 20 on the following page shows a panel supported by a knee brace system including lateral and end bracing.

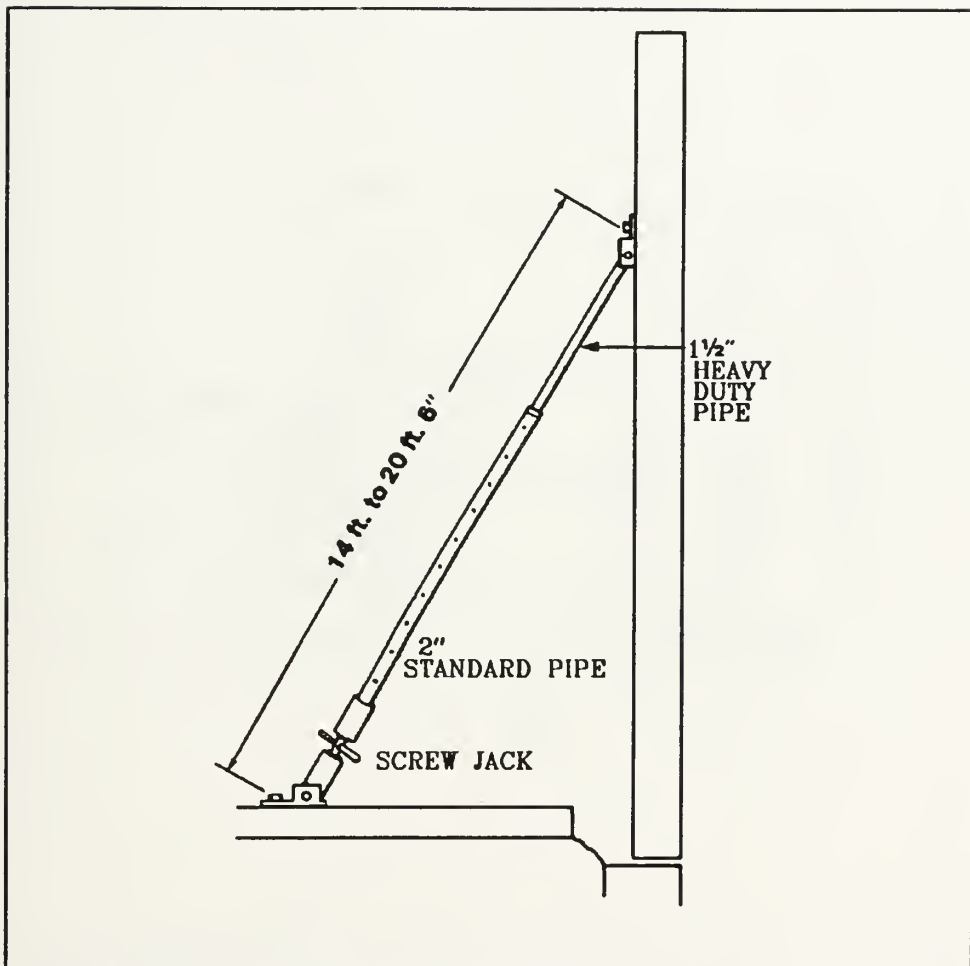

Figure 19: Temporary Panel Bracing

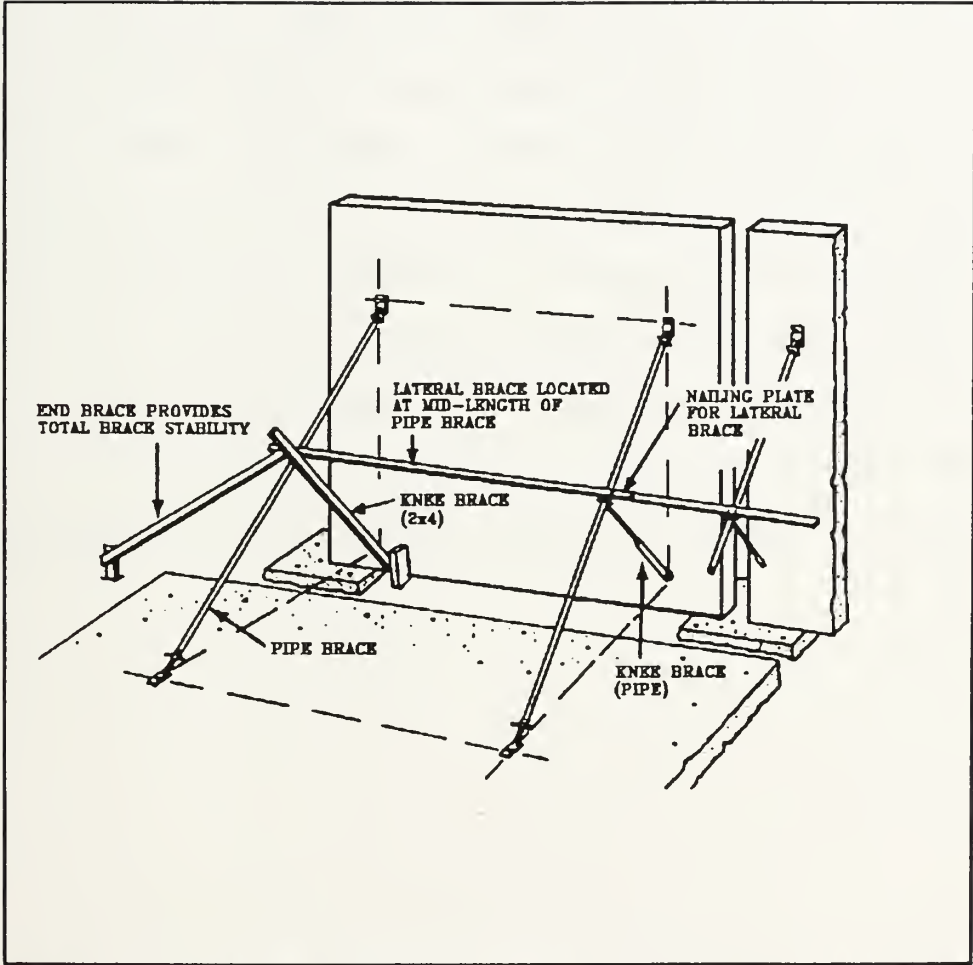

Figure 20: Knee Bracing, Lateral Bracing, and End Bracing

Temporary braces must be attached to the panel above the center of mass to be effective against any overturning forces. The temporary braces should be securely fastened to the floor slab and the wall before the crane rigging is released from the panel. If the crane rigging is released too soon, the panel could fall over and cause significant damage and personal injury. As a common practice, all brace connections should be kept a minimum of one foot from any panel edge, opening, control joint or construction joint to prevent failure of the brace connection. To ensure lateral stability, at least two temporary braces should always be used on each panel. When knee braces are required, the knee must be located at the middle point of the main brace, and the accompanying lateral bracing must be located at this same spot.

CHAPTER SEVEN
CONNECTIONS FOR TILT-UP CONSTRUCTION

7.1 Design Considerations

One of the most important design features of a tilt-up structure is the connections for the foundation, the connections between individual panels, and connections for the roof. The connections are determined by the design engineer, and they are determined based on "strength, ductility, durability, and economy" (5:1). In addition to these four design requirements, fabrication methods and construction time need to be considered. Designs that fail to recognize the importance of connection details on the overall erection plan can cause substantial delays during construction. Usually, the best connection designs are the simplest ones. "By reducing the number of components for a connection, construction economy and efficiency can be enhanced" (5:4). Whenever possible, connections should be optimized to reduce the number of different types of connections. For example, if one connection requires No. 3 reinforcing bar and No. 4 bar is required for another connection, it may be more economical to use No. 4 reinforcing bar on both connections. Anytime the number of different details can be reduced, a savings can be recognized during the construction. Whenever possible, the smallest reinforcing bar size allowable should be chosen to help reduce congestion in the connections. During construction, when embedded structural steel and threaded

inserts are misaligned, delays to construction are inevitable, so it is extremely important to not only ensure good designs but to also ensure good construction practices.

7.2 Types of Connections

Tilt-up panels must not only serve as a building's external cladding, but they must also carry vertical and horizontal loads. To ensure a tilt-up buildings panels can adequately carry the imposed loads, the panels must be adequately designed to transfer the forces from the roof and floor members into the foundations. Also, connections must have ductility to relieve temperature and shrinkage stresses, to relieve seismic stresses, and to minimize cosmetic cracking. Tilt-up connections can be categorized into four main groups: cast-in-place, welded embedded metal, embedded inserts, and drilled-in inserts.

"Cast-in-place connections are made by casting infill sections between the erected panel components with overlapping rebar projecting from the ends of the panel" (3:11). Cast-in-place connections are very strong, but they can be expensive. Since cast-in-place connections are very rigid, the designer must ensure proper attention is given to temperature and shrinkage stress buildup.

The most common type of tilt-up connections are welded embedded metal connections. These connections are constructed by using an anchored embedded steel plate or angle cast

directly into the tilt-up panel, and the exposed surfaces of adjoining elements are field welded. The advantage of the welded embedded metal connections are they are strong enough for most applications, they are fast and inexpensive, and they are fairly ductile.

Embedded inserts and drilled-in inserts allow adjoining elements to be bolted together. Embedded inserts are simply ferrule loops cast into the tilt-up panels, and drilled-in inserts are usually expansion anchors. Both the ferrule loops and the expansion anchors allow bolted connections to be made directly. The advantages of both of these bolted connections are they eliminate the requirement for field welding, and the drilled-in inserts can be used to conveniently correct any slight errors in alignments. Embedded inserts and bolted connections "are the cheapest but least reliable [connections]" (3:12). It is important to note that bolted connections should only be used for connecting nonstructural elements, and they should not be used in buildings subject to seismic loading due to their poor performance under cyclic loading.

7.3 Foundation Connections

There are many variations for tilt-up panel foundations and connections. For panel foundations, it is important to provide connections between the tilt-up panels, the building foundation, and the floor slab. Without connections at the

foundations, panels are subject to displacement due to seismic loads or even from impact by heavy equipment that may operate near the building's walls. Panels are typically connected to the building's footing and floor slab by welding preinstalled metal inserts together, by using grout and dowels to hold the wall panels in place, or by using a cast-in-place concrete connection. Figure 21 and figure 22 show typical wall panel, floor slab, and foundation connections.

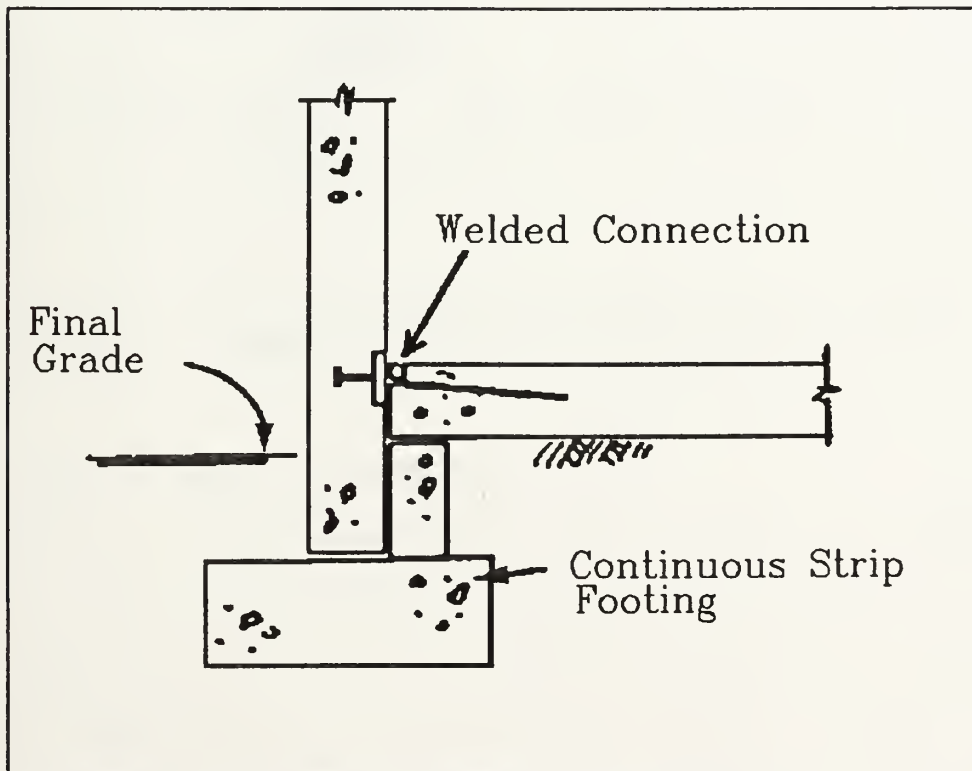

Figure 21: Panel to Foundation Connection

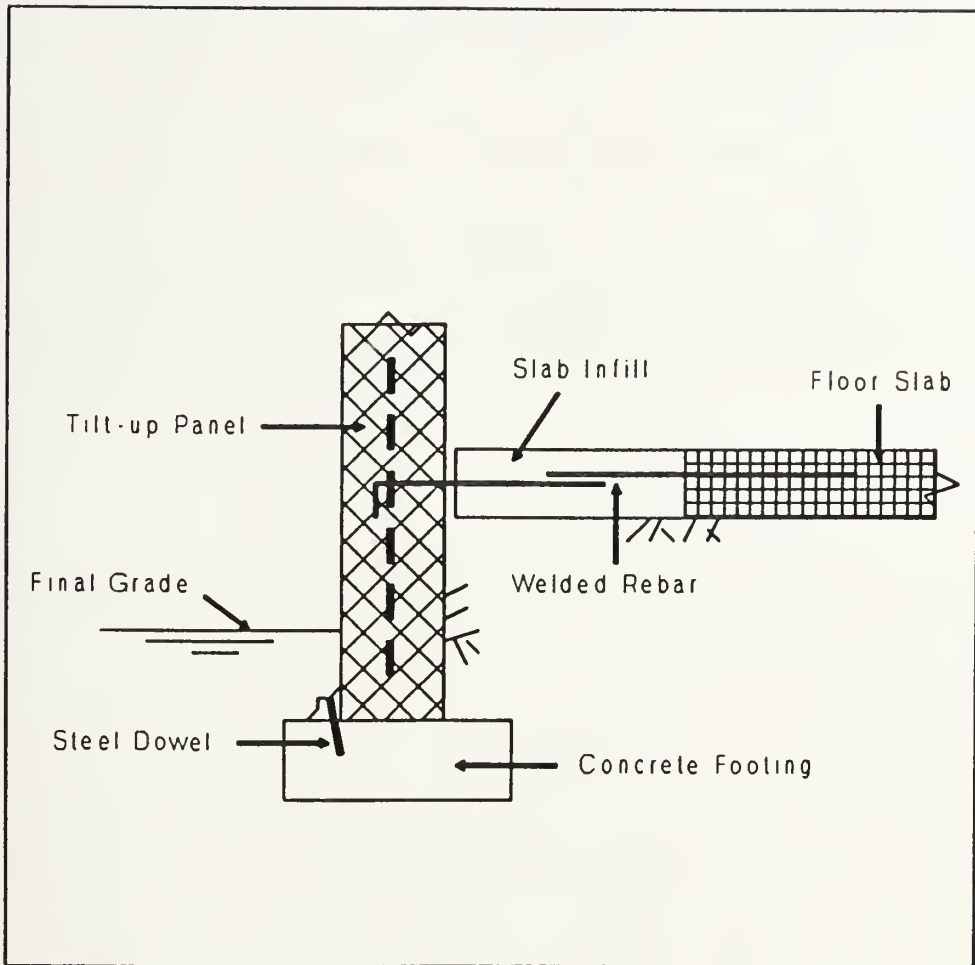

Figure 22: Panel to Foundation Connection

7.4 Panel to Panel Connections

Panel to panel connections must be able to withstand seismic loads and temperature expansion and contraction. The most common panel to panel connections are made from welding together embedded metal inserts in both panels. These welded connections are fast and inexpensive, and they can be designed with enough ductility to allow for seismic and thermal loads. Cast-in-place concrete connections between panels can be used; however their rigidity, high expense, and intensive labor

requirements make cast-in-place connections less popular today than they were in earlier tilt-up buildings. The one exception to this is corner connections; these are still often done using cast-in-place columns to connect adjacent corner slabs. Figure 23 shows both a rigid and nonrigid cast-in-place concrete connection, and Figure 24 shows typical welded panel to panel connections.

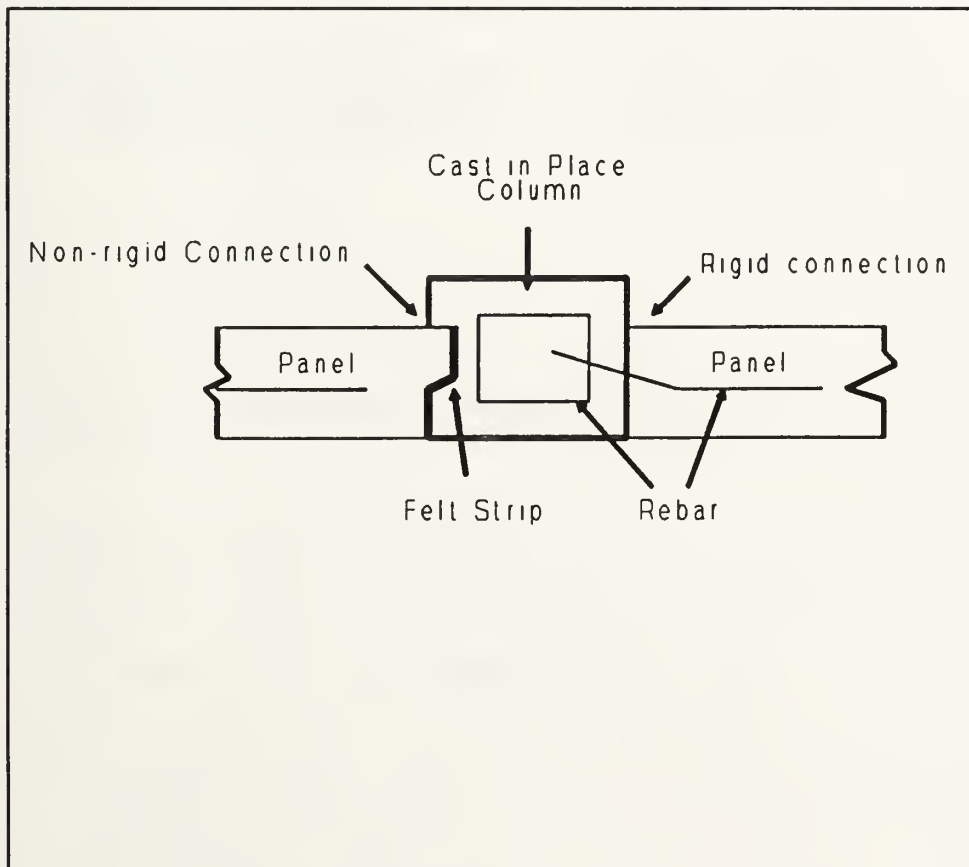

Figure 23: Rigid and Nonrigid Connections

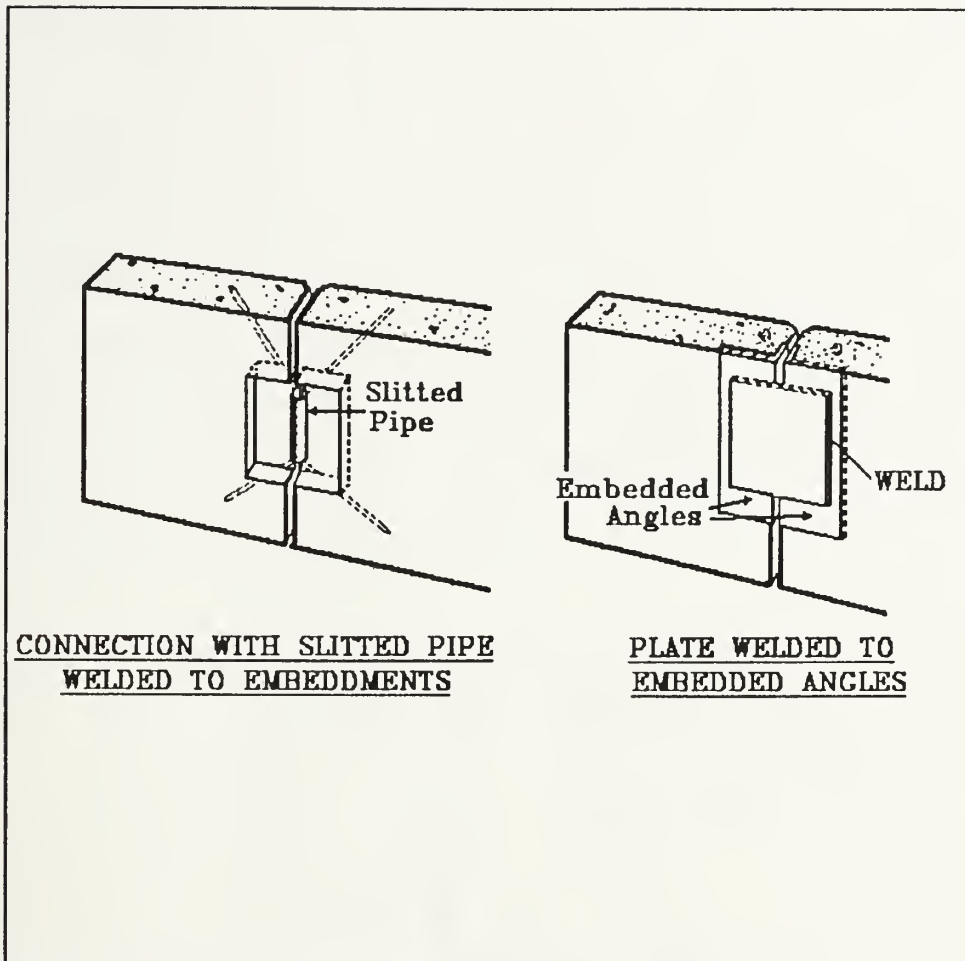

Figure 24: Welded Panel-Panel Connections

7.5 Roof and Floor Connections

There are many ways to detail the connections between tilt-up panels and the upper floors (in a multi-story building) and the roof. The first consideration is going to be the required loading, but another consideration is ease of construction. Two common roof connections are shown in figures 25 and 26 on the following pages. Both of these systems are used for connecting open web joists to tilt-up panels. In figure 25 a pocket is recessed in the panel, and

the steel joist is field welded or bolted to the seat. In figure 26, the angle seat is welded to the embedded steel plate, and the steel joist is then welded onto the angle seat. Once the steel joists are attached to the erected panel, a roof system can be installed. One important similarity between both details shown in figures 25 and 26 is there are no projections above the face of the panel. Using panels with no projections allows for easy screeding and finishing and allows for stack casting panels.

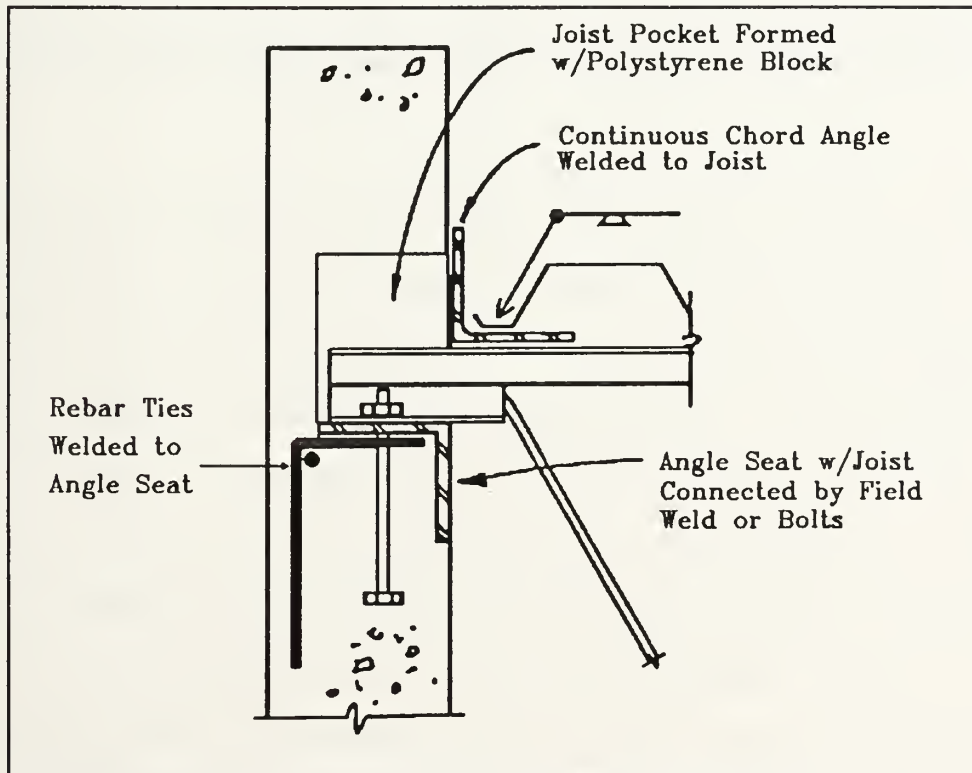

Figure 25: Recessed Floor/Roof Connection

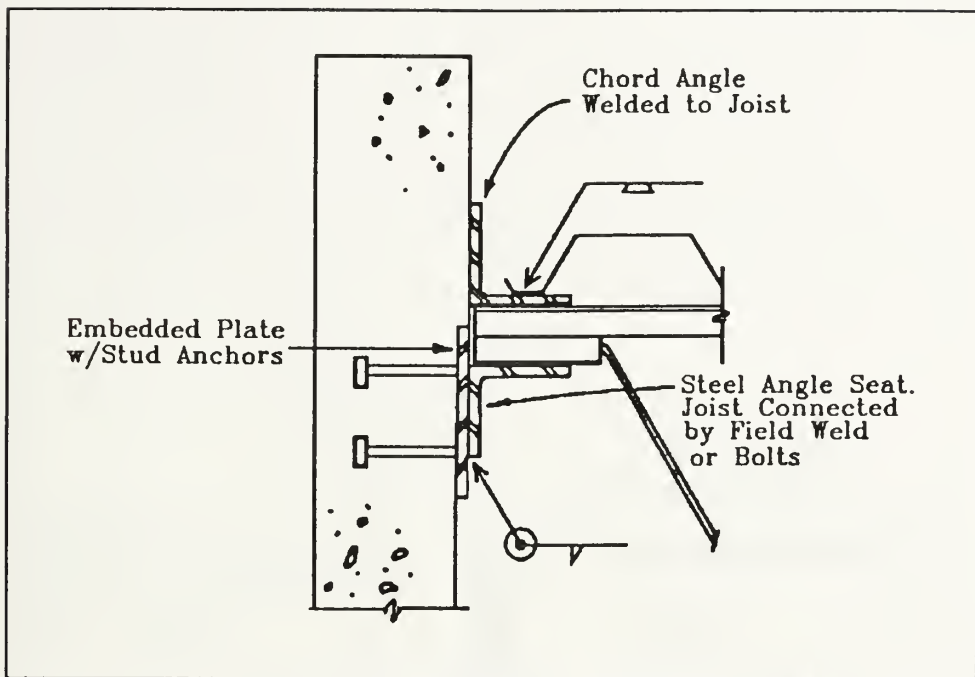

Figure 26: Angle Seat Used to Support Metal Joist

For buildings that will use wood roof or floor construction, there are several ways to connect the wooden members to the tilt-up panels. Figures 27 and 28 show two typical wooden roof or floor connections. In figure 27, a wooden ledger is attached to the panel before erection. The wooden joists are then supported on the ledger as shown. "This is generally sufficient for vertical loads but has been found to be inadequate for transverse seismic loads. It is recommended that transverse steel strap ties be installed to prevent separation of the roof or floor deck from the panel" (3:13). In figure 28, a steel support shoe is used to support a laminated beam, and a system of wooden joists and plywood decking is then placed on top of the beam.

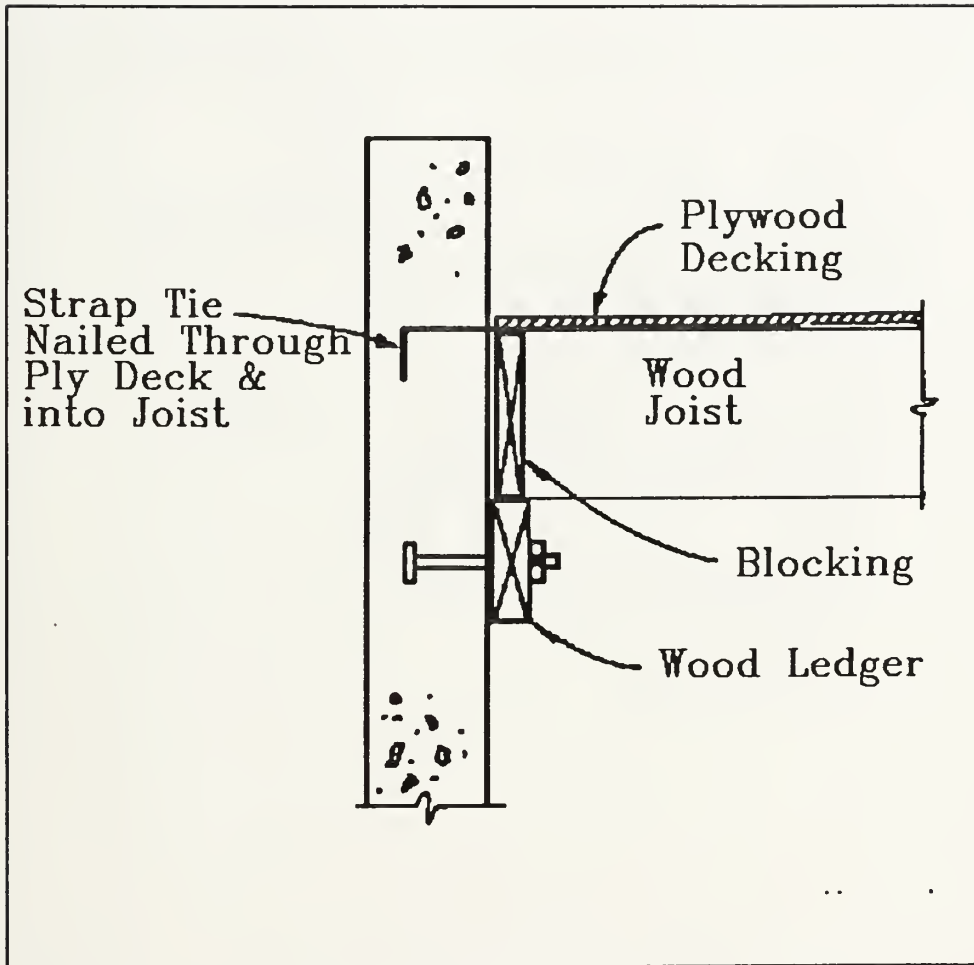

Figure 27: Wood Joist Supported on Wood Ledger

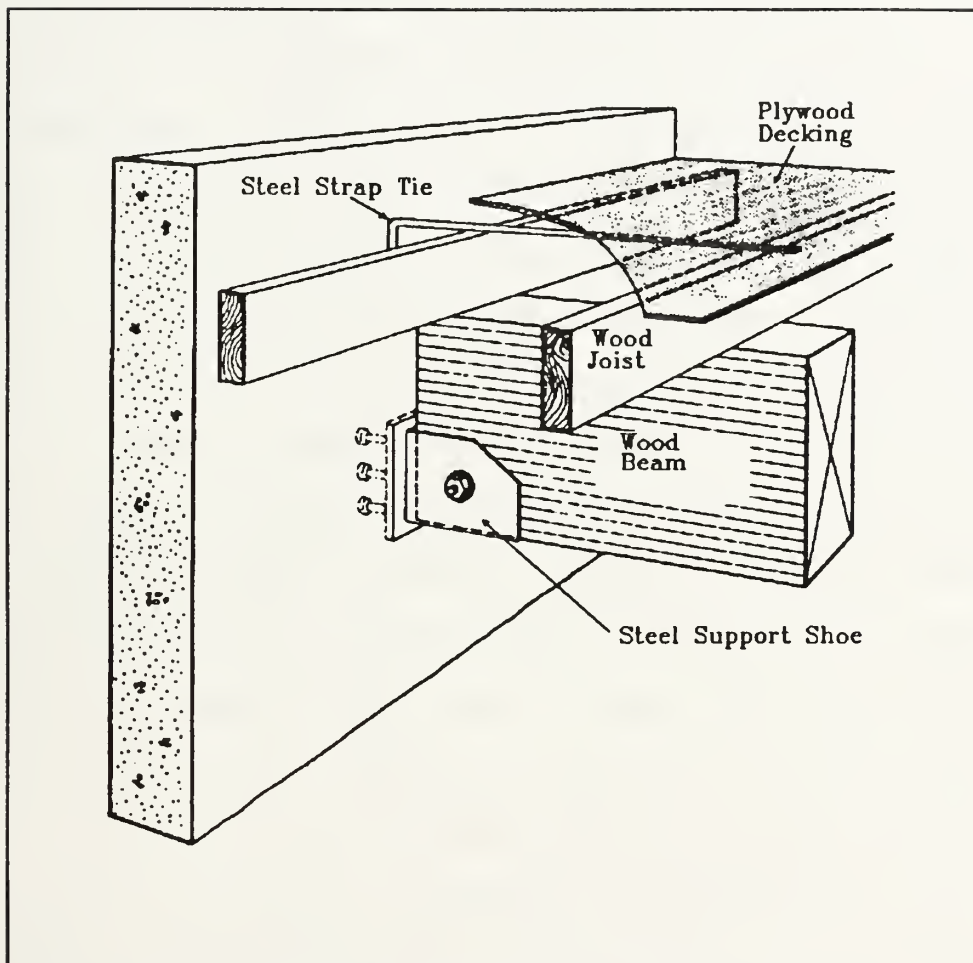

Figure 28: Wood Beam Supported in Steel Shoe

For buildings designed to sustain substantial floor loads, stronger connections are required than the connections previously discussed. For buildings that will have the heavy floor loads carried on steel beams, a connection as shown in figure 29 on the following page is required. In this connection, a full height pilaster can be used to support heavy beam loads. As an option, a smaller concrete corbel or a welded steel angle seat can be used where loading allows. In figure 29, note the importance of using ties to keep the edge of the pilaster from failing due to shear. Figure 30 on the following page shows a connection similar the wood ledger system of figure 27 except the connection in figure 30 uses a concrete ledger to support a precast double tee concrete beam. When a concrete ledger is used to support a concrete beam, the beam should rest on a neoprene pad as shown to allow for some rotational movement of the beam. Also, the beam should be tied in at the top. The main disadvantage of the systems shown in figures 29 and 30 is they both have protrusions which make forming and casting the panels much more difficult. For figure 30, the embedded rebar used to tie in the top of the precast beam can get in the way during the placement of the beam, so extra care (and more time) is required when using this system.

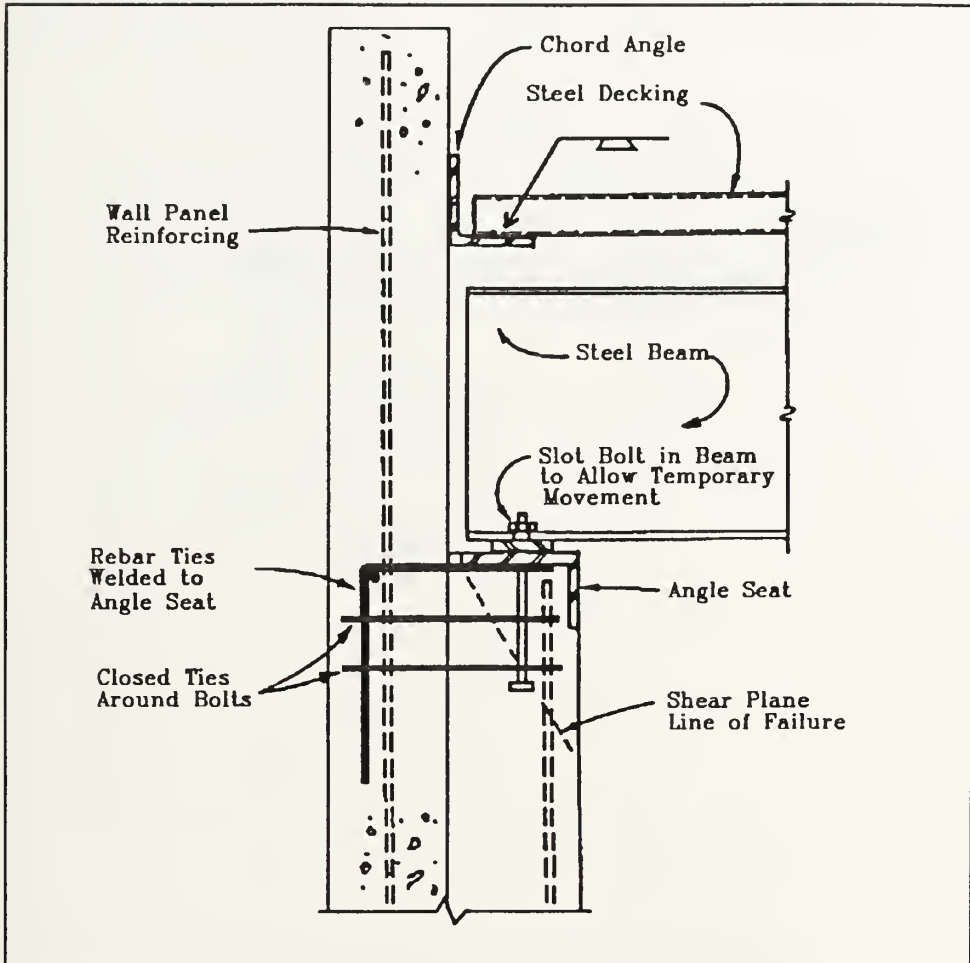

Figure 29: Steel Beam on Pillaster

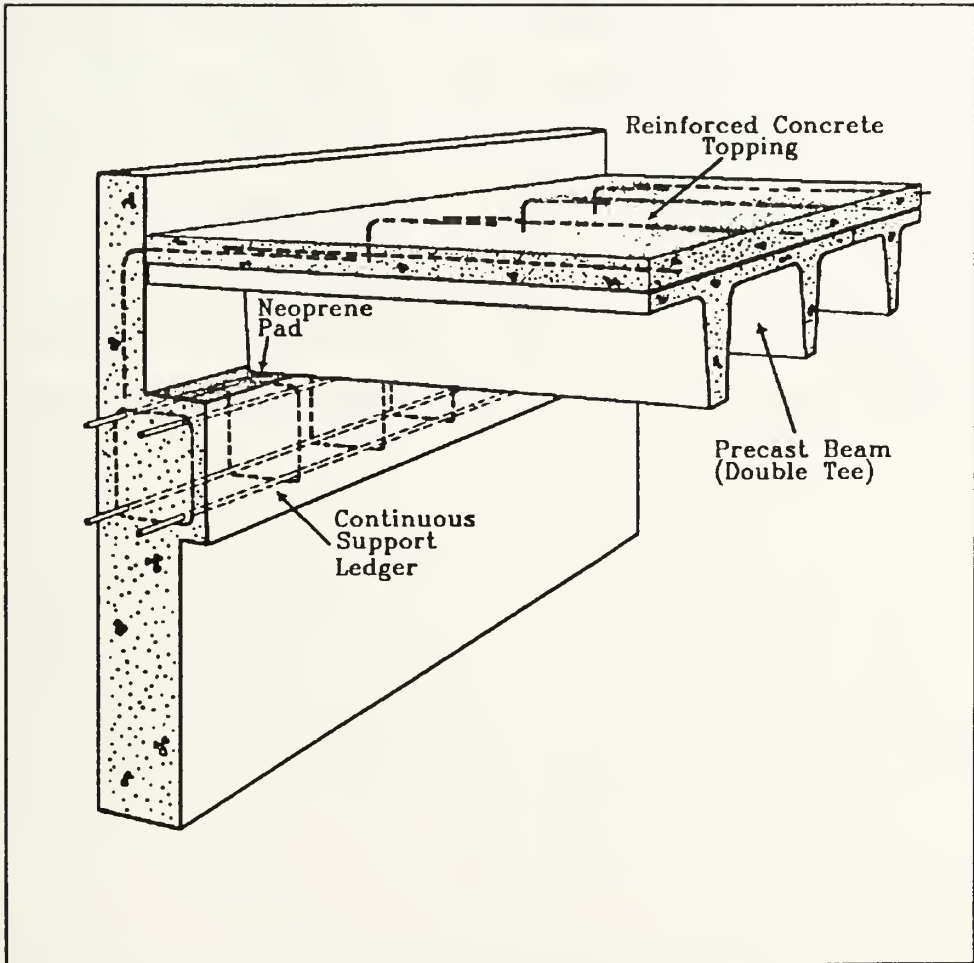

Figure 30: Double Tee on Concrete Ledger

CHAPTER EIGHT CONCLUSION

"With Adequate planning and proper procedures, tilt-up can be an efficient, safe method of erecting structural concrete walls quickly with a minimum of labor and formwork" (3:27). The key to tilt-up's economy is to effectively coordinate the work to avoid delays by maximizing the use of crane time to speed up the job. Tilt-up construction's natural economy, versatility, and availability of advanced architectural treatments give tilt-up the potential to grow and command a larger share of the total building construction market.

REFERENCES

1. Portland Cement Association, Tilt-up Concrete Buildings, Skokie, IL, 1989.
2. Dayton Superior Corporation, Tilt-up Construction Handbook, Miamisburg, OH, 1990.
3. American Concrete Institute, Tilt-up Construction, ACI Compilation No. 7, Detroit, MI, 1986.
4. The Burke Company, Burke on Tilt-up, Buffalo, NY, 1988.
5. Portland Cement Association, Connections for Tilt-up Wall Construction, Skokie, IL, 1987.

BIBLIOGRAPHY

American Concrete Institute, Tilt-up Construction, ACI Compilation No. 7, Detroit, MI, 1986.

Dayton Superior Corporation, Tilt-up Construction Handbook, Miamisburg, OH, 1990.

Hurd, M.K., "The Many Faces of Tilt-up, From Plain Surfaces to Works of Art", Concrete Construction, September, 1987.

Hurd, M.K., "The Tilt-up Opportunity", Concrete Construction, September 1987.

Portland Cement Association, Connections for Tilt-up Wall Construction, Skokie, IL, 1987.

Portland Cement Association, Tilt-up Concrete Buildings, Skokie, IL, 1989.

Portland Cement Association, Tilt-up Load Bearing Walls, Skokie, IL, 1979.

Richmond Screw Anchor Company, Products for Tilt-up Concrete Construction, Fort Worth, TX, 1980.

Schierloh, David, M., "Tilt-up: A Feat of Engineering", Tilt-up, Fall, 1991, pp. 6-7.

The Burke Company, Burke on Tilt-up, Buffalo, NY, 1988.

Thesis
C87473 Crompton
c.1 Tilt-up construction.

Thesis
C87473 Crompton
c.1 Tilt-up construction.

DUDLEY KNOX LIBRARY



3 2768 00016403 2