

ELECTRONIC WARFARE TECHNOLOGY

Raul Pereira Bittencourt

DUDLEY KNOX LIBRARY  
NAVAL POSTGRADUATE SCHOOL  
MONTEREY, CALIFORNIA 93940

# NAVAL POSTGRADUATE SCHOOL

Monterey, California



## THESIS

ELECTRONIC WARFARE TECHNOLOGY

by

Raul Pereira Bittencourt

Thesis Advisor:

Donald A. Stentz

Approved for public release; distribution unlimited.

June 1976

T174025



REPORT DOCUMENTATION PAGE		READ INSTRUCTIONS BEFORE COMPLETING FORM
1. REPORT NUMBER	2. GOVT ACCESSION NO.	3. RECIPIENT'S CATALOG NUMBER
4. TITLE (and Subtitle) Electronic Warfare Technology		5. TYPE OF REPORT & PERIOD COVERED Electrical Engineer; June 1976
7. AUTHOR(s) Raul Pereira Bittencourt		6. PERFORMING ORG. REPORT NUMBER
9. PERFORMING ORGANIZATION NAME AND ADDRESS Naval Postgraduate School Monterey, California 93940		8. CONTRACT OR GRANT NUMBER(s)
11. CONTROLLING OFFICE NAME AND ADDRESS Naval Postgraduate School Monterey, California 93940		10. PROGRAM ELEMENT, PROJECT, TASK AREA & WORK UNIT NUMBERS
14. MONITORING AGENCY NAME & ADDRESS (if different from Controlling Office) Naval Postgraduate School Monterey, California 93940		12. REPORT DATE June 1976
		13. NUMBER OF PAGES 143
		15. SECURITY CLASS. (of this report) Unclassified
		15a. DECLASSIFICATION/DOWNGRADING SCHEDULE
16. DISTRIBUTION STATEMENT (of this Report) Approved for public release; distribution unlimited.		
17. DISTRIBUTION STATEMENT (of the abstract entered in Block 20, if different from Report)		
18. SUPPLEMENTARY NOTES		
19. KEY WORDS (Continue on reverse side if necessary and identify by block number) Electronic Warfare, Electronic Countermeasures		
20. ABSTRACT (Continue on reverse side if necessary and identify by block number) An analysis of the modern technology employed in Electronic Warfare systems is carried out. Electronic and optical techniques presently used in the detection, localization, processing and identification of signals, linked with active and passive countermeasures and countercountermeasures are analyzed. "Real-world" designs and configurations are discussed with respect to effectiveness, reliability and design and operational trade-offs. Topics are divided according the modern classification of Electronic Warfare cover-		



ing confusion reflectors, masking and deceiver jammers, intercept receivers as well as the new field of Electro-Optical Electronic Warfare. Special characteristics inherent to the surface Navy are pointed out. In the Appendices, the experiment of a circuit devised to be useful in signal recognition is described, and a list of missiles with electronic and guidance characteristics is presented.





ELECTRONIC WARFARE TECHNOLOGY

by

Raul Pereira Bittencourt  
Lieutenant Commander, Brazilian Navy  
M.S.E.E., Naval Postgraduate School, 1975

Submitted in partial fulfillment of the  
requirements for the degree of

ELECTRICAL ENGINEER

from the  
NAVAL POSTGRADUATE SCHOOL  
June 1976



## ABSTRACT

An analysis of the modern technology employed in Electronic Warfare systems is carried out. Electronic and optical techniques presently used in the detection, localization, processing and identification of signals, linked with active and passive countermeasures and countercountermeasures, are analyzed. "Real-world" designs and configurations are discussed with respect to effectiveness, reliability and design and operational trade-offs. Topics are divided according to the modern classification of Electronic Warfare, covering confusion reflectors, masking and deceiver jammers, intercept receivers as well as the new field of Electro-Optical Electronic Warfare. Special characteristics inherent to the Surface Navy are pointed out. In the Appendices, the experiment of a circuit devised to be useful in signal recognition is described, and a list of missiles with electronic and guidance characteristics is presented.



## TABLE OF CONTENTS

TABLE OF ABEREVIATIONS.....	8
ACKNOWLEDGMENT.....	10
I.    INTRCDUCTION.....	11
A.    TEE IMPORTANCE OF ELECTRONIC WARFARE.....	11
B.    CLASSIFICATION AND BASIC DEFINITICNS.....	14
C.    CVERVIEW.....	17
II.   CONFUSION REFLECTORS.....	19
A.    TYPES AND APPLICATIONS.....	19
1.    Chaff.....	19
a.    Payload Design.....	20
b.    Cartridge Launchers.....	22
(1)    Dispenser Sets.....	23
(2)    Rockets Launched from Aircraft..	25
(3)    Rockets Fired from Vessels.....	25
c.    Modern Systems.....	26
2.    Rope.....	27
3.    Corner Reflectors.....	28
B.    CCUNTERCOUNTERMEASURES.....	28
III.  REFEATERS, TRANSPONDERS AND DRONES.....	31
A.    REFEATERS AND TRANSPONDERS.....	31
1.    False Target Generators.....	32
a.    Straight-Through Repeaters.....	33
b.    Gated Repeaters.....	34
c.    Single-Frequency Transponders.....	35
d.    Search-Lock-Jam-Transponders.....	35
2.    Track Breakers.....	37
a.    Inverse Gain Modulation.....	37
b.    Range-Gate-Pull-Off (RGPO).....	38
B.    IFCNES.....	43
C.    CCUNTERCOUNTERMEASURES.....	44



	1. False Target Generators.....	44
	2. Track Breakers.....	45
IV.	MASKING JAMMERS.....	47
	A. TRANSMIT TUBES.....	49
	B. HIGH POWER JAMMERS.....	53
	C. COUNTERCOUNTERMEASURES.....	54
V.	INTERCEPT RECEIVERS.....	58
	A. UTILIZATION IN ELECTRONIC RECONNAISSANCE.....	58
	B. BASIC CONFIGURATIONS.....	60
	1. Crystal Video Receivers (CVR).....	61
	2. Instantaneous Frequency Measuring (IFM) ..	62
	3. Superheterodyne Scanning Receivers.....	64
	4. Compressive Receivers.....	71
	5. Channelized Receiving Systems.....	72
	C. SIGNAL PROCESSING.....	74
	1. Computers in Electronic Warfare.....	74
	a. RHAW Mini-Computers.....	76
	2. Acousto-Optical Signal Analyzer.....	78
	D. MODERN SYSTEMS.....	80
	1. RHAW.....	80
	2. ESM - ELINT.....	83
	E. DIRECTION FINDERS.....	86
VI.	THE MISSILE THREAT.....	90
	A. MISSILE WEAPONS.....	90
	1. Surface-to-Air Missile Weapons (SAM).....	90
	2. Surface-to-Surface Missile Weapons (SSM) ..	93
	3. Air-to-Surface Missile Weapons (ASM).....	94
	4. Air-to-Air Missile Weapons (AAM).....	95
VII.	ELECTRO-OPTICAL ELECTRONIC WARFARE.....	97
	A. GENERAL.....	97
	B. CLASSIFICATION.....	98
	1. Infrared Warning Receivers.....	99
	2. Imagery Systems.....	101
	3. Denial-Jamming Lasers.....	102
	4. Deception-Jamming Lasers.....	104
VIII.	SHIPCARD ELECTRONIC WARFARE SYSTEMS.....	107





Appendix A: FRF AND PULSE WIDTH MEASURING CIRCUIT.....	116
Appendix E: MCDEFN MISSILES.....	129
LIST OF FIGURES.....	137
LIST OF REFERENCES.....	138
INITIAL DISTRIBUTION LIST.....	142



## TABLE OF ABBREVIATIONS

AAM	air-to-air missile
ASM	air-to-surface missile
CFA	cross-field amplifier
CFAR	constant false alarm rate
CCMINT	communications intelligence
CVR	crystal video receiver
DF	direction finder
DINA	direct noise amplification
DOA	direction of arrival
DPEWS	design-to-price electronic warfare system
ECCM	electronic countercountermeasures
ECM	electronic countermeasures
ELINT	electronic intelligence
EOEW	electro-optical electronic warfare
ER	electronic reconnaissance
ESM	electronic support measures
EW	electronic warfare
FLIR	forward looking infrared
IAGC	instantaneous automatic gain control
ICBM	intercontinental ballistic missile



IFM            instantaneous frequency measuring (receiver)  
 IFT            instantaneous Fourier transform (receiver)  
 IR             infrared  
 IECM          infrared countermeasures  
 IRLR          infrared laser ranger  
 LABAWS       laser homing and warning system  
 LAMFS        light airborne multi-purpose system  
 LLITV        low light level television  
 MTEF         mean time between failures  
 MTI           moving target indication  
 QRC           quick reaction capability  
 BECC         rapid bloom offboard countermeasures  
 RHAW         radar homing and warning  
 SAM          surface-to-air missile  
 SIGINT       signal intelligence  
 SSM          surface-to-surface missile  
 TOA          time of arrival  
 TRF          tuned radio frequency (receiver)  
 TWS          track-while-scan (radar)  
 TWT          traveling wave tube



## ACKNOWLEDGMENT

The author is sincerely grateful to his thesis advisor, Professor Donald A. Stentz, for his professional guidance, dedicated counsel and continual support during the preparation of this thesis.





## I. INTRODUCTION

### A. THE IMPORTANCE OF ELECTRONIC WARFARE

A common form of criticism of military planners of all time has been to say that they are preparing to fight the previous war, never the current one. After World War II this criticism seemed to lose meaning because during the two decades following everybody was preparing for an exclusive nuclear conflict. Ironically, conditions changed and then the planners discovered that they should switch and become prepared for a vastly improved conventional threat. Indeed, NATO's new view of the Warsaw Pact's threat is now one which has evolved into low-level strike by manned bombers combined with a high electronic warfare capability [1].

Traditionally the Russians have attached great importance to the concepts of Electronic Warfare. This can be observed by looking at the extensive bibliography of their texts on the subject. In order to illustrate this point the following quotation has been taken from a 1968 Russian text transcribed into English [2]:

"...Success in radio war is achieved by superiority over the enemy in the quantity and quality of radio electronic technology and skill of its combat application. Thus, in the contemporary stage of development of methods of armed combat, electronic means have become weapons in the literal meaning of the word - weapon of radio war."



Electronic Warfare (EW) is becoming an ever increasing factor in the military equation especially after the large deployment of electronically guided missiles in all kinds of small ships giving them tremendous firepower. The functions of electronic detection, localization and tracking of unidentifiable or enemy emissions, as well as passive and active jamming, become therefore vital to counteract the missile threat.

The field of EW is also expanding. Restricted to the use of chaff and single noise jammers in World War II, modern EW is concerned with everything from portable transceivers to satellite operations in space. Besides this, EW is also spreading its scope to the visual and infrared regions of the spectrum due to the advent of the laser and sensitive optical sensors.

During the October 1973 Yom Kippur War several new equipments and techniques found extensive application by both sides being used on land, at sea and in the air. Lessons learned from this conflict have been pointed out by numerous war experts and official sources, with detailed analysis appearing in the literature.

As a possible result of these lessons and also from the experience in Asia, EW expenditures have increased substantially in recent years all around the world. This has provided the necessary means for an expansion of research, development, testing and evaluation (RDT & E) of new technologies.

Another point of great importance is the apparent downgrading of security classification given to EW. The United States Department of Defense's new initiatives on sharing its front line EW technology with its NATO partners and other friendly nations have opened a significant



international market for EW equipment. This fact also has been reported as a recognition that most of the military aircraft now offered on the export market cannot be effective without their full complement of EW capabilities. As a consequence, the commercial sales of EW equipment have increased more than 500% during 1975.

However, despite everything that has been said before, EW still has its critics, it is often underemployed, and its understanding has suffered from high security classification. The principal sources of criticism are that EW is too expensive, hard to test and does not "kill". The accusation of high cost is primarily caused by the constant changes and updates required by the EW systems. Indeed, to keep the advantage over the enemy, one side must not only be permanently researching and developing new techniques and equipments but also there must be continuous intelligence effort to determine what is happening on the other side. This is evident in today's rush for capability in the 18-40 Ghz spectrum band and also in the new field of Electro-Optical Electronic Warfare.

This mutant state of technology is one of the characteristics of EW. It is like a vicious circle. As for example, the development of a new radar technique will require a suitable countermeasure, which in turn will cause the development of a new countercountermeasure, and eventually force a new radar technique to be devised. There is of course a lag between each stage of the process that can range from days to years.

As pointed out by the critics, this circularity is highly expensive since all radiating electronics can be jammed if one can afford to pay the price for it. A goal of countercountermeasures is to make this cost prohibitive, thereby breaking the cycle.



Against the accusation of high cost, EW advocates reply that Weapon Systems are not cheaper and also the complexity and need for constant modernization of EW is nothing more than a proof of its importance. The one who possesses the better technology certainly wins a very important point in the battle.

The second accusation is that EW is hard to test, that is, to have its effects evaluated. The defense says that this is not a cause but its effect. The cause is that EW is probably underused in the services of several nations, especially in the Surface Navy [3]. It is certainly not an easy task to simulate an environment similar to the one that can be found in a spectrum saturated with unexpected signals. However, constant training and proper technical knowledge, allied to the existence of complete training systems, make the job at least possible. Besides this, EW has been tested on the battlefield and valuable lessons have been learned from these past experiences.

Finally, the third accusation is that EW does not "kill". Those in defense of EW counter that weapons do not "jam"... Neutral observers do not see here any big problem and indicate that it is just a matter of properly using the two options: one can jam and/or kill. It is probably true that some years ago a military officer felt more confident if he knew that under his control there were powerful missiles instead of EW equipment. However, a considerable improvement in the reliability of these equipments, a better understanding of the theory and operation of these devices and past experience in previous conflicts now allow for the necessary confidence in the EW concept.

## E. CLASSIFICATION AND BASIC DEFINITIONS





Electronic Warfare is commonly defined as military action involving the use of electromagnetic energy designed to allow friendly forces to use their electronic or optical equipment effectively but, at the same time, reduce or deny hostile use of the electromagnetic spectrum by the enemy. The more adopted divisions of EW are:

- Electronic Support Measures (ESM)
- Electronic Countermeasures (ECM)
- Electronic Countercountermeasures (ECCM)

A possible fourth division is Signal Intelligence (SIGINT) more frequently however considered as part of ESM.

\* Electronic Support Measures is intended to obtain information which can be useful in an electromagnetic conflict. This information can be used only to provide detection and threat warning or in addition can be used to conduct ECM or ECCM. Therefore, ESM normally involve actions taken to search for, intercept, locate and analyze radiated electromagnetic energy. In a broader sense these support measures also include all kinds of reconnaissance missions, including industrial espionage.

\* Electronic Countermeasures is that division of EW involving actions taken to prevent or reduce an enemy's effective use of the electromagnetic spectrum. It is possible that these actions be carried out as a brute-force approach or they can try to deceive or confuse the enemy. Sometimes it is also helpful to classify ECM as actives or passives.

\* Electronic Countercountermeasures is that division of EW involving actions taken to oppose the ECM of the enemy and thus insure an effective use of the electromagnetic spectrum by friendly forces.



Electronic Warfare deals with all types of systems: radar, sonar, communications, weapons guidance, navigation. The available literature, however, is more concerned with the radar threat. Although the basic principles are common to all systems, it is also true that each one has its own particularities.

Regarding the communications aspect, for instance, as compared with the radar case, some characteristics should be pointed out:

\* the transmitter and the receiver are at different locations. Thus, there is only a one-way path of transmission involved and consequently jammers and communications transmitters compete in equality of conditions, both with an inverse square of distance dependence factor. In the radar case the two-way path is responsible for an inverse fourth power of distance dependence factor in the Radar Equation that is a severe disadvantage at normal operating ranges.

\* presently, communication systems are of much more varied types. Indeed several different schemes of modulation are not only possible but widely used. In the radar case, a great percentage of the systems actually in use are of the conventional pulsed mode. Also, communications links could be expected to exist in almost any location of the spectrum ranging from low frequencies to the infrared or optical regions.

\* communications links are more flexible regarding time of emission, that is, the transmission is more under control of the operator and less dependent on extraneous factors.

These characteristics make communications EW more difficult and less predictable than radar EW and thus its results are not easily analyzed.



## C. OVERVIEW

Chapter II will cover Confusion Reflectors, especially chaff which, due to its effectiveness, relative simplicity, wide application and stable use, seems to deserve a broad coverage.

Chapter III deals with active deceiving countermeasures. These are more sophisticated devices and normally their application has in mind specific equipments. Thus, there is a great variety of techniques and the more important concepts are presented.

Chapter IV is concerned with Masking Jammers and here, unlike deception jamming, the techniques have a characteristic of universality. Therefore attention is more concentrated in the components of the system, especially the power amplifiers.

The three chapters discussed above belong to the ECM division. Related ECCM are covered at the end of the respective chapter instead of putting them all together in a separate chapter.

Chapter V is dedicated to ESM. Being a vast field, efforts are concentrated in the basic principles of the Intercept Receiver. Importance is given to some forms of signal processing which is generally complex and an important part of the system.

Chapters VI and VII have in mind the Electro-Optical aspect of EW as related to the missile threat. Although this is not a true division of EW, the importance and infancy of



the field led to the idea of concentrating basic topics in a separate chapter.

Chapter VIII presents some particular aspects concerning shipborne EW. The fundamental ideas are contained in the preceding chapters however for reasons discussed in that chapter it appeared worthwhile to emphasize more carefully some characteristics of the Surface Navy.

Appendix A considers the development of a circuit which could be useful in analyzing the characteristics of an unknown emission. The parameters of interest are the pulse repetition frequency (PRF) and pulse width (PW) of a conventional pulsed radar. The topic is related with chapter V where a more global analysis is carried out.

Appendix B lists several missiles according their primary functions. The description of each type is restricted to the data found in the open literature, concerning the aspects of more importance to EW such as methods of guidance, flight profile, carrying platforms, range and speed.





## II. CONFUSION REFLECTORS

### A. TYPES AND APPLICATIONS

Confusion reflectors are devices that are used to produce echoes other than those of the proper targets and so divert attention of the radar. The use of these devices is commonly divided into:

- \* confusion of surveillance systems
- \* screening against radars.

The basic idea is then to make true target echo detection and recognition difficult by immersing desired targets in a field of many equivalent false targets or hiding them in a compact cloud of echoes.

Three confusion reflectors that are normally used to obtain large radar cross sections from small size targets are:

- \* resonant dipoles - chaff
- \* non resonant streamers - rope
- \* corners or other reflective geometries - angels.

#### 1. Chaff

Chaff consists of a large number of dipole reflectors whose length is approximately one-half wavelength of the frequency of the radar to be countered. Thus one can



use chaff of several different lengths in the same package to be effective against radars of widely different frequencies. Chaff is also polarization sensitive but in certain types the dipoles are projected to fall at an angle to the horizontal, making them effective for all types of polarization. Chaff was used during World War II for the first time in July 1943 by the RAF [4]. It was so effective that German radar operators are reported to have exclaimed:

'Himmel, the planes are doubling themselves!'

More recently, chaff was again very effective during the Linebacker 2 raids on North Vietnam when USAF Boeing F-52s equipped with noise jammers and chaff were employed.

Still more impressive seems to have been the use of chaff in the October 1973 conflict between Israeli and Arab forces. According to the press, for each Russian Styx missile launched the Israelis fired in response long range chaff rockets and also screening clouds of chaff were released by packages from short range mortars. No single hit was obtained in the firing of more than 50 Styx. This is to be compared with the fact that six years earlier, when neither of these countermeasures were employed, of six Styx missiles fired by the Arabs, four sent the Israeli destroyer Eilat to the bottom and the other two sank a merchantman.

It is interesting to notice that chaff can also have some peaceful applications. Examples are to produce distress signals, position markers and as an inexpensive means of assessing calculations of air current direction and speed at high altitudes. Also, when dropped into thunderstorms, to reduce the probability of lightning striking the ground.

#### a. Payload Design



There are several considerations that must be taken into account in its design. In principle, to maximize reflection efficiency, the strips are made as narrow as possible provided the electrical resistance is not greatly increased. However other factors such as air resistance, drag, bandwidth of the response and mechanical strength also affect the choice of the optimal width. Indeed chaff must satisfy the following conditions in order to be effective:

- \* high radar cross section
- \* correct response to desired frequencies and polarization
- \* resistance to corrosion and high temperatures
- \* compactness yet good dispersal characteristics
- \* rapid bloom and specific fall rate
- \* low cost
- \* ability to withstand high acceleration and the shock of ejection.

Chaff can be made of several different materials each one with trade-offs and so more suitable for a specific application:

• Aluminum Foil, the oldest but still popular form of chaff because it is an economic material. In order to give more uniformity to the cloud, aluminum foil chaff is usually bent in one extreme. It is employed when the dispensing condition is not severe.

• Silver Metallised Nylon, used under more severe dispensing conditions like violent turbulence. It consists of a nylon monofilament coated with silver. Fall rates are about 0.6 m/s.

• Aluminized Glass Fiber, more useful at higher frequency ranges due to its very small diameter. Being less dense the fall rate is slow and large chaff clouds remain suspended for a long time. Sometimes the coating is also



done with zinc.

The cartridges that enclose chaff are of several formats such as rectangular, cylindrical or the square cross section type.

The rectangular type normally has standard dimensions of 3 in x 5 in with thickness variable between 3/8 in and 2 in. It is normally housed in magazines. A representative model of this package is the RR-72.

An example of the cylindrical format is the RR-136 and RR-137 series developed to meet an urgent operational need during the Southeast Asian conflict. The payload has two versions, aluminum foil and aluminum coated glass fiber. It can be cut to one radar band or can provide multiple band coverage.

The more modern type is the square cross section because this configuration makes maximum utilization of available payload volume and provides a faster blooming effect when dispensed. As an example there exists the RR-170A/AL made with aluminum coated glass and the RR-170B/AL with aluminum foil, both developed by Tracor Inc., USA. Dimensions are about one inch square cross section and length 8.25 in. An electrically activated pyrotechnic squib inserted in the base of the cartridge ejects the payload from the dispenser. The cartridge contains five multi-band dipole cuts to provide protection against all existing radar controlled threat systems.

#### b. Cartridge Launchers

There are basically three ways of launching chaff:





- \* dispenser sets
- \* rockets launched from aircraft
- \* rockets fired from surface vessels.

### (1) Dispenser Sets

Depending on their location on the aircraft, dispenser sets are of several types:

- integrated type, housed within the airframe or fitted on the structure. This configuration has the advantage of not altering the aerodynamics of the aircraft and is normally preferable although sometimes there is no more internal space available. The installation however is often difficult and expensive. Almost any suitable opening is useful because the dispensers can eject the cartridges in any direction, up, down, sideways.

- conformal or scab-on type, added to the aircraft structure or to existing pylons. The installation is easy but this new appendage to the pylon can change its design aerodynamics.

- external or pod mounted, in which case depending on the carrying aircraft the pod must possess supersonic characteristics. The inherent flexibility of this arrangement permits several pods to be installed on one aircraft greatly increasing the amount of chaff available.

The composition of the dispensing set depends in part on the intended tactical use of chaff. The more common patterns are bursts and corridors, the former used as deception to simulate false targets and the latter as an effective means of denying detection by hiding the target from a search radar. Fuze detonation is still another use of chaff. Even if the missile guidance radar realizes that the chaff cloud represents a false target, the missile will explode if it passes close enough to cause a



sufficient doppler shift. Another way of viewing these tactical uses is by considering self-defense or screening actions.

A typical dispensing system for self-protection normally consists of a control unit, a programmer, a sequencer and the housing and dispensing block.

- the control unit is mounted in the cockpit and provides means for the pilot to control the system. Normally its functions allow selection of the dispenser that will make the launch and a choice of manual or automatic ejection. In manual the pilot controls the individual launching by pressing a key. In automatic, the pattern of ejection has been previously stipulated in the programmer. The control unit also provides visual indication of the actual remaining payload.

- the programmer unit can be installed in any convenient location in the aircraft. It pre-establishes the number of expendables to be ejected and the interval between them. The normal pattern consists of "salvos" each one with certain number of bursts. The output of the programmer box are pulses that are sent to the sequencer unit - one for each dispenser - selected by the control unit.

- The sequencer unit receives the pulses from the programmer which will be used to ignite the propellant in the impulse cartridge. Another type of ejection could be pneumatic, that is by pulses of compressed air.

- The housing unit greatly varies with the model of the dispenser and the format, number and type of cartridges.

At this point it must be noticed that almost all types of cartridge launchers for self-defense use not chaff alone but the expendables are a mixture of chaff, infrared flares and miniature transmitters jammers. The control unit and programmer give the pilot a choice of the



type of expendables he will use as self-defense. In more modern systems activation of the ejection can be made automatically by means of a threat sensing system, like a missile launch detector.

For screening protection, another type of dispenser is now being used, the chaff cutter dispenser. The concept of cutting chaff from a continuous supply to various dipole lengths, while in flight, has numerous advantages. It is a high capacity system capable of storing a large quantity of chaff of metalized glass fibers on a reel. The bulk fibers are fed from the reel to a cutter mechanism and then dispensed through ducting into the airstream about the aircraft.

## (2) Rockets Launched from Aircraft

The rocket is fired forward of the aircraft and after a variable delay the ejection begins providing a continuous corridor of chaff, whose length and density are adjustable by an escapement mechanism. When fired individually it can give self-protection for the aircraft for several seconds. By firing multiple rockets area saturation can be obtained to provide protection for accompanying aircraft.

Forward-fired chaff rockets can be used to break lock of airborne interceptor radars. Such a radar operating in a leading edge range-track mode can reject aft-deployed chaff.

## (3) Rockets Fired from Vessels

The advantage of course is to make the screening of the vessels self-sufficient. To accomplish this a program called Chaffroc was carried out a few years



ago but canceled in 1974. The system was scheduled to be installed in the nuclear-powered guided missile cruisers class "Virginia" and several other smaller ships.

Presently, a system intended to substitute the Chaffroc program is in production for both United States and foreign governments: RBOC (Rapid Bloom Offboard Countermeasures), developed and manufactured by Hycor Inc., USA.

RBOC is a family of mortar launchers and countermeasure cartridges suitable for protecting ships of all sizes against forces employing active radar or passive infrared seekers. The number of launchers and the number of tubes per launcher can be tailored to the needs of each particular ship. The payload could be chaff and/or an infrared flare equipped with parachute and flotation device.

#### c. Modern Systems

\* AN/AIE-40, manufactured by Tracor, Inc., USA, is a lightweight, aerodynamically configured dispenser system designed to provide self-protection for high performance aircraft against radar controlled or IR homing weapons threats. It was developed for the F-4 aircraft with possible modifications for several other tactical aircraft and helicopters. It comprises four dispensers, each one with 30 decoys - chaff, flare or both - mounted on the inboard and outboard sides of armament pylons. The system uses the RR-170A/AL or RR-170B/AL chaff decoy cartridges.

\* LC-5000, a cartridge launcher system produced by the French company Alkan Equipements Aeronautiques. It is a conformal type launcher using cylindrical cartridges disposed in cartridge blocks. A block can contain 16 chaff cartridges or 9 flares. The number of blocks varies from two





up to six, in order to match different sizes of aircraft.

\* AN/ALE-29A, a dispenser used by the US Navy and manufactured by Lundy Electronics Systems, USA, Goodyear Aerospace Corporation, USA and also Tracor. It is capable of dispensing chaff, flare or other expendables. An adaptation is available to permit the use of mixing load with selective dispensing of either type of decoy. It could be mounted within the airframe or in pods. The payload is ejected by an electrically initiated impulse cartridge that is used to generate gas pressure, expelling the payload from the sleeve.

\* AN/ALE-39 is a system produced by Goodyear and scheduled for retrofit into A-4, A-6, A-7 and F-4 aircraft as well as to be installed in new US Navy tactical aircraft including the F-14. It is also suitable for adaptation to helicopters. The ALE-39 uses several units similar to the ones used on its predecessor ALE-29. Others were changed in order to provide more programming flexibility, payload loading versatility and a new operating mode initiated by the aircraft warning receiver system. The capability of the system is a load of up to 60 chaff, flare and jammer payloads loaded in any combination of multiples of 10. More than five hundred of these systems were delivered last year.

Tasker Industries, USA, is working on an A-band noise jammer capable of being ejected by this dispenser as well as by the ALE-29. Typically, the output for these transmitters is about 10 watts and they can radiate for about five minutes, the suspension being done by small parachutes. After ejection from the dispenser, a battery is activated automatically, the antenna deploys and radiates omnidirectionally.

## 2. Ecpe



For use against low-frequency radars, chaff must be very long and so large strips of aluminum - rope - are used. Rope has a secondary and catastrophic effect on high voltage transmissions lines and its use for training over continental land is very dangerous. In addition to this disadvantage, due to the difficulty in storing and launching, it is not commonly used.

### 3. Corner Reflectors

Corner reflectors are more suitable in land applications where by careful disposition they can simulate bridges, factories, etc... and so confuse the navigation of the enemy. They can also be used in airborne situations when a small airframe like a drone must be made to look like a big bomber.

It must be pointed out that in many cases the desired effect is to make a large bomber look like a small airframe. In these cases the formation of corners in the structure must be avoided by careful design. It has been reported for instance that the new bomber B-1 has a radar cross section of only 1/25 of the B-52, although not much smaller.

### B. COUNTERCOUNTERMEASURES

The definition of clutter is a conglomeration of unwanted radar echoes. So, chaff is a type of clutter and conventional anti-clutter techniques can be used to reduce its jamming effects.



The best method of countering clutter, and thus chaff, is by using a Moving Target Indication (MTI) radar which, as is recalled, uses the doppler shift in frequency caused by moving targets to distinguish these from fixed or slow moving targets. Chaff, normally being a relatively slow target, is then differentiated from the fast moving aircraft. Chaff velocity is a function of the characteristics of its construction and packing, of the method of launching and also of wind conditions. It must be noticed that when chaff is employed as an ICBM penetration aid its velocity is comparable to the missile itself due to the rarified atmosphere.

Other anti-clutter techniques commonly employed in pulsed radars are:

- amplifier with a logarithmic characteristic
- CFAR (constant false-alarm rate)
- rejection filters
- IAGC (instantaneous automatic gain control)
- frequency and/or polarization discrimination.

The first one is based on the fact that some types of clutter are described by a Rayleigh characteristic. It can be shown that if any Rayleigh distribution is applied to the input of a receiver with an idealized logarithmic input-output law, the resulting r.m.s. fluctuation about the mean at the receiver output is a constant, independent of the input fluctuations and proportional to the slope of the logarithmic law. The mean value can be removed by passing the output of the logarithmic channel through a differentiator and then the fluctuation components of clutter are left at a constant level, independent of range and intensity and thus easier to get rid of [5].

The technique described above is one possible configuration of the CFAR concept. The idea of CFAR is



based on the fact that either an operator or a digital processor would like the false-alarm rate reasonably constant in the presence of variable levels of noise, having the radar automatically adjust its sensitivity as the intensity of interference varies [6].

IAGC corresponds to radio AGC (Automatic Gain Control) however is faster acting. Echo pulses pass with little attenuation but longer pulses such as those from extended clutter targets are attenuated. IAGC is no longer used in modern search radars.

Clutter-rejection filters are based on the matched-filter principle and here the basic idea is to increase the target-to-clutter signal ratio.

Finally, remembering that chaff is both frequency and polarization sensitive, different modes of operation will result in diminished cross sections of the chaff dipoles and this will minimize its jamming effectiveness.





### III. REPEATERS, TRANSPONDERS AND DRONES

#### A. REPEATERS AND TRANSPONDERS

A large number of countermeasures techniques are based on the radiation of deceptive signals simulating radar target echoes [7]. These techniques have several advantages over the "brute-force" method of jamming:

- low average power output requirements
- less susceptible to anti-radiation missiles due to intermittent signal
- signal spectrum can be concentrated at frequency of the victim
- no betrayal of the fact that countermeasures are being employed which means the enemy is accepting incorrect information and is being deceived. Indeed, if he knows he is being countermeasured, as in denial jamming, he can attempt to obtain the information he wants by other techniques, for example, by employing different frequency bands.

On the other side, a disadvantage of deceptive signals is the fact that this countermeasure must be "matched" to the victim equipment and so there is not the characteristic of "universality" that is present in denial jamming. As an example, a noise-modulated signal of adequate power will obscure a target to several radar types, while a pulsed reply of particular characteristics may be expected to constitute an effective countermeasure only against a specific class of radars. So, in deceptive jamming, unlike denial jamming, it is normally necessary to obtain a more



complete electronic intelligence from the enemy.

Deceiver systems are commonly classified into two general categories:

- false target generators
- track breakers.

The difference between these categories depends on the type of radars they are to operate against. Both categories may be realized by repeaters, with a "straight-through" feature, or transponders which normally depends upon some frequency memory or tuning procedure.

### 1. False Target Generators

In order to understand the difficulty involved in generating a false target it is possible to subdivide the search volume of the radar in four areas, as shown in the illustration below [8]:

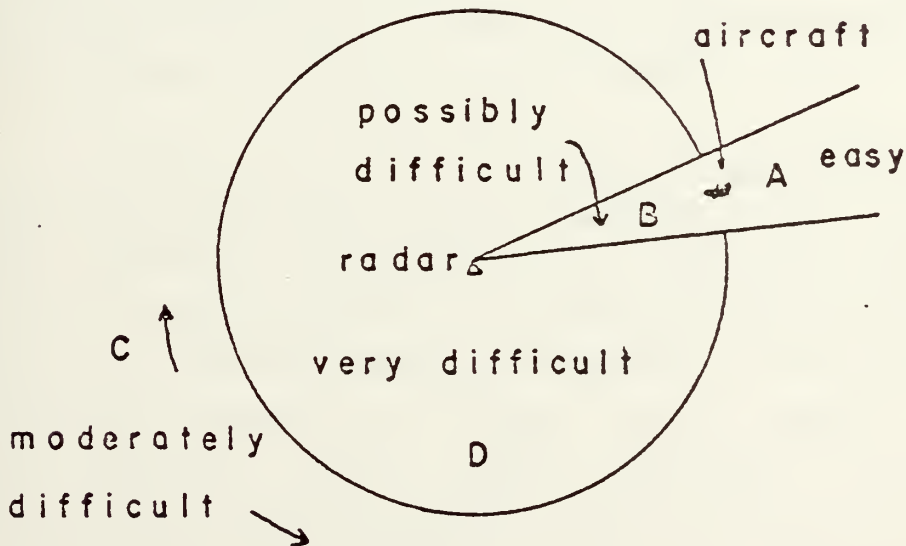

Figure 1 - FALSE-TARGET GENERATION



- area A has the same azimuth of the target and increased ranges. In this area it is relatively easy for the target to generate false echoes.

- area B has smaller ranges in the same azimuth region. The generation here is possibly difficult.

- area C has different azimuth region and increased ranges. The generation of false targets is moderately difficult.

- area D has different azimuth region and smaller ranges, in which case it is very difficult to create false echoes.

False target generators are typically employed against Track-While-Scan radars such as search radars with continuously rotating antennas.

#### a. Straight-Through Repeaters

For a repeater or transponder to effectively deceive an active system it must possess adequate gain and power output capability to provide a signal at the radar input at least of the same order of magnitude as that of the true echo signal received from the target.

The total required repeater gain is independent of radar power and range, being proportional to the square of the frequency of operation, the effective radar cross section to be simulated and the jamming-to-echo signal ratio required to produce the desired effect at the radar. With the deceptive repeater of constant gain, signal strength varies correctly with range, although it does not scintillate realistically unless provisions are made for this by means of a random modulation scheme. At short ranges the repeater may saturate, and gain is reduced.



Another factor of interest when dealing with jammers is the "burnthrough" range, that is the minimum distance that jamming can be effective. Burnthrough range depends on the power of the repeater, the target radar cross section and the minimum jamming-to-signal (J/S) ratio needed for deception. This ratio is a function of the radar type and method of deception being employed. When the repeater signal must enter the radar antenna sidelobes much higher J/S ratios are required. Several references in the literature deal with the derivation of formulas necessary to calculate all these quantities [9]. Sometimes the results are also presented in graphical format [10].

In its simplest configuration, the straight-through repeater is one in which the signal is received, amplified in a broadband amplifier and reradiated without frequency translation. The isolation between receiving and transmitting antennas must exceed the active gain at all frequencies so that the system will not oscillate due to coupling of energy back into the input.

#### k. Gated Repeaters

In applications where it is impractical to obtain sufficient isolation between antennas to prevent oscillation, or when it is desired to perform the receiving and transmitting function with a single antenna, it is necessary to introduce time gating. During the arrival of the pulses at the repeater there are instants of reception and of transmission. The signal returned to the radar, although being a series of pulses instead of just one, cannot be easily distinguished in the indicators, but it has a much wider spectrum and so can be discerned by detuning the receiver or with a signal analyzer.





In both repeaters false targets can be generated at the same azimuth sector but at increased ranges by varying the delay in the channel. Also a multiplicity of false echoes can be obtained at constant range but over a large azimuth sector. This effect occurs if the repeater output is caused to vary inversely with the strength of the receiver signal on a pulse-by-pulse basis. In this manner, little or no output is obtained when the main beam of the radar locks at the target, whereas maximum target output is radiated when the illumination by the radar, due to the sidelobes, is at a low level. Another possible deception is to shift the transmitted signal frequency with respect to that of the received signal. This effect can disrupt the operation of an active system utilizing doppler shift.

#### c. Single-Frequency Transponders

In the simplest configuration, one receiver provides a trigger pulse to the transmitter each time a pulse is received. The transmitter is similarly tuned to the radar frequency and transmits one or more pulses for each trigger input. The number and timing of the output pulses constitutes the deception.

#### d. Search-Lock-Jam-Transponders

In order to have the possibility of simultaneous operation against a number of pulsed radars an arrangement employing very rapid automatic tuning is used, as shown in Fig. 2. The operation is as follows:

The pulsed signal arrives at the receiving antenna and is amplified in a broadband RF amplifier. Then its leading edge is detected and passed through a video



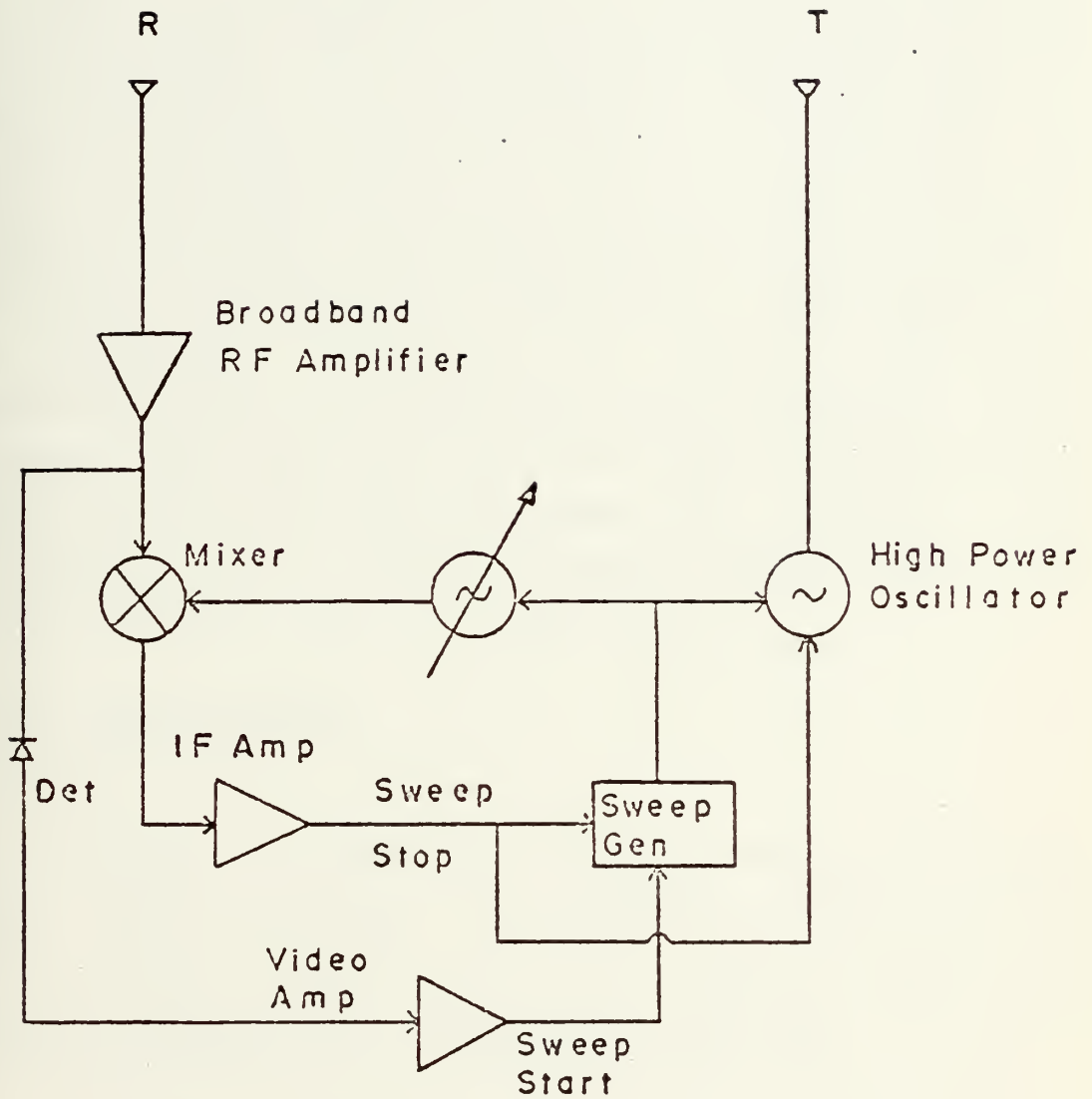

Figure 2 - SEARCH-LOCK-JAM-TRANSPONDER



amplifier to initiate the sweep generator, whose output is applied to two voltage controlled oscillators (VCO). The first VCO is used as a local oscillator to a mixer which has the received signal applied to its other input. The local oscillator sweeps rapidly over the operating frequency range of the equipment until the difference frequency output is within the bandpass of the connected IF amplifier. The output of this amplifier stops the sweep generator and the frequency determining voltage is clamped at this value for a predetermined period. When sweep-stopping occurs, the second VCO, a high power oscillator, is gated on and operates as the transmitter during the stop period. The signal acquisition process just described must be completed during a single pulse from the radar. So, large bandwidths, small delay times and very fast sweep rates are mandatory. This arrangement can be effective against several radars which are looking at the target simultaneously.

## 2. Track Breakers

The track breaking receiver is typically applied in range, azimuth, elevation or velocity against tracking radars. This section will describe a track breaking in angle technique called Inverse Gain Modulation and a track breaking in range known as Range-Gate-Pull-Off.

### a. Inverse Gain Modulation

This deception is especially useful against sequential lobing or conical scan tracking radars.

In such radars the antenna points in the last known direction of the target and its narrow beam is caused to rotate around antenna boresight modulating the echo. When



the antenna is on target the echo modulation is zero. When it is off target the echo return is amplitude modulated as a function of the angle between the target line of sight and the rotation axis. The echo signal will also be modulated at a frequency equal to the rotational frequency of the beam. These modulations are extracted and applied to a servo-control system to reposition the antenna on the target.

The basic idea of the deception is to retransmit pulses that are modulated with spurious amplitudes at the conical-scan frequency. As an example, it can use 180° opposite modulation, that is, when the radar signal increases, the amplitude of the deceiver pulse is made to decrease and vice versa. Since the deceiver pulse is larger than the radar echo, the echo is suppressed by the AGC circuits and the tracking circuits sense only the deceiver-pulse modulation. This, being inverse to the real echo modulation, tends to drive the scan center line away from the target, thus introducing large errors or preventing tracking of the target.

#### b. Range-Gate-Pull-Off (RGPO)

This method is intended against tracking in range based on a split range gate technique, that is, the early-late-gate range-error sensing circuit, described in several radar books.

In this mode of deception, range tracking is broken by retransmitting a sufficiently strong signal to activate the threat radar, and then progressively delaying the transmission of the false range signal relative to the threat signal. So, initially the RGPO just repeats with greater power and with minimum possible delay but when the





radar receiver AGC acts, the delay is gradually introduced. RGPO is most effective against automatic tracking, because the operator can see the false target going away and also still see the small skin echo. There are two types of circuits employed:

- the frequency-memory-loop
- the loopless-memory-loop.

The frequency-memory-loop (FML) system is used to receive, process and store the frequency transmitted from a threat radar, then transmit a false signal after a predetermined delay. Signal flow for a four-level FML system is shown in Fig. 3 [11].

The received signal arrives at the antenna and is amplified by a low noise input traveling wave tube (TWT) where a detector senses the presence of the signal in order to control by means of logic and timing circuits the transmission of the deceptive pulse. After the input TWT the signal is again amplified by the loop TWT, where it is then divided into two paths. One path goes to the intermediate and high power tubes through the output RF switch, while the other is coupled to the time-delay section of the recirculatory memory loop.

After a predetermined delay, less than the minimum pulse width expected, the input RF switch opens and the normally open loop RF switch closes. At this time, the signal continues to recirculate through the loop reproducing the input frequency. After the signal is transmitted a number of times selected by the logic and timing circuits, RF switch action opens the coupled loop path, thus terminating the stored RF signal while preparing the loop to memorize another input signal.

TWTs are key elements since they incorporate



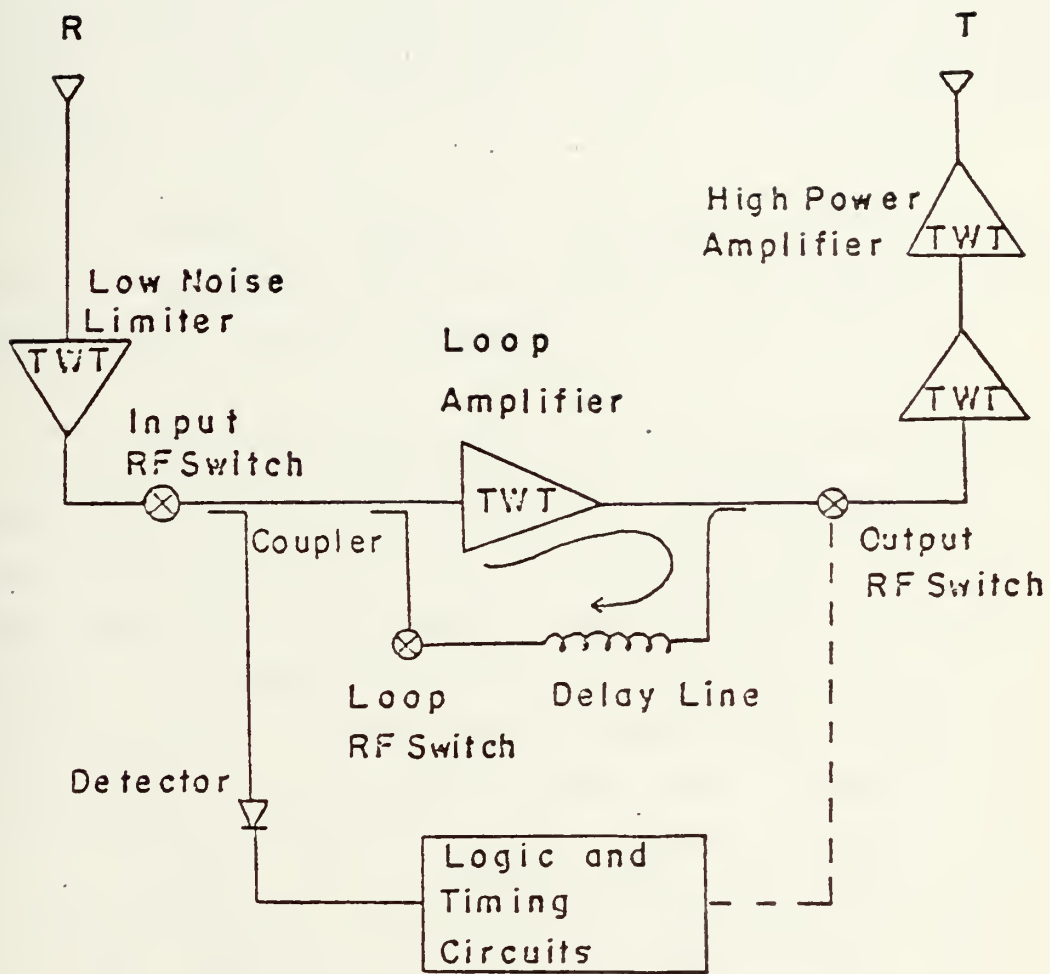

Figure 3 - RGPO - FREQUENCY-MEMORY-LOOP



wide bandwidth and high gain with low noise figure. A more detailed analysis of this component will be presented in Chapter IV.

The delay line can normally be of three types: waveguides, coaxial and acoustic, each one with advantages and disadvantages concerning size and weight, bandwidth capability, cost, spectral purity and loop gain requirements.

Several American companies are developing components suitable for FML among which are Teledyne MEC, Watkins-Johnson, Varian, Raytheon.

The Loopless Memory Loop is a coherent microwave memory using digital storage [12]. A unique memory called Microwave Pulse Storage (MiPS) has been developed by Tasker Systems, Division of Whittaker Corporation and intended to overcome some of the possible deficiencies in existing TWT/delay line memories by using real time digital storage techniques. As for example, since there is no circulation in this approach, there is no noise build up and therefore no signal-to-noise degradation with time. A MiPS memory system can store any RF pulse for as long as necessary eliminating frequency shifts and power dropouts as there are no loop gain variations. It can reconstitute the pulse and output it on demand as many times as required with identical or modified pulses. Basically, as shown in Fig. 4, operation is as follows:

By means of a local oscillator that must be very stable to allow coherence, the incoming signal is down converted to an IF frequency and then quantized. The quantized data is sampled for digital storage at a rate determined by instantaneous bandwidth requirements. For many wideband applications, the frequency of the signal to be



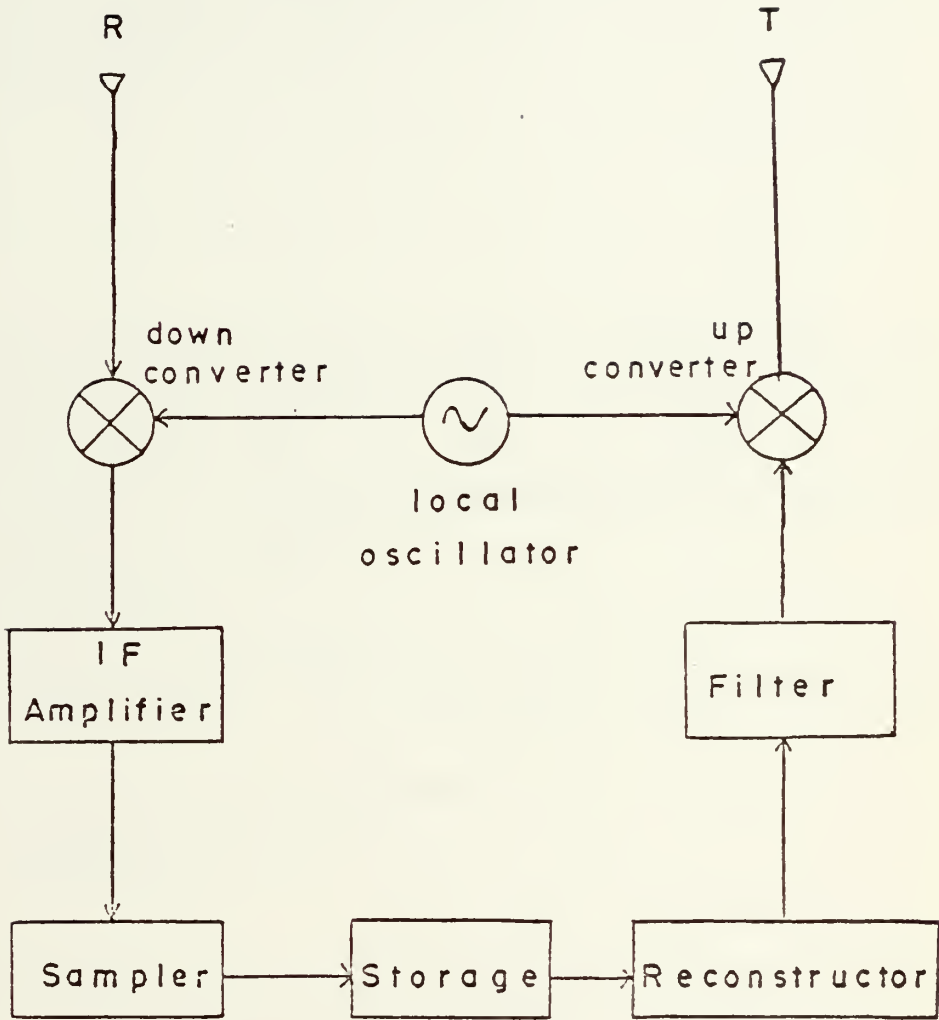

Figure 4 - RGPO - LOOPLESS-MEMOBY-LOOP





acquired is known to a degree of precision requiring much less instantaneous bandwidth than the actual limit posed by current digital storage devices and also, cascaded memories can provide a wide instantaneous capability when required. Upon command, the digital memory contents are strobed out for RF reconstitution.

#### E. DRONES

The use of drones as decoys normally gives a much more realistic false target indication than the methods employing repeaters and transponders. In order to achieve a good simulation the drone must present characteristics similar to the real target with respect to:

- aerodynamics
- radar cross section
- scintillation or variation of this radar cross section
- electromagnetic emissions
- infrared emissions
- appearance.

It can be seen that to obtain all these characteristics the drone is likely to be very complex and expensive. One application where the utilization of sophisticated decoys makes sense is with the strategic bomber aircraft. For this application inclusive the drone can have both an armed and unarmed version to force interception even if enemy radars distinguish the decoys from the bomber themselves. Some examples of drones are:

\* QUAIL, a decoy missile designed to be used with the E-52 with a signature radar similar to it. The payload include ECM equipment and a self-destruct explosive charge.



\* FIREBEE II (BMQ-34E), a supersonic target drone developed for US Navy as an advanced version of the subsonic BQM-34A. The new drone is designed to provide aerial target presentations at around fifteen thousand meters altitude at supersonic dash speeds up to mach 1.5 for a period of several minutes. In addition to the electronic systems necessary for flight it carries the following special equipment:

- AN/DLQ ECM repeater equipment
- X band and C band tracking beacons
- TWT radar augmentation for S, C and X band
- solid state radar augmentation for P band
- passive radar reflectors

\* AQM-34V, a new model of ECM drone for the USAF that is intended to upgrade all Tactical Air Command's AQM-34 drones. Besides the AN/ALE-38 chaff dispenser, it carries jammers in the A, C and E-band, which are respectively the bands of the Soviet acquisition radars for the missiles SA-2, SA-3 and SA-6.

## C. COUNTERCOUNTERMEASURES

### 1. False Target Generators

To put a false target at a distance smaller than the true target, the deceiver pulse must be generated by a time delay from the previous radar pulse. To deny this possibility to the enemy it is sufficient to modulate in certain ways the transmitted train of pulses, such as by varying the PRF or using frequency-hopping. In the former case the echo from a false target will not be stationary, being spread over a finite range, as if it was a



multiple-time-around target. Frequency-hopping, if done with each and every pulse, will not allow these false echoes to appear.

To put a false target at a different azimuth than the true target, the deceiver pulse must enter the radar receiver via antenna sidelobes. Therefore, a good ECCM technique against this is to make the antenna pattern very directional and to avoid sidelobes.

## 2. Track Breakers

The Inversion Gain Modulation technique is especially suitable for the conical scan tracking. Other angle tracking techniques are less or not at all affected by this type of deception [13].

One example is the lobe-on-receive-only (LORO) type of modulation. LORO has a fixed transmitted beam and only the receive beam nutates. This denies the jammer knowledge of the specific scan frequency being used by the radar's receive antenna, forcing the jammer to sweep its applied modulation and thus only periodically be disruptive to the radar angle information.

Another tracking technique relatively immune to this deception is simultaneous lobing or monopulse techniques, that derive angle-error information on the basis of a single pulse. The conventional method uses a four-horn feed if both elevation and azimuth error signals are wanted and is described in several radar books. A new concept however claims the use of a single-horn monopulse feed and the extraction of angle tracking error information is made from the higher modes that are set up in any microwave horn when the signal source is off-axis.



Several configurations of RGPO deception can be avoided, or at least made more difficult, if the tracking is made in the leading edge of the radar echo. Indeed, even when the RGPC is just repeating the radar signal, there is an inherent small delay in the deceiving equipment that makes the false signal appear a little after the true target in the radar receiver. Thus, track cannot be broken if range measurement is made exactly in the initial portion of the signal, where only the true echo is present.

Other techniques, however, can still disrupt the tracking as for example when a chaff rocket is fired forward the target. In this case an ECCM called "guard-gates" is very useful. In this technique gates are positioned immediately preceding and following the original tracking gates, with the function described below, for the chaff rocket example:

When the echo from the chaff enters the leading guard gate the system, if desired, automatically enters a mode of operation called "coast". In this mode the tracking continues following the same stored rate that existed immediately before the deception and proceeds in that way until the clutter appear in the afterward guard gate, when normal operation is then reassumed. If operation in coast mode is not desired, guard gates can be used only as a warning that something is trying to disrupt the tracking, and other measures can then be taken.





#### IV. MASKING JAMMERS

The objective of masking jammers is to obscure or deny information to the enemy by hiding the desired data in interference or noisy signals.

The characteristics and complexity of these denial jammers depend on their use - if against radar, communications or fuzes - and also on the type of device being jammed. In the radar case, for instance, it could be desired to jam a conventional pulsed radar or a more sophisticated frequency-hopping or chirp radar.

Therefore, depending on these factors, certain requisites will be necessary regarding power, bandwidth and modulation. Normally the first two, power and bandwidth, cannot be simultaneously satisfied and this leads to different configurations of masking jammers such as barrage and spot jammers. This will be discussed later.

Often the modulation source selected is noise. An early system, Direct Noise Amplification (DINA), simply used a broadband noise source and wideband high power amplifier. This eliminated the need for modulation of a carrier frequency.

DINA is no longer used due to the small amount of average power, resulting in a very low efficiency. A variation of this type, employing a frequency conversion, was also used with the same deficiencies of DINA.

A third type, amplitude modulation by noise, was still



ineffective due to the fact that most of the power was wasted in the carrier and had a limited bandwidth.

Finally better methods were developed such as frequency modulation by noise. This method has the great advantage of presenting a ratio of Average Power/Peak Power equal to one. However, frequency modulation by noise alone does not give a flat, uniform spectrum. In order to obtain this, other methods were employed: first utilizing as modulating signal a sine wave plus noise and secondly using a sawtooth plus noise. The basic idea is that the shape of the spectrum is approximately equal to the probability density function (p.d.f.) of the modulating signal. The approach is then to try to change the p.d.f. of noise from Gaussian to Uniform. This can be done by using a non-linear amplifier whose input-output characteristic is described by the error function. For this reason this system is called "erfer". In practice, the implementation of this process is not too difficult to obtain.

Denial jamming can be classified according to the ratio of the jamming signal bandwidth to the acceptance bandwidth of the victim radar. If the ratio is large, the signal is called barrage jamming. If the ratio is small the signal is called spot jamming.

Barrage jammers, therefore, are wideband noise transmitters designed to deny use of frequencies over wide portions of the electromagnetic spectrum. The great advantage is that it is possible to jam simultaneously several enemy receivers or jam the entire range of frequencies of a frequency-hopping radar without tuning the transmitter.

Spot jammers are narrowband, tunable transmitters used to mask specific systems. In this case, the complete jammer



system normally consists of a receiving antenna and reconnaissance receiver, a power management circuit and the jammer transmitter with antenna. In some other types of systems the functions of the receiver and the transmitter are decoupled and an operator links the two.

A "lock-through" capability is desirable in order that the jammer may be kept on the frequency of the transmitter to be jammed and also to know if the transmitter is still radiating.

The chief advantage of spot jammers is the fact that their output is concentrated in a narrow spectrum and therefore greater distances of effective jamming can be obtained as compared to barrage jammers. Or, conversely, for the same distance the spot jammer requires less power and thus could be smaller and lighter.

#### A. TRANSMIT TUBES

One can deduce from the above considerations for masking jammers that the transmit tube is of considerable importance. It can even be said that the study of a transmitter is basically the study of the tube used. In agreement with this it can be observed that it is not common to find as many advertisements by manufacturers of transmitting equipment as are found for the other specialized EW equipments, such as receivers. On the other hand there are many advertisements concerning the characteristics of the tubes and associated microwave devices. In order to reinforce still more the idea it is worthwhile to point out that the US Department of Defense will boost research and development funding for microwave tubes and solid-state devices by as much as 20% annually in



coming years.

The basic need of these devices is normally high power but other requirements must also be met:

- wide bandwidth
- modulation capability
- efficiency
- reduction in power requirements
- high gain
- multiple-threat handling capability
- low cost
- long life
- reliability
- small size and weight. This last characteristic

is very important especially for airborne use where the limited space available leads to restrictions in the number of EW equipments. For this reason, the manufacturers developed one tube and power supply suitable for use in both masking and deception jamming transmitters. This means that it is highly desirable that the tube works efficiently in both a CW and pulsed mode of operation. This is called DUAL-MODE operation. A desirable specification is to have dual-mode pulse-up of 10 db minimum (pulse on top of CW in a single tube).

Also, sometimes, due to the tactical application, one of the above characteristics becomes increasingly important. For example, in stand-off jamming, where normally it is necessary to jam through the sidelobes and not the main beam, power becomes crucial. For expendable systems probably cost and size, besides power requirements, are the key factors.

The more used tubes include klystrons, cross-field amplifiers (CFA) and traveling wave tubes (TWT). The latter seems to be gaining the preference of the EW community and





will be used as basic to the following discussion of some of the more important characteristics [14]. The others will be covered later.

#### \* Bandwidth

Until recently a typical band covered by jamming systems ranged from 0.7 to 18 GHz. Today the tendency is to extend this upper limit to 40 GHz. Indeed, it is expected that the region of the spectrum from 18-40 GHz will see increasing use as the evolution of technology permits development of new components. Again, it is just a matter of picking a microwave advertising catalogue and seeing how the trend has moved toward filling the 18-40 GHz region requirement.

In order to reduce the number of tubes and associated circuitry necessary to cover all this range of frequencies, the widest instantaneous bandwidth with no tuning requirement is in principle desired. At present, the TWT with its helix slow-wave structure is capable of octave and sometimes multi-octave operation.

#### \* Power

Power is a function of the frequency that the tube is designed to work at. For the TWT, typical numbers in the CW mode range from 600 watts at the lower end of the region to 200 watts at the higher frequencies. In the pulse mode the variation is from three to two kilowatts peak power.

In applications where greater power is needed - and with today's ECCM improvements this often occurs - one can employ tubes in a parallel arrangement with the additional advantage that the failure of one tube does not necessarily end the usefulness of the system. However, there are problems when trying to combine in parallel the output powers of several tubes: relative phase changes between the



tubes and component compatibility, generally introduce a combined efficiency reduction.

#### \* Life and Reliability

Especially for shipborne use, due to the duration of the missions, the life of the TWT could result in one of the biggest supply headaches for EW maintenance. An excessive number of spares must be carried to face the low MTBF of some older models, with an operational filament life of a few hundred hours.

#### \* Gain

The gain of the transmit tube reflects in the characteristics of the driver stage. If the gain is not high enough, it requires a more powerful driver and the consequent implications of cost, size, weight. TWTs have a gain in the order of 30 to 60 db and powers of less than one watt are required to excite them.

#### \* Modulation Capability

Tube modulation for ON/OFF gating is required for lock-through capability. A smooth transition between ON and OFF is desirable and the faster the modulation rate, the better its usage in the overall system. TWTs often have low current electrodes which can be used for modulation, requiring low power.

Finally, a brief discussion in the other two tubes, the CFA and the klystron.

CFAs typically have two-thirds of an octave as their instantaneous bandwidth and can be electrically tuned to octave bandwidths, although this increases complexity to the overall system. They can also be easily modulated for



lock-through.

CW CFAs are not yet available in all bands. However, it must be pointed out that they are not as developed as the TWTs, and when funds are provided to advance the technology new improvements will be discovered. It is currently supposed that the Russians give great importance to the CFA.

Klystrons are high power, high gain, high efficiency devices. However, generally only useful for narrowband applications. Their instantaneous bandwidth is 1% of an octave and they can only be tuned over a bandwidth of up to one-third of an octave, and by a slow mechanical process. They also require a large cathode modulator to obtain a lock-through characteristic.

Several other microwave devices are presently in an early phase of development, research or initial production for EW applications, such as the gallium arsenide Impatt devices, the gallium arsenide FET, varactor-tuned oscillators, special types of parametric amplifier and YIG filters.

## B. HIGH POWER JAMMERS

The first generation of masking jammers was of the CW Power Oscillator type, using magnetrons or backwave oscillators as transmit tubes.

As an example of this type there is the ALQ-76, an airborne pod-mounted jammer delivered by Raytheon Company, USA, and used in the EA-6A of the Marine Corps. It is a manually controlled CW noise jammer in the bands C to J with both spot and barrage capability. In this type of system,



the operator uses the warning receivers to determine threats frequency and direction. Then he tunes manually the transmitter, selects desired jamming bandwidth and also positions the jammer's directional antenna.

Another generation started with the shift toward the Master Oscillator Power Amplifier (MOPA) approach, that provides better versatility and effectiveness.

A typical system is the ALQ-99 designed to be the Tactical Jamming Transmitter of the EA-6E, the Navy's EW aircraft. The driver stage that feeds the output TWT is a low-level RF oscillator modulated by a digitally controlled signal generator, the Exciter. This receives its information from an onboard computer that processes data from warning receiver outputs and operator commands. The steerable antennas also are oriented automatically by the computer. An onboard modification of the ALQ-99 system is now being developed to be used in the EF-111A, the USAF counterpart of the EA-6E.

Raytheon Company also delivered recently to the US Air Force a test model of a jammer employing a CFA tube, in the bands G-H-I.

### C. COUNTERCOUNTERMEASURES

#### \* Pulse Compression [15]

This is a technique that is basically intended to increase the average power of the radar. The way this is done results in a reduction of the required signal-to-noise ratio by a factor called the dispersion factor  $D$ , meaning that the radar becomes less vulnerable to interfering





signals and jamming.

Pulse compression involves the transmission of a long coded pulse and the processing of the received echo to obtain back a relatively narrow pulse. This process, elongating the pulse but maintaining its spectrum bandwidth large, gives the desired increase in power - the pulse is elongated - maintaining the characteristics of range discrimination due to the wide spectrum.

There are several ways to generate these pulse characteristics. The linear FM or "chirp", is the easiest to generate and, because of its great popularity, more devices for generating and processing linear FM have been developed than for any other coded waveform.

The transmitted waveform consists of a rectangular pulse of constant amplitude  $A$  and duration  $T$ . The frequency of the transmitted pulse increases from  $f_1$  to  $f_2$  over the duration of the pulse. The frequency-modulated echo received by the radar is passed through the pulse compression filter that speeds up the higher frequencies at the trailing edge of the pulse relative to the lower frequencies at the leading edge, compressing into a shorter pulse of duration  $1/B$  where  $B=f_2-f_1$ . The above mentioned dispersion factor  $D$  is equal to  $ET$ .

Another way to do pulse compression is by phase-coded waveforms. Here, the long pulse is subdivided into a number of shorter subpulses each transmitted with a particular phase, selected in accordance with a phase code, normally binary. Upon reception the compressed pulse is obtained by either matched filtering or correlation processing. The compression ratio is equal to the number of subpulses in the waveform.



### \* Duplexing

This is one mode of frequency diversity where two frequencies are used and the better signal of the two receivers is taken. So, in order to be effective, the enemy must jam both frequencies.

### \* Frequency Hopping

If a radar keeps changing frequency, a spot jammer can be easily countered forcing the enemy to spread his energy in a wide band due to the impossibility of knowing the next frequency.

As an example, in a satellite communication link it takes 0.25 second for the earth station - satellite - earth station trip. So, hopping frequency four times a second will deny the spot jammer access to the link. In radar applications, with the new tubes available, it is possible to change frequency at every pulse.

### \* Maximum suppression of sidelobes

The stand-off method of jamming normally transmits using the sidelobes of the jammed target. If these sidelobes are kept small, extremely high power must be used in order that the jammers can stand at a safe distance.

### \* Spread Spectrum

In this technique a wideband noise-like signal is generated by a shift register and viewed as a carrier on which the message is imposed. At the receiver, an identical shift register noise generator, synchronized to the one at the transmitter, generates the same code that is subtracted from the incoming signal, reconstituting the information. A spread spectrum signal may be used at a low detection level



and occupy a very large bandwidth simultaneously with several other spread spectrum signals, each having a different pseudo-random noise code.

If there is a jamming signal that does not have any correlation with the code, when de-spreading at the receiver, the spectrum of this jamming is spread and then diluted. So, against a link using spread-spectrum, the best jamming is, in principle, the one that has the narrowest spectrum, that is, CW jamming. However, a notch filter can completely nullify the effect of the CW jammer and sometimes a broader spectrum is also useful.



## V. INTERCEPT RECEIVERS

### A. UTILIZATION IN ELECTRONIC RECONNAISSANCE

Intercept receivers are used in Electronic Reconnaissance, an integral part of Military Intelligence. Electronic Reconnaissance (ER) is one of the basic methods for obtaining information about parameters and disposition of hostile electronic devices and their coordinates. Although sometimes just a matter of nomenclature it is possible to recognize some subtle differences among three classes of ER [16]:

- \* ELINT (Electronic Intelligence)
- \* ESM (Electronic Support Measures)
- \* RBAW (Radar Homing and Warning)

ELINT is the collection of data accumulated during long periods of time and leads to an almost complete knowledge of the characteristics of the electronic capability of the enemy. It is essential in order to permit a precise development of one's own equipment, to counter, or to avoid being countered by the enemy's electronic systems. There is therefore sufficient time to record, analyze and compare the information obtained.

ESM relates to tactical knowledge and thus the value of the information must be current. The collection time is not as long as in ELINT and the analysis must be available quicker, perhaps real time, thus permitting to be known what





equipments are being used by the enemy and allowing the preparation or modification of the ECM plan.

RHAW is more pertinent to aircraft operations where the detection of threats, analysis and actions must be taken almost automatically, obeying a built-in or programmed plan of action.

Therefore, due to the different missions, it is expected that the equipment employed in ER varies greatly from the one carried in a helicopter to one aboard an electronic reconnaissance aircraft or to those that are shipborne installed. The basic features remain the same however, and differences only will be pointed out when their impact results in completely different approaches.

The principal function of the intercept receiver is therefore Military Intelligence. The basic idea is to provide information in the minimum time on the existence and characteristics of various signals. Several answers might be representative of what is expected to be gained from an intercept receiver. Regarding the strategic and tactical point of view, for instance, the following information is of interest:

- location of defenses of the enemy systems
- area of coverage of this defense
- hours of operation and methods of usage
- mobility, capability, saturation characteristics and reliability of the defense systems.

Technical intelligence varies according the type of the system of the enemy. For a radar system, for instance, the following parameters are normally of interest:

- frequency of operation
- pulse width
- pulse repetition frequency



- antenna characteristics
- power output

Besides these parameters, electronic signals also have certain specific features which are peculiar to them, such as form of pulse, form of radiation pattern, polarization, bandwidth, RF coherence.

## B. BASIC CONFIGURATIONS

The Intercept Receiver used as an electronic support equipment normally differs from the common receiver in several ways:

\* absence of a priori information - Several types of receiver know in advance the characteristics of their signal. This is the case of the radar receiver where the echo format is basically the same of the transmitted signal. By contrast, in the intercept receiver the operation is completely blind in the majority of the cases without previous knowledge of the electronic characteristics or the location of the source of signal. This lack of a priori information makes it more difficult to utilize circuits for integration techniques and thus the consequent improvement factor on the signal-to-noise ratio is not available.

\* wide frequency bandwidths and large dynamic ranges - Intercept receivers must cover many octaves and since components and technology are so different in these diverse bands, it is like having several receivers in one. The dynamic range also is enormous. Due to the one-way transmission, signal levels could be very high but on other occasions it may be necessary to intercept a low power transmission via radiation from secondary lobes and high sensitivity is mandatory.



\* complexity of signals characteristics and presence of false targets - The enemy will try by all means to avoid detection or to being countermeasured. He will not only make use of deceptive techniques but also his signals will frequently be subjected to programmed or even random variations in character during a transmission period.

The more important operational requirements of intercept receivers are good sensitivity, high probability of detection for signals above threshold and small time for detection. These requirements, in principle, are opponents. As an example, if the receiver has its front end "wide-open" this assures instantaneous 100% intercept probability for signals above threshold, considering omnidirectional reception. The threshold level is however high because the system is also wide-open to noise and thus the sensitivity deteriorates. Besides this, making the receiver omnidirectional loses azimuth information. A possible way to handle these problems of antagonism between the requirements is to maintain a high probability of detection and improve the trade-offs by using a second configuration of receiver.

With all these factors influencing design there are different types of intercept receivers each one with its limitations, advantages, trade-offs and compromises.

#### 1. Crystal Video Receivers (CVR)

This type of receiver consists of a diode detector (crystal) followed by a wide-open video amplifier, generally with a logarithmic characteristic. In this basic configuration it does not permit frequency measurement, except within the bandwidth of the antenna waveguide and



crystal characteristics. It can be used to determine other parameters of the signal such as PRF, pulse width and pulse amplitude. Its greatest advantage is simplicity allied to a good dynamic range, stability and high probability of detection for signals above threshold. The CVR is therefore useful in applications where complexity, space and cost are restrictive considerations and for early warning applications.

## 2. Instantaneous Frequency Measuring Receivers (IFM)

The IFM receiver has a broadband, wide-open characteristic that allows simultaneous measurement of the instantaneous frequency of all in-band signals, that is 100% probability of interception for signals above threshold [17].

The key component in providing this capability is normally a broadband microwave solid-state stripline phase discriminator. The discriminator output consists of video signals that are a function of the amplitude and instantaneous frequency of the received signal. The video signals, appropriately combined as shown in Fig. 5, are then applied to orthogonal plates of a CRT display. In the case of a CW or pulsed input signal with constant frequency and amplitude, the presentation in the CRT has the form of a dot with radial distance to the center of the scope proportional to input power of the signal and angular displacement proportional to its instantaneous frequency.

The fact that the measured frequency is the instantaneous frequency implies that there are no sidebands displayed as in a spectrum analyzer and therefore sideband components of a strong signal cannot mask weak signals close in frequency. A typical IFM receiver can resolve two





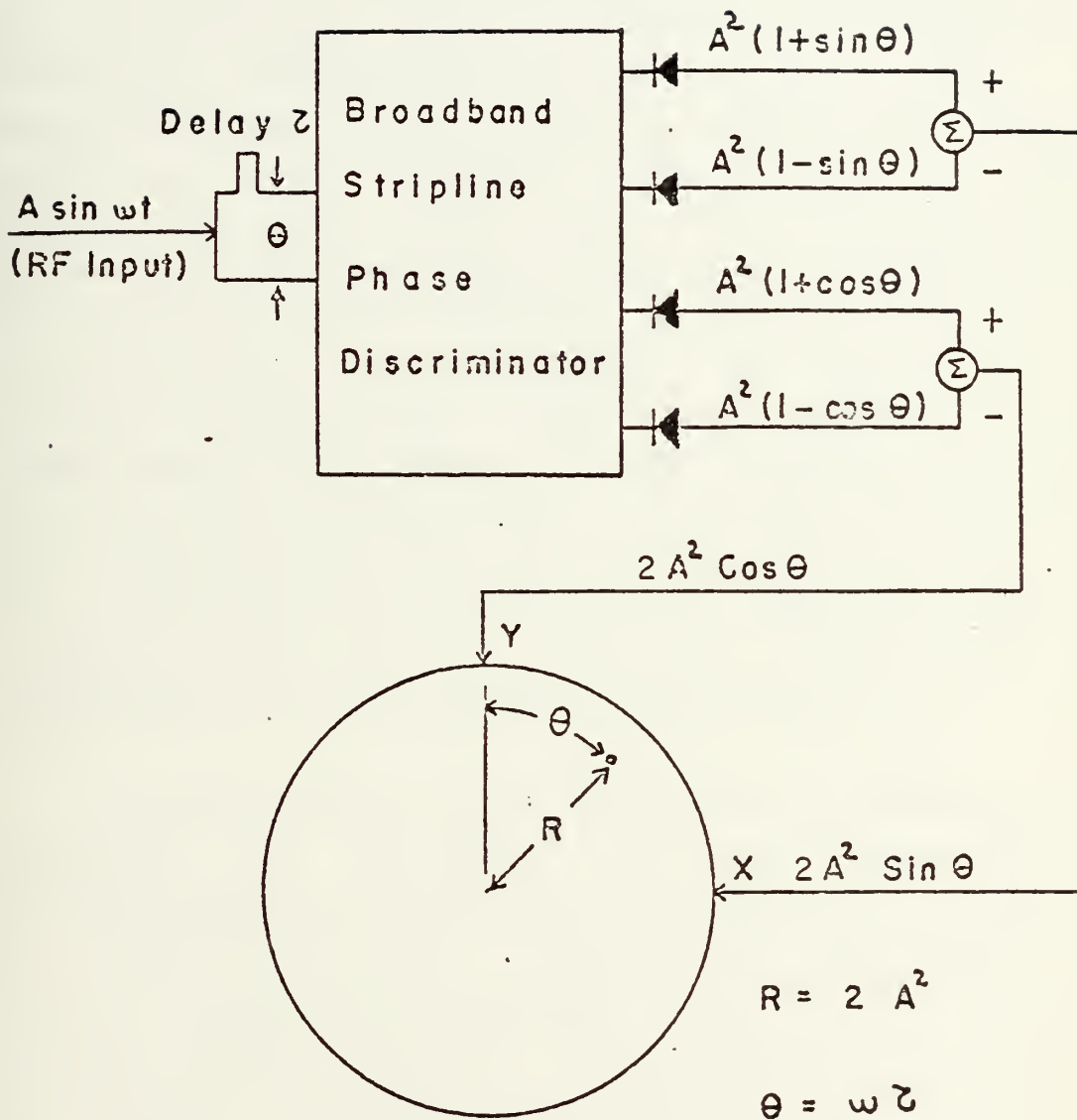

Polar CRT Display

Figure 5 - IFM DISCRIMINATOR



signals separated in frequency by 5 Mhz. This high resolution is very important because operational environments are frequent where signals tend to "stack up" in certain regions of the frequency band. IFM receivers are also advantageous for acquiring and recognizing sophisticated frequency-agile radars such as chirp or frequency-hopping radars. Figure 6 presents an IFM polar display and several possible configurations of radar signals. The first signal (1), at 8.2 Ghz, has a fixed amplitude and frequency (characteristic of a tracking radar that is locked on the receiving platform) as shown by the dot on the display. The second signal (2) has a 200 Mhz intrapulse frequency shift (chirp) that is characteristic of a pulse-compression radar. The third signal (3) is a pulse-to-pulse frequency-agile radar that jumps randomly among 8 frequencies within a 500 Mhz band (9.5-10 Ghz). The fourth signal (4) has a pulse-to-pulse amplitude modulation as shown by the almost continuous trace. This is characteristic of a conventional search radar.

The IFM receiver as presented above is basically an acquisition and continuous monitoring receiver. For additional analysis concerning other parameters of interest such as PRF, pulse width, coherence (to distinguish a MTI radar) the IFM is usually coupled to a narrowband analysis receiver. Signal sorting for analysis can be made automatically or by means of an operator controlled Angle Gating circuit (cursor), adjustable regarding width and angular position. In the same Fig. 6 the gate is shown as dashed lines bracketing signal (1).

### 3. Conventional Superheterodyne Scanning Receivers

The conventional frequency scanning type superheterodyne receiver consists of a mixer, a scanning



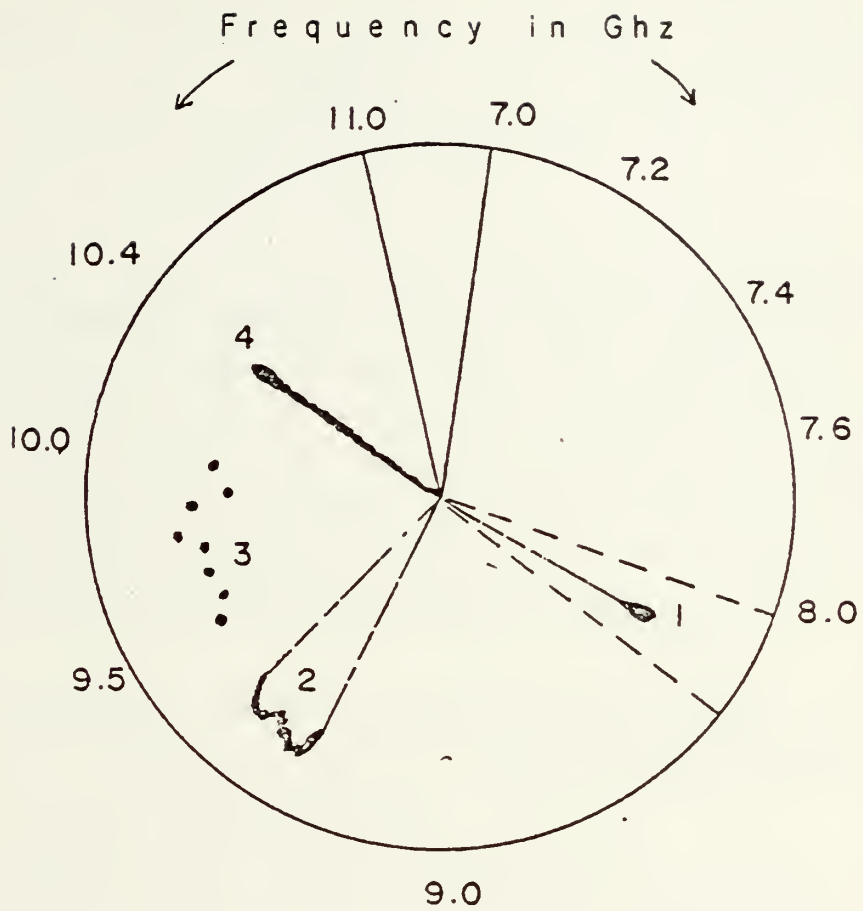

- 1- tracking radar
- 2- chirp radar
- 3- frequency hopping
- 4- search radar

Figure 6 - IFM PCLAR DISPLAY



local oscillator and an intermediate frequency bandpass amplifier, as shown in Fig. 7a. The local oscillator is scanned through a frequency range sufficient to cause a difference frequency component to scan through the intermediate frequency band for any signal in the input frequency band, as shown in Fig. 7b.

In these receivers the time required to achieve a specified intercept probability varies inversely with the duration of the scan associated with the probability of intercept per scan. This latter is very reduced if one tries to obtain at the same time multiple parameters such as azimuth and frequency. Therefore the basic mode of operation for scan receivers is normally limited to the scanning of frequency, while using omnidirectional antennas [18].

The parameters defined below and also shown in Fig. 8 and Fig. 9 will be helpful in the following discussion concerned with some types of scan:

- \*  $T$  - signal pulse repetition interval
- \*  $T^1$  - antenna scan period
- \*  $T_{\bullet}$  - duration of the train of pulses at the receiver (illumination period)
- \*  $T_c$  - maximum time possibly necessary for detection of the signal
- \*  $T_r$  - receiver scan period
- \*  $A$  - acceptance band of receiver
- \*  $D$  - sweep bandwidth of receiver

The first scan-receivers were of a manual Slow-Scan type, that is  $T_r \gg T^1$  as shown in Fig. 8a. It can be verified that, in this case,  $T_r A/D$  must be greater than  $T^1$  for 100% intercept probability and  $T_c = T_r$ . Therefore, in order to minimize  $T_c$ , the ratio  $A/D$  should be increased with the trade-off of poorest sensitivity of detection due to the





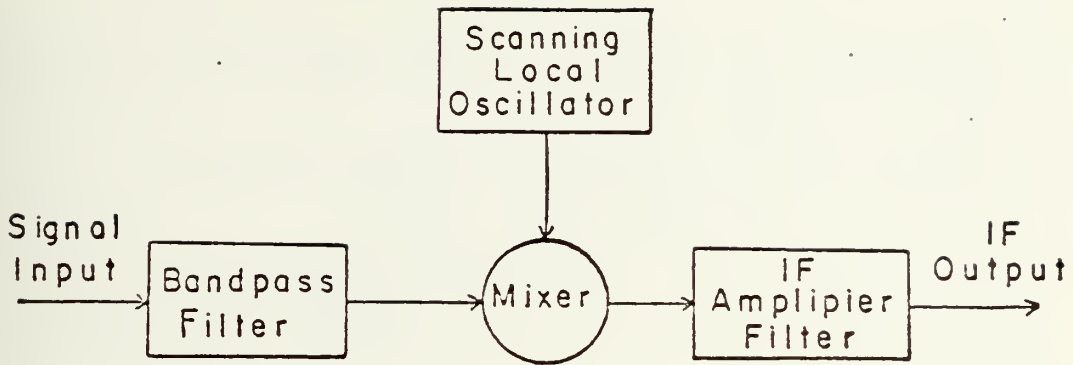

(a)

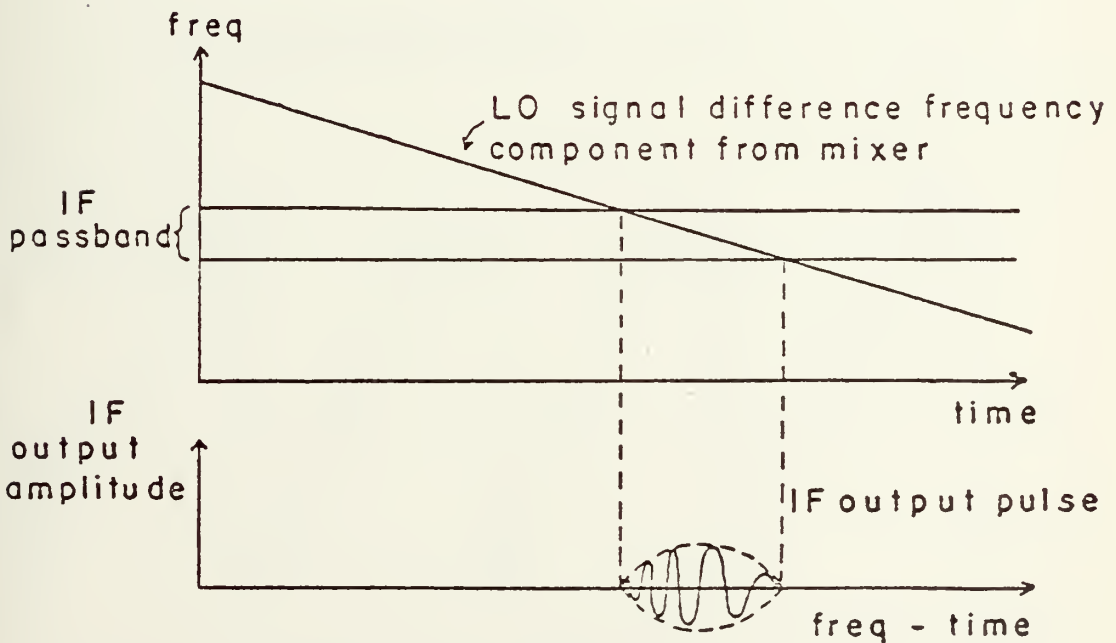

(b)

Figure 7 - CONVENTIONAL SCANNING SUPERHETERODYNE RECEIVER



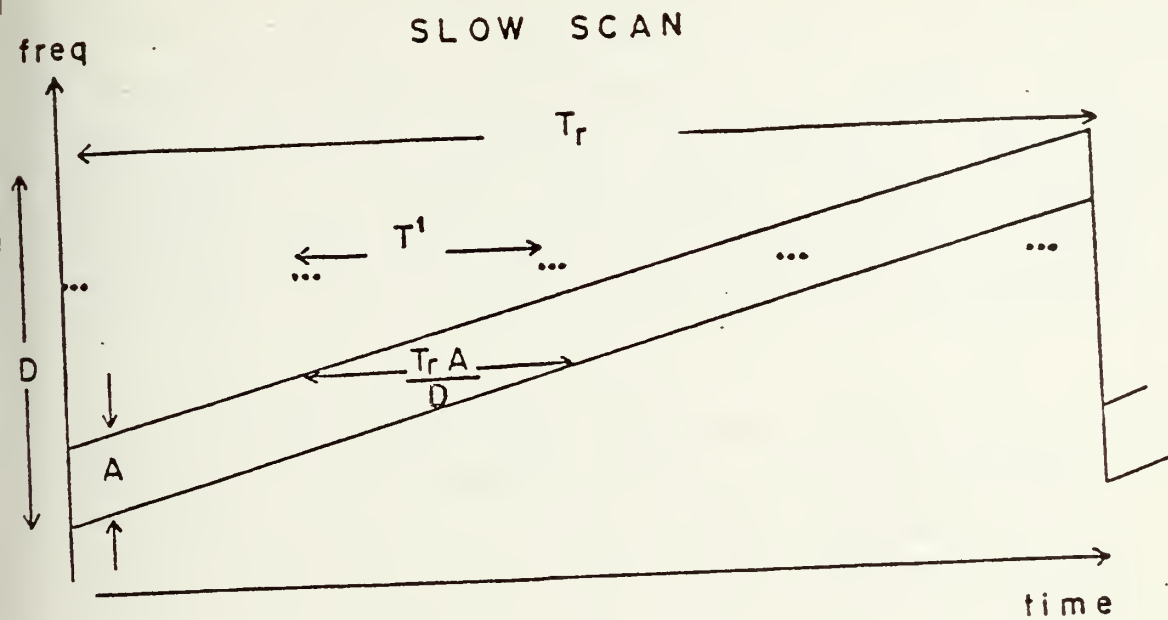

(a)

INTERMEDIATE SCAN

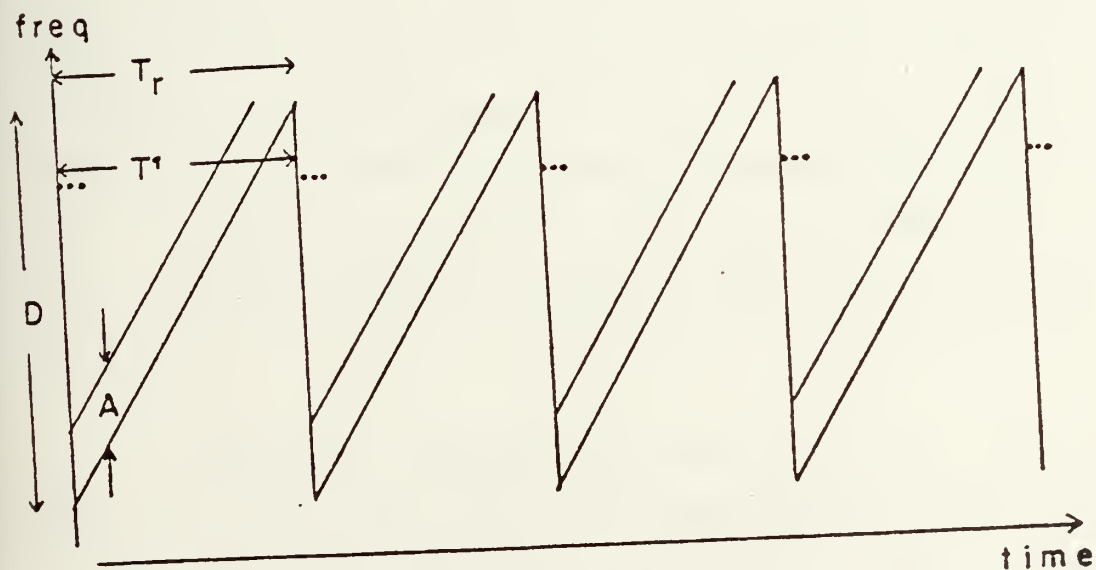

(b)

Figure 8 - a) SLOW SCAN    b) INTERMEDIATE SCAN



fact that the receiver is becoming wide-open. The maximum possible value for this ratio is unity. In this situation there is of course no sweep and it is similar to the CVR case. Another problem in increasing the acceptance bandwidth  $A$  is that this implies poorer resolution of signals close in frequency, because of the increased time duration of the IF output pulse, as can be deduced from Fig. 6a.

Intermediate-Scan receivers result if the speed of scanning is increased so that  $T_r$  becomes comparable to  $T^1$ , as shown in Fig. 8b. This figure presents exactly the adverse situation in which interception is very unfavorable due to the closeness of synchronism between the rotation of the radar antenna and the scanning of the receiver. Intermediate-Scan receivers are subject to inconsistencies and therefore probabilistic in nature.

Rapid-Scan receivers are characterized by  $T_r \ll T^1$  or, this is to say,  $T_r$  is comparable to  $T_s$ , as shown in Fig. 9a. In each scan at least one pulse of the train will be certainly intercepted provided that  $A > DT/T_r$ . Because normally only a few pulses or even a single one may be intercepted in each sweep, certain parameters of the signal, such as the PPF, are difficult to obtain during the normal scan period. Therefore, for a more complete analysis, a dwell-type operation is commonly alternated with the scan period.

Microscan receivers, as shown in Fig. 9b have  $T_r$  decreased still more until it becomes smaller than the pulse width. In this situation, each and every pulse is intercepted however this advantage is not obtained for free. Indeed, intercepted pulse segments, being narrower, require increased video bandwidths with consequent increased noise effects. Similar to the rapid-scan receiver, for a complete



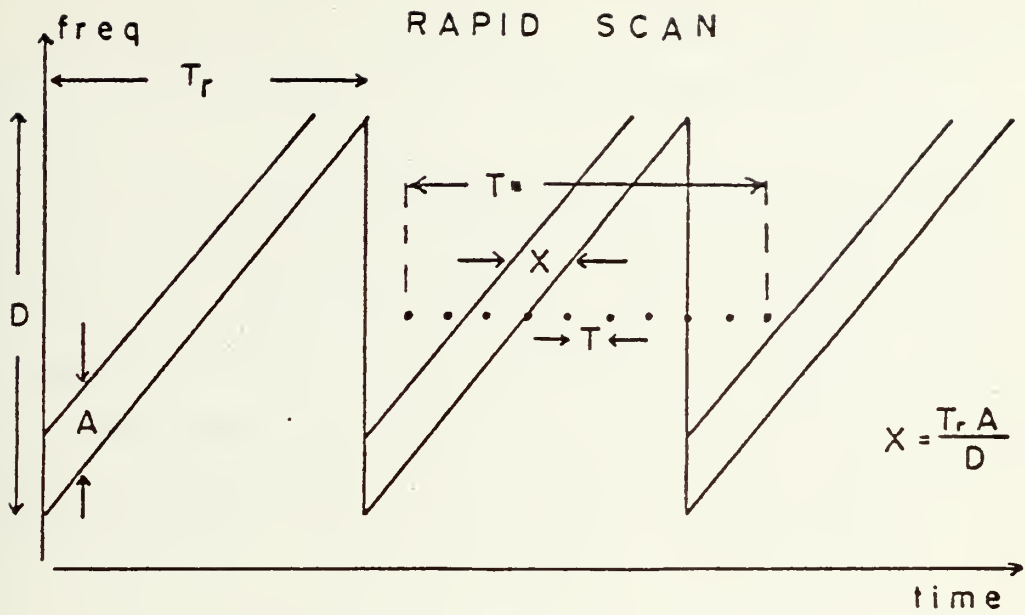

(a)

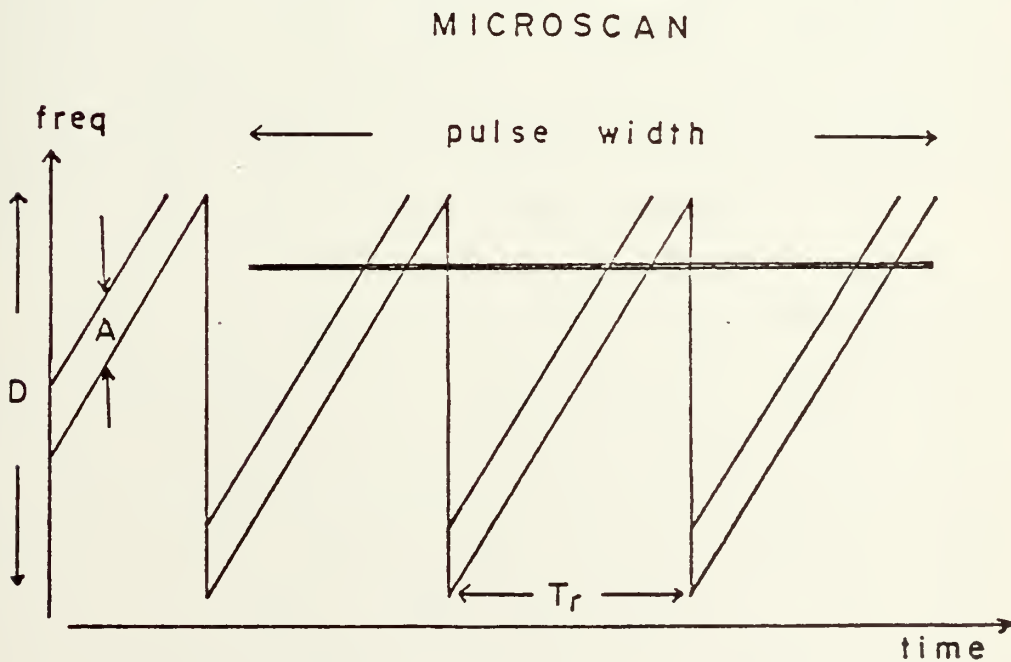

(b)

Figure 9 - a) RAPID SCAN b) MICROSCAN





analysis of the signal parameters, including now the pulse width and chirping frequency, a dwell-type operation is commonly alternated with the normal sweep period.

It must be pointed out that the above discussion is concerned with the basic format of scan receivers. Several techniques of signal processing have been employed to improve the trade-off results indicated above. One of them uses dispersive delay lines as IF filters. These receivers, known as Compressive-Receiver, are related to chirp radars in which a dispersive filter is used to compress a linearly frequency-modulated pulse into a much shorter pulse.

#### 4. Compressive Receivers [19]

Pulse compression, as applied to modify conventional superheterodyne scanning receivers, has several interrelated advantages. By analogy with the radar application, it basically improves resolution, that is, the receiver's ability to distinguish between signals closely spaced in frequency, and also the related ability to detect small signals in close proximity to large signals.

The improvement in resolution is obtained without decreasing the IF bandwidth and this fact reflects as a better probability of interception without loss of sensitivity. A conventional scanning receiver, in order to have the same resolution and sensitivity, would be required to scan much more slowly, drastically reducing intercept probability on short pulse emissions or, if they are repetitive, prohibitively increasing the time of detection.

The pulse compression receiver takes advantage of the fact that the IF output pulse, as can be observed in Fig. 7, is frequency modulated because of the scanning local



oscillator. The frequency-dependent delay of the compressive filter is adjusted so that the beginning of an IF output pulse is delayed a length of time equal to the duration of the pulse. Intermediate portions of this pulse are proportionately delayed a lesser time, the result being that all the signal energy tends to emerge from the compressive filter at one instant. Because this tendency toward instantaneous response is bandlimited, the output pulse has a finite duration and its shape is the Fourier transform of the IF bandpass shape. Thus, this compressed pulse duration is approximately the reciprocal of the IF bandwidth. Although there are other considerations involved, it can be seen that in principle an increased IF bandwidth is desired and this is advantageous for the probability of interception.

## 5. Channelized Receiving Systems [20]

The channelized IF or Contiguous Filter Bank Receiver is basically intended to combine the sensitivity and frequency resolution of the superheterodyne with the high intercept probability of wide-open CVR or IFM. A typical channelizer system block diagram, as shown in Fig. 10, is a superheterodyne receiver with an IF two gigahertz wide, the scanning of the total band 0.5-18 GHz being therefore exceptionally fast because of this large instantaneous bandwidth. The IF is then subdivided by filters into 20-100 channels separately detected and amplified by its own video amplifier. Simultaneous signals, if separated by more than a filter bandwidth are separately detected, tagged and reported with the channel number. If two or more signals are in a filter band, a vernier channelizer used in series can resolve pulse frequency to about 3 MHz. If automatic recognition of radar type is desired, digital encoders are added and shared among the channels. The



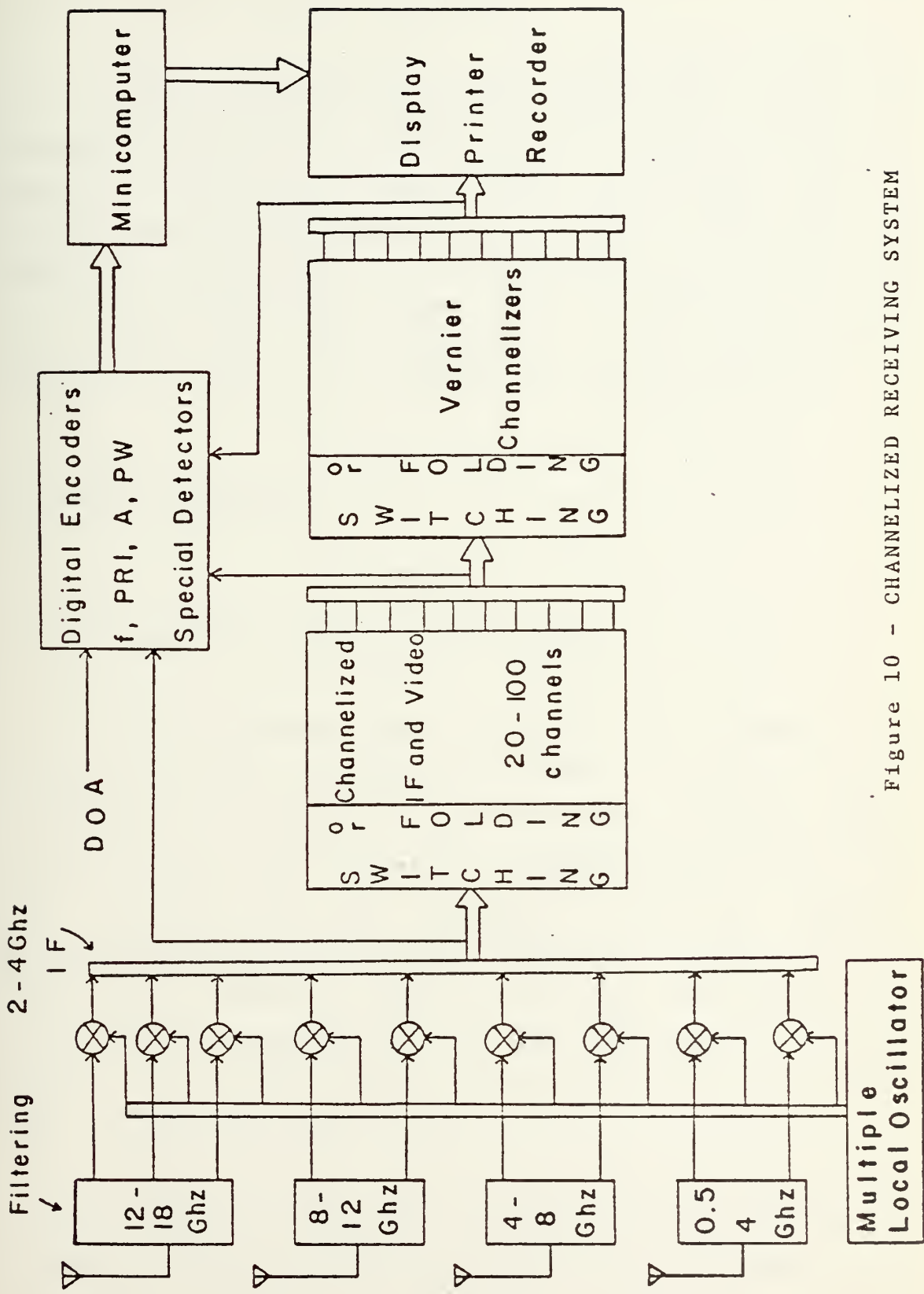

Figure 10 - CHANNELIZED RECEIVING SYSTEM



encoders transform the detected video pulse into a multibit digital word for further processing.

Channelized receivers are typically used to cue or set a superheterodyne analysis receiver onto a signal of interest or accurately set a jammer transmitter onto a signal to be jammed. Their cost-effectiveness and size depend on the mechanization of the IF filter bank and the complexity of the video data processing circuits that follow it. One key element that allowed putting all these channels in parallel was the development of new manufacturing processes concerned with microwave integrated circuits.

## C. SIGNAL PROCESSING

### 1. Computers in Electronic Warfare

The discussion that follows will assume the existence of highly sophisticated threats. This is of course not only a valid but necessary assumption. However before proceeding it should be kept in mind that sophisticated threats are also more expensive, complex, larger, and thus not carried by all platforms. As for example, frequency-hopping or PRF-varying radars are certainly more difficult to detect, identify or jam than conventional pulsed radars. However, the great percentage of radar systems are of the latter type - and it is expected to remain that way for some time.

Processors for these simpler types of threats are naturally easier to implement. They are not only useful for countering several actual equipments but also possess some basic features which are the starting point for more complex





systems. With this idea in mind, Appendix A discusses the essential requirements of a circuit intended to measure the PRF and PW of a conventional pulsed radar. Emphasis is placed on how to cope with the problem of unsynchronized arrival of the train of radar pulses due to antenna rotation.

Modulated PRF certainly requires a much more complex signal analysis. Indeed, these sophisticated threats made hard-wired processors virtually useless for their recognition or identification.

Another problem is that unfortunately a processor must handle more than one signal at a time. Indeed in the modern EW environment an incredible rate of 100,000 pulses per second per RF band could be present.

The demand for better programmability as well as greater capability has resulted in an increased use of the computer in an EW environment [21]. In addition, the cost of memory elements has been significantly reduced as compared to hard-wired logic elements.

In a typical computer based system the various threat parameters are stored in the computer memory, thus creating a comparison library readily updated by a software change. The system logic also can be stored in the memory taking advantage of software techniques. As an example of the use of the computer, the same PRF measurement problem could be attacked in the following way:

The time of arrival (TOA) of each pulse is digitized and entered into computer memory. The identification program selects a TOA and adds to it the PRI of interest. A search is then made of the remaining data to determine if another pulse exists at, or close to, the new TOA. If a hit is



obtained, the process is repeated until sufficient pulses are located for a positive identification to be made. If the pulse train is not identified, a new start pulse is selected and the process repeated.

In addition to signal processing the computer can perform control functions such as implementation of optimum scan patterns programmed to vary as a function of the received environment. The kind of control function greatly varies with the intended use of the receiver. Indeed, as was pointed out before, Intercept Receivers have such varied characteristics that it is hard to generalize. In some applications for instance there is a general purpose computer shared among several systems - navigation, command, weapons - while in other configurations the computer is specialized and dedicated exclusively to the EW equipment. A possible classification when analyzing the role of the computer in EW is to consider its functions in ESM, ELINT and RHAW. Due to some peculiarities, it is worthwhile to take a brief look of the latter.

#### a. RHAW Mini-Computers

Complete automation of a system is not always the ideal mode of operation. Indeed, in several situations, a skilled operator is very helpful in data interpretation or decision processes. In airborne applications however, operators are only present in certain types of aircraft and thus, in order to minimize pilot load, automation is a must. To achieve this and other goals, the new generation of RHAW systems was designed to make extensive use of mini-computers.

At the beginning of this decade, companies worked with available militarized digital processors but



these were too slow for most EW scenarios. Then they decided to build their own computers, tailored to better fit the EW increasing requirements. As for example, it was soon felt that the function of radar warning by itself was not enough and great importance was attached to a complete integration with jamming and weapons launching.

The computer then, besides having application to the control and signal processing alone, was charged with important functions in this integration. This is known as Power Management. As defined, Power Management is the smart application of jamming power on a threat priority basis at the right time, on the right frequency and polarization and in the right direction.

Some features of these new vintage RHAW systems provided by the mini-computer multiple roles are:

- known friendly emitter signals or signals of low interest are eliminated by either pre-programmed instructions or by operator selection of inhibits
- automatic threat prioritization in several levels, only displaying a certain number of threats of highest levels
- alphanumeric display of these threats, for good readability
- programmed "look-through" capability thus providing jammer compatibility
- can be commanded to search a very narrow region locking for one specific electromagnetic signature or can be directed to search all frequencies reporting all contacts or programmed to execute many combinations between these extreme conditions
- frequency scan limits and scan speed are selected from pre-programmed sets of instruction or are changed by the operator while the system is operating
- acceptance windows in parameters such as PRF,



pulse width, signal amplitude or bearing are expanded or contracted as desired - differently in each of several frequencies

## 2. Acousto-Optical Signal Analyzer

Real-time signal analysis using acousto-optical techniques is being presently designed into reconnaissance receivers. Although the method of spectrum analysis using Bragg techniques has been used in other applications for a long time, only recently it seems to be gaining recognition to compete technologically and pricewise in the complex field of EW signal processing. Improvements in the necessary components of the system, allied with a decreasing cost and superior techniques are the key factors responsible for the impulse that has occurred in acousto-optical processing.

Bragg diffraction is one of the more important forms of sound-light interaction [22]. The basic arrangement for implementing spectrum analysis based on this principle is shown in Fig. 11. The so called Bragg cell is represented by the glass box filled with a liquid medium and having at one extremity a piezoelectric transducer cut for a specific frequency band. When excited by electromagnetic energy the transducer makes the conversion to acoustic energy which takes the form of a traveling acoustic wave with a wavelength  $\lambda$ , thus creating regions of different indices of refraction in the liquid medium.

A plane wave of coherent light with a wavelength  $d$  is then inserted into the Bragg cell at an angle defined by  $\sin \theta = d/2L$ . This angle is calculated in such a way that the components of the light wave diffracted in the liquid medium (due to the various indices of refraction) remain in





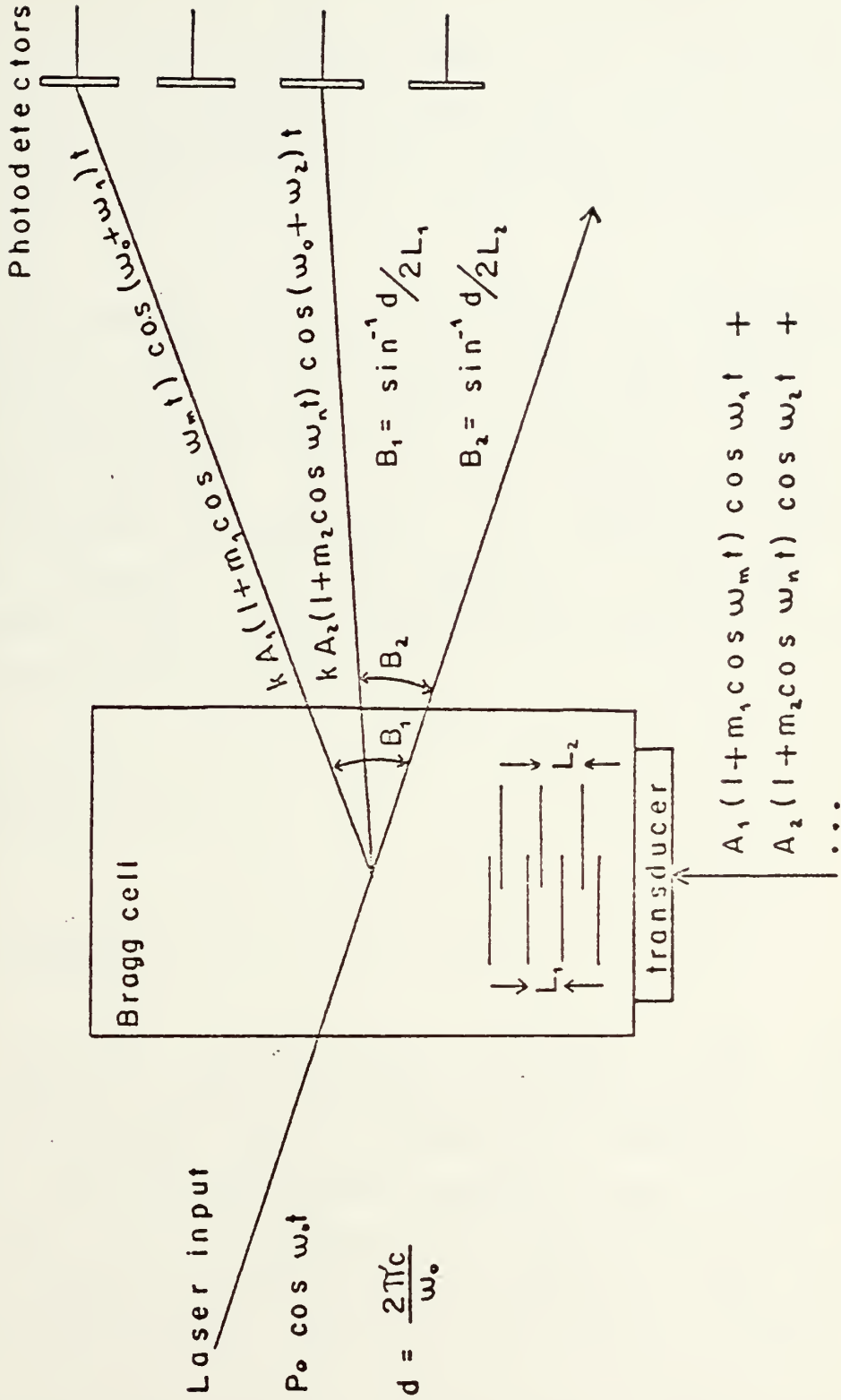

Figure 11 - BRAGG ACOUSTO-OPTICAL PROCESSING



phase, constructively interacting. As a net result, it can be shown that the light wave is deflected by an amount proportional to the frequency of the input electromagnetic energy to the transducer. Also, the amount of energy deflected is proportional to the amplitude of the signal input and therefore all data contained in the modulation is preserved.

If several signals at different frequencies are simultaneously applied to the cell, they are appropriately deflected and can be individually recovered by means of an array of multiple photodetectors. Therefore, in principle, the great advantage of this signal analysis technique is that it provides simultaneous and continuous processing without necessity of time sharing or scanning. Real limitations are not yet precisely known, due to the infancy of this application to EW.

#### D. MODERN SYSTEMS

##### 1. RHAW

Earlier surface-to-air missiles were normally command-guided through midcourse by pulses and thus airborne warning receivers were oriented to detect this type of signal. The 1973 Arab-Israeli conflict showed however the deployment of a continuous wave (CW) semi-actively guided doppler missile and therefore the existing pulse oriented receivers were unable to handle the low-power CW signals.

This fact led to a reevaluation of airborne warning receivers and has resulted in the necessary updating to face the CW threat [23]. Some modern RHAW systems are:



\* PCINTER, developed by General Instruments Corporation, USA, and recently selected to be used in the LAMPS helicopter Mk I ESM system. Pointer incorporates a high-speed programmable mini-processor outgrowth of the AN/ALR-42 Integration Receiver for the Prowler, US Navy EW aircraft. Pcinter uses four planar spiral antennas to provide pulse-by-pulse directional data (monopulse). Unlike other radar warning systems intended for self-protection, Pcinter provides fleet protection search capability for low pulse repetition rate, low scan rate acquisition radars rather than concerning itself with main beam tracking or terminal threats.

\* AN/APR-41(XE-2), manufactured by Dalmo Victor Company and designed for helicopters and light fixed-wing aircraft. The system is thus conceived for low level flight with less dense but rapidly changing environment being specially suitable for warning against low altitude weapons such as Russian missiles SA-3, SA-6 or the Gun Dish fire control radar. The system is based on the AN/AIR-46 experience however simpler because of decreased requirements. The composition of the APR-41 is as follows:

- DF Antenna/Receiver (4 units required)
- Guidance Antenna/Receiver
- Digital Processor
- Indicator Control

The frequency coverage of the DF receivers is from E through J bands in three sub-bands while the guidance receiver goes from 700-1400 Mhz.

\* AN/ALR-45, manufactured by Itek Corporation, USA and used aboard US navy's fighter and attack aircraft. The basic system is intended to cover pulse threats from 1-14.5 Ghz, with digital filtering but retaining analog logic. It employs a real-time display and is programmable in the field



with a screwdriver. A new version incorporates a modification kit that gives a CW detection capability and a C/D band direction finding capability. These bands are respectively the bands of the guidance systems for the Russian missiles SA-2 and SA-3. The programs that have resulted in this modification kit were known as Compass Sail and Compass Tie.

\* AN/AIF-46, the RHAW system most used aboard USAF aircraft, is in its basic configuration a 2-18 Ghz wide-open front end, crystal video, field programmable system, intended for a complete integration with other systems such as Power Management, Weapon System Handoff and Infrared Warning. The receiver, control unit and displays are made by Itek while the digital signal analyzer DSA-20 is made by Dalmo Victor. Recently this company announced the production of a new processor, the ALR-46A which provides faster operation, greater processing capacity, advanced memory organization and powerful new software algorithms. This version is a strong candidate for the F-16 aircraft sold recently to four NATO countries.

\* AN/AIR-56, developed by Loral Electronics and intended for use on the F-15 aircraft. It incorporates power management concepts for the efficient utilization of all EW suite. The same Company was recently awarded a contract for the EW suite of 85 Belgian Mirage aircraft. The system, called RAPPORT II (Rapid Alert Programmed Power Management of Radar Targets) includes a radar receiver and smart noise jammers, being the most advanced EW system to be exported from the United States. It is also a serious competitor for the F-16 NATO's aircraft [24].

Loral also has a simpler system known as MPR (Multi-Purpose Radar warning), in two versions, model 11 and 12. The basic system is a four-quadrant multi-channel crystal video receiver with a digital processor, the MFP-1





or its smaller version MPP-2, for light and rotary wing aircraft.

## 2. ESM - ELINT

These receivers, unlike the RHAW type, are not so heavily constrained by size, weight and primary power requirements. Also, they do not have the need for completely pre-programmed operation because common platforms for them admit the presence of dedicated operators. Another possible difference between the two categories is that the RHAW receiver is more concerned with specific threats such as emissions related to expected missiles in a tactical environment while an ELINT receiver is supposed to analyze also more general signals such as communication links or distant radars. In this last case, for instance, the lower band of the receiver must be able to keep track of VEF-UHF radars, such as the Russians Spoon Rest early warning radar (147-161 Mhz), the Flat Face (810-950 Mhz) and others. The upper limit of ELINT receivers, being presently kept at 40 Ghz implies therefore a total required coverage of about 8-9 octaves. These systems, in the same manner of RHAW receivers, may have a dedicated, specially built digital processor or they can share general purpose computers.

ELINT sometimes can also be applied in a different way. Normally, the analysis of a signal is made on the basis of the transmitted emission. However, similarly to a radar bistatic application, information can be obtained not directly from the transmitted signal but from its reflected echo. The ELINT position therefore obtains its data by reproducing and recording what is presented in the enemy's display. This mode of operation, known as "Erigand", requires additional features such as synchronization of the sweep rate with the hostile radar scan rate and



establishment of a zero reference procedure such that the receiver displays the same presentation of the enemy radar. The theory behind these procedures is the same described in the literature of the bistatic radar however is a much more difficult implementation because the radar is non-cooperative.

A sample of different types of ESM-ELINT receivers will be presented in this section, comprising an IFM system, a superheterodyne scanning receiver and a Brigand processor. Other systems will be left to illustrate Chapter VIII, concern the Surface Navy. A comprehensive list briefly describing Intercept Receivers being developed or produced in several American companies just appeared in a microwaves magazine [25].

\* AN/WLF-11 is a militarized shipboard IFM signal acquisition receiver manufactured by ARGOSystems Inc., USA, that can operate over any two octave bands from 0.5-18 GHz. It incorporates a narrowband YIG filter channel in parallel with the wideband channel thus combining the best features of IFM and TRF techniques. The TRF channel may be continuously swept at a rate from 0.1-50 Hz or tuned manually. This channel has a bandwidth of approximately 20 Mhz and gives an increased sensitivity of about 10 db. A cursor on the display indicates the frequency where the YIG filter is tuned with an accuracy of about 50 Mhz and resolution 20 Mhz. A digital Pulse Train Separator can deinterleave up to three pulse trains and an operator can measure PRF, pulse width and scan rate on these emitters simultaneously. An Angle Gate Unit isolates signals for further analysis including DF and recording.

The WLF-11 is capable of being employed as the primary intercept receiver in a variety of shipboard system configurations such as:



- capability to directly interface with currently installed receivers and DF systems
- addition of an upgraded broadband DF capability to give the WLR-11 stand-alone acquisition, analysis and DF capability
- the addition of digital processing and a computer for completely automatic emitter intercept, threat identification and DF.

Another IFM system from the same company, the AR-626, incorporates a recently developed Multiband Activity Display which provides simultaneous, wide-open IFM acquisition capability for up to six bands. Each of the bands is presented in the familiar PAN (frequency vs. amplitude) format. A companion unit provides the more typical polar frequency/amplitude display for any selected band allowing increased resolution and dynamic range for more detailed signal analysis and a unique presentation of chirp and frequency-hopping signals.

\* AS 440 Brigand Signal Processor, manufactured by ARGOSystems, interfaces directly with any onboard ESM receiver. Inputs to the processor are either at an IF frequency (typically 160 Mhz) or video. An omnidirectional antenna is often used but a high gain antenna can also be coupled for increased sensitivity along a particular corridor. A primary intercept receiver is tuned to the non-cooperative radar frequency and it is possible to use an auxiliary receiver tuned to another frequency such as IFF signals. The display can be centered at the radar transmitter or at the Brigand processor location. A PPI display is generated by locking to the PRF and scan rate of the radar. Because the Brigand platform and the radar are not co-located, a standard radar sawtooth sweep cannot be used. Instead the sweep must be modified as a function of both the range separating the two platforms and the



direction that the radar antenna is pointing at any instant. Therefore, if the position of the transmitter is known a continuous surveillance of the environment can be maintained. If the position is not known, it must be determined. This is done by using points of reference such as a coastline, an island or other prominent targets and by means of controls adjusting their presentation until it agrees with the correct one obtained by other means such as a chart.

\* WJ-940 [26] belongs to a series of intercept receivers developed by Watkins-Johnson, USA, which also includes the AN/WLR-14 reconnaissance receiver used by American submarines. The WJ-940 was designed considering cost-effective design trade-offs for users with low budget. In its most straightforward form, it is composed of one or two tuners, control and displays. The tuners are single-conversion, superheterodynes, and digitally controlled, permitting band scan, limit scan or manual modes of operation as well as a special dependent, dwell and intercept modes. A two-trace display shows signal activity over two full bands, over two sectors of the same band or over a sector and a dependent sub-sector of a band or over two completely independent sectors in two bands. In the dwell mode, which can be selected for either trace, the receiver dwells at the frequency of an operator-controlled frequency marker shown on the trace for a 30 millisecond portion of each scan. Video is gated to an output for time-base display or for analysis during this dwell time, which permits the operator to continue monitoring signal activity within the band or sector while he conducts a simplified form of time-base signal analysis at one frequency in the scan.

#### E. DIRECTION FINDERS





The direction of arrival (DOA) of a signal is normally determined by one of the following general techniques:

- phase or time difference between signals arriving at two or more antennas
- amplitude of response vs. orientation of the beam(s).

The first technique needs at least two special receiving channels, since a single channel cannot be used to make phase measurements. This method presents the great advantage that the measurement is theoretically accomplished on a pulse-to-pulse basis, therefore eliminating all interference information existent due to modulations on the train of pulses. The implementation of these multiple-channel or Instantaneous Direction Finding (IDF) systems is however more complex and expensive and more suitable for larger platforms or special applications.

The second technique, using a single-channel receiver, is therefore the most commonly used for conventional DOA measurements. Being a sequential processing it is subject to time-scintillation errors caused by variations in the amplitude of the received signals, either due to modulation of the train of pulses or fading concerned with propagation effects. These scintillation-errors reflect on the accuracy of the DOA measurement and methods for minimizing them are normally employed, such as normalization of the amplitude of each received pulse as compared with a reference. This reference is normally chosen to be the signal received at the omnidirectional antenna.

There are several ways of implementing the single-channel process. The simplest technique, and therefore most employed, is the rotating-directional-beam system [27]. Shiptorne DF systems have employed broadband



high speed mechanically rotating antennas (up to 350 rpm) and more recently static or electronically-scanned phase arrays. The problems with mechanically rotating antennas are reliability and processing time, especially in dense environments where very fast signal processing is mandatory. The problem of reliability is represented by a low MTBF (mean time between failures) of the high-speed-rotating components. Indeed, for a better probability of interception of signals also generated by rotating antennas, the scan rate of the DF system must be very high.

Static arrays providing 360° of azimuthal coverage have been employed recently. They can be described as a fixed antenna array fed by a computer-controlled high-speed switching matrix. The DF precision and resolution are a function of the type and number of antennas employed, requiring therefore a compromise with the size, cost and weight of the array. For a precision of about 3°, depending also on the frequency band, typically 8-12 elements should be employed for 360° coverage. Static arrays, although more complex, could overcome deficiencies of rotating antennas, with an additional advantage that the beam can be more easily started or stopped. Therefore, the DF system could be left inactive, only becoming operational when automatically requested by the analysis receiver.

In any case, whether mechanically or electronically rotated, the broadband coverage requires different types of antennas for the complete range up to 40 GHz. This is also true for the omnidirectional acquisition antenna and therefore the overall system has become a complex miscellaneous of diverse antenna configurations. Although an optimal arrangement is not patronized by all manufacturers it has been common to use broadband "frequency-independent" antennas such as log-periodic, cavity-backed, planar, conical or helix spirals for the lower and medium frequency



horns and scalar horns for the upper part of the spectrum.

Designers of RHAW systems, with restrictions in space, normally work in a more limited coverage such as 1-18 Ghz. They are pushing the development of broadband antennas, baluns and waveguides or trying to make the arrangement more compact, in order to expand lower and upper limits of their coverage. Problems inherent to aerodynamic requirements of the airborne platform as well as the conditions of operation complicate still more the configuration of the DF antenna, normally requiring a protective radome mounted beneath the belly of the aircraft or atop the fuselage.



## VI. THE MISSILE THREAT

### A. MISSILE WEAPONS

The countermeasures presented in the preceding chapters are quite general and antimissile warfare is just one of their applications. The sophistication of the modern missile and its increasing deployment on all kinds of platforms lead however to the development of tactics and techniques more specifically suitable to counter this threat. This is the case of the modern equipments that use the heat radiation as the detection factor. Although antimissile warfare is not the only application for these devices it is certainly one of the most important. For this reason it seems worthwhile to briefly discuss the missile threat just before the chapter that deals with electro-optical devices.

#### 1. Surface-to-Air Missile Weapons (SAM) [28]

The SAM belongs to a complex weapon system that normally have the following subsystems:

- acquisition radar
- target tracker
- computer
- missile launcher
- missile tracker
- command station.





The purpose of the first subsystem, the acquisition radar, is:

- to provide early warning
- to determine gross target position and velocity
- to determine target priority.

The function of early warning is not degraded by countermeasures because its existence is evidence of attack, but the other functions are seriously affected by them. Indeed the acquisition radar, as well as the target tracker, may be misled or disabled by any of the jamming techniques described in earlier chapters, increasing the reaction time of the system, especially if these radars have automatic detection and tracking circuits.

The target tracker, initially restricted to one target at a time, received a considerable impulse with the advent of phased-array radars, that allowed a single transmitter to illuminate many targets by sequentially jumping its agile beam from one target to the next. Improved signal processing techniques were also necessary because now the illumination would no longer be continuous and information must be extracted from stored sampled data.

The primary inputs to the computer are the target position information given by the target tracking radar and the missile position information given by the missile tracking radar. The computer outputs are often launcher pointing commands, launcher firing commands, missile guidance information and, in some cases, warhead detonating commands.

An alternative scheme to this weapon system configuration is to put some target homing capability into the missile. If done, the missile itself senses radiation from the target and steers toward it. This can be done in



three ways:

- semi-active homing
- active homing
- home-on-jam.

In the former, the radiation is that of the SAM tracking radar reflected from the target. In active homing, the missile contains both the transmitter and receiver. In home-on-jam, the radiation is from the target's jamming transmitter.

It is often possible to describe a SAM's flight in three distinct guidance phases:

- launch or initial course guidance
- midcourse guidance
- final or terminal guidance.

A SAM may be designed to use for its entire path only one type of guidance or it may be designed to use different guidance schemes along its trajectory. As a possible example a SAM may use in the first phase inertial guidance and, after booster separation, command guidance is used to steer the missile to within five miles of a target. Then, the terminal guidance phase could be accomplished by the missile's own active homing system.

Each type of guidance can have several variations, each one with its own vulnerability to countermeasures. The command guidance link, for example, may be a separate radio link with its own transmitter and receiver or the transmit steering commands to the missile may be encoded into the pulses of the target tracking radar. A third option is the beam-rider system in which the missile seeks the center of the target-tracking radar beam. This is the best situation for countermeasures protection since the missile receiver antenna is pointed toward the friendly ground transmitter



and away from the target jamming interference.

## 2. Surface-to-Surface Missile Weapons (SSM)

The most numerous and varied missile weapons belongs to the surface-to-surface class. Thus, there exists several ways to classify these missiles. On the basis of flight range, for instance, the SSMs are subdivided into short range, medium range and long range or intercontinental missiles. Another classification could be based on the intended use of the weapon: tactical or strategic missiles.

Although the same basic principles and types of guidance described for the SAM apply to the SSM [29], a typical guidance system of several anti-tank missiles, the wire control guidance, should be mentioned. Modern missiles use this method of control and it will be no surprise if this type of guidance finds application beyond the anti-tank role in a near future.

One version of the surface-to-surface missile is becoming at present one of the most concerned threats in a possible conflict: the cruise missile [3]. Indeed, recent years have seen the massive deployment of anti-ship cruise missiles aboard ships (and aircraft) of several nations especially from the Soviet block.

Cruise missiles are very difficult to detect in time for efficient reaction by the ship's defenses because they present small visual or radar cross sections and also because they are often sea-skimmers, flying at low altitudes. This results in multipath echoes due to reflections off the surface of the sea as well as clutter created by this surface. Multipath problems occur when the separation between the target and its image is less than the



resolving power of the radar. The use of special techniques such as off bore-sight tracking and double null tracking offer the best practical solution to these problems [30]. Even if detected, this low-altitude profile makes it difficult firing for conventional anti-aircraft artillery due to the extreme depression angles. To complicate the problem more, other cruise missiles, like the Russian Shaddock, employ high trajectories with steep ballistic descents on target and so ship's defense cannot concentrate just on sea-skimming missiles.

Cruise missiles can be employed in all kinds of ships ranging from the small and fast patrol boats to cruisers, giving thus to the small ships tremendous firepower. This also means that weak navies probably can afford the acquisition of a good number of these modern "dreadnoughts"...

On the other hand, large ships are excellent targets for detection by IR sensors and radars. This, associated with their limited maneuverability, makes them reasonably vulnerable targets, unless adequately protected by efficient countermeasures and antimissile weapons.

Surface-to-surface missiles launched beyond radar and visual distances can be directed by reconnaissance aircraft, submarines or data for the guidance could even be obtained through a satellite link.

### 3. Air-to-Surface Missile Weapons (ASM)

Air-to-surface missiles are intended for targets ordinarily destroyed by conventional aircraft, but which are strongly protected by anti-aircraft defense. Again, it is possible to subdivide into short range, medium and long





range or from the standpoint of deployment into tactical and strategic missiles. Similar to the surface-to-surface case, the anti-ship cruise missile fired from an aircraft is, at present, of great concern in a conventional conflict.

#### 4. Air-to-Air Missile Weapons (AAM)

The intended targets are piloted as well as pilotless aircraft like drones and missiles. It has been suggested that some tasks of the AAM could be performed by SAMs, thus leaving the aircraft with more versatility and availability for other uses of its pods. However, it must be considered as an important factor the maneuvering capability of the aircraft employed as a platform for the launching of missiles.

Common Soviet air-to-air missile firing tactics involve ripple firing of two missiles at the same target, at an interval of about one second. The first missile fired is an IR homing type and the second a radar guided type.

Another class of missiles known as anti-radiation missiles (ARM) should be mentioned. They are normally of the ASM or AAM type and their guidance is by homing on the enemy's electromagnetic radiation, especially radar. Therefore, the threat of their presence in an attacking force imposes on the enemy radar discipline or even silence and thus ARMs are very deterrent weapons. Ideally, however, these missiles need a supplementary type of guidance as a backup in the event of shutdown of the victim radar.

Appendix B presents a list of modern missiles according their primary function. The list is restricted to airborne and shipborne (excluding submarine) applications, covering methods of guidance, flight profile and other



characteristics of small and medium range missiles.



## VII. ELECTRO-OPTICAL ELECTRONIC WARFARE

### A. GENERAL

Electro-Optical Electronic Warfare (EOEW) is a new field that is expanding very rapidly. So, although at the present time it is only a small part of the vast complex of EW, the perspectives are that in a near future it will become very important and this is the reason why the subject deserves a separate chapter. EOEW, encompassing ultraviolet, visible and infrared techniques, is expected to have in the United States its monetary support at least tripled by the end of the decade, due to the wide proliferation of several devices working in that region of the spectra. Indeed, electro-optically guided armament, infrared warning receivers and lasers are spreading in the armed forces of all developed countries. This can be easily verified by comparing the number of IR products advertised in any of the specialized EW magazines from two years ago and now. The industry is working hard in new projects which are usually of a classified nature because, due to the infancy of the field, each new discovery is a very great advantage over the enemy. EOEW has yet hardly been tested on the battlefield and many surprises can arise if one is not ready for it. In principle, the threat is expected to be present specially in weapons aiming, spotting, tracking and guidance but also as efficient means of surveillance, detection, localization of the enemy, and in communications. The techniques employed encompass the use of sophisticated and powerful lasers, sensitive detectors, as well as non-reflective paints,



engine exhaust shields and IR flares.

To see an important point in the use of EOEW it is suitable to compare, in a crude way, a Radar Warning Receiver and an Infrared Receiver, both passive sensors. The first one will only detect the enemy if he cooperates, that is, emit radio waves by activating some of his equipments. On the other hand, there will always be infrared emission to be detected by the second one. The art of making this detection easy or more difficult is, in this situation, the scope of EOEW.

The detection can also be done by active means as with a radar laser and again several techniques are being developed such as anti-laser coatings and attenuation of the laser energy by the use of chemical additives in vehicle exhaust systems.

Another tactical application of infrared in countermeasures consists of employing an aircraft in a stand-off position illuminating the target, the scattered radiation being used in a semi-active manner to guide a smart-bomb launched from another position.

## E. CLASSIFICATION

It can be seen that despite some particularities of optical systems the techniques encountered in EOEW are similar to the ones that are employed in the microwave part of the spectrum.

In this sense, although a general classification of EOEW does not still exist, it seems reasonable to follow closely the one adopted for conventional EW.





## 1. Infrared Warning Receivers

The principal performance limitation of IR warning receivers has been high false alarm rate [31]. Not only on-purpose episodes created by the enemy but "natural" false alarms due to the severe background of the IR spectral region result in a high alarm rate. The search for adequate discriminating techniques to successfully cope with this problem has been, and remains, the challenge facing infrared systems designers.

This high false alarm rate reflects not only in the confidence of the operator but in the overall operation of systems where the launching of weapons is automatically activated by an alarm. Unchecked, this can represent depletion of the armament until a complete exhaustion renders the system inoperative when faced with the real threat.

If the background is bad in the air-to-air role, it is horrendous in the air-to-surface. In order to detect a SAM, an infrared warning receiver must look directly to the ground, where exist all kinds of sources capable of emitting IR radiation and so generate false alarms. The only way to solve this problem is by proper data processing. In order to do this, it can employ spatial, temporal and spectral methods of discrimination using respectively the distinguishing features of plume size, burn time and spectral energy distribution. The last discrimination, for instance, can be achieved by performing a spectral analysis of the several detected sources of radiation and correlating these with the known energy distribution of expected threats.



Correlation, as a method of discrimination, has the important advantage that it does not adversely affect detection probability like increasing the threshold by coating the infrared dome with black spray. It is important to keep in mind that sometimes the radiation strength from background sources exceeds that of the threat missile.

The AN/AAR-34 infrared warning receiver developed and manufactured by Cincinnati Electronics Corporation, USA, and in use on the F-111 was until recently the only one in the operational inventory. Several others are in the stages of research, development or testing, under sponsorship of the armed forces and soon will find their way to the inventory. The AN/AAR-34 is a scanning sensor, tail installed and is primarily designed to protect the high, fast planes from air-to-air threats.

A similar model is the AN/ALR-23. Both receivers locate enemy aircraft and detect missile launches by sensing their radiated energy. The set then generates a threat warning for the aircrew and automatically controls countermeasures to protect the aircraft.

An export version of this last equipment is the CMR-100. This signals the fact that the US government is beginning to consider a release of infrared warning receiver technology for allied countries.

Also developed by Cincinnati is the AN/AAR-38, a staring (non-scanning) sensor specially suited for helicopter use and more appropriate to be used in the surface-to-air protection role.

A variation of these devices is the Laser Homing and Warning System (LAHAWS) whose function is to alert a target that he is being "painted" by a laser beam. The system



classifies and localizes the source and then takes appropriate action to oppose this surveillance by the enemy.

The Navy deployed into the Mediterranean theater a Martin-Marietta optical collection and classification system called Cluster Hemlock which observes, records and classifies man-made signals from the visual through the infrared. It can intercept laser energy without being in the laser beam at ranges in excess of the optical horizon by detecting laser energy scattered by aerosols in the air. These off-axis techniques are very important in EOEW where the beams are generally very directive and so it is very difficult to position a sensor in the beam. The techniques are applicable not only against highly secure, covert optical communications but also laser radar paths [32].

Another optical device, the Infrared Laser Fanger (IBLR), is being developed by the Air Force Avionics Laboratory. This system is composed of a track-while-search IR tail warning receiver and a laser triggered by its output. The functions of the laser radar are first to confirm the presence of the threat and second enable a priority to be established in a multiple threat environment, based on information of range and closing rate.

## 2. Imagery Systems

Optical and infrared systems possessing imagery properties are gaining wider acceptance for a broad range of tactical applications. These systems not only detect airborne targets but they normally can give an image of the entire spectrum of tactically interesting ground targets. Imagery systems can be passives, semi-actives or actives:

- passive sensors use the natural radiation from the target



■ semi-active sensors use the reflected radiation from a source that is not an integral part of the sensor system

■ active sensors use reflected radiation from a source that is an integral part of the system.

Forward Looking Infrared (FLIR) is a system using passive sensor technology that can provide high-resolution imagery in real-time [33]. FLIR operates in the longer wavelength portion of the infrared, sensing the radiation emitted by targets by means of background-limited photodetectors.

Low Light Level Television (LLTV or L<sup>3</sup>TV) is a semi-active system specially useful under night-time conditions and therefore the source of illumination can be moonlight, starlight or airglow. These illuminations are about 10 orders of magnitude smaller than the one provided by the sun at noon on a clear day.

The L<sup>3</sup>TV concept is employed in the TISEC (Target Identification System, Electro-Optical) now in production by Northrop, USA, for the F-4E aircraft: a pair of vidicon cameras, housed in the left wing, will provide a magnified TV scene at the copilot's seat. The same imagery concept has been used in the Pave Spike, a laser designator for the USAF, manufactured by Westinghouse.

### 3. Denial-Jamming Lasers

The following applications of optics can be considered the equivalent of the conventional microwaves denial jamming, where the objective is to nullify the detector capability of the enemy. As a possible example of these techniques, it has been said that the Navy in concert





with the Air Force is developing a pod mounted laser visual countermeasures system for combatting hostile, optically aimed or optically guided weapons. The pod would employ a blue-green laser to search for any optical system viewing the platform and detect it from backscatter returned from the viewing optics. A laser would then saturate or even burn the hostile optics with laser energy. This can be done also with serious consequences against a satellite link possibly used by the enemy.

This type of countermeasures can also be applied against the human naked or telescopically aided eye, sometimes used as the target detector for aiming weapons. For this purpose, some lasers are being developed that would generate high power pulse outputs at 0.53 microns, in the heart of the visible green region, to which the eye is most sensitive. Pulses from this frequency doubled 1.06 micron yttrium aluminum garnet (YAG) laser could injure or destroy the retinas of the eyes of those directing weapon fire against the aircraft or would otherwise penetrate the optical train of the aiming mechanism and tracking gates.

There are however problems with these laser transmitters. First, the difficulty of locating the hostile laser equipment and the problem of aiming the narrow beam of an airborne laser jammer from a high speed aircraft. Second, the modern aircraft is already pod saturated and pilots are reluctant to sacrifice a valuable pylon position on attack aircraft for still another countermeasures pod. Other platforms do not suffer from the same problems and it is easier to implement these systems.

The Kuras-Alterman's POSITAR (Passive Optical Spectrometric Identification Tracking and Ranging) was originally conceived as a tank antimissile system but a design has been also configured for shipboard use. The



sensor is a wide angle IR scanner with two infrared detector processor channels that respectively search for and examine point sources of high amplitude IR radiation. If the incoming spectral signatures match the stored spectra characteristic of targets of interest such as rocket motors or engines spectra, the target is accepted and the targets's azimuth and elevation position is encoded. An off-the-shelf laser is then accurately directed to the spectrometrically identified hydrocarbon motor determining its range. In addition, the laser can emit a high intensity 1.06 or 0.53 micron laser pulse for sensor degradation. POSITAR is then an IRLR device and/or an optical sensor jammer.

Being a modern type of equipment with a different technology, it is worthwhile to look at some of its specifications [34]:

\* SEARCH

▪ 40° EL x 3390° AZ	0.025 sec
▪ 800° EL x 3390° AZ (Surveillance Zone)	0.5 sec
▪ Scan Rate	40 rps
▪ Field of View	2 mrad EL, 0.5 mrad AZ

\* TRANSMITTER

▪ Repetition Rate	24 pps
▪ Peak Power	10 Mw
▪ Pulse Width	20 nsec

#### 4. Deception-Jamming Lasers

Substantial progress is being made in the development of short wavelength infrared jammers. All military services are in varying stages of introducing on a limited basis pod-mounted airborne deceptive systems for countering infrared heat seeking weapons. Indeed it is expected that this type of countermeasures (IRCM) will



receive, and not lasers, the bulk of production expenditures over the next five years.

The basic idea is the radiation of large pulses of infrared energy behind the aircraft. Infrared homing missiles locked onto energy emitted by an aircraft's engines will then mistake the deliberately generated pulses for engine signals and will be deceived into breaking lock in a vain effort to follow the deceptive pulses. How can these pulses be confused with the DC emission of the engines and the lock be broken?

In normal operation the energy emitted by the engines is chopped by a reticle and then filtered to eliminate undesired components. The resultant carrier frequency feeds the precession coils of a gyro and then by an error controlled feedback loop maintains the seeker head correctly aligned. When the seeker is locked onto the target, the error angle is small, the offset angle is about zero and the target appears at the center of the reticle. The deceiving pulses, which may be large compared to the engine signal, arrive in some timed sequence and appear off the missile axis and at some significant non-zero offset angle. The gyro then precesses erroneously trying to bring these strong deceptive pulses to the center of the reticle, breaking the lock. Once lock is broken, the missile probably will not reacquire the target.

Some modern examples of these deception jammers are:

\* AN/AIC-123, developed by Electro Optical Systems, Xerox Corporation, now operational in US Navy inventory and employed in carrier-based tactical aircraft, like in the F-4 Phantom. It is also being manufactured, under license, by British Aircraft Corporation for NATO countries. The system uses pulsed cesium vapor lamps in a single, low duty cycle



rate, high-energy pulse.

\* ALQ-132, Sanders Associates' "Hot Brick", that utilizes fuel burned in a combustion chamber to heat a membrane that radiates the desired spectral energy modulated by rotating shutters, with high duty rate pulses. Potential applications includes the Marine Corps Rockwell OV-10, USAF close support Fairchild A-10 and Lockheed C-130 transport aircraft.

Sanders also build the ALQ-144 model used on US Army helicopters, Boeing CH-47, Bell UH-1 and OH-58. For the fixed wing Grumman OV-10 Mohawk they have the ALQ-147 which is mounted aft of a fuel pod. This system uses a mixture of fuel and air to generate infrared energy.

Concluding, much more could be said about the research that is being done in EOEW. The discussion above was restricted to systems that are in production or close to a possible use.





## VIII. SHIPBOARD ELECTRONIC WARFARE SYSTEMS

In the previous chapters Electronic Warfare was covered independent of the carrying platform: ground-based, surface ships, submarines, fixed-wing aircraft, helicopter or even drones.

It is necessary that military personnel of all services be familiar with all of them, because the threat could be originated from any kind of vehicle. However, since some navies do not possess large defensive air arms, it is probably worthwhile to concentrate in one chapter some topics concerning the area of most importance to these navies, namely the Surface Navy.

Almost all articles that can be found in the open literature as well as descriptive advertisements about EW are concerned with the airborne use. The limitations of size, weight and aerodynamics of these platforms are a constant challenge to the development of new techniques or improvement of the present ones. In some cases, due to the lack of available operators, automation must be total and high reliability and fast response are required.

On the other hand, shipborne equipments seem to have a more stable evolution. Besides this, the Surface Navy has been slow in recognizing and accepting the value of EW in contrast to the Naval Air Service and Air Force.

The major modern day threats to ships are the air-to-surface and surface-to-surface missiles, as was seen in chapter VI. Faced by this growing threat, the Navy has



been seeking the optimal solution to the defense problem that in principle should be composed of a mix of hard weapons, electronic warfare techniques and suitable tactics.

If the problem of finding a solution to an optimal defense were only a matter of limiting space for armament and EW equipments, it could be very close to being surmounted because of the reduction in size of the modern computer, one of the largest components in many systems.

However, neutral observers also believe that Navy's reluctance to buy shipborne EW equipment is because there are still doubts about the guidance system and other characteristics of certain Soviet missiles and consequently it is not in the interest of the service to invest heavily in expensive and complex EW systems that are not sure to correctly counter the possible threats [3]. Hard kill techniques, however, are almost certainly a confident investment, less susceptible to being later judged as the wrong equipment.

Until a few years ago most of the American and allied nations ship's electromagnetic defenses were basically centered on the AN/WLR-1 receiver. This is not a very modern countermeasures receiving set by today's standards. The basic system has a frequency range from 50 Mhz to only 10.75 Ghz covered in nine tuners, each consisting of a preselection unit, a local oscillator that used a Reflex Klystron and an IF preamplifier. The time for mechanically scanning one band is as much as 90 seconds and thus the system is almost useless as a detection and location device for supersonic missiles [35].

GTE Sylvania's WLR-8 was designed to update the WLR-1 equipment. The new system has a digitally-controlled spectrum scan and analysis receiver covering the 50 Mhz to



18 Ghz frequency range with several automatic features provided by a mini-computer.

More recently there has been some development of several programs designed to improve the EW shipborne capability. For example, DPEWS (Design-to-Price Electronic Warfare System) is a program intended for ships the size of a normal destroyer and smaller. In this application the EW package is designed to provide only certain basic functions such as threat warning capability, wide area electronic surveillance and confusion ECM, rather than to be a general purpose system. The US Navy is currently undergoing parallel sea trials on two DPEWS equipments, one developed by Hughes and the other by Raytheon.

The Navy's new large destroyers, the 7500 ton Spruance class (DD-963) will also not carry any active ECM because of unfavorable trade-offs regarding cost and military objective. Their passive warning equipment probably will include a scanning receiver type WLR-1 combined with an IFM receiver like the WLR-11. It is interesting to point out that, when conceived, the Spruance class was scheduled to have active countermeasures. However the intended system, the SHORTSTOP, and even a diminated version of it, became too large and expensive for the ship. Still another packaged-system was tried, composed of the WLR-8 and the SLQ-17, a deception repeater jammer. This package is reserved nowadays for ships larger than a destroyer.

Also should be mentioned here the deployment of the destroyer-based LAMPS helicopter. LAMPS (Light Airborne Multi-Purpose System) provides an over-the-horizon detection and early warning capability especially when ships are operating under the Quiet Force concepts of radiation emission control, in addition to its ASW and long range missile targeting missions. The first operational



SH-2D/LAMPS were embarked on the guided missile cruisers class "Belknap".

The CGN-38 (ex DIGN-38) series naval ship also was designed to be, like the DD-963, a very imposing electronic platform. This class is a nuclear-powered, guided missile, fleet escort ship designed to provide defense protection against enemy submarines, air defense and a limited anti-surface ship defense capability. When initially conceived its EW package was composed of [36]:

- SLA-15 ECM set
- SIQ-12A ECM jamming set
- SIQ-17 ECM jamming, receiving and threat processing
- SIQ-19 ECM threat processing system
- SIQ-21 Threat processor
- SIR-14 ECM receiving system
- SIQ-28 Integrated EW Defense System
- UIQ-6C ECM jamming system

Now, just before the first ship of the class -Virginia- is to be commissioned, this complex suite probably has also been altered. Some new ideas include chaff-rocket launchers and the LAMPS.

Chaff rockets, as already mentioned in chapter II, are beginning to be considered also very effective for shipborne use. Besides the "Virginia" class, they are scheduled to be installed in the CGN-35 Truxton, the destroyers of the "Spruance" class and the new helicopter-carriers.

Other shipboard equipments of recent vintage are:

\* AN/SIQ-30 Threat Reactive Update Modernization Program (TRUMP), developed by the Kuras-Alterman Corp., USA. The system, that modifies the ULQ-6 deception repeater,





provides automatic signal identification, automatic tracking antenna and automatic signal processing. The program is aimed at giving a warning and threat reactive capability to destroyer escorts and smaller ships already equipped with the ULQ-6. TEUMP uses the SLR-12 receiver.

\* AN/SLR-20, a detection, location, identification and classification system developed by Amecom, USA, for the NATO hydrofoil.

Great Britain, as the United States, has seen a proliferation of EW systems in their ships, especially the new Type 42 Guided Missile Destroyer and the Type 21 Frigate. The cruise missile threat has also been of major concern to the Royal Navy and the optimal defense again will probably be a mixture of hard kill techniques, countermeasures and tactics.

The EW suite of the Type 42 also comprises a helicopter, the Westland/Aerospaciale WG-13 Lynx, equipped with a frequency agile lightweight I-band radar. The NTDS equivalent is the ADAWS (Action Data Automation Weapons System).

The third Royal Naval Equipment Exhibition shown in September of 1975 delineated the state-of-art of the British industry in EW [37]:

Decca Radar presented their RDL series of ESM equipments, exported to more than 14 navies around the world. The suite is modular in design, easily expandable and therefore several models are available. Decca's approach utilizes a crystal video detection technique. There are, however, IFM and superheterodyned versions of the system.

The basic equipment, the RDL-1BC for Fast Patrol Boats ,



provides instantaneous bearing, automatic pulse analysis and alarm, together with measurement of frequency band. For larger ships, the RDL-2ABC provides in addition frequency measurement, visual pulse analysis and RF amplification in the analysis channel.

The MEL Equipment Co. Ltd. promoted their SUSIE series shipboard warning receivers. There are three models of this system, intended for small ships (model 1), medium sized ships (model 2) and larger warships (model 3).

A brief description of SUSIE 1 follows: an all solid-state IFM receiver with frequency coverage 2-18 Ghz, capable of displaying instantaneously all signals received by its static antenna. It also features instantaneous presentation on alpha numeric display of pulse width, bearing, frequency band, pulse repetition interval and signal level of operator selected signal. Automatic warning, signal blanking and automatic tracking facilities are also available.

The MEL Company also has an active jamming system dubbed "Scimitar". It covers the 8-16 Ghz band and the power output is given as 600 watts CW and two kilowatts pulse. Operating modes possibly include CW noise, programmed band noise, wideband noise, RGFO, scan rate modulations, swept scan rate modulation and inverse scan gain.

MEL also exhibited "Protean", a lightweight chaff grenade-launcher under development for use on Fast Patrol Boats. Each launcher contains a total of 144 .40 mm grenades which are fired off in groups of nine producing a 300 square meters chaff cloud within five seconds of firing at a height of approximately 50 m.

Vickers Ltd. presented their 3-barrel "Corvus" chaff



rocket launcher in wide-scale service with the Royal Navy and now purchased by the French Navy. the Corvus was held under a security blanket for many years and performance details still are classified.

France also presented some of their state-of-art EW equipments in the 1974 French Naval Exhibition [38].

Thomson-CSF displayed their countermeasures suite for shipboard use. Basically it incorporates the DR 3012 search receiver, the "Arial" signal analyser and the "Alligator" jammer. The DR 3012 executes a passive search in all directions, within E through I frequency bands, detecting pulsed and CW signals and displaying their main characteristics, azimuth in particular. The Arial complements the receiver providing alarm, analysis and identification functions. The analysis include frequency band, pulse repetition frequency, pulse width, RF level, antenna rotation period. The identification is made automatically by comparison with a library including 15 radars. If unidentifiable, the parameters of the signal are displayed. The Arial can just display and record magnetically the informations or, in addition, drive an active jammer. The complete system is suitable for installation on any type of surface vessel and has been adopted by the navies of more than 20 countries.

The French Navy, as the British, also uses the Lynx helicopter and the Corvus 3 chaff rocket launcher as part of their electronic defense. The shipborne tactical data processing system, equivalent to the NTDS, is the SENIT, with several models. SENIT 5 is the newest one, for ships between 800 and 3000 tons. The system, with its 64 K computer memory, can process and visualize 40 tracks simultaneously and can centralize information on the state of readiness of the weapons and also designate targets to



the weapons.

France, as well as the other countries, seems however to give more importance to airborne countermeasures. As an example, last year's Le Bourget Air Show, in Paris, the largest military equipment show in the world, had an impressive stand of EW systems suitable for the Mirage and other aircraft. It is interesting to note that France, behind the United States and Russia, is third in volume of military exports.

Therefore, from the above description based on unclassified reports and Naval Equipment Exhibitions, some points can be observed, concerning the Surface Navy:

- \* rockets dispensing expendable cartridges such as chaff, IR flares and miniature transmitters are being more and more deployed on several ships. The intended use is for self-protection screening against the serious threat brought by the cruise missile.

- \* modular EW suites, often with emphasis in design-to-price characteristics, have been intensively procured for initial equipment or upgrading of EW systems of several vessels. Such is the case of the following EW equipments: Decca's RDL series, MEL's Susie with its three basic models, the French Arial and the American DPEWS, also in its three basic configurations. The modular approach allows small platforms to have only basic features such as given for instance by a pure CVR or IFM system. Larger platforms use more advanced series models, joining other analysis systems, and sometimes being integrated with active ECM. Powerful jamming systems are mostly used in ships the size above larger destroyers. Cruisers and nuclear powered vessels, of course, have complex EW suites, integrated with a tactical computer.





\* EW systems deployed in helicopters such as the American LAMPS and the French/British Lynx are being consistently used for EW fleet protection.

\* Communications and Radar Systems employing sophisticated technology are being shipborne installed. These systems, besides improved performance in the handling of desired signals, have in addition better anti-jamming capability. The new techniques, as already mentioned in preceding chapters, include spread spectrum, frequency hopping, PRF staggering, pulse compression, monopulse tracking, and others. The phased-array concept is also becoming a real-world feature, although yet limited to more special applications, due to its present high cost. As an example of these special applications it can be mentioned the SPY-1 radar, part of the AEGIS, the advanced air defense electronics system for the proposed American strike cruisers.

\* ECEW, although not yet heavily part of the inventory of the navies, probably will have important functions in a near future due to the wide proliferation of IR seeking missiles.

Nevertheless, at the present time, due to the specific characteristics of expected scenarios for future conflicts, the aircraft is yet the platform that receives the great part of the EW effort.



## APPENDIX A

### PRF AND PULSE WIDTH MEASURING CIRCUIT

#### A. NATURE OF THE PROBLEM

The circuit presented below is intended to be helpful in the measurement of some identifying characteristics of radar signals, such as the pulse repetition frequency (PRF) and pulse width (PW). In its development, emphasis was placed on the matching of the measuring process with the illumination period, that is, the period of time in which there are bursts of radar energy arriving at the Intercept Receiver.

Conventional pulsed radar signals were assumed during the experiment. As was pointed out in Chapter V, pulsed radars still represent a great percentage of real-world radars. The AN/SPS-10 for example, a conventional surface search radar, during a survey carried out in 1973, was reported as the most used radar in the US fleet, with more than 360 units installed, besides being widely used in other navies. Some modern systems use modulations in the PRF or PW and in these situations digital processors with complex hardware and software should be used for analysis.

In order to illustrate this description, representative parameter values for specific radars will be given, as well as the limits for these parameters will be established.



\* PRF - A reasonable range of values for conventional search, tracking or navigation radars is from 400 to 4000 pps. With a single PRF larger than this limit, the maximum unambiguous range becomes too small. With lower PRF the tendency is to have a small number of echoes superimposed, representing poor integration. In this case, the radar system does not have a very good improvement factor in the signal/noise ratio required for a certain probability of detection. A PRF of 650 pps is typical of the SPS-10.

\* PW - values between 0.1 and 60 microseconds are commonly found. Pulse compression techniques, especially chirp radars, are in widespread use and therefore pulses can be longer without losing discrimination in range. Systems that do not use these techniques should maintain a compromise between short pulses, leading to an improved range resolution and long pulses, allowing great energy and consequent increased range of detection. The SPS-10 has a choice between two pulse widths, 0.3 or 1.3 microseconds.

\* rotational rate of the antenna - Typical numbers for track-while-scan mode are 5 to 20 rpm. With faster rotation the trade-off is again a poor integration and its attending consequences. With slower rotation, fast targets could not be properly followed. A value of 6 rpm is representative of a conventional radar operating at a long-range-search mode.

\* beamwidth of the main lobe - Once more the value of this parameter is determined by trade-offs in the characteristics of the system. Small beamwidths are advantageous for an improved angular resolution as well as for a better immunity to jamming. Larger beamwidths imply in more echo pulses received and better integration possibilities. A beamwidth value of  $12^\circ$  was assumed during the experiment.

In order to have more data to work with, leading to a



better performance, it is necessary for the Intercept Receiver that the radar being analyzed emit in its direction during a considerable amount of time. Fortunately, this is also the goal of the radar: to receive the maximum possible number of echoes. Indeed, the number of pulses received by the omnidirectional antenna of the Intercept Receiver is approximately the same number of echo pulses received at the radar.

Based on the average data given above, it was possible to calculate the illumination period or time of permanence on target of the radar antenna beam. This value, given by

$$\text{Illumination period} = \frac{\text{Antenna Beamwidth (degrees)}}{6 \times \text{Antenna Scan Rate (rpm)}} \text{ sec}$$

was therefore found to be 0.33 sec.

If the illumination period happened to be longer, it could be possible to count the number of pulses that occur during a gate of one second. This number directly should represent the PRF. However, even by picking favorable parameter conditions, a maximum value of 0.33 seconds was found. Therefore, for these situations, the least significant digit was lost when trying to measure the PRF by the process of counting pulses within a gate. The precision of the least significant digit, however, is not very important because the goal was to identify the radar, and this was not affected by this loss. In more adverse situations, that is, when the illumination period was less than 0.1 seconds, two digits were lost. When this happened, however, it was because the PRF was longer than 1000 pps and therefore the two most significant digits were still present, allowing a reasonable identification. This consideration is based on the fact that the radar had its parameters adjusted in order to receive at least 10 echoes from a single target, for an acceptable presentation.





In other words, if the illumination period is short due to a narrow beamwidth of the main lobe or to a fast rotational rate of the radar antenna, the PRF is normally increased to keep a high integration of the received echoes.

At this point, it should be mentioned that another approach is to measure the Period Repetition Interval (PRI). This can be done by measuring the time interval between two successive leading (or trailing) edges of received pulses. This process, however, normally requires an iterative comparison between measurements, due to irregularities in the shape and timing of the received pulses. Also, since radars are more commonly specified by their PRF, more circuitry is required to invert the PRI value found. This approach is more easily implemented in digital processors.

## B. MEASUREMENT OF THE PRF

### 1. Basic Counter Theory

If a precisely known time period is established, an unknown frequency can be measured by totalizing the number of pulses occurring during this time-gate and by applying an appropriate conversion factor to obtain the desired parameter unit, such as pulses per second, megahertz, etc... This time period was provided by a free-running oscillator and decade dividers. A block diagram for this configuration is shown in Fig. 12 while Fig. 13 presents typical Decade Counting Assemblies.

Although for the PRF measurement only the three last outputs of the Decade Dividers (10 msec, 100 msec and 1 sec)



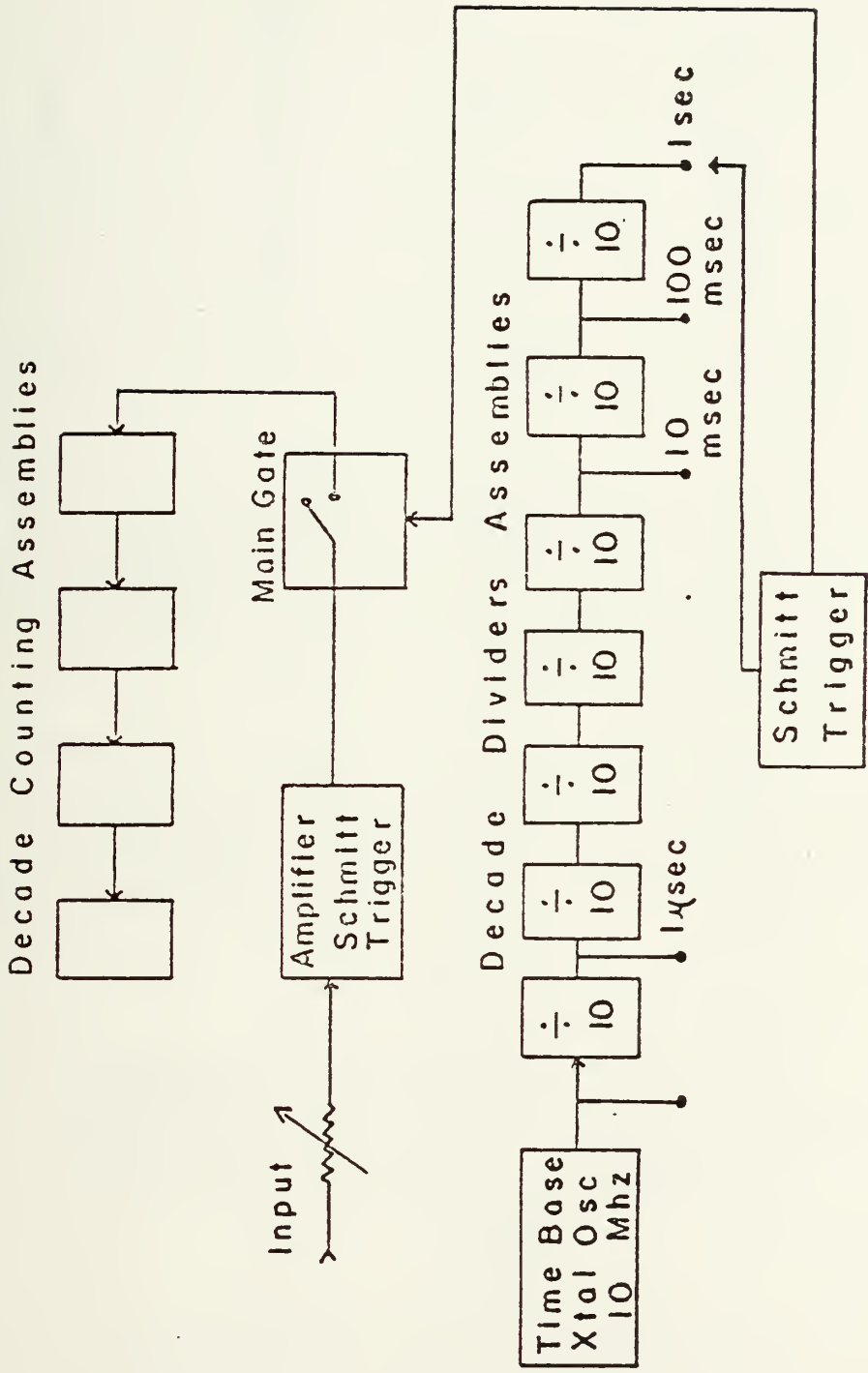

Figure 12 - PRF - BASIC CIRCUIT



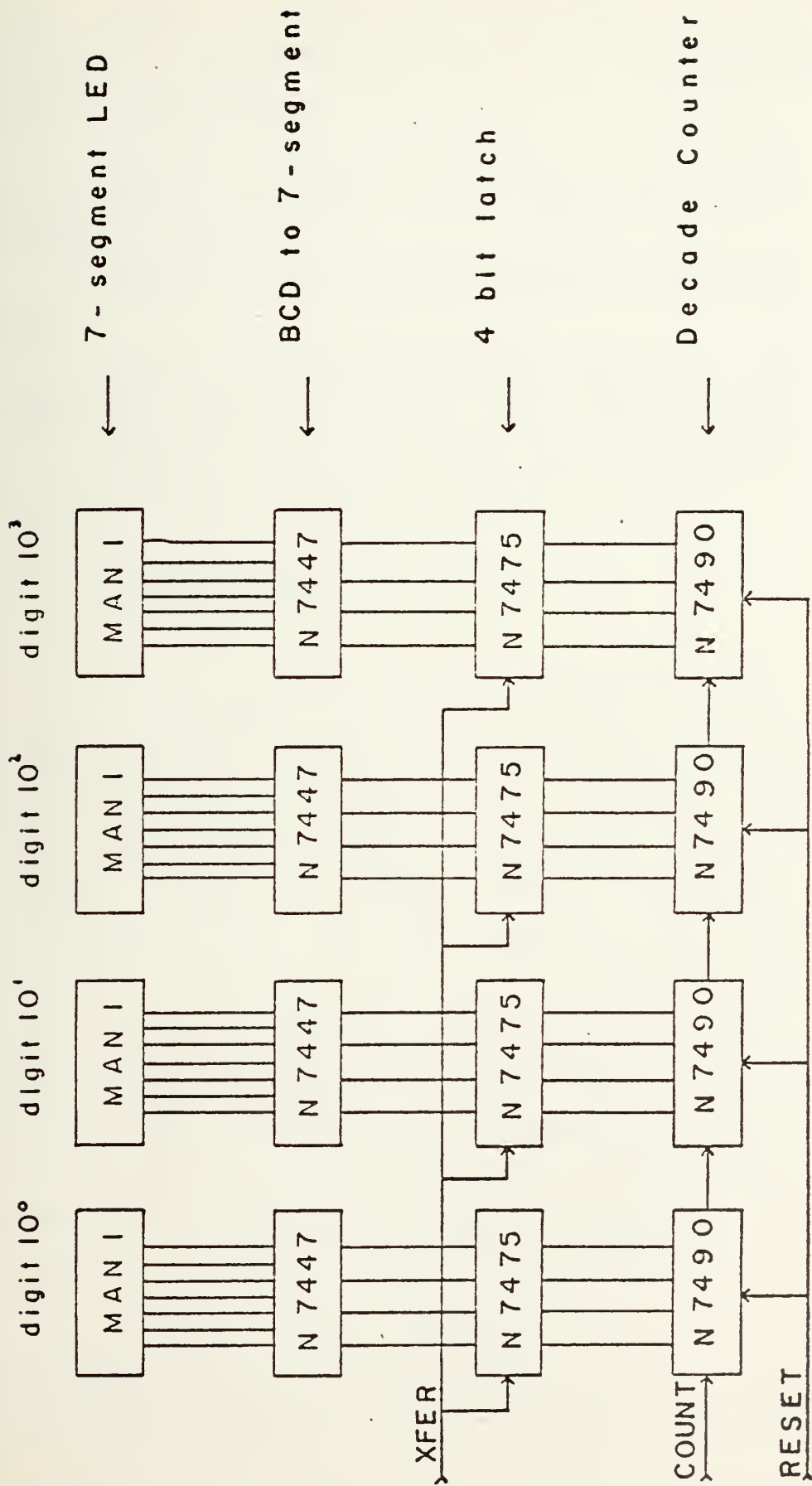

Figure 13 - DECADE COUNTING ASSEMBLIES



were useful, a 10 Mhz crystal was employed so that the same oscillator circuit could be used for PW measurements, as will be seen later.

With reference to Fig. 13, the following descriptions apply:

\* CCUNT - count input to decade counters from the main gate

\* XFER - transfer pulse which transfers the count in the decade counters into the 4 Bit Latches (memory)

\* RESET - reset pulse which resets the decade counters to zero prior to start of new count period.

## 2. Critical Part

When applied to the PRF measurement, the basic counter theory must take into account the fact that the radar antenna could be rotating. Therefore, different from normal frequency counters, a continuous train of pulses did not exist, and instead only happened during the illumination period. Means for synchronizing the opening of the measurement gate with the arrival of the train of pulses were tried. This was however a very critical point because when only a few pulses are received, loss of even one pulse could represent a prohibitive error in this PRF measurement. Of critical importance is the loss of the synchronizing pulse. Also, the triggered oscillator was harder to adapt to the PW measuring circuit. For these reasons, it seemed worthwhile to try another method, leaving the time-base oscillator operating in a free-running mode.

In this type of approach, it can be seen that, depending on the random arrival of the train of pulses, a gate could possibly not count correctly, this happening when





it is not completely filled with pulses. However, by logic control, it was possible to ensure that only correct values stay displayed. The way this was done is suggested by the logic circuitry shown in Fig. 14 and the corresponding waveforms and timing are presented in Fig. 15. The illumination-period waveform was indeed a simulation of the envelope of the train of pulses received.

Figure 15 depicts the more unfavorable situation where the relative position of the illumination period is such that it begins a short time after a main gate. In this case, in order to have a gate count correctly, a minimum illumination period of three times the duration of the main gate was required. Or conversely, the main gate must be at most one-third of the illumination period.

It could be observed that the first transfer pulse sent to the LEDs an erroneous reading but, immediately following, there was at least one transfer pulse that carried the correct reading. This last value stay displayed until the arrival of the next train of pulses, about 10 seconds later. It is important to observe that, for other situations, if a subsequent last gate was again just partially filled, its erroneous counting was not transferred. This was because there did not exist a corresponding transfer pulse for this gate. Indeed, as seen in Fig. 14, transfer pulses were obtained by a logic combination in an AND gate of the "transfer enable" and the illumination period that had already finished. About the temporary erroneous reading, it was practically imperceptible and, in addition, it only occurred on certain unfavorable conditions, therefore not being of any concern.



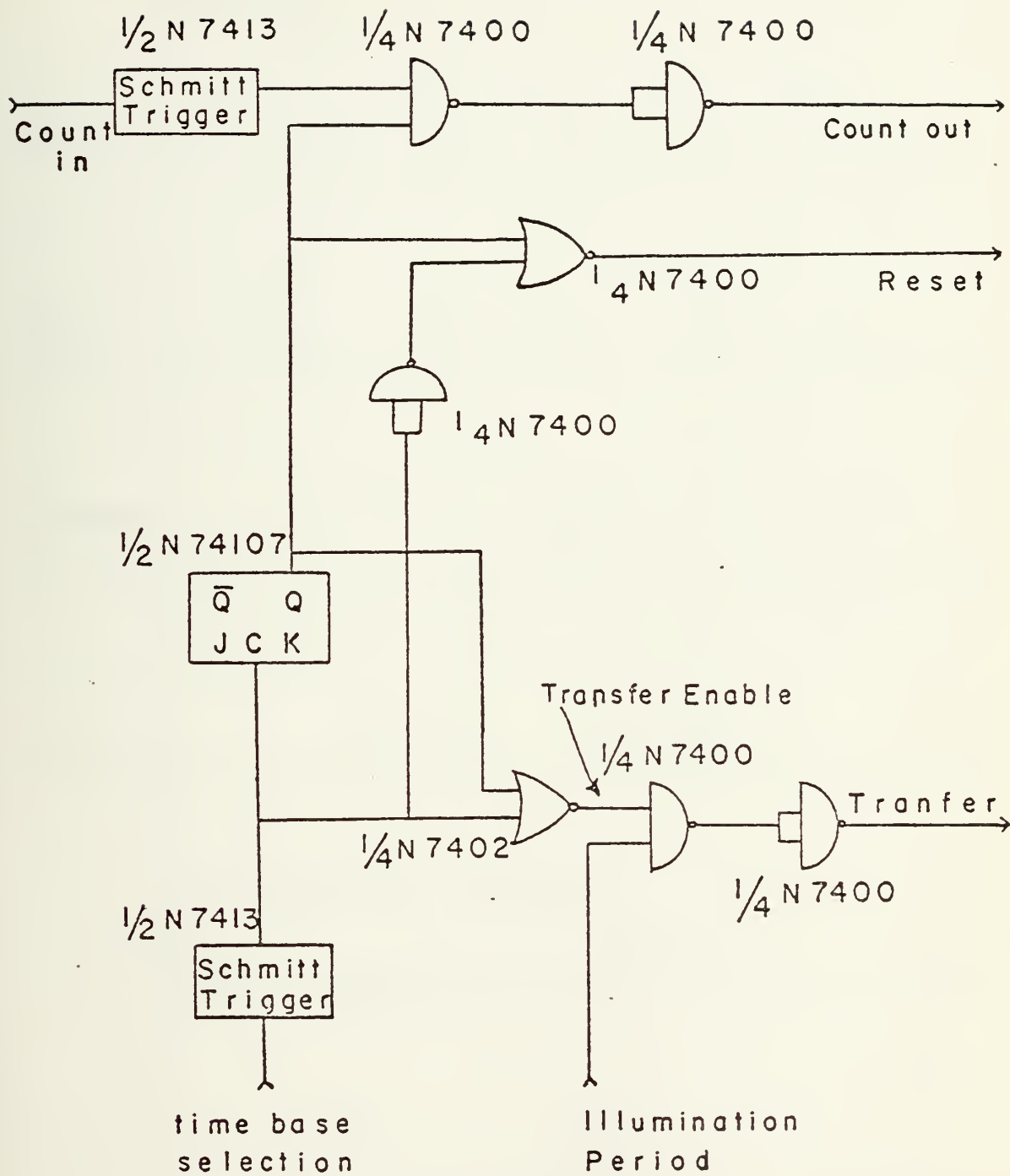

Figure 14 - PRF - LOGIC CONTROL



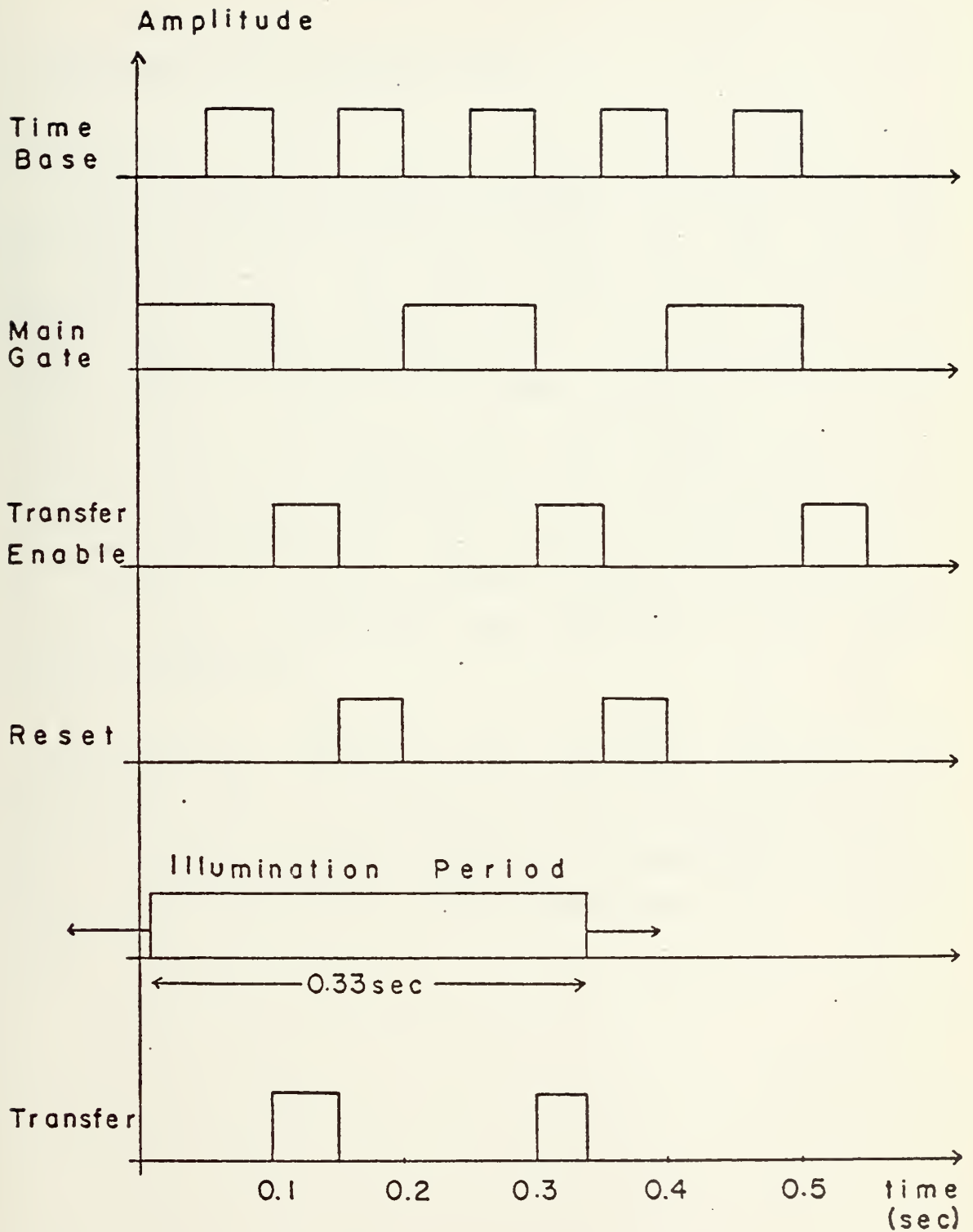

Figure 15.- PRF - TIMING WAVEFORMS



### C. MEASUREMENT OF THE PULSE WIDTH

A time interval meter has basically the same idea as the frequency counter presented previously, with the exception that the roles of the input signal and time base are switched. This means that, looking back at Fig. 12, inputs to the main gate are exchanged. Therefore, in the time interval meter, a selected time base is gated to the decade counters for a period of time determined by the input signal. In the PW measurement, the leading edge of a received pulse opened the main gate and the trailing edge of the same pulse closed it. For the case of larger PWs, as it was desired to have the display directly in microseconds, the tap of one microsecond was selected at the decade dividers assemblies.

It should be noticed that, different from the PRF measurement case, the train of pulses that was counted was continuous and no special provisions for synchronism must be made. Figures 16 and 17 respectively present the circuitry and waveforms generated for the measurement of the pulse width.





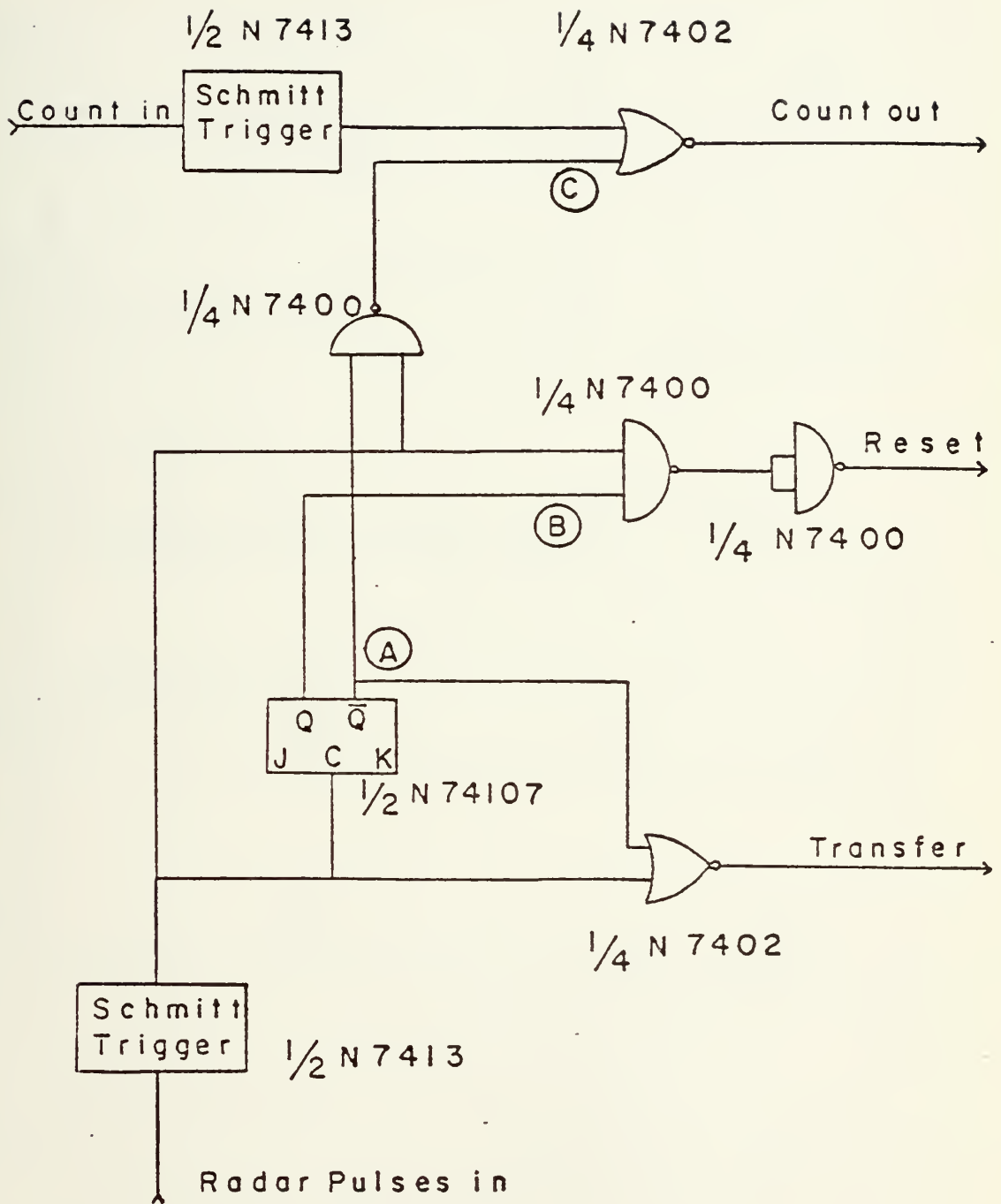
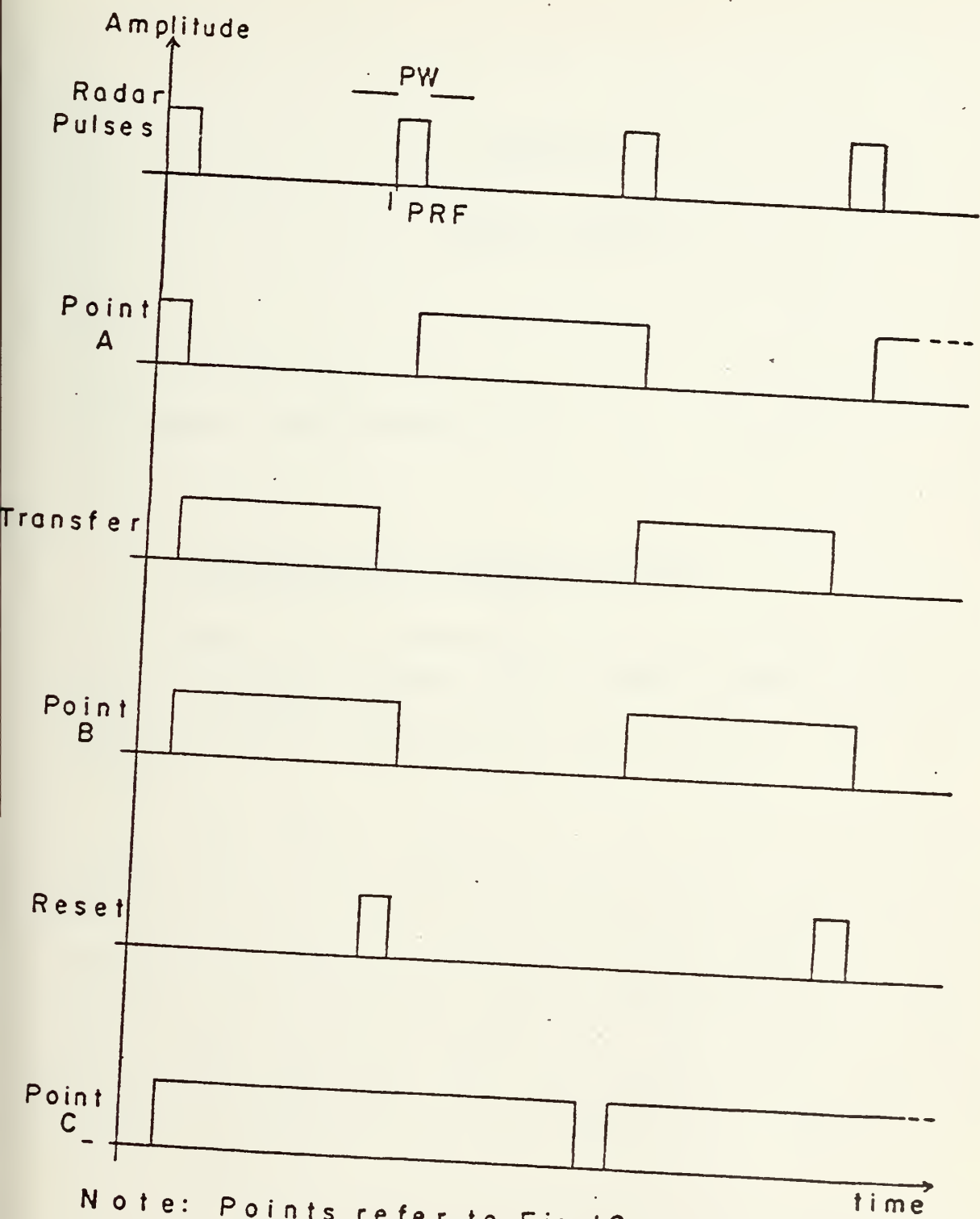

Figure 16 - PW - LOGIC CONTROL





Note: Points refer to Fig. 16

Figure 17.- PW - TIMING WAVEFORMS



## APPENDIX B

### MODERN MISSILES

#### A. GENERAL CLASSIFICATION [39]

##### 1. Surface-to-Air Shipborne Missiles

\* ASPIDE 1-A, developed by Selenia, Italy, to be used with the Albatros system [40]. This system, which has already been delivered to the Italian and two other navies, at present uses the AIM-7E Sparrow 3 missile.

The forward section of the Aspide contains the guidance unit, which consists essentially of the auto-pilot, the radar receiver, and its self-aligning antenna. The radar receiver, a monopulse, fast tuning in the I-band (8-10 Ghz), processes the illuminator signals reflected from the target, and computes the error relative to the collision course. These error data are fed to the auto-pilot, which then transmits the necessary course correction signal to the control surfaces.

It can also be used as an air-to-air missile with very good capability in the following areas - ECCM and fixed echo suppression, short range performance, effectiveness at high altitude and unit cost. It will be the main armament of the Italian Air Force's F-104 interceptors.



\* MASURCA MK II, developed by Ecan Ruelle, France, to equip the guided missiles French frigates Colbert, Suffren and Duquesne. Supersonic targets can be intercepted at ranges of up to 20 miles. The missile, which carries a proximity-fused high explosive warhead, has two versions:

- Mod 2 with a beam-rider guidance system
- Mod 3 with a semi-active homing system.

\* CRCTAIE, developed by Thomson-CSF, France, and selected by the French Navy to defend its fleet of helicopter-carriers, frigates and corvettes against supersonic air attacks. It is an all weather, low-altitude weapon system.

\* SEA IART, manufactured by Hawker Siddeley, England, has been fitted in Royal Navy and also on two type 42 Argentinian destroyers. It employs semi-active radar homing using the Tracker Illuminator Radar type 909. It has high and low altitude capability against aircraft and missiles and can be used in the surface-to-surface role. The radar type 909 probably has a C-band operating frequency range and elaborate ECCM are incorporated to counter both active and passive ECM. Range is 20 miles.

\* SEACAT, manufactured by Short Bros and Harland, England, and standard armament aboard the following navies: English, Brazilian, Argentinian, Federal German, Chilean, and several others. Therefore, a number of different fire control systems are in use, the more modern being a closed circuit TV system. It has a short range of about two miles.

\* STANDARD RIM-66A/67A, manufactured by General Dynamics, USA, in two versions, one to replace Tartar and the other to replace Terrier. Both versions have all-electric controls, solid-state electronics, an adaptive auto-pilot and a semi-active homing system. The model 66A has a range of about 10 miles, while model 67A, due to its





two-stage powerplant, has a range of 30 miles.

\* SEAWCIF, developed by British Aircraft Corporation and advertised as the most precise weapon against missiles. According to its description it will also provide vessels with powerful self-defense against several types of aircraft. Acquisition radars are Marconi 967 and 968, tracking radar Marconi 910 and missile TV tracking by a Marconi-Ellicott system.

\* GCFLET, or SA-N-3, a Russian missile developed to equip the helicopter-carrier Moskwa and the Kresta-II class cruisers. Its range is about 20 miles but other data is not available in the unclassified literature.

\* SA-N-4, a missile also in service on the Russian Navy aboard its Nanuchka class corvettes and destroyers of the Krivak class. It is an all-weather missile for defense against low-level attack from the air.

## 2. Surface-to-Surface Shipborne Missiles

\* EXOCET, model MM 38, manufactured by Aerospatiale, France, and designed to provide warships with all-weather attack capability against other surface vessels. The missile flight profile consists of a pre-guidance phase set up in the missile circuits before launch and a final guidance phase during which the missile flies directly towards the target under the control of its active homing head. Throughout the flight the missile is maintained at very low altitude by a FM radio altimeter. It has a high subsonic cruising speed and a range of about 20 miles. The French, British, German, Greek, Brazilian, Argentinian and other navies have ordered this missile. Also available now is the model AM 39, fired from a helicopter.

\* OTCMAT, manufactured by a consortium Engins Matra,



France and CTC Melara, Italy, and ordered by the Italian and Venezuelan navies. Subsequent to launching it follows a cruise phase toward the target's predicted position, flying at low level under radio altimeter control and inertial guidance. An active homing head is used for the terminal phase. Its range is about 30 miles being a sea-skimmer for the last two miles. Otomat can also be used as an air-to-surface missile.

\* GAERIEI I, manufactured by Israel Aircraft Industries and operated by the Israeli Navy mounted in the class Saar fast attack craft-missile. During the mid part of its trajectory, the missile has probably radar control from ship in the horizontal plane while its height is maintained by a radio altimeter. Terminal guidance is supposed to be passive homing. Gabriel I is a sea-skimmer with speed mach 0.7 and range 14 miles.

\* PENGUIN, developed by Kongsberg Vaaspenfabrikk, Norway, and fitted in Norwegian frigates and fast attack craft. It has an inertial guidance system with passive infrared terminal homing.

\* HARPOON [41], an all-weather anti-ship missile with range of 60 miles developed by McDonnell Douglas, USA, capable of being launched from aircraft, surface ships and submarines. Midcourse guidance consists of a attitude reference platform and a digital computer. In the terminal phase active radar guidance takes over with a frequency-agile radar varying the operating frequency randomly over a wide bandwidth. Cruise altitude is at low level, controlled by a radar altimeter. Harpoon has a high subsonic cruise speed and the terminal flight profile is pop-up or sea-skimmer.

\* SEA KILLER MK II, a sea-skimmer missile developed by Sistel, Italy, with guidance type beam-rider/radio command/radar altimeter systems. A helicopter-to-ship



version known as the MARTE system is presently under a pre-production development contract.

\* STYX, the Russian missile used in Warsaw Pact forces and also by several other navies, Cuban, Chinese, Indian, Syrian. This missile may be programmed for shorter ranges and has an active radar or infrared terminal homing capability.

\* SHADDUCK, one of the largest of the Russian cruise missiles. Command guidance is used and the missile is tracked by Scoop Pair radar and course corrections transmitted to it by radio. For the terminal phase it is believed that infrared homing is used. Missile speed is transonic and range is limited mainly by radar horizons.

■ several other surface-to-surface missiles are believed to be in use by the Russians, all improved versions of the two described above. A list and partial description of these and other Russian missiles was recently published in an EW magazine [42].

### 3. Air-to-Surface Missiles

\* MARTEL AS 37 from a consortium Engins Matra, France and Hawker Siddeley, England, in two forms: a passive radar homing missile or a television guided missile operated by a weapon operator aboard the parent aircraft. Martel is operational with the Fleet Air Arm and RAF on Buccaneer aircraft and the French services on Mirage III-E, Jaguar and Atlantic aircraft.

\* KORMOBAN, developed by Messerschmitt-Bolkow-Elohm, Germany, and just beginning quantity production. Kormoran is an all-weather weapon which features an autonomous, inertial navigation system in the cruising phase and an active radar search head for target tracking in the final approach flight.



\* AS-11 (E1), from Aerospatiale, France, carried by 14 different types of aircraft (fixed and rotary wing) of 19 nations including all ASW aircrafts of NATO countries. The guidance is visual/manual, with a gyrostabilized optical sighting system, through wires from the control. It is being replaced by the AS-12, being prepared for automatic guidance.

\* SEA SKUA, model CL 834, manufactured by Short Bros and Harland, England, for use from helicopters. Guidance with radar/radio control terminal homing.

\* CCNDCF, model AGM-53A, developed by Rockwell International, USA, a supersonic cruise missile with range of 45 miles and intended for use on carrier-borne aircraft, particularly the A-6. Condor, presently at a pre-production phase, has a conventional warhead and its guidance is by radio control/TV homing.

\* SHRIKE, model AGM-45A, developed by Naval Weapons Center, USA, with a range of seven miles and a speed mach 2. Passive radar homing.

\* STANDARD ARM, model AGM-78A, manufactured by General Dynamics, USA, a passive radar homing missile for the destruction of surface-to-air missile battery radars.

\* KELT, a Russian missile with active radar homing. A more modern missile is the Kerry but there is no unclassified data available. At least a greater speed (mach 3) and an increased range are expected.

#### 4. Air-to-Air Missiles

\* PHOENIX XAIM-7E, developed by Hughes, USA, and specified for the US Navy's F-14 aircraft. The missile is radar-guided, capable of all-weather operation and with





particular application to long-range targets.

\* SPARRCW AIM-7E, by Raytheon, USA, in service with several aircraft of the US Navy and Air Force. It is also used in the Italian interceptors F-104 until it is replaced by the Aspide, probably in 1977. Homing is by means of a Raytheon continuous-wave semi-active homing system. An advanced version, designated AIM-7F is in full-scale production and will be delivered this year.

\* SIDEWINDER, manufactured by Aeronutronic Ford Corporation, USA, in several versions. Accent in Sidewinder is on simplicity and so it is exported to more than twenty nations. Some versions use semi-active radar guidance and others are equipped with infrared homing guidance.

\* MAGIC, developed by Engins Matra, France, with infrared guidance, or another model with semi-active X-band radar homing. This missile arms French Mirage interceptors.

\* RED TCP, by Hawker-Siddeley, England, an infrared weapon for use against sub and supersonic aircraft. All-altitude operation is possible against maneuvering targets and an all-aspect attack capability is provided by the Red Tcp locking and guidance system.

\* BRAZO, designed to intercept an enemy aircraft by homing on its fire control radar emissions. The missile is under development by Hughes, USA, and employs a broadband receiver thought to be optimized for use against the J-band fire control radar of the Foxbat A interceptor version of the Soviet MiG-25.

\* ASE, carried by the Russian long range interceptor Tupolev Tu-28P Fiddler. The Ash (AA-5) is equipped either with a passive infrared homing head or with a semi-active radar guidance head.

\* ACRID (AA-6), a Russian missile used with the MiG-25



Foxtat A high altitude interceptor. Maximum missile speed above 2.5 mach. Like the ASH there are also two versions, semi-active radar homing and IR homing with ranges 45 km and 20 km.



## LIST OF FIGURES

1.	False-target generation.....	32
2.	Search-Lock-Jam-Transponder.....	36
3.	RGPC - Frequency-Memory-Loop.....	40
4.	RGPC - Loopless-Memory-Loop.....	42
5.	IFM discriminator.....	63
6.	IFM polar display.....	65
7.	Scanning Superheterodyne Receiver.....	67
8.	Slow Scan - Intermediate Scan.....	68
9.	Rapid Scan - Microscan.....	70
10.	Channelized Receiving System.....	73
11.	Bragg acousto-optical processing.....	79
12.	PRF - basic circuit.....	120
13.	Decade Counting Assemblies.....	121
14.	PRF - logic control.....	124
15.	PRF - timing waveforms.....	125
16.	PW - logic control.....	127
17.	PW - timing waveforms.....	128



## LIST OF REFERENCES

1. Eustace, Harry F., " The Warsaw Pact's threat to NATO", Electronic Warfare, v. 5 # 1, p. 21, February 1973.
2. Vakin, S. A. and Shustov, L. N., machine translated to English, Electromagnetic Reconnaissance and Jamming, p. 1, National Technical Information Service (NTIS) reference number AD 692642/3, 1969.
3. "Navy Faces Grave Cruise Missile Threat", Aviation Week Space Technology, v. 102 # 4, p. 102, January 27th 1975.
4. Carrcll, John M., Secrets of Electronic Espionage, p. 93, E.F. Dutton, 1966.
5. Skclnik, Merril I., Introduction to Radar Systems, p. 538, McGraw-Hill Book Company, 1962.
6. Skclnik, Merril I., Radar Handbook, p. 5-29, McGraw-Hill, Inc., 1970.
7. Boyd, A. J. et al., Electronic Countermeasures, p. 15-1 to 15-18, Institute of Science and Technology of the University of Michigan, 1961.
8. Fitts, Richard E., The Strategy of Electromagnetic Conflict, p. 92, United States Air Force Academy, 1975.
9. Day, Ronald G., " Deception Repeaters Jam Hostile Radars", Microwaves, v. 9 # 12, p. 36, December 1970.





10. Flaherty, James M., " ECM Chessboard", Electronic Warfare, v. 5 # 2, p. 37, April 1973.
11. "Frequency Memory Loop", Electronic Warfare, v. 6 # 5, p. 67, September/October 1974.
12. Specter, Sheldon C., " A Coherent Microwave Memory Using Digital Storage: "The Loopless Memory Loop"", Electronic Warfare, v. 7 # 1, p. 108, January/February 1975.
13. Vakin, S. A. and Shustov, L. N., machine translated to English, Electromagnetic Reconnaissance and Jamming, p. 177, National Technical Information Service (NTIS) reference number AD 692642/3, 1969.
14. Schniger, Kenneth R. and Eustace, Harry F., The International Countermeasures Handbook, p. 390, EW Communications, Inc., 1975.
15. Skolnik, Merrill I., Radar Handbook, p. 20-4, McGraw-Hill, Inc., 1970.
16. Fitts, Richard E., The Strategy of Electromagnetic Conflict, p. 73, United States Air Force Academy, 1975.
17. Technical Leaflet "An Introduction to Instantaneous Frequency Measuring (IFM) Receivers" from ARGOSystems Inc., Palo Alto, California, USA.
18. Eoyd, A. J. et al., Electronic Countermeasures, p. 6-22 to 6-32, Institute of Science and Technology of the University of Michigan, 1961.
19. Hewitt, Harry S., The Microscan Signal Intercept and Analysis System, p. 1 - 13, Stanford Research Institute, 1971.
20. "The Channelized Receiving System", Microwave Systems



- News - MSN, v. 5 # 6, p. 63, January 1976.
21. Alliscr, Andrew A., " Computers in Electronic Warfare", Electronic Warfare, v. 5 # 5, p. 81, September 1973.
  22. Adler, Robert, " Interaction between Light and Sound", IEEE Spectrum, v. 4 # 5, p. 43, May 1967.
  23. "US Strives to Cope with Growing Threats", Aviation Week Space Technology, v. 102 # 4, p. 41, January 27th 1975.
  24. "Typical Airborne EW Equipment", International Defense Review, v. 9 # 1, p. 64, February 1976.
  25. White, C. E., " Surveillance Receivers Today and Tomorrow", Microwave Journal, v. 19 # 1, p. 40, January 1976.
  26. "New Low Cost Receivers Introduced", Electronic Warfare, v. 6 # 4, p. 64, July/August 1974.
  27. Harper, Terry, " Rotary DF antennas", Electronic, Electro-Optic and Infrared Countermeasures, v. 1 # 1, p. 55, March 1975.
  28. Fitts, Richard E., The Strategy of Electromagnetic Conflict, p. 218 to 237, United States Air Force Academy, 1975.
  29. Corse, C. D. , Introduction to Shipboard Weapons, p. 305 to 318, Naval Institute Press, 1975.
  30. Dax, Peter R., " Keep Track of That Low-Flying Attack", Microwaves, v. 15 # 4, p. 36, April 1976.
  31. Dave Fitzpatrick, " Infrared Comes of Age in the World of Electronic Warfare", Electronic Warfare, v. 7 # 6, p. 38, November/December 1975.
  32. "Planners Seek Effective Visual Defense", Aviation



- Week Space Technology, v. 102 # 4, p. 88, January 27th 1975.
33. Hudson, Richard D. and Hudson, Jacqueline W., " Laser, Low Light Level Television and Forward Looking Infrared Systems", AGARD Lecture Series, v. 76, p. 1-1 to 3-1, 1975.
34. Bulletin # 111, The Kuras-Alterman Corporation, New Jersey, USA.
35. Harry F. Eustace, " Crows vs. Gunners - Navy EW Crisis", Vector - Microwave Systems News, v. 1 # 4, p. 5, Aug/Sep 1972.
36. "Shipboard ECM : Threat Reaction", Microwave Systems News, v. 2 # 7, p. 34, September/October 1971.
37. "The 1975 Royal Navy Equipment Exhibition", International Defense Review, v. 8 # 6, p. 843, December 1975.
38. "The French Naval Exhibition", International Defense Review, v. 8 # 1, p. 103, February 1975.
39. Pretty, Ronald T., Jane's Weapon Systems 1976, p. 51 - 162, Jane's Yearbooks, England or Franklin Watts, Inc., USA, 1976.
40. Meller, R., " Air Defense with the Aspid 1-A", International Defense Review, v. 8 # 2, p. 215, April 1975.
41. Pretty, Ronald T., " New Challenges for the EW Community", Electronic Warfare, v. 8 # 2, p. 45 - 65, March/April 1976.
42. Meller, R., " The Harpoon Missile System", International Defense Review, v. 8 # 1, p. 61, February 1975.



INITIAL DISTRIBUTION LIST

	No. Copies
1. Defense Documentation Center Cameron Station Alexandria, Virginia 22314	2
2. Library, Code 0212 Naval Postgraduate School Monterey, California 93940	2
3. Department Chairman, Code 52 Department of Electrical Engineering Naval Postgraduate School Monterey, California 93940	2
4. Associate Professor Donald A. Stentz, Code 52Sz Department of Electrical Engineering Naval Postgraduate School Monterey, California 93940	1
5. Associate Professor John M. Bouldry, Code 52Bo Department of Electrical Engineering Naval Postgraduate School Monterey, California 93940	1
6. CC Raul Pereira Bittencourt Diretoria de Comunicacoes e Eletronica da Marinha Ilha das Cobras - Ministerio da Marinha Rio de Janeiro 20000 Brazil	2
7. Commander P. S. Roder, USN Curricular Officer for Electronics and	1





Communications Programs, Code 32  
Naval Postgraduate School  
Monterey, California 93940



Thesis  
B54527  
c.1

Bittencourt  
Electronic warfare  
technology.

165820

12 JUL 78  
15 SEP 78  
5 DEC 78  
10 AUG 79  
30 AUG 88

NOV 15 '78

25018  
24661  
25071  
S12294  
32449

9

Thesis  
B54527  
c.1

Bittencourt  
Electronic warfare  
technology.

165820

thesB54527

Electronic warfare technology.



3 2768 001 03663 5

DUDLEY KNOX LIBRARY